



**Family of Circulators**

Taco LoadMatch® series circulators are designed for quiet, efficient operation on LoadMatch fan coil heating & cooling systems. Each circulator includes a removable Integral Flow Check (IFC®) to prevent gravity flow and reduce installation costs. An anti-condensate baffle prevents the build up of condensate on the motor windings when pumping chilled water. The unique, field serviceable cartridge contains all moving parts. Replacing the cartridge rebuilds the circulator. With no mechanical seal, the self-lubricating, maintenance-free design provides unmatched reliability.



Taco LoadMatch®. Real world hydronic system technology for Green Building design.



### Unmatched reliability and quiet, efficient operation:

Taco's LoadMatch® circulators move water in the direction it needs to go in closed loop, single pipe systems of LoadMatch design. LoadMatch circulators reduce operating and maintenance costs by providing a lower pump head and less horsepower to match separate loads in zoned applications. With individual LoadMatch circulators in place for each zone in a building, and all loads operating separately from each other, water through the direct return LoadMatch system behaves exactly the way it was intended. LoadMatch circulators, in fourteen

models of bronze or cast iron construction, provide unmatched reliability and maintenance free operation. Each LoadMatch circulator comes with an integral flow check (IFC®) to prevent gravity flow and an exclusive anti-condensate baffle to protect motor windings against condensate build-up in chilled water systems.

Known for their quiet, efficient operation, compact LoadMatch circulators are self-lubricating and have no mechanical seal. The unique, field serviceable cartridge contains all

moving parts, allowing for easy service instead of replacing the entire circulator.

Connecting terminal unit secondary piping circuits to their primary piping



circuits in a two pipe LoadMatch system is accomplished through the use of Taco Twin Tee® fittings.

LoadMatch circulators also feature optional variable speed and priority zoning models.

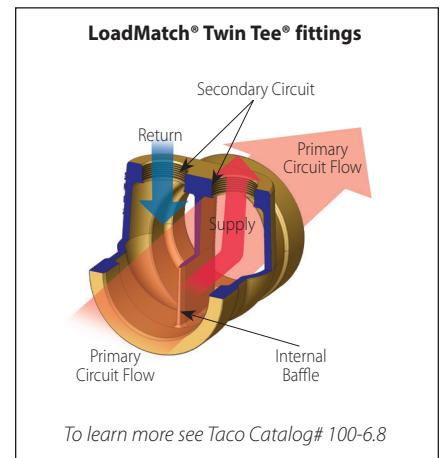
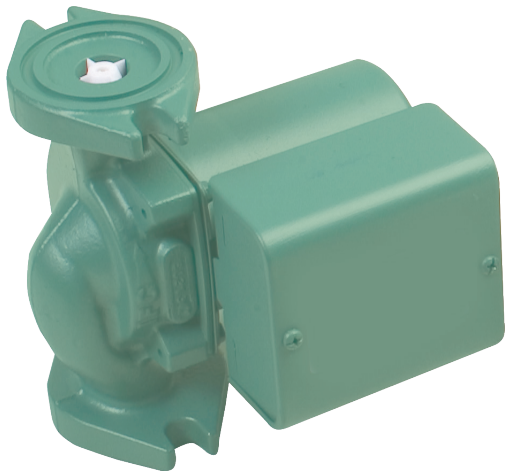

### **Integral Flow Check (IFC®) Prevents Ghost Flows**

An integral spring loaded flow check prevents any “ghost flows” or unwanted flows in the terminal unit secondary circuit when the circulator is off.



The flow check prevents unwanted flow. The spring provides approximately

10” w.c. pressure

drop in direction of flow to prevent unwanted or ghost flows when the LoadMatch® circulator is off.

Ghost flows can develop in the terminal unit secondary circuit when the two tees to the secondary circuit are not installed correctly. These tees should be installed as close together

as possible. If they aren’t then the path of least resistance for some of the water is through the secondary circuit and terminal unit.

This can result in overheating or overcooling when the circulator is cycled off by the room or zone thermostat. The integral spring loaded flow check prevents these ghost flows.

### **Anti-Condensate Baffle Prevents Condensation in the Motor Housing**

An anti-condensate baffle prevents condensation from collecting inside the motor housing and shorting out the motor windings.

If the circulator is used in chilled water applications in humid climates condensation will occur inside the motor

housing. This condition is inherent in any wet rotor circulator, and is a result of direct metallic contact between the motor housing and the volute containing cold chilled water.

The anti-condensate baffle provides an air gap between these two components effectively insulating the motor housing from the cold volute.

### **Standard Pressure Rating is 200 PSI**

The standard pressure rating of a LoadMatch circulator is 200 psi.

This enables the circulator to be used in medium and high rise construction without having to install hydraulically isolated subsystems.

It can also be used in integrated piping systems utilizing fire protection piping to meet NFPA Chapter 13 pressure ratings of 175 psi.



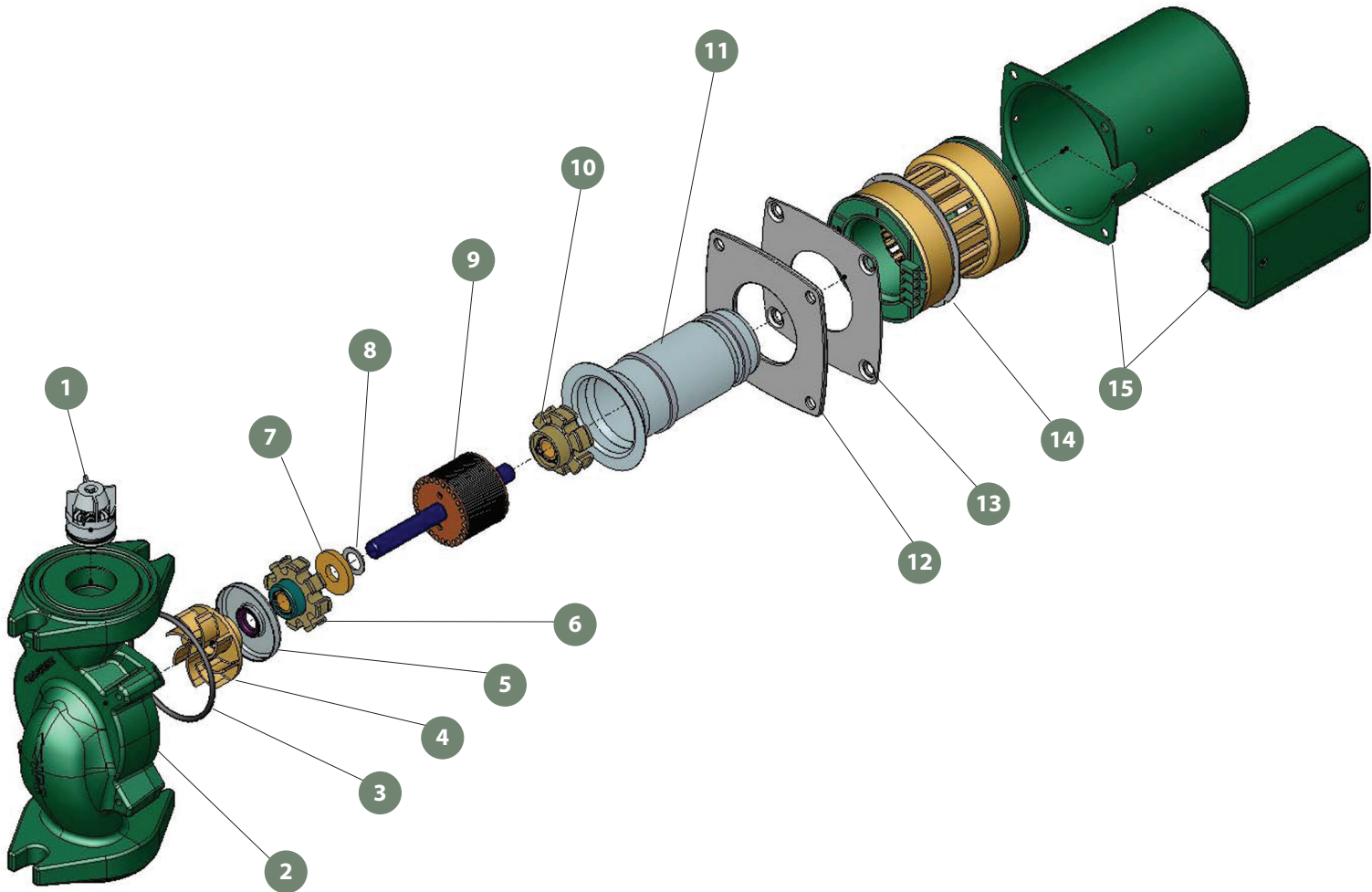

(#1) **Integral Flow Check (IFC)** — prevents gravity flow.

(#2) **Casing** — Cast iron or Bronze.

(#3) **Casing O-ring** — EPDM

(#4) **Impeller** — Polypropylene 30% glass filled

(#5) **Dirt Barrier** — Keeps system dirt away from bearings.

(#6) **Front Bearing Support Assembly** — Brass with carbon bearings for smooth operation and long life.

(#7) **Thrust Washer** — Prevents noise and wear on rotor / front bearing.

(#8) **Spacer Washer.**

(#9) **Rotor / Shaft** — Steel rotor, hollow ceramic impeller shaft.

(#10) **Rear Bearing Support Assembly.**

(#11) **Cartridge Sleeve** — Stainless Steel.

(#12) **Cartridge Support Plate** — Seals cartridge and casing O-ring.

(#13) **Anti-Condensate Baffle** — Allows for ambient air flow, prevents build-up of condensate on motor.

(#14) **Stator** — Permanent split capacitor.

(#15) **Motor Housing/Capacitor Box Assembly**



### Part I — Fundamentals

A centrifugal pump operated at constant speed delivers any capacity from zero to maximum depending on the head, design and suction conditions. Pump performance is most commonly shown by means of plotted curves which are graphical representations of a pump's performance characteristics.

Pump curves present the average results obtained from testing several pumps of the same design under standardized test conditions. For a single family residential application, considerations other than flow and head are of relatively little economic or functional importance, since the total load is small and the equipment used is relatively standardized. For many smaller circulators, only the flow and pressure produced are represented on the performance curve (Fig. 1-1).

For larger and more complex buildings and systems, economic and functional considerations are more critical, and performance curves must relate the hydraulic efficiency, the

power required, the shaft speed, and the net positive suction head required in addition to the flow and pressure produced (Fig. 1-2).

Pump performance curves show this interrela-

charts normally give flow, head and pump size only, and the specific performance curve must then be referred to for impeller diameter, efficiency, and other details. For most applications in our industry, pump curves are based on clear water with a specific gravity of 1.0.

### Part II – The System Curve

Understanding a system curve, sometimes called a system head curve, is important because conditions in larger, more complex piping systems vary as a result of either controllable or uncontrollable changes. A pump can operate at any point of rating on its performance curve, depending on the actual total head of a particular system. Partially closing a valve in the pump discharge or changing the size or length of pipes are changes in system conditions that will alter the shape of a system curve and, in turn, affect pump flow. Each pump model has a definite capacity curve for a given impeller diameter and speed. Developing a system curve provides the means to determine at what point on that curve a pump will operate when used in a particular piping system.

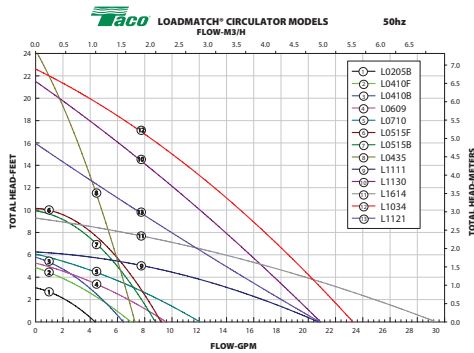

Fig 1-1\*

tion of pump head, flow and efficiency for a specific impeller diameter and casing size. Since impellers of more than one diameter can usually be fitted in a given pump casing, pump curves show the performance of a given pump with impellers of various diameters. Often, a complete line of pumps of one design is available and a plot called a composite or quick selection curve can be used, to give a complete picture of the available head and flow for a given pump line (Fig. 1-3). Such

\*See Page 16 for Larger 50Hz & 60Hz Performance Curves

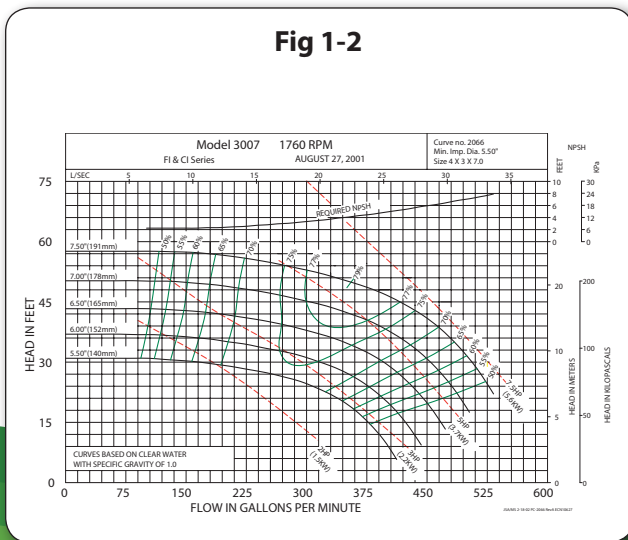

Fig 1-2

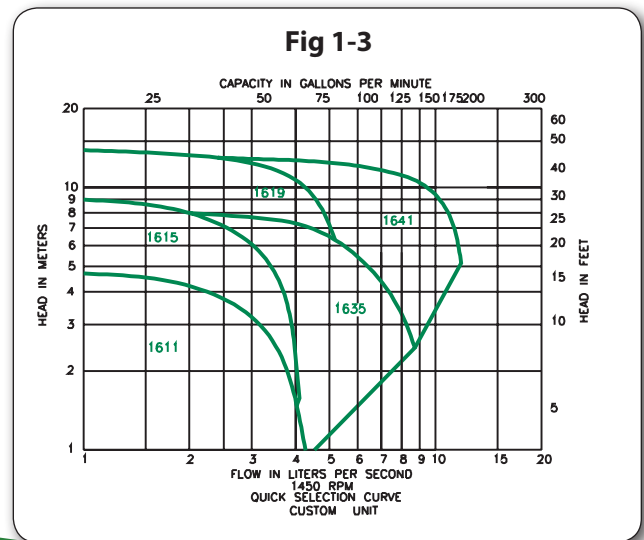

Fig 1-3

Pipes, valves and fittings create resistance to flow or friction head. Developing the data to plot a system curve for a closed Hydronic system under pressure requires calculation of the total of these friction head losses. Friction tables are readily available that provide friction loss data for pipe, valves and fittings. These tables usually express the losses in terms of the equivalent length of straight pipe of the same size as the valve or fitting. Once the total system friction is determined, a plot can be made because this friction varies roughly as the square of the liquid flow in the system. This plot

represents the SYSTEM CURVE. By laying the system curve over the pump performance curve, the pump flow can be determined (Fig. 2-1).

Care must be taken that both pump head and friction are expressed in feet and that both are plotted on the same graph. The system curve will intersect the pump performance curve at the flow rate of the pump because this is the point at which the pump head is equal to the required system head for the same flow.

Fig. 2-2 illustrates the use of a discharge valve to change the system head to

vary pump flow. Partially closing the valve shifts the operating point to a higher head or lower flow capacity. Opening the valve has the opposite effect. Working the system curve against the pump performance curve for different total resistance possibilities provides the system designer important information with which to make pump and motor selection decisions for each system. A system curve is also an effective tool in analyzing system performance problems and choosing appropriate corrective action.

In an open Hydronic system, it may be necessary to add head to raise the liquid from a lower level to a higher level. Called static or elevation head, this amount is added to the friction head to determine the total system head curve. Fig. 2-3 illustrates a system curve developed by adding static head to the friction head resistance.

**Fig 2-1**

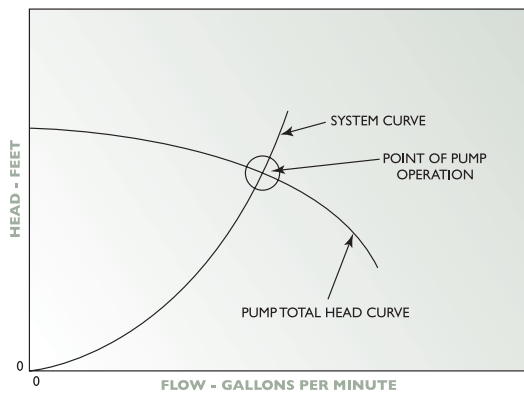

**Fig 2-2**

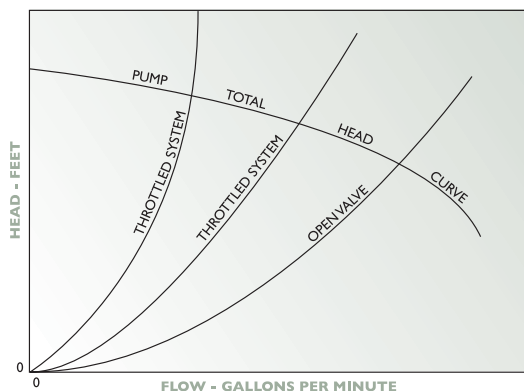

**Fig 2-3**

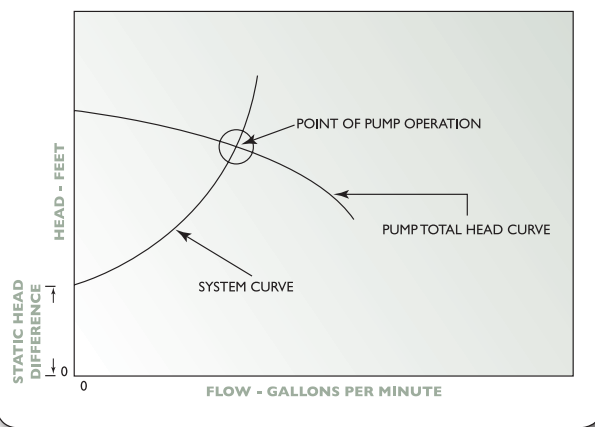

### Part III The LoadMatch Concept

A LoadMatch system is the marriage of two old ideas wrapped around a new technology. The old ideas are *single pipe distribution* and *primary-secondary pumping*. The new technology consists of the use of maintenance-free wet rotor circulators. A primary distribution system is a single pipe loop; the secondary distribution system is a decoupled secondary piping loop for each terminal unit in the system.

The wet rotor circulator provides the specified flow to each terminal unit at all times. The simplicity of the LoadMatch concept allows you to specify one size of pipe for large portions of the system. In single loop installations, there is no limit to the number of fan coils you can install. Final pipe size is determined by the total load of the loop and  $\Delta T$ . If your loop is heavily loaded, it's practical to split the system into two loops with smaller pipe sizes. This change saves

installation costs, energy, and money, and can reduce pump head, and lower hp. When loops are carrying equal loads and arranged symmetrically, they will nearly self-balance. The resulting configuration will keep balancing losses down and will lower ongoing energy costs.

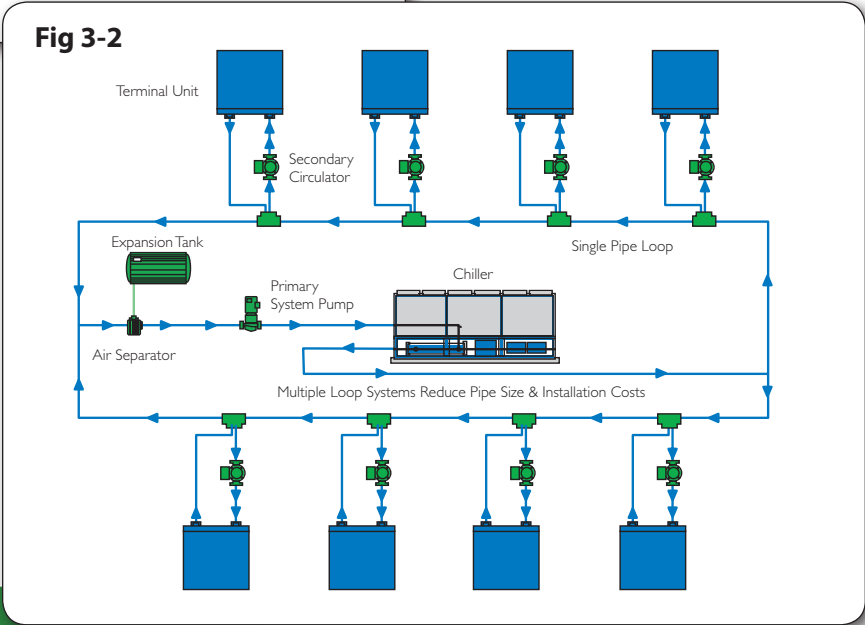
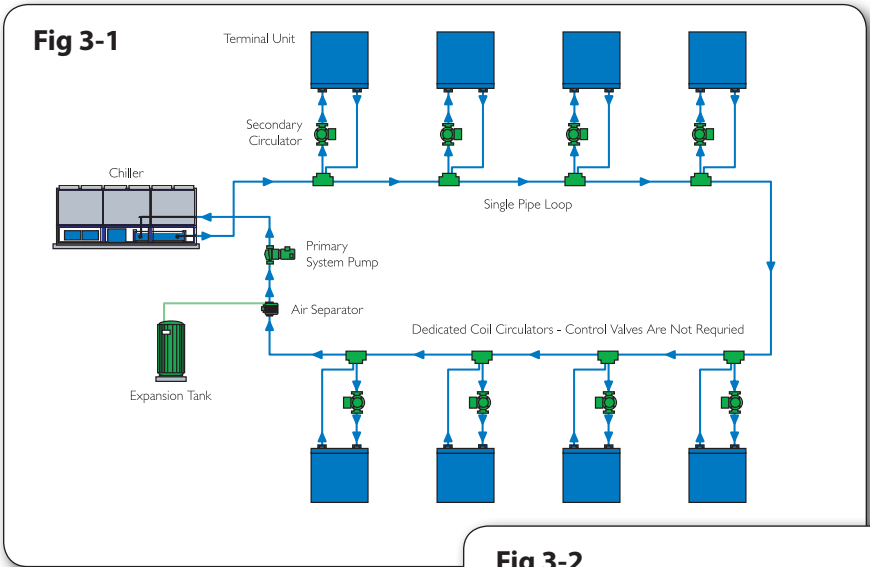

### Cutting Design Time

The simplicity of the Taco LoadMatch system shaves hours of planning off the job. Taco’s powerful new Hydronic System Solutions intelligent CAD software reduces errors, typically saving 30% in total design and construction administration time.

### LoadMatch Building Blocks (See Fig. 3-3)

The run-out piping between the single-pipe loop and the terminal unit follows conventional design practice. When a coil is farther away from the loop, simply extend the run-out length and adjust the circulator for any increase in head.

Boilers, chillers, and terminal units are always sized based upon heat gain and heat loss calculations, and are selected to suit the loads. Unlike reverse return systems, LoadMatch

provides highly efficient BTU transport between the generators and the heating or cooling terminal units.

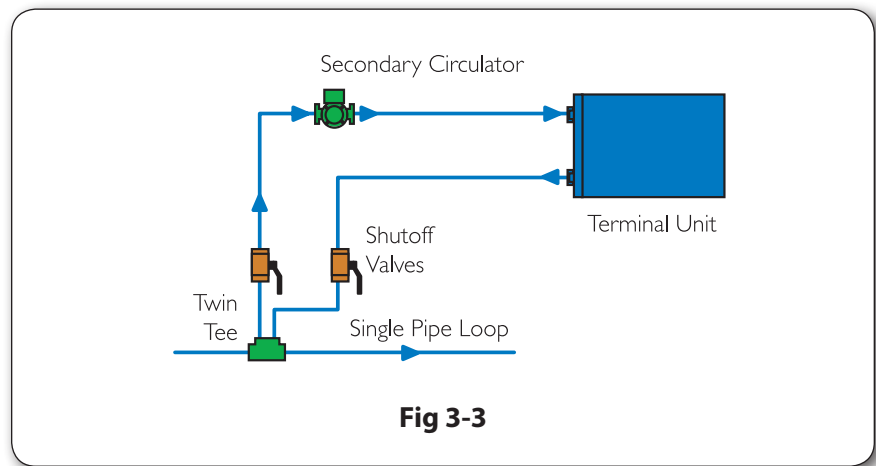



## Managing Temperature

For design engineers the most cited concern about LoadMatch systems that arises is the temperature cascade of the system. Because the water temperature in the loop changes, it would appear that the terminal units at the end of the loop are not going to be able to provide the necessary BTU's for the heating or cooling loads. So they ask, "In a cooling system, how is your system able to provide the same capacity, including dehumidification, at the end of the loop experiencing 50° F entering water when other units at the start of the loop are experiencing 40° F entering water?" This is a legitimate question.

An examination of basic heat transfer fundamentals will provide the answer.

Consider the single dimensional steady state heat transfer form of the Navier-Stokes equation, shown below.

$$\Delta Q = U \times A \times \Delta T$$

Where:

$\Delta Q$  is the heat transfer rate,

$U$  is the heat transfer coefficient,

$A$  is the surface area,

$\Delta T$  is the temperature difference

Let's take a room that we want to maintain at 70° F. If the room is at the beginning of the loop we have a 40° F water supply, so the  $\Delta T$  between the water supply and the room is a 30° F difference (70°F – 40°F). However, at the end of the loop the water is at 50° F, so now the  $\Delta T$  is 20° F (70°F - 50°F). In order to maintain the heat transfer of a terminal unit at constant capacity with a decreased  $\Delta T$ , either the heat transfer coefficient or  $U$  value, or area  $A$ , or a combination of both, has to be increased.

The heat transfer coefficient or  $U$  value in a typical terminal unit is a function of fluid velocity, and the area  $A$  is a function of rows. The answer lies in increasing the flow rate through the heat exchanger or in adding more rows, or a combination of both, in order to compensate for the decreased  $\Delta T$ . Following is an example of applying this simple concept to a typical fan coil unit (See Figure #3-4):

As the above graph shows, the sensible and latent capacity of the terminal unit can be achieved in several ways by varying combinations of increased heat transfer coefficient or  $U$  value (velocity) or area  $A$  (number of rows).

At the beginning of the loop – shown by the point at the left of the graph – at 40°F entering water, utilizing a 2 row coil at 1 gpm, yields a given sensible and latent capacity. At the end of the loop – as shown by the point at the middle of the graph, we can achieve the same sensible and latent capacity (50°F entering water temperature) by increasing the  $U$  value or velocity (50°F entering water temperature, 2 rows and 2.2 gpm). As an alternative – shown by the point at the right of the graph – we can achieve the same capacity by increasing the area or number of rows (50°F entering water temperature, 3 rows, and 1.5 gpm).

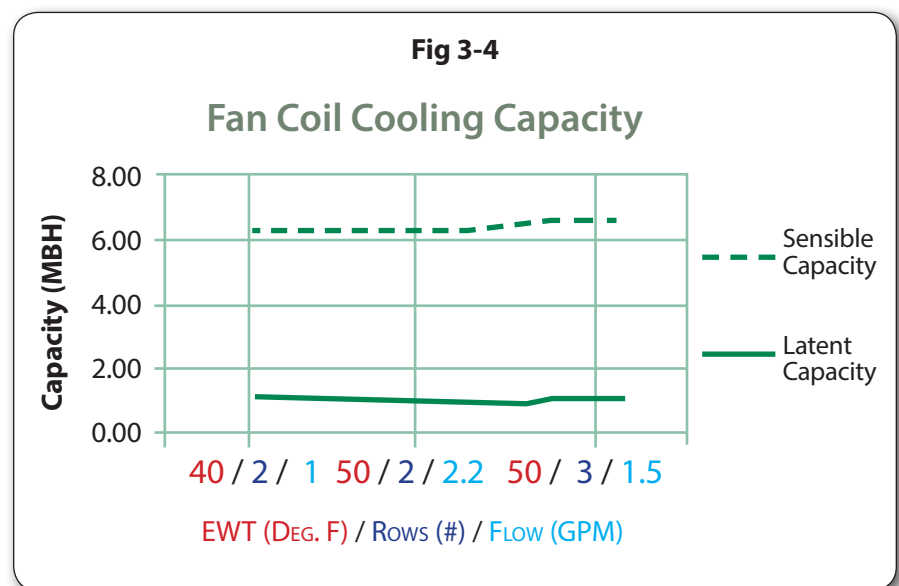

This is possible because the dew point of the airstream on the coil at ASHRAE room Comfort Zone conditions of 75°F and 60% RH has a dew-point of 60°F. Therefore an entering chilled water temperature of 50°F is certainly capable of dehumidifying this air stream.

Despite concerns about the temperature cascade in a LoadMatch cooling system, the use of basic principles of thermodynamics and psychrometrics, as described above, **will result in comfortable room conditions, including dehumidification, in very humid climates.**

Taco's Hydronic System Solutions software is now available that will calculate the temperature cascade automatically and provide a flow diagram printout of the entering water temperature at every terminal unit in the system. Using the flow diagram temperature cascade information, the engineer selects the terminal unit for the correct cascaded entering water temperature at each terminal unit.

Another approach to selecting all the terminal units at different entering water temperatures is to select the terminal units at the same entering water temperature.

A recommendation is to use a worst case entering water temperature, taking into account the diversity of the system. Diversity is typically defined as the actual load divided by the design load. For our 10° F design  $\Delta T$  example, and assuming a 70 percent diversity factor, one can select all the units at 47°F entering water temperature ( $47^{\circ}\text{F} = 40 + 0.7 \times 10$ ). Therefore, using this method, the process to select terminal units for a single pipe system is no different than selecting terminal units for a two pipe system.

A second concern about the temperature cascade that should be addressed here is a common misconception that the use of multiple terminal units on a loop adversely affects the temperature cascade.

Again, an examination of basic heat transfer fundamentals will provide the answer.

Take the steady state mass transfer equation, shown below:

$$\Delta Q = M \times C_p \times \Delta T$$

Where:

$\Delta Q$  is the heat transfer rate

M is the mass transfer rate

$C_p$  is the specific heat

$\Delta T$  is the temperature difference

In any loop the mass flow rate (M) is a function of the total load of all the terminal units, divided by the specific heat and the design  $\Delta T$  for the system. Because the  $\Delta T$ 's are determined by the design, and not by the number of terminal units, the flow will always increase to match the load. Therefore the last terminal unit on a loop will never experience more than the design  $\Delta T$ .

Interestingly, the more terminal units on a loop the better the temperature cascade will be at the last terminal unit. This concept is admittedly counterintuitive, but is the result of the diversity in the system. With more terminal units, there will be more diversity, and a better entering water temperature at the last terminal unit.

### Variable Speed drive

LoadMatch® circulators are available with an optional variable speed drive to satisfy a variety of applications. The drive is integral to the circulator in an all-in-one package.

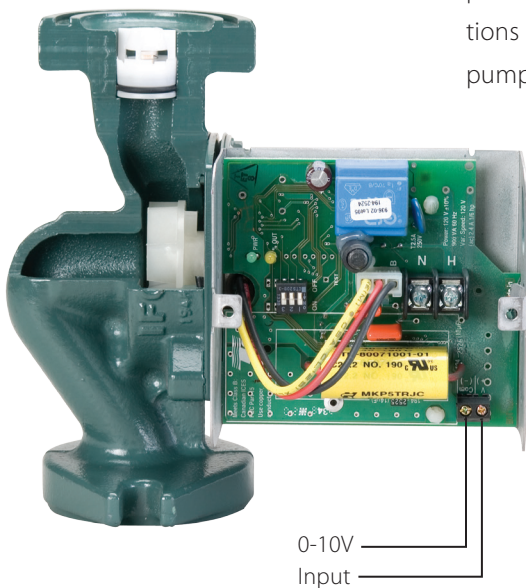

The drive is available in a Variable Speed Setpoint (VS) or Variable Speed Variable Voltage (VV) configuration.

**The Variable Speed Setpoint (VS)** version can be set up to deliver a fixed temperature, maintain a specific temperature drop between sensor locations ( $\Delta T$ ), used as a bypass / shunt pump or integrated into a fan coil

package to vary the speed of the pump based on supply air temperature. The setpoint adjustment is integral to the onboard drive.

VS can be either direct acting (speed increases on a temperature decrease) or reverse acting (speed increases on a temperature increase).

**The Variable Voltage (VV)** version can be set up to operate the circulator at different speeds based on an externally generated analog signal input. Its reliable operation, ease of installation and integration to DDC or Building Management Systems allows for a wide variety of HVAC applications, such as maintaining a room temperature or humidity setpoint. The control accepts a 0-10 V(dc), 0-20 mA, 2-10 V(dc), or 4-20mA signal.

The variable speed drive also saves operating costs. Following is a graph (fig. 3-5) of power consumption vs. speed or flow rate of a typical circulator.

**Fig 3-5**

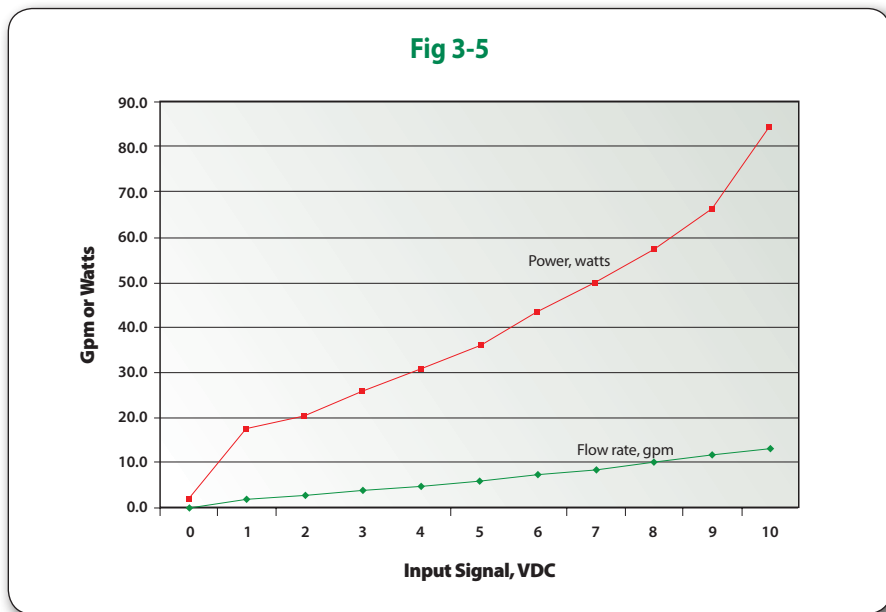

Turndown of the circulator is also excellent. At low speeds the control algorithm changes to a pulse control operating the circulator in pulses of 100% torque or speed and varying the time between pulses.

This eliminates the turndown limitation typical of control valves since the turndown is now a function of the accuracy of the external DDC controller and sensor, not the construction of the circulator (valve).

The turndown of a typical terminal unit control valve is in the range of 30:1. The turndown of a LoadMatch® variable speed circulator is over 100:1.

**Dehumidification with Variable Speed Drive**

The VV drive can be used to provide accurate room humidity control in humid climates through the use of local dehumidification reheat control. To adequately dehumidify in humid

climates humidity must be controlled directly rather than indirectly, whenever an air conditioning unit runs. This is because the sensible heat ratio of a load in a humid climate (0.7 to 0.75) is lower than the sensible heat ratio of a typical cooling coil (0.8 to 0.85).

Therefore, to adequately dehumidify, the air conditioning unit must remain on. However, a typical air conditioning unit is cycled off by sensible heat or dry bulb air temperature in the room thermostat. Therefore indirect humidity control does not provide satisfactory dehumidification in humid climates.

Direct humidity control requires the use of a humidity sensor and humidity controller in the occupied spaces controlling the air conditioning unit's cooling coil to achieve humidity setpoint. The cooling coil's variable speed circulator is therefore controlled from two sources, demand for space cooling or demand for space dehumidification.

Psychrometrically this will result in overcooling of the space to achieve the humidity setpoint. The room or supply air must then be reheated to satisfy the room's temperature setpoint using the heating coil's variable speed circulator.

This can be done with larger 100% dedicated outside air (DOAS) central air handling units and space consuming ductwork, or with no air handling unit or ductwork by smaller room terminal units.

Comfort and energy efficiency are optimized and cost reduced when dehumidification, and the associated reheat, are accomplished with smaller terminal units at the zone or room level, e.g. fan coils. Both central air handling units or room terminal units require a cooling and heating coil with the heating coil in the reheat position as shown in figure 3-6.

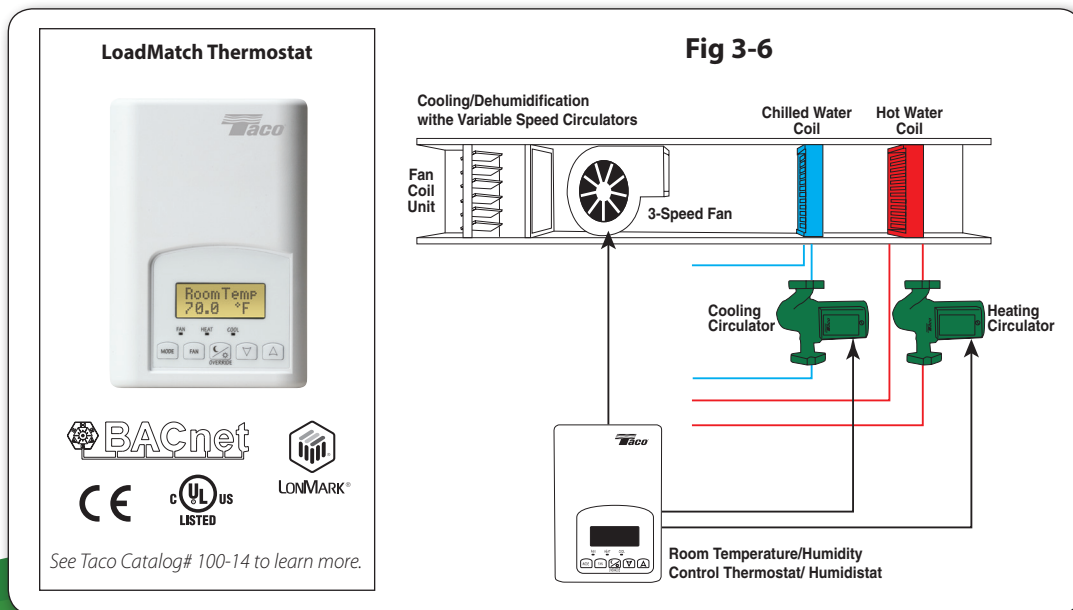

## Selection Example

### Example 1:

#### Problem:

Select LoadMatch® circulators to provide heating and cooling to a fan coil unit.

#### Conditions:

Heating coil requires 5 gpm at 5 ft. head.

Cooling coil requires 10 gpm at 8 ft. head.

The circulators will use flanged connections.

#### Selection Procedure:

1. From the LoadMatch circulator family of curves select a Model L0410F for the heating coil. The F suffix indicates cast iron body with flanged connections.
2. From the LoadMatch circulator family of curves select a Model L1121 for the cooling coil. The L1121 is furnished standard cast iron body with flanged connections.

## Selection Example

### Example 2:

#### Problem:

Select LoadMatch circulators to circulator to provide heating and cooling to a heat pump unit.

#### Conditions:

Condenser coil requires 5 gpm at 10 ft. head. The circulator will use sweat connections.

#### Selection Procedure:

1. From the LoadMatch circulator family of curves select a Model L0515B for the heating coil. The B suffix indicates bronze body with sweat connections.

**Features**

- Integral Flow Check (IFC™)
  - Prevents gravity flow
  - Eliminates separate in-line flow check
  - Reduces installed cost, easy to service
  - Improved performance vs. In-line flow checks
- Exclusive ACB — Anti-Condensate Baffle - protects motor windings against condensate build-up
- Unique replaceable cartridge— Field serviceable
- Unmatched reliability— Maintenance free
- Quiet, efficient operation
- Direct drive-Low power consumption
- Self lubricating, No mechanical seal
- Standard high capacity output— Compact design

**Mounting Positions**

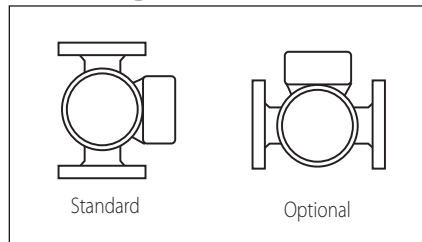

**Flange Orientation**

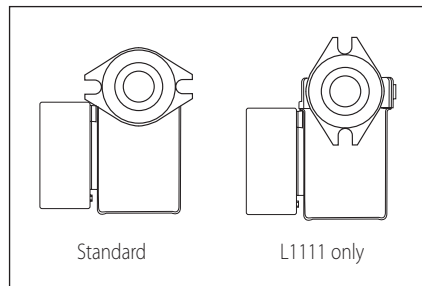

**Materials of Construction**

- Casing (Volute): Cast Iron or Bronze
- Integral Flow Check:
  - Body, Plunger.....Acetal
  - O-ring Seals.....EPDM
  - Spring.....Stainless Steel
- Stator Housing:..... Steel or Aluminum
- Cartridge:..... Stainless Steel
- Impeller:..... Non-Metallic
- Shaft: ..... Ceramic
- Bearings:..... Carbon
- O-Ring & Gaskets: EPDM

**Performance Data**

Minimum Fluid Temperature: 32°F (0°C)

Maximum Fluid Temperature: 230°F (110°C) Cast Iron  
220°F (104°C) Bronze

Maximum Working Pressure: 200 psi

Connection Sizes:  
3/4", 1", 1-1/4", 1-1/2" Flanged  
1/2", 3/4" Sweat

Electrical Data		3250RPM, 60Hz, Single Phase			2750RPM, 50Hz, Single Phase	
		115V, Amps	208-230V, Amps	277V, Amps	100/110V, Amps	220V, Amps
BRONZE						
L0410	1/40	0.55	0.37	0.19	0.55	0.46
L0515	1/25	0.84	0.51	0.33	0.85	0.52
CAST IRON						
L0410	1/40	0.52	0.36	0.22	0.50	0.39
L0609	1/35	0.52	0.42	0.21	0.52	0.42
L0710	1/25	0.71	0.42	0.29	0.71	0.50
L0515	1/25	0.79	0.46	0.31	0.79	0.50
L0435	1/8	1.40	0.70	0.57	1.60	0.72
L1111	1/8	1.10	0.55	0.50	1.60	0.77
L1130	1/8	1.90	0.90	0.79	1.76	0.80
L1614	1/8	1.57	0.70	0.63	1.70	0.75
L1034	1/6	2.00	1.00	0.90	2.00	1.00
L1121	1/8	1.45	0.73	0.64	1.80	0.82



### Circulator Dimensions & Weights

Model	Connection	A		B		C		D		E		F		Ship Wt.	
		in.	mm	in.	mm	in.	mm	in.	mm	in.	mm	in.	mm	lbs.	Kg
BRONZE															
L0410	1/2", 3/4" swt.	6	152	4-7/8	124	2-3/16	56	2-15/16	75	3-5/16	84	4-3/8	111	6	2.7
L0515	3/4" swt.	6-1/2	165	4-9/16	116	3-3/16	81	2-15/16	75	4-11/16	119	6-3/8	162	9	4.0
CAST IRON															
L0410	Flanged	6-1/4	159	4-3/8	111	3-3/16	81	2-15/16	75	5	127	6-3/8	162	7	3.2
L0609	Flanged	5-5/8	143	4	102	3-3/16	81	2-15/16	75	5	127	6-3/8	162	8	3.6
L0710	Flanged	5-7/8	149	4-1/2	114	3-3/16	81	2-15/16	75	5	127	6-3/8	162	8	3.6
L0515	Flanged	5-15/16	151	4-1/2	114	3-3/16	81	2-15/16	75	5	127	6-3/8	162	9	4.0
L0435	Flanged	7	178	5-11/16	144	3-3/16	81	3-3/8	86	5-1/2	140	6-3/8	162	9.5	4.3
L1111	Flanged	7-1/4	184	5-5/16	135	3-3/16	81	3-5/16	84	5-3/8	137	6-3/8	162	10	4.5
L1130	Flanged	7-1/2	191	6-1/8	156	3	76	3-5/16	84	5-1/2	140	6-1/2	165	12	5.5
L1614	Flanged	8-1/16	205	6-3/8	162	4-1/4	108	3-5/16	84	6	152	8-1/2	216	14	6.3
L1034	Flanged	7-1/2	191	6-3/8	162	3	76	3-7/8	98	6	152	6-1/2	165	12.5	5.7
L1121	Flanged	7-1/4	184	5-3/4	146	3-1/4	83	3-5/16	84	5-1/2	140	6-1/2	165	13	5.9

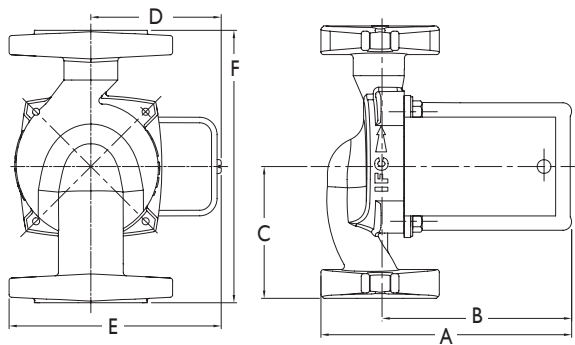

Flanged Models

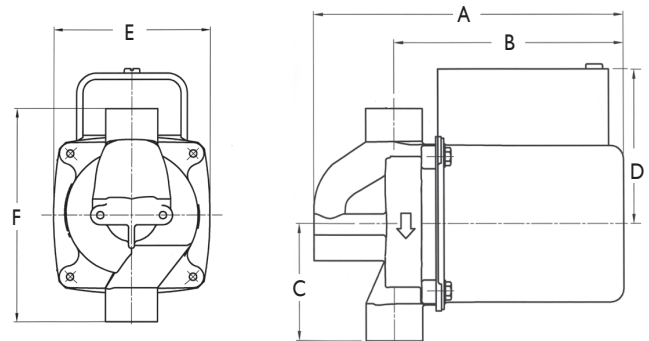

Sweat Connection Models

### 60 Hz Performance Curves

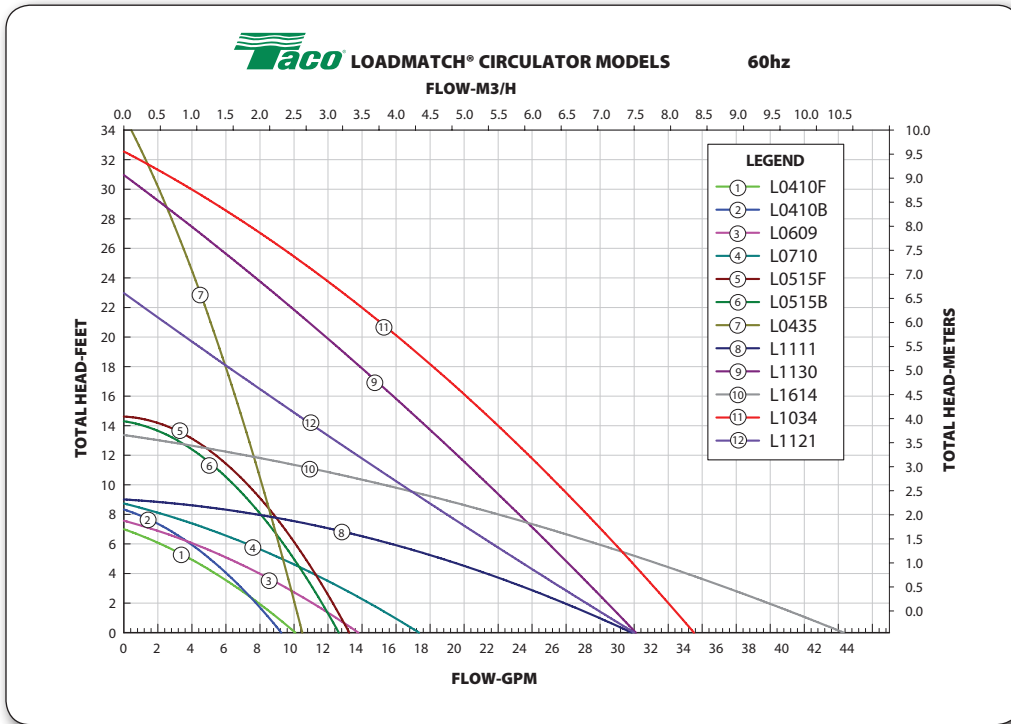

### 50 Hz Performance Curves

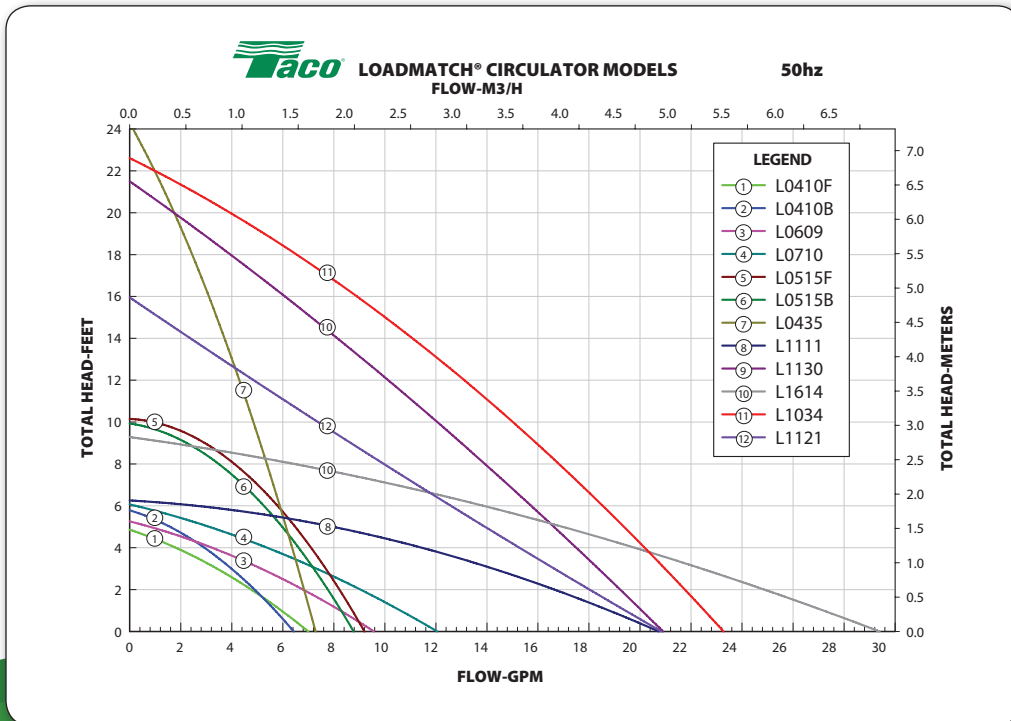

## Part I — General

### 1.1

#### WORK INCLUDED

- A. This Section governs the materials and installation of closed hydronic systems associated with building heating and cooling.

The following systems, where applicable, shall be installed as specified herein.

Hot Water Heating System

Chilled Water Cooling System

Dual Temperature Water System

Heat Pump Circulating System

Closed Circuit Cooling Tower System

Run-Around Heat Recovery System

### 1.2

#### EQUIPMENT SUBSTITUTION

- A. All items eligible for substitution require submission of request for substitution 10 days prior to bid date. This submittal shall include specific models and capacities of equipment and not just manufacturer's literature. The prior approval request package shall also include an engineered flow schematic showing that the manufacturer has a detailed understanding of the temperature cascade. This schematic shall be sealed

by a professional engineer. This schematic shall show the entering and leaving temperature, load, and flow at every terminal unit.

- B. In addition the prior approval package shall include an owner contact list for 50 single pipe distribution jobs this manufacturer has successfully installed over the last five years. A system performance guarantee shall also be provided along with manufacturer's liability policy cover page. This entire package must be received 10 days prior to bid. Only written approval issued via addendum will be notification of vendor approval. No verbal approvals will be acknowledged.

### 1.3

#### TESTING & APPROVING AGENCIES

- A. Where items of equipment are required to be provided with compliance to U.L., A.G.A., or other testing and approving agencies, the contractor may submit a written certification from any nationally recognized testing agency, adequately equipped and competent to perform such services, that the item of equipment has been tested and conforms to the same method of test as the listed agency would conduct.

### 1.4

#### SUBMITTAL DATA

- A. See Section 15000 for general submittal requirements.
- B. Provide manufacturer's literature for all products specified in this Section, which will be installed under this project.
- C. Provide performance curves for all pumps. Plot the specified operating point for each pump on its respective curve.
- D. Provide complete literature for all components of packaged systems. These include pump performance, heat exchanger calculations, expansion tank capacity, data for all accessories and valves and complete wiring diagrams specific to the exact unit to be supplied.

The wiring diagram shall indicate all required field and factory wiring.

- E. The submittal package shall include the engineered flow schematic as described in the substitution section.

## Part 2 — Products

### 2.1 SYSTEM

The LoadMatch distribution system shall include circulators, twin tees, design suite of software, and system guarantee. All the components shall be manufactured by a single source and that company shall provide a system guarantee. The manufacturer shall have a minimum of 50 single pipe distribution jobs installed within the last five years.

#### A. LoadMatch Circulator.

1. Circulators shall be Taco Model LoadMatch circulator or approved equal.
2. The circulator shall be water lubricated, direct drive, requiring no seals, couplers or bearing assembly. Ceramic shaft and carbon bearing construction shall be capable of running without fluid for 10 days without damage to shaft or bearings.
3. The circulator shall be repairable in-line without removal of the circulator from the piping using a stainless steel replaceable cartridge. Circulator shall be provided with a 3 year warranty.

4. The circulator shall incorporate a removable integral spring loaded flow check to eliminate fluid circulation when the pump is off.
5. The circulator shall incorporate an integral condensate baffle to eliminate condensation on the motor housing when supplying chilled water. Alternative manufacturing processes that delay the effect of condensation versus preventing it shall not be allowed. Specifically extra coating on the windings is not acceptable.
6. Circulator shall be rated for 200 psi working pressure at 220°F fluid temperature.
7. An integral variable speed drive (VSD) shall accept a 0-10 VDC or 4-20 MA modulating control signal to control the speed of the circulator motor. VSD shall incorporate an exercise sequence to run the pump for 20 seconds if there has been no run signal for 72 hours.
8. Circulator shall bear UL label.
9. The manufacturer shall guarantee system operation for one full heating season and one full cooling season,

to the extent that the HVAC system shall deliver the heating and cooling capacities as specified. The value of the guarantee shall be equal to the value of retrofitting the system to a two-pipe system.

#### B. Twin Tee

1. Tee fittings for terminal unit tie-in to system distribution piping shall be Taco Twin-Tee.
2. Twin-Tee fittings shall be made of ductile iron or bronze and shall be rated for 200 psi.
3. The fitting shall be manufactured with two system connections and two terminal unit connections. The system connections shall be offered in three types: sweat, threaded, and grooved. Terminal unit connections shall all be threaded.
4. The fitting shall include an internal baffle that prevents short circuiting of the terminal unit fluid from inlet to outlet.

#### C. Design software for temperature cascade

1. Manufacturer shall provide, as part of the system, a software package that allows the construction team to design,

document, and manage the temperature cascade in a single pipe distribution system. This software shall produce a flow diagram that sizes all equipment and pipe based on input loads and temperature differentials. The software shall document all of these design calculations in a flow schematic. The flow schematic shall show all loads, entering and leaving temperatures, and flow for each terminal unit. In the case of dual temperature systems and heat pumps, it shall document data for both heating and cooling modes.

D. System Guarantee

1. The manufacturer shall provide a written letter of guarantee certifying the performance of the entire system. This includes but is not limited to terminal unit performance.

**Part 3 —  
Execution**

**3.1 PUMPS**

A. General

1. All pumps, other than circulators, shall be fitted with a multi-purpose or balancing valve or other means of providing system balance.
2. All pumps shall be fitted with instrument test port on inlet and outlet ports unless otherwise indicated.
3. All pump groups (over one pump in parallel) on a single system shall utilize a check valve on the outlet to prevent reverse flows.

B. Circulator

1. Circulator shall be mounted with motor in horizontal position. It may be mounted vertically with motor up provided the system pressure is minimum of 20 psig.

### Contact Us

Taco engineers are at the forefront of Green Building hydronics, designing components and systems to help you meet the challenges of environmentally sensitive – and budget conscious – design and build. Visit our web site at **[www.taco-hvac.com](http://www.taco-hvac.com)** for more information or call us to talk to a Taco Green Building professional.

