

- EXTRUDED ALUMINUM CONSTRUCTION
- BARS ON 3/4 INCH CENTERS
- SCREW HOLE LOCATIONS STANDARD UNLESS OTHERWISE SPECIFIED
- WALL OR DUCT OPENING SHOULD BE DUCT SIZE +/- 1/8"
- MINIMUM SIZE: 6 X 4
- MAXIMUM SIZE: 48 X 48 ONE PIECE CONSTRUCTION
- AVAILABLE IN 1/4 INCH INCREMENTS
- FINISH: WHITE (W) ENAMEL OR SATIN ANODIZED (SA)
- Z-FRAME IS AVAILABLE AS A SPECIAL ORDER.

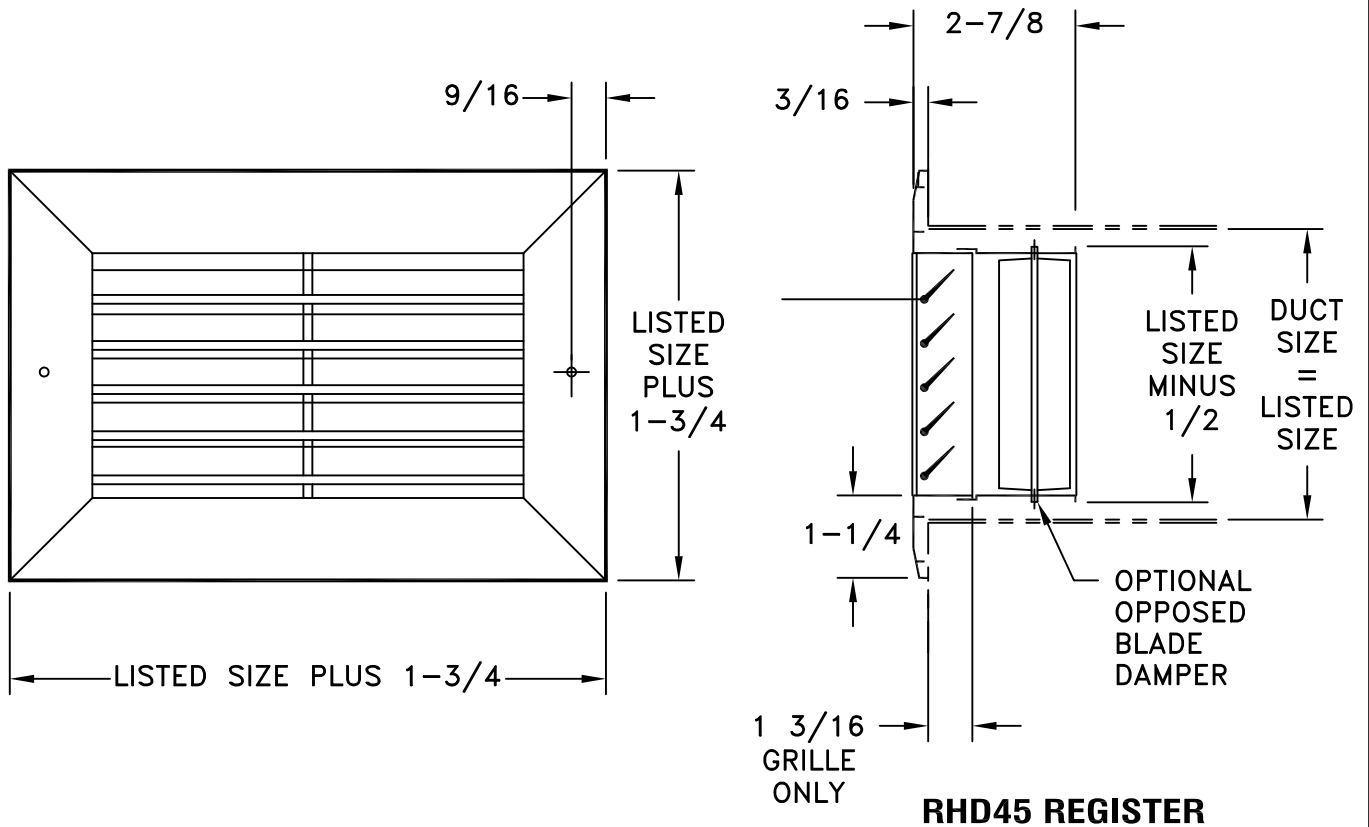

NOTE: All dimensions are +/- 1/16"

JOB NAME: _____	SUBMITTED BY: _____	DATE: 01/09/2017	SD-9124
LOCATION: _____		RH45/RHD45	
ARCHITECT: _____		Extruded Aluminum	
ENGINEER: _____		Fixed Horizontal	
CONTRACTOR: _____		Face Bars	