



**CEILING RADIATION DAMPER  
FOR WOOD TRUSS CEILING  
ASSEMBLIES. ETL CLASSIFIED  
UL263/E119  
REGISTER BOX \* SIDE INLET  
MODEL: 243FRD/243RD**



**QUALIFICATIONS:**

**ETL CLASSIFIED UL263/E119 CEILING DAMPER**

**1 Hour Rated for use in floor/ceiling and roof/ceiling design numbers:  
L521, L528, L546, L550, L558, L562, L563, L570, L574, L579, L585, L586, M503, P522, P531, P533, P538, P545, P547, P548, or P552.  
Meets NFPA 90A requirements.**

**DESCRIPTION:**

Ceiling dampers are designed to function as a heat barrier in air handling openings penetrating fire resistive membrane ceilings. The Model 243FRD has been especially designed to provide protection and for Simple installation in specific design wood truss ceiling assemblies.

The 243FRD assembly consist of a rectangular ceiling damper recessed in a sheet metal tapered register box (boot) with round inlet collar that accommodates a steel grill or register.

**CONSTRUCTION:**

1. Listed fusible link, 212 Degree F Standard.
2. Blades: 21Ga G60 roll-formed galvanized steel.
3. Blade Insulation: Non-asbestos classified.
4. Damper Frame: 21Ga. G60 Galvanized steel.
5. Steel Plenum: 24Ga Max. with round connector.
6. Class 0 or 1 Flexible duct connection by others.
7. Plaster flange with 1" wide by 1/2" Deep.
8. Steel grille/register (by Others). Standard clearance depth 2 1/2".
9. Max 144 square inches (Max. dimension of 14")

**Options:**

1. Non-standard temp. Listed fusible link 165 Degree Fahrenheit.
2. Installation support angles. 26" long.  
\* 2 @ Standard boot rail (2 Sides)  
\* 3/4" x 3/4" x 16 Ga angle ( four sides).
3. Available non-flanged (243RD).  
NOTE: Boot rail option not available on (243RD).
4. Plaster flange available in 1/2" or 1".
5. Boot size determines single or double blade conf.

**NOTE:** Building Code and Classification require damper installation in accordance with manufacturer's installation instructions.

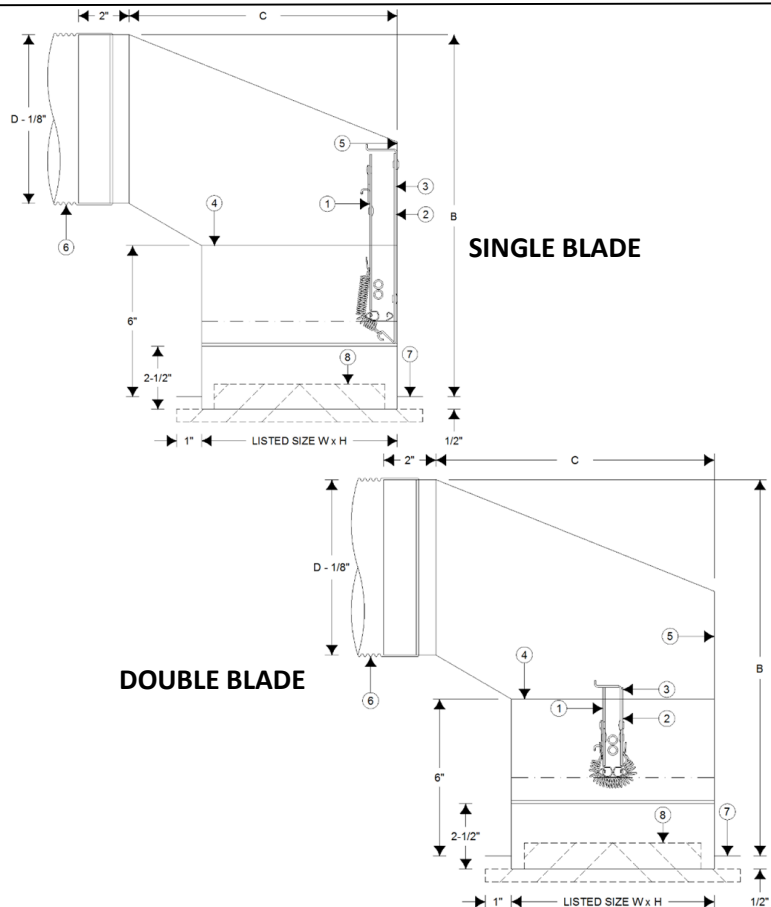

**DRYWALL LIP NOT INCLUDED IN HEIGHT DIMENSION**

**Approx. Dimensional Data**

| Available Sizes |                  |     |         |
|-----------------|------------------|-----|---------|
| W X H           | NOM. Duct Size D | B   | C       |
| 8 X 4           | 4"               | 13" | 8"      |
|                 | 5"               | 13" | 8"      |
| 10 X 4          | 4"               | 13" | 8"      |
|                 | 5"               | 13" | 7 3/4"  |
|                 | 6"               | 13" | 7 1/4"  |
| 12 x 4          | 6"               | 13" | 7 3/4"  |
|                 | 7"               | 13" | 7 1/2"  |
|                 | 8"               | 14" | 7       |
| 14 x 4          | 7"               | 13" | 7 1/2"  |
| 8 x 6           | 6"               | 13" | 10"     |
| 6 x 6           | 4"               | 13" | 8"      |
|                 | 5"               | 13" | 8"      |
|                 | 6"               | 13" | 8"      |
| 10 x 6          | 5"               | 13" | 9"      |
|                 | 6"               | 13" | 10"     |
|                 | 7"               | 13" | 9 1/4"  |
| 12 x 6          | 6"               | 13" | 9"      |
|                 | 7"               | 13" | 9 1/4"  |
|                 | 8"               | 14" | 10 1/4" |
|                 | 9"               | 15" | 11"     |
| 14 x 6          | 6"               | 13" | 10"     |
|                 | 7"               | 13" | 9 1/4"  |
|                 | 8"               | 14" | 9 3/4"  |
| 8 x 8           | 5"               | 13" | 10"     |
|                 | 6"               | 13" | 10"     |
|                 | 7"               | 13" | 9 3/4"  |
| 10 x 8          | 7"               | 13" | 9 3/4"  |
|                 | 8"               | 14" | 10 1/4" |
| 12 x 8          | 7"               | 13" | 9 3/4"  |
|                 | 8"               | 14" | 10 1/4" |
|                 | 9"               | 15" | 10"     |
| 14 x 8          | 6"               | 13" | 12"     |
|                 | 7"               | 13" | 12"     |
|                 | 8"               | 14" | 12"     |
|                 | 9"               | 15" | 12"     |

**W X H = NOMINAL GRILL/REGISTER SIZE CONTACT**

**MANUFACTURER FOR ADDITIONAL DIMENSIONS NOT LISTED.**