

**40MVC018 with 38MVC018
Comfort™ Series High Wall Duct-Free Split System
Cooling Only with Puron® Refrigerant**



Turn to the Experts.™

Submittal Data

Job Data: _____ Location: _____
 Buyer: _____ Buyer P.O.# _____ Carrier # _____
 Unit Number: _____ Model Number: _____
 Performance Data Certified By: _____ Date: _____



FEATURES

- 13 SEER
- Wireless remote standard
- Low voltage controls
- User selectable fan speeds (auto, low med., high)
- Indoor unit is powered from the outdoor unit
- Auto restart
- Diagnostics
- Dehumidification mode
- Sleep mode
- Auto swing
- Timer
- Cleanable filters
- Low ambient operation to -20°F (-28.9°C) with accessories

Indoor Unit - 40MVC / Outdoor Unit - 38MVC
 (Unless otherwise indicated, data applies to both indoor and outdoor models)

SYSTEM SIZE	018
REFRIGERANT	R-410A
PERFORMANCE	
Nominal Capacity	18,000
SEER	13
Airflow (Low/Med/High)	500 / 570 / 630
Performance at actual conditions:	Attached <input type="checkbox"/> Not Attached <input type="checkbox"/>
SOUND PRESSURE dBA	
Indoor (Low/Med/High)	43 / 45 / 46
Outdoor	57
SOUND POWER dBA	
Indoor (Low/Med/High)	54 / 56 / 57
Outdoor	68

ELECTRICAL	
System Voltage	208/230V
MCA (outdoor)	11
MOCP (outdoor)	20
Fan Motor (Indoor) (FLA)26
Motor Watts	31
CONTROLS	
Control Remote	Wireless
Control Voltage	Low Voltage
Interconnecting (indoor to outdoor) Wiring (0-50 ft.)	18 AWG
Interconnecting (indoor to outdoor) Wiring (50-65 ft.)	16 AWG
REFRIGERANT LINES (Insulate both lines)	
Mixed Phase Line (in.) OD	1/4
Vapor Line (in.) OD	1/2
Metering/Control Device	Capillary tube in outdoor unit

Condensate Pump:	Required <input type="checkbox"/>	Not Required <input type="checkbox"/>
Low Ambient Controls:	Required <input type="checkbox"/>	Not Required <input type="checkbox"/>
Crankcase Heater:	Required <input type="checkbox"/>	Not Required <input type="checkbox"/>
Wind Baffle:	Required <input type="checkbox"/>	Not Required <input type="checkbox"/>

Optional:

Compressor extended warranty 6-10 years:	Required <input type="checkbox"/>	Not Required <input type="checkbox"/>
All parts & labor 2-5 years:	Required <input type="checkbox"/>	Not Required <input type="checkbox"/>
All parts & labor 2-5 years + Compressor 6-10 years:	Required <input type="checkbox"/>	Not Required <input type="checkbox"/>

UNIT DIMENSIONS – INDOOR MODEL

Model Size	W in. (mm)	H in. (mm)	D in. (mm)	Operating Weight lb (kg)
18K	49.21 (1250)	12.80 (325)	9.06 (230)	36.4 (17)

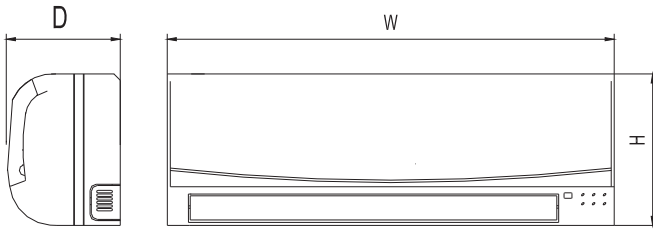

Fig. 1 – 40MVC Dimensions

A07336

UNIT CLEARANCES – INDOOR MODEL

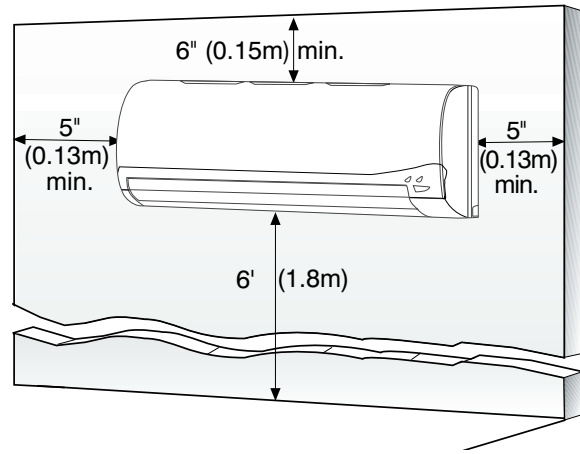

Fig. 2 – 40MVC Clearance

A07891

UNIT DIMENSIONS – OUTDOOR MODEL

Model Size	W in. (mm)	H in. (mm)	L1 in. (mm)	L2 in. (mm)	L3 in. (mm)	Weight lb (kg)
18K	33.07 (840)	27.36 (695)	22.05 (560)	14.17 (360)	13.19 (335)	116.6 (52.89)

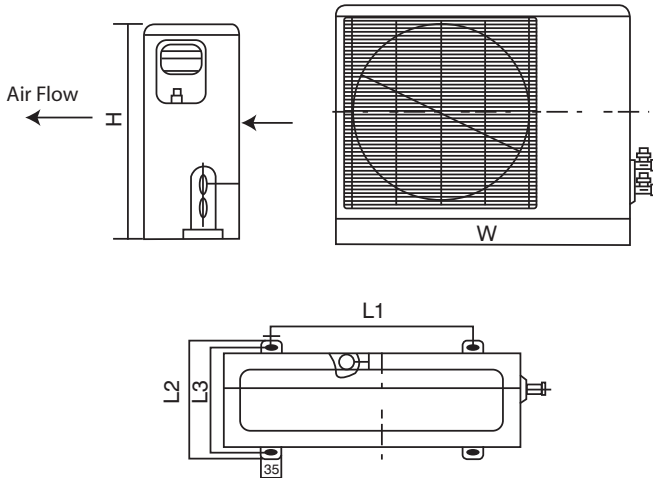

Fig. 3 – 38MVC Dimensions

A07337

UNIT CLEARANCES – OUTDOOR MODEL

UNIT	18k in. (mm)
A	24 (610)
B	36 (914)
C	24 (610)
D	12 (305)
E	12 (305)

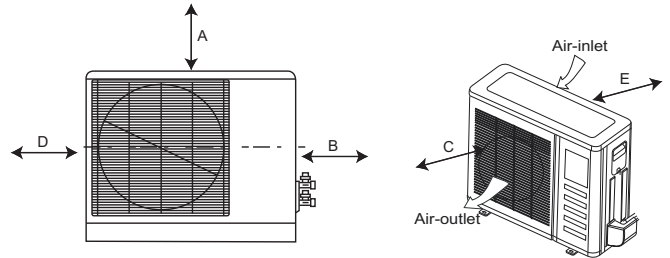

Fig. 4 – 38MVC Clearances

A07894