



FMU4P, FMC4P Product Specifications

HORIZONTAL FAN COILS

ALL MODELS

- 1-1/2, 2, 2.5, and 3 Tons
- Horizontal application only
- For use with R-410A refrigerant or R-22 with accessory TXV
- Accessory field-installed electric heat kits available in 5, 7.5, or 10 kW
- 40 VA 208/230v-1-60 transformer

FMC4P

- Horizontal return applications require field fabricated bottom cover
- Cabinets meet the requirement of 2% cabinet leakage rate at 1-in. w.c. of static pressure
- Cabinets constructed to prevent cabinet sweating
- Refrigerant lines and electrical connections can be run out the back or side of casing
- Primary and secondary drain connections exit from the back or side of the cabinet.

PERFORMANCE

- PSC motor on all models

EASY TO INSTALL AND SERVICE

- A-coil design for maximum surface area
- Multiple electrical, refrigerant lineset and drain line entry for application flexibility
- Sweat connections for long term reliability
- Grooved copper tubing

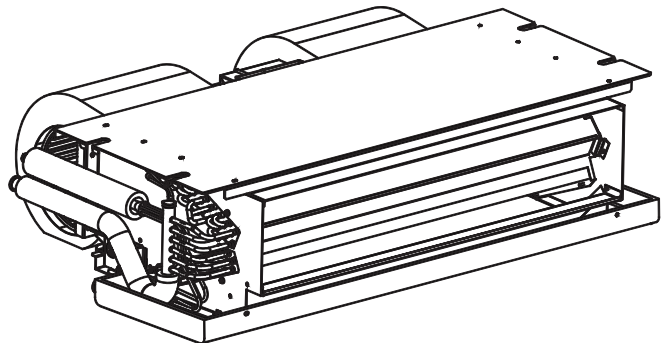

A13303

FMU4P - Uncased Horizontal Fan Coil

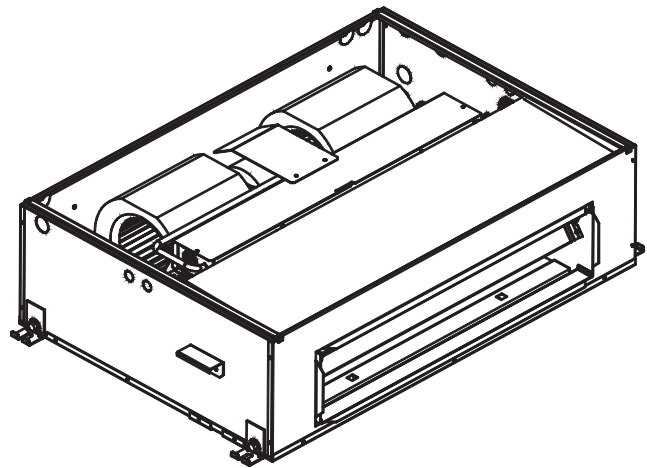

A13304

**FMC4P - Cased Horizontal Fan Coil
(Unit pictured upside down)**



ISO 9001
QMS-SAI Global



Use of the AHRI Certified TM Mark indicates a manufacturer's participation in the program. For verification of certification for individual products, go to www.ahridirectory.org.



Model Number	Tons	Nominal BTU	CFM (L/s)	Dimensions H x W x D in. (mm)	Ship Wt. lbs. (kg)
UNCASED					
FMU4P1800	1-1/2	18,000	600(283)	10-1/4 x 37-1/4 x 26-3/8 (260 x 946 x 670)	75 (34)
FMU4P2400	2	24,000	800(378)		75 (34)
FMU4P3000	2-1/2	30,000	1000(472)	10-1/4 x 49-1/4 x 26-3/8 (260 x 1251 x 670)	93 (42)
FMU4P3600	3	36,000	1200(566)		93 (42)
CASED					
FMC4P1800	1-1/2	18,000	600(283)	11 x 39-3/4 x 27-3/4 (282 x 1010 x 704)	109 (49)
FMC4P2400	2	24,000	800(378)		109 (49)
FMC4P3000	2-1/2	30,000	1000(472)	11 x 51-3/4 x 27-3/4 (282 x 1315 x 704)	135 (61)
FMC4P3600	3	36,000	1200(566)		135 (61)

FAN COIL MODEL NUMBER IDENTIFICATION GUIDE

	F	M	A	4	P	2400	A
F = Fan Coil		TYPE		INSTALLATION TYPE		REFRIGERANT	
M = Multi-Family							
U = Uncased		METERING DEVICE		NOMINAL CAPACITY		SALES CODE / FEATURES	
C = Cased							
4 = Environmentally Sound R-410A		NOMINAL CAPACITY		SALES CODE / FEATURES		SALES CODE / FEATURES	
P = R-410A piston							
1800 = 18,000 BTUH = 1-1/2 tons		NOMINAL CAPACITY		SALES CODE / FEATURES		SALES CODE / FEATURES	
2400 = 24,000 BTUH = 2 tons							
3000 = 30,000 BTUH = 2-1/2 tons		NOMINAL CAPACITY		SALES CODE / FEATURES		SALES CODE / FEATURES	
3600 = 36,000 BTUH = 3 tons							
A = Standard		NOMINAL CAPACITY		SALES CODE / FEATURES		SALES CODE / FEATURES	

ELECTRIC HEATER MODEL NUMBER IDENTIFICATION GUIDE

	EHK	3	05	B	
EHK = Electric Heater Kit		NOMINAL HEAT VALUE		SALES CODE / FEATURES	
Sales Code					
05 = 5 kW		NOMINAL HEAT VALUE		SALES CODE / FEATURES	
08 = 7.5 kW					
10 = 10 kW		NOMINAL HEAT VALUE		SALES CODE / FEATURES	
Engineering Code					

DIMENSIONS

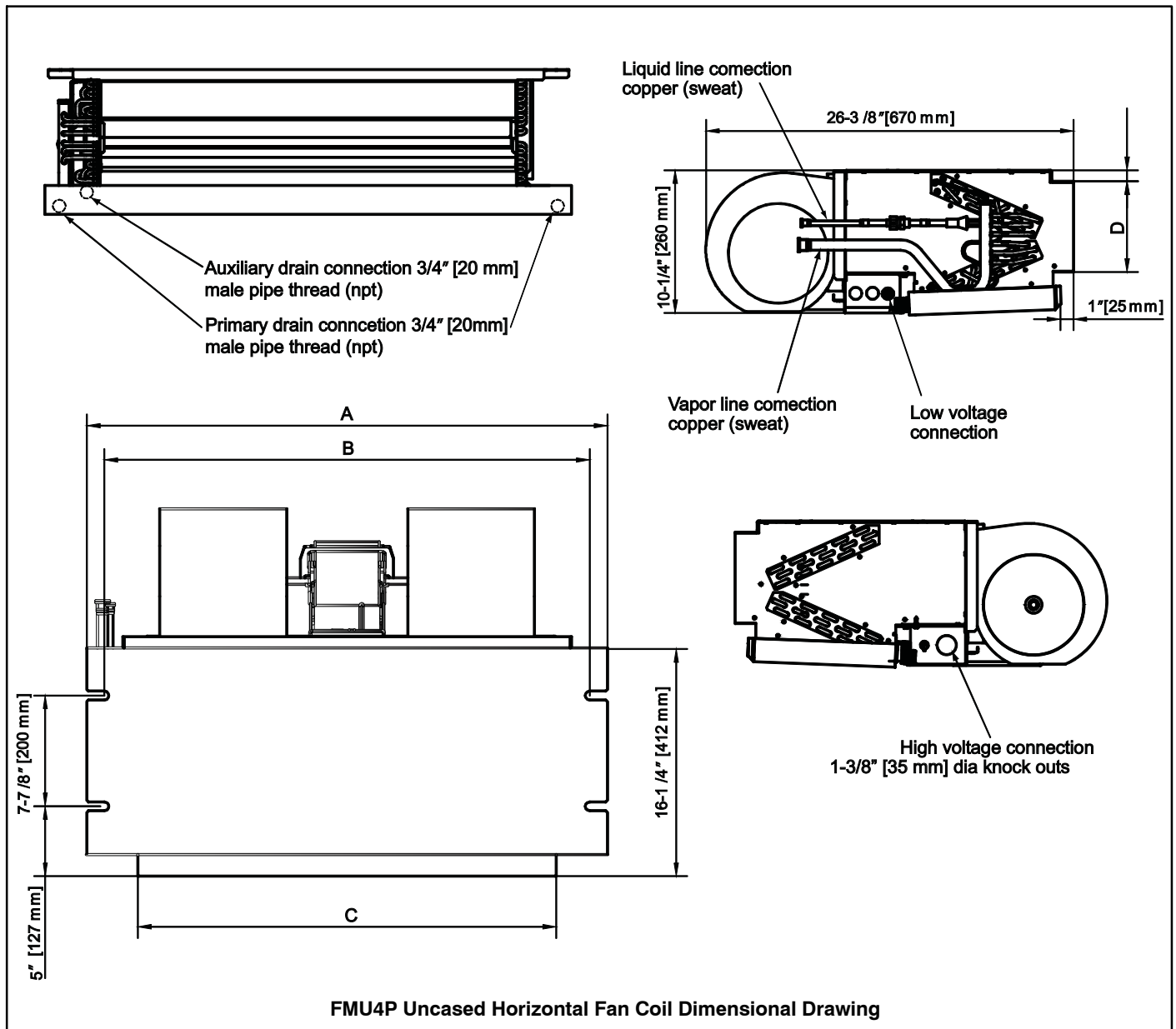

Model Size	Dimensions- inches (mm)				Unit Operating Weight lbs (kg)
	"A"	"B"	"C"	"D"	
18	37-1/4 (946)	34-11/16 (881)	30 (762)	6-1/2 (165)	75 (34)
24	37-1/4 (946)	34-11/16 (881)	30 (762)	6-1/2 (165)	75 (34)
30	49-1/4 (1251)	46-11/16 (1186)	42 (1067)	6-1/2 (165)	93 (42)
36	49-1/4 (1251)	46-11/16 (1186)	42 (1067)	6-1/2 (165)	93 (42)

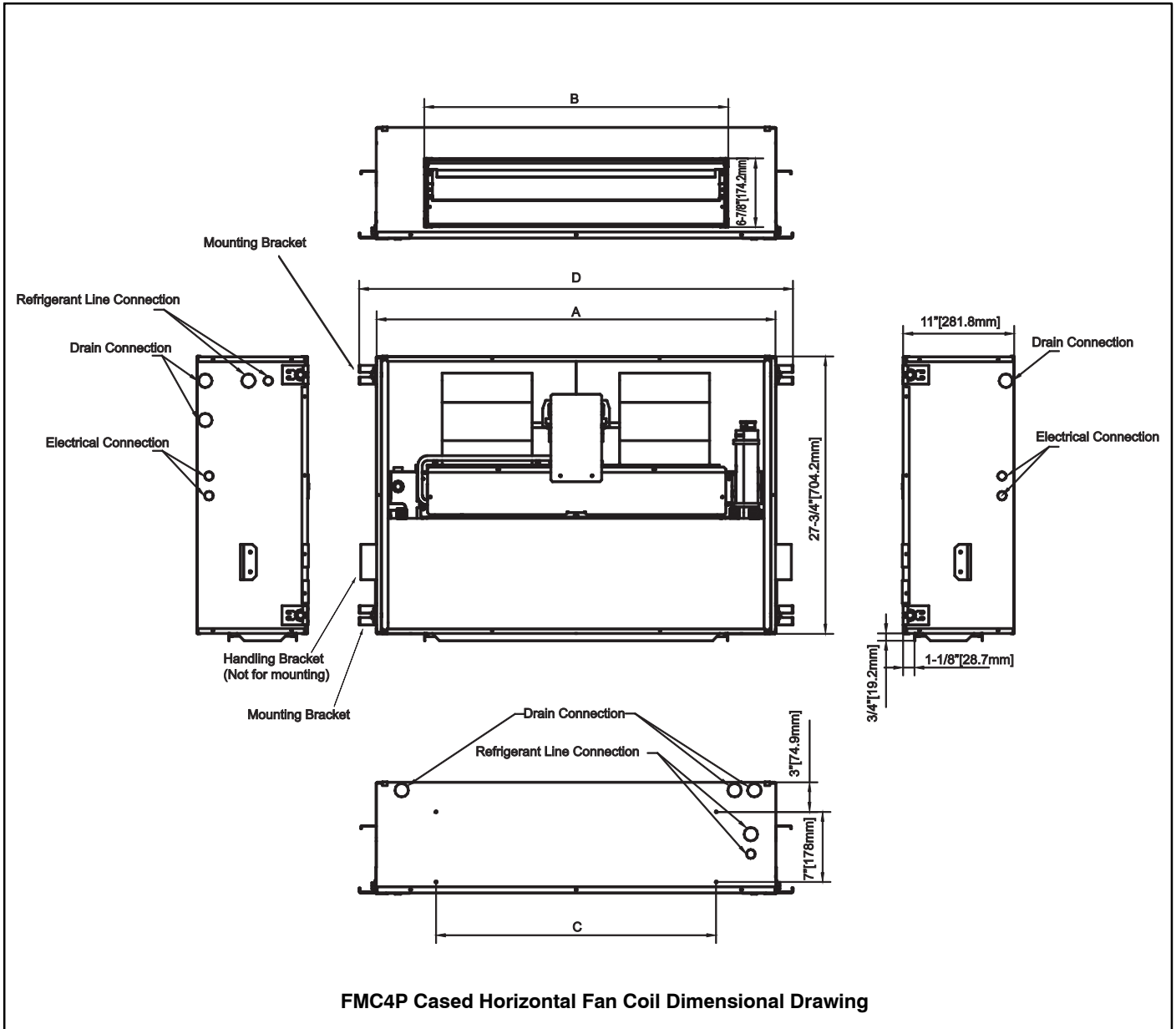

FMC4P Cased Horizontal Fan Coil Dimensional Drawing

Model Size	Dimensions- inches (mm)				Unit Operating Weight lbs (kg)
	"A"	"B"	"C"	"D"	
18	39-3/4 (1010)	30-3/8 (771)	28 (711)	43-3/8 (1101)	109 (49)
24	39-3/4 (1010)	30-3/8 (771)	28 (711)	43-3/8 (1101)	109 (49)
30	51-3/4 (1315)	42-3/8 (1076)	40 (1016)	55-3/8 (1406)	135 (61)
36	51-3/4 (1315)	42-3/8 (1076)	40 (1016)	55-3/8 (1406)	135 (61)

REQUIRED CLEARANCES - ALL MODELS inches (mm)			
No Heaters		All Sides	0
		From Supply Duct	0
With Heaters		All Sides	0
		From Supply Duct	0

PHYSICAL DATA

FM(U,C)4P	Unit Size			
	18	24	30	36
Nominal Cooling Capacity (BTUH)	18,000	24,000	30,000	36,000
COIL				
R-410A - Refrigerant Metering Device (Piston)*	50 (1.27mm)	56 (1.42mm)	67 (1.7mm)	69 (1.75mm)
Coil Configuration	A-Coil			
BLOWER & MOTOR				
Air Discharge	Horizontal			
Blower Type	Dual Blower Direct Drive			
CFM (Nominal)	600	800	1000	1200
Motor Type	PSC	PSC	PSC	PSC
Motor HP	1/8	1/8	1/3	1/3
Rated RPM	1075	1075	1600	1600
Motor Speeds	3	3	3	3
FILTER				
Field Installed – in. (mm)	Qty. 2– 16x20x1 (406x508x25)	Qty. 2– 16x20x1 (406x508x25)	Qty. 2– 20x20x1 (508x508x25)	Qty. 2– 20x20x1 (508x508x25)
CONNECTIONS (Sweat)				
Suction – in. (mm)	3/4 in. (19 mm)			
Liquid – in. (mm)	3/8 in. (9.5 mm)			
Condensate (MPT) – in. (mm)	3/4 in. (19 mm)			
ELECTRICAL DATA				
Voltage	208/230	208/230	208/230	208/230
Hertz	60	60	60	60
Minimum Circuit Ampacity	1.32	1.32	2.2	2.2
Maximum Circuit Protector	15 (A)	15 (A)	15 (A)	15 (A)

* The piston included with the fan coil is unique to this product and **CANNOT** be replaced with the piston shipped with outdoor unit. Refer to the AHRI ratings to check if your combination can use the piston shipped with the unit or requires an accessory TXV.

PERFORMANCE DATA

AIRFLOW PERFORMANCE (CFM)

Use for Selecting Electric Heat Speed

Model	Motor Speed	CFM Dry Coil without Filter or Electric Heat						
		External Static Pressure-Inches W.C. (kPa)						
		0 (.0)	0.05 (.01)	0.1 (.02)	0.15 (.04)	0.2 (.05)	0.25 (.06)	0.3 (.07)
18	Low	762	724	686	642	598	513	448
	Medium	1033	981	932	876	819	735	667
	High	1062	1007	953	888	825	764	722
24	Low	762	724	686	642	598	513	448
	Medium	1033	981	932	876	819	735	667
	High	1062	1007	953	888	825	764	722
30	Low	1200	1152	1116	1073	1039	989	924
	Medium	1331	1285	1242	1205	1165	1121	1050
	High	1449	1402	1361	1322	1284	1235	1198
36	Low	1200	1152	1116	1073	1039	989	924
	Medium	1331	1285	1242	1205	1165	1121	1050
	High	1449	1402	1361	1322	1284	1235	1198

AIRFLOW PERFORMANCE (CFM)

Use for Selecting Cooling and Heat Pump Speed

Model	Motor Speed	CFM Wet Coil without Filter or Electric Heat						
		External Static Pressure-Inches w.c. (kPa)						
		0 (.0)	0.05 (.01)	0.1 (.02)	0.15 (.04)	0.2 (.05)	0.25 (.06)	0.3 (.07)
18	Low	747	671	623	575	528	469	397
	Medium	996	912	833	765	683	609	518
	High	1051	974	888	816	742	665	576
24	Low	747	671	623	575	528	469	397
	Medium	996	912	833	765	683	609	518
	High	1051	974	888	816	742	665	576
30	Low	1211	1150	1069	1017	958	906	849
	Medium	1313	1261	1216	1151	1105	1051	984
	High	1428	1377	1315	1244	1198	1148	1089
36	Low	1211	1150	1069	1017	958	906	849
	Medium	1313	1261	1216	1151	1105	1051	984
	High	1428	1377	1315	1244	1198	1148	1089

— Shaded boxes represent airflow outside the required 300-450 cfm/ton.

NOTES:

1. Airflow data is without filter or electric heat accessory. Heater adds 0.05" static.
2. Use dry coil data for determining electric heater airflow.
3. Use wet coil data for determining cooling airflow.

REQUIRED CFM RANGE

Size	CFM	
	Min	Max
18	450	675
24	600	900
30	750	1125
36	900	1350

PERFORMANCE DATA (cont.)

GROSS COOLING CAPACITIES (mbh)

Unit Size	INDOOR COIL AIR		SATURATED TEMPERATURE LEAVING EVAPORATOR °F (°C)														
			35 (2)			40 (4)			45 (7)			50 (10)			55 (13)		
	CFM	EWB	TC	SHC	BF	TC	SHC	BF	TC	SHC	BF	TC	SHC	BF	TC	SHC	BF
18	525	72 (22)	40	21	0.00	36	19	0.00	32	17	0.01	27	15	0.03	22	12	0.04
		67 (19)	33	22	0.04	29	19	0.04	24	17	0.04	19	15	0.04	14	12	0.05
		62 (17)	26	22	0.05	22	20	0.05	18	17	0.05	14	14	0.08	12	12	0.23
	600	72 (22)	45	24	0.00	40	21	0.00	35	19	0.03	30	16	0.04	24	14	0.05
		67 (19)	36	24	0.05	32	22	0.05	27	19	0.05	22	16	0.06	15	14	0.06
		62 (17)	29	24	0.06	25	22	0.06	20	19	0.06	16	16	0.09	13	13	0.25
	675	72 (22)	49	26	0.00	44	23	0.00	38	20	0.04	32	18	0.05	26	15	0.06
		67 (19)	40	26	0.06	35	24	0.06	29	21	0.07	23	18	0.07	17	15	0.07
		62 (17)	32	27	0.07	27	24	0.07	22	21	0.07	17	17	0.10	14	14	0.26
24	700	72 (22)	54	27	0.00	48	25	0.00	42	22	0.04	36	19	0.06	29	16	0.06
		67 (19)	44	28	0.06	39	25	0.07	33	22	0.07	26	19	0.07	18	16	0.07
		62 (17)	35	29	0.07	30	26	0.07	24	23	0.07	19	19	0.11	16	16	0.26
	800	72 (22)	59	30	0.00	53	27	0.01	47	24	0.06	39	21	0.07	31	18	0.08
		67 (19)	48	31	0.08	42	28	0.08	36	25	0.08	28	21	0.09	20	18	0.09
		62 (17)	39	32	0.09	33	28	0.09	26	25	0.09	22	22	0.13	18	18	0.28
	900	72 (22)	64	33	0.00	57	30	0.03	50	26	0.07	43	23	0.09	34	19	0.09
		67 (19)	52	34	0.09	46	30	0.10	39	27	0.10	31	23	0.10	22	20	0.10
		62 (17)	42	35	0.10	35	31	0.10	29	28	0.10	24	24	0.15	20	20	0.29
30	875	72 (22)	64	31	0.04	59	29	0.05	53	26	0.05	45	23	0.06	37	20	0.06
		67 (19)	53	33	0.06	48	31	0.06	41	28	0.06	34	25	0.06	25	21	0.06
		62 (17)	43	35	0.06	38	32	0.06	32	30	0.06	27	27	0.14	23	23	0.28
	1000	72 (22)	69	34	0.05	63	31	0.06	57	28	0.07	49	25	0.07	40	22	0.07
		67 (19)	57	36	0.07	51	33	0.07	44	30	0.07	36	27	0.07	27	24	0.07
		62 (17)	47	38	0.07	41	36	0.07	34	33	0.08	30	30	0.17	25	25	0.30
	1100	72 (22)	72	35	0.07	66	33	0.07	59	30	0.08	51	27	0.08	42	23	0.08
		67 (19)	60	38	0.08	54	35	0.08	46	32	0.08	38	29	0.08	29	25	0.08
		62 (17)	49	41	0.08	43	38	0.08	37	36	0.09	32	32	0.19	27	27	0.31
36	1050	72 (22)	69	34	0.06	63	32	0.07	56	29	0.07	49	26	0.08	40	22	0.08
		67 (19)	57	37	0.08	51	34	0.08	44	31	0.08	36	28	0.08	27	24	0.08
		62 (17)	46	39	0.08	40	37	0.08	34	34	0.08	30	30	0.18	25	25	0.30
	1200	72 (22)	73	36	0.08	67	34	0.08	60	31	0.09	52	28	0.09	42	24	0.09
		67 (19)	61	40	0.09	54	37	0.09	47	34	0.10	39	30	0.10	29	27	0.09
		62 (17)	50	43	0.09	43	40	0.09	37	37	0.10	33	33	0.21	28	28	0.33
	1350	72 (22)	77	39	0.10	71	36	0.10	63	33	0.10	55	30	0.11	45	26	0.11
		67 (19)	64	42	0.11	57	40	0.11	50	36	0.11	41	33	0.11	31	29	0.11
		62 (17)	52	46	0.11	46	43	0.11	41	41	0.13	36	36	0.24	30	30	0.35

CFM – Cubic Ft per Minute
 SHC – Gross Sensible Capacity 1000 Btuh

EWB – Entering Wet Bulb °F (°C)
 BF – Bypass Factor

LWB – Leaving Wet Bulb °F (°C)
 MBH – 1000 Btuh

TC – Gross Cooling Capacity 1000 Btuh

NOTES:

- Contact manufacturer for cooling capacities at conditions other than shown in table.
- Formulas:

$$\text{Leaving db} = \text{entering db} - \frac{\text{sensible heat cap.}}{1.09 \times \text{CFM}}$$

Leaving wb = wb corresponding to enthalpy of air leaving coil (h_{lwb})

$$h_{lwb} = h_{ewb} - \frac{\text{total capacity (Btuh)}}{4.5 \times \text{CFM}}$$

where h_{ewb} = enthalpy of air entering coil. Direct interpolation is permissible. Do not extrapolate.

- SHC is based on 80°F (27°C) db temperature of air entering coil. Below 80°F (27°C) db, subtract (Correction Factor x CFM) from SHC. Above 80°F (27°C) db, add (Correction Factor x CFM) to SHC.
- Bypass Factor = 0 indicates no psychometric solution. Use bypass factor of next lower EWB for approximation.

SHC CORRECTION FACTOR

BYPASS FACTOR	ENTERING AIR DRY-BULB TEMPERATURE (°F)					
	79	78	77	76	75	Under 75
	81	82	83	84	85	Over 85
	ENTERING AIR DRY-BULB TEMPERATURE (°C)					
	26	25	25	24	24	Under 75
	27	28	28	29	29	Over 85
Correction Factor						
0.10	.098	1.96	2.94	3.92	4.91	Use formula shown below
0.20	0.87	1.74	2.62	3.49	4.36	
0.30	0.76	1.53	2.29	3.05	3.82	

Interpolation is permissible.

Correction Factor = 1.09 x (1 - BF) x (db - 80)

ESTIMATED SOUND POWER LEVEL (dBA)

UNIT SIZE	CONDITIONS		OCTAVE BAND CENTER FREQUENCY						
	CFM	Ext Static Pressure	63	125	250	500	1000	2000	4000
18	600	0.18	47.9	51.6	46.6	49.6	47.6	38.7	34.7
24	800	0.18	47.9	51.3	50.7	51.1	46.9	41.6	35.7
30	1000	0.24	47.9	55.7	50	54.3	51.9	43.8	39.3
36	1200	0.24	47.9	55.6	49.2	53.1	49.6	43.4	38.2

* Estimated sound power levels have been derived using the method described in the 1987 ASHRAE HVAC Systems & Applications Handbook, Chapter 52, p. 52.7.

OPTIONAL FIELD-INSTALLED ELECTRIC HEAT PACKAGES

HEATER PART NUMBER WITH TDR	SIZES USED WITH	NOMINAL kw @ 240V	HEATER VOLTS-PHASE (60 Hz)	HEATER CAPACITY (MBH)		MIN. CIRCUIT AMPACITY		MAX. FUSE OR BREAKER (HACR) AMPACITY		APPROX. SHIP WGT. LBS. (kg)
				208	240	208	240	208	240	
				EHK305B	All	5	208/240-1	12.8	17.1	
EHK308B	All	7.5	208/240-1	20.5	27.3	36.1	41.7	50	50	10 (4.5)
EHK310B	All	10	208/240-1	25.7	34.2	45.1	52.1	60	60	10 (4.5)

OTHER ACCESSORIES

Kit Number	Description	Used on sizes
NASA00101GF	Louvered Panel with Filter Rack - Small	18, 24
NASA00201GF	Louvered Panel with Filter Rack - Large	30, 36
NASA00101CC	Access Panel - Small	18, 24
NASA00201CC	Access Panel - Large	30, 36
NAEA20101TX	TXV Kit R-22	18, 24, 30, 36
NAEA40501TX	TXV Kit R-410A	18, 24, 30
NAEA40601TX	TXV Kit R-401A	36
EBAC01CTK	PVC Condensate Trap Kit (50 pack)	All