



TECHNICAL GUIDE

**SINGLE PACKAGE
AIR CONDITIONER/ELECTRIC HEAT
14 SEER – R-410A – THREE PHASE
3 THRU 5 NOMINAL TONS - 460V
MODELS: PCE4*36 THRU 60**



Due to continuous product improvement, specifications are subject to change without notice.

Visit us on the web at
www.upgnet.com and www.york.com
Additional rating information can be found at:
www.ahridirectory.org

WARRANTY SUMMARY*

Standard 1-Year limited parts warranty.

Standard 5-Years limited compressor warranty.

* Extended warranty requires online registration within 90 days of purchase for replacement or closing for new home purchase. See limited warranty certificate in User's Information Manual for details.

DESCRIPTION

These packaged cooling/heating air conditioners are designed for outdoor installation. Only utility and duct connections are required at the point of installation.

FEATURES

- **Operating Efficiency** - All PCE4 air conditioner models are rated at 14.0 SEER and 11.0 EER for cooling operation.
- **On Site Flexibility** - All model sizes use a compact design cabinet in one of two footprints. This provides installer flexibility for placing the proper capacity unit on curbs or pads with the smallest footprint after the internal load has been determined. Field convertible duct connections from side shot to down shot allows the installer to have greater flexibility with less inventory.
- **Lower Installation Cost** - Installation time and costs are reduced by easy power and control wiring connections. The small base dimension means less space is required on the ground or roof. All units are completely wired, charged with R-410A and tested prior to shipment. Test stations using a state-of-the-art computerized process system are used to insure product quality. Refrigerant charge and component part numbers are verified via computers during assembly. Vital run test statistics such as system pressure, motor currents, air velocity and temperature, unit vibration, and gas system safeties are monitored and recorded by the system to insure unit performance. Equal size side supply and return duct connections allow easy connection of ducts to match low crawl spaces without transition pieces.
- **Utility Connections Made Easy** - Electric utility access provided through the bottom or the side of the unit. Utility connections can be made quickly and with a minimum amount of field labor. A field supplied and field installed electrical disconnect switch must be installed.
- **Convertible Airflow Design** - The bottom duct openings are covered when they leave the factory, ready to be used for a side supply/side return application. If a bottom supply/bottom return application is desired, simply remove the two panels from the bottom of the unit and place them in the side supply/side return duct openings. No panel cutting is required and no accessory panel is necessary. Convertible airflow design allows maximum field flexibility and minimum inventory.
- **Condensate Pan** - A corrosion-resistant, long-lasting, water-tight pan is positioned below the evaporator coil to collect and drain all condensate, preventing build-up of stagnant condensate. The condensate pan conforms to ASHRAE 62-89 standards (Ventilation for Acceptable Indoor Air Quality).
- **Condensate Drain** - The 3/4 inch NPT female connection is rigidly mounted to assure proper fit and leak tight seal.
- **Durable Finish** - The cabinet is made of G90 galvanized steel with a powder paint coating for appearance and protection. The pre-treated galvanized steel provides a better paint-to-steel bond, which resists corrosion and rust creep. Powder paint finish ensures less fading when exposed to sunlight, and provides superior corrosion resistance (1000 hour salt spray tested).

Continued on next page.

- **Full Perimeter Base Rails** - The easily removable base rails provide a solid foundation for the entire unit and protects the unit during shipment. The rails provide fork lift access from all sides, and rigging holes are also provided so that an overhead crane can be used to place the units on a roof. On applications where the unit is placed on a pad, the base will keep the unit off the pad to deter corrosion. On applications where height is limited, the base rails may be removed by removing 2 screws in each corner.
- **Attractive Appearance** - A single-piece top cover containing a top-discharge condenser fan arrangement requires less square footage on installation and provides a wider variety of installations. The one-piece design adds greater water integrity. Rounded corners with water drip edges add to the attractive appearance.
- **Top Discharge** - The top-discharge outdoor fan does not disrupt neighboring areas or dry out vegetation surrounding the unit. The warm air from the top mounted fan is blown up and away from the structure and any landscaping.
- **Outdoor Coil Grille** - All models utilize a stamped slotted design which provides superior impact protection against small objects during transit and after installation.
- **Low Operating Sound Level** - The upward air flow carries the normal operating noise up and away from the living area. The rigid top panel effectively isolates noise. Isolator mounted compressor and the rippled fins of the outdoor coil muffle the normal fan motor and compressor operating sounds. The unique formed base pan also aids in sound attenuation with its structural design.
- **Fan System** - All models operate over a wide range of design conditions with a standard ECM indoor fan motor. These units easily match all types of applications and provide greater on-site flexibility to match comfort requirements. The cooling speed is factory-set and can be field-adjusted to a second speed. The heating speed is factory set to maintain mid point rise at the units heating input, but can be field adjusted. This allows maximum comfort conditions.
- **Simple Control Circuit** - Field thermostat wiring connects to color coded wire leads using twist on wire connections. Cooling controls use contactor and relays for simple application and troubleshooting. Mate-n-lock plug connectors are used. The electrical control box is not located in the compressor compartment. The controls are mounted to allow the separate access panel to be removed for trouble shooting and maintenance without affecting the normal system operating pressures. All wiring internal to the unit is color/number coded.
- **Protected Compressor** - The compressor is internally protected against high pressure and temperature. This is accomplished by the simultaneous operation of high pressure relief valve and a temperature sensor which protect the compressor if undesirable operating conditions occur.
- **Pressure Switches** - A high pressure switch is standard in all units. It is an automatic reset switch. When discharge pressure reaches 650 psi, the compressor will de-energize until pressure reaches 450 psi.
- **Exclusive Coil Design** - Grooved copper tubes and enhanced aluminum fin construction improves heat transfer for maximum efficiency and durability for long-lasting durability and efficient operation. Indoor coils will use tin-coated copper tubing with aluminum fins for effective heat transfer.
- **Electric Heat** - All electric heat models use 6HK electric heat, which are available in 460V/3/60 10kW to 25kW.
- **Low Maintenance** - Long life, permanently lubricated condenser and evaporator fan motor bearings need no annual maintenance, adding greater reliability to the unit. Slide-out blower assembly and evaporator coil assembly can be easily removed for cleaning.
- **Easy Service Access** - Individual access panels are provided in access to all major components - compressors, evaporator coils, blower, controls/electric heat kits, filters, etc. that makes servicing easy. Removing these panels allow easy removal of the components such as the blower assembly for maintenance and ease of troubleshooting.
- **Replacement Parts** - The installer requires no special training to replace any of the components of these units and the number of new components have been reduced to minimize the inventory of unique parts.

NOMENCLATURE

PCE	4	A	36	3	1	A
1	2	3	4	6	8	9
1. Model Family PCE - packaged A/C with electric heat, PHE - packaged with electric heat, PCG - packaged A/C with gas heat, PHG - packaged heat pump with gas heat.			5. Gas Heating Input BTU/Hr x 1000 050 = 50,000 BTU/Hr. input, blank = electric heat			
2. Nominal Cooling Efficiency 4 = 14 SEER, 6 = 16 SEER, etc.			6. Voltage-Phase-Frequency 2 = 208/230-1-60, 3=208/230-3-60, 4 = 460-3-60			
3. Cabinet Size A = small 35 x 51, B = large 45 x 51			7. NOx Approval X = low-NOx, blank = not low-NOx			
4. Nominal Air Conditioning Cooling Capacity BTUx1000 24 = 24,000 BTU, etc.			8. Generation Level 1 = first generation			
Examples: PHE4B4221A is a packaged heat pump, 14 SEER, 3-1/2 ton, large cabinet, 230 volt, single phase model, (first generation, first release).			9. Revision Level A = original release, B = second release			

COMPONENT LOCATION

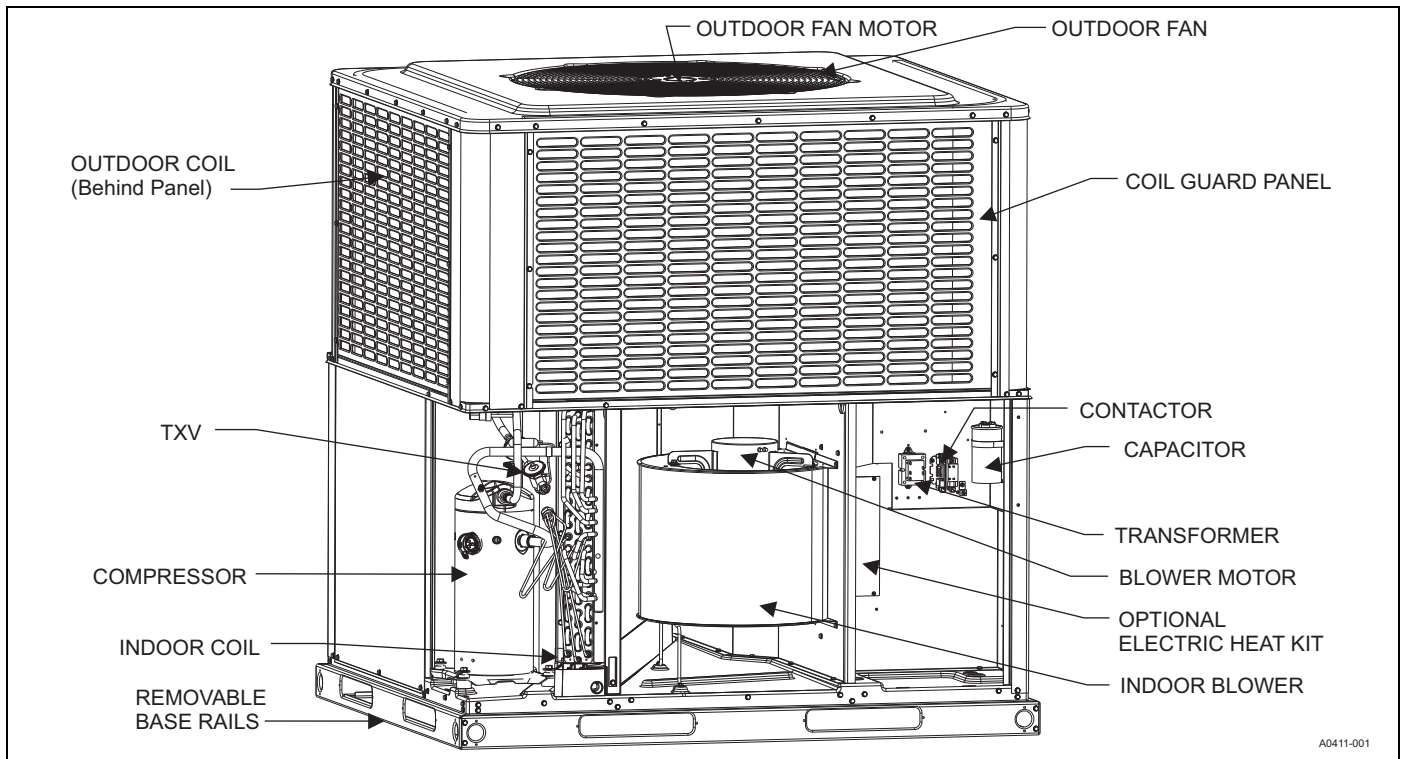

UNIT LIMITATIONS

Model	Unit Voltage	Unit Limitations		
		Applied Voltage		Outdoor DB Temp
		Min	Max	Max (°F)
PCEA36	460-3-60	432	504	125
PCEB48				
PCEB60				

ACCESSORIES

- **Economizer for Downflow Applications (S1-2EE04708424, S1-2EE04708524)** - Modulating integrated economizer provides simultaneous operation between mechanical cooling and economizer operation. Independent blade design insures proper control and less than 1% leak rate. Includes hood and mesh bird screen filter integrated into the hood, dry bulb sensor and relief damper. Separate field accessories of single/dual enthalpy kits are also available.
- **Economizer for Horizontal Applications (S1-2EE04708624, S1-2EE04708724)** - Modulating integrated economizer provides simultaneous operation between the mechanical cooling and economizer operation. Independent blade design insures proper control and less than 1% leak rate. Includes hood and mesh bird screen filter integrated into hood, dry bulb sensor and relief damper. Separate field accessories of single enthalpy and dual enthalpy are available.
- **Single/Dual Enthalpy Sensor (S1-2EC04700624)** - Sensor replaces dry bulb sensor standard in economizer kit. Provides improved economizer operation by sensing the dry bulb temperature from outdoors plus the enthalpy content of the outdoor air.
- **CO2 Sensor Kit (S1-2AQ04700824)** - Sensor kit detects CO2 levels automatically and overrides the economizer when CO2 levels rise above the preset limits.
- **Outdoor Temperature Sensor Kit (S1-2EC04700724S1-2EC04700724v)** - Additional outdoor air temperature sensor kit used with economizers.
- **Filter/Frame Kit (Kit provided) (S1-1FF0602, S1-1FF0601)** - Kit contains the necessary hardware to field install return air filters into the base unit. The filter rack is suitable for either 1" or 2" filters. (filters not supplied).
- **Motorized Fresh Air Damper (S1-2MD04705224, S1-2MD04705124)** - Designed for duct mounted side supply/return and unit mounted down supply/return applications. Damper capable of providing 0% through 50% of outdoor air (field supplied). Closes on power loss, includes hood and screen assembly.
- **Low Ambient Kit (S1-2LA04700824)** - Kit provides necessary hardware to convert unit to operate in cooling cycle down to 0° F. Standard unit operation 45° F.
- **Rectangle to Round (Horizontal) Adapter (S1-1AK0110, S1-1AK0111)** - Kit includes one supply and one return air rectangle to round duct adapter. Adapters are preformed and designed to fit over current horizontal duct openings on the base unit. Transition is from rectangle to 12" round for the 1AK0110 kit and from rectangle to 14" round for the 1AK0111 kit.
- **Rectangle to Round (Downflow) Adapter (S1-1AK0108, S1-1AK0109)** - Kit includes one supply and one return air rectangle to round duct adapter. Adapters are preformed and designed to fit into current downflow duct openings on the roof curb. Transition is from rectangle to 16" round for the 1AK0108 kit and from rectangle to 18" round for the 1AK0109 kit.
- **Roof Curbs (S1-1RC0503, S1-1RC0501)** - NRCA approved curbs provide proper fit to base unit for rooftop installations. Curbs are designed to be assembled through hinge pins in each corner. Kit also provides seal strip to assure an air tight seal. These are 8 inch high roof curbs.
- **Roof Curbs (S1-1RC0504, S1-1RC0502)** - NRCA approved curbs provide proper fit to base unit for rooftop installations. Curbs are designed for assembly through hinge pins in each corner. Kit also provides seal strip to assure air tight seal. These are 14 inch high roof curbs.
- **Manual Outdoor Damper (S1-1FA0502, S1-1FA0501)** - Provides 0% through 50% outdoor air capability (field adjustable). Designed for duct mounted side supply/return applications and unit mounted down supply/return applications. Includes hood and screen assembly.
- **Base Rail Hole Cover Kit (S1-1HC0101)** - Kit provides necessary hardware to close off openings in base rails to block off openings, i.e. prevent animal entrance.
- **Loss of Charge Sensor (S1-2LC00024)** - Kit provides Loss of Charge sensor and wiring to provide safe shutdown of compressor.
- **Transition Curb Kits (S1-1TC01*)** - Adapter kits to allow field use of pre-existing installed roof curbs to match PHE4 footprint to Affinity roof curbs, Carrier, Trane, or Goodman curb footprints. Curb adapters are optional for current generation Carrier replacements but are recommended for previous generation applications. Refer to the PCE4 price pages for more details.
- **Single-Point Wiring Kits - (S1-2SPWK031 through 037)** - Kit provides terminal block, fuse blocks and wiring to allow units with electric heat to be connected to a single source of incoming power.
- **Wall Thermostat** - The units are designed to operate with standard, 24-volt electronic non power stealing and electro-mechanical thermostats. All units can operate with single stage heat/single stage cool thermostats - with or without the economizer.

* For additional kit numbers refer to the price pages.

GUIDE SPECIFICATIONS

GENERAL

Units shall be manufactured by Unitary Products in an ISO 9001 certified facility. These packaged cooling and heating air conditioners are designed for outdoor installation. Only utility and duct connections are required at the point of installation. Air conditioning units provide electric cooling and heating with field installed electric heat kits from 10 kW to 25 kW for heating operation.

DESCRIPTION

Units shall be factory-assembled, single packaged, air conditioners with electric cooling/electric heating units, designed for outdoor installation. They shall have built in, equal size, field convertible duct connections for supply/return or horizontal supply/return. The units shall be factory wired, piped, charged with R-410A refrigerant and factory tested prior to shipment. All models shall be rated in accordance with DOE and AHRI test procedures for both heating and cooling operation. Units shall be CSA listed to the UL 1995/CAN/CSA No. 236-M90 standards.

- **Operating Efficiency** - All models shall be rated at a minimum of 14.0 SEER and 11.0 EER for cooling and heating operation rated in accordance with DOE requirements.
- **Low Operating Sound Level** - The upward air flow carries the normal operating noise up and away from the living area. The rigid top panel effectively isolates noise. Isolator mounted compressor and the rippled fins of the condenser coil muffle the normal fan motor and compressor operating sounds. The unique formed base pan also aids in sound attenuation with its structural design. Sound ratings as tested under AHRI test procedures shall be less than 77 dbA for all models.

UNIT CABINET

Unit cabinet shall be a single piece design, with drip edges and no-seam corners to provide optimum water integrity. Unit shall have a rigidly mounted condenser coil guard to provide protection from objects and personnel after installation. Indoor blower section shall be insulated with foil-faced or foam insulation, fastened to prevent insulation from entering the air stream. Cabinet panels shall be separate, easily removable for servicing and maintenance. Unit shall be built on a formed, design base pan, with embossments at critical points to add strength and rigidity and to aid in minimizing sound. Full perimeter base rails shall be provided to assure reliable transit of equipment, overhead rigging, for truck access and proper sealing on roof curb applications. Base rails shall be easily removable, when required to lower unit height. Filters shall be field installed, furnished and be accessible through a removable access door, sealed airtight. Units vertical discharge and return duct configuration shall be designed to fit between standard 24" O.C. beams without modification to building structure, duct work and base unit.

- **Durable Finish** - The cabinet shall be is made of G90 galvanized steel with a powder paint coating for appearance and protection. The pre-treated galvanized steel shall provide a better paint-to-steel bond, which resists corrosion and rust creep. Powder paint finish shall provide superior corrosion resistance (1000 hour salt spray tested).

- **On Site Flexibility** - All model sizes shall use a compact design cabinet in one of two footprints. This provides installer flexibility for placing the proper capacity unit on curbs or pads with the smallest footprint after the internal load has been determined. Field convertible duct connections from side shot to down shot allows the installer to have greater flexibility with less inventory.
- **Attractive Appearance** - A single-piece top cover containing a top-discharge condenser fan arrangement shall be used which requires less square footage on installation and provides a wider variety of installations. The one-piece design adds greater water integrity. Rounded corners with water drip edges add to the attractive appearance and prevent water penetration.
- **Convertible Airflow Design** - The bottom duct openings are covered when they leave the factory, ready to be used for a side supply/side return application. If a bottom supply/bottom return application is desired, simply remove the two panels from the bottom of the unit and place them in the side supply/side return duct openings. No panel cutting is required and no accessory panel is necessary. Convertible airflow design allows maximum field flexibility and minimum inventory.
- **Utility Connections Made Easy** - Electric utility access shall be provided through the bottom or the side of the unit. Utility connections should be made quickly and with a minimum amount of field labor. A field supplied and field installed electrical disconnect switch must be installed.
- **Easy Service Access** - Individual access panels are provided in access to all major components - compressors, indoor coils, blower, controls/electric heat kits, filters, etc. that makes servicing easy. Removing these panels allow easy removal of the components such as the blower assembly for maintenance and ease of troubleshooting.
- **Top Discharge** - The top-discharge outdoor fan does not disrupt neighboring areas or dry out vegetation surrounding the unit. The warm air from the top mounted fan is blown up and away from the structure and any landscaping.
- **Outdoor Coil Grille** - All models utilize a stamped slotted design which provides superior impact protection against small objects during transit and after installation.
- **Indoor Blower Assembly** - Fan shall be direct drive design. Fan wheel shall be double-inlet type with forward-curved blades, dynamically balanced to operate smoothly throughout the entire range of operation. Airflow design shall be constant air volume. Bearings shall be sealed and permanently lubricated for longer life and no maintenance. Fan assembly shall be a slide-out design for easy removal and cleaning. Indoor blower motors shall be equipped with a standard high efficiency brushless DC motor (constant torque) also known as a standard ECM motor.
- **Outdoor Fan Assembly** - The outdoor fan shall be of the direct-driven propeller type, discharge air vertically, have aluminum blades riveted to corrosion resistant steel spider bracket and shall be statically balanced for smooth operation. The outdoor fan motor shall be totally enclosed with permanently lubricated bearings and internally protected against overload conditions.

REFRIGERANT COMPONENTS

- **Protected Compressor** - The compressor shall be a fully hermetic type, direct drive compressor, that is internally protected against high pressure and temperature. This is accomplished by the simultaneous operation of high pressure relief valve and a temperature sensor which protect the compressor if undesirable operating conditions occur. The hermetic motor shall be suction gas cooled and have a voltage range of +/- 10% of the unit nameplate voltage. Compressors shall have internal isolation and sound muffling to minimize vibration and noise, and be externally isolated on a dedicated, independent mounting.
- **Indoor Coils** - Indoor coils shall be of the direct expansion, draw through design and have aluminum plate fins mechanically bonded to seamless internally enhanced tin-coated copper tubes with all joints brazed.
- **Condensate Pan** - A corrosion-resistant, long-lasting, water-tight pan is positioned below the indoor coil to collect and drain all condensate, preventing build-up of stagnant condensate. The condensate pan conforms to ASHRAE 62-89 standards (Ventilation for Acceptable Indoor Air Quality).
- **Condensate Drain** - The 3/4 inch NPT female connection is rigidly mounted to assure proper fit and leak tight seal.
- **Outdoor Coils** - Outdoor coils shall have aluminum plate fins mechanically bonded to seamless internally enhanced copper tubes with all joints brazed, and be a draw through design.

Refrigerant Circuit and Refrigerant Safety Components shall include: Thermal expansion devices (TXV's) shall be factory mounted and provided, Filter/strainer to eliminate any foreign matter, reversing valves to control refrigerant flow.

CONTROLS

- **Simple Control Circuit** - Field thermostat wiring connects to color coded leads using twist on wire connections. Cooling controls use contactor and relays for simple application and troubleshooting. Mate-n-lock plug connectors are used. The electrical control box is not located in the compressor compartment. The controls are mounted to allow the separate access panel to be removed for trouble shooting and maintenance without affecting the normal system operating pressures. All wiring internal to the unit is color/number coded.
- **Pressure Switches** - A high pressure switch is standard in all units. It is an automatic reset switch. When discharge pressure reaches 650 psi, the compressor will de-energize until pressure reaches 450 psi.
- **Factory Testing** - Installation time and costs are reduced by easy power and control wiring connections. All units are completely wired, charged with R-410A and tested prior to shipment. Test stations using a state-of-the-art computerized process system shall be used to insure product quality. Refrigerant charge and component part numbers are verified via computer bar code scans during assembly. Vital run test statistics such as system pressure, motor currents, air velocity and temperature, unit vibration, and gas system safeties are monitored and recorded by the system to insure unit performance. This data could be provided by serial number tracking if requested.
- **Electric Heat** - All electric heat models use 6HK electric heat, which are available in 460V/3/60 10kW to 25kW.

PHYSICAL DATA

NOMINAL TONNAGE	MODELS		
	PCE4A3641	PCE4B4841	PCE4B6041
	3.0	4.0	5.0
AHRI Cooling Performance			
Gross Capacity @ AHRI A point (MBH)	37.2	47.7	55.0
AHRI net capacity (MBH)	34.6	45.5	52.5
EER	11.0	11.0	11.0
SEER	14.0	14.0	14.0
Nominal CFM	1200	1600	2000
System power (KW)	3.2	4.2	4.8
Refrigerant type	R410A	R410A	R410A
Refrigerant charge (lb-oz)	8-3	14-4	14-2
Dimensions (inches)			
Length	51-1/4	51-1/4	51-1/4
Width	35-3/4	45-3/4	45-3/4
Height	47	53	55
Operating WT. (lbs.)	395	483	500
Compressors			
Type	Recip	Scroll	Scroll
Outdoor Coil Data			
Face area (Sq. Ft.)	15.1	23.8	25.9
Rows	2	2	2
Fins per inch	22	22	22
Tube diameter	3/8	3/8	3/8
Circuitry Type	Interlaced	Interlaced	Interlaced
Indoor Coil Data			
Face area (Sq. Ft.)	4.6	6.3	6.3
Rows	3	3	3
Fins per inch	16	16	16
Tube diameter	3/8	3/8	3/8
Circuitry Type	Interlaced	Interlaced	Interlaced
Refrigerant control	TXV	TXV	TXV
Outdoor Fan Data			
Fan diameter (Inch)	24	26	26
Type	Prop	Prop	Prop
Drive type	Direct	Direct	Direct
No. speeds	1	1	1
Motor HP each	1/4	1/3	1/3
RPM	850	850	850
Nominal total CFM	2400	3200	3200
Direct Drive Indoor Fan Data			
Fan Size (Inch)	11 x 10	11 x 10	11 x 10
Type	Centrifugal	Centrifugal	Centrifugal
Motor HP each	1/2	1	1
RPM	1200 Max	1200 Max	1200 Max
Frame size	48	48	48
Filters			
Filter Size	A	B	B
Quantity - Size	Field-supplied external filters must be sized so as not to exceed 300 FPM air velocity through disposable filters. All three phase models are shipped with an internal filter rack kit. Consult the instructions supplied with that kit for replacement filter sizes. Filter sizes: A=20x20, B=20x30.		

COOLING PERFORMANCE DATA - 3 TON																
PACKAGED UNIT MODEL NO.		PCE4A36 - 3 Ton AC/Elec. Respac.														
CONDENSER ENTERING AIR TEMPERATURE	ID CFM	1400					1200					1000				
		80	80	75	80	80	80	80	75	80	80	80	80	75	80	80
		57	62	62	67	72	57	62	62	67	72	57	62	62	67	72
55 / 45	T.C.	45.3	48.1	48.0	53.1	54.6	42.2	46.3	46.2	51.3	53.5	39.2	44.6	44.5	49.5	52.4
	S.C.	45.3	43.2	36.0	36.5	27.9	42.2	39.5	33.3	33.4	26.1	39.2	35.8	30.6	30.4	24.4
	K.W.	2.15	2.16	2.16	2.15	2.15	2.07	2.07	2.07	2.06	2.05	1.99	1.99	1.99	1.97	1.95
65 / 55	T.C.	42.0	43.7	43.8	48.6	52.4	39.4	42.5	42.4	47.1	51.0	36.8	41.2	41.0	45.6	49.5
	S.C.	42.0	40.3	34.1	34.5	26.6	39.4	36.9	31.3	31.5	24.9	36.8	33.5	28.6	28.5	23.1
	K.W.	2.39	2.41	2.40	2.41	2.40	2.30	2.31	2.31	2.32	2.31	2.20	2.22	2.22	2.22	2.21
75 / 63	T.C.	38.7	39.3	39.6	44.1	50.1	36.6	38.6	38.5	42.9	48.4	34.5	37.9	37.4	41.7	46.7
	S.C.	38.7	37.4	32.1	32.4	25.4	36.6	34.3	29.3	29.5	23.6	34.5	31.1	26.6	26.7	21.8
	K.W.	2.63	2.66	2.64	2.67	2.65	2.52	2.55	2.54	2.57	2.56	2.41	2.45	2.44	2.47	2.46
85 / 69	T.C.	35.3	35.4	35.5	39.4	45.0	33.6	34.8	34.8	38.7	43.8	31.9	34.2	34.0	38.0	42.7
	S.C.	35.3	34.4	30.0	30.1	23.6	33.6	32.0	27.5	27.5	21.9	31.9	29.5	25.0	25.0	20.2
	K.W.	2.87	2.90	2.88	2.93	2.93	2.75	2.79	2.77	2.83	2.83	2.64	2.68	2.67	2.72	2.73
95 / 75	T.C.	31.9	31.5	31.5	34.8	39.8	30.5	31.0	31.0	34.6	39.2	29.2	30.5	30.6	34.3	38.6
	S.C.	31.9	31.5	28.0	27.8	21.8	30.5	29.7	25.7	25.5	20.2	29.2	27.9	23.4	23.3	18.7
	K.W.	3.11	3.14	3.12	3.20	3.21	2.99	3.02	3.00	3.08	3.10	2.87	2.91	2.89	2.97	2.99
105 / 83	T.C.	26.5	26.8	26.3	29.0	33.7	26.0	26.5	26.2	29.1	33.5	25.5	26.3	26.0	29.2	33.4
	S.C.	26.5	26.8	24.0	24.4	19.3	26.0	25.7	22.6	22.8	18.0	25.5	24.5	21.2	21.3	16.7
	K.W.	3.43	3.39	3.35	3.43	3.48	3.27	3.27	3.23	3.32	3.37	3.11	3.14	3.11	3.20	3.25
115 / 89	T.C.	21.4	22.3	21.3	23.4	27.7	21.6	22.2	21.4	23.8	28.0	21.8	22.2	21.5	24.2	28.3
	S.C.	21.4	22.3	20.2	21.1	17.0	21.6	21.8	19.7	20.2	15.9	21.8	21.3	19.1	19.3	14.8
	K.W.	3.74	3.65	3.57	3.67	3.75	3.54	3.50	3.44	3.54	3.63	3.34	3.36	3.32	3.42	3.50
125 / 95	T.C.	16.2	17.7	16.3	17.7	21.7	17.2	17.9	16.7	18.5	22.5	18.2	18.0	17.0	19.2	23.2
	S.C.	16.2	17.7	16.3	17.7	14.6	17.2	17.9	16.7	17.6	13.8	18.2	18.0	17.0	17.4	13.0
	K.W.	4.05	3.90	3.79	3.90	4.01	3.81	3.74	3.66	3.77	3.88	3.57	3.58	3.53	3.65	3.76

COOLING PERFORMANCE DATA - 4 TON																
PACKAGED UNIT MODEL NO.		PCE4B48 - 4 Ton AC/Elec. Respac.														
CONDENSER ENTERING AIR TEMPERATURE	ID CFM	1800					1600					1400				
		80	80	75	80	80	80	80	75	80	80	80	80	75	80	80
		57	62	62	67	72	57	62	62	67	72	57	62	62	67	72
55 / 45	T.C.	58.1	61.5	60.2	66.8	70.0	55.6	59.5	58.7	65.1	70.0	53.1	57.5	57.2	63.4	69.9
	S.C.	57.1	53.6	44.4	44.1	33.9	54.5	49.9	42.1	41.9	33.5	51.9	46.3	39.7	39.6	33.0
	K.W.	2.21	2.21	2.20	2.23	2.25	2.20	2.21	2.20	2.23	2.24	2.18	2.20	2.19	2.22	2.23
65 / 55	T.C.	54.4	56.8	55.7	62.2	66.3	52.1	55.1	54.4	60.9	65.7	49.8	53.4	53.1	59.5	65.1
	S.C.	54.0	51.5	42.4	42.4	32.4	51.6	48.0	40.1	40.2	31.5	49.2	44.5	37.9	38.0	30.6
	K.W.	2.46	2.47	2.46	2.49	2.50	2.44	2.46	2.45	2.49	2.49	2.43	2.46	2.45	2.48	2.49
75 / 63	T.C.	50.8	52.2	51.2	57.6	62.5	48.7	50.7	50.1	56.6	61.4	46.5	49.3	49.0	55.6	60.3
	S.C.	50.8	49.5	40.4	40.6	30.9	48.7	46.0	38.2	38.5	29.5	46.5	42.6	36.0	36.3	28.2
	K.W.	2.71	2.73	2.72	2.75	2.76	2.69	2.72	2.71	2.75	2.75	2.68	2.71	2.70	2.74	2.74
85 / 69	T.C.	46.5	47.2	46.2	52.4	57.6	44.6	46.0	45.1	51.5	56.8	42.8	44.9	44.1	50.6	56.0
	S.C.	46.5	45.8	37.7	38.1	28.7	44.6	42.9	35.5	35.9	27.5	42.8	40.0	33.3	33.8	26.3
	K.W.	3.05	3.06	3.05	3.08	3.09	3.04	3.05	3.04	3.08	3.09	3.02	3.05	3.03	3.07	3.08
95 / 75	T.C.	42.2	42.2	41.2	47.2	52.7	40.6	41.3	40.2	46.4	52.2	39.0	40.5	39.2	45.5	51.7
	S.C.	42.2	42.2	35.0	35.6	26.5	40.6	39.8	32.9	33.4	25.4	39.0	37.4	30.7	31.2	24.3
	K.W.	3.39	3.38	3.38	3.41	3.42	3.38	3.38	3.38	3.41	3.42	3.36	3.38	3.37	3.40	3.42
105 / 83	T.C.	37.2	37.0	35.3	40.9	46.8	36.1	36.2	35.0	40.6	46.5	34.9	35.4	34.8	40.3	46.2
	S.C.	37.2	37.0	31.2	33.3	24.7	36.1	35.2	30.1	31.3	23.7	34.9	33.4	28.9	29.4	22.7
	K.W.	3.85	3.85	3.85	3.88	3.89	3.85	3.85	3.85	3.88	3.89	3.84	3.86	3.84	3.87	3.88
115 / 89	T.C.	32.4	31.9	29.6	34.9	41.1	31.7	31.2	30.1	35.1	41.0	30.9	30.5	30.6	35.3	41.0
	S.C.	32.4	31.9	27.5	31.0	23.0	31.7	30.7	27.3	29.3	22.0	30.9	29.5	27.1	27.6	21.0
	K.W.	4.31	4.31	4.30	4.33	4.35	4.30	4.31	4.30	4.33	4.34	4.30	4.31	4.30	4.33	4.34
125 / 95	T.C.	27.6	26.9	23.9	28.8	35.5	27.3	26.2	25.1	29.6	35.6	27.0	25.5	26.4	30.3	35.7
	S.C.	27.6	26.9	23.9	28.8	21.2	27.3	26.2	24.6	27.4	20.3	27.0	25.5	25.4	25.9	19.4
	K.W.	4.76	4.76	4.76	4.79	4.80	4.76	4.77	4.76	4.79	4.80	4.76	4.77	4.76	4.79	4.79

COOLING PERFORMANCE DATA - 5 TON																
PACKAGED UNIT MODEL NO.		PCE4B60 - 5.0 Ton AC/Elec Respac														
CONDENSER ENTERING AIR TEMPERATURE	ID CFM	2050					1800					1550				
		80	80	75	80	80	80	80	75	80	80	80	80	75	80	80
		IDWB	57	62	62	67	72	57	62	62	67	72	57	62	62	67
55 / 45	T.C.	63.1	65.4	65.2	68.7	72.9	60.4	64.1	64.4	68.0	71.8	57.6	62.7	63.6	67.2	70.6
	S.C.	63.1	58.0	49.1	46.2	34.9	60.4	54.7	46.3	44.2	33.9	57.6	51.4	43.4	42.2	32.8
	K.W.	3.44	3.44	3.43	3.43	3.41	3.28	3.29	3.33	3.34	3.32	3.12	3.14	3.23	3.24	3.23
65 / 55	T.C.	59.1	61.9	28.9	32.9	36.7	56.7	60.5	28.4	32.2	36.0	54.3	59.1	27.9	31.6	35.4
	S.C.	59.1	57.3	23.1	23.1	17.6	56.7	53.5	21.5	21.6	16.8	54.3	49.7	20.0	20.0	16.0
	K.W.	3.74	3.75	3.74	3.76	3.76	3.57	3.59	3.61	3.63	3.64	3.41	3.43	3.48	3.50	3.52
75 / 63	T.C.	55.1	58.3	57.7	65.7	73.2	53.0	56.9	56.7	64.4	72.0	51.0	55.5	55.7	63.1	70.7
	S.C.	55.1	56.5	46.1	46.2	35.2	53.0	52.3	43.0	43.1	33.6	51.0	48.1	40.0	40.0	32.0
	K.W.	4.03	4.05	4.05	4.09	4.11	3.87	3.88	3.89	3.92	3.96	3.70	3.72	3.73	3.76	3.80
85 / 69	T.C.	27.6	53.5	52.8	60.0	60.4	26.5	52.5	52.2	59.2	63.2	25.5	51.5	51.6	58.4	65.9
	S.C.	27.6	52.6	43.8	44.0	41.4	26.5	49.3	40.9	41.1	35.7	25.5	46.0	38.0	38.1	30.1
	K.W.	4.42	4.44	4.45	4.48	4.47	4.26	4.28	4.29	4.31	4.33	4.11	4.12	4.13	4.15	4.19
95 / 75	T.C.	47.5	48.7	47.9	54.3	47.5	46.0	48.1	47.8	54.0	54.3	44.4	47.5	47.6	53.6	61.1
	S.C.	47.5	48.7	41.5	41.8	47.5	46.0	46.3	38.8	39.0	37.9	44.4	43.9	36.1	36.3	28.2
	K.W.	4.80	4.84	4.84	4.86	4.83	4.66	4.68	4.69	4.71	4.70	4.51	4.52	4.53	4.55	4.57
105 / 83	T.C.	43.0	44.0	39.9	46.0	44.7	41.5	42.6	40.0	46.1	49.5	40.0	41.1	40.1	46.2	54.3
	S.C.	43.0	44.0	35.7	37.8	39.3	41.5	41.4	34.1	35.6	32.5	40.0	38.7	32.5	33.3	25.7
	K.W.	5.37	5.40	5.41	5.42	5.41	5.23	5.25	5.26	5.26	5.27	5.10	5.09	5.11	5.11	5.13
115 / 89	T.C.	38.6	39.6	32.1	38.0	42.0	37.1	37.2	32.5	38.5	44.8	35.6	34.9	32.9	39.0	47.6
	S.C.	38.6	39.6	30.0	33.9	31.3	37.1	36.6	29.5	32.2	27.4	35.6	33.7	29.1	30.5	23.4
	K.W.	5.92	5.96	5.97	5.96	5.98	5.79	5.80	5.82	5.81	5.83	5.66	5.64	5.67	5.66	5.67
125 / 95	T.C.	34.2	35.1	24.4	30.0	39.3	32.7	31.9	25.0	31.0	40.1	31.2	28.7	25.6	31.9	41.0
	S.C.	34.2	35.1	24.4	30.0	23.4	32.7	31.9	25.0	28.8	22.2	31.2	28.7	25.6	27.6	21.0
	K.W.	6.47	6.51	6.53	6.49	6.55	6.35	6.35	6.38	6.35	6.38	6.23	6.19	6.24	6.21	6.21

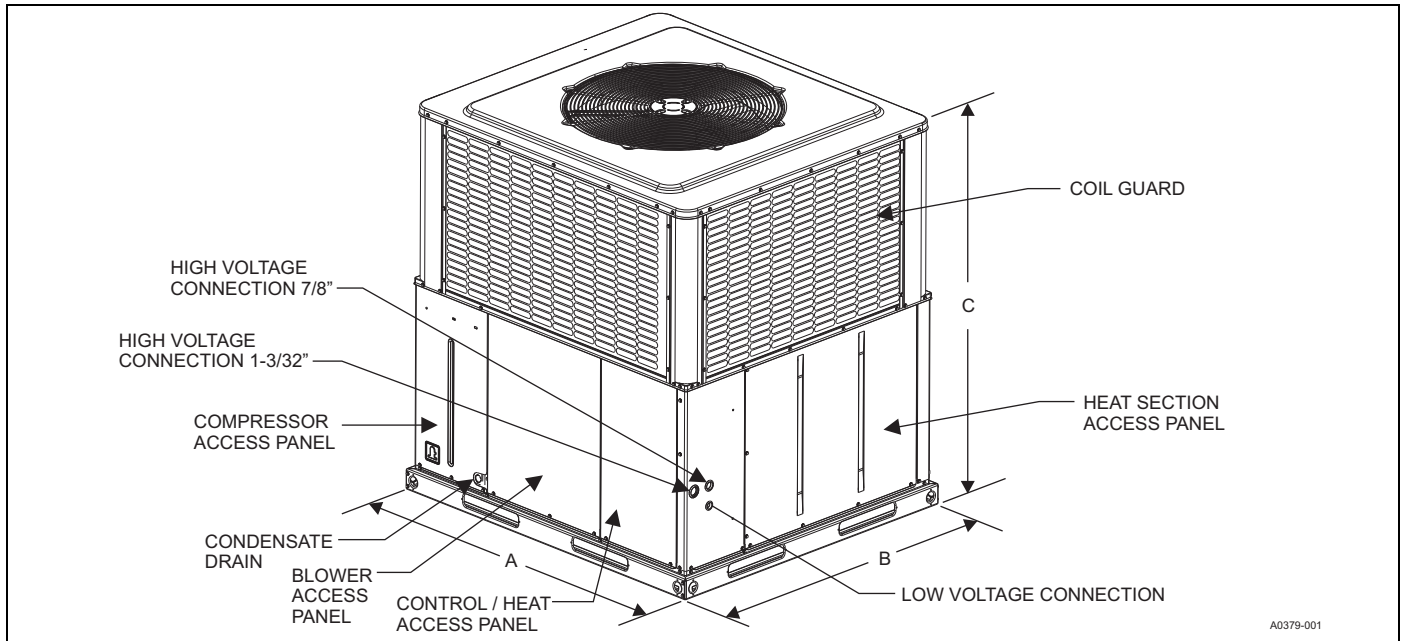

UNIT DIMENSIONS

Model	Dimensions		
	A	B	C
PCE4A3641	51-1/4	35-3/4	47
PCE4B4841		45-3/4	53
PCE4B6041		45-3/4	55

UNIT CLEARANCES

Direction	Distance (in.)	Direction	Distance (in.)
Top ¹	36	Right Side	36
Side Opposite Ducts	36	Left Side	24
Duct Panel	0	Bottom ^{2,3}	1

Note: For units applied with a roof curb, the minimum clearance may be reduced from 1 inch to 1/2 inch between combustible roof curb material and this supply air duct.

1. Minimum Clearance of 1inch all sides of supply air duct for the first 3 feet of duct for 20 & 25 kW., zero inches thereafter. For all other heaters, zero inch clearance all sides for entire length of duct.
2. Units must be installed outdoors. Overhanging structures or shrubs should not obscure outdoor air discharge outlet.
3. Units may be installed on combustible floors made from wood or class A, B or C roof covering materials.

ELECTRIC HEAT MINIMUM SUPPLY AIR

Model	Voltage	Minimum Blower Speed for Electric Heat								
		Heater kW								
		2	5	8	10	13	15	18	20	25
PCE4A3641	460-3-60	Low #1	Low #1	Low #1	Low #1	Med. Low #2	High #5	--	--	--
PCE4B4841		--	Low #1	Low #1	Low #1	Low #1	Low #1	Med. Low #2	Med. High #4	--
PCE4B6041		--	Low #1	Low #1	Low #1	Low #1	Low #1	Low #1	Low #1	Med. Low #2

INDOOR BLOWER SPECIFICATIONS

Model	Motor				
	HP	RPM	EFF.	SF	Frame
PCE4A3641	1/2	Variable	0.8	1.0	48
PCE4B4841	1				
PCE4B6041	1				

SOUND PERFORMANCE

Model (Tons)	Sound Rating ¹ dB (A)	Octave Band Centerline Frequency (Hz)						
		125	250	500	1000	2000	4000	8000
PCE4A3641	74	58.5	61.8	65.4	66.5	60.7	54.8	49.8
PCE4B4841	74	63.5	63.9	62.3	65.0	64.0	54.1	46.6
PCE4B6041	76	72.3	65.0	63.9	64.0	60.0	55.5	49.0

1. Rated in accordance with AHRI Standard 270.

ELECTRICAL DATA - 460-3-60 - SINGLE SOURCE POWER

Model	Compressor			OD Fan Motor FLA	Blower Motor FLA	Electric Heat Option				MCA ¹ (Total Unit)	Max Fuse ² or Breaker Size ³ (Total Unit)	MCA ¹ (Unit Minus Heater)	Max Fuse ² or Breaker Size ³ (Unit Minus Heater)	MCA ¹ Unit (Heater Only)	Max Fuse ² or Breaker Size ³ (Unit Minus Heater)
	RLA	LRA	MCC			Heater Kit	Heater kW	Stages	Heater Amps						
PCE4A36	4.1	34.0	7.6	0.70	1.95	none	--	--	--	7.8	15	7.8	15	-	-
						6HK06501046	8.8	1	11.0	15.8	20	7.8	15	13.8	15
						6HK06501546	13.2	1	16.6	22.7	25	7.8	15	20.7	25
PCE4B48	6.2	41.0	9.7	0.87	3.15	none	--	--	--	11.8	15	11.8	15	-	-
						6HK06501046	8.8	1	11.0	17.0	20	11.8	15	13.8	15
						6HK06501546	13.2	1	16.6	23.9	25	11.8	15	20.7	25
						6HK06501846	15.9	1	20.0	28.1	30	11.8	15	25.0	25
						6HK06502046	17.6	1	22.1	30.8	35	11.8	15	27.6	30
PCE4B60	7.8	52.0	12.1	0.87	3.15	none	--	--	--	13.8	20	13.8	20	-	-
						6HK06501046	8.8	1	11.0	17.0	20	13.8	20	13.8	15
						6HK06501546	13.2	1	16.6	23.9	25	13.8	20	20.7	25
						6HK06501846	15.9	1	20.0	28.1	30	13.8	20	25.0	25
						6HK06502046	17.6	1	22.1	30.8	35	13.8	20	27.6	30
						6HK06502546	22.0	1	27.6	37.7	40	13.8	20	34.5	35

NOTE - Single-source power MCA and MOP requirements are given here for reference if the unit is to be installed with a field-installed single-point power modification.

1. Minimum Circuit Ampacity.

2. Maximum Over Current Protection per standard UL 1995.

3. Fuse or HACR circuit breaker size to be field installed.

Electrical Data for 460-3-60 Multi Source Power

Model	Compressor			OD Fan Motor	Blower Motor	Electric Heat Option				MCA Amps	Max Fuse or Breaker Size	MCA Amps	Max Fuse or Breaker Size
	RLA	LRA	MCC			FLA	FLA	Heater Kit	Heater kW				
					CIRCUIT #1 Unit Minus Heaters		CIRCUIT #2 Heaters						
PCE4A36	4.1	34.0	7.6	0.7	1.95	none	--	--	--	7.8	15	--	--
						6HK06501046	8.8	1	11.0	7.8	15	13.8	15
						6HK06501546	13.2	1	16.6	7.8	15	20.7	25
PCE4B48	6.2	41.0	9.7	0.87	3.15	none	--	--	--	11.8	15	--	--
						6HK06501046	8.8	1	11.0	11.8	15	13.8	15
						6HK06501546	13.2	1	16.6	11.8	15	20.7	25
						6HK06501846	15.9	1	20.0	11.8	15	25.0	25
						6HK06502046	17.6	1	22.1	11.8	15	27.6	30
PCE4B60	7.8	52.0	12.1	0.87	3.15	none	--	--	--	13.8	20	--	--
						6HK06501046	8.8	1	11.0	13.8	20	13.8	15
						6HK06501546	13.2	1	16.6	13.8	20	20.7	25
						6HK06501846	15.9	1	20.0	13.8	20	25.0	25
						6HK06502046	17.6	1	22.1	13.8	20	27.6	30
						6HK06502546	22.0	1	27.6	13.8	20	34.5	35

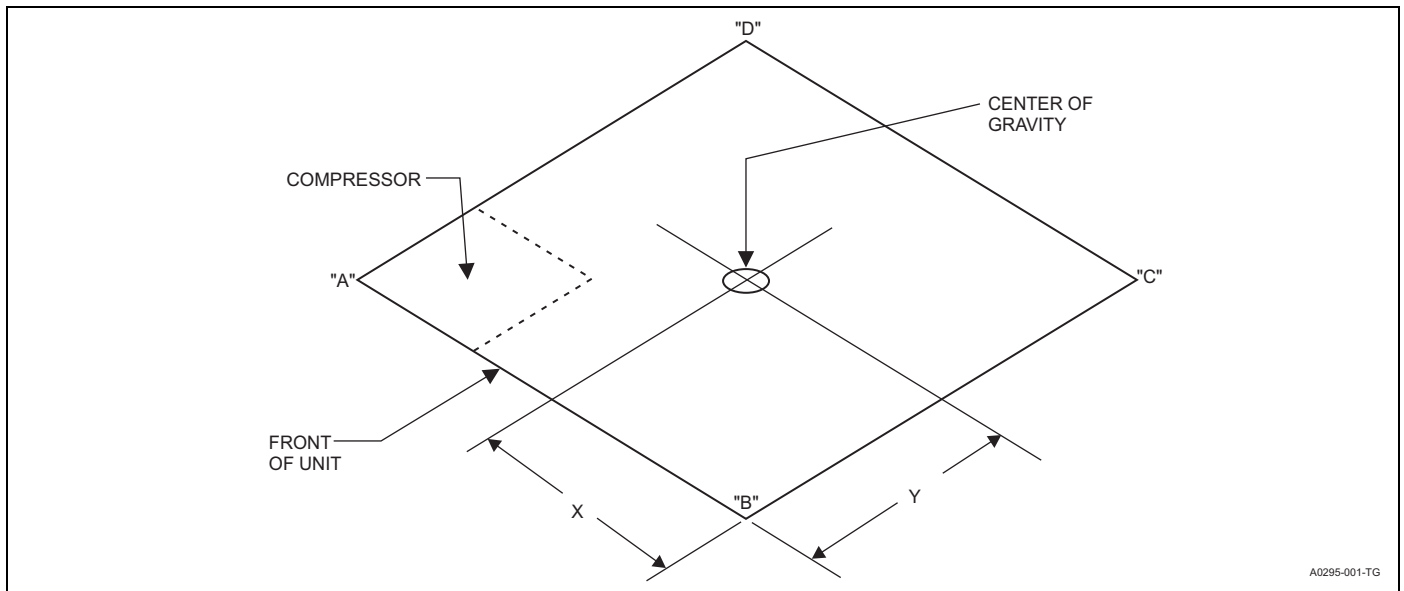

WEIGHTS AND DIMENSIONS

Model	Weight (lbs.)		Center of Gravity		4 Point Load Location (lbs.)			
	Shipping	Operating	X	Y	A	B	C	D
PCE4A3641	400	395	30	15	112	123	120	45
PCE4B4841	488	483		19	158	125	130	75
PCE4B6041	505	500		20	157	134	140	74

AIRFLOW PERFORMANCE - Side Duct Application

Model	Motor Speed	External Static Pressure (Inches WC)							
		0.1	0.2	0.3	0.4	0.5	0.6	0.7	0.8
		SCFM	SCFM	SCFM	SCFM	SCFM	SCFM	SCFM	SCFM
PCE4A3641	Low (1)	1225	1174	1131	1090	1046	993	941	888
	Low/Medium (2)	1259	1209	1166	1126	1084	1032	980	928
	Medium (3)	1314	1271	1229	1186	1144	1097	1049	998
	Medium/High (4)	1348	1306	1259	1222	1179	1133	1086	1036
	High (5)	1506	1471	1403	1389	1345	1305	1262	1216
PCE4B4841	Low (1)	1620	1564	1517	1466	1418	1360	1308	1206
	Low/Medium (2)	1694	1630	1580	1530	1482	1430	1380	1292
	Medium (3)	1798	1722	1669	1620	1572	1527	1480	1413
	Medium/High (4)	1835	1758	1703	1653	1604	1558	1511	1442
	High (5)	2146	2085	2025	1960	1872	1862	1798	1735
PCE4B6041	Low (1)	1730	1682	1628	1592	1552	1517	1479	1439
	Low/Medium (2)	1858	1807	1749	1710	1667	1629	1589	1546
	Medium (3)	2054	1998	1934	1890	1843	1801	1757	1710
	Medium/High (4)	2195	2144	2098	2049	2003	1955	1883	1868
	High (5)	2445	2388	2306	2293	2235	2178	2129	2077

1. Airflow tested with dry coil conditions, without air filters, at 460 volts.
2. Applications above 0.8" w.c. external static pressure are not recommended.
3. Brushless DC high efficiency standard ECM blower motor used for all indoor blower assemblies.
4. Heating applications tested at 0.50" w.c. esp, and cooling applications tested at 0.30" w.c. esp per standards.

AIRFLOW PERFORMANCE - Bottom Duct Application

Model	Motor Speed	External Static Pressure (Inches WC)							
		0.1	0.2	0.3	0.4	0.5	0.6	0.7	0.8
		SCFM	SCFM	SCFM	SCFM	SCFM	SCFM	SCFM	SCFM
PCE4A3641	Low (1)	1231	1186	1146	1103	1069	1030	977	912
	Low/Medium (2)	1270	1225	1189	1140	1098	1046	1008	960
	Medium (3)	1317	1286	1245	1198	1151	1110	1064	1024
	Medium/High (4)	1358	1317	1275	1238	1197	1148	1105	1057
	High (5)	1517	1475	1447	1400	1357	1318	1275	1232
PCE4B4841	Low (1)	1598	1548	1502	1454	1410	1362	1307	1251
	Low/Medium (2)	1663	1612	1568	1522	1476	1422	1370	1297
	Medium (3)	1789	1733	1670	1650	1596	1578	1535	1483
	Medium/High (4)	1931	1814	1808	1736	1673	1650	1597	1519
	High (5)	2131	2058	1998	1949	1892	1840	1788	1728
PCE4B6041	Low (1)	1655	1612	1596	1531	1461	1462	1429	1391
	Low/Medium (2)	1766	1720	1667	1629	1632	1539	1537	1498
	Medium (3)	1987	1933	1861	1817	1820	1715	1725	1651
	Medium/High (4)	2114	2050	2047	1974	1899	1889	1920	1866
	High (5)	2369	2308	2249	2183	2126	2088	2034	1990

1. Airflow tested with dry coil conditions, without air filters, at 460 volts
2. Applications above 0.8" w.c. external static pressure are not recommended.
3. Brushless DC high efficiency standard ECM blower motor used for all indoor blower assemblies.
4. Heating applications tested at 0.50" w.c. esp, and cooling applications tested at 0.30" w.c. esp per standards.

ADDITIONAL STATIC RESISTANCE

Size (Tons)	CFM	Wet Indoor Coil	Economizer ¹	Filter/Frame Kit
36 (3.0)	700	0.01	0.00	0.04
	800	0.02	0.01	0.06
	900	0.03	0.01	0.08
	1000	0.04	0.01	0.10
	1100	0.05	0.01	0.13
	1200	0.06	0.02	0.16
	1300	0.07	0.03	0.17
48 (4.0)	1400	0.08	0.04	0.18
	1100	0.02	0.02	0.04
	1200	0.03	0.02	0.04
	1300	0.04	0.02	0.05
	1400	0.05	0.03	0.05
	1500	0.06	0.04	0.06
	1600	0.07	0.04	0.07
	1700	0.07	0.04	0.08
	1800	0.08	0.04	0.09
60 (5.0)	1900	0.09	0.05	0.10
	2000	0.09	0.05	0.11
	1100	0.02	0.02	0.04
	1200	0.03	0.02	0.04
	1300	0.04	0.02	0.05
	1400	0.05	0.03	0.05
	1500	0.06	0.04	0.06
	1600	0.07	0.04	0.07
	1700	0.07	0.04	0.08
	1800	0.08	0.04	0.09
	1900	0.09	0.05	0.10
	2000	0.09	0.05	0.11

NOTE: Filter pressure drop based on standard filter media tested at velocities not to exceed 300 ft/min.

- The pressure drop through the economizer is greater for 100% outdoor air than for 100% return air. If the resistance of the return air duct is less than 0.25 IWG, the unit will deliver less CFM during full economizer operation.

DUCT DIMENSIONS (Inches) - Bottom View Looking Up

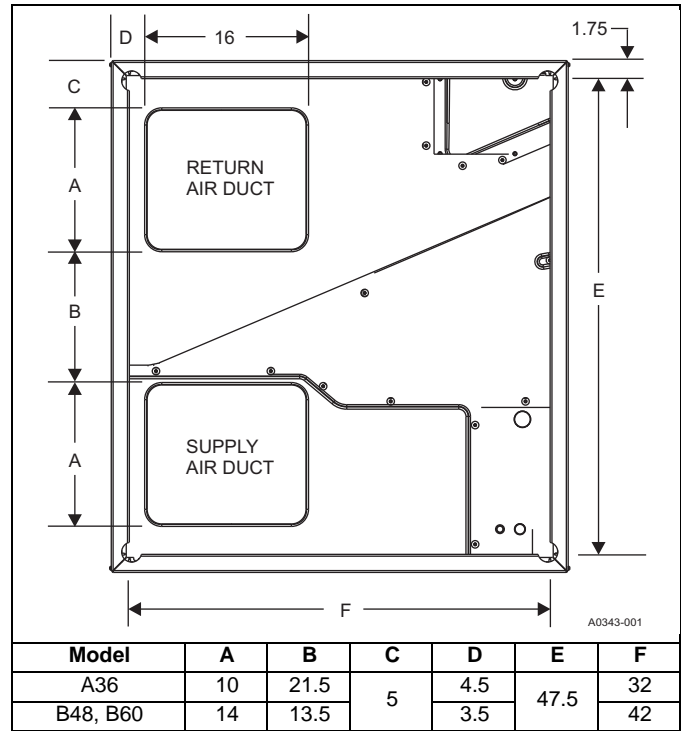

DUCT DIMENSIONS (Inches) - Rear View

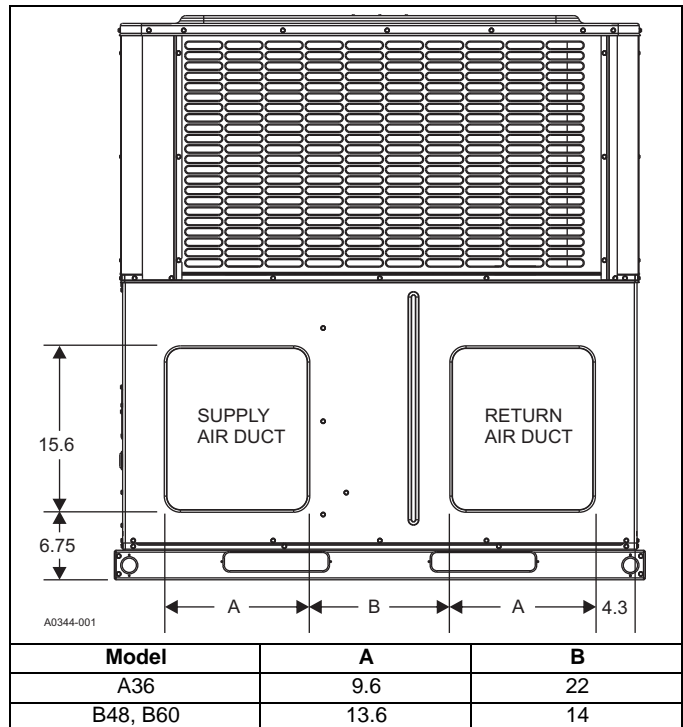

UNIT TYPICAL DUCT APPLICATIONS

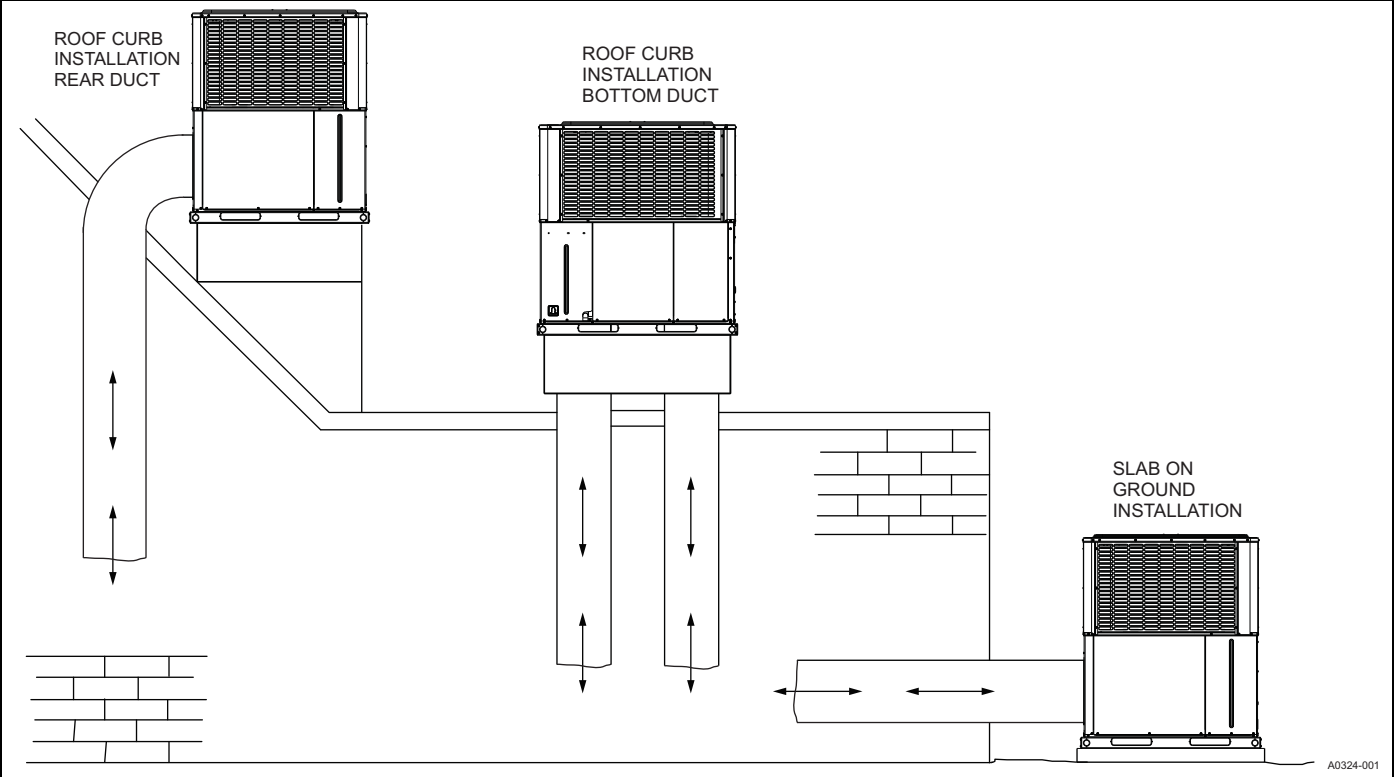

UNIT TYPICAL SLAB ON GROUND INSTALLATION

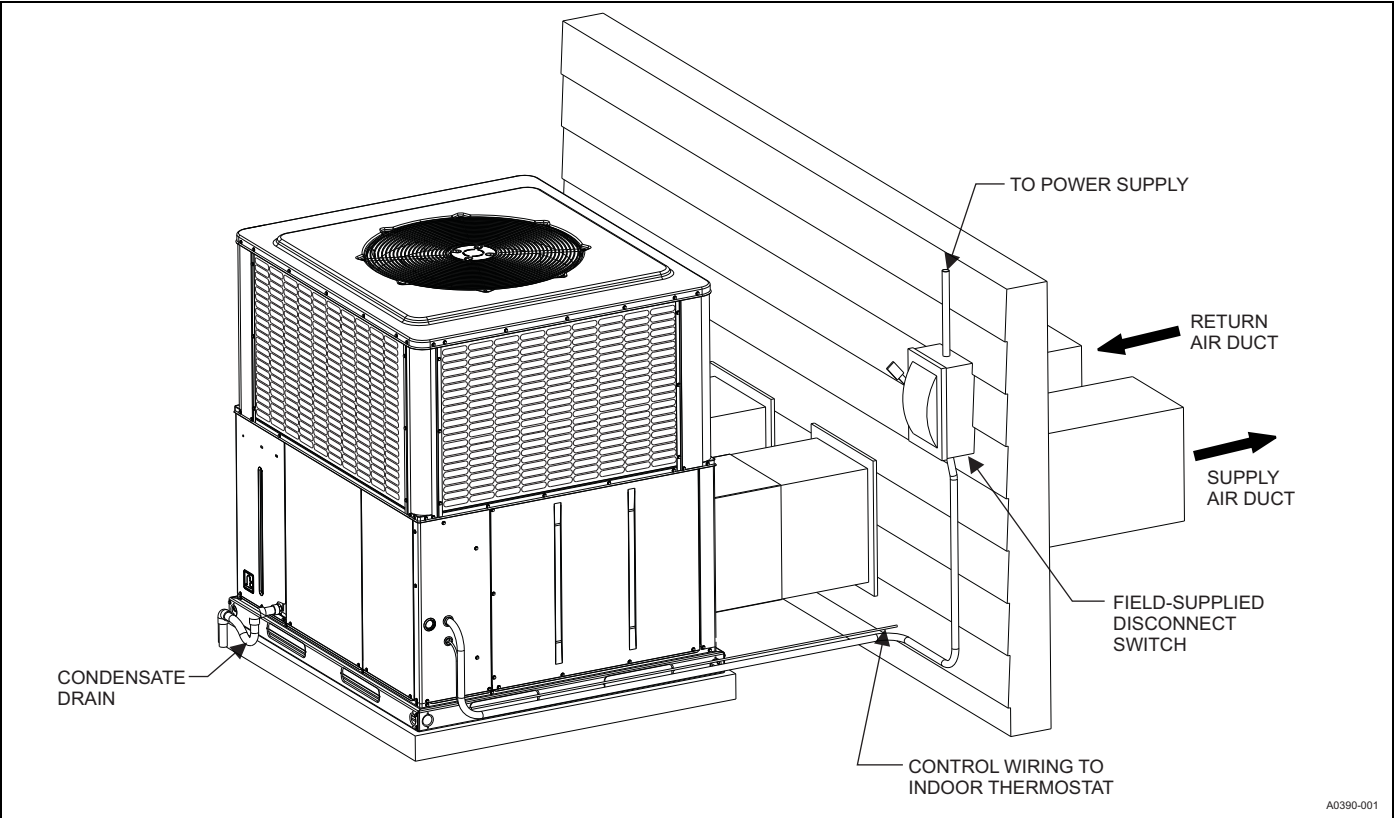

UNIT TYPICAL ROOF CURB INSTALLATION

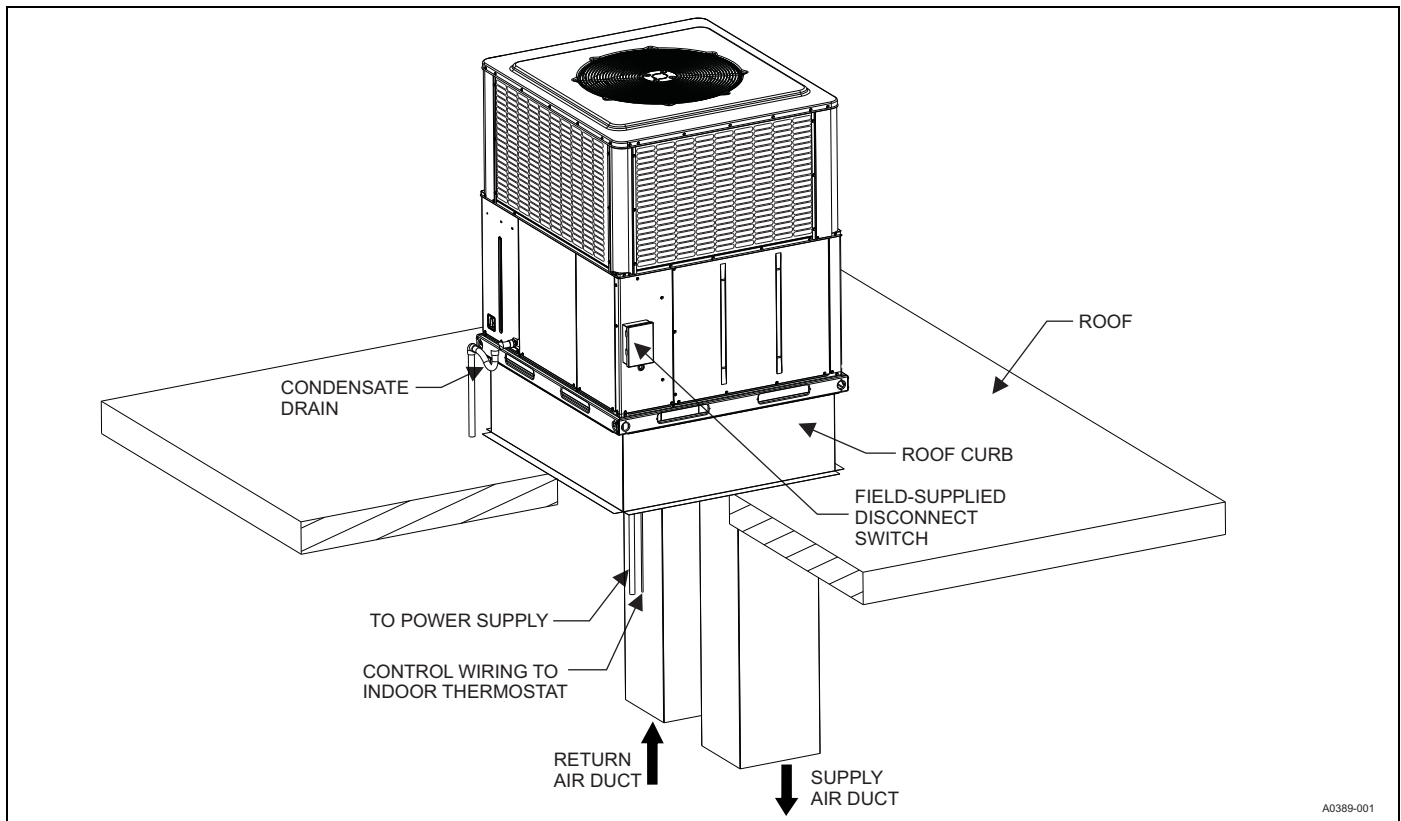

EXTERNAL STATIC PRESSURE SETUP

To measure external static pressure:

- Measure the supply air static pressure
- Record this positive number
- Measure the return air static pressure
- Record this negative number
- Treat the negative number as a positive and add the two numbers together
- This is total system static

