

Up to 14.5 SEER, 12 EER, 8.0 HSPF, PACKAGE HEAT PUMP, 2 to 5 TONS 208/230-1-60 Single Phase 2-5 Nominal Tons (Sizes 24-60) 208/230-3-60 & 460-3-60 Three Phase, 3-5 Nominal Tons (Sizes 36-60)

REFRIGERATION CIRCUIT

- Environmentally sound R-410A refrigerant
- Copper tube/aluminum fin condenser and evaporator coils
- Scroll compressor standard on all models
- Short-cycling protection for the compressor is built into the defrost control board
- Dehumidification mode (airflow reduction) on all models

EASY TO INSTALL AND SERVICE

- Installs easily on a rooftop or at ground level
- Easy three-panel accessibility for maintenance and installation
- Easily converts to down discharge applications
- Combination electric heating and cooling

BUILT TO LAST

- Direct drive high efficiency ECM blower motor on all models
- Pre-painted steel cabinet
- Vertical condenser fan discharge
- Full perimeter steel base rails
- High and low pressure switches provide added reliability for the compressor
- Hail guard (3/8" spacing) wire grilles standard on single phase models with optional factory installed tin-coated copper evaporator coil (TP). All other models have 2" spacing wire grilles including 3-phase models.
- Single and 3-phase models with factory installed option for low cabinet air leakage and tin-coated copper evaporator main tubes PGS4 (LC)
(Models with factory installed options are identified with letters in the 11th and 12th positions in the model number)

LIMITED WARRANTY*

- 1 Phase PHD4 "F" Models
- 3 year No Hassle Replacement™ limited warranty for tin-coated 'TP' models
 - 10 year parts limited warranty (including compressor and coils) with timely registration
 - 5 year parts limited warranty if not registered within 90 days of original installation
- 3 Phase PHD4 "F" Models
- 5 year compressor limited warranty
 - 1 year parts limited warranty
- * See warranty certificate for details and restrictions



Use of the AHR Certified TM Mark indicates a manufacturer's participation in the program. For verification of certification for individual products, go to www.ahrirectory.org.

UNIT PERFORMANCE DATA

Model Number	COOLING			HEATING		Unit Dimensions Height x Width x Depth in (mm)	Operating Weight lbs (kg)
	Capacity BTU/h	SEER	EER	Capacity BTU/h	HSPF		
208/230-1-60							
PHD424000K†0F	23,000	14.5	12.0	22,600	8.0	47 ³ / ₄ x 48 ³ / ₁₆ x 32 ⁵ / ₈ (1213 x 1224 x 829)	311 (141)
PHD430000K†0F	28,600	14.0	11.5	28,400	8.0	51 ³ / ₄ x 48 ³ / ₁₆ x 32 ⁵ / ₈ (1315 x 1224 x 829)	351 (159)
PHD436000K†0F	34,200	14.0	11.5	34,400	8.0	48 ³ / ₄ x 48 ³ / ₁₆ x 44 ³ / ₁₆ (1238 x 1224 x 1122)	387 (176)
PHD442000K†0F	41,000	14.0	11.5	40,000	8.0	54 ³ / ₄ x 48 ³ / ₁₆ x 44 ³ / ₁₆ (1391 x 1224 x 1122)	435 (197)
PHD448000K†0F	48,000	14.0	12.0	46,000	8.0	54 ³ / ₄ x 48 ³ / ₁₆ x 44 ³ / ₁₆ (1391 x 1224 x 1122)	456 (207)
PHD460000K†0F	57,500	14.0	11.5	57,500	8.0	48 ³ / ₄ x 48 ³ / ₁₆ x 44 ³ / ₁₆ (1238 x 1224 x 1122)	487 (221)
208/230-3-60							
PHD436000‡0F	34,200	14.0	11.5	34,400	8.0	48 ³ / ₄ x 48 ³ / ₁₆ x 44 ³ / ₁₆ (1238 x 1224 x 1122)	387 (176)
PHD442000‡0F	41,000	14.0	11.5	40,000	8.0	54 ³ / ₄ x 48 ³ / ₁₆ x 44 ³ / ₁₆ (1391 x 1224 x 1122)	435 (197)
PHD448000‡0F	48,000	14.0	12.0	46,000	8.0	54 ³ / ₄ x 48 ³ / ₁₆ x 44 ³ / ₁₆ (1391 x 1224 x 1122)	456 (207)
PHD460000‡0F	57,500	14.0	11.5	57,500	8.0	48 ³ / ₄ x 48 ³ / ₁₆ x 44 ³ / ₁₆ (1238 x 1224 x 1122)	487 (221)
460-3-60							
PHD436000L^0F	34,200	14.0	11.5	34,400	8.0	48 ³ / ₄ x 48 ³ / ₁₆ x 44 ³ / ₁₆ (1238 x 1224 x 1122)	387 (176)
PHD442000L^0F	41,000	14.0	11.5	40,000	8.0	54 ³ / ₄ x 48 ³ / ₁₆ x 44 ³ / ₁₆ (1391 x 1224 x 1122)	435 (197)
PHD448000L^0F	48,000	14.0	12.0	46,000	8.0	54 ³ / ₄ x 48 ³ / ₁₆ x 44 ³ / ₁₆ (1391 x 1224 x 1122)	456 (207)
PHD460000L^0F	57,500	14.0	11.5	57,500	8.0	48 ³ / ₄ x 48 ³ / ₁₆ x 44 ³ / ₁₆ (1238 x 1224 x 1122)	487 (221)

‡ K = 208/230-1-60, H = 208/230-3-60, L = 460-3-60

† 00 = No Options (All sizes), TP = Tin Plated Evaporator Main Tubes (24-60 sizes), LC = Low Cabinet Air Leakage plus Tin Coated Copper Evaporator Main Tubes (30-60 sizes)

^ 00 = No Options (36-60 sizes), LC = Low Cabinet Air Leakage plus Tin Coated Copper Evaporator Main Tubes

MODEL NUMBER NOMENCLATURE

MODEL NOMENCLATURE											
MODEL SERIES	1	2	3	4	5,6	7,8,9	10	11,12	13	14	15
	P	H	D	4	36	000	K	00	0	F	1
P = Package H = Heat Pump D = Standard 3 = 13 4 = 14 5 = 15 24 = 24,000 BTUH = 2 Tons 30 = 30,000 BTUH = 2.5 Tons 36 = 36,000 BTUH = 3 Tons 42 = 42,000 BTUH = 3.5 Tons 48 = 48,000 BTUH = 4 Tons 60 = 60,000 BTUH = 5 Tons TIER SEER NOMINAL COOLING CAPACITY NOMINAL HEATING BTUH (input) K = 208/230-1-60 H = 208/230-3-60 L = 460-3-60 VOLTAGE 00 = No options TP = Tin Plated Evaporator Main Tubes LC = Low Cabinet Air Leakage plus Tin Coated Copper Evap Main Tubes FACTORY INSTALLED OPTIONS 0 = Standard FEATURE CODE Sales Model Digit Engineering Digit											

AHRI* CAPACITIES

COOLING CAPACITIES AND EFFICIENCIES

UNIT	NOMINAL TONS	STANDARD CFM	COOLING CAPACITY	EER	SEER
24	2	800	23000	12.0	14.5
30	2.5	1000	28600	11.5	14.0
36	3	1200	34200	11.5	14.0
42	3.5	1400	41000	11.5	14.0
48	4	1600	48000	12.0	14.0
60	5	1750	57500	11.5	14.0

HEAT PUMP HEATING CAPACITIES AND EFFICIENCIES

UNIT	HEATING CAPACITY (BTUH) @ 47°F (8.3°C)	COP @ 47°F (8.3°C)	HEATING CAPACITY (BTUH) @ 17°F (-8.3°C)	COP @ 17°F (-8.3°C)	HSPF
24	22600	3.7	12000	2.30	8.0
30	28400	3.7	15600	2.35	8.0
36	34400	3.6	18600	2.30	8.0
42	40000	3.6	22600	2.40	8.0
48	46000	3.6	25800	2.40	8.0
60	57500	3.7	33000	2.45	8.0

LEGEND

dB—Sound Levels (decibels)

db—Dry Bulb

SEER—Seasonal Energy Efficiency Ratio

wb—Wet Bulb

COP—Coefficient of Performance

HSPF—Heating Season Performance Factor

* Air Conditioning, Heating & Refrigeration Institute.

**At "A" conditions—80°F (26.7°C) indoor db/67°F (19.4°C) indoor wb & 95°F (35°C) outdoor db.

† Rated in accordance with U.S. Government DOE Department of Energy) test procedures and/or AHRI Standards 210/240.

Notes:

1. Ratings are net values, reflecting the effects of circulating fan heat.

Ratings are based on:

Cooling Standard: 80°F (26.7°C) db, 67°F (19.4°C) wb indoor entering—air temperature and 95°F (35°C) db outdoor entering—air temperature.

2. Before purchasing this appliance, read important energy cost and efficiency information available from your retailer.

PHYSICAL DATA

	24	30	36	42	48	60
Unit Size	2	2.5	3	3.5	4	5
Shipping Weight (lb)	365	395	440	475	500	515
(kg)	166	179	200	215	227	234
Compressor Quantity	1					
Type	Scroll					
Refrigerant	R-410A					
Refrigerant Quantity (lb)	7.5	9.0	8.9	11.2	9.9	11.9
Quantity (kg)	3.4	4.1	4.0	5.1	4.5	5.4
Refrigerant Metering Device	Indoor TXV, Outdoor Dual Accuraters				Indoor Ac-curator, Outdoor Dual Accuraters	Indoor TXV, Outdoor Dual Accuraters
Orifice ID (in)	N/A				0.080 (1)	N/A
(mm)					2.03 (1)	
Orifice OD (in)	0.032 (2)	0.035 (2)	0.040 (2)	0.046 (2)	0.046 (2)	0.052 (2)
(mm)	0.81 (2)	0.89 (2)	1.02 (2)	1.17 (2)	1.17 (2)	1.32 (2)
Outdoor Coil Rows...Fins/in, face area (sq. ft.)	1...21 15.4	1...21 18.8	1...21 17.5	1...21 23.3	1...21 23.3	2...21 17.5
Outdoor Fan Nominal Airflow (cfm)	2500	3000	3600	4000	4000	3800
Diameter (in.)	24	24	26	26	26	26
Diameter (mm)	610	610	660	660	660	660
Motor hp (rpm)	1/12 (810)	1/10 (810)	1/5 (810)	1/5 (810)	1/5 (810)	1/4 (810)
Indoor Coil Rows...Fins/in, face area (sq. ft.)	3...17 3.7	3...17 3.7	2...15 5.6	3...17 4.7	3...17 4.7	3...17 5.6
Indoor Blower Nominal Airflow (cfm)	800	1000	1200	1350	1600	1750
Size (in.)	10 x 10	10 x 10	11 x 10	11 x 10	11 x 10	11 x 10
Size (mm)	254 x 254	254 x 254	279 x 254	279 x 254	279 x 254	279 x 254
Motor hp (rpm)	1/2	1/2	1/2	1/2	1	1
High Pressure Switch (psig) Cutout	650 +/- 15					
Reset (Auto)	420 +/- 25					
Loss-of-Charge/Low Pressure Switch (psig) Cutout	20 +/- 5					
Reset (Auto)	45 +/- 10					
Return Air Filters disposable	2 each 20x12x1 in. 508x305x25 mm		1 each 24x16x1 in. 610x406x25 mm 24x18x1 in. 610x457x25 mm	1 each 24x14x1 in. 610x356x25 mm 24x16x1 in. 610x406x25 mm	1 each 24x16x1 in. 610x406x25 mm 24x18x1 in. 610x457x25 mm	

*Required filter sizes shown are based on the larger of the AHRI (Air Conditioning Heating and Refrigeration Institute) rated cooling airflow or the heating airflow velocity of 300–350 ft/minute for throwaway type or 450 ft/minute for high–capacity type. Air filter pressure drop for non–standard filters must not exceed 0.08 IN. W.C.

† If using accessory filter rack refer to the filter rack installation instructions for correct filter size and quantity.

A-WEIGHTED SOUND POWER LEVEL (dBA)

UNIT SIZE	STANDARD RATING (dBA)	TYPICAL OCTAVE BAND SPECTRUM (dBA without tone adjustment)						
		125	250	500	1000	2000	4000	8000
24	74	55.1	54.3	56.7	54.9	51.7	47.2	42.9
30	75	52.7	53.0	57.9	58.7	54.8	52.2	43.2
36	74	61.9	63.3	58.9	59.9	58.7	56.2	52.4
42	73	52.7	56.9	61.5	60.7	56.7	54.1	47.9
48	74	57.4	57.1	60.9	63.2	57.8	54.8	46.1
60	75	59.3	62.2	62.1	64.1	59.4	55.8	50.2

NOTE: Tested in accordance with AHRI Standard 270–1995 (not listed in AHRI).

OPTIONS AND ACCESSORIES

ITEM	DESCRIPTION	FACTORY INSTALLED OPTION	FIELD INSTALLED ACCESSORY
Compressor Start Kit	Compressor Start Kit assists compressor start-up by providing additional starting torque on single phase units only.		X
Corporate Thermostats	Thermostats provide control for the system heating and cooling functions.		X
Crankcase Heater	Crankcase Heater provides anti-floodback protection for low-load cooling applications.		X*
Economizer	Horizontal Economizer with solid state controls and barometric relief dampers includes filter racks and provide outdoor air during cooling and reduce compressor operation.		X
	Vertical Economizer with solid state controls and barometric relief dampers includes filter racks and provide outdoor air during cooling and reduce compressor operation.		X
Electric Heaters	Electric Heat Supplement		X
Filter Rack	Filter Rack features easy installation, serviceability, and high-filtering performance for vertical applications. Includes 1-in. filter.		X
Flat Roof Curbs	Flat Roof Curbs in both 11-in (279 mm) and 14-in. (356 mm) sizes are available for roof mounted applications.		X
Low Ambient Kit	Low Ambient Kit (Motormaster II Control) allows the use of mechanical cooling down to outdoor temperatures as low as 0°F (-18°C) when properly installed.		X
Manual Outside Air Damper	Manual Outside Air Damper includes hood and filter rack with adjustable damper blade for up to 25% outdoor air.		X
Square-to-Round Duct Transition Kit	Square-to-Round Duct Transition Kit enable 24-48 size units to be fitted to 14 in. (356 mm) round ductwork.		X
Curb Adaptor	Adapter curb for new unit with base rail installed on existing curb		X
Gasket Kit	For field modified existing roof curb with new base rail unit.		X
Cabinet leakage	Cabinet air leakage less than 2.0% at 1.0 inch W.C. and cabinet air leakage less than 1.4% at 0.5 inch W.C., when tested in accordance with ASHRAE standard 193.	X	
Outdoor Coil Dense Metal Wire Grille	3/8" spacing Dense Metal Wire Grille provide hail and vandalism protection. (Factory installed on single phase with 'TP' and 'LC')	X	X
Dual Point Electric Heaters	Allows you to power the electric heater and unit contactor separately by having two individual field power supply circuits connected respectively.		X

Electric Heaters

ORDERING NO.	NOMINAL CAPACITY (kW @ 240 or 480 VOLTS)	USED WITH SIZES					
		24	30	36	42	48	60
208/230 – SINGLE PHASE – 60 HZ							
CPHEATER052A0*	5.0	X	X	X			
CPHEATER064A0*	5.0	X	X	X	X	X	X
CPHEATER069A0*	7.2	X					
CPHEATER070A0*	7.2	X	X	X	X	X	X
CPHEATER050A0*	10.0	X	X	X	X	X	X
CPHEATER066A0*	15.0		X	X	X	X	X
CPHEATER054A0*	20.0				X	X	X
208/230 – THREE PHASE – 60 HZ							
CPHEATER055A0*	5.0			X	X	X	X
CPHEATER056A0*	10.0			X	X		
CPHEATER068A0*	10.0			X	X	X	X
CPHEATER058A0*	15.0			X	X	X	X
CPHEATER059A0*	20.0				X	X	X
460 – THREE PHASE – 60 HZ							
CPHEATER061A0*	10.0			X	X	X	X
CPHEATER062A0*	15.0			X	X	X	X
CPHEATER063A0*	20.0				X	X	X

NOTE: Electric heaters are rated at 240v. Refer to Multiplication Factors table for other voltages.

X = Approved combination

Minimum Airflow for Reliable Electric Heater Operation (CFM)

SIZE	24	30	36	42	48	60
AIRFLOW (CFM)	800	1025	1250	1400	1710	1800

ECONOMIZER

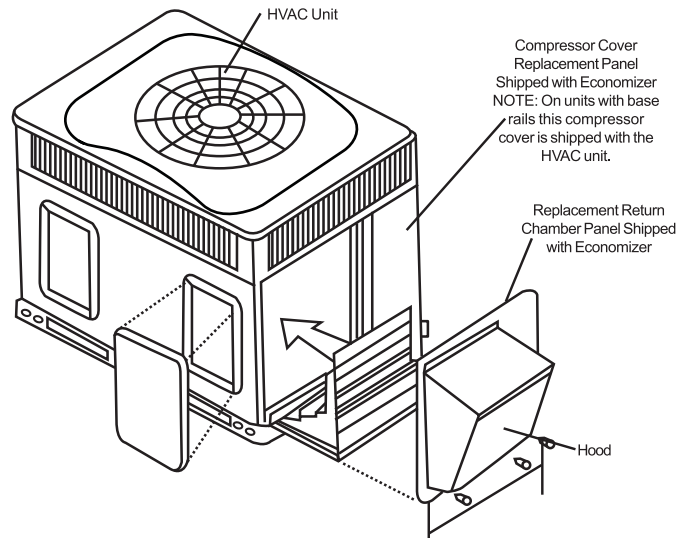
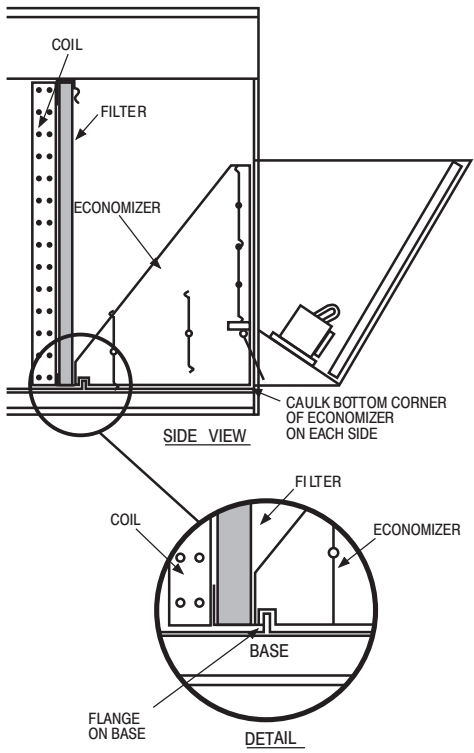

Vertical Economizer

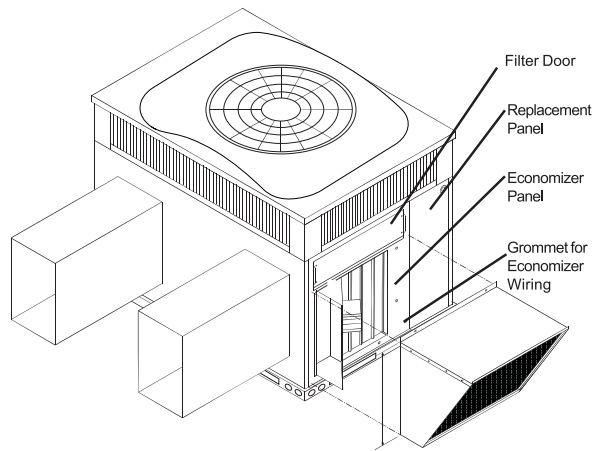

Horizontal Economizer

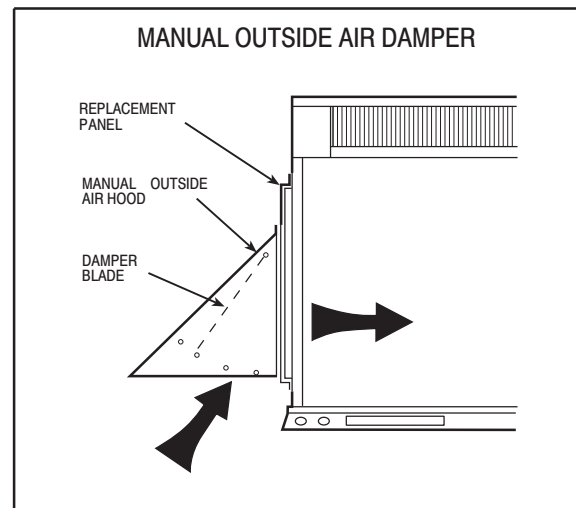
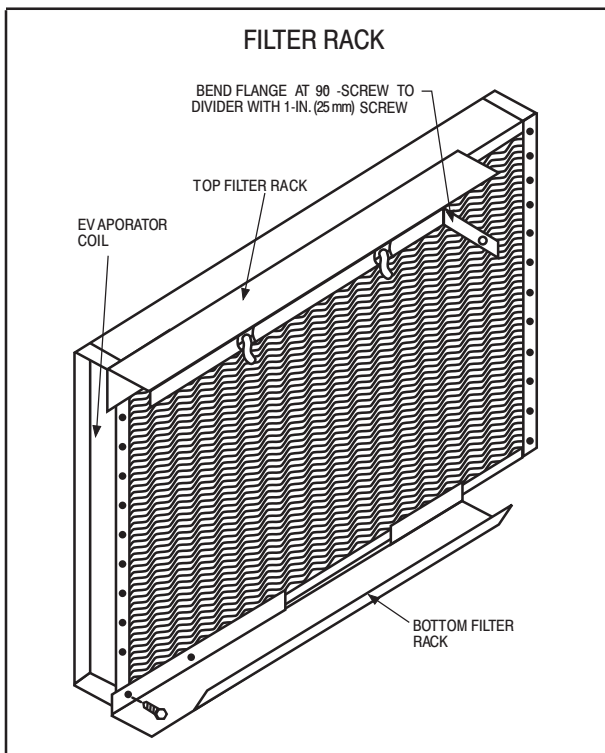

A09375

UNIT DIMENSIONS – 24–30

UNIT	ELECTRICAL CHARACTERISTICS		UNIT WT.		UNIT HEIGHT IN/MM		CENTER OF GRAVITY IN/MM		
	VOLTAGE	AMPERES	LB	KG	"A"	X	Y	Z	
PH0424000K(00/TP)0F1	208/230	46.7	21.2	9.3	47-3/4	20-1/2	521	15-1/2	394
PH0430000K(00/TP)0F1	208/230	52.7	23.9	10.8	51-3/4	20-1/2	521	15-1/2	394

UNIT	CORNER WEIGHT LBS/KG						
	"1"	"2"	"4"				
24	208/230	46.7	21.2	9.3	42.3	108.9	49.4
30	208/230	52.7	23.9	10.8	47.8	122.9	55.7

NOTE: ALL TABLE DATA RELEVANT FOR ALL FACTORY INSTALLED OPTIONS EXCEPT ECONOMIZER

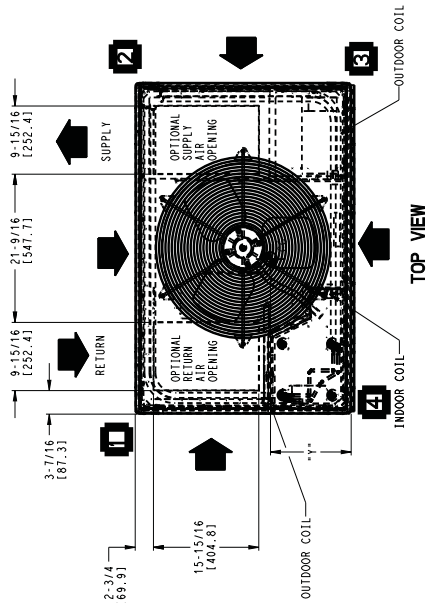

TOP VIEW

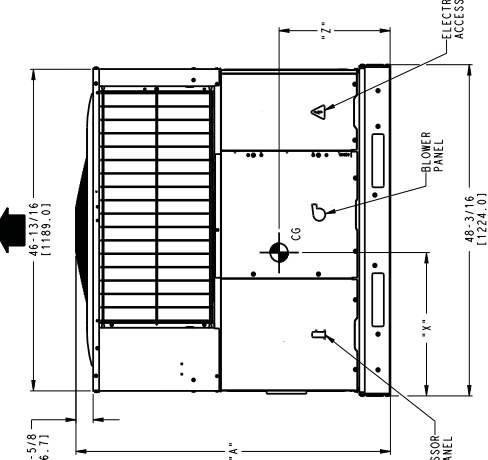

FRONT VIEW

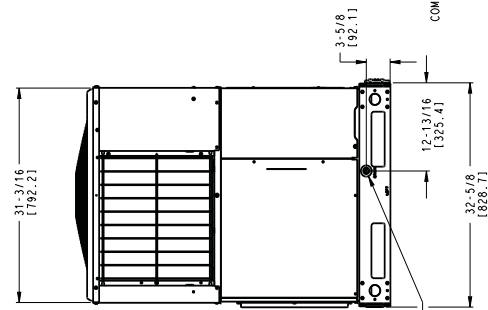

LEFT SIDE VIEW

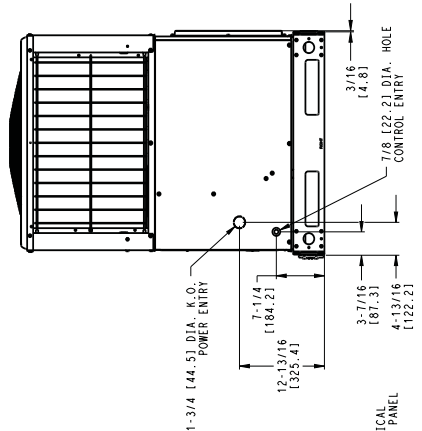

RIGHT SIDE VIEW

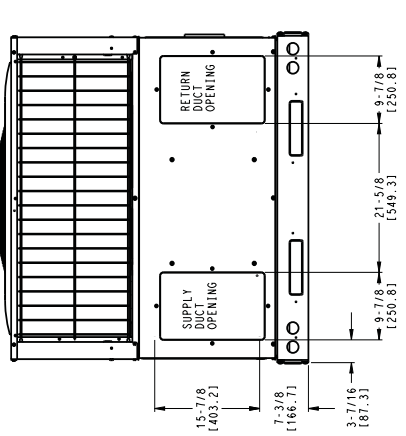

REAR VIEW

REQUIRED CLEARANCES TO COMBUSTIBLE MTL

TOP OF UNIT.....14 (355.6)
 DUCT SIDE OF UNIT.....2 (50.8)
 SIDE OPPOSITE DUCTS.....14 (355.6)
 BOTTOM OF UNIT.....14 (355.6)
 ELECTRICAL PANEL.....36 (914.4)

NEC REQUIRED CLEARANCES

BETWEEN UNITS, POWER ENTRY SIDE.....42 (1066.8)
 UNIT AND UNROUNDED SURFACES, POWER ENTRY SIDE.....36 (914.0)
 UNIT AND BLOCK OR CONCRETE WALLS AND OTHER GROUNDED SURFACES, POWER ENTRY SIDE.....42 (1066.8)

REQUIRED CLEARANCE FOR OPERATION AND SERVICING

FWP, COIL ACCESS SIDE.....36 (914.0)
 UNIT AND UNROUNDED SURFACES (EXCEPT FOR NEC REQUIREMENTS).....42 (1066.8)
 UNIT TOP.....48 (1219.2)
 SIDE OPPOSITE DUCTS.....36 (914.0)
 DUCT PANEL.....12 (304.8)

*MINIMUM DISTANCES: IF UNIT IS PLACED LESS THAN 12 (304.8) FROM WALL SYSTEM, THEN SYSTEM PERFORMANCE MAYBE COMPROMISED.

DIMENSIONS IN () ARE IN MILLIMETERS

50CY502940

UNIT DIMENSIONS – 36–60

UNIT	ELECTRICAL CHARACTERISTICS		UNIT WT.		UNIT HEIGHT IN/MM		CENTER OF GRAVITY IN/MM				
	PHD436000K/HAL100/TP10F1	PHD442000K/HAL100/TP10F1	PHD448000K/HAL100/TP10F1	PHD460000K/HAL100/TP10F1	LB	KG	"A"		Z		
	208/230-1-60, 208/230-3-60, 480-3-60	387	176.0	48-3/4	12.38	20-1/2	5.21	17-1/2	4.45	17-3/8	4.41
	208/230-1-60, 208/230-3-60, 480-3-60	435	197.0	54-3/4	13.91	20-1/2	5.21	17-1/2	4.45	17-3/8	4.48
	208/230-1-60, 208/230-3-60, 480-3-60	456	207.0	54-3/4	13.91	20-1/2	5.21	17-1/2	4.45	17-3/8	4.48
	208/230-1-60, 208/230-3-60, 480-3-60	487	221.0	48-3/4	12.38	20-1/2	5.21	17-1/2	4.45	18	4.57

UNIT	CORNER WEIGHTS LB/KG		
	"1"	"2"	"4"
36	208/230/460 38.1	26.3	77.4
42	208/230/460 65.3	29.6	87.0
48	208/230/460 86.4	31.0	91.2
60	208/230/460 133.1	33.1	97.4

REQUIRED CLEARANCES TO COMBUSTIBLE MATL.

	INCHES (MM)
TOP OF UNIT.....	14 (355.6)
DUCT SIDE OF UNIT.....	2 (50.8)
UPPER SURFACE OF DUCTS.....	2 (50.8)
BOTTOM OF UNIT.....	14 (355.6)
ELECTRICAL PANEL.....	36 (914.4)

NEC REQUIRED CLEARANCES:

	INCHES (MM)
BETWEEN UNITS, POWER ENTRY SIDE.....	1066.8
UNIT AND UNGROUNDED SURFACES, POWER ENTRY SIDE.....	36 (914.0)
UNIT AND BLOCK OR CONCRETE WALLS AND OTHER GROUNDED SURFACES, POWER ENTRY SIDE.....	42 (1066.8)

REQUIRED CLEARANCE FOR OPERATION AND SERVICING

	INCHES (MM)
EVAP. COIL ACCESS SIDE.....	36 (914.0)
POWER ENTRY SIDE.....	42 (1066.8)
UNITS FOR NEC REQUIREMENTS.....	48 (1219.2)
UNIT TOP FOR NEC REQUIREMENTS.....	36 (914.0)
SIDE OPPOSITE DUCTS.....	36 (914.0)
DUCT PANEL.....	12 (304.8)

*MINIMUM DISTANCES: IF UNIT IS PLACED LESS THAN 12" (304.8) FROM WALL SYSTEM, THEN SYSTEM PERFORMANCE MAYBE COMPROMISED.

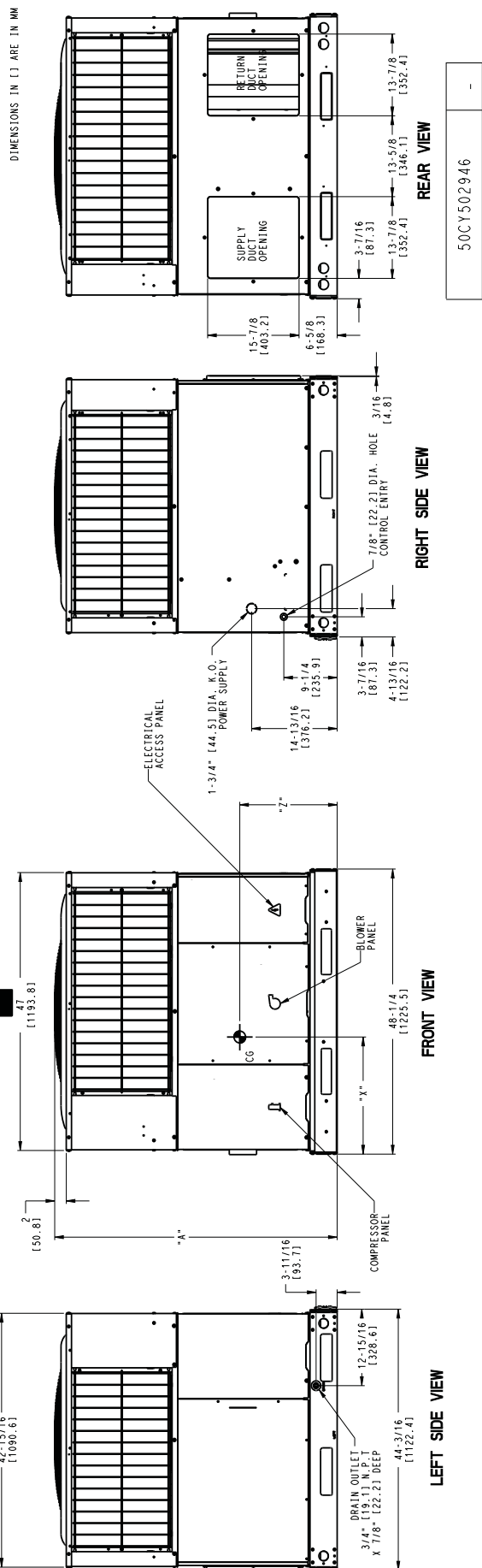

50CY502946

ROOF CURB ACCESSORY DIMENSIONS

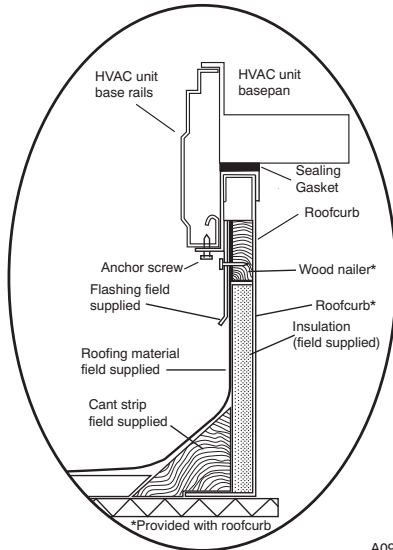

A09090

ROOF CURB DETAIL

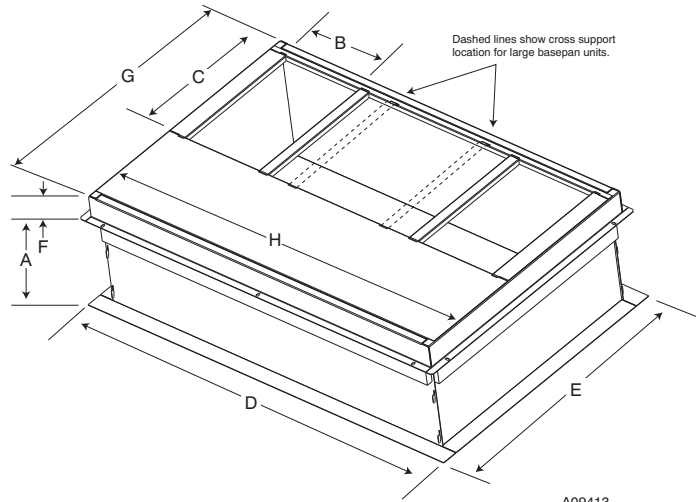

A09413

SMALL/COMMON CURB

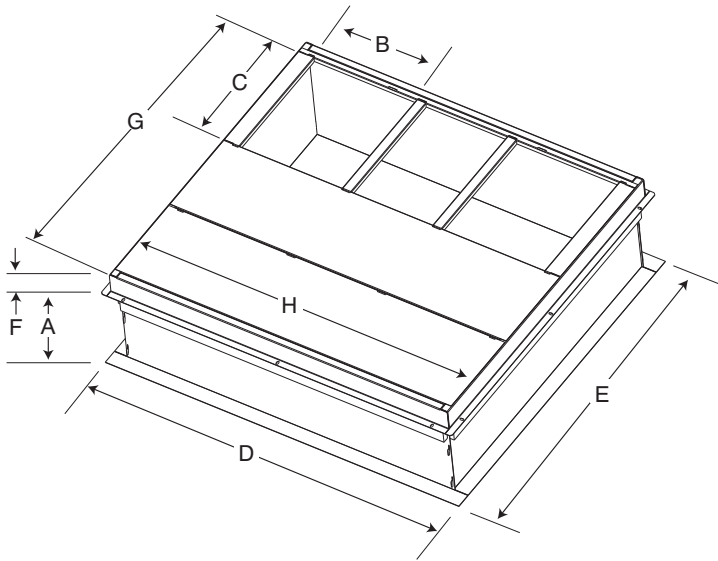

A09415

LARGE CURB

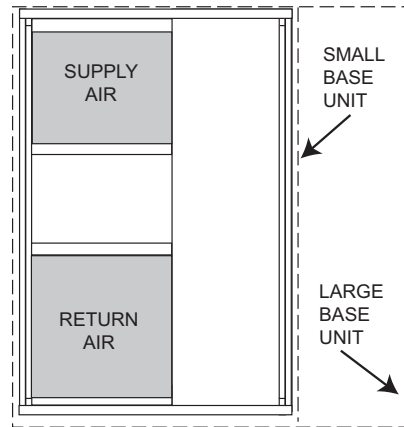

A09094

UNIT PLACEMENT ON COMMON CURB

SMALL OR LARGE BASE UNIT

A09414

UNIT SIZE	CATALOG NUMBER	A IN. (mm)	B (small/common base) IN. (mm)*	B (large base) IN. (mm)*	C IN. (mm)	D IN. (mm)	E IN. (mm)	F IN. (mm)	G IN. (mm)	H IN. (mm)
Small or Large	CPRFCURB011A00	14 (356)	10 (254)	14 (356)	16 (406)	47.8 (1214)	32.4 (822)	2.7 (69)	30.6 (778)	46.1 (1170)
Large	CPRFCURB013A00	14 (356)	14 (356)				43.9 (1116)		42.2 (1072)	

* Part Numbers CPRFCURB011A00 can be used on both small and large basepan units. The cross supports must be located based on whether the unit is a small basepan or a large basepan.

NOTES:

1. Roof curb must be set up for unit being installed.
2. Seal strip must be applied, as required, to unit being installed.
3. Roof curb is made of 16-gauge steel.
4. Attach ductwork to curb (flanges of duct rest on curb).
5. Insulated panels: 1-in. (25 mm) thick fiberglass 1 lb. density.

SELECTION PROCEDURE (WITH EXAMPLE)

1. Determine cooling and heating requirements at design conditions:

Given:

Required Cooling Capacity (TC) 34,500 Btuh
Sensible Heat Capacity (SHC) 26,000 Btuh
Required Heating Capacity 60,000 Btuh
Condenser Entering Air Temperature . . . 95°F (35°C)
Indoor–Air Temperature 80°F (27°C) edb 67°F (19°C) ewb
Evaporator Air Quantity 1200 CFM
External Static Pressure 0.200 IN. W.C.
Electrical Characteristics 208–1–60

2. Select unit based on required cooling capacity.

Enter Net Cooling Capacities table at condenser entering temperature of 95°F (35°C). Unit 36 at 1200 CFM and 67°F (19°C) ewb (entering wet bulb) will provide a total capacity of 35,800 Btuh and a SHC of 26,950 Btuh. Calculate SHC correction, if required, using Note 4 under Cooling Capacities tables.

3. Select heating capacity of unit to provide design condition requirement.

In the Heating Capacities and Efficiencies table, note that the 36 size unit will deliver 34,800 BTUH at the AHRI high temp rating point. To achieve 60,000 BTUH, accessory electric heat will be required. Use the Balance Point Worksheet to plot the load line with the unit capacity. The difference between the load line and unit capacity at the design heating temperature is the amount of electric heat that will be required.

4. Determine fan speed and power requirements at design conditions.

Before entering the air delivery tables, calculate the total static pressure required. From the given example, the Wet Coil Pressure Drop Table, and the Filter Pressure Drop Table:

External Static Pressure	0.200 IN. W.C.
Filter	0.130 IN. W.C.
Wet Coil Pressure Drop	<u>0.18</u> IN. W.C.
Total Static Pressure	0.51 IN. W.C.

Enter the table for Dry Coil Air Delivery— At 0.50 IN. W.C. ESP (external static pressure) and MED–LOW speed the motor delivers 1140 CFM. To achieve 1200 CFM, a higher speed tap is required.

5. Select unit that corresponds to power source available.

The Electrical Data Table shows that the unit is designed to operate at 208/230–1–60.

PERFORMANCE DATA

24 Cooling Extended Performance Table

EVAPORATOR AIR		CONDENSER ENTERING AIR TEMPERATURES °F (°C)																			
CFM	EWB °F (°C)	75 (23.9)			85 (29.4)			95 (35)			105 (40.6)			115 (46.1)			125 (51.7)				
		Capacity MBtuh	Total Sys KW	Sens	Capacity MBtuh	Total Sys KW	Sens	Capacity MBtuh	Total Sys KW	Sens	Capacity MBtuh	Total Sys KW	Sens	Capacity MBtuh	Total Sys KW	Sens	Capacity MBtuh	Total Sys KW	Sens		
700	57 (13.9)	23.20	1.46	21.89	1.66	20.49	1.88	19.02	2.13	17.49	2.41	15.90	2.74	15.90	2.41	15.90	2.74	15.90	2.41	15.90	2.74
	62 (16.7)	23.93	1.46	22.33	1.66	20.71	1.88	19.05	2.13	17.52	2.41	15.92	2.74	15.92	2.41	15.92	2.74	15.92	2.41	15.92	2.74
	63* (17.2)	24.31	1.46	22.69	1.66	21.03	1.88	19.29	2.13	17.49	2.41	15.64	2.74	15.64	2.41	15.64	2.74	15.64	2.41	15.64	2.74
	67 (19.4)	26.08	1.47	24.35	1.67	22.58	1.90	20.74	2.15	18.83	2.43	16.87	2.75	16.87	2.43	16.87	2.75	16.87	2.43	16.87	2.75
	72 (22.2)	28.46	1.48	26.60	1.69	24.70	1.91	22.73	2.17	20.69	2.46	18.58	2.78	18.58	2.46	18.58	2.78	18.58	2.46	18.58	2.78
	57 (13.9)	24.19	1.48	22.79	1.68	21.30	1.90	19.75	2.15	18.14	2.44	16.47	2.77	16.47	2.44	16.47	2.77	16.47	2.44	16.47	2.77
	62 (16.7)	24.54	1.48	22.92	1.68	21.33	1.90	19.78	2.15	18.17	2.44	16.49	2.77	16.49	2.44	16.49	2.77	16.49	2.44	16.49	2.77
800	63* (17.2)	24.87	1.48	23.18	1.68	21.43	1.90	19.63	2.15	17.77	2.44	15.88	2.76	15.88	2.44	15.88	2.76	15.88	2.44	15.88	2.76
	67 (19.4)	26.67	1.48	24.86	1.69	23.00	1.92	21.09	2.17	19.13	2.45	17.11	2.77	17.11	2.45	17.11	2.77	17.11	2.45	17.11	2.77
	72 (22.2)	29.10	1.49	27.14	1.71	25.15	1.94	23.10	2.19	20.99	2.48	18.80	2.80	18.80	2.48	18.80	2.80	18.80	2.48	18.80	2.80
	57 (13.9)	25.03	1.50	23.55	1.70	21.99	1.93	20.36	2.18	18.68	2.47	16.94	2.79	16.94	2.47	16.94	2.79	16.94	2.47	16.94	2.79
	62 (16.7)	25.10	1.50	23.58	1.70	22.02	1.93	20.39	2.18	18.71	2.47	16.96	2.79	16.96	2.47	16.96	2.79	16.96	2.47	16.96	2.79
	63* (17.2)	25.31	1.50	23.56	1.70	21.75	1.92	19.90	2.17	18.00	2.46	16.08	2.78	16.08	2.46	16.08	2.78	16.08	2.46	16.08	2.78
	67 (19.4)	27.13	1.50	25.24	1.71	23.33	1.94	21.37	2.19	19.36	2.48	17.30	2.80	17.30	2.48	17.30	2.80	17.30	2.48	17.30	2.80
72 (22.2)	29.60	1.51	27.57	1.73	25.50	1.96	23.39	2.21	21.21	2.50	18.98	2.82	18.98	2.50	18.98	2.82	18.98	2.50	18.98	2.82	

*At 75°F (23.9 °C) entering dry bulb—Tennessee Valley Authority [TVA] rating conditions; all others at 80°F (26.7 °C) entering dry bulb. See Legend and Notes.

24 Heating Extended Performance Table -10-60°F (-23.3-15.6°C)

INDOOR AIR		OUTDOOR COIL ENTERING AIR TEMPERATURES °F (°C)																							
EDB °F (°C)	CFM	-10 (-23.3)			0 (-17.8)			10 (-12.2)			20 (-6.7)			30 (-1.1)			40 (4.4)			50 (10)			60 (15.6)		
		Capacity MBtuh	Total Sys KW	Sens	Capacity MBtuh	Total Sys KW	Sens	Capacity MBtuh	Total Sys KW	Sens	Capacity MBtuh	Total Sys KW	Sens	Capacity MBtuh	Total Sys KW	Sens	Capacity MBtuh	Total Sys KW	Sens	Capacity MBtuh	Total Sys KW	Sens	Capacity MBtuh	Total Sys KW	Sens
65 (18.3)	700	5.16	4.74	1.30	7.34	6.76	1.36	9.88	9.07	1.42	13.05	11.84	1.49	16.15	14.15	1.54	19.76	19.76	1.60	23.93	23.93	1.67	28.94	28.94	1.78
	800	5.23	4.81	1.31	7.44	6.84	1.37	10.00	9.18	1.42	13.17	11.94	1.48	16.30	14.28	1.52	19.97	19.97	1.57	24.23	24.23	1.64	29.26	29.26	1.71
	900	5.29	4.87	1.32	7.52	6.92	1.37	10.10	9.27	1.42	13.27	12.04	1.47	16.43	14.40	1.51	20.15	20.15	1.56	24.47	24.47	1.61	29.31	29.31	1.67
70 (21.1)	700	4.96	4.56	1.36	7.13	6.56	1.42	9.64	8.85	1.49	12.86	11.66	1.56	15.94	13.96	1.62	19.49	19.49	1.68	23.59	23.59	1.76	28.47	28.47	1.86
	800	5.04	4.63	1.36	7.23	6.65	1.43	9.77	8.97	1.48	12.99	11.79	1.55	16.09	14.10	1.60	19.70	19.70	1.65	23.88	23.88	1.72	28.78	28.78	1.80
	900	5.11	4.70	1.37	7.31	6.73	1.43	9.88	9.07	1.48	13.11	11.89	1.54	16.23	14.22	1.59	19.88	19.88	1.63	24.12	24.12	1.69	29.00	29.00	1.76
75 (23.9)	700	4.74	4.36	1.42	6.89	6.34	1.49	9.39	8.62	1.56	12.31	11.16	1.62	15.73	13.78	1.70	19.22	19.22	1.76	23.28	23.28	1.84	28.02	28.02	1.95
	800	4.81	4.43	1.43	6.99	6.44	1.49	9.52	8.74	1.55	12.51	11.34	1.61	15.89	13.92	1.73	19.43	19.43	1.73	23.53	23.53	1.80	28.43	28.43	1.90
	900	4.89	4.50	1.44	7.08	6.52	1.50	9.63	8.84	1.55	12.71	11.53	1.61	16.01	14.03	1.67	19.61	19.61	1.71	23.77	23.77	1.78	28.65	28.65	1.85

PERFORMANCE DATA (CONT)

30 Cooling Extended Performance Table

EVAPORATOR AIR		CONDENSER ENTERING AIR TEMPERATURES °F (°C)																	
		75 (23.9)			85 (29.4)			95 (35)			105 (40.6)			115 (46.1)			125 (51.7)		
		CFM	EWB °F (°C)	Capacity MBtuh		Total Sys KW	Capacity MBtuh		Total Sys KW	Capacity MBtuh		Total Sys KW	Capacity MBtuh		Total Sys KW	Capacity MBtuh		Total Sys KW	
Total	Sens			Total	Sens		Total	Sens		Total	Sens		Total	Sens					
875	57 (13.9)	29.07	29.07	1.88	27.22	27.22	2.14	25.32	25.32	2.43	23.37	23.37	2.76	21.36	21.36	3.15	19.29	19.29	3.60
	62 (16.7)	29.99	25.80	1.89	27.81	24.76	2.14	25.64	23.67	2.43	23.47	23.30	2.76	21.39	21.39	3.15	19.32	19.32	3.60
	63* (17.2)	30.49	21.01	1.89	28.28	20.08	2.15	26.05	19.11	2.43	23.78	18.10	2.77	21.43	17.04	3.15	19.04	15.94	3.60
	67 (19.4)	32.82	21.81	1.91	30.45	20.88	2.16	28.08	19.91	2.45	25.64	18.90	2.78	23.16	17.85	3.17	20.61	16.76	3.60
	72 (22.2)	36.00	17.71	1.93	33.44	16.84	2.19	30.86	15.95	2.48	28.22	15.04	2.81	25.53	14.11	3.19	22.78	13.13	3.62
1000	57 (13.9)	30.31	30.31	1.92	28.34	28.34	2.18	26.34	26.34	2.47	24.28	24.28	2.80	22.17	22.17	3.19	19.99	19.99	3.64
	62 (16.7)	30.74	27.66	1.92	28.52	26.50	2.18	26.38	26.38	2.47	24.32	24.32	2.80	22.20	22.20	3.19	20.02	20.02	3.64
	63* (17.2)	31.18	22.37	1.93	28.86	21.41	2.18	26.55	20.41	2.47	24.19	19.37	2.80	21.78	18.26	3.19	19.33	17.11	3.63
	67 (19.4)	33.54	23.28	1.94	31.07	22.31	2.20	28.60	21.30	2.49	26.08	20.25	2.82	23.52	19.15	3.20	20.91	18.02	3.64
	72 (22.2)	36.76	18.67	1.96	34.09	17.77	2.22	31.41	16.84	2.51	28.68	15.90	2.84	25.91	14.92	3.22	23.08	13.91	3.66
1125	57 (13.9)	31.37	31.37	1.96	29.29	29.29	2.22	27.19	27.19	2.51	25.04	25.04	2.84	22.83	22.83	3.23	20.57	20.57	3.67
	62 (16.7)	31.43	31.43	1.96	29.33	29.33	2.22	27.23	27.23	2.51	25.07	25.07	2.84	22.86	22.86	3.23	20.59	20.59	3.67
	63* (17.2)	31.70	23.68	1.96	29.31	22.69	2.22	26.93	21.64	2.50	24.52	20.54	2.84	22.05	19.41	3.22	19.56	18.20	3.67
	67 (19.4)	34.09	24.70	1.98	31.54	23.68	2.23	29.00	22.63	2.52	26.42	21.53	2.85	23.79	20.40	3.24	21.13	19.20	3.68
	72 (22.2)	37.37	19.54	2.00	34.61	18.61	2.26	31.85	17.66	2.55	29.03	16.69	2.88	26.19	15.69	3.26	23.29	14.66	3.69

*At 75°F (23.9 °C) entering dry bulb—Tennessee Valley Authority [TVA] rating conditions; all others at 80°F (26.7 °C) entering dry bulb. See Legend and Notes.

30 Heating Extended Performance Table -10-60°F (-23.3-15.6°C)

INDOOR AIR		OUTDOOR COIL ENTERING AIR TEMPERATURES °F (°C)																							
		-10 (-23.3)			0 (-17.8)			10 (-12.2)			20 (-6.7)			30 (-1.1)			40 (4.4)			50 (10)			60 (15.6)		
		EDB °F (°C)	CFM	Capacity MBtuh		Total Sys KW	Capacity MBtuh		Total Sys KW	Capacity MBtuh		Total Sys KW	Capacity MBtuh		Total Sys KW	Capacity MBtuh		Total Sys KW	Capacity MBtuh		Total Sys KW	Capacity MBtuh		Total Sys KW	
Total	Integ			Total	Integ		Total	Integ		Total	Integ		Total	Integ		Total	Integ		Total	Integ		Total	Integ		
65 (18.3)	875	7.37	6.78	1.70	10.15	9.34	1.76	13.27	12.18	1.82	16.92	15.35	1.88	20.92	18.33	1.95	25.08	25.08	2.01	29.90	29.90	2.09	35.71	35.71	2.21
	1000	7.52	6.92	1.72	10.33	9.50	1.77	13.47	12.37	1.82	17.43	15.81	1.89	21.13	18.51	1.93	25.36	25.36	1.98	30.29	30.29	2.06	36.23	36.23	2.16
	1125	7.66	7.04	1.74	10.49	9.65	1.79	13.66	12.53	1.83	17.61	15.97	1.89	21.32	18.68	1.93	25.59	25.59	1.97	30.61	30.61	2.04	36.66	36.66	2.14
70 (21.1)	875	6.96	6.40	1.77	9.76	8.98	1.84	12.89	11.83	1.90	16.44	14.91	1.97	20.65	18.10	2.04	24.77	24.77	2.11	29.48	29.48	2.19	35.19	35.19	2.31
	1000	7.11	6.54	1.79	9.94	9.15	1.85	13.09	12.02	1.90	16.70	15.15	1.96	20.88	18.30	2.03	25.05	25.05	2.08	29.87	29.87	2.16	35.70	35.70	2.26
	1125	7.24	6.66	1.81	10.09	9.28	1.87	13.27	12.18	1.91	16.95	15.37	1.97	21.07	18.46	2.02	25.28	25.28	2.07	30.18	30.18	2.13	36.11	36.11	2.23
75 (23.9)	875	6.52	6.00	1.85	9.34	8.59	1.92	12.48	11.46	1.99	16.02	14.53	2.06	20.40	17.87	2.15	24.46	24.46	2.21	29.09	29.09	2.30	34.68	34.68	2.42
	1000	6.67	6.13	1.87	9.52	8.76	1.93	12.69	11.65	1.99	16.28	14.76	2.05	20.61	18.06	2.13	24.73	24.73	2.18	29.44	29.44	2.26	35.17	35.17	2.37
	1125	6.80	6.25	1.89	9.67	8.90	1.95	12.87	11.82	2.00	16.49	14.96	2.06	20.80	18.22	2.12	24.96	24.96	2.17	29.75	29.75	2.24	35.58	35.58	2.34

PERFORMANCE DATA (CONT)

36 Cooling Extended Performance Table

EVAPORATOR AIR		CONDENSER ENTERING AIR TEMPERATURES °F (°C)																		
CFM	EWB °F (°C)	75 (23.9)			85 (29.4)			95 (35)			105 (40.6)			115 (46.1)			125 (51.7)			
		Capacity MBtuh	Total Sys KW	Sens	Capacity MBtuh	Total Sys KW	Sens	Capacity MBtuh	Total Sys KW	Sens	Capacity MBtuh	Total Sys KW	Sens	Capacity MBtuh	Total Sys KW	Sens	Capacity MBtuh	Total Sys KW	Sens	
1050	57 (13.9)	34.29	2.28	31.97	2.57	29.65	2.91	27.29	3.30	24.91	3.75	22.51	4.28	20.33	4.71	17.98	5.14	15.64	5.51	13.34
	62 (16.7)	35.83	2.28	30.41	2.58	30.40	2.91	27.69	3.30	24.97	3.75	22.54	4.28	20.33	4.71	17.98	5.14	15.64	5.51	13.34
	63* (17.2)	36.58	2.29	33.81	2.58	31.02	2.92	28.22	3.31	25.40	3.76	22.56	4.28	20.33	4.71	17.98	5.14	15.64	5.51	13.34
	67 (19.4)	39.49	2.30	36.51	2.60	33.53	2.94	30.54	3.33	27.53	3.78	24.50	4.29	20.33	4.71	17.98	5.14	15.64	5.51	13.34
	72 (22.2)	43.46	2.33	40.22	2.63	36.98	2.97	33.73	3.36	30.47	3.80	27.18	4.31	20.33	4.71	17.98	5.14	15.64	5.51	13.34
1200	57 (13.9)	35.76	2.31	33.32	2.61	30.86	2.95	28.38	3.34	25.88	3.79	23.36	4.31	20.33	4.71	17.98	5.14	15.64	5.51	13.34
	62 (16.7)	36.70	2.32	33.91	2.61	31.14	2.95	28.43	3.34	25.91	3.79	23.38	4.31	20.33	4.71	17.98	5.14	15.64	5.51	13.34
	63* (17.2)	37.43	2.32	34.56	2.62	31.66	2.95	28.77	3.34	25.86	3.79	22.94	4.31	20.33	4.71	17.98	5.14	15.64	5.51	13.34
	67 (19.4)	40.37	2.34	37.29	2.64	34.20	2.97	31.11	3.36	28.01	3.81	24.89	4.32	20.33	4.71	17.98	5.14	15.64	5.51	13.34
	72 (22.2)	44.39	2.36	41.05	2.67	37.70	3.01	34.35	3.39	30.98	3.84	27.60	4.35	20.33	4.71	17.98	5.14	15.64	5.51	13.34
1350	57 (13.9)	37.01	2.35	34.46	2.65	31.89	2.98	29.30	3.37	26.69	3.83	24.06	4.35	20.33	4.71	17.98	5.14	15.64	5.51	13.34
	62 (16.7)	37.46	2.35	34.56	2.65	31.92	2.98	29.33	3.37	26.72	3.83	24.09	4.35	20.33	4.71	17.98	5.14	15.64	5.51	13.34
	63* (17.2)	38.10	2.35	35.13	2.65	32.17	2.98	29.19	3.37	26.21	3.82	23.24	4.34	20.33	4.71	17.98	5.14	15.64	5.51	13.34
	67 (19.4)	41.06	2.37	37.88	2.67	34.72	2.98	31.55	3.39	28.36	3.84	25.19	4.35	20.33	4.71	17.98	5.14	15.64	5.51	13.34
	72 (22.2)	45.13	2.40	41.68	2.70	38.26	3.04	34.81	3.43	31.36	3.87	27.91	4.38	20.33	4.71	17.98	5.14	15.64	5.51	13.34

*At 75°F (23.9 °C) entering dry bulb—Tennessee Valley Authority (TVA) rating conditions; all others at 80°F (26.7 °C) entering dry bulb. See Legend and Notes.

36 Heating Extended Performance Table -10-60 °F (-23.3-15.6 °C)

INDOOR AIR		OUTDOOR COIL ENTERING AIR TEMPERATURES °F (°C)																							
EDB °F (°C)	CFM	-10 (-23.3)			0 (-17.8)			10 (-12.2)			20 (-6.7)			30 (-1.1)			40 (4.4)			50 (10)			60 (15.6)		
		Capacity MBtuh	Total Sys KW	Sens	Capacity MBtuh	Total Sys KW	Sens	Capacity MBtuh	Total Sys KW	Sens	Capacity MBtuh	Total Sys KW	Sens	Capacity MBtuh	Total Sys KW	Sens	Capacity MBtuh	Total Sys KW	Sens	Capacity MBtuh	Total Sys KW	Sens	Capacity MBtuh	Total Sys KW	Sens
65 (18.3)	1050	8.91	8.20	1.99	12.09	11.12	2.10	15.84	14.54	2.20	20.16	18.29	2.51	25.50	22.34	2.46	30.51	30.51	2.59	36.18	36.18	2.74	42.89	42.89	2.94
	1200	9.08	8.35	2.00	12.29	11.31	2.10	16.09	14.77	2.19	20.48	18.57	2.29	25.78	22.58	2.42	30.85	30.85	2.54	36.62	36.62	2.68	43.51	43.51	2.86
	1350	9.23	8.49	2.02	12.47	11.48	2.11	16.30	14.96	2.19	20.74	18.81	2.28	25.99	22.77	2.40	31.14	31.14	2.51	36.99	36.99	2.63	44.03	44.03	2.80
70 (21.1)	1050	8.38	7.71	2.09	11.57	10.64	2.20	15.32	14.06	2.30	19.62	17.80	2.42	25.09	21.99	2.58	30.10	30.10	2.71	35.72	35.72	2.87	42.28	42.28	3.08
	1200	8.55	7.86	2.10	11.77	10.83	2.20	15.57	14.29	2.30	19.93	18.08	2.40	25.40	22.25	2.54	30.44	30.44	2.66	36.14	36.14	2.80	42.89	42.89	2.99
	1350	8.69	8.00	2.12	11.95	10.99	2.21	15.78	14.49	2.30	20.20	18.32	2.39	25.64	22.47	2.52	30.73	30.73	2.63	36.50	36.50	2.76	43.39	43.39	2.93
75 (23.9)	1050	7.83	7.20	2.20	11.02	10.14	2.30	14.78	13.56	2.41	19.06	17.29	2.53	24.02	21.05	2.67	29.70	29.70	2.85	35.30	35.30	3.01	41.68	41.68	3.22
	1200	7.98	7.34	2.21	11.22	10.32	2.31	15.02	13.79	2.41	19.37	17.57	2.51	24.54	21.50	2.64	30.03	30.03	2.79	35.70	35.70	2.94	42.27	42.27	3.13
	1350	8.12	7.47	2.22	11.40	10.49	2.32	15.24	13.98	2.41	19.63	17.80	2.50	25.23	22.10	2.64	30.31	30.31	2.75	36.01	36.01	2.89	42.76	42.76	3.07

PERFORMANCE DATA (CONT)

42 Cooling Extended Performance Table

EVAPORATOR AIR		CONDENSER ENTERING AIR TEMPERATURES °F (°C)																	
		75 (23.9)			85 (29.4)			95 (35)			105 (40.6)			115 (46.1)			125 (51.7)		
		CFM	EWB °F (°C)	Capacity MBtuh		Total Sys KW	Capacity MBtuh		Total Sys KW	Capacity MBtuh		Total Sys KW	Capacity MBtuh		Total Sys KW	Capacity MBtuh		Total Sys KW	
Total	Sens			Total	Sens		Total	Sens		Total	Sens		Total	Sens					
1175	57 (13.9)	41.22	41.22	2.67	38.65	38.65	3.02	36.03	36.03	3.43	33.36	33.36	3.92	30.67	30.67	4.50	27.95	27.95	5.18
	62 (16.7)	42.88	35.64	2.68	39.82	33.67	3.03	36.79	31.68	3.45	33.74	29.66	3.93	30.72	30.72	4.50	28.00	28.00	5.18
	63* (17.2)	43.45	29.05	2.69	40.36	27.34	3.04	37.28	25.64	3.45	34.17	23.94	3.94	31.05	22.25	4.51	27.90	20.56	5.18
	67 (19.4)	46.78	30.15	2.73	43.42	28.38	3.08	40.10	26.62	3.50	36.77	24.88	4.00	33.43	23.16	4.58	30.08	21.45	5.25
	72 (22.2)	51.06	24.68	2.78	47.40	23.07	3.14	43.79	21.48	3.57	40.20	19.91	4.08	36.60	18.37	4.68	32.99	16.84	5.37
	57 (13.9)	43.16	43.16	2.73	40.38	40.38	3.08	37.57	37.57	3.50	34.75	34.75	4.00	31.90	31.90	4.58	29.02	29.02	5.26
	62 (16.7)	44.08	38.33	2.74	40.92	36.18	3.09	37.79	33.95	3.51	34.81	34.81	3.99	31.95	31.95	4.58	29.06	29.06	5.26
1350	63* (17.2)	44.59	30.98	2.75	41.33	29.18	3.10	38.10	27.39	3.51	34.87	25.62	4.00	31.64	23.84	4.57	28.39	22.06	5.24
	67 (19.4)	47.99	32.21	2.78	44.45	30.35	3.14	41.00	28.50	3.57	37.54	26.68	4.06	34.07	24.87	4.64	30.60	23.06	5.32
	72 (22.2)	52.34	25.96	2.84	48.53	24.28	3.21	44.76	22.63	3.64	41.02	21.01	4.15	37.28	19.40	4.75	33.55	17.83	5.44
	57 (13.9)	44.79	44.79	2.79	41.81	41.81	3.15	38.87	38.87	3.57	35.90	35.90	4.07	32.91	32.91	4.66	29.90	29.90	5.34
	62 (16.7)	45.17	40.72	2.79	41.88	41.88	3.15	38.92	38.92	3.57	35.95	35.95	4.07	32.96	32.96	4.66	29.94	29.94	5.35
	63* (17.2)	45.49	32.82	2.80	42.10	30.94	3.15	38.77	29.08	3.57	35.43	27.21	4.06	32.09	25.34	4.63	28.77	23.46	5.30
	67 (19.4)	48.94	34.19	2.84	45.27	32.23	3.20	41.68	30.32	3.62	38.10	28.40	4.12	34.56	26.50	4.71	31.00	24.58	5.39
72 (22.2)	53.35	27.17	2.90	49.40	25.43	3.27	45.51	23.72	3.70	41.65	22.04	4.21	37.80	20.39	4.81	33.97	18.77	5.51	

*At 75°F (23.9 °C) entering dry bulb—Tennessee Valley Authority (TVA) rating conditions; all others at 80°F (26.7 °C) entering dry bulb. See Legend and Notes.

42 Heating Extended Performance Table -10-60 °F (-23.3-15.6 °C)

INDOOR AIR		OUTDOOR COIL ENTERING AIR TEMPERATURES °F (°C)																							
		-10 (-23.3)			0 (-17.8)			10 (-12.2)			20 (-6.7)			30 (-1.1)			40 (4.4)			50 (10)			60 (15.6)		
		EDB °F (°C)	CFM	Capacity MBtuh		Total Sys KW	Capacity MBtuh		Total Sys KW	Capacity MBtuh		Total Sys KW	Capacity MBtuh		Total Sys KW	Capacity MBtuh		Total Sys KW	Capacity MBtuh		Total Sys KW	Capacity MBtuh		Total Sys KW	
Total	Integ			Total	Integ		Total	Integ		Total	Integ		Total	Integ		Total	Integ		Total	Integ		Total	Integ		
65 (18.3)	1175	10.12	9.31	2.30	14.66	13.49	2.50	19.40	17.81	2.66	24.41	22.14	2.80	29.75	26.06	2.94	35.60	31.11	3.32	41.91	41.91	3.32	48.00	48.00	3.56
	1350	10.35	9.52	2.33	14.93	13.74	2.52	19.74	18.12	2.67	24.85	22.53	2.79	30.28	26.53	2.92	36.96	32.09	3.25	42.46	42.46	3.25	48.76	48.76	3.47
	1525	10.56	9.71	2.36	15.19	13.97	2.54	20.05	18.40	2.69	25.21	22.86	2.80	30.72	26.92	2.91	37.37	32.07	3.21	42.93	42.93	3.21	49.39	49.39	3.41
70 (21.1)	1175	9.48	8.72	2.42	13.96	12.84	2.62	18.67	17.13	2.78	23.68	21.48	2.92	28.98	25.39	3.07	34.72	34.72	3.24	41.44	41.44	3.24	47.32	47.32	3.73
	1350	9.71	8.94	2.45	14.25	13.11	2.64	19.04	17.47	2.79	24.12	21.88	2.92	29.51	25.86	3.05	35.45	35.45	3.21	41.94	41.94	3.21	48.04	48.04	3.64
	1525	9.91	9.12	2.48	14.51	13.36	2.66	19.35	17.76	2.81	24.49	22.21	2.93	29.96	26.25	3.04	36.79	36.79	3.21	42.34	42.34	3.21	48.65	48.65	3.57
75 (23.9)	1175	8.70	8.01	2.54	13.17	12.12	2.74	17.88	16.41	2.90	22.89	20.76	3.05	28.17	24.68	3.20	33.86	33.86	3.38	40.88	40.88	3.38	46.68	46.68	3.92
	1350	8.93	8.22	2.57	13.47	12.40	2.76	18.25	16.75	2.91	23.34	21.17	3.05	28.70	25.15	3.18	34.52	34.52	3.35	41.42	41.42	3.35	47.36	47.36	3.81
	1525	9.14	8.41	2.61	13.74	12.64	2.79	18.57	17.04	2.93	23.72	21.51	3.06	29.16	25.55	3.18	35.06	35.06	3.33	41.87	41.87	3.33	47.94	47.94	3.75

PERFORMANCE DATA (CONT)

48 Cooling Extended Performance Table

EVAPORATOR AIR		CONDENSER ENTERING AIR TEMPERATURES °F (°C)																	
		75 (23.9)			85 (29.4)			95 (35)			105 (40.6)			115 (46.1)			125 (51.7)		
		CFM	EWB °F (°C)	Capacity MBtuh		Total Sys KW	Capacity MBtuh		Total Sys KW	Capacity MBtuh		Total Sys KW	Capacity MBtuh		Total Sys KW	Capacity MBtuh		Total Sys KW	
Total	Sens			Total	Sens		Total	Sens		Total	Sens		Total	Sens					
1400	57 (13.9)	50.12	50.12	3.10	46.77	46.77	3.47	43.47	43.47	3.90	39.22	39.22	4.36	34.90	34.90	4.88	30.65	30.65	5.48
	62 (16.7)	51.55	44.71	3.10	47.78	41.45	3.48	44.03	38.34	3.91	39.31	39.31	4.36	34.97	34.97	4.88	30.70	30.70	5.48
	63* (17.2)	52.39	36.35	3.11	48.52	33.63	3.48	44.63	30.99	3.91	39.88	28.04	4.37	34.46	24.92	4.87	29.23	21.95	5.45
	67 (19.4)	55.61	37.17	3.13	51.57	34.45	3.51	47.38	31.68	3.94	43.53	29.46	4.42	38.57	26.58	4.97	32.97	23.55	5.53
	72 (22.2)	59.62	29.72	3.15	55.39	27.41	3.53	50.95	25.03	3.97	46.47	22.65	4.46	42.63	20.90	5.01	37.81	18.74	5.62
	57 (13.9)	51.78	51.78	3.16	48.29	48.29	3.54	44.77	44.77	3.97	41.24	41.24	4.46	36.65	36.65	4.99	32.12	32.12	5.57
	62 (16.7)	52.53	47.41	3.16	48.70	43.96	3.54	44.85	44.85	3.97	41.31	41.31	4.46	36.71	36.71	4.99	32.17	32.17	5.58
1600	63* (17.2)	53.23	38.40	3.17	49.26	35.59	3.54	45.25	32.81	3.97	40.90	30.12	4.46	35.28	26.82	4.95	29.90	23.64	5.52
	67 (19.4)	56.41	39.18	3.19	52.28	36.36	3.57	48.00	33.50	4.00	43.94	31.01	4.49	39.39	28.67	5.03	33.68	25.41	5.62
	72 (22.2)	60.37	30.80	3.21	56.05	28.44	3.59	51.53	25.98	4.03	46.91	23.51	4.53	42.97	21.80	5.08	38.26	19.80	5.69
	57 (13.9)	53.08	53.08	3.22	49.47	49.47	3.60	45.76	45.76	4.04	42.48	42.48	4.53	38.09	38.09	5.08	33.40	33.40	5.67
	62 (16.7)	53.36	49.71	3.22	49.54	49.54	3.60	45.79	45.79	4.04	42.53	42.53	4.53	38.15	38.15	5.08	33.45	33.45	5.67
	63* (17.2)	53.86	40.35	3.23	49.82	37.43	3.61	45.70	34.51	4.04	41.62	32.13	4.51	35.97	28.61	5.03	30.48	25.13	5.60
	67 (19.4)	57.01	41.09	3.25	52.81	38.19	3.63	48.44	35.21	4.06	44.19	32.41	4.55	39.90	30.52	5.09	34.30	27.16	5.70
72 (22.2)	60.93	31.81	3.27	56.55	29.40	3.65	51.95	26.88	4.09	47.23	24.35	4.59	43.19	22.58	5.15	38.57	20.77	5.75	

*At 75°F (23.9°C) entering dry bulb—Tennessee Valley Authority (TVA) rating conditions; all others at 80°F (26.7°C) entering dry bulb. See Legend and Notes.

48 Heating Extended Performance Table -10-60°F (-23.3-15.6°C)

INDOOR AIR		OUTDOOR COIL ENTERING AIR TEMPERATURES °F (°C)																							
		-10 (-23.3)			0 (-17.8)			10 (-12.2)			20 (-6.7)			30 (-1.1)			40 (4.4)			50 (10)			60 (15.6)		
		EDB CFM	Capacity MBtuh	Total Sys KW	Capacity MBtuh	Total Sys KW	Capacity MBtuh	Total Sys KW	Capacity MBtuh	Total Sys KW	Capacity MBtuh	Total Sys KW	Capacity MBtuh	Total Sys KW	Capacity MBtuh	Total Sys KW	Capacity MBtuh	Total Sys KW	Capacity MBtuh	Total Sys KW	Capacity MBtuh	Total Sys KW			
Total	Integ																						Total	Integ	Total
65 (18.3)	1400	12.87	11.84	2.61	17.23	15.86	2.76	22.14	20.32	2.90	27.76	25.18	3.07	34.69	30.39	3.25	40.97	40.97	3.40	48.22	48.22	3.59	56.85	56.85	3.82
	1600	13.16	12.11	2.64	17.57	16.17	2.78	22.53	20.68	2.92	28.19	25.57	3.07	35.00	30.66	3.23	41.41	41.41	3.36	48.82	48.82	3.53	57.70	57.70	3.74
	1800	13.42	12.35	2.68	17.87	16.44	2.81	22.86	20.98	2.94	28.58	25.92	3.08	35.31	30.94	3.23	41.80	41.80	3.35	49.33	49.33	3.50	58.41	58.41	3.70
70 (21.1)	1400	12.17	11.19	2.71	16.57	15.24	2.87	21.48	19.71	3.02	27.09	24.56	3.19	34.27	30.03	3.40	40.56	40.56	3.56	47.61	47.61	3.75	56.05	56.05	3.99
	1600	12.45	11.45	2.75	16.90	15.55	2.89	21.85	20.06	3.04	27.53	24.96	3.20	34.66	30.37	3.38	40.97	40.97	3.52	48.20	48.20	3.70	56.84	56.84	3.90
	1800	12.71	11.69	2.79	17.18	15.80	2.92	22.19	20.36	3.06	27.91	25.31	3.21	34.99	30.66	3.38	41.34	41.34	3.50	48.71	48.71	3.67	57.58	57.58	3.87
75 (23.9)	1400	11.44	10.52	2.82	15.86	14.59	2.99	20.79	19.09	3.15	26.39	23.94	3.33	32.89	28.81	3.51	40.10	40.10	3.73	47.02	47.02	3.93	55.27	55.27	4.18
	1600	11.72	10.78	2.86	16.18	14.89	3.01	21.17	19.43	3.17	26.83	24.34	3.33	33.55	29.40	3.50	40.56	40.56	3.69	47.59	47.59	3.87	56.04	56.04	4.09
	1800	11.97	11.01	2.90	16.47	15.16	3.04	21.50	19.73	3.19	27.21	24.68	3.34	34.55	30.27	3.53	40.92	40.92	3.67	48.08	48.08	3.83	56.73	56.73	4.04

PERFORMANCE DATA (CONT)

60 Cooling Extended Performance Table

EVAPORATOR AIR		CONDENSER ENTERING AIR TEMPERATURES °F (°C)																	
		75 (23.9)			85 (29.4)			95 (35)			105 (40.6)			115 (46.1)			125 (51.7)		
		CFM	EWB °F (°C)	Capacity MBtuh		Total Sys KW	Capacity MBtuh		Total Sys KW	Capacity MBtuh		Total Sys KW	Capacity MBtuh		Total Sys KW	Capacity MBtuh		Total Sys KW	
Total	Sens			Total	Sens		Total	Sens		Total	Sens		Total	Sens					
1750	57 (13.9)	59.01	59.01	3.86	55.84	55.84	4.36	52.53	52.53	4.95	49.01	49.01	5.63	45.25	45.25	6.42	41.25	41.25	7.30
	62 (16.7)	60.65	51.45	3.87	56.94	49.66	4.37	53.07	47.70	4.96	49.10	49.10	5.63	45.32	45.32	6.42	41.31	41.31	7.30
	63* (17.2)	61.42	41.59	3.88	57.58	40.01	4.38	53.66	38.36	4.96	49.53	36.63	5.64	45.16	34.80	6.42	40.58	32.86	7.29
	67 (19.4)	65.91	43.15	3.90	61.77	41.51	4.41	57.50	39.80	5.00	53.02	38.01	5.68	48.31	36.13	6.46	43.40	34.17	7.34
	72 (22.2)	71.65	34.81	3.93	67.13	33.24	4.45	62.46	31.58	5.05	57.59	29.86	5.73	52.50	28.06	6.52	47.21	26.18	7.40
	57 (13.9)	61.36	61.36	3.95	57.93	57.93	4.46	54.38	54.38	5.05	50.64	50.64	5.73	46.62	46.62	6.52	42.39	42.39	7.41
2000	62 (16.7)	62.11	54.99	3.96	58.19	57.61	4.46	54.45	54.45	5.05	50.70	50.70	5.73	46.68	46.68	6.52	42.45	42.45	7.41
	63* (17.2)	62.66	44.18	3.96	58.67	42.54	4.46	54.56	40.83	5.05	50.26	39.04	5.73	45.71	37.12	6.51	41.01	35.05	7.38
	67 (19.4)	67.23	45.93	3.98	62.89	44.22	4.49	58.43	42.45	5.09	53.75	40.59	5.77	48.89	38.64	6.55	43.85	36.55	7.43
	72 (22.2)	73.06	36.47	4.01	68.34	34.84	4.53	63.48	33.14	5.13	58.41	31.35	5.82	53.15	29.51	6.61	47.69	27.59	7.49
	57 (13.9)	63.30	63.30	4.04	59.65	59.65	4.55	55.89	55.89	5.14	51.92	51.92	5.83	47.72	47.72	6.62	43.32	43.32	7.51
	62 (16.7)	63.38	63.38	4.04	59.73	59.73	4.55	55.96	55.96	5.14	51.98	51.98	5.83	47.77	47.77	6.62	43.36	43.36	7.51
2250	63* (17.2)	63.63	46.69	4.04	59.48	44.99	4.55	55.23	43.21	5.14	50.79	41.33	5.82	46.15	39.28	6.60	41.34	37.04	7.48
	67 (19.4)	68.23	48.62	4.06	63.75	46.87	4.58	59.13	45.03	5.17	54.33	43.09	5.86	49.34	41.00	6.64	44.19	38.75	7.52
	72 (22.2)	74.14	38.06	4.09	69.26	36.38	4.61	64.22	34.62	5.22	59.02	32.81	5.91	53.61	30.91	6.70	48.02	28.95	7.59

*At 75°F (23.9 °C) entering dry bulb—Tennessee Valley Authority [TVA] rating conditions; all others at 80°F (26.7 °C) entering dry bulb. See Legend and Notes.

60 Heating Extended Performance Table -10-60°F (-23.3-15.6 °C)

INDOOR AIR		OUTDOOR COIL ENTERING AIR TEMPERATURES °F (°C)																							
		-10 (-23.3)			0 (-17.8)			10 (-12.2)			20 (-6.7)			30 (-1.1)			40 (4.4)			50 (10)			60 (15.6)		
		EDB °F (°C)	CFM	Capacity MBtuh		Total Sys KW	Capacity MBtuh		Total Sys KW	Capacity MBtuh		Total Sys KW	Capacity MBtuh		Total Sys KW	Capacity MBtuh		Total Sys KW	Capacity MBtuh		Total Sys KW	Capacity MBtuh		Total Sys KW	
Total	Integ			Total	Integ		Total	Integ		Total	Integ		Total	Integ		Total	Integ		Total	Integ		Total	Integ		
65 (18.3)	1750	17.66	16.25	3.76	23.16	21.31	3.84	29.24	26.84	3.95	35.94	32.60	4.09	43.49	38.10	4.26	52.28	44.7	4.47	60.79	60.79	4.67	70.82	70.82	4.91
	2000	18.08	16.63	3.82	23.63	21.75	3.89	29.77	27.32	3.99	36.54	33.14	4.11	44.35	38.86	4.26	52.93	44.5	4.45	61.57	61.57	4.62	71.85	71.85	4.83
	2250	18.45	16.97	3.89	24.06	22.13	3.95	30.23	27.75	4.04	37.06	33.61	4.15	45.80	40.13	4.31	53.47	45.47	4.45	62.27	62.27	4.60	72.73	72.73	4.79
70 (21.1)	1750	16.61	15.28	3.89	22.18	20.41	3.98	28.31	25.98	4.10	35.03	31.77	4.25	42.48	37.22	4.43	51.67	43.67	4.67	60.02	60.02	4.88	69.83	69.83	5.12
	2000	17.01	15.65	3.95	22.64	20.84	4.03	28.83	26.46	4.14	35.62	32.31	4.27	43.19	37.84	4.43	52.25	44.25	4.64	60.78	60.78	4.82	70.85	70.85	5.04
	2250	17.37	15.98	4.02	23.05	21.21	4.09	29.29	26.88	4.18	36.14	32.77	4.31	43.80	38.38	4.45	52.80	44.80	4.64	61.42	61.42	4.80	71.71	71.71	5.00
75 (23.9)	1750	15.54	14.30	4.03	21.18	19.49	4.13	27.35	25.10	4.26	34.10	30.93	4.42	41.52	36.38	4.61	50.99	42.88	4.88	59.24	59.24	5.09	68.87	68.87	5.35
	2000	15.92	14.65	4.09	21.62	19.89	4.18	27.86	25.57	4.30	34.68	31.45	4.44	42.20	36.98	4.61	51.63	43.48	4.84	59.98	59.98	5.03	69.84	69.84	5.26
	2250	16.27	14.97	4.16	22.03	20.27	4.24	28.31	25.99	4.34	35.19	31.92	4.47	42.78	37.48	4.63	52.15	44.84	4.84	60.64	60.64	5.01	70.69	70.69	5.21

PERFORMANCE DATA (CONT)

LEGEND

- BF — Bypass Factor
- edb — Entering Dry—Bulb
- Ewb — Entering Wet—Bulb
- KW — Total Unit Power Input
- SHC — Sensible Heat Capacity (1000 Btuh)
- TC — Total Capacity (1000 Btuh) (net)
- rh —Relative Humidity

COOLING NOTES:

1. Ratings are net; they account for the effects of the evaporator—fan motor power and heat.
2. Direct interpolation is permissible. Do not extrapolate.
3. The following formulas may be used:

$$t_{ldb} = t_{edb} - \frac{\text{Sensible capacity (Btuh)}}{1.10 \times \text{CFM}}$$

$$t_{lwb} = \text{Wet-bulb temperature corresponding to enthalpy of air leaving evaporator coil } (t_{lwb})$$

$$\text{total capacity (Btuh)}$$

$$h_{lwb} = h_{ewb} - 4.5 \times \text{CFM}$$

Where: h_{ewb} = Enthalpy of air entering evaporator coil

4. The SHC is based on 80° F (26.6° C) edb temperature of air entering evaporator coil. Below 80° F (26.6° C) edb, subtract (corr factor x CFM) from SHC.
- Above 80° F (26.6° C) edb, add (corr factor x CFM) to SHC.
- Correction Factor = $1.10 \times (1 + \text{BF}) \times (\text{edb} - 80)$.

5. Integrated capacity is maximum (instantaneous) capacity less the effect of frost on the outdoor coil and the heat required to defrost it.

Multiplication Factors

HEATER VOLT RATING	VOLTAGE DISTRIBUTION	MULTIPLICATION FACTOR
240	200	0.69
	208	0.75
	230	0.92
	240	1.00
480	460	0.92

Dry Coil Air Delivery* – Horizontal and Downflow Discharge – Sizes 24–60 208/230VAC – 1 Phase

Unit Size	Motor Speed	Wire Color	External Static Pressure (IN. W.C.)																
			0.1	0.2	0.3	0.4	0.5	0.6	0.7	0.8	0.9	1							
24	Low ¹	CFM	669	580	525	423	303	---	---	---	---	---	---	---	---	---	---	---	
		BHP	0.09	0.10	0.11	0.11	0.12	---	---	---	---	---	---	---	---	---	---	---	---
	Med–Low ²	CFM	829	752	680	602	549	455	313	---	---	---	---	---	---	---	---	---	---
		BHP	0.14	0.15	0.15	0.16	0.17	0.17	0.18	---	---	---	---	---	---	---	---	---	---
	Medium ³	CFM	1014	929	884	818	746	683	600	537	405	305	---	---	---	---	---	---	---
		BHP	0.24	0.24	0.24	0.25	0.26	0.26	0.27	0.27	0.27	0.29	0.29	---	---	---	---	---	---
	Med–High	CFM	1041	972	916	850	782	713	631	581	465	340	---	---	---	---	---	---	---
		BHP	0.25	0.26	0.26	0.26	0.26	0.27	0.28	0.29	0.30	0.31	---	---	---	---	---	---	---
	High	CFM	1187	1124	1061	996	930	896	840	776	698	610	---	---	---	---	---	---	---
		BHP	0.36	0.36	0.37	0.37	0.38	0.38	0.39	0.39	0.39	0.40	---	---	---	---	---	---	---
30	Low ¹	CFM	669	580	525	423	303	---	---	---	---	---	---	---	---	---	---	---	
		BHP	0.09	0.10	0.11	0.11	0.12	---	---	---	---	---	---	---	---	---	---	---	---
	Med–Low ³	CFM	829	752	680	602	549	455	313	---	---	---	---	---	---	---	---	---	---
		BHP	0.14	0.15	0.15	0.16	0.17	0.17	0.18	---	---	---	---	---	---	---	---	---	---
	Medium ²	CFM	1014	929	884	818	746	683	600	537	405	305	---	---	---	---	---	---	---
		BHP	0.24	0.24	0.24	0.25	0.26	0.26	0.27	0.27	0.27	0.29	0.29	---	---	---	---	---	---
	Med–High	CFM	1041	972	916	850	782	713	631	581	465	340	---	---	---	---	---	---	---
		BHP	0.25	0.26	0.26	0.26	0.26	0.27	0.28	0.29	0.30	0.31	---	---	---	---	---	---	---
	High	CFM	1187	1124	1061	996	930	896	840	776	698	610	---	---	---	---	---	---	---
		BHP	0.36	0.36	0.37	0.37	0.38	0.38	0.39	0.39	0.39	0.40	---	---	---	---	---	---	---
36	Med–Low ¹	CFM	1170	1094	1027	955	883	870	810	748	680	591	---	---	---	---	---	---	
		BHP	0.19	0.20	0.21	0.22	0.23	0.24	0.24	0.24	0.25	0.26	0.26	---	---	---	---	---	---
	Medium ²	CFM	1292	1246	1183	1124	1059	995	924	877	856	819	---	---	---	---	---	---	---
		BHP	0.25	0.26	0.28	0.29	0.30	0.31	0.32	0.33	0.34	0.34	---	---	---	---	---	---	---
	Med–High	CFM	1311	1225	1199	1145	1081	1015	952	902	885	843	---	---	---	---	---	---	---
		BHP	0.26	0.27	0.28	0.30	0.31	0.32	0.33	0.33	0.35	0.35	---	---	---	---	---	---	---
	High	CFM	1602	1535	1469	1404	1333	1260	1246	1192	1191	1131	---	---	---	---	---	---	---
		BHP	0.46	0.47	0.48	0.50	0.50	0.51	0.52	0.53	0.54	0.55	---	---	---	---	---	---	---
	Low ³	CFM	1001	902	833	777	717	650	575	527	466	419	---	---	---	---	---	---	---
		BHP	0.13	0.13	0.14	0.14	0.15	0.16	0.17	0.18	0.19	0.20	0.20	---	---	---	---	---	---
Med–Low ¹	CFM	1016	950	902	842	783	721	655	590	541	480	---	---	---	---	---	---	---	
	BHP	0.13	0.14	0.15	0.16	0.17	0.18	0.19	0.20	0.21	0.22	---	---	---	---	---	---	---	
Medium ²	CFM	1403	1358	1316	1265	1217	1167	1116	1067	1012	956	---	---	---	---	---	---	---	
	BHP	0.29	0.30	0.31	0.33	0.34	0.35	0.36	0.37	0.38	0.39	---	---	---	---	---	---	---	
Med–High	CFM	1461	1411	1367	1327	1275	1220	1174	1127	1074	1022	---	---	---	---	---	---	---	
	BHP	0.32	0.33	0.35	0.36	0.37	0.38	0.39	0.40	0.41	0.42	---	---	---	---	---	---	---	
High	CFM	1575	1528	1488	1447	1406	1360	1314	1264	1213	1159	---	---	---	---	---	---	---	
	BHP	0.40	0.42	0.43	0.44	0.45	0.46	0.47	0.48	0.49	0.50	---	---	---	---	---	---	---	

Dry Coil Air Delivery* – Horizontal and Downflow Discharge – Sizes 24–60 208/230VAC – 1 Phase (Cont.)

Unit Size	Motor Speed	Wire Color	External Static Pressure (IN. W.C.)									
			0.1	0.2	0.3	0.4	0.5	0.6	0.7	0.8	0.9	1
48	Low ¹	CFM	1378	1344	1295	1260	1216	1179	1135	1087	1035	995
		BHP	0.26	0.27	0.29	0.31	0.31	0.33	0.34	0.36	0.36	0.38
	Med–Low ²	CFM	1696	1671	1631	1607	1574	1539	1507	1463	1432	1393
		BHP	0.45	0.47	0.49	0.50	0.52	0.52	0.54	0.55	0.57	0.58
	Medium ³	CFM	1994	1968	1943	1910	1882	1835	1774	1702	1614	1512
		BHP	0.72	0.73	0.75	0.76	0.78	0.78	0.76	0.73	0.70	0.66
	Med–High	CFM	2054	2013	1986	1964	1919	1854	1779	1695	1605	1498
		BHP	0.77	0.79	0.80	0.82	0.81	0.80	0.76	0.74	0.69	0.65
	High	CFM	2267	2201	2133	2071	1997	1923	1835	1739	1654	1551
		BHP	1.03	1.00	0.97	0.93	0.89	0.86	0.82	0.78	0.74	0.69
60	Low ³	CFM	1330	1277	1232	1191	1147	1103	1060	1004	963	919
		BHP	0.26	0.27	0.29	0.30	0.31	0.32	0.33	0.34	0.36	0.37
	Med–Low ¹	CFM	1475	1436	1399	1351	1317	1270	1236	1188	1152	1105
		BHP	0.35	0.36	0.37	0.38	0.40	0.41	0.42	0.43	0.45	0.45
	Medium ²	CFM	1736	1710	1668	1630	1600	1557	1522	1479	1450	1406
		BHP	0.53	0.54	0.55	0.58	0.59	0.60	0.62	0.63	0.64	0.65
	Med–High	CFM	1935	1909	1867	1836	1808	1766	1696	1619	1535	1454
		BHP	0.71	0.73	0.74	0.76	0.78	0.79	0.77	0.75	0.72	0.68
	High	CFM	2205	2150	2078	2011	1941	1852	1779	1672	1572	1473
		BHP	1.04	1.02	0.99	0.95	0.92	0.87	0.85	0.79	0.75	0.70

* Air delivery values are without air filter and are for dry coil (See Wet Coil Pressure Drop Table).

¹ Factory–shipped heating speed

² Factory–shipped cooling speed

³ Factory–shipped continuous fan speed

NOTE: Ductwork–supplied air filter pressure drop and wet coil pressure drop to obtain external static pressure available for ducting.

Shaded areas indicate speed/static combinations that are not permitted.

Dry Coil Air Delivery CFM* – Horizontal Discharge Sizes 36–60 3–Phase Models Only

Unit	Motor Speed	Wire Color	External Static Pressure (IN. W.C.)									
			0.1	0.2	0.3	0.4	0.5	0.6	0.7	0.8	0.9	
36	Low	Blue	983	848	764	693	612	542	509	450	374	
	Med–Low ¹	Pink	1008	901	838	757	693	618	550	532	471	
	Medium ²	Red	1222	1236	1195	1148	1101	1052	1004	957	916	
42	Med–High	Orange	1311	1242	1219	1161	1098	1032	969	907	841	
	High	Black	1536	1470	1405	1333	1263	1204	1239	1181	1122	
	Low	Blue	952	882	806	746	671	605	530	551	486	
48	Med–Low ¹	Pink	1002	936	875	821	748	687	613	554	565	
	Medium	Red	1255	1210	1145	1074	1008	940	878	895	838	
	Med–High ²	Orange	1335	1267	1246	1176	1109	1049	988	926	872	
60	High	Black	1472	1401	1326	1251	1275	1198	1139	1085	1023	
	Low ¹	Blue	1402	1351	1311	1263	1224	1172	1136	1080	1041	
	Med–Low	Pink	1457	1404	1367	1318	1284	1233	1197	1144	1104	
60	Medium ²	Red	1736	1695	1642	1601	1553	1512	1465	1427	1381	
	Med–High	Orange	2149	2111	2062	2026	1980	1945	1905	1864	1793	
	High	Black	2344	2306	2259	2203	2141	2070	1991	1902	1803	
60	Low ¹	Blue	1445	1389	1341	1281	1236	1189	1139	1072	1027	
	Med–Low	Pink	1678	1635	1602	1558	1513	1474	1438	1404	1349	
	Medium ²	Red	1962	1915	1880	1843	1794	1753	1711	1675	1628	
60	Med–High	Orange	2131	2088	2065	2013	1982	1941	1888	1860	1785	
	High	Black	2461	2409	2339	2286	2192	2140	2062	1968	1874	

² Factory–shipped cooling speed.

NOTE: Duct field–supplied air filter pressure drop and wet coil pressure drop to obtain external static pressure available for ducting.

Shaded areas indicate speed/static combinations that are not permitted for dehumidification speed.

Dry Coil Air Delivery – Downflow Discharge – 36–60 3 Phase Models Only

Unit	Motor Speed	Wire Color	External Static Pressure (IN. W.C.)											
			0.1	0.2	0.3	0.4	0.5	0.6	0.7	0.8	0.9	1.0		
36	Low	Blue	CFM	983	848	764	693	612	542	509	450	374	---	
			WATTS	115	107	113	123	128	138	144	154	159	---	
	Med–Low ¹	Pink	BHP	0.12	0.11	0.12	0.13	0.14	0.15	0.15	0.15	0.17	---	
			CFM	1008	901	838	757	693	618	550	532	471	402	
			WATTS	123	121	132	137	148	154	164	170	181	185	
			BHP	0.13	0.13	0.14	0.15	0.16	0.17	0.18	0.18	0.19	0.20	
		Medium ²	Red	CFM	1222	1236	1195	1148	1101	1052	1004	957	916	868
				WATTS	233	221	232	244	251	264	275	285	291	304
			Orange	BHP	0.25	0.24	0.25	0.26	0.27	0.28	0.29	0.31	0.31	0.33
				CFM	1311	1242	1219	1161	1098	1032	969	907	841	859
	Med–High	Black	WATTS	256	270	283	289	301	313	320	331	343	349	
			BHP	0.27	0.29	0.30	0.31	0.32	0.34	0.34	0.35	0.37	0.37	
	High	Black	CFM	1536	1470	1405	1333	1263	1204	1239	1181	1122	1055	
			WATTS	411	423	429	441	453	464	473	477	488	489	
	Low	Blue	BHP	0.44	0.45	0.46	0.47	0.49	0.50	0.51	0.51	0.52	0.52	
			CFM	952	882	806	746	671	605	530	551	486	435	
			WATTS	124	134	140	150	156	166	171	182	188	198	
			BHP	0.13	0.14	0.15	0.16	0.17	0.18	0.18	0.20	0.20	0.21	
	Med–Low ¹	Pink	CFM	1002	936	875	821	748	687	613	554	565	518	
			WATTS	144	155	161	171	176	187	193	203	209	220	
	Medium	Red	BHP	0.15	0.17	0.17	0.18	0.19	0.20	0.21	0.22	0.22	0.24	
			CFM	1255	1210	1145	1074	1008	940	878	895	838	785	
	Med–High ²	Orange	WATTS	249	272	284	292	305	319	320	329	336	347	
			BHP	0.27	0.29	0.30	0.31	0.33	0.34	0.34	0.35	0.36	0.37	
	High	Black	CFM	1335	1267	1246	1176	1109	1049	988	926	872	891	
			WATTS	311	323	330	342	356	367	378	385	395	403	
			BHP	0.33	0.35	0.35	0.37	0.38	0.39	0.41	0.41	0.42	0.43	
			CFM	1472	1401	1326	1251	1275	1198	1139	1085	1023	961	
			WATTS	401	414	426	440	471	462	473	478	486	491	
			BHP	0.43	0.44	0.46	0.47	0.51	0.50	0.51	0.51	0.52	0.53	

Dry Coil Air Delivery – Downflow Discharge – Sizes 36–60 3 Phase Models Only (Cont.)

Unit	Motor Speed	Wire Color	External Static Pressure (IN. W.C.)									
			0.1	0.2	0.3	0.4	0.5	0.6	0.7	0.8	0.9	1.0
48	Low ¹	CFM	1503	1457	1423	1374	1330	1287	1241	1199	1153	1111
		WATTS	225	233	246	254	269	282	292	307	314	329
	Med–Low	BHP	0.24	0.25	0.26	0.27	0.29	0.30	0.31	0.31	0.33	0.35
		CFM	1556	1508	1461	1432	1388	1346	1302	1256	1221	1168
		WATTS	244	261	268	281	290	305	319	330	345	353
		BHP	0.26	0.28	0.29	0.30	0.31	0.33	0.34	0.35	0.37	0.38
	Medium ²	CFM	1861	1822	1786	1758	1716	1688	1660	1619	1583	1539
		WATTS	400	417	426	441	452	467	482	492	507	519
		BHP	0.43	0.45	0.46	0.47	0.48	0.50	0.52	0.53	0.54	0.56
		CFM	2319	2291	2255	2230	2193	2166	2118	2057	1992	1887
Med–High	WATTS	758	769	787	799	808	823	822	805	780	737	
	BHP	0.81	0.82	0.84	0.86	0.87	0.88	0.88	0.86	0.84	0.79	
High	CFM	2532	2487	2444	2391	2330	2259	2179	2111	2033	1949	
	WATTS	1014	1022	1015	994	965	935	898	858	823	786	
	BHP	1.09	1.10	1.09	1.07	1.03	1.00	0.96	0.92	0.88	0.84	
	CFM	1479	1436	1387	1346	1298	1253	1206	1160	1114	1061	
Low ¹	WATTS	224	239	247	262	270	284	300	307	319	330	
	BHP	0.24	0.26	0.26	0.28	0.29	0.30	0.32	0.33	0.34	0.35	
Med–Low	CFM	1841	1796	1761	1724	1690	1651	1616	1578	1527	1478	
	WATTS	425	434	453	460	476	485	501	508	525	542	
	BHP	0.46	0.47	0.49	0.49	0.51	0.52	0.54	0.54	0.56	0.58	
	CFM	1944	1913	1872	1838	1801	1771	1731	1698	1655	1613	
Medium ²	WATTS	486	501	511	529	537	554	565	578	595	603	
	BHP	0.52	0.54	0.55	0.57	0.58	0.59	0.61	0.62	0.64	0.65	
Med–High	CFM	2178	2148	2105	2073	2036	2002	1967	1919	1845	1751	
	WATTS	674	691	703	717	733	743	758	754	734	701	
	BHP	0.72	0.74	0.75	0.77	0.79	0.80	0.81	0.81	0.79	0.75	
	CFM	2480	2432	2375	2322	2236	2161	2085	2006	1917	1808	
High	WATTS	1029	1012	995	975	941	908	869	836	796	751	
	BHP	1.10	1.09	1.07	1.05	1.01	0.97	0.93	0.90	0.85	0.81	

** Air delivery values are without air filter and are for dry coil (See Wet Coil Pressure Drop table).

¹ Factory–shipped heating speed

² Factory–shipped cooling speed

Note: Ductwork field–supplied air filter pressure drop and wet coil pressure drop to obtain external static pressure available for ducting.

Shaded areas indicate speed/static combinations that are not permitted for dehumidification speed.

PERFORMANCE DATA (CONT)
Filter Pressure Drop Table (IN. W.C.)

FILTER SIZE IN. (MM)	COOLING TONS	STANDARD CFM (SCFM)																
		600	700	800	900	1000	1100	1200	1300	1400	1500	1600	1700	1800	1900	2000	2100	2200
600-1400 CFM 12x20x1+12x20x1 (305x508x25+305x508x25)	2.0,	0.03	0.04	0.05	0.06	0.06	0.07	0.07	0.08	0.08	-	-	-	-	-	-	-	-
	2.5	-	-	0.06	0.07	0.08	0.08	0.09	0.09	0.10	0.10	0.10	0.11	0.11	0.12	0.12	0.12	0.12
1200-1800CFM 16x24x1+14x24x1 (406x610x25+356x610x25)	3.0,	-	-	0.06	0.07	0.08	0.08	0.09	0.09	0.10	0.10	0.11	0.11	0.12	0.12	0.12	0.12	0.12
	3.5,	-	-	0.06	0.07	0.08	0.08	0.09	0.09	0.10	0.10	0.11	0.11	0.12	0.12	0.12	0.12	0.12
1500-2200CFM 16x24x1+18x24x1 (406x610x25+457x610x25)	4.0	-	-	0.05	0.06	0.06	0.07	0.07	0.08	0.08	0.09	0.09	0.10	0.10	0.11	0.11	0.11	0.11
	5.0	-	-	0.05	0.06	0.06	0.07	0.07	0.08	0.08	0.09	0.09	0.10	0.10	0.11	0.11	0.11	0.11

Wet Coil Pressure Drop (IN. W.C.)

UNIT SIZE	STANDARD CFM (SCFM)																
	600	700	800	900	1000	1100	1200	1300	1400	1500	1600	1700	1800	1900	2000	2100	2200
24	0.03	0.04	0.04	0.05	0.06	0.06	0.07	0.08	0.11								
30				0.05	0.06	0.07	0.08	0.11									
36				0.06	0.06	0.09	0.10	0.11	0.14								
42				0.06	0.05	0.05	0.06	0.07	0.08	0.08	0.09	0.09	0.11				
48				0.06	0.04	0.04	0.04	0.06	0.09	0.10	0.10	0.11	0.12	0.13	0.14		
60								0.06	0.09	0.06	0.07	0.07	0.08	0.09	0.10	0.12	0.13

Economizer with 1-in. Filter Pressure Drop (IN. W.C.)

FILTER SIZE IN. (MM)	COOLING TONS	STANDARD CFM (SCFM)																
		600	700	800	900	1000	1100	1200	1300	1400	1500	1600	1700	1800	1900	2000	2100	2200
600-1400 CFM 12x20x1+12x20x1 (305x508x25+305x508x25)	2.0,	-	-	0.08	0.09	0.10	0.10	0.11	0.11	0.13	0.14	-	-	-	-	-	-	-
	2.5	-	-	0.08	0.09	0.10	0.10	0.11	0.11	0.13	0.14	-	-	-	-	-	-	-
1200-1800CFM 16x24x1+14x24x1 (406x610x25+356x610x25)	3.0,	-	-	0.08	0.09	0.10	0.10	0.11	0.11	0.13	0.14	-	-	-	-	-	-	-
	3.5,	-	-	0.08	0.09	0.10	0.10	0.11	0.11	0.13	0.14	-	-	-	-	-	-	-
1500-2200CFM 16x24x1+18x24x1 (406x610x25+457x610x25)	4.0	-	-	0.08	0.09	0.10	0.10	0.11	0.11	0.13	0.14	-	-	-	-	-	-	-
	5.0	-	-	0.08	0.09	0.10	0.10	0.11	0.11	0.13	0.14	-	-	-	-	-	-	-

**Electric Heat Pressure Drop Table (IN. W.C.)
Small Cabinet: 24-30**

STATIC	STANDARD CFM (SCFM)																	
	500	600	700	800	900	1000	1100	1200	1300	1400	1500	1600	1700	1800	1900	2000	2100	2200
5kw	0.00	0.00	0.00	0.00	0.00	0.00	0.00	0.00	0.00	0.00	0.00	0.00	0.00	0.02	0.04	0.06	0.07	0.07
7.5 kw	0.00	0.00	0.00	0.00	0.00	0.00	0.00	0.00	0.00	0.02	0.02	0.03	0.03	0.05	0.07	0.08	0.08	0.09
10 kw	0.00	0.00	0.00	0.00	0.00	0.00	0.00	0.00	0.00	0.04	0.04	0.06	0.06	0.07	0.09	0.10	0.10	0.11
15 kw	0.00	0.00	0.00	0.00	0.02	0.04	0.04	0.06	0.06	0.08	0.08	0.10	0.10	0.12	0.14	0.16	0.16	0.18
20 kw	0.00	0.00	0.02	0.04	0.04	0.06	0.06	0.08	0.08	0.09	0.11	0.11	0.13	0.15	0.17	0.17	0.19	0.19

**Electric Heat Pressure Drop Table (IN. W.C.)
Large Cabinet 36-60**

STATIC	STANDARD CFM (SCFM)															
	1100	1200	1300	1400	1500	1600	1700	1800	1900	2000	2100	2200	2300	2400	2500	
5kw	0.00	0.00	0.00	0.01	0.02	0.03	0.04	0.05	0.06	0.07	0.08	0.09	0.10	0.11	0.12	
7.5 kw	0.00	0.00	0.01	0.02	0.03	0.04	0.05	0.06	0.07	0.08	0.09	0.10	0.11	0.12	0.13	
10 kw	0.00	0.00	0.01	0.02	0.03	0.04	0.05	0.06	0.07	0.08	0.09	0.10	0.11	0.12	0.13	
15 kw	0.00	0.02	0.03	0.04	0.05	0.06	0.07	0.08	0.09	0.10	0.11	0.12	0.13	0.14	0.15	
20 kw	0.02	0.03	0.04	0.05	0.06	0.07	0.08	0.09	0.10	0.11	0.12	0.13	0.14	0.15	0.16	

TYPICAL PIPING AND WIRING

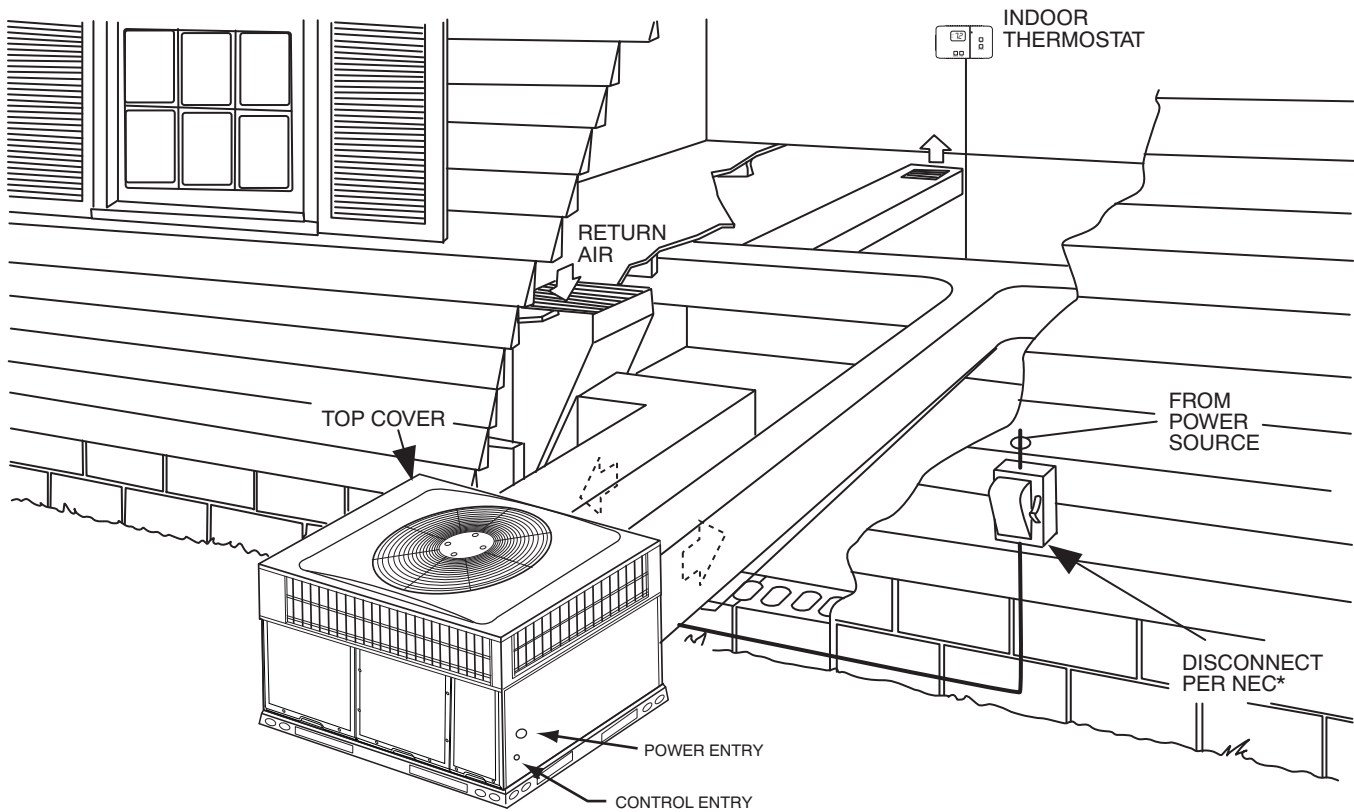

*NEC - National Electrical Code

APPLICATION DATA

Condensate trap — A 2-in. (51 mm) condensate trap must be field supplied.

Ductwork — Secure downflow discharge ductwork to roof curb. For horizontal discharge applications, attach ductwork to unit with flanges.

To convert a unit to downflow discharge — Units are equipped with factory-installed inserts in the downflow openings. Removal of the inserts is similar to removing an electrical knock-out. Units installed in horizontal discharge orientation do not require duct covers.

Maximum cooling airflow — To minimize the possibility of condensate blow-off from the evaporator, airflow through the units should not exceed 450 CFM per ton.

Minimum cooling airflow — Minimum cooling airflow is 350 CFM per ton in cooling mode. Airflow can be lower in certain modes when humidity removal is an issue however, low airflow could result in indoor coil freezing and/or refrigerant floodback.

Minimum ambient cooling operation temperature — All standard units have a minimum ambient cooling operating temperature of 40°F (4.4°C). With accessory low ambient temperature kit, units can operate at temperatures down to 0°F (17.8°C).

Maximum operating outdoor air temperature for cooling is 125°F (51.7°C).

BALANCE POINT WORKSHEET

BUILDING HEAT LOSS, UNIT INTEGRATED HEATING CAPACITY, MBTUH

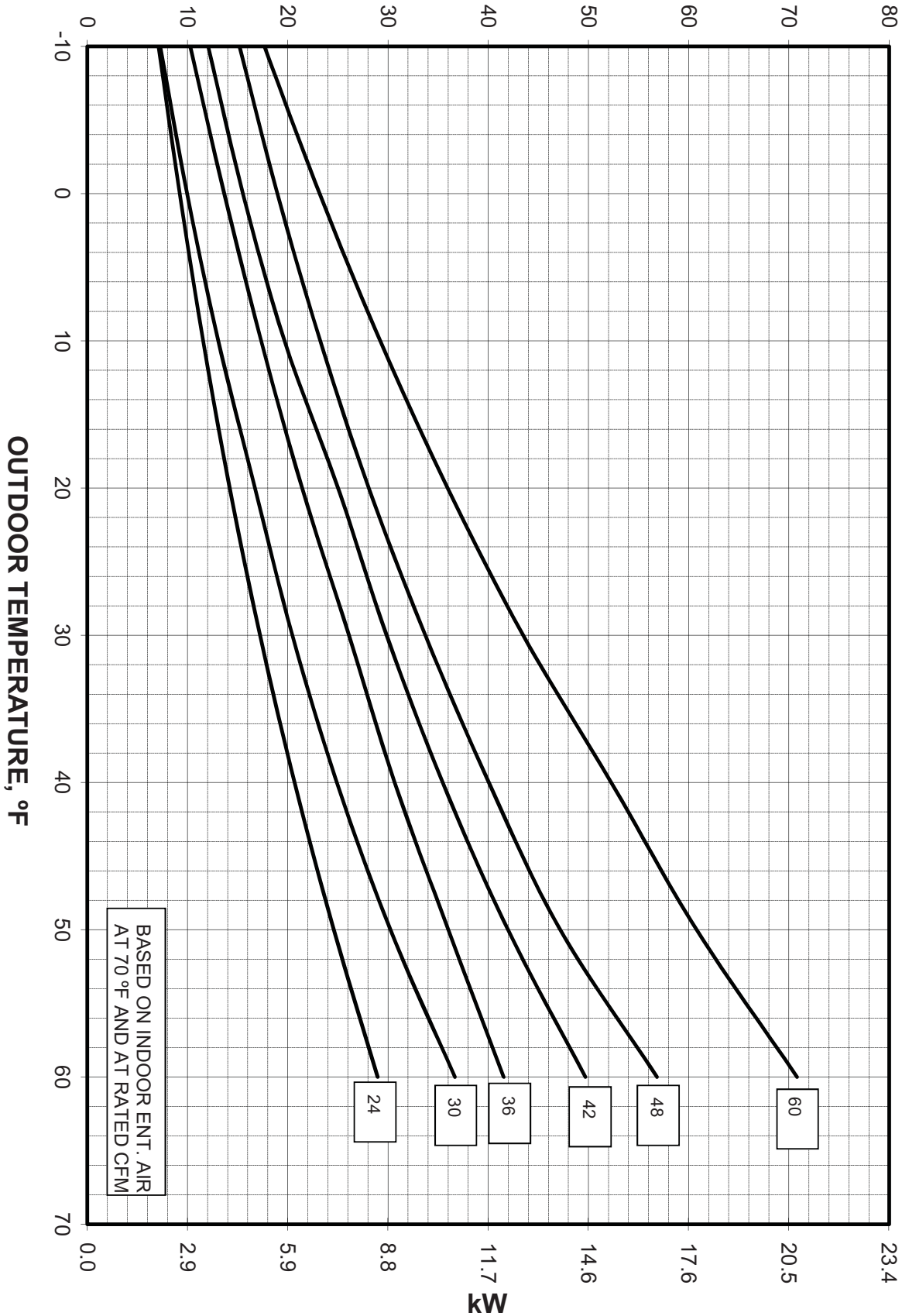

BALANCE POINT WORKSHEET

A150725

ELECTRICAL DATA

MOD-EL	NOMINAL V-PH-HZ	VOLTAGE RANGE		COMPRES-SOR		OFM	IFM	NOMINAL ELECTRIC HEAT	POWER SUPPLY			
		MIN	MAX	RLA	LRA	FLA	FLA		kW	FLA	MCA	MOCP
24	208/230-1-60	197	253	13.5	58.3	0.6	3.8	-/-	-/-	21.3	30	
								3.8/5	18.1/20.8	43.9/47.3	45/50	
								5.4/7.2	25.9/30	53.7/58.8	60/60	
								7.5/10	36.1/41.7	66.4/73.4	70/80	
30	208/230-1-60	197	253	14.1	73	0.7	3.8	-/-	-/-	22.1	35	
								3.8/5	18.1/20.8	44.8/48.1	45/50	
								5.4/7.2	25.9/30	54.5/59.6	60/60	
								7.5/10	36.1/41.7	67.3/74.3	70/80	
36	208/230-1-60	197	253	16.7	79	1	3.8	-/-	-/-	25.8	40	
								3.8/5	18.1/20.8	48.4/51.7	50/60	
								5.4/7.2	25.9/30	58.1/63.2	60/70	
								7.5/10	36.1/41.7	70.9/77.9	80/80	
	208/230-3-60	197	253	10.4	73	1	4.1	11.3/15	54.2/62.5	89.9/100.3	90/110	
								-/-	-/-	18.2	25	
								3.8/5	10.4/12	31.2/33.2	35/35	
								7.5/10	20.8/24.1	44.2/48.3	45/50	
	460-3-60	414	506	5.8	38	0.5	3.2	11.3/15	31.2/36.1	57.2/63.3	60/70	
								-/-	-/-	11	15	
								10	12/12	26/26	30/30	
								15	18/18	33.5/33.5	35/35	
42	208/230-1-60	197	253	19.3	112	1	3.8	-/-	-/-	29	45	
								3.8/5	18.1/20.8	51.6/55	60/60	
								5.4/7.2	25.9/30	61.4/66.5	70/70	
								7.5/10	36.1/41.7	74.1/81.1	80/90	
	208/230-3-60	197	253	13.5	88	1	4.1	11.3/15	54.2/62.5	96.7/107.1	100/110	
								15/20	72.2/83.3	119.2/133.1	125/150	
								-/-	-/-	22.1	35	
								3.8/5	10.4/12	35/37	35/40	
	460-3-60	414	506	6	44	0.5	3.2	7.5/10	20.8/24.1	48/52.2	50/60	
								11.3/15	31.2/36.1	61/67.2	70/70	
								15/20	41.4/47.9	73.8/81.9	80/90	
								-/-	-/-	11.2	15	
48	208/230-1-60	197	253	19.6	130	1.1	7.6	10	12/12	26.2/26.2	30/30	
								15	18/18	33.7/33.7	35/35	
								20	24.1/24.1	41.4/41.4	45/45	
								-/-	-/-	33.2	50	
	208/230-3-60	197	253	13.7	83.1	1	7.6	3.8/5	18.1/20.8	55.8/59.2	60/60	
								5.4/7.2	25.9/30	65.5/70.7	70/80	
								7.5/10	36.1/41.7	78.3/85.3	80/90	
								11.3/15	54.2/62.5	100.9/111.3	110/125	
	460-3-60	414	506	6.2	41	0.5	4	15/20	72.2/83.3	123.4/137.3	125/150	
								-/-	-----	25.8	35	
								3.8/5	10.4/12	38.8/40.8	40/45	
								7.5/10	20.8/24.1	51.8/55.9	60/60	

ELECTRICAL DATA (CONT)

MOD-EL	NOMINAL V-PH-HZ	VOLTAGE RANGE		COMPRES-SOR		OFM	IFM	NOMINAL ELECTRIC HEAT	POWER SUPPLY		
		MIN	MAX	RLA	LRA	FLA	FLA	kW	FLA	MCA	MOCP
60	208/230-1-60	197	253	24.4	144.2	1.3	7.7	-/-	-/-	39.5	60
								3.8/5	18.1/20.8	62.1/65.5	70/70
								5.4/7.2	25.9/30	71.9/77	80/80
								7.5/10	36.1/41.7	84.6/91.6	90/100
								11.3/15	54.2/62.5	107.3/117.6	110/125
	15/20	72.2/83.3	129.8/143.6	150/150							
	208/230-3-60	197	253	16	110	1	7.6	-/-	-/-	28.7	40
								3.8/5	10.4/12	41.7/43.7	45/45
								7.5/10	20.8/24.1	54.7/58.8	60/60
								11.3/15	31.2/36.1	67.7/73.8	70/80
								15/20	41.4/47.9	80.4/88.5	90/90
	460-3-60	414	506	7.8	52	0.5	4	-/-	-/-	14.3	20
								10	12/12	29.3/29.3	30/30
								15	18/18	36.8/36.8	40/40
								20	24.1/24.1	44.4/44.4	45/45

See Legend and Notes.

LEGEND

- FLA - Full Load Amps
- IFM - Indoor Fan Motor
- LRA - Locked Rotor Amps
- MCA - Minimum Circuit Amps
- MOCP - Maximum Over Current Protection
- OFM - Outdoor Fan Motor
- RLA - Rated Load Amps

NOTES:

- In compliance with NEC (National Electrical Code) requirements for multimotor and combination load equipment (refer to NEC Articles 430 and 440), the overcurrent protective device for the unit shall be Power Supply fuse or circuit breaker.
- Minimum wire size is based on 60 C copper wire. If other than 60 C wire is used, or if length exceeds wire length in table, determine size from NEC.
- Unbalanced 3-Phase Supply Voltage
Never operate a motor where a phase imbalance in supply voltage is greater than 2%. Use the following formula to determine the percentage of voltage imbalance

$$\% \text{ Voltage imbalance} = 100 \times \frac{\text{max voltage deviation from average voltage}}{\text{average voltage}}$$

EXAMPLE: Supply voltage is 230-3-60.

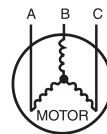

- AB = 228 v
- BC = 231 v
- AC = 227 v

$$\begin{aligned} \text{Average Voltage} &= \frac{228 + 231 + 227}{3} \\ &= \frac{686}{3} \\ &= 229 \end{aligned}$$

Determine maximum deviation from average voltage.

- (AB) 229 - 228 = 1 v
- (BC) 231 - 229 = 2 v
- (AC) 229 - 227 = 2 v

Maximum deviation is 2 v.

Determine percent of voltage imbalance

$$\begin{aligned} \% \text{ Voltage Imbalance} &= 100 \times \frac{2}{229} \\ &= 0.8\% \end{aligned}$$

This amount of phase imbalance is satisfactory as it is below the maximum allowable 2%.

IMPORTANT: If the supply voltage phase imbalance is more than 2%, contact your local electric utility company immediately.

A09604

TYPICAL CONNECTION WIRING SCHEMATIC – 208/230-1-60

CONNECTION WIRING DIAGRAM

DANGER: ELECTRICAL SHOCK HAZARD DISCONNECT POWER BEFORE SERVICING

SCHEMATIC 208/230V-1-60

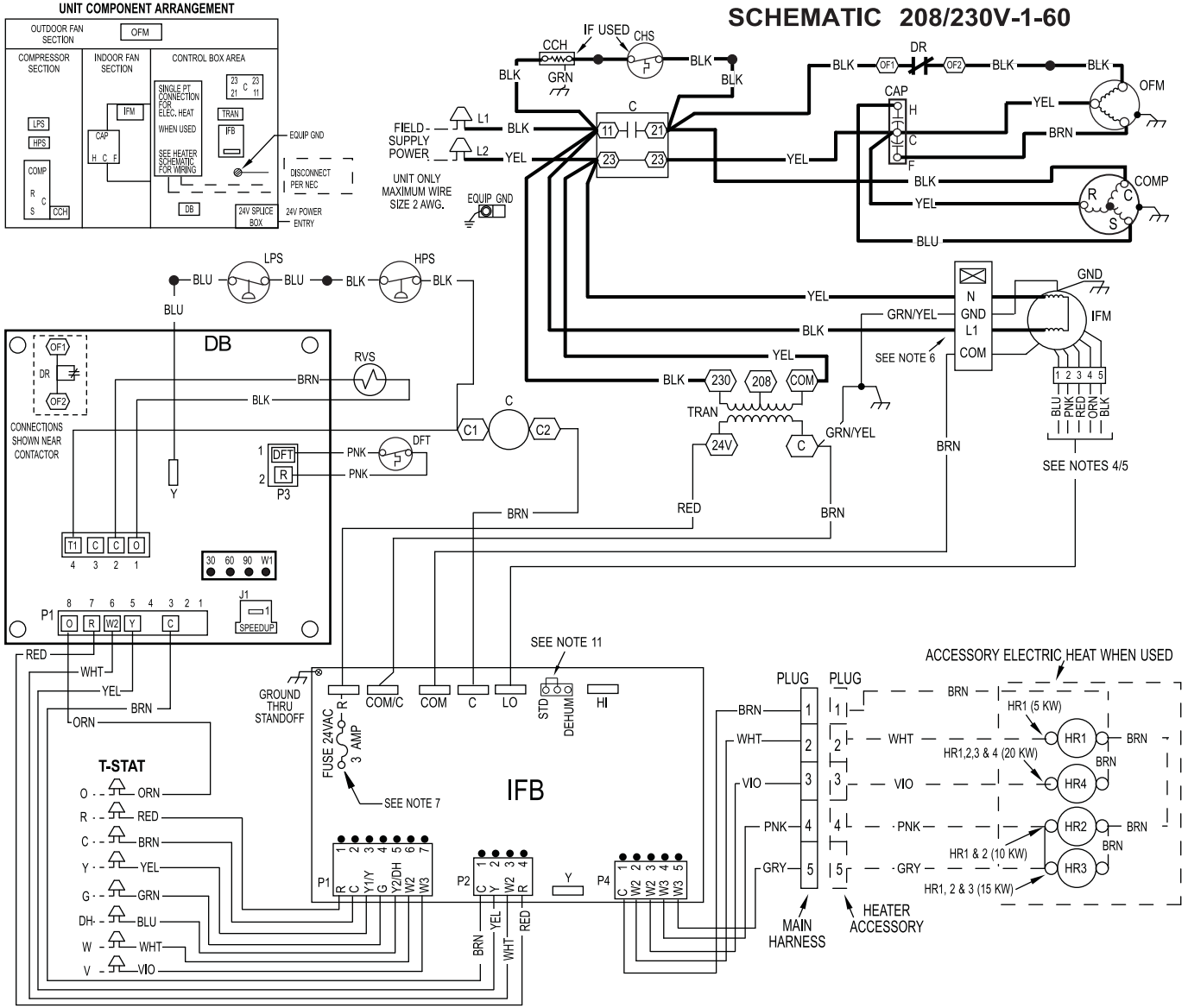

NOTES:

- IF ANY OF THE ORIGINAL WIRES FURNISHED ARE REPLACED IT MUST BE REPLACED WITH THE SAME OR ITS EQUIVALENT.
- SEE PRE SALE LITERATURE FOR THERMOSTATS.
- USE 75 DEGREE C COPPER CONDUCTORS FOR FIELD INSTALLATION.
- REFER TO INSTALLATION INSTRUCTIONS FOR CORRECT SPEED SELECTION FOR IFM.
- RELOCATION OF SPEED TAPS MAY BE REQUIRED WHEN USING FIELD INSTALLED ELECTRIC HEATERS. CONSULT INSTALLATION INSTRUCTIONS TO DETERMINE CORRECT SPEED TAP SETTING.
- "DO NOT DISCONNECT PLUG UNDER LOAD".
- THIS FUSE IS MANUFACTURED BY LITTLE FUSE, P/N 287003.
- N.E.C. CLASS 2, 24V.
- UNIT FACTORY - SHIPPED IN STD MODE.
- CCH NOT USED ON ALL UNITS.
- DEHUM FEATURE CANNOT BE USED WHEN ECONOMIZER IS INSTALLED. UNIT FACTORY - SHIPPED IN STD MODE.

LEGEND

	FIELD SPLICE		TERMINAL (UNMARKED)		SPLICE		SPLICE (MARKED)		FACTORY LO VOLTAGE		FIELD CONTROL WIRING		FIELD POWER WIRING		ACCESSORY OR OPTIONAL WIRING		FACTORY HI VOLTAGE
	FIELD SPLICE		TERMINAL (MARKED)		TERMINAL (UNMARKED)		SPLICE (MARKED)		FACTORY LO VOLTAGE		FIELD CONTROL WIRING		FIELD POWER WIRING		ACCESSORY OR OPTIONAL WIRING		FACTORY HI VOLTAGE
	FIELD SPLICE		TERMINAL (MARKED)		TERMINAL (UNMARKED)		SPLICE (MARKED)		FACTORY LO VOLTAGE		FIELD CONTROL WIRING		FIELD POWER WIRING		ACCESSORY OR OPTIONAL WIRING		FACTORY HI VOLTAGE

A150518

TYPICAL LADDER WIRING SCHEMATIC – 208/230–1–60

LADDER WIRING DIAGRAM

DANGER: ELECTRICAL SHOCK HAZARD DISCONNECT POWER BEFORE SERVICING

DEFROST TIMING SELECTION

FIELD SELECTABLE OPTIONS FOR TIME PERIOD BETWEEN DEFROST CYCLES (MINUTES)
FACTORY DEFROST SETTING IS 60 MIN.

SPEED UP JUMPERED TEST PINS (USE METAL OBJECT) FIELD SPEED-UP CYCLE

1. DFT MUST BE CLOSED TO INITIATE DEFROST CYCLE. IF NECESSARY, REMOVE DFT CONNECTION BEFORE PLACING JUMPER ACROSS DFT PINS.
2. AT THE SAME TIME DFT CLOSED, JUMPER "SPEED UP" PINS WITH SMALL SCREW DRIVER UNTIL DEFROST IS INITIATED. THEN REMOVE SCREW DRIVER.
3. SHORTED "SPEED UP" PINS WILL SPEED UP TIMER BY A FACTOR OF 256.

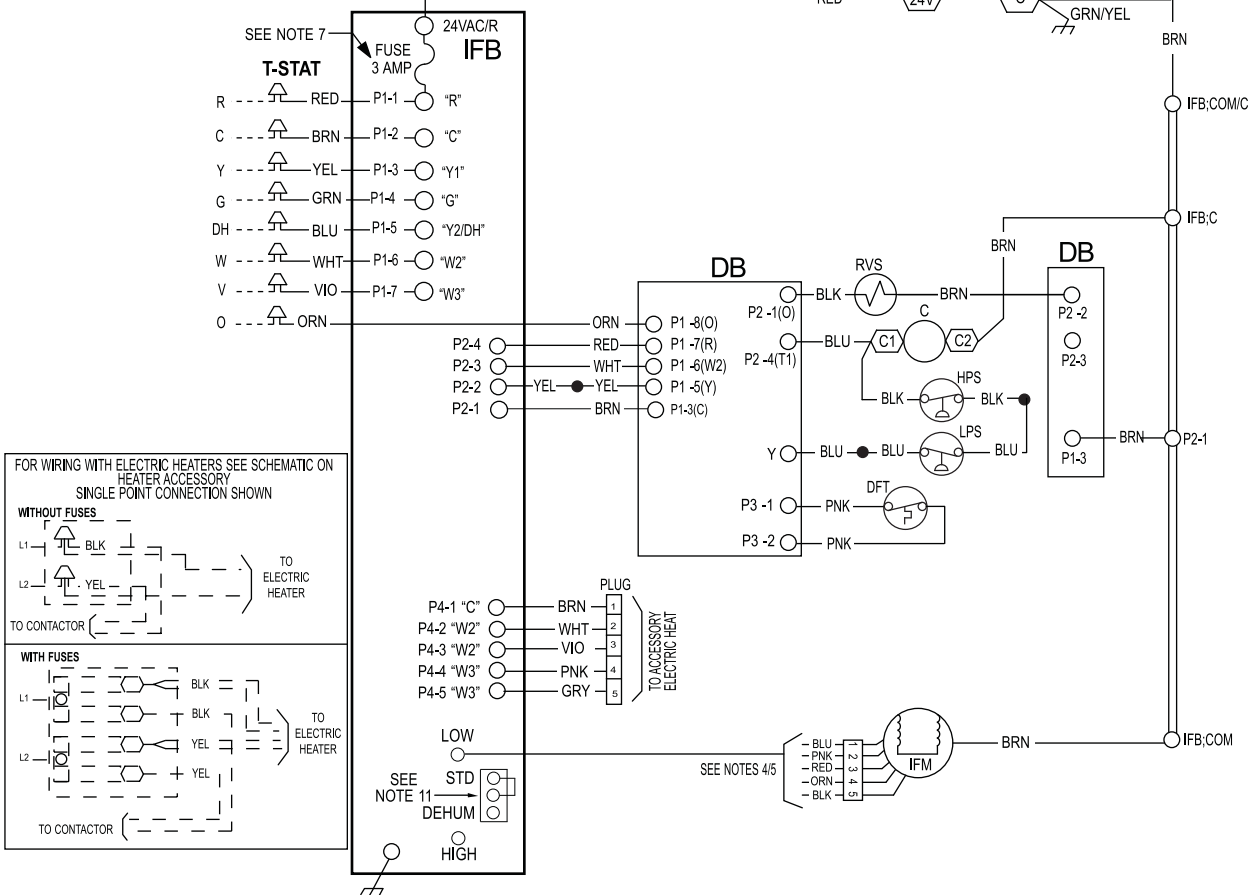
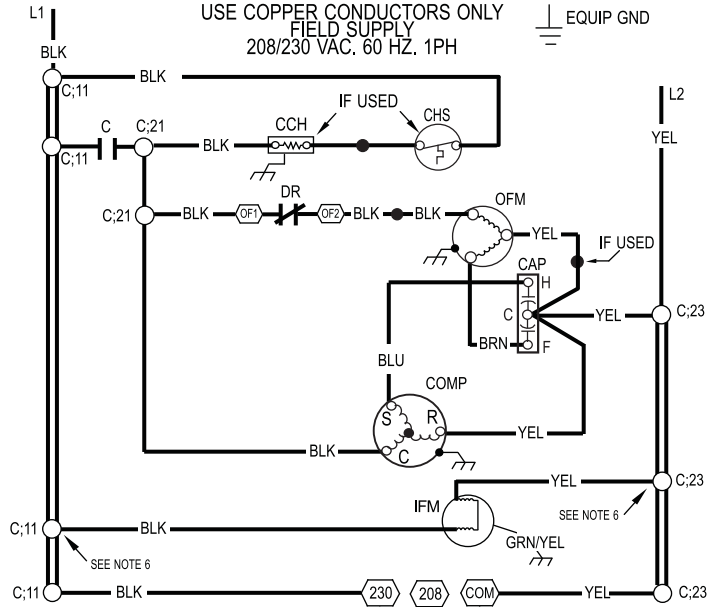

50VT500481 REV.



50VT500481 REV. -

A150519

TYPICAL CONNECTION WIRING SCHEMATIC - 208/230-3-60

CONNECTION WIRING DIAGRAM DANGER: ELECTRICAL SHOCK HAZARD DISCONNECT POWER BEFORE SERVICING

SCHEMATIC 208/230V-3-60

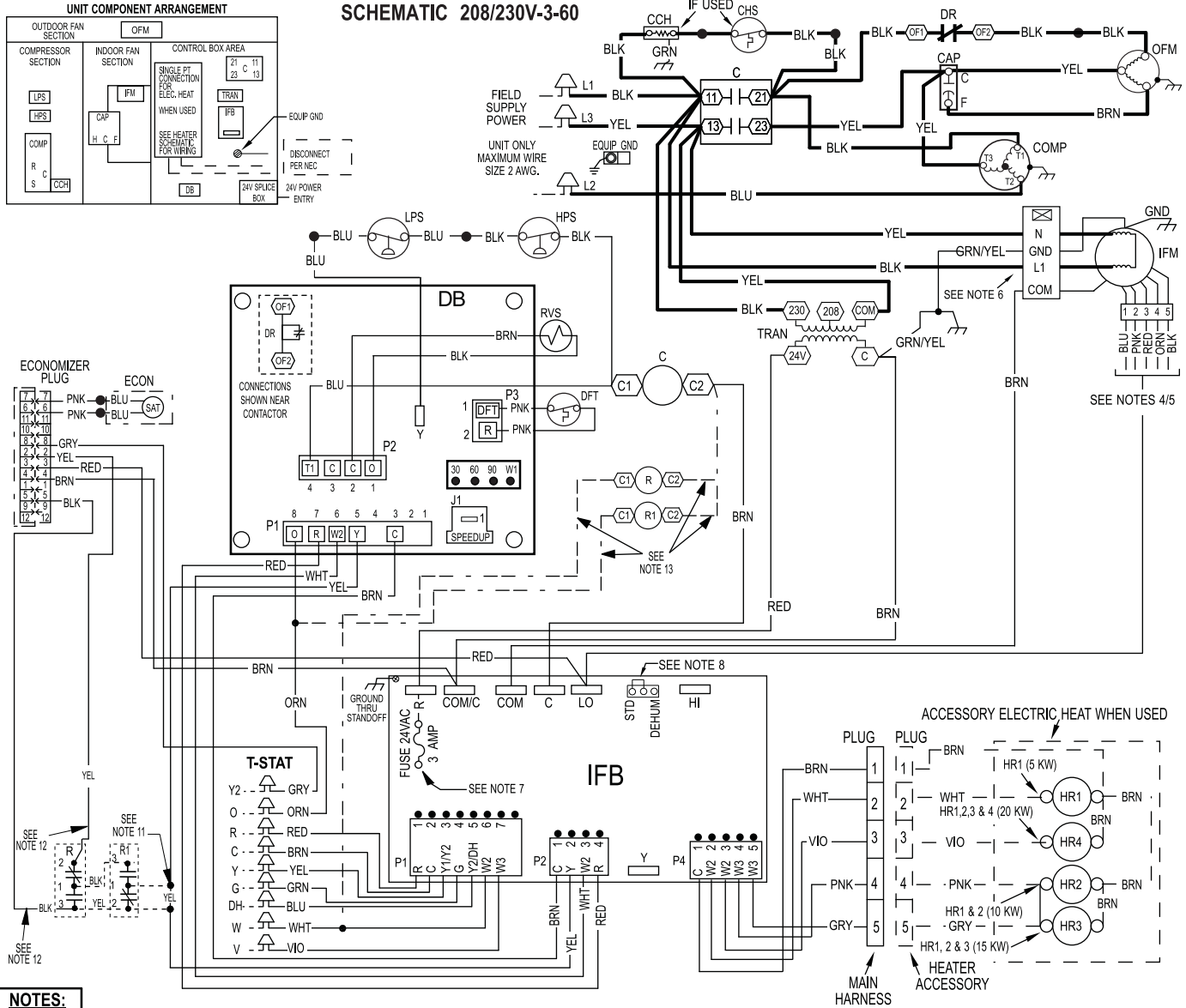

NOTES:

- IF ANY OF THE ORIGINAL WIRES FURNISHED ARE REPLACED IT MUST BE REPLACED WITH THE SAME OR ITS EQUIVALENT.
- SEE PRE SALE LITERATURE FOR THERMOSTATS.
- USE 75 DEGREES C COPPER CONDUCTORS FOR FIELD INSTALLATION.
- REFER TO INSTALLATION INSTRUCTIONS FOR CORRECT SPEED SELECTION FOR IFM.
- RELOCATION OF SPEED TAPS MAY BE REQUIRED WHEN USING FIELD INSTALLED ELECTRIC HEATERS. CONSULT INSTALLATION INSTRUCTIONS TO DETERMINE CORRECT SPEED TAP SETTING.
- "DO NOT DISCONNECT PLUG UNDER LOAD".
- THIS FUSE IS MANUFACTURED BY LITTLE FUSE, P/N 287003.
- DEHUM FEATURE CANNOT BE USED WHEN ECONOMIZER IS INSTALLED. UNIT FACTORY - SHIPPED IN STD MODE.
- N.E.C. CLASS 2, 24V.
- CCH NOT USED ON ALL UNITS.
- REMOVE YELLOW SPLICE WHEN ECONOMIZER AND ECONOMIZER RELAYS ARE USED AND CONNECT TO RELAY R1 AS SHOWN.
- WHEN ECONOMIZER AND ECONOMIZER RELAYS ARE USED CONNECT THE YELLOW AND BLACK WIRES TO RELAY "R" AS SHOWN. RELAY KIT REQUIRED WITH ECONOMIZER AND HEAT PUMP / DUAL FUEL UNITS.
- WHEN ECONOMIZER AND ECONOMIZER RELAYS ARE USED, INSTALL WIRES AS SHOWN ONTO THE COILS OF RELAY R AND RELAY R1.

LEGEND

	FIELD SPLICE	C	CONTACTOR	HR	HEATER RELAY
	TERMINAL (MARKED)	CAP	CAPACITOR	IFB	INDOOR FAN BOARD
	TERMINAL (UNMARKED)	CCH	CRANK CASE HEATER	IFM	INDOOR FAN MOTOR
	SPLICE	COMP	COMPRESSOR MOTOR	LPS	LOW PRESSURE SWITCH
	SPLICE (MARKED)	DB	DEFROST BOARD	OFM	OUTDOOR FAN MOTOR
	FACTORY LO VOLTAGE	DH	DEHUMIDIFICATION MODE	RVS	REVERSING VALVE
	FIELD CONTROL WIRING	DFT	DEFROST TEMPERATURE SWITCH	STD	STANDARD MODE
	FIELD POWER WIRING	DEHUM	DEHUMIDIFICATION MODE SWITCH	TRAN	TRANSFORMER
	ACCESSORY OR OPTIONAL WIRING	T-STAT	THERMOSTAT		
	FACTORY HI VOLTAGE				

TYPICAL LADDER WIRING SCHEMATIC - 208/230-3-60

LADDER WIRING DIAGRAM

DANGER: ELECTRICAL SHOCK HAZARD DISCONNECT POWER BEFORE SERVICING

DEFROST TIMING SELECTION

FIELD SELECTABLE OPTIONS FOR TIME PERIOD BETWEEN DEFROST CYCLES (MINUTES).
FACTORY DEFROST SETTING IS 60 MIN.

SPEED UP [] [] JUMPERED TEST PINS (USE METAL OBJECT) FIELD SPEED-UP CYCLE

1. DFT MUST BE CLOSED TO INITIATE DEFROST CYCLE. IF NECESSARY, REMOVE DFT CONNECTION BEFORE PLACING JUMPER ACROSS DFT PINS.
2. AT THE SAME TIME DFT CLOSED, JUMPER "SPEED UP" PINS WITH SMALL SCREW DRIVER UNTIL DEFROST IS INITIATED. THEN REMOVE SCREW DRIVER.
3. SHORTED "SPEED UP" PINS WILL SPEED UP TIMER BY A FACTOR OF 256.

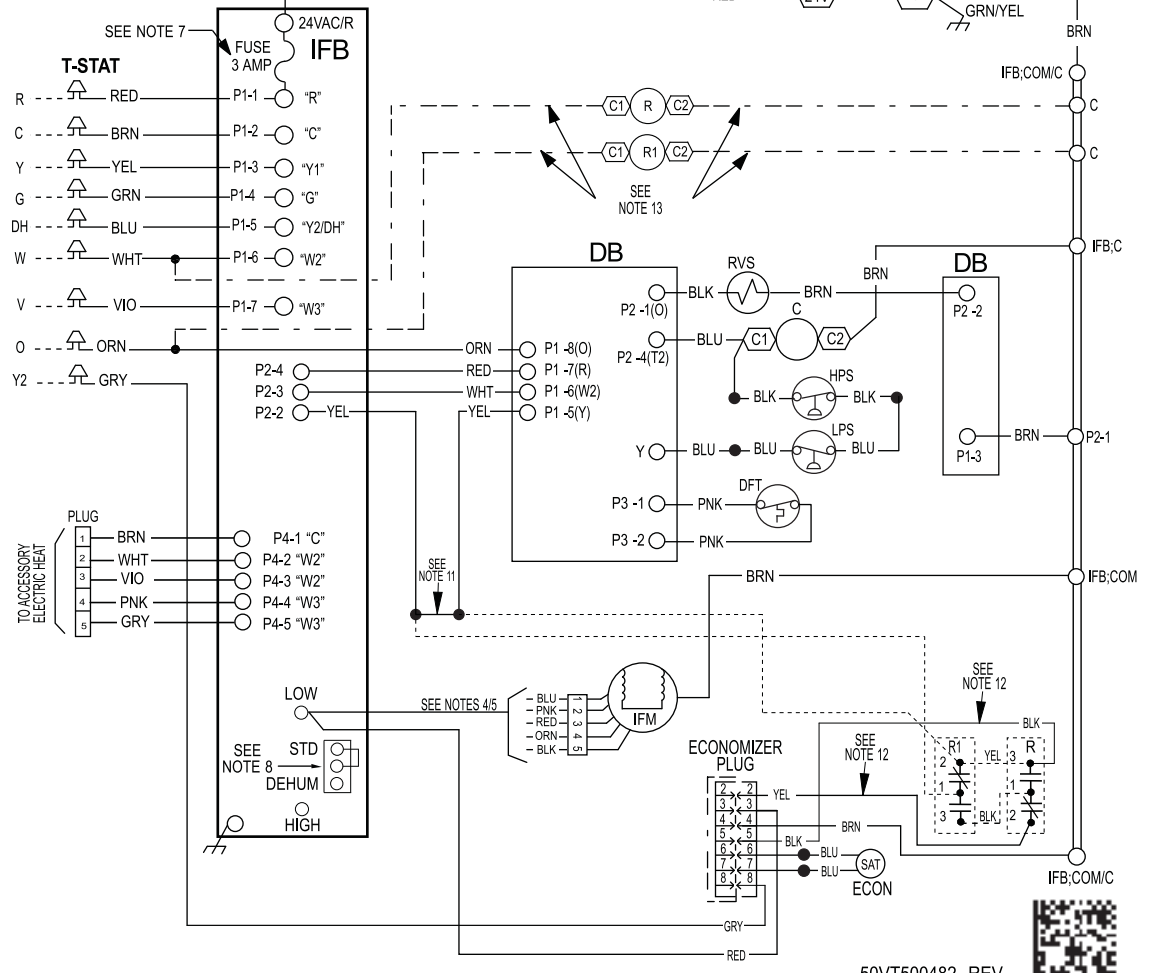
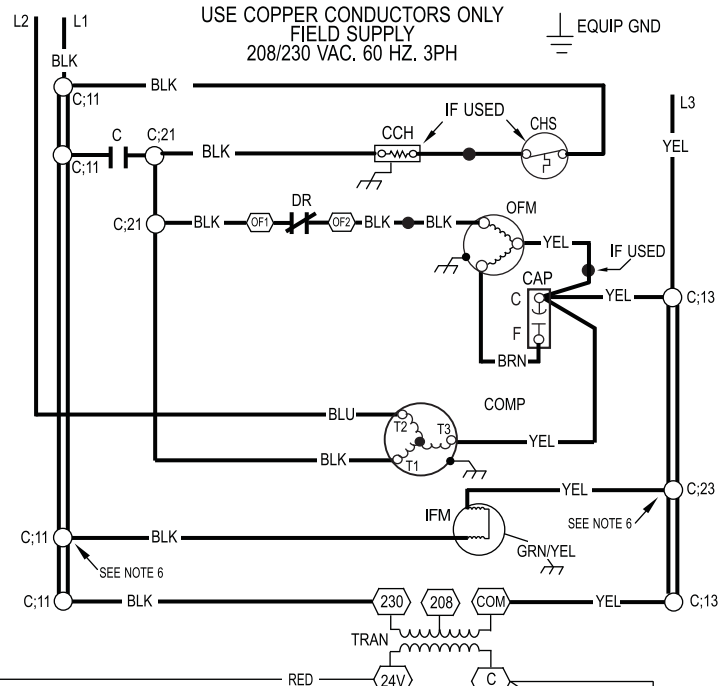
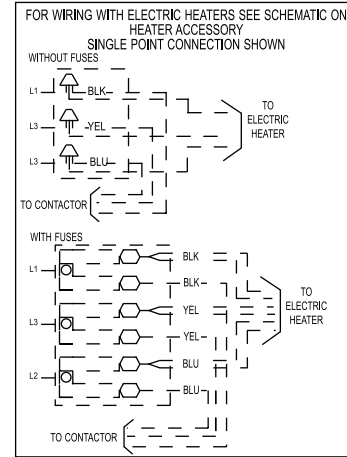

50VT500482 REV. -



TYPICAL CONNECTION WIRING SCHEMATIC – 460-3-60

CONNECTION WIRING DIAGRAM

DANGER: ELECTRICAL SHOCK HAZARD DISCONNECT POWER BEFORE SERVICING

SCHEMATIC 460-3-60

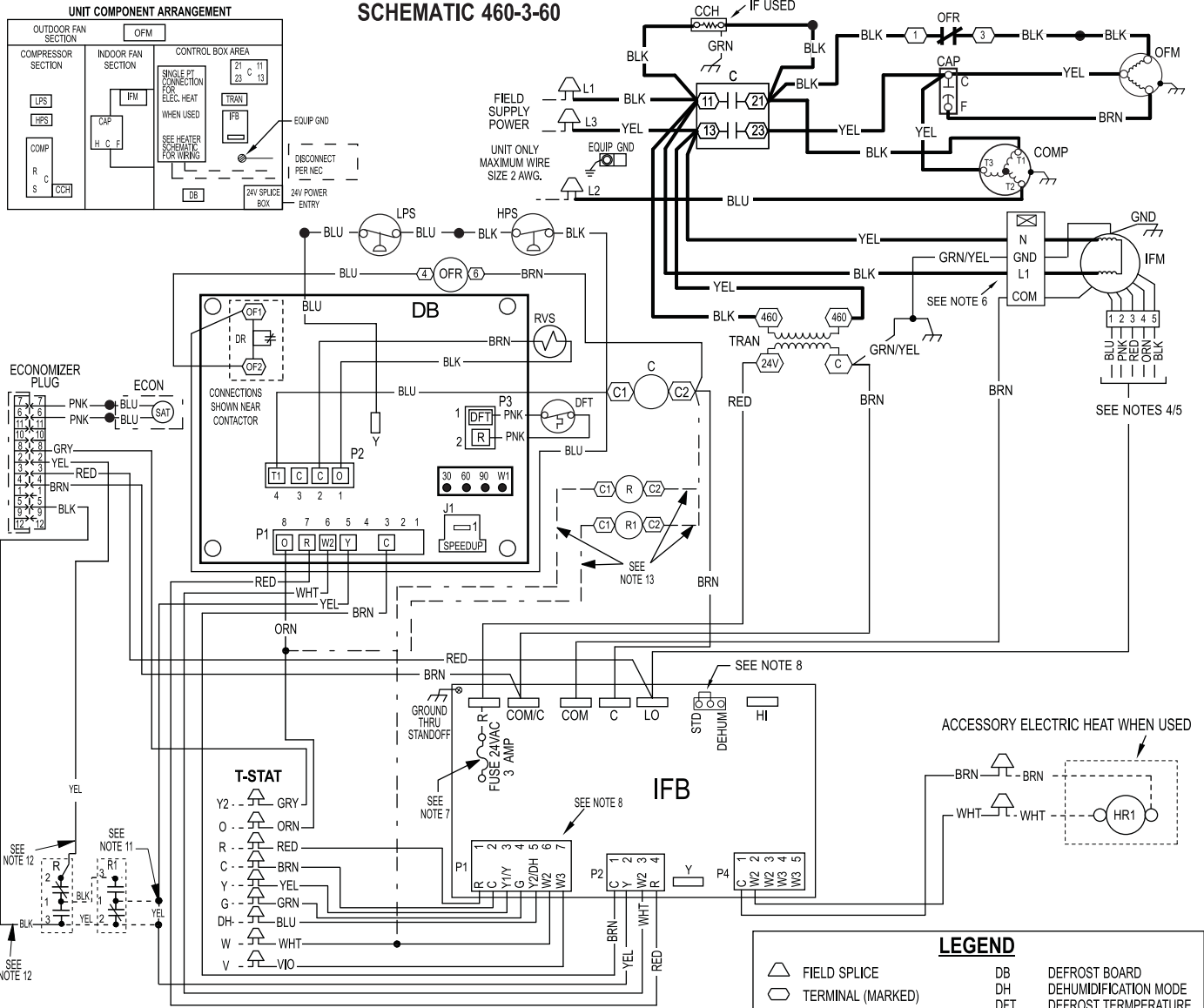

NOTES:

1. IF ANY OF THE ORIGINAL WIRES FURNISHED ARE REPLACED IT MUST BE REPLACED WITH THE SAME OR ITS EQUIVALENT.
2. SEE PRE SALE LITERATURE FOR THERMOSTATS.
3. USE 75 DEGREES C COPPER CONDUCTORS FOR FIELD INSTALLATION.
4. REFER TO INSTALLATION INSTRUCTIONS FOR CORRECT SPEED SELECTION FOR IFM.
5. RELOCATION OF SPEED TAPS MAY BE REQUIRED WHEN USING FIELD INSTALLED ELECTRIC HEATERS. CONSULT INSTALLATION INSTRUCTIONS TO DETERMINE CORRECT SPEED TAP SETTING.
6. "DO NOT DISCONNECT PLUG UNDER LOAD".
7. THIS FUSE IS MANUFACTURED BY LITTLE FUSE, P/N 287003.
8. DEHUM FEATURE CANNOT BE USED WHEN ECONOMIZER IS INSTALLED. UNIT FACTORY - SHIPPED IN STD MODE.
9. N.E.C. CLASS 2, 24V.
10. CCH NOT USED ON ALL UNITS.
11. REMOVE YELLOW SPLICE WHEN ECONOMIZER AND ECONOMIZER RELAYS ARE USED AND CONNECT TO RELAY R1 AS SHOWN.
12. WHEN ECONOMIZER AND ECONOMIZER RELAYS ARE USED CONNECT THE YELLOW AND BLACK WIRES TO RELAY "R" AS SHOWN. RELAY KIT REQUIRED WITH ECONOMIZER AND HEAT PUMP / DUAL FUEL UNITS.
13. WHEN ECONOMIZER AND ECONOMIZER RELAYS ARE USED, INSTALL WIRES AS SHOWN ONTO THE COILS OF RELAY R AND RELAY R1.

TYPICAL LADDER WIRING SCHEMATIC – 460–3–60

LADDER WIRING DIAGRAM

DANGER: ELECTRICAL SHOCK HAZARD DISCONNECT POWER BEFORE SERVICING

DEFROST TIMING SELECTION

FIELD SELECTABLE OPTIONS FOR TIME PERIOD BETWEEN DEFROST CYCLES (MINUTES)
FACTORY DEFROST SETTING IS 60 MIN.

SPEED UP JUMPERED TEST PINS (USE METAL OBJECT) FIELD SPEED-UP CYCLE

- DFT MUST BE CLOSED TO INITIATE DEFROST CYCLE. IF NECESSARY, REMOVE DFT CONNECTION BEFORE PLACING JUMPER ACROSS DFT PINS.
- AT THE SAME TIME DFT CLOSED, JUMPER "SPEED UP" PINS WITH SMALL SCREW DRIVER UNTIL DEFROST IS INITIATED. THEN REMOVE SCREW DRIVER.
- SHORTED "SPEED UP" PINS WILL SPEED UP TIMER BY A FACTOR OF 256.

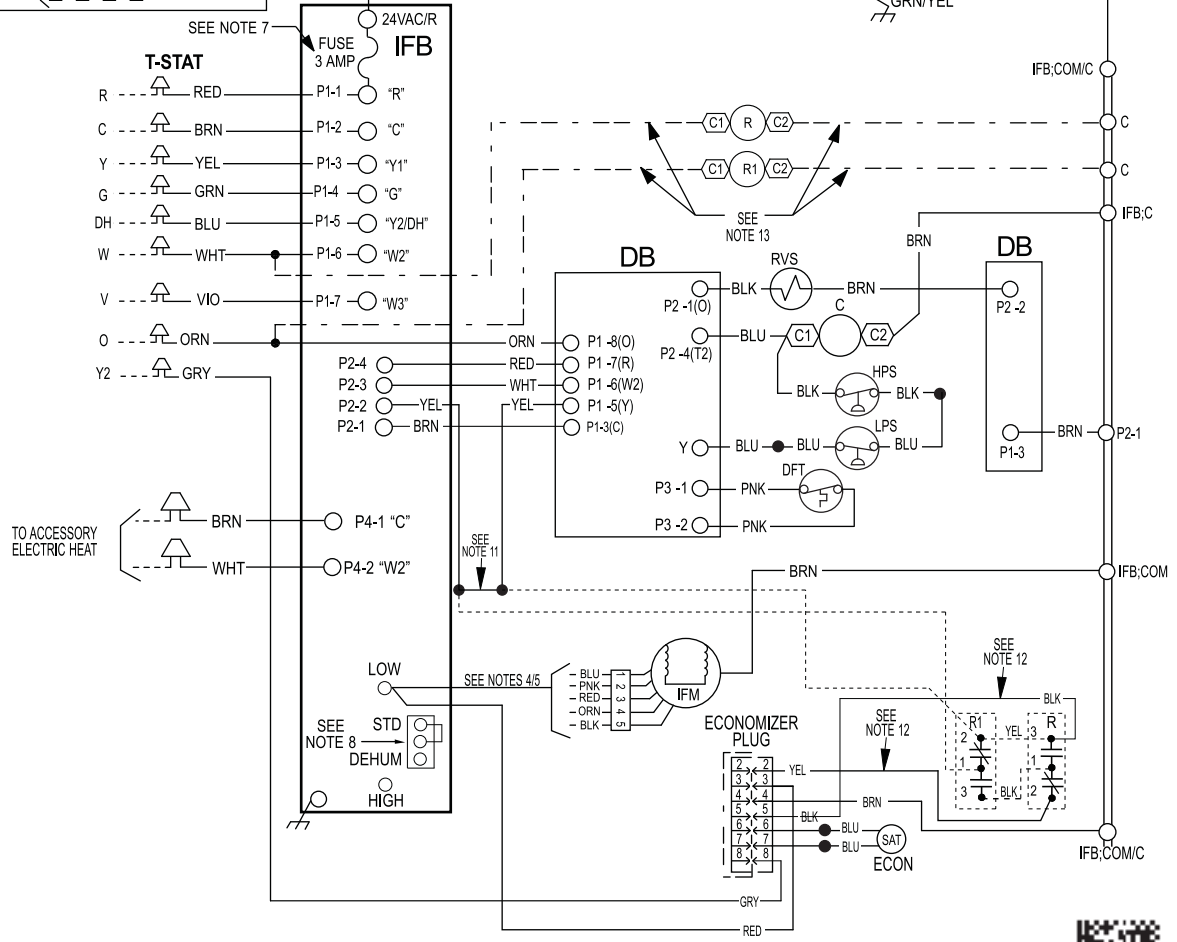
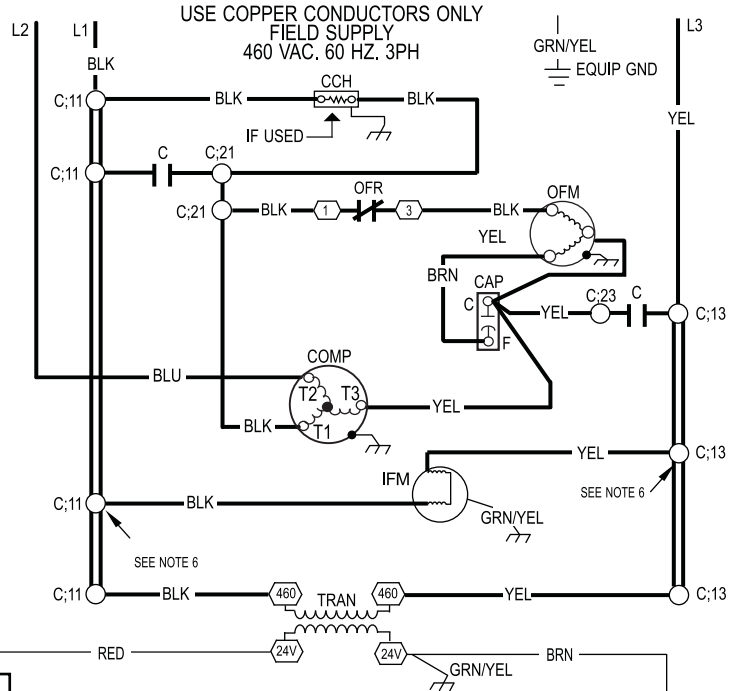
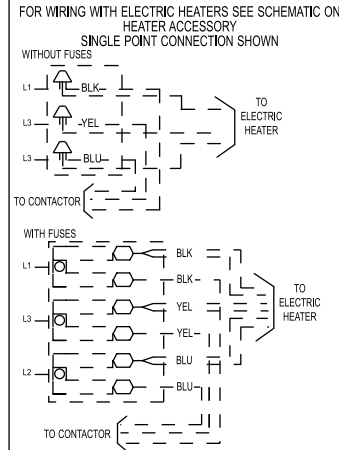

50VT500484 REV. -



A150523

CONTROLS

Operating sequence

When power is supplied to unit, the transformer (TRAN) is energized.

On units with crankcase heater, heater is also energized.

Cooling — With the thermostat in the cooling position, the thermostat makes circuit R–O. This energizes the reversing valve solenoid (RVS) and places the unit in standby condition for cooling.

As the space temperature rises, the thermostat closes circuit R–Y. A circuit is made to contactor (C), starting the compressor (COMP) and outdoor–fan motor (OFM). Circuit R–G is made at the same time and starts the indoor–fan motor (IFM).

When the thermostat is satisfied, contacts open, deenergizing C. The COMP and OFM stop, and the IFM stops after the preselected time delay.

Heating — On a call for heat, thermostat makes circuits R–Y and R–G.

A circuit is made to C, starting COMP and OFM. Circuit R–G also is completed, energizing IFR and starting IFM after the selected time delay.

Should room temperature continue to fall, circuit R–W is made through second–stage thermostat. If optional electric heat package is used, a relay is energized, bringing on first bank of supplemental electric heat. When thermostat is satisfied, contacts open, deenergizing contactor and relay; motors and heaters deenergize.

Defrost — Defrost board (DB) is a time and temperature control, which includes a field–selectable time period (dip switch 1 and 2 on the board) between checks for defrost (30, 60, 90, or 120 minutes). Electronic timer and defrost cycle start only when contactor is energized and defrost thermostat (DFT) is closed.

Defrost mode is identical to cooling mode, except outdoor fan motor stops and a bank of optional electric heat turns on to warm air supplying the conditioned space.

NOTE:

1. Compressor time delay occurs through the defrost control board.
2. Defrost control board has built in 5 minute compressor delay; once the compressor has started and then stopped, it cannot be restarted again until 5 minutes have elapsed.

GUIDE SPECIFICATIONS

Packaged Heat Pump System

HVAC Guide Specifications

Size Range: **2 to 5 Tons, Nominal Cooling**

Part 1—General

SYSTEM DESCRIPTION

Outdoor, packaged, air–to–air heat pump unit utilizing a hermetic scroll compressor for cooling duty and optional electric heating. Unit shall discharge supply air vertically or horizontally as shown on contract drawings. Outdoor fan/coil section shall have a draw–thru design with vertical discharge for minimum sound levels.

QUALITY ASSURANCE

- A. Unit shall be rated in accordance with AHRI Standards 210/240 and 270.
- B. Unit shall be designed in accordance with UL Standard 1995.
- C. Unit shall be manufactured in a facility registered to ISO 9001 manufacturing quality standard.

D. Unit shall be UL listed and c–UL certified as a total package for safety requirements.

E. Roof curb shall be designed to conform to NRCA Standards.

F. Insulation and adhesives shall meet NFPA 90A requirements for flame spread and smoke generation.

G. Cabinet insulation shall meet ASHRAE Standard 62P.

DELIVERY, STORAGE AND HANDLING

Unit shall be stored and handled per manufacturer's recommendations.

Part 2 — Products

EQUIPMENT

A. General:

Factory–assembled, single–piece, heat pump unit. Contained within the enclosure shall be all factory wiring, piping, controls, refrigerant charge (R–410A), and special features required prior to field start–up.

B. Unit Cabinet:

1. Unit cabinet shall be constructed of phosphated, zinc–coated, pre–painted steel capable of withstanding 500 hours of salt spray.
2. Normal service shall be through 3 removable cabinet panels.
3. The unit shall be constructed on a rust proof unit base that has an externally trapped, integrated sloped drain.
4. Indoor fan compartment top surface shall be insulated with a minimum 1/2–in. (13 mm) thick, flexible fiberglass insulation, coated on the air side and retained by adhesive and mechanical means. The indoor wall sections will be insulated with a minimum semi–rigid, foil–faced board capable of being wiped clean. Aluminum foil–faced fiberglass insulation shall be used in the entire indoor air cavity section.
5. Unit shall have a field–supplied condensate trap.
6. Metal Insulated Duct Covers for side discharge will be standard on all sizes.
7. Unit insulation conforms to ASHRAE 62P.

C. Fans:

1. The indoor fan shall be 5–speed, direct–drive, as shown on equipment drawings.
2. Fan wheel shall be made from steel and shall be double–inlet type with forward–curved blades with corrosion resistant finish. Fan wheel shall be dynamically balanced.
3. Outdoor fan shall be direct–drive, propeller–type with aluminum blades riveted to corrosion resistant steel spiders, be dynamically balanced, and discharge air vertically.

D. Compressor:

1. Fully hermetic compressors with factory–installed vibration isolation.
2. Scroll compressors shall be standard on all units.

E. Coils:

Indoor and outdoor coils shall have aluminum plate fins mechanically bonded to seamless copper tubes with all joints brazed. Tube sheet openings shall be belled to prevent tube wear.

F. Refrigerant Metering Device:

Refrigerant metering device shall be thermostatic expansion valve or fixed orifice for cooling, and fixed orifice for heating.

G. Filters:

Filter section shall consist of field–installed, throwaway, 1–in. (25 mm) – thick fiberglass filters of commercially available sizes.

H. Controls and Safeties:

1. Unit controls shall be complete with a self-contained, low-voltage control circuit.
2. Units shall incorporate an internal compressor protector that provides reset capability.

I. Operating Characteristics:

1. Unit shall be capable of starting and running at 125°F (51.7°C) ambient outdoor temperature.
2. Compressor with standard controls shall be capable of operation down to 40°F (4.4°C) ambient outdoor temperature in cooling mode.
3. Unit shall be provided with 90-second fan time delay after the thermostat is satisfied.

J. Electrical Requirements:

All unit power wiring shall enter the unit cabinet at a single location.

K. Motors:

1. Compressor motors shall be of the refrigerant-cooled type with line-break thermal and current overload protection.
2. All fan motors shall have permanently lubricated bearings, and inherent, automatic reset, thermal overload protection.
3. Condenser fan motor shall be totally enclosed.
4. Evaporator fan motor to be ECM Motor.

L. Special Features Available:

1. Compressor Start Kit (single phase units only):
Shall provide additional starting torque for single-phase compressors.
2. Thermostat:
To provide for two-stage heating and one-stage cooling in addition manual or automatic changeover and indoor fan control.
3. Crankcase Heater:
Shall provide anti-floodback protection for lowload cooling applications.
4. Economizer:
(Horizontal – Field installed accessory)
(Vertical – Field installed accessory)
 - a. Economizer controls capable of providing free cooling using outside air.
 - b. Equipped with low leakage dampers not to exceed 3% leakage, at 1.0 in. W.C. pressure differential.
 - c. Spring return motor shuts off outdoor damper on power failure.

5. Electric Heaters

- a. Electric heater shall be available as a field installed option.
- b. Heater elements shall be open wire type, adequately supported and insulated with ceramic bushings.
- c. Electric heater packages must provide single point power connection capability.

6. Filter Rack Kit:

Shall provide filter mounting for downflow applications. Offered as a field installed accessory.

7. Flat Roof Curb:

Curbs shall have seal strip and a wood nailer for flashing and shall be installed per manufacturer's instructions.

8. Low Ambient Package:

Shall consist of a solid-state control and outdoor coil temperature sensor for controlling outdoor-fan motor operation, which shall allow unit to operate down to 0°F (-17.7°C) outdoor ambient temperature.

9. Manual Outdoor Air Damper:

Package shall consist of damper, birdscreen, and rainhood which can be preset to admit outdoor air for year-round ventilation.

10. Square-To-Round Duct Transitions (24–48 size):

Shall have the ability to convert the supply and return openings from rectangular to round.

11. Dual Point Electric Heaters:

Allows you to power the electric heater and unit contactor separately by having two individual field power supply circuits connected respectively.

12. Cabinet Leakage

Cabinet air leakage less than 2.0% at 1.0 inch W.C. and cabinet air leakage less than 1.4% at 0.5 inch W.C., when tested in accordance with ASHRAE standard 193. Available as a factory installed option.

PHD4 ACCESSORIES		
Accessory Model Number	Description	Use With
CURBS		
CPRFCURB011A00	Roof Curb, 14" High	24 – 30
CPRFCURB013A00	Roof Curb, 14" High	36 – 60
Note: CPRFCURB011A00 can be used with 42–60 size units with some overhang.		
ADAPTER CURBS*		
CPADCURB001A00	Adapter curb for use with NPRFCURB006A00 & NPRFCURB007A00	24 – 30
CPADCURB002A00	Adapter curb for use with NPRFCURB008A00 & NPRFCURB009A00	36 – 60
* Can also be used when replacing other manufacturer's older generation units that contain a composite base without a metal base rail.		
CONCENTRIC ADAPTERS – (Use with curb only)		
NPCONADP001A00	For 18" round duct (use with curb CPRFCURB011A00)	Small Curb
NPCONADP002A00	For 18" round duct (use with curb CPRFCURB013A00)	Large Curb
ECONOMIZERS		
CPECOMZR007B00	Dedicated Vertical Economizer – Internal with solid state controller, gear driven, fully modulating damper, spring return actuator, up to 50% barometric relief, supply and dry bulb outdoor air sensors. Includes filter rack with 1" filters.	24, 30
CPECOMZR008A00		42, 48
CPECOMZR009A00		36, 60
CPECOMZR010A00	Dedicated Horizontal Economizer – Internal with solid state controller, fully modulating damper, spring return actuator, supply and dry bulb outdoor air sensor, and low ambient compressor lockout switch included. Includes filter rack with 1-inch filters.	24, 30
CPECOMZR011A00		42, 48
CPECOMZR012A00		36, 60
CPRLYKIT001A00	Economizer Relay for Heat Pumps	ALL
AXB078ENT	Outdoor Enthalpy Control	ALL
* Outdoor enthalpy available as field installed accessory; Filter rack and 1" filter, same as CPFILTRK kit		
DAMPERS		
CPMANDPR007A00	Manual Outside Air Damper (Includes filter rack and 1" filter, same as CPFILTRK kit)	24, 30
CPMANDPR008A00		42, 48
CPMANDPR009A00		36, 60
INTERNAL FILTER RACKS		
CPFILTRK007A00	Internal Filter Rack (includes 1-inch filters)	24, 30
CPFILTRK008A00		42, 48
CPFILTRK009A00		36, 60
CRANKCASE HEATERS		
CPCRKHTR008A00	240V Crankcase Heater	24 – 36
CPCRKHTR004A00		42 – 60
CPCRKHTR009A00	460V Crankcase Heater	24 – 36
CPCRKHTR005A00		42 – 60
LOW AMBIENT, ANTI-CYCLE TIMER, COMPRESSOR START ASSIST		
CPLOWAMB001A00	Low Ambient Control – enables cooling system to operate down to 0 Deg. F by cycling condenser fan on and off.	ALL
NRTIMEGD001A00	Five Minute Compressor Delay	ALL
CPHSTART002A00	PTC Compressor Start Assist Kit (All single phase)	ALL
HAIL GUARDS / COIL PROTECTION (Factory installed on PHD4 "TP" models)		
NAPA00901GR	3/8" spacing dense wire grilles 18"	24
NAPA01401GR	3/8" spacing dense wire grilles 22"	30
NAPA01001GR	3/8" spacing dense wire grilles 18"	36, 60
NAPA01301GR	3/8" spacing dense wire grilles 24"	42, 48
DUCT TRANSITIONS		
NPDUCFLG002A00	Square to Round (1 set of 2, use with horizontal duct flanges only)	24 – 48

PHD4 ACCESSORIES (CONT.)				
ELECTRIC HEATERS	Voltage / Nominal Capacity kW / Fuses			
PART NO.	NOMINAL CAPACITY (kW)	FUSED	STAGES	USED WITH
208/230V – 1 PHASE – 60 HZ				
CPHEATER052A0*	3.8 / 5.0	NO	1	24 – 36
CPHEATER064A0*	3.8 / 5.0	YES	1	ALL
CPHEATER069A0*	5.4 / 7.2	NO	1	24
CPHEATER070A0*	5.4 / 7.2	YES	1	ALL
CPHEATER050A0*	7.5 / 10.0	YES	1	ALL
CPHEATER066A0*	11.3 / 15.0	YES	2	30 – 60
CPHEATER054A0*	15.0 / 20.0	YES	2	42 – 60
208/230V – 3 PHASE – 60 HZ				
CPHEATER055A0*	3.8 / 5.0	NO	1	36 – 60
CPHEATER056A0*	7.5 / 10.0	NO	1	36 – 42
CPHEATER068A0*	7.5 / 10.0	YES	1	36 – 60
CPHEATER058A0*	11.3 / 15.0	YES	1	36 – 60
CPHEATER059A0*	15.0 / 20.0	YES	1	42 – 60
460V – 3 PHASE – 60 HZ				
CPHEATER061A0*	10.0	NO	1	36 – 60
CPHEATER062A0*	15.0	NO	1	36 – 60
CPHEATER063A0*	20.0	NO	1	42 – 60

* Denotes digit can be 0, 1, or 2

NOTE: If installing an accessory heater, the thermostat must have capability to energize "G" (fan) on a call for "W" (electric heat). TSTAT0406 and TSTAT0408 contain this feature.