

INSTALLATION MANUAL

**R-410A
ZQ SERIES**

3 - 5 Ton

60 Hertz



TABLE OF CONTENTS

General	2	Economizer Sequences	51
Installation	5	Dry Bulb Changeover	51
Preceding Installation	5	Single Enthalpy Changeover	51
Limitations	6	Dual Enthalpy Changeover	51
Location	6	Auto	51
Rigging And Handling	7	Free Cooling Operation	52
ZQ04-06 Unit Weights	8	Power Exhaust	52
Ductwork	12	Setpoints	52
Condensate Drain	13	Inputs	52
Compressors	14	Outputs	52
Filters	14	Operation	52
Power And Control Wiring	14	Gas Heating Operation	56
Typical Field Power and Control Wiring	16	Gas Heat Ignition Control Board Function	57
Typical Power Wiring	16	Start-Up (Cooling)	58
Optional Gas Heat	33	Start-Up (Gas Heat)	59
Options/Accessories	35	Checking Gas Heat Input	59
Blower Phasing	35	Troubleshooting	64
Airflow Performance	38	Control Board Navigation Components	68
Operation	51	Smart Equipment™ Firmware Version 3.3 Basic Unit Control Board Navigation Examples	69
Compressor Operation	51	Start-Up Sheet	71
IntelliSpeed Supply Fan Control	51		

LIST OF TABLES

1 ZQ04-06 Unit Limitations	6	16 ZQ04-06 Bottom Duct Application (Direct Drive)	42
2 ZQ04-06 Corner Weights	8	17 RPM Selection	42
3 ZQ04-06 Unit Accessory Weights	9	18 Indoor Blower Specifications	43
4 ZQ04-06 Unit Clearances	12	19 Motor Sheave Datum Diameters	43
5 Unit Models used with 1RC0456, 1RC0458 Roof Curb	12	20 Additional Static Resistance - ZQ04-06	44
6 Control Wire Sizes	15	21 Smart Equipment™ UCB Details	45
7 Electrical Data	17	22 Cable for FC Buses and SA Buses in Order of Preference	50
8 Physical Data	27	23 Smart Equipment™ Economizer Board Details	53
9 Gas Pipe Sizing - Capacity of Pipe	33	24 Gas Rate Cubic Feet Per Hour	60
10 Gas Heat Supply Air	33	25 Gas Heat Stages	61
11 Supply Air Limitations	35	26 Flash Codes for the Gas Heat Ignition Control Board	64
12 Altitude/Temperature Correction Factors	37	27 ZQ04 Charging Table	67
13 ZQ04-06 Side Duct Application (Belt Drive)	39	28 ZQ05 Charging Table	67
14 ZQ04-06 Side Duct Application (Direct Drive)	40	29 ZQ06 Charging Table	68
15 ZQ04-06 Bottom Duct Application (Belt Drive)	41		

LIST OF FIGURES

1 Unit Shipping Bracket	5	14 Typical Smart Equipment™ Control Wiring	16
2 Condenser Covering	5	15 Side Entry Gas Piping	33
3 Return Air Smoke Detector Field Location	5	16 Flue Exhaust Hood Shipping Location	34
4 Unit 4 Point Load Weight	8	17 Flue Exhaust Hood Installed	35
5 Unit 6 Point Load Weight	8	18 Belt Adjustment	36
6 Center of Gravity	8	19 Altitude/Temperature Correction Factors	37
7 ZQ04-05 Unit Dimensions	10	20 Unit Control Board	45
8 ZQ06 Unit Dimensions	11	21 SE-ECO1001-1 Economizer Controller	53
9 1RC0456, 1RC0458 Roof Curb Dimensions	12	22 Ignition Control Board	56
10 Side Duct Cover Panels	13	23 Typical Flame	62
11 Bottom Return Opening For Side Duct Conversion	13	24 3 Thru 5 Ton, 1/2" Single Stage Gas Valve	63
12 Bottom Supply Opening For Side Duct Conversion	13	25 3 Thru 5 Ton, 1/2" Two Stage Gas Valve	63
13 Condensate Drain	14		

General

ZQ units are single package air conditioners with optional gas heating designed for outdoor installation on a rooftop or slab and for non-residential use.

These units are completely assembled on rigid, permanently attached base rails. All piping, refrigerant charge, and electrical wiring is factory installed and tested. The units require electric power, gas supply (where applicable), and duct connections.

Safety Considerations

 This is a safety alert symbol. When you see this symbol on labels or in manuals, be alert to the potential for personal injury.

Understand and pay particular attention the signal words **DANGER**, **WARNING** or **CAUTION**.

DANGER indicates an **imminently** hazardous situation, which, if not avoided, **will result in death or serious injury**.

WARNING indicates a **potentially** hazardous situation, which, if not avoided, **could result in death or serious injury**.

CAUTION indicates a potentially hazardous situation, which, if not avoided **may result in minor or moderate injury**. It is also used to alert against unsafe practices and hazards involving only property damage.

WARNING

Improper installation may create a condition where the operation of the product could cause personal injury or property damage. Improper installation, adjustment, alteration, service or maintenance can cause injury or property damage. Refer to this manual for assistance or for additional information, consult a qualified contractor, installer or service agency.

CAUTION

This product must be installed in strict compliance with the installation instructions and any applicable local, state and national codes including, but not limited to building, electrical, and mechanical codes.

WARNING

Before performing service or maintenance operations on unit, turn off main power switch to unit. Electrical shock could cause personal injury. Improper installation, adjustment, alteration, service or maintenance can cause injury or property damage. Refer to this manual. For assistance or additional information consult a qualified installer, service agency or the gas supplier.

CAUTION

This system uses R-410A Refrigerant which operates at higher pressures than R-22. No other refrigerant may be used in this system. Gauge sets, hoses, refrigerant containers and recovery systems must be designed to handle R-410A. If you are unsure, consult the equipment manufacturer. Failure to use R-410A compatible servicing equipment may result in property damage or injury.

WARNING

If the information in this manual is not followed exactly, a fire or explosion may result causing property damage, personal injury or loss of life.

Do not store or use gasoline or other flammable vapors and liquids in the vicinity of this or any other appliance.

WHAT TO DO IF YOU SMELL GAS:

- a. Do not try to light any appliance.
- b. Do not touch any electrical switch; do not use any phone in your building.
- c. Immediately call your gas supplier from a neighbor's phone. Follow the gas supplier's instructions.
- d. If you cannot reach your gas supplier, call the fire department.

Installation and service must be performed by a qualified installer, service agency or the gas supplier.

WARNING

ELECTRICAL SHOCK, FIRE OR EXPLOSION HAZARD

Failure to follow safety warnings exactly could result in dangerous operation, serious injury, death or property damage.

Improper servicing could result in dangerous operation, serious injury, death or property damage.

- Before servicing, disconnect all electrical power to furnace.
- When servicing controls, label all wires prior to disconnecting. Reconnect wires correctly.
- Verify proper operation after servicing.

Due to system pressure, moving parts, and electrical components, installation and servicing of air conditioning equipment can be hazardous. Only qualified, trained service personnel should install, repair, or service this equipment. Untrained personnel can perform basic maintenance functions of cleaning coils and filters and replacing filters.

Observe all precautions in the literature, labels, and tags accompanying the equipment whenever working on air

conditioning equipment. The installation must conform with local building codes or, in the absence of local codes, with the National Fuel Gas Code, ANSI Z223.1/NFPA 54, and/or the National Gas and Propane Installation Code, CSA B149.1.

Wear safety glasses and work gloves. Use quenching cloth and have a fire extinguisher available during brazing operations.

Inspection

As soon as a unit is received, it should be inspected for possible damage during transit. If damage is evident, the extent of the damage should be noted on the carrier's freight bill. A separate request for inspection by the carrier's agent should be made in writing.

CAUTION

This product must be installed in strict compliance with the enclosed installation instructions and any applicable local, state and national codes including, but not limited to, building, electrical, and mechanical codes.

The furnace and its individual shut-off valve must be disconnected from the gas supply piping system during any pressure testing at pressures in excess of 1/2 PSIG.

Pressures greater than 1/2 PSIG will cause gas valve damage resulting in a hazardous condition. If it is subjected to a pressure greater than 1/2 PSIG, the gas valve must be replaced.

The furnace must be isolated from the gas supply piping system by closing its individual manual shut-off valve during any pressure testing of the gas supply piping system at test pressures equal to or less than 1/2 PSIG

Reference

Additional information is available in the following reference forms:

- Technical Guide - ZX/ZQ/ZY04-14 1068152
- General Installation - ZQ04-06 5246355
- Economizer Accessory -
Vertical Flow Dry Bulb Economizer Field Installed
Horizontal Flow Dry Bulb Economizer Field Installed

- Power Exhaust -
Vertical Flow Dry Bulb Economizer Field Installed
Horizontal Flow Dry Bulb Economizer Field Installed

Renewal Parts

Contact your local UPG parts distribution center for authorized replacement parts.

Approvals

Design certified by CSA as follows:

1. For use as a cooling only unit, cooling unit with a forced air furnace.
2. For outdoor installation only.
3. For installation on combustible material and may be installed directly on combustible flooring or, in the U.S., on wood flooring or Class A, Class B or Class C roof covering materials.
4. For use with natural gas.

CAUTION

This product must be installed in strict compliance with the enclosed installation instructions and any applicable local, state, and national codes including, but not limited to, building, electrical, and mechanical codes.

WARNING

Improper installation may create a condition where the operation of the product could cause personal injury or property damage.

CAUTION

This system uses R-410A Refrigerant which operates at higher pressures than R-22. No other refrigerant may be used in this system.

Nomenclature

3-5 Ton Model Number Nomenclature

ZQ G 04 D 2 A 1 A A 1 1 1 1 A 2

Product Category
ZQ = Pkg AC R-410A 14 SEER Efficiency

Heat Type (3)
E = No Heat, Electric Heat Field Installed
G = Gas Heat

Nominal Cooling Capacity
04 = 3 Ton
05 = 4 Ton
06 = 5 Ton

Heat Size
A = No Heat (Cooling Only)
Gas Heat
D = Low Heat
E = Medium Heat
F = High Heat
L = Low Heat (Low NOx)
M = Medium Heat (Low NOx)
N = High Heat (Low NOx)
R = Low Heat (Stainless Steel)
S = Medium Heat (Stainless Steel)
T = High Heat (Stainless Steel)

Voltage
1 = 208/230-1-60 (3-5 Ton Only)
2 = 208/230-3-60
4 = 460-3-60
5 = 575-3-60

Airflow
A = Standard Static
B = Medium Static
C = High Static

Options
1 = None

Note: Not all options may be available. Contact local distributor.

Coil Options
A = Standard Indoor & Outdoor Coils
B = Standard Indoor Coil & ElectroFin Outdoor Coil
C = E-Coat Indoor Coil & Standard Outdoor Coil
D = E-Coat Indoor & Outdoor Coils

Product Generation
2 = Second Generation

Special Options
A = None

Cabinet Options
1 = None
2 = Louvered Panels Installed
3 = Hinged Cabinet Doors
4 = Hinged Cabinet Doors & Louvered Panels

Electrical Options
1 = None
2 = Non-fused Disconnect¹

¹. Verify on the unit nameplate that the disconnect is properly sized for the application. Units with field installed electric heat may exceed the factory installed disconnect amperage rating.

Convenience Outlet
1 = None
2 = Non-powered
3 = Powered

Economizer / Damper
A = None
B = Dry Bulb Economizer
C = Enthalpy Economizer

Sensor Options
1 = None (Units come standard with factory installed supply air, return air, and outdoor air temperature sensors)
2 = RA¹ Smoke Detector
3 = SA Smoke Detector
4 = RA¹ & SA Smoke Detector

¹. Return Air Smoke Detector Sensor Must Be Relocated in the Field. (See Unit Installation Manual.)

Controls
A = Smart Equipment™
B = Smart Equipment™ + BAS
C = Fault Detection and Diagnostics (FDD)
J = Verasys Single Zone
K = Verasys Change Over Bypass
M = Verasys Single Zone W/FDD
N = Verasys Change Over Bypass W/FDD

Installation

Installation Safety Information

Read these instructions before continuing this appliance installation. This is an outdoor combination heating and cooling unit. The installer must assure that these instructions are made available to the consumer and with instructions to retain them for future reference.

1. Refer to the unit rating plate for the approved type of gas for this product.
2. Install this unit only in a location and position as specified on Page 6 of these instructions.
3. Never test for gas leaks with an open flame. Use commercially available soap solution made specifically for the detection of leaks when checking all connections, as specified on Pages 5, 34, 34 and 59 of these instructions.
4. Always install furnace to operate within the furnace's intended temperature-rise range with the duct system and within the allowable external static pressure range, as specified on the unit name/rating plate, specified in Table 8 of these instructions.
5. This equipment is not to be used for temporary heating of buildings or structures under construction.

WARNING

FIRE OR EXPLOSION HAZARD

Failure to follow the safety warning exactly could result in serious injury, death or property damage.

Never test for gas leaks with an open flame. Use a commercially available soap solution made specifically for the detection of leaks to check all connections. A fire or explosion may result causing property damage, personal injury or loss of life.

Preceding Installation

1. Remove the two screws holding the brackets in the side fork-lift slots.



Figure 1: Unit Shipping Bracket

2. Turn each bracket toward the ground and the protective plywood covering will drop to the ground.
3. Remove the condenser coil external protective covering prior to operation.



Figure 2: Condenser Covering

4. If a factory option convenience outlet is installed, the weatherproof outlet cover must be field installed. The cover shall be located behind the filter access panel. To install the cover, remove the shipping label covering the convenience outlet, follow the instructions on the back of the weatherproof cover box, and attach the cover to the unit using the (4) screws provided.

CAUTION

208/230-3-60 and units with factory installed Powered Convenience Outlet Option are wired for 230v power supply. Change tap on transformer for 208-3-60 operation. See unit wiring diagram.

5. If a factory option return air smoke detector is installed, the return air sensor must be moved from a factory shipped (upside down) position to the (right side up) working position and the flex conduit sampler tube connected.

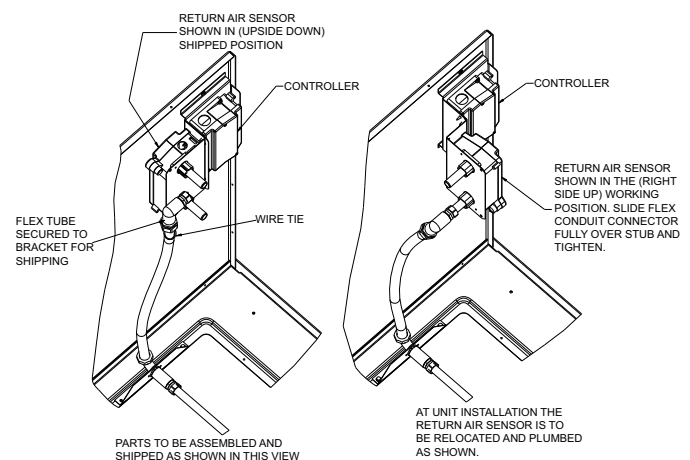

Figure 3: Return Air Smoke Detector Field Location

Limitations

These units must be installed in accordance with the following:

In U.S.A.:

1. National Electrical Code, ANSI/NFPA No. 70 - Latest Edition
2. National Fuel Gas Code, ANSI Z223.1 - Latest Edition
3. Gas-Fired Central Furnace Standard, ANSI Z21.47a. - Latest Edition
4. Local building codes, and
5. Local gas utility requirements

In Canada:

1. Canadian Electrical Code, CSA C22.1
2. Installation Codes, CSA - B149.1.

3. Local plumbing and waste water codes, and
4. Other applicable local codes.

Refer to unit application data found in this document.

After installation, gas fired units must be adjusted to obtain a temperature rise within the range specified on the unit rating plate.

If components are to be added to a unit to meet local codes, they are to be installed at the dealer's and/or customer's expense.

Size of unit for proposed installation should be based on heat loss/heat gain calculation made according to the methods of Air Conditioning Contractors of America (ACCA).

This furnace is not to be used for temporary heating of buildings or structures under construction.

Table 1: ZQ04-06 Unit Limitations

Model	Size (Tons)	Unit Voltage	Unit Limitations		
			Applied Voltage		Outdoor DB Temp
			Min	Max	Max (°F)
ZQ	04 (3)	208/230-1-60	187	252	125
		208/230-3-60	187	252	125
		460-3-60	432	504	125
		575-3-60	540	630	125
ZQ	05 (4)	208/230-1-60	187	252	125
		208/230-3-60	187	252	125
		460-3-60	432	504	125
		575-3-60	540	630	125
ZQ	06 (5)	208/230-1-60	187	252	125
		208/230-3-60	187	252	125
		460-3-60	432	504	125
		575-3-60	540	630	125

Location

Use the following guidelines to select a suitable location for these units:

1. Unit is designed for *outdoor installation only*.
2. Condenser coils must have an unlimited supply of air. Where a choice of location is possible, position the unit on either north or east side of building.
3. Suitable for mounting on roof curb.
4. For ground level installation, use a level concrete slab with a minimum thickness of 4 inches. The length and width should be at least 6 inches greater than the unit base rails. Do not tie slab to the building foundation.
5. Roof structures must be able to support the weight of the unit and its options/accessories. Unit must be installed on a solid, level roof curb or appropriate angle iron frame.
6. Maintain level tolerance to 1/2" across the entire width and length of unit.

WARNING

Excessive exposure of this furnace to contaminated combustion air will result in safety and performance related problems. Typical contaminants include: permanent wave solution, chlorinated waxes and cleaners, chlorine based swimming pool chemicals, water softening chemicals, de-icing salts or chemicals, carbon tetrachloride, Halogen type refrigerants, cleaning solvents (e.g. perchloroethylene), printing inks, paint removers, varnishes, hydrochloric acid, cements and glues, anti-static fabric softeners for clothes dryers, masonry acid washing materials.

Clearances

All units require particular clearances for proper operation and service. Installer must make provisions for adequate combustion and ventilation air in accordance with section 5.3 of Air for Combustion and Ventilation of the National Fuel Gas Code, ANSI Z223.1 – Latest Edition (in U.S.A.), or Sections 7.2, 7.3, or 7.4 of Gas Installation Codes, CSA-B149.1 (in Canada) - Latest Edition, and/or applicable provisions of the local building

codes. Refer to Table 4 for clearances required for combustible construction, servicing, and proper unit operation.

WARNING

Do not permit overhanging structures or shrubs to obstruct condenser air discharge outlet, combustion air inlet or vent outlets.

Rigging And Handling

Exercise care when moving the unit. Do not remove any packaging until the unit is near the place of installation. Rig the unit by attaching chain or cable slings to the lifting holes provided in the base rails. Spreader bars, whose length exceeds the largest dimension across the unit, **MUST** be used across the top of the unit.

CAUTION

If a unit is to be installed on a roof curb other than a UPG roof curb, gasketing must be applied to all surfaces that come in contact with the unit underside.

CAUTION

Before lifting, make sure the unit weight is distributed equally on the rigging cables so it will lift evenly.

Units may be moved or lifted with a forklift. Slotted openings in the base rails are provided for this purpose.

LENGTH OF FORKS MUST BE A MINIMUM OF 60 INCHES.

CAUTION

All panels must be secured in place when the unit is lifted.

The condenser coils should be protected from rigging cable damage with plywood or other suitable material.

ZQ04-06 Unit Weights

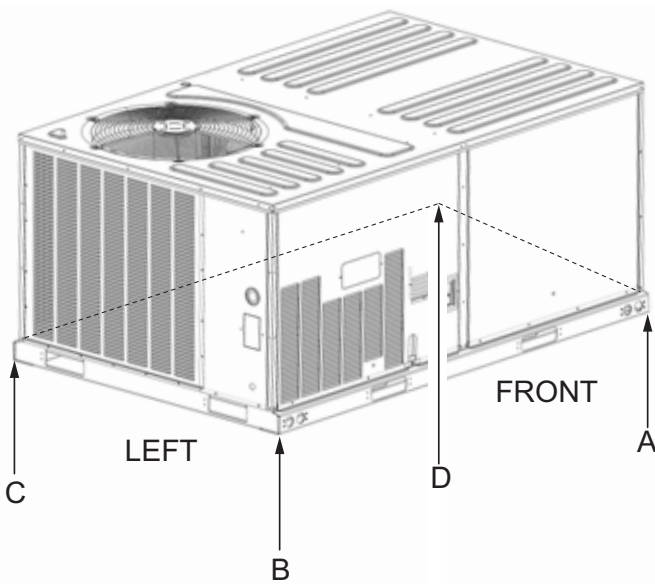

Figure 4: Unit 4 Point Load Weight

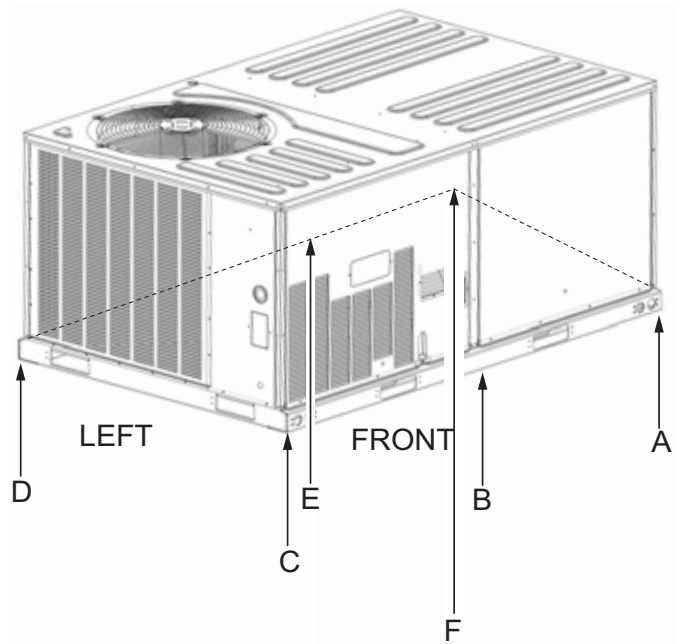

Figure 5: Unit 6 Point Load Weight

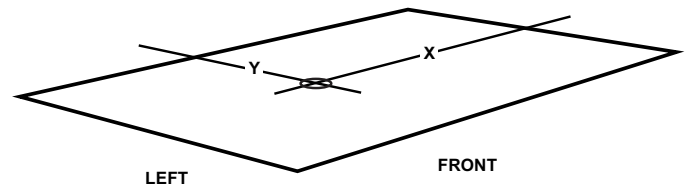

Figure 6: Center of Gravity

Table 2: ZQ04-06 Corner Weights

Model	Size (Tons)	Weight (lbs.)		Center of Gravity		4 Point Load Location (lbs.)				6 Point Load Location (lbs.)					
		Shipping	Operating	X	Y	A	B	C	D	A	B	C	D	E	F
ZQE	04 (3)	479	450	36	26	121	117	104	108	81	79	78	69	71	72
ZQE	05 (4)	516	487	36	26	131	124	113	119	88	85	82	75	77	80
ZQE	06 (5)	595	566	38	25	142	146	141	137	94	96	98	94	93	91
ZQG	04 (3)	527	498	36	27	141	132	109	116	95	91	87	72	75	79
ZQG	05 (4)	567	538	35	26	147	135	123	134	99	94	89	81	85	90
ZQG	06 (5)	644	615	36	26	168	157	140	150	113	108	103	93	97	101

Table 3: ZQ04-06 Unit Accessory Weights

Unit Accessory	Weights (lbs.)
Vertical Flow Dry Bulb Economizer Small Footprint	55
Horizontal Flow Dry Bulb Economizer Small Footprint Short	74
Horizontal Flow Dry Bulb Economizer Small Footprint Tall	76
Power Exhaust Vert Flow Small Footprint	55
Power Exhaust Horiz Flow Small Footprint	40
Hail Guard Kit Small Short Factory Installed	18
Hail Guard Kit Small Tall Factory Installed	23
Flue Extension Kit (1FE0414)	15
Flue Extension Kit (1FE0415)	17
Curb Rigid 14" Small Footprint	94
Curb Rigid 24" Small Footprint	148

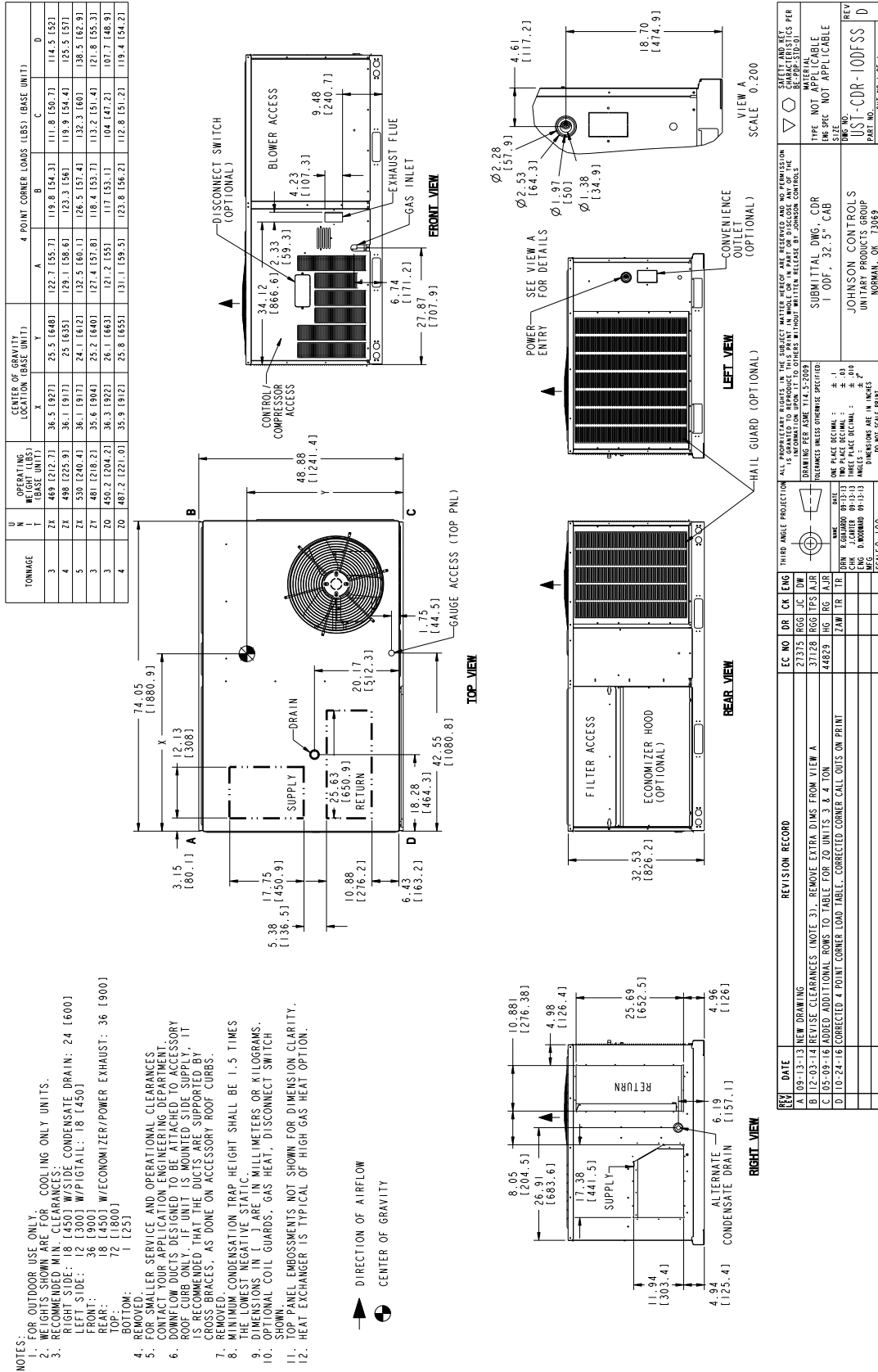
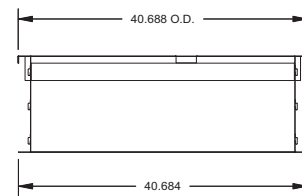
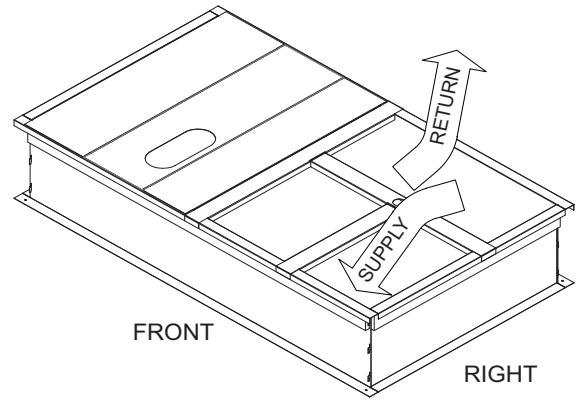
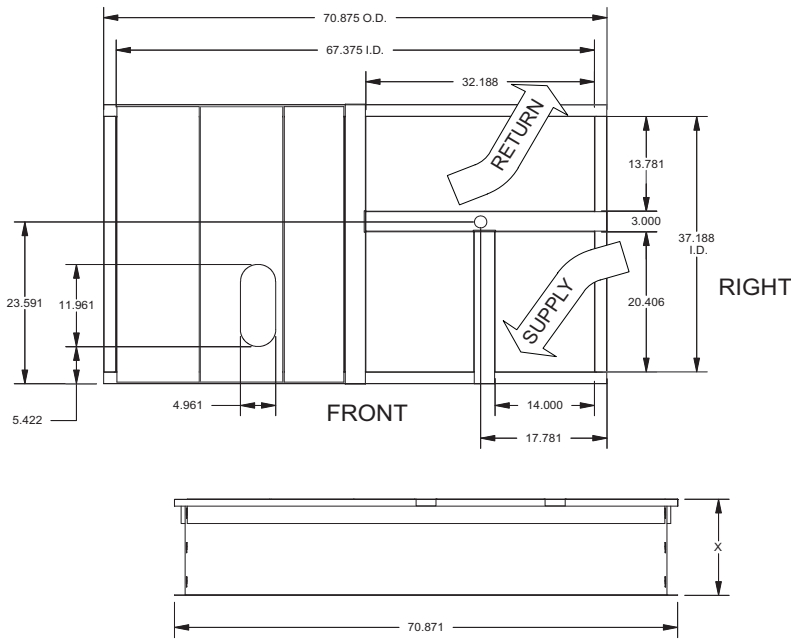

Figure 7: ZQ04-05 Unit Dimensions

Table 4: ZQ04-06 Unit Clearances

Direction	Distance (in.)	Direction	Distance (in.)
Top ¹	72	Right	18
Front	36	Left	12
Rear	18 ² /36 ³	Bottom ⁴	1

1. Units must be installed outdoors. Over hanging structure or shrubs should not obscure condenser air discharge outlet.
2. Units without economizer or power exhaust.
3. Units equipped with an Economizer or Power Exhaust. Flue products must not be discharged within 10 Feet of the rear of the unit.
4. Units may be installed on combustible floors made from wood or class A, B or C roof covering materials.



1RC0456 X= 14" Height
 1RC0458 X= 24" Height

Notes:

1. Sides, ends and cross support are 18-G90. Deck pans, R/A & S/A supports are 20-G90.
2. Full perimeter wood nailer.
3. Insulated deck pans.

Figure 9: 1RC0456, 1RC0458 Roof Curb Dimensions

Table 5: Unit Models used with 1RC0456, 1RC0458 Roof Curb

ZQ04
ZQ05
ZQ06

NOTE: If utilities are required thru the base of the unit or thru the roof curb the following field installed accessories can be purchased thru your dealer or contractor:

- 1TB0401 - Thru the base electrical and thru the curb gas
- 1TB0403 - Thru the base electrical and gas

Ductwork

Ductwork should be designed and sized according to the methods in Manual D of the Air Conditioning Contractors of America (ACCA) or as recommended by any other recognized authority such as ASHRAE or SMACNA.

A closed return duct system should be used. This will not preclude use of economizers or outdoor fresh air intake. The supply and return air duct connections at the unit should be made with flexible joints to minimize noise.

The supply and return air duct systems should be designed for the CFM and static pressure requirements of the job. They should NOT be sized to match the dimensions of the duct connections on the unit.

Refer to Figures 7 and 8 for bottom and side air duct openings.

Duct Covers

Units are shipped with the side duct openings covered and a covering over the bottom of the unit. For side duct application, remove the side duct covers and install over the bottom duct openings. The panels removed from the side duct connections are designed to be reused by securing each panel to its respective bottom duct opening. But keep in mind that the supply and return panels are installed with the painted surface DOWN, facing the bottom duct opening. The gasket must be removed from the insulation side of the duct cover so it is not directly exposed to the heating elements. The panels are secured by sliding them into slots in the back of the duct openings and screwing them to the base of the unit with screws (Use screws removed from original panel location.). Seals around duct openings must be tight.

CAUTION

When fastening ductwork to side duct flanges on unit, insert screws through duct flanges only. DO NOT insert screws through casing. Outdoor ductwork must be insulated and water-proofed.

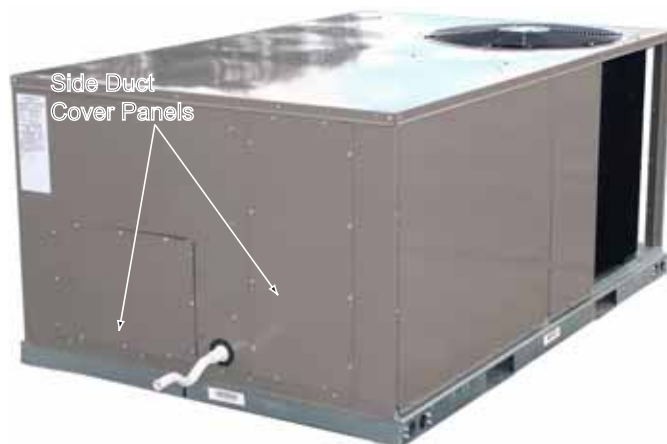

Figure 10: Side Duct Cover Panels

NOTE: Shown with duct connection cover panel as shipped.



Figure 11: Bottom Return Opening For Side Duct Conversion

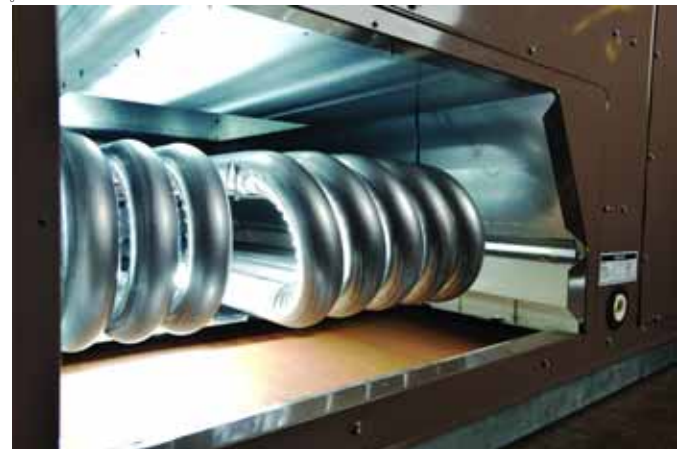

Figure 12: Bottom Supply Opening For Side Duct Conversion

Condensate Drain

A side condensate drain is provided to facilitate condensate piping. A condensate drain connection is available through the base pan for piping inside the roof curb. Trap the connection per Figure 13. The trap and drain lines should be protected from freezing.

Plumbing must conform to local codes. Use a sealing compound on male pipe threads. Install condensate drain line from the 3/4 inch NPT female connection on the unit to an open drain.

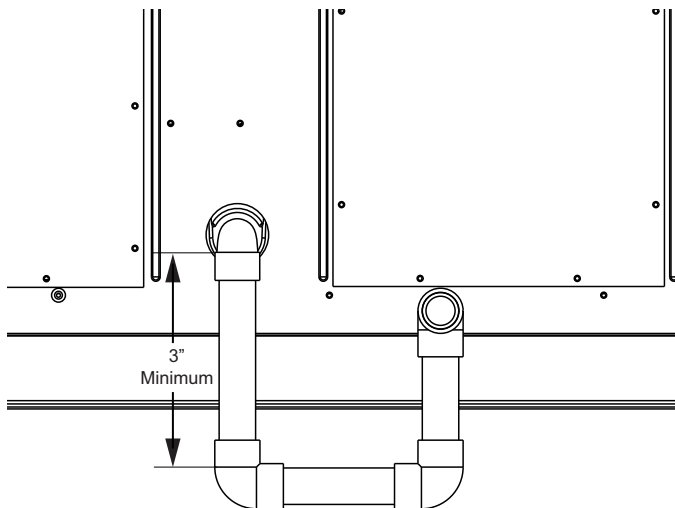

Figure 13: Condensate Drain

Compressors

The compressor used in this product is specifically designed to operate with R-410A Refrigerant and cannot be interchanged.

CAUTION

This system uses R-410A Refrigerant which operates at higher pressures than R-22. No other refrigerant may be used in this system.

The compressor also uses a refrigerant oil that is extremely hygroscopic, meaning it absorbs water readily. They can absorb 15 times as much water as other oils designed for HCFC and CFC refrigerants. Take all necessary precautions to avoid exposure of the oil to the atmosphere.

CAUTION

Do not leave the system open to the atmosphere. Unit damage could occur due to moisture being absorbed by the **refrigerant** in the system. This type of oil is highly susceptible to moisture absorption.

R-410A compressor lubricants are known to cause long term damage to some synthetic roofing materials.

CAUTION

Exposure, even if immediately cleaned up, may cause embrittlement (leading to cracking) to occur in one year or more. When performing any service that may risk exposure of compressor oil to the roof, take precautions to protect roofing.

Procedures which risk oil leakage include, but are not limited to, compressor replacement, repairing refrigerant leaks, replacing refrigerant components such as filter drier, pressure switch, metering device or coil.

Units are shipped with compressor mountings which are factory-adjusted and ready for operation.

CAUTION

Do not loosen compressor mounting bolts.

Filters

Two-inch filters are supplied with each unit. Four-inch filters may be used with no modification to the filter racks. Filters must always be installed ahead of evaporator coil and must be kept clean or replaced with same size and type. Dirty filters reduce the capacity of the unit and result in frosted coils or safety shutdown. Refer to physical data tables, for the number and size of filters needed for the unit. The unit should not be operated without filters properly installed.

Power And Control Wiring

Field wiring to the unit, fuses, and disconnects must conform to provisions of National Electrical Code (NEC), ANSI/NFPA No. 70 – Latest Edition (in U.S.A.), current Canadian Electrical Code C221, and/or local ordinances. The unit must be electrically grounded in accordance with NEC and CEC as specified above and/or local codes.

Voltage tolerances which must be maintained at the compressor terminals during starting and running conditions are indicated on the unit Rating Plate and Table 1.

CAUTION

208/230-3-60 and 208/230-1-60 units control transformers are factory wired for 230v. Change tap on transformer for 208v operation. See unit wiring diagram.

The internal wiring harnesses furnished with this unit are an integral part of the design certified unit. Field alteration to comply with electrical codes should not be required. If any of the wire supplied with the unit must be replaced, replacement wire must be of the type shown on the wiring diagram and the same minimum gauge as the replaced wire.

A disconnect must be utilized for these units. Factory installed disconnects are available. If installing a disconnect (field supplied), refer to Figures 7 and 8 for the recommended mounting location.

▲ CAUTION

Avoid damage to internal components if drilling holes for disconnect mounting.

NOTE: Since not all local codes allow the mounting of a disconnect on the unit, please confirm compliance with local code before mounting a disconnect on the unit.

Electrical line must be sized properly to carry the load. USE COPPER CONDUCTORS ONLY. Each unit must be wired with a separate branch circuit fed directly from the meter panel and properly fused.

▲ CAUTION

When connecting electrical power and control wiring to the unit, water-proof connectors must be used so that water or moisture cannot be drawn into the unit during normal operation. The above water-proofing conditions will also apply when installing a field supplied disconnect switch.

▲ CAUTION

When installing equipment in a facility with a 3 phase high-leg delta power supply, care must be taken to ensure that the high-leg conductor is not attached to either of the two legs of the (single phase, direct drive) X13 or ECM motors. Failure to do so can result in the motor acting erratically or not running at all.

Check for the high leg conductor by checking voltage of each phase to ground.

Example: A or L1 phase to ground, voltage reading is 120V. B or L2 phase to ground, voltage reading is 195 to 208V. C or L3 phase to ground, voltage reading is 120V. Therefore B or L2 phase is the high Leg. The high should always be wired to the center or B or L2 tap.

Note: Check all three phase motors and compressors for proper rotation after making a change. If it is necessary to change 3 phase motor rotation, swap A or L1 and C or L3 only.

Thermostat Wiring

A two stage thermostat must be used and should be located on an inside wall approximately 56 inch above the floor where it will not be subject to drafts, sun exposure or heat from electrical fixtures or appliances. Follow the manufacturer's instructions enclosed with thermostat for general installation procedure. Color-coded, insulated wires should be used to connect the thermostat to the unit. Refer to Table 6 for control wire sizing and maximum length.

Table 6: Control Wire Sizes

Wire Size	Maximum Length ¹
18 AWG	150 Feet

1. From the unit to the thermostat and back to the unit.

Typical Field Power and Control Wiring

Typical Power Wiring

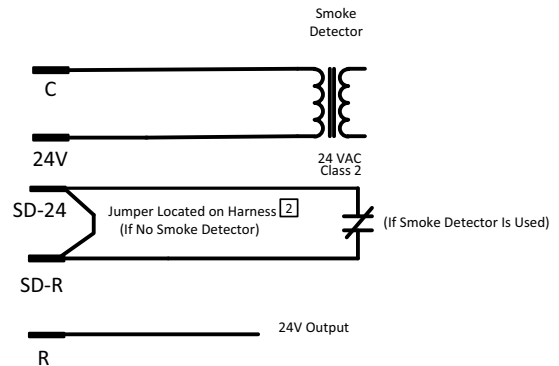
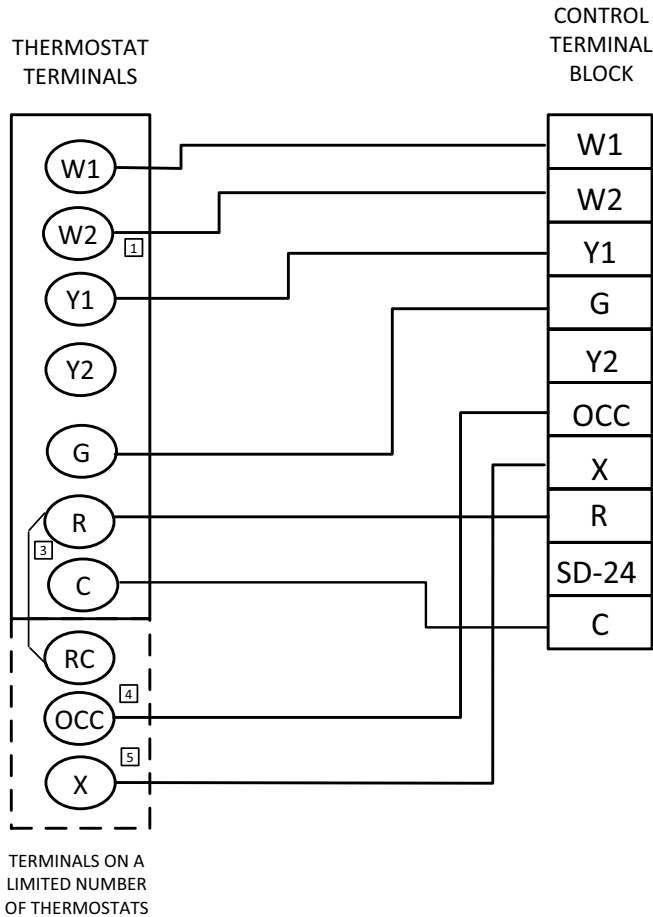
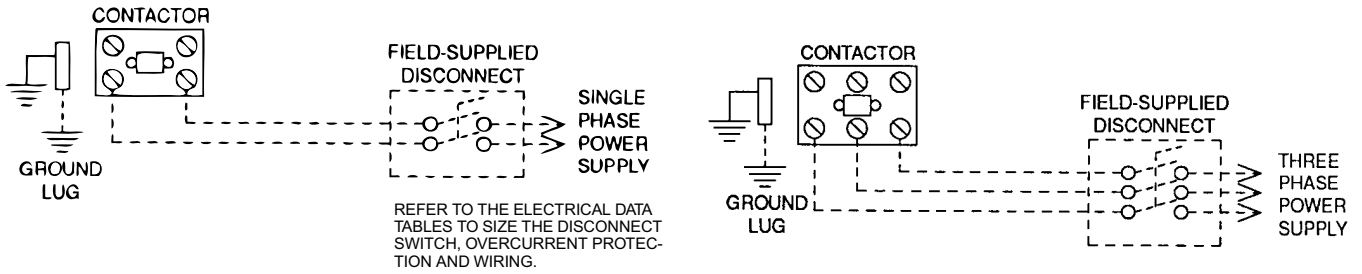

- 1 Second stage heating not required on single stage heating units.
- 2 Jumper is required if there is no Smoke Detector circuit.
- 3 Jumper is required for any combination of R, RC, or RH.
- 4 OCC is an output from the thermostat to indicate the Occupied condition.
- 5 X is an input to the thermostat to display Error Status conditions.

Figure 14: Typical Smart Equipment™ Control Wiring

Table 7: Electrical Data

ZQ04-06 Standard Static Indoor Blower - Without Powered Convenience Outlet

Size (Tons)	Nominal Unit Voltage	Compressor 1			Compressor 2			OD Fan Motors (each)	Supply Blower Motor	Pwr Exh Motor	Pwr Conv Outlet	Electric Heat Field Installed Kit 2EK045*				MCA ¹ (Amps)	Min Fuse ² /Breaker ³ Size (Amps)	Max Fuse ² /Breaker ³ Size (Amps)	Min Discon-nect Rating ⁴		MCA ¹ w/Pwr Exh (Amps)	Min Fuse ² /Breaker ³ Size w/ Pwr Exh (Amps)	Max Fuse ² /Breaker ³ Size w/ Pwr Exh (Amps)	Min Discon-nect Rating ⁴ /Pwr Exh		
		RLA	LRA	MCC	RLA	LRA	MCC					Model	kW	Stages	Amps				FLA	LRA				FLA	LRA	
04 (3)	208-1-60	15.4	83.9	24				1.4	6.6	1.5		None	-	-	-	27.3	30	40	27	89	28.8	30	40	29	93	
												10625	4.9	1	23.6	37.8	40	40	35	89	39.6	40	40	36	93	
												11125	7.9	1	38	55.8	60	60	51	89	57.6	60	60	53	93	
	230-1-60	15.4	83.9	24				1.4	6	1.3			None	-	-	-	26.7	30	40	26	89	28	30	40	28	92
													10625	6.5	1	27.1	41.4	45	45	38	89	43	45	45	40	92
													11125	10.5	1	43.8	62.3	70	70	57	89	63.9	70	70	59	92
	208-3-60	10.4	73	16				1.4	6.6	1.1			None	-	-	-	21	25	30	21	78	22.1	25	30	22	81
													10625	4.9	1	13.6	25.3	30	30	23	78	26.6	30	30	24	81
													11125	7.9	1	21.9	35.6	40	40	33	78	37	40	40	34	81
													11625	12	1	33.3	49.9	50	50	46	78	51.3	60	60	47	81
	230-3-60	10.4	73	16				1.4	6	1			None	-	-	-	20.4	25	30	20	78	21.4	25	30	22	81
													10625	6.5	1	15.6	27	30	30	25	78	28.3	30	30	26	81
													11125	10.5	1	25.3	39.1	40	40	36	78	40.4	45	45	37	81
													11625	16	1	38.5	55.6	60	60	51	78	56.9	60	60	52	81
	460-3-60	5.8	38	9				0.8	3.2	0.5			None	-	-	-	11.3	15	15	11	42	11.8	15	15	12	43
													10646	6	1	7.2	13	15	15	12	42	13.6	15	15	13	43
													11146	11.5	1	13.8	21.3	25	25	20	42	21.9	25	25	20	43
													11446	14	1	16.8	25	25	25	23	42	25.6	30	30	24	43
	575-3-60	3.8	36.5	6				0.6	6	0.4			None	-	-	-	7.8	15	15	8	39	8.2	15	15	8	40
													11058	9.2	1	8.9	14.1	15	15	13	39	14.6	15	15	13	40
													11458	13.8	1	13.3	19.6	20	20	18	39	20.1	25	25	19	40
	05 (4)	208-1-60	19.6	130	31				1.4	8.4	1.5		None	-	-	-	34.3	35	50	34	135	35.8	40	50	36	139
													10625	4.9	1	23.6	40	40	50	37	135	41.9	45	50	39	139
													11125	7.9	1	38	58	60	60	53	135	59.9	60	60	55	139
230-1-60		19.6	130	31				1.4	7.6	1.3			None	-	-	-	33.5	35	50	33	135	34.8	35	50	34	138
													10625	6.5	1	27.1	43.4	45	50	40	135	45	45	50	41	138
													11125	10.5	1	43.8	64.3	70	70	59	135	65.9	70	70	61	138
208-3-60		13.7	83.1	21				1.4	8.4	1.1			None	-	-	-	26.9	30	40	27	88	28	30	40	28	91
													10625	4.9	1	13.6	27.5	30	40	27	88	28.9	30	40	28	91
													11125	7.9	1	21.9	37.9	40	40	35	88	39.3	40	40	36	91
													11625	12	1	33.3	52.1	60	60	48	88	53.5	60	60	49	91
230-3-60		13.7	83.1	21				1.4	7.6	1			None	-	-	-	26.1	30	35	26	88	27.1	30	40	27	91
													10625	6.5	1	15.6	29	30	35	27	88	30.3	35	40	28	91
													11125	10.5	1	25.3	41.1	45	45	38	88	42.4	45	45	39	91
													11625	16	1	38.5	57.6	60	60	53	88	58.9	60	60	54	91
460-3-60		6.2	41	10				0.8	4	0.5			None	-	-	-	12.6	15	15	13	45	13.1	15	15	13	46
													10646	6	1	7.2	14	15	15	13	45	14.6	15	15	13	46
													11146	11.5	1	13.8	22.3	25	25	20	45	22.9	25	25	21	46
													11446	14	1	16.8	26	30	30	24	45	26.6	30	30	24	46
575-3-60		4.8	33	8				0.6	7.6	0.4			None	-	-	-	9.6	15	15	10	35	10	15	15	10	36
													11058	9.2	1	8.9	14.9	15	15	14	35	15.4	20	20	14	36
													11458	13.8	1	13.3	20.4	25	25	19	35	20.9	25	25	19	36

ZQ04-06 Standard Static Indoor Blower - Without Powered Convenience Outlet (Continued)

Size (Tons)	Nominal Unit Voltage	Compressor 1			Compressor 2			OD Fan Motors (each)	Supply Blower Motor	Pwr Exh Motor	Pwr Conv Outlet	Electric Heat Field Installed Kit 2EK045*			MCA ¹ (Amps)	Min Fuse ² / Breaker ³ Size (Amps)	Max Fuse ² / Breaker ³ Size (Amps)	Min Disconnect Rating ⁴		MCA ¹ w/Pwr Exh (Amps)	Min Fuse ² / Breaker ³ Size w/ Pwr Exh (Amps)	Max Fuse ² / Breaker ³ Size w/ Pwr Exh (Amps)	Min Disconnect Rating ⁴ / Pwr Exh		
		RLA	LRA	MCC	RLA	LRA	MCC					Model	kW	Stages				Amps	FLA				LRA	FLA	LRA
		06 (5)	208-1-60	24.4	144	38								2.3				8.4	1.5					None	-
10625	4.9							1	23.6	41.2	45				60	40	151			42.7	45	60		42	154
11125	7.9							1	38	58	60				60	53	151			59.9	60	60		55	154
230-1-60	24.4		144	38				2.3	7.6	1.3		None	-	-	-	40.4	45	60	39	151	41.7	45	60	41	154
												10625	6.5	1	27.1	43.4	45	60	40	151	45	45	60	41	154
												11125	10.5	1	43.8	64.3	70	70	59	151	65.9	70	70	61	154
208-3-60	16		110	25				2.3	8.4	1.1		None	-	-	-	30.7	35	45	31	117	31.8	35	45	32	119
												10625	4.9	1	13.6	30.7	35	45	31	117	31.8	35	45	32	119
												11125	7.9	1	21.9	37.9	40	45	35	117	39.3	40	45	36	119
230-3-60	16		110	25				2.3	7.6	1		None	-	-	-	29.9	30	45	30	117	30.9	35	45	31	119
												10625	6.5	1	15.6	29.9	30	45	30	117	30.9	35	45	31	119
												11125	10.5	1	25.3	41.1	45	45	38	117	42.4	45	45	39	119
460-3-60	7.8		52	12				1.3	4	0.5		None	-	-	-	15.1	20	20	15	57	15.6	20	20	16	58
												10646	6	1	7.2	15.1	20	20	13	57	15.6	20	20	13	58
												11146	11.5	1	13.8	22.3	25	25	20	57	22.9	25	25	21	58
												11446	14	1	16.8	26	30	30	24	57	26.6	30	30	24	58
575-3-60	5.7		38.9	9				1.1	7.6	0.4		None	-	-	-	11.2	15	15	11	42	11.6	15	15	12	43
												11458	13.8	1	13.3	20.4	25	25	19	42	20.9	25	25	19	43
												12358	23	1	22.1	31.4	35	35	29	42	31.9	35	35	29	43

1. Minimum Circuit Ampacity.
2. Dual Element, Time Delay Type.
3. HACR type per NEC.
4. Non-fused Disconnect, Verify on the unit nameplate that the disconnect is properly sized for the application. Units with field installed electric heat kits may exceed the factory installed disconnect amperage rating.

ZQ04-06 Standard Static Indoor Blower - With Powered Convenience Outlet

Size (Tons)	Nominal Unit Voltage	Compressor 1			Compressor 2			OD Fan Motors (each)	Supply Blower Motor	Pwr Exh Motor	Pwr Conv Outlet	Electric Heat Field Installed Kit 2EK045*			MCA ¹ (Amps)	Min Fuse ² / Breaker ³ Size (Amps)	Max Fuse ² / Breaker ³ Size (Amps)	Min Discon-nect Rating ⁴		MCA ¹ w/Pwr Exh (Amps)	Min Fuse ² / Breaker ³ Size w/ Pwr Exh (Amps)	Max Fuse ² / Breaker ³ Size w/ Pwr Exh (Amps)	Min Discon-nect Rating ⁴ / Pwr Exh			
		RLA	LRA	MCC	RLA	LRA	MCC					Model	kW	Stages				Amps	FLA				LRA	FLA	LRA	
04 (3)	208-1-60	15.4	83.9	24				1.4	6.6	1.5	8.6	None	-	-	-	31.6	35	45	32	94	33.1	35	45	34	97	
												10625	4.9	1	23.6	43.1	45	45	40	94	45	45	41	97		
												11125	7.9	1	38	61.1	70	70	56	94	63	70	70	58	97	
	230-1-60	15.4	83.9	24				1.4	6	1.3	8.6	None	-	-	-	31	35	45	31	94	32.3	35	45	33	96	
												10625	6.5	1	27.1	46.8	50	50	43	94	48.4	50	50	45	96	
												11125	10.5	1	43.8	67.6	70	70	62	94	69.3	70	70	64	96	
	208-3-60	10.4	73	16				1.4	6.6	1.1	8.6	None	-	-	-	25.3	30	35	26	83	26.4	30	35	27	85	
												10625	4.9	1	13.6	30.6	35	35	28	83	32	35	35	29	85	
												11125	7.9	1	21.9	41	45	45	38	83	42.4	45	45	39	85	
	230-3-60	10.4	73	16				1.4	6	1	8.6	None	-	-	-	24.7	25	35	25	83	25.7	30	35	27	85	
												10625	6.5	1	15.6	32.4	35	35	30	83	33.6	35	35	31	85	
												11125	10.5	1	25.3	44.5	45	45	41	83	45.8	50	50	42	85	
	460-3-60	5.8	38	9				0.8	3.2	0.5	8.6	None	-	-	-	13.5	15	15	14	44	14	15	15	14	45	
												10646	6	1	7.2	15.7	20	20	14	44	16.3	20	20	15	45	
												11146	11.5	1	13.8	23.9	25	25	22	44	24.6	25	25	23	45	
	575-3-60	3.8	36.5	6				0.6	6	0.4	8.6	None	-	-	-	9.5	15	15	10	41	9.9	15	15	10	41	
												11058	9.2	1	8.9	16.3	20	20	15	41	16.8	20	20	15	41	
												11458	13.8	1	13.3	21.8	25	25	20	41	22.3	25	25	20	41	
	05 (4)	208-1-60	19.6	130	31				1.4	8.4	1.5	8.6	None	-	-	-	38.6	40	50	39	140	40.1	45	50	40	143
													10625	4.9	1	23.6	45.4	50	50	42	140	47.3	50	50	43	143
													11125	7.9	1	38	63.4	70	70	58	140	65.3	70	70	60	143
		230-1-60	19.6	130	31				1.4	7.6	1.3	8.6	None	-	-	-	37.8	40	50	38	140	39.1	40	50	39	143
													10625	6.5	1	27.1	48.8	50	50	45	140	50.4	60	60	46	143
													11125	10.5	1	43.8	69.6	70	70	64	140	71.3	80	80	66	143
208-3-60		13.7	83.1	21				1.4	8.4	1.1	8.6	None	-	-	-	31.2	35	40	32	93	32.3	35	45	33	95	
												10625	4.9	1	13.6	32.9	35	40	32	93	34.3	35	45	33	95	
												11125	7.9	1	21.9	43.3	45	45	40	93	44.6	45	45	41	95	
230-3-60		13.7	83.1	21				1.4	7.6	1	8.6	None	-	-	-	30.4	35	40	31	93	31.4	35	45	32	95	
												10625	6.5	1	15.6	34.4	35	40	32	93	35.6	40	45	33	95	
												11125	10.5	1	25.3	46.5	50	50	43	93	47.8	50	50	44	95	
460-3-60		6.2	41	10				0.8	4	0.5	8.6	None	-	-	-	14.8	15	20	15	47	15.3	20	20	16	48	
												10646	6	1	7.2	16.7	20	20	15	47	17.3	20	20	16	48	
												11146	11.5	1	13.8	24.9	25	25	23	47	25.6	30	30	24	48	
575-3-60		4.8	33	8				0.6	7.6	0.4	8.6	None	-	-	-	11.4	15	15	12	37	11.8	15	15	12	38	
												11058	9.2	1	8.9	17.1	20	20	16	37	17.6	20	20	16	38	
												11458	13.8	1	13.3	22.6	25	25	21	37	23.1	25	25	21	38	

ZQ04-06 Standard Static Indoor Blower - With Powered Convenience Outlet (Continued)

Size (Tons)	Nominal Unit Voltage	Compressor 1			Compressor 2			OD Fan Motors (each)	Supply Blower Motor	Pwr Exh Motor	Pwr Conv Outlet	Electric Heat Field Installed Kit 2EK045*				MCA ¹ (Amps)	Min Fuse ² / Breaker ³ Size (Amps)	Max Fuse ² / Breaker ³ Size (Amps)	Min Discon- nect Rating ⁴		MCA ¹ w/Pwr Exh (Amps)	Min Fuse ² / Breaker ³ Size w/ Pwr Exh (Amps)	Max Fuse ² / Breaker ³ Size w/ Pwr Exh (Amps)	Min Discon- nect Rating ⁴ / Pwr Exh	
		RLA	LRA	MCC	RLA	LRA	MCC					Model	kW	Stages	Amps				FLA	LRA				FLA	LRA
06 (5)	208-1-60	24.4	144	38				2.3	8.4	1.5	8.6	None	-	-	-	45.5	50	60	45	155	47	50	70	47	159
												10625	4.9	1	23.6	45.5	50	60	45	155	47.3	50	70	47	159
												11125	7.9	1	38	63.4	70	70	58	155	65.3	70	70	60	159
	230-1-60	24.4	144	38				2.3	7.6	1.3	8.6	None	-	-	-	44.7	45	60	44	156	46	50	70	46	158
												10625	6.5	1	27.1	48.8	50	60	45	156	50.4	60	70	46	158
												11125	10.5	1	43.8	69.6	70	70	64	156	71.3	80	80	66	158
	208-3-60	16	110	25				2.3	8.4	1.1	8.6	None	-	-	-	35	35	50	36	121	36.1	40	50	37	124
												10625	4.9	1	13.6	35	35	50	36	121	36.1	40	50	37	124
												11125	7.9	1	21.9	43.3	45	50	40	121	44.6	45	50	41	124
												11625	12	1	33.3	57.5	60	60	53	121	58.9	60	60	54	124
	230-3-60	16	110	25				2.3	7.6	1	8.6	None	-	-	-	34.2	35	50	35	121	35.2	40	50	36	124
												10625	6.5	1	15.6	34.4	35	50	35	121	35.6	40	50	36	124
												11125	10.5	1	25.3	46.5	50	50	43	121	47.8	50	50	44	124
												11625	16	1	38.5	63	70	70	58	121	64.3	70	70	59	124
	460-3-60	7.8	52	12				1.3	4	0.5	8.6	None	-	-	-	17.3	20	25	18	59	17.8	20	25	18	60
												10646	6	1	7.2	17.3	20	25	15	59	17.8	20	25	16	60
												11146	11.5	1	13.8	24.9	25	25	23	59	25.6	30	30	24	60
												11446	14	1	16.8	28.7	30	30	26	59	29.3	30	30	27	60
	575-3-60	5.7	38.9	9				1.1	7.6	0.4	8.6	None	-	-	-	13	15	15	13	44	13.4	15	15	14	45
												11458	13.8	1	13.3	22.6	25	25	21	44	23.1	25	25	21	45
												12358	23	1	22.1	33.6	35	35	31	44	34.1	35	35	31	45

1. Minimum Circuit Ampacity.
2. Dual Element, Time Delay Type.
3. HACR type per NEC.
4. Non-fused Disconnect, Verify on the unit nameplate that the disconnect is properly sized for the application. Units with field installed electric heat kits may exceed the factory installed disconnect amperage rating.

ZQ04-06 Medium Static Indoor Blower - Without Powered Convenience Outlet

Size (Tons)	Nominal Unit Voltage	Compressor 1			Compressor 2			OD Fan Motors (each)	Supply Blower Motor	Pwr Exh Motor	Pwr Conv Outlet	Electric Heat Field Installed Kit 2EK045*			MCA ¹ (Amps)	Min Fuse ² / Breaker ³ Size (Amps)	Max Fuse ² / Breaker ³ Size (Amps)	Min Discon-nect Rating ⁴		MCA ¹ w/Pwr Exh (Amps)	Min Fuse ² / Breaker ³ Size w/ Pwr Exh (Amps)	Max Fuse ² / Breaker ³ Size w/ Pwr Exh (Amps)	Min Discon-nect Rating ⁴ / Pwr Exh				
		RLA	LRA	MCC	RLA	LRA	MCC					Model	kW	Stages				Amps	FLA				LRA	FLA	LRA		
04 (3)	208-1-60	15.4	83.9	24				1.4	7.6	1.5		None	-	-	-	28.3	30	40	28	120	29.8	30	45	30	124		
												10625	4.9	1	23.6	39	40	40	36	120	40.9	45	45	38	124		
												11125	7.9	1	38	57	60	60	52	120	58.9	60	60	54	124		
	230-1-60	15.4	83.9	24				1.4	7	1.3			None	-	-	-	27.7	30	40	27	123	29	30	40	29	126	
													10625	6.5	1	27.1	42.6	45	45	39	123	44.3	45	45	41	126	
													11125	10.5	1	43.8	63.5	70	70	58	123	65.1	70	70	60	126	
	208-3-60	10.4	73	16				1.4	5.2	1.1			None	-	-	-	19.6	20	30	20	99	20.7	25	30	21	101	
													10625	4.9	1	13.6	23.5	25	30	22	99	24.9	25	30	23	101	
													11125	7.9	1	21.9	33.9	35	35	31	99	35.3	40	40	32	101	
	230-3-60	10.4	73	16				1.4	5.2	1			None	-	-	-	19.6	20	30	20	101	20.6	25	30	21	104	
													10625	6.5	1	15.6	26	30	30	24	101	27.3	30	30	25	104	
													11125	10.5	1	25.3	38.1	40	40	35	101	39.4	40	40	36	104	
	460-3-60	5.8	38	9				0.8	2.6	0.5			None	-	-	-	10.7	15	15	11	52	11.2	15	15	11	54	
													10646	6	1	7.2	12.3	15	15	11	52	12.9	15	15	12	54	
													11146	11.5	1	13.8	20.5	25	25	19	52	21.1	25	25	19	54	
	575-3-60	3.8	36.5	6				0.6	2	0.4			None	-	-	-	7.4	15	15	7	48	7.8	15	15	8	49	
													11058	9.2	1	8.9	13.6	15	15	13	48	14.1	15	15	13	49	
													11458	13.8	1	13.3	19.1	20	20	18	48	19.6	20	20	18	49	
	05 (4)	208-1-60	19.6	130	31				1.4	7.6	1.5		None	-	-	-	33.5	35	50	33	166	35	35	50	35	170	
													10625	4.9	1	23.6	39	40	50	36	166	40.9	45	50	38	170	
													11125	7.9	1	38	57	60	60	52	166	58.9	60	60	54	170	
		230-1-60	19.6	130	31				1.4	7	1.3			None	-	-	-	32.9	35	50	32	169	34.2	35	50	34	172
														10625	6.5	1	27.1	42.6	45	50	39	169	44.3	45	50	41	172
														11125	10.5	1	43.8	63.5	70	70	58	169	65.1	70	70	60	172
208-3-60		13.7	83.1	21				1.4	5.2	1.1			None	-	-	-	23.7	25	35	23	109	24.8	25	35	25	111	
													10625	4.9	1	13.6	23.7	25	35	23	109	24.9	25	35	25	111	
													11125	7.9	1	21.9	33.9	35	35	31	109	35.3	40	40	32	111	
230-3-60		13.7	83.1	21				1.4	5.2	1			None	-	-	-	23.7	25	35	23	111	24.7	25	35	24	114	
													10625	6.5	1	15.6	26	30	35	24	111	27.3	30	35	25	114	
													11125	10.5	1	25.3	38.1	40	40	35	111	39.4	40	40	36	114	
460-3-60		6.2	41	10				0.8	2.6	0.5			None	-	-	-	11.2	15	15	11	55	11.7	15	15	12	57	
													10646	6	1	7.2	12.3	15	15	11	55	12.9	15	15	12	57	
													11146	11.5	1	13.8	20.5	25	25	19	55	21.1	25	25	19	57	
575-3-60		4.8	33	8				0.6	2	0.4			None	-	-	-	8.6	15	15	9	45	9	15	15	9	45	
													11058	9.2	1	8.9	13.6	15	15	13	45	14.1	15	15	13	45	
													11458	13.8	1	13.3	19.1	20	20	18	45	19.6	20	20	18	45	

ZQ04-06 Medium Static Indoor Blower - Without Powered Convenience Outlet (Continued)

Size (Tons)	Nominal Unit Voltage	Compressor 1			Compressor 2			OD Fan Motors (each)	Supply Blower Motor	Pwr Exh Motor	Pwr Conv Outlet	Electric Heat Field Installed Kit 2EK045*			MCA ¹ (Amps)	Min Fuse ² / Breaker ³ Size (Amps)	Max Fuse ² / Breaker ³ Size (Amps)	Min Disconnect Rating ⁴		MCA ¹ w/Pwr Exh (Amps)	Min Fuse ² / Breaker ³ Size w/ Pwr Exh (Amps)	Max Fuse ² / Breaker ³ Size w/ Pwr Exh (Amps)	Min Disconnect Rating ⁴ / Pwr Exh			
		RLA	LRA	MCC	RLA	LRA	MCC					Model	kW	Stages				Amps	FLA				LRA	FLA	LRA	
06 (5)	208-1-60	24.4	144	38				2.3	7.6	1.5		None	-	-	-	40.4	45	60	39	182	41.9	45	60	41	185	
												10625	4.9	1	23.6	40.4	45	60	39	182	41.9	45	60	41	185	
												11125	7.9	1	38	57	60	60	52	182	58.9	60	60	54	185	
	230-1-60	24.4	144	38				2.3	7	1.3			None	-	-	-	39.8	40	60	39	185	41.1	45	60	40	188
													10625	6.5	1	27.1	42.6	45	60	39	185	44.3	45	60	41	188
													11125	10.5	1	43.8	63.5	70	70	58	185	65.1	70	70	60	188
	208-3-60	16	110	25				2.3	5.2	1.1			None	-	-	-	27.5	30	40	27	137	28.6	30	40	28	140
													10625	4.9	1	13.6	27.5	30	40	27	137	28.6	30	40	28	140
													11125	7.9	1	21.9	33.9	35	40	31	137	35.3	40	40	32	140
	230-3-60	16	110	25				2.3	5.2	1			None	-	-	-	27.5	30	40	27	140	28.5	30	40	28	142
													10625	6.5	1	15.6	27.5	30	40	27	140	28.5	30	40	28	142
													11125	10.5	1	25.3	38.1	40	40	35	140	39.4	40	40	36	142
	460-3-60	7.8	52	12				1.3	2.6	0.5			None	-	-	-	13.7	15	20	13	67	14.2	15	20	14	69
													10646	6	1	7.2	13.7	15	20	11	67	14.2	15	20	12	69
													11146	11.5	1	13.8	20.5	25	25	19	67	21.1	25	25	19	69
	575-3-60	5.7	38.9	9				1.1	2	0.4			None	-	-	-	10.2	15	15	10	51	10.6	15	15	11	52
													11458	13.8	1	13.3	19.1	20	20	18	51	19.6	20	20	18	52
													12358	23	1	22.1	30.1	35	35	28	51	30.6	35	35	28	52

1. Minimum Circuit Ampacity.
2. Dual Element, Time Delay Type.
3. HACR type per NEC.
4. Non-fused Disconnect, Verify on the unit nameplate that the disconnect is properly sized for the application. Units with field installed electric heat kits may exceed the factory installed disconnect ampere rating.

ZQ04-06 Medium Static Indoor Blower - With Powered Convenience Outlet

Size (Tons)	Nominal Unit Voltage	Compressor 1			Compressor 2			OD Fan Motors (each)	Supply Blower Motor	Pwr Exh Motor	Pwr Conv Outlet	Electric Heat Field Installed Kit 2EK045*				MCA ¹ (Amps)	Min Fuse ² / Breaker ³ Size (Amps)	Max Fuse ² / Breaker ³ Size (Amps)	Min Disconnect Rating ⁴		MCA ¹ w/Pwr Exh (Amps)	Min Fuse ² / Breaker ³ Size w/ Pwr Exh (Amps)	Max Fuse ² / Breaker ³ Size w/ Pwr Exh (Amps)	Min Disconnect Rating ⁴ / Pwr Exh		
		RLA	LRA	MCC	RLA	LRA	MCC					Model	kW	Stages	Amps				FLA	LRA				FLA	LRA	
04 (3)	208-1-60	15.4	83.9	24				1.4	7.6	1.5	8.6	None	-	-	-	32.6	35	45	33	125	34.1	35	45	35	128	
												10625	4.9	1	23.6	44.4	45	45	41	125	46.3	50	50	43	128	
												11125	7.9	1	38	62.4	70	70	57	125	64.3	70	70	59	128	
	230-1-60	15.4	83.9	24				1.4	7	1.3	8.6	None	-	-	-	32	35	45	32	127	33.3	35	45	34	130	
												10625	6.5	1	27.1	48	50	50	44	127	49.6	50	50	46	130	
												11125	10.5	1	43.8	68.9	70	70	63	127	70.5	80	80	65	130	
	208-3-60	10.4	73	16				1.4	5.2	1.1	8.6	None	-	-	-	23.9	25	30	24	103	25	25	35	26	106	
												10625	4.9	1	13.6	28.9	30	30	27	103	30.3	35	35	28	106	
												11125	7.9	1	21.9	39.3	40	40	36	103	40.6	45	45	37	106	
	230-3-60	10.4	73	16				1.4	5.2	1	8.6	None	-	-	-	23.9	25	30	24	106	24.9	25	35	26	108	
												10625	6.5	1	15.6	31.4	35	35	29	106	32.6	35	35	30	108	
												11125	10.5	1	25.3	43.5	45	45	40	106	44.8	45	45	41	108	
	460-3-60	5.8	38	9				0.8	2.6	0.5	8.6	None	-	-	-	12.9	15	15	13	55	13.4	15	15	14	56	
												10646	6	1	7.2	14.9	15	15	14	55	15.6	20	20	14	56	
												11146	11.5	1	13.8	23.2	25	25	21	55	23.8	25	25	22	56	
	575-3-60	3.8	36.5	6				0.6	2	0.4	8.6	None	-	-	-	9.1	15	15	9	50	9.5	15	15	10	51	
												11058	9.2	1	8.9	15.8	20	20	15	50	16.3	20	20	15	51	
												11458	13.8	1	13.3	21.3	25	25	20	50	21.8	25	25	20	51	
	05 (4)	208-1-60	19.6	130	31				1.4	7.6	1.5	8.6	None	-	-	-	37.8	40	50	38	171	39.3	40	50	40	174
													10625	4.9	1	23.6	44.4	45	50	41	171	46.3	50	50	43	174
													11125	7.9	1	38	62.4	70	70	57	171	64.3	70	70	59	174
		230-1-60	19.6	130	31				1.4	7	1.3	8.6	None	-	-	-	37.2	40	50	37	173	38.5	40	50	39	176
													10625	6.5	1	27.1	48	50	50	44	173	49.6	50	50	46	176
													11125	10.5	1	43.8	68.9	70	70	63	173	70.5	80	80	65	176
208-3-60		13.7	83.1	21				1.4	5.2	1.1	8.6	None	-	-	-	28	30	40	28	113	29.1	30	40	30	116	
												10625	4.9	1	13.6	28.9	30	40	28	113	30.3	35	40	30	116	
												11125	7.9	1	21.9	39.3	40	40	36	113	40.6	45	45	37	116	
230-3-60		13.7	83.1	21				1.4	5.2	1	8.6	None	-	-	-	28	30	40	28	116	29	30	40	29	118	
												10625	6.5	1	15.6	31.4	35	40	29	116	32.6	35	40	30	118	
												11125	10.5	1	25.3	43.5	45	45	40	116	44.8	45	45	41	118	
460-3-60		6.2	41	10				0.8	2.6	0.5	8.6	None	-	-	-	13.4	15	15	14	58	13.9	15	15	14	59	
												10646	6	1	7.2	14.9	15	15	14	58	15.6	20	20	14	59	
												11146	11.5	1	13.8	23.2	25	25	21	58	23.8	25	25	22	59	
575-3-60		4.8	33	8				0.6	2	0.4	8.6	None	-	-	-	10.3	15	15	10	46	10.7	15	15	11	47	
												11058	9.2	1	8.9	15.8	20	20	15	46	16.3	20	20	15	47	
												11458	13.8	1	13.3	21.3	25	25	20	46	21.8	25	25	20	47	

ZQ04-06 Medium Static Indoor Blower - With Powered Convenience Outlet (Continued)

Size (Tons)	Nominal Unit Voltage	Compressor 1			Compressor 2			OD Fan Motors (each)	Supply Blower Motor	Pwr Exh Motor	Pwr Conv Outlet	Electric Heat Field Installed Kit 2EK045*				MCA ¹ (Amps)	Min Fuse ^{2/} Breaker ³ Size (Amps)	Max Fuse ^{2/} Breaker ³ Size (Amps)	Min Disconnect Rating ⁴		MCA ¹ w/Pwr Exh (Amps)	Min Fuse ^{2/} Breaker ³ Size w/ Pwr Exh (Amps)	Max Fuse ^{2/} Breaker ³ Size w/ Pwr Exh (Amps)	Min Disconnect Rating ⁴ / Pwr Exh	
		RLA	LRA	MCC	RLA	LRA	MCC					Model	kW	Stages	Amps				FLA	LRA				FLA	LRA
		06 (5)	208-1-60	24.4	144	38								2.3	7.6				1.5	8.6				None	-
10625	4.9							1	23.6	44.7	45					60	44	186			46.3	50	70	46	190
11125	7.9							1	38	62.4	70					70	57	186			64.3	70	70	59	190
230-1-60	24.4		144	38				2.3	7	1.3	8.6	None	-	-	-	44.1	45	60	44	189	45.4	50	60	45	192
												10625	6.5	1	27.1	48	50	60	44	189	49.6	50	60	46	192
												11125	10.5	1	43.8	68.9	70	70	63	189	70.5	80	80	65	192
208-3-60	16		110	25				2.3	5.2	1.1	8.6	None	-	-	-	31.8	35	45	32	142	32.9	35	45	33	144
												10625	4.9	1	13.6	31.8	35	45	32	142	32.9	35	45	33	144
												11125	7.9	1	21.9	39.3	40	45	36	142	40.6	45	45	37	144
230-3-60	16		110	25				2.3	5.2	1	8.6	None	-	-	-	31.8	35	45	32	144	32.8	35	45	33	147
												10625	6.5	1	15.6	31.8	35	45	32	144	32.8	35	45	33	147
												11125	10.5	1	25.3	43.5	45	45	40	144	44.8	45	45	41	147
460-3-60	7.8		52	12				1.3	2.6	0.5	8.6	None	-	-	-	15.9	20	20	16	70	16.4	20	20	17	71
												10646	6	1	7.2	15.9	20	20	14	70	16.4	20	20	14	71
												11146	11.5	1	13.8	23.2	25	25	21	70	23.8	25	25	22	71
575-3-60	5.7		38.9	9				1.1	2	0.4	8.6	None	-	-	-	11.9	15	15	12	53	12.3	15	15	13	54
												11458	13.8	1	13.3	21.3	25	25	20	53	21.8	25	25	20	54
												12358	23	1	22.1	32.3	35	35	30	53	32.8	35	35	30	54

1. Minimum Circuit Ampacity.
2. Dual Element, Time Delay Type.
3. HACR type per NEC.
4. Non-fused Disconnect, Verify on the unit nameplate that the disconnect is properly sized for the application. Units with field installed electric heat kits may exceed the factory installed disconnect amperage rating.

ZQ04-06 Hi Static Indoor Blower - Without Powered Convenience Outlet

Size (Tons)	Nominal Unit Voltage	Compressor 1			Compressor 2			OD Fan Motors (each)	Supply Blower Motor	Pwr Exh Motor	Pwr Conv Outlet	Electric Heat Field Installed Kit 2EK045*				MCA ¹ (Amps)	Min Fuse ² /Breaker ³ Size (Amps)	Max Fuse ² /Breaker ³ Size (Amps)	Min Disconnect Rating ⁴		MCA ¹ w/Pwr Exh (Amps)	Min Fuse ² /Breaker ³ Size w/ Pwr Exh (Amps)	Max Fuse ² /Breaker ³ Size w/ Pwr Exh (Amps)	Min Disconnect Rating ⁴ / Pwr Exh		
		RLA	LRA	MCC	RLA	LRA	MCC					Model	kW	Stages	Amps				FLA	LRA				FLA	LRA	
04 (3)	208-3-60	10.4	73	16				1.4	5.2	1.1		None	-	-	-	19.6	20	30	20	99	20.7	25	30	21	101	
												10625	4.9	1	13.6	23.5	25	30	22	99	24.9	25	30	23	101	
												11125	7.9	1	21.9	33.9	35	35	31	99	35.3	40	40	32	101	
												11625	12	1	33.3	48.1	50	50	44	99	49.5	50	50	46	101	
	230-3-60	10.4	73	16				1.4	5.2	1			None	-	-	-	19.6	20	30	20	101	20.6	25	30	21	104
													10625	6.5	1	15.6	26	30	30	24	101	27.3	30	30	25	104
													11125	10.5	1	25.3	38.1	40	40	35	101	39.4	40	40	36	104
													11625	16	1	38.5	54.6	60	60	50	101	55.9	60	60	51	104
	460-3-60	5.8	38	9				0.8	2.6	0.5			None	-	-	-	10.7	15	15	11	52	11.2	15	15	11	54
													10646	6	1	7.2	12.3	15	15	11	52	12.9	15	15	12	54
													11146	11.5	1	13.8	20.5	25	25	19	52	21.1	25	25	19	54
													11446	14	1	16.8	24.3	25	25	22	52	24.9	25	25	23	54
575-3-60	3.8	36.5	6				0.6	2	0.4			None	-	-	-	7.4	15	15	7	48	7.8	15	15	8	49	
												11058	9.2	1	8.9	13.6	15	15	13	48	14.1	15	15	13	49	
												11458	13.8	1	13.3	19.1	20	20	18	48	19.6	20	20	18	49	
05 (4)	208-3-60	13.7	83.1	21				1.4	5.2	1.1		None	-	-	-	23.7	25	35	23	109	24.8	25	35	25	111	
												10625	4.9	1	13.6	23.7	25	35	23	109	24.9	25	35	25	111	
												11125	7.9	1	21.9	33.9	35	35	31	109	35.3	40	40	32	111	
												11625	12	1	33.3	48.1	50	50	44	109	49.5	50	50	46	111	
	230-3-60	13.7	83.1	21				1.4	5.2	1			None	-	-	-	23.7	25	35	23	111	24.7	25	35	24	114
													10625	6.5	1	15.6	26	30	35	24	111	27.3	30	35	25	114
													11125	10.5	1	25.3	38.1	40	40	35	111	39.4	40	40	36	114
													11625	16	1	38.5	54.6	60	60	50	111	55.9	60	60	51	114
	460-3-60	6.2	41	10				0.8	2.6	0.5			None	-	-	-	11.2	15	15	11	55	11.7	15	15	12	57
													10646	6	1	7.2	12.3	15	15	11	55	12.9	15	15	12	57
													11146	11.5	1	13.8	20.5	25	25	19	55	21.1	25	25	19	57
													11446	14	1	16.8	24.3	25	25	22	55	24.9	25	25	23	57
575-3-60	4.8	33	8				0.6	2	0.4			None	-	-	-	8.6	15	15	9	45	9	15	15	9	45	
												11058	9.2	1	8.9	13.6	15	15	13	45	14.1	15	15	13	45	
												11458	13.8	1	13.3	19.1	20	20	18	45	19.6	20	20	18	45	
06 (5)	208-3-60	16	110	25				2.3	7.5	1.1		None	-	-	-	29.8	30	45	30	163	30.9	35	45	31	166	
												10625	4.9	1	13.6	29.8	30	45	30	163	30.9	35	45	31	166	
												11125	7.9	1	21.9	36.8	40	45	34	163	38.1	40	45	35	166	
												11625	12	1	33.3	51	60	60	47	163	52.4	60	60	48	166	
	230-3-60	16	110	25				2.3	7.5	1			None	-	-	-	29.8	30	45	30	170	30.8	35	45	31	172
													10625	6.5	1	15.6	29.8	30	45	30	170	30.8	35	45	31	172
													11125	10.5	1	25.3	41	45	45	38	170	42.3	45	45	39	172
													11625	16	1	38.5	57.5	60	60	53	170	58.8	60	60	54	172
	460-3-60	7.8	52	12				1.3	3.4	0.5			None	-	-	-	14.5	15	20	14	82	15	15	20	15	84
													10646	6	1	7.2	14.5	15	20	12	82	15	15	20	13	84
													11146	11.5	1	13.8	21.5	25	25	20	82	22.1	25	25	20	84
													11446	14	1	16.8	25.3	30	30	23	82	25.9	30	30	24	84
575-3-60	5.7	38.9	9				1.1	2.8	0.4			None	-	-	-	11	15	15	11	63	11.4	15	15	12	64	
												11458	13.8	1	13.3	20.1	25	25	19	63	20.6	25	25	19	64	
												12358	23	1	22.1	31.1	35	35	29	63	31.6	35	35	29	64	

1. Minimum Circuit Ampacity.
2. Dual Element, Time Delay Type.
3. HACR type per NEC.
4. Non-fused Disconnect, Verify on the unit nameplate that the disconnect is properly sized for the application. Units with field installed electric heat kits may exceed the factory installed disconnect amperage rating.

ZQ04-06 Hi Static Indoor Blower - With Powered Convenience Outlet

Size (Tons)	Nominal Unit Voltage	Compressor 1			Compressor 2			OD Fan Motors (each)	Supply Blower Motor	Pwr Exh Motor	Pwr Conv Outlet	Electric Heat Field Installed Kit 2EK045*				MCA ¹ (Amps)	Min Fuse ² /Breaker ³ Size (Amps)	Max Fuse ² /Breaker ³ Size (Amps)	Min Disconnect Rating ⁴		MCA ¹ w/Pwr Exh (Amps)	Min Fuse ² /Breaker ³ Size w/ Pwr Exh (Amps)	Max Fuse ² /Breaker ³ Size w/ Pwr Exh (Amps)	Min Disconnect Rating ⁴ / Pwr Exh	
		RLA	LRA	MCC	RLA	LRA	MCC					Model	kW	Stages	Amps				FLA	LRA				FLA	LRA
04 (3)	208-3-60	10.4	73	16				1.4	5.2	1.1	8.6	None	-	-	-	23.9	25	30	24	103	25	25	35	26	106
												10625	4.9	1	13.6	28.9	30	30	27	103	30.3	35	35	28	106
												11125	7.9	1	21.9	39.3	40	40	36	103	40.6	45	45	37	106
												11625	12	1	33.3	53.5	60	60	49	103	54.9	60	60	50	106
	230-3-60	10.4	73	16				1.4	5.2	1	8.6	None	-	-	-	23.9	25	30	24	106	24.9	25	35	26	108
												10625	6.5	1	15.6	31.4	35	35	29	106	32.6	35	35	30	108
												11125	10.5	1	25.3	43.5	45	45	40	106	44.8	45	45	41	108
												11625	16	1	38.5	60	60	60	55	106	61.3	70	70	56	108
	460-3-60	5.8	38	9				0.8	2.6	0.5	8.6	None	-	-	-	12.9	15	15	13	55	13.4	15	15	14	56
												10646	6	1	7.2	14.9	15	15	14	55	15.6	20	20	14	56
												11146	11.5	1	13.8	23.2	25	25	21	55	23.8	25	25	22	56
												11446	14	1	16.8	26.9	30	30	25	55	27.6	30	30	25	56
575-3-60	3.8	36.5	6				0.6	2	0.4	8.6	None	-	-	-	9.1	15	15	9	50	9.5	15	15	10	51	
											11058	9.2	1	8.9	15.8	20	20	15	50	16.3	20	20	15	51	
											11458	13.8	1	13.3	21.3	25	25	20	50	21.8	25	25	20	51	
											None	-	-	-	28	30	40	28	113	29.1	30	40	30	116	
05 (4)	208-3-60	13.7	83.1	21				1.4	5.2	1.1	8.6	None	-	-	-	28	30	40	28	113	29.1	30	40	30	116
												10625	4.9	1	13.6	28.9	30	40	28	113	30.3	35	40	30	116
												11125	7.9	1	21.9	39.3	40	40	36	113	40.6	45	45	37	116
												11625	12	1	33.3	53.5	60	60	49	113	54.9	60	60	50	116
	230-3-60	13.7	83.1	21				1.4	5.2	1	8.6	None	-	-	-	28	30	40	28	116	29	30	40	29	118
												10625	6.5	1	15.6	31.4	35	40	29	116	32.6	35	40	30	118
												11125	10.5	1	25.3	43.5	45	45	40	116	44.8	45	45	41	118
												11625	16	1	38.5	60	60	60	55	116	61.3	70	70	56	118
	460-3-60	6.2	41	10				0.8	2.6	0.5	8.6	None	-	-	-	13.4	15	15	14	58	13.9	15	15	14	59
												10646	6	1	7.2	14.9	15	15	14	58	15.6	20	20	14	59
												11146	11.5	1	13.8	23.2	25	25	21	58	23.8	25	25	22	59
												11446	14	1	16.8	26.9	30	30	25	58	27.6	30	30	25	59
575-3-60	4.8	33	8				0.6	2	0.4	8.6	None	-	-	-	10.3	15	15	10	46	10.7	15	15	11	47	
											11058	9.2	1	8.9	15.8	20	20	15	46	16.3	20	20	15	47	
											11458	13.8	1	13.3	21.3	25	25	20	46	21.8	25	25	20	47	
											None	-	-	-	34.1	35	50	35	168	35.2	40	50	36	170	
06 (5)	208-3-60	16	110	25				2.3	7.5	1.1	8.6	None	-	-	-	34.1	35	50	35	168	35.2	40	50	36	170
												10625	4.9	1	13.6	34.1	35	50	35	168	35.2	40	50	36	170
												11125	7.9	1	21.9	42.1	45	50	39	168	43.5	45	50	40	170
												11625	12	1	33.3	56.4	60	60	52	168	57.8	60	60	53	170
	230-3-60	16	110	25				2.3	7.5	1	8.6	None	-	-	-	34.1	35	50	35	174	35.1	40	50	36	177
												10625	6.5	1	15.6	34.3	35	50	35	174	35.5	40	50	36	177
												11125	10.5	1	25.3	46.4	50	50	43	174	47.6	50	50	44	177
												11625	16	1	38.5	62.9	70	70	58	174	64.1	70	70	59	177
	460-3-60	7.8	52	12				1.3	3.4	0.5	8.6	None	-	-	-	16.7	20	20	17	85	17.2	20	20	17	86
												10646	6	1	7.2	16.7	20	20	15	85	17.2	20	20	15	86
												11146	11.5	1	13.8	24.2	25	25	22	85	24.8	25	25	23	86
												11446	14	1	16.8	27.9	30	30	26	85	28.6	30	30	26	86
575-3-60	5.7	38.9	9				1.1	2.8	0.4	8.6	None	-	-	-	12.7	15	15	13	65	13.1	15	15	13	66	
											11458	13.8	1	13.3	22.3	25	25	20	65	22.8	25	25	21	66	
											12358	23	1	22.1	33.3	35	35	31	65	33.8	35	35	31	66	
											None	-	-	-	23.9	25	30	24	103	25	25	35	26	106	

1. Minimum Circuit Ampacity.
2. Dual Element, Time Delay Type.
3. HACR type per NEC.
4. Non-fused Disconnect, Verify on the unit nameplate that the disconnect is properly sized for the application. Units with field installed electric heat kits may exceed the factory installed disconnect amperage rating.

Table 8: Physical Data

ZQ04 Physical Data

Component		Models			
		ZQG04		ZQE04	
Nominal Tonnage		3		3	
AHRI COOLING PERFORMANCE	Gross Capacity @ AHRI A point (Btu)	38,100		38,100	
	AHRI net capacity (Btu)	35,000		35,000	
	EER	12.2		12.2	
	SEER	14		14	
	IEER	-		-	
	Nominal CFM	1200		1200	
	System power (KW)	2.8		2.8	
	Refrigerant type	R-410A		R-410A	
	Refrigerant charge (lb-oz)				
	System 1	3-6		3-6	
System 2	-		-		
AHRI HEATING PERFORMANCE SINGLE PHASE	Heating Option	L	D	M	E
	Heating Model	Low (Low-NOx)	Low	Med (Low-NOx)	Med
	1st. Stage Heat input (K Btu)	-	-	-	-
	2nd. Stage Heat input (K Btu)	56	70	90	112
	1st. Stage Heat output (K Btu)	-	-	-	-
	2nd. Stage Heat output (K Btu)	45	56	72	90
	AFUE %	81	81	81	81
	No. burners	2	2	3	3
	No. stages	1	1	1	1
	Temperature Rise Range (°F)	10-40	20-50	35-65	50-80
	Gas Limit Setting (°F)	150	150	140	140
	Gas piping connection (in.)	1/2	1/2	1/2	1/2
AHRI HEATING PERFORMANCE THREE PHASE	Heating Option	L	D	M	E
	Heating Model	Low (Low-NOx)	Low	Med (Low-NOx)	Med
	1st. Stage Heat input (K Btu)	-	-	-	82
	2nd. Stage Heat input (K Btu)	56	70	90	112
	1st. Stage Heat output (K Btu)	-	-	-	66
	2nd. Stage Heat output (K Btu)	45	56	72	90
	Steady state efficiency (%)	80	80	80	80
	No. burners	2	2	3	3
	No. stages	1	1	1	2
	Temperature Rise Range (°F)	28-46	35-58	44-74	55-78
	Gas Limit Setting (°F)	150	150	140	140
	Gas piping connection (in.)	1/2	1/2	1/2	1/2
DIMENSIONS (inches)	Length	74.1		74.1	
	Width	48.9		48.9	
	Height	32.5		32.5	
OPERATING WT. (lbs.)	498		450		
COMPRESSORS	Type	Scroll		Scroll	
	Quantity	1		1	
	Unit Capacity Steps (%)	100		100	

ZQ04 Physical Data

Component		Models			
		ZQG04	ZQE04		
Nominal Tonnage		3	3		
CONDENSER COIL DATA	Face area (Sq. Ft.)	16.3	16.3		
	Rows	1	1		
	Fins per inch	23	23		
	Tube diameter (in./MM)	.63/16	.63/16		
	Circuitry Type	2-pass Microchannel	2-pass Microchannel		
EVAPORATOR COIL DATA	Face area (Sq. Ft.)	5.5	5.5		
	Rows	2	2		
	Fins per inch	15	15		
	Tube diameter	0.375	0.375		
	Circuitry Type	Intertwined	Intertwined		
	Refrigerant control	Orifice	Orifice		
CONDENSER FAN DATA	Quantity of fans	1	1		
	Fan diameter (Inch)	22	22		
	Type	Prop	Prop		
	Drive type	Direct	Direct		
	Quantity of motors	1	1		
	Motor HP each	1/4	1/4		
	No. speeds	1	1		
	RPM	1100	1100		
Nominal total CFM		3800	3800		
EVAP FAN DATA - DIRECT DRIVE	Airflow Option	A	A		
	Quantity	1	1		
	Fan Size (Inch)	10 x 10	10 x 10		
	Type	Centrifugal	Centrifugal		
	Motor HP	3/4	3/4		
	Motor RPM	1050	1050		
EVAP FAN DATA - BELT DRIVE	Airflow Option	B	C	B	C
	Quantity	1	1	1	1
	Fan Size (Inch)	10 x 10	10 x 10	10 x 10	10 x 10
	Type	Centrifugal	Centrifugal	Centrifugal	Centrifugal
	Motor Sheave	1VL34	1VL44	1VL34	1VL44
	Blower Sheave	AK46	AK46	AK46	AK46
	Belt	A39	A40	A39	A40
	Motor HP, 1-phase	1.5	--	1.5	--
	Frame size, 1-phase	56HZ	--	56HZ	--
	Motor HP, 3-phase	2.4	2.4	2.4	2.4
	Frame size, 3-phase	56Y	56Y	56Y	56Y
	Motor RPM	1725	1725	1725	1725
FILTERS	Quantity - Size	2 - (16 x 25 x 2) ¹		2 - (16 x 25 x 2) ¹	

1. 2 In. Throwaway, Standard, MERV (Minimum Efficiency Reporting Value) 3

ZQ05 Physical Data

Component	Models							Models	
	ZQG05							ZQE05	
Nominal Tonnage	4							4	
AHRI COOLING PERFORMANCE	Gross Capacity @ AHRI A point (Btu)	51,300							51,300
	AHRI net capacity (Btu)	48,000							48,000
	EER	12							12
	SEER	14							14
	IEER	-							-
	Nominal CFM	1575							1575
	System power (KW)	4							4
	Refrigerant type	R-410A							R-410A
	Refrigerant charge (lb-oz)								
	System 1	4-6							4-6
System 2	-							-	
AHRI HEATING PERFORMANCE SINGLE PHASE	Heating Option	L	D	M	E	N	F		
	Heating Model	Low (Low-NOx)	Low	Med (Low-NOx)	Med	High, (Low-NOx)	High		
	1st. Stage Heat input (K Btu)	-	-	-	-	-	-		
	2nd. Stage Heat input (K Btu)	56	70	90	112	116	142		
	1st. Stage Heat output (K Btu)	-	-	-	-	-	-		
	2nd. Stage Heat output (K Btu)	45	56	72	90	93	114		
	AFUE %	81	81	81	81	81	81		
	No. burners	2	2	3	3	3	3		
	No. stages	1	1	1	1	1	1		
	Temperature Rise Range (°F)	05-35	15-45	25-55	40-70	35-65	45-75		
	Gas Limit Setting (°F)	150	150	140	140	150	145		
Gas piping connection (in.)	1/2	1/2	1/2	1/2	1/2	1/2			
AHRI HEATING PERFORMANCE THREE PHASE	Heating Option	L	D	M	E	N	F		
	Heating Model	Low (Low-NOx)	Low	Med (Low-NOx)	Med	High, (Low-NOx)	High		
	1st. Stage Heat input (K Btu)	-	-	-	-	-	100		
	2nd. Stage Heat input (K Btu)	56	70	90	112	118	145		
	1st. Stage Heat output (K Btu)	-	-	-	-	-	80		
	2nd. Stage Heat output (K Btu)	45	56	72	90	94	116		
	Steady state efficiency (%)	80	80	80	80	80	80		
	No. burners	2	2	3	3	3	3		
	No. stages	1	1	1	1	1	2		
	Temperature Rise Range (°F)	21-35	26-43	33-56	41-69	44-73	49-77		
	Gas Limit Setting (°F)	150	150	140	140	150	145		
Gas piping connection (in.)	1/2	1/2	1/2	1/2	1/2	1/2			
DIMENSIONS (inches)	Length	74.1							74.1
	Width	48.9							48.9
	Height	32.5							32.5
OPERATING WT. (lbs.)	538							487	
COMPRESSORS	Type	Scroll							Scroll
	Quantity	1							1
	Unit Capacity Steps (%)	100							100
CONDENSER COIL DATA	Face area (Sq. Ft.)	16.3							16.3
	Rows	1							1
	Fins per inch	23							23
	Tube diameter (in./MM)	.63/16							.63/16
	Circuitry Type	2-pass Microchannel							2-pass Microchannel

ZQ05 Physical Data

Component	Models			
	ZQG05	ZQE05		
Nominal Tonnage	4	4		
EVAPORATOR COIL DATA				
Face area (Sq. Ft.)	5.5	5.5		
Rows	3	3		
Fins per inch	15	15		
Tube diameter	0.375	0.375		
Circuitry Type	Intertwined	Intertwined		
Refrigerant control	Orifice	Orifice		
CONDENSER FAN DATA				
Quantity of fans	1	1		
Fan diameter (Inch)	22	22		
Type	Prop	Prop		
Drive type	Direct	Direct		
Quantity of motors	1	1		
Motor HP each	1/4	1/4		
No. speeds	1	1		
RPM	1100	1100		
Nominal total CFM	3800	3800		
EVAP FAN DATA - DIRECT DRIVE				
Airflow Option	A	A		
Quantity	1	1		
Fan Size (Inch)	10 x 10	10 x 10		
Type	Centrifugal	Centrifugal		
Motor HP	1	1		
Motor RPM	1050	1050		
EVAP FAN DATA - BELT DRIVE				
Airflow Option	B	C	B	C
Quantity	1	1	1	1
Fan Size (Inch)	10 x 10	10 x 10	10 x 10	10 x 10
Type	Centrifugal	Centrifugal	Centrifugal	Centrifugal
Motor Sheave	1VL34	1VL44	1VL34	1VL44
Blower Sheave	AK46	AK46	AK46	AK46
Belt	A39	A40	A39	A40
Motor HP, 1-phase	1.5	--	1.5	--
Frame size, 1-phase	56HZ	--	56HZ	--
Motor HP, 3-phase	2.4	2.4	2.4	2.4
Frame size, 3-phase	56Y	56Y	56Y	56Y
Motor RPM	1725	1725	1725	1725
FILTERS	Quantity - Size	2 - (16 x 25 x 2) ¹		2 - (16 x 25 x 2) ¹

1. 2 In. Throwaway, Standard, MERV (Minimum Efficiency Reporting Value) 3

ZQ06 Physical Data

Component	Models							Models	
	ZQG06							ZQE06	
Nominal Tonnage	5							5	
AHRI COOLING PERFORMANCE	Gross Capacity @ AHRI A point (Btu)	64,200							64,200
	AHRI net capacity (Btu)	58,500							58,500
	EER	12.1							12.1
	SEER	14.1							14.1
	IEER	-							-
	Nominal CFM	1950							1950
	System power (KW)	4.8							4.8
	Refrigerant type	R-410A							R-410A
	Refrigerant charge (lb-oz)								
	System 1	5-14							5-14
	System 2	-							-
AHRI HEATING PERFORMANCE SINGLE PHASE	Heating Option	L	D	M	E	N	F		
	Heating Model	Low (Low-NOx)	Low	Med (Low-NOx)	Med	High, (Low-NOx)	High		
	1st. Stage Heat input (K Btu)	-	-	-	-	-	-		
	2nd. Stage Heat input (K Btu)	56	70	90	112	116	142		
	1st. Stage Heat output (K Btu)	-	-	-	-	-	-		
	2nd. Stage Heat output (K Btu)	45	56	72	90	93	114		
	AFUE %	81	81	81	81	81	81		
	No. burners	2	2	3	3	3	3		
	No. stages	1	1	1	1	1	1		
	Temperature Rise Range (°F)	05-35	10-40	15-45	30-60	30-60	40-70		
	Gas Limit Setting (°F)	150	150	140	140	145	140		
Gas piping connection (in.)	1/2	1/2	1/2	1/2	1/2	1/2			
AHRI HEATING PERFORMANCE THREE PHASE	Heating Option	L	D	M	E	N	F		
	Heating Model	Low (Low-NOx)	Low	Med (Low-NOx)	Med	High, (Low-NOx)	High		
	1st. Stage Heat input (K Btu)	-	-	-	-	-	100		
	2nd. Stage Heat input (K Btu)	56	70	90	112	118	145		
	1st. Stage Heat output (K Btu)	-	-	-	-	-	80		
	2nd. Stage Heat output (K Btu)	45	56	72	90	94	116		
	Steady state efficiency (%)	80	80	80	80	80	80		
	No. burners	2	2	3	3	3	3		
	No. stages	1	1	1	1	1	2		
	Temperature Rise Range (°F)	17-28	21-35	27-44	33-55	35-58	43-72		
	Gas Limit Setting (°F)	150	150	140	140	145	140		
Gas piping connection (in.)	1/2	1/2	1/2	1/2	1/2	1/2			
DIMENSIONS (inches)	Length	74.1							74.1
	Width	48.9							48.9
	Height	40.6							40.6
OPERATING WT. (lbs.)	615							566	
COMPRESSORS	Type	Scroll							Scroll
	Quantity	1							1
	Unit Capacity Steps (%)	100							100
CONDENSER COIL DATA	Face area (Sq. Ft.)	21.1							21.1
	Rows	1							1
	Fins per inch	23							23
	Tube diameter (in./MM)	.79/20							.79/20
	Circuitry Type	2-pass Microchannel							2-pass Microchannel

ZQ06 Physical Data

Component	Models			
	ZQG06	ZQE06		
Nominal Tonnage	5	5		
EVAPORATOR COIL DATA				
Face area (Sq. Ft.)	7.3	7.3		
Rows	3	3		
Fins per inch	15	15		
Tube diameter	0.375	0.375		
Circuitry Type	Intertwined	Intertwined		
Refrigerant control	Orifice	Orifice		
CONDENSER FAN DATA				
Quantity of fans	1	1		
Fan diameter (Inch)	22	22		
Type	Prop	Prop		
Drive type	Direct	Direct		
Quantity of motors	1	1		
Motor HP each	1/2	1/2		
No. speeds	1	1		
RPM	1085	1085		
Nominal total CFM	4600	4600		
EVAP FAN DATA - DIRECT DRIVE				
Airflow Option	A	A		
Quantity	1	1		
Fan Size (Inch)	11 x 10	11 x 10		
Type	Centrifugal	Centrifugal		
Motor HP	1	1		
Motor RPM	1050	1050		
EVAP FAN DATA - BELT DRIVE				
Airflow Option	B	C	B	C
Quantity	1	1	1	1
Fan Size (Inch)	11 x 10	11 x 10	11 x 10	11 x 10
Type	Centrifugal	Centrifugal	Centrifugal	Centrifugal
Motor Sheave	1VL34	1VL44	1VL34	1VL44
Blower Sheave	AK46	AK46	AK46	AK46
Belt	A37	A39	A37	A39
Motor HP, 1-phase	1.5	--	1.5	--
Frame size, 1-phase	56HZ	--	56HZ	--
Motor HP, 3-phase	2.4	2.9	2.4	2.9
Frame size, 3-phase	56Y	56HZ	56Y	56HZ
Motor RPM	1725	1725	1725	1725
FILTERS	Quantity - Size	4 - (16 x 16 x 2) ¹		4 - (16 x 16 x 2) ¹

1. 2 In. Throwaway, Standard, MERV (Minimum Efficiency Reporting Value) 3

Optional Gas Heat

These gas-fired heaters have aluminized-steel or optional stainless steel, tubular heat exchangers with spark ignition.

Gas Piping

Proper sizing of gas piping depends on the cubic feet per hour of gas flow required, specific gravity of the gas and the length of run. "National Fuel Gas Code" Z223.1 (in U.S.A.) or the current Gas Installation Codes CSA-B149.1 (in Canada) should be followed in all cases unless superseded by local codes or gas utility requirements. Refer to the Pipe Sizing Table 9. The heating value of the gas may differ with locality. The value should be checked with the local gas utility.

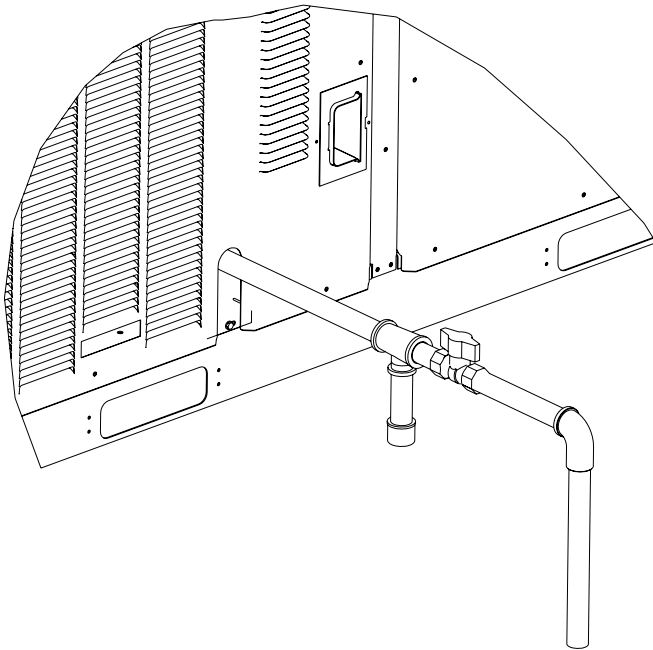

Figure 15: Side Entry Gas Piping

NOTE: Routing of gas piping must not interfere with the flue or heat compartment access.

Table 9: Gas Pipe Sizing - Capacity of Pipe

Length of Pipe (ft.)	Nominal Iron Pipe Size		
	3/4 in.	1 in.	1-1/4 in.
10	278	520	1050
20	190	350	730
30	152	285	590
40	130	245	500
50	115	215	440
60	105	195	400
70	96	180	370
80	90	170	350
90	84	160	320
100	79	150	305

NOTE: Maximum capacity of pipe in cubic feet of gas per hour based upon a pressure drop of 0.3 inch W.C. and 0.6 specific gravity gas.

NOTE: There may be a local gas utility requirement specifying a minimum diameter for gas piping. Units require either a 1/2 or 3/4 inch pipe connection at the entrance fitting. Line should not be sized smaller than the entrance fitting size.

Table 10: Gas Heat Supply Air

Model (Size)	Gas Heat Description	Opt.	Supply Air (CFM)	
			Heating	
			Min	Max
ZQ04 (3)	Low, NOx	L	900	1480
	Low	D	890	1480
	Med, NOx	M	900	1520
	Med	E	1060	1510
ZQ05 (4)	Low, NOx	L	1190	1980
	Low	D	1210	1990
	Med, NOx	M	1190	2020
	Med	E	1200	2020
	High, NOx	N	1200	1990
	High	F	1390	2190
ZQ06 (5)	Low, NOx	L	1480	2440
	Low	D	1480	2470
	Med, NOx	M	1520	2470
	Med	E	1510	2510
	High, NOx	N	1510	2500
	High	F	1490	2500

Gas Connection

The gas supply line can be routed within the space and roof curb, exiting through the unit's basepan. Refer to Figures 7 and 8 for the gas piping inlet location. Typical supply piping arrangements are shown in Figure 15. All pipe nipples, fittings, and the gas cock are field supplied.

Gas piping recommendations:

1. A drip leg and a ground joint union must be installed in the gas piping.
2. Where required by local codes, a manual shut-off valve must be installed outside of the unit.
3. Use wrought iron or steel pipe for all gas lines. Pipe dope should be applied sparingly to male threads only. If local codes allow the use of a flexible gas appliance connector, always use a new listed connector. Do not use a connector which has previously serviced another gas appliance.

▲ WARNING

Natural gas may contain some propane. Propane is an excellent solvent and will quickly dissolve white lead and most standard commercial compounds. A special pipe dope must be used when assembling wrought iron or steel pipe. Shellac based compounds such as Gaskolac or Stalastic, and compounds such as Rectorseal #5, Clydes's or John Crane may be used.

4. All piping should be cleaned of dirt and scale by hammering on the outside of the pipe and blowing out loose particles. Before initial start-up, be sure that all gas lines external to the unit have been purged of air.
5. The gas supply should be a separate line and installed in accordance with all safety codes as prescribed under "Limitations".
6. A 1/8-inch NPT plugged tapping, accessible for test gauge connection, must be installed immediately upstream of the gas supply connection to the unit.
7. After the gas connections have been completed, open the main shut-off valve admitting *normal gas pressure* to the mains. *Check all joints for leaks with soap solution or other material suitable for the purpose. NEVER USE A FLAME.*

▲ WARNING**FIRE OR EXPLOSION HAZARD**

Failure to follow the safety warning exactly could result in serious injury, death or property damage.

Never test for gas leaks with an open flame. Use a commercially available soap solution made specifically for the detection of leaks to check all connections. A fire or explosion may result causing property damage, personal injury or loss of life.

▲ CAUTION

The furnace and its individual shut-off valve must be disconnected from the gas supply piping system during any pressure testing at pressures in excess of 1/2 PSIG. Pressures greater than 1/2 PSIG will cause gas valve damage resulting in a hazardous condition. If it is subjected to a pressure greater than 1/2 PSIG, the gas valve must be replaced.

The furnace must be isolated from the gas supply piping system by closing its individual manual shut-off valve during any pressure testing of the gas supply piping system at test pressures equal to or less than 1/2 PSIG.

▲ WARNING

Threaded joints should be coated with a sealing compound that is resistant to the action of liquefied petroleum gases. **Do not use Teflon tape.**

Check all connections for leaks when piping is completed using a soap solution. **NEVER USE A FLAME.**

▲ WARNING**FIRE OR EXPLOSION HAZARD**

Failure to follow the safety warning exactly could result in serious injury, death or property damage.

Never test for gas leaks with an open flame. Use a commercially available soap solution made specifically for the detection of leaks to check all connections. A fire or explosion may result causing property damage, personal injury or loss of life.

Combustion Air and Flue Exhaust

Venting slots in the heating compartment access panel remove the need for a combustion air hood. The gas heat flue exhaust is routed from the unit through a field installed exhaust hood with screen (See Figure 16 for location of hood within the unit and Figure 17 for Installation of the hood. If necessary, a flue exhaust extension may be installed at the point of installation.



Figure 16: Flue Exhaust Hood Shipping Location



Figure 17: Flue Exhaust Hood Installed

Options/Accessories

Economizer

The Economizer can be a factory installed option or a field installed accessory. If factory installed, refer to the instructions included with the outdoor air hood to complete the assembly. Field installed Economizer accessories include complete instructions for installation.

There are two Economizer options. Each is specific to footprint and unit voltage:

1. Vertical Flow application with barometric relief standard.
2. Horizontal Flow application with barometric relief standard.

Power Exhaust

The Power Exhaust is a field installed accessory. Field installed Power Exhaust accessories include complete instructions for installation.

The Power Exhaust factory installed option is for Down Flow application only.

There are two field installed Power Exhaust accessories:

1. Down Flow application.
2. Horizontal Flow application that requires the purchase of a barometric relief hood.

Table 11: Supply Air Limitations

Model (Size)	Supply Air (CFM)	
	Minimum	Maximum
ZQ04 (3)	900	1500
ZQ05 (4)	1200	2000
ZQ06 (5)	1500	2500

Rain Hood

All of the hood components, including the mist eliminators, the gasketing and the hardware for assembling, are packaged and located between the condenser coil section and the main unit cabinet, if the unit has factory installed options. If field installed accessories are being installed all parts necessary for the installation comes in the accessory.

Blower Phasing

ZQ units are properly phased at the factory. Check for proper blower rotation. If the blower rotates in the wrong direction at start-up, the electrical connection to the unit is misphased. Change the phasing of the **Field Line Connection at the factory or field supplied disconnect** to obtain proper rotation.

CAUTION

When installing equipment in a facility with a 3 phase high-leg delta power supply, care must be taken to ensure that the high-leg conductor is not attached to either of the two legs of the (single phase, direct drive) X13 or ECM motors. Failure to do so can result in the motor acting erratically or not running at all.

Check for the high leg conductor by checking voltage of each phase to ground.

Example: A or L1 phase to ground, voltage reading is 120V. B or L2 phase to ground, voltage reading is 195 to 208V. C or L3 phase to ground, voltage reading is 120V. Therefore B or L2 phase is the high Leg. The high should always be wired to the center or B or L2 tap.

Note: Check all three phase motors and compressors for proper rotation after making a change. If it is necessary to change 3 phase motor rotation, swap A or L1 and C or L3 only.

Blower Rotation

Check for proper supply air blower rotation. If the blower is rotating backwards, the line voltage at the unit point of power connection is misphased (See 'BLOWER PHASING').

Belt Tension

The tension on the belt should be adjusted as shown in Figure 18.

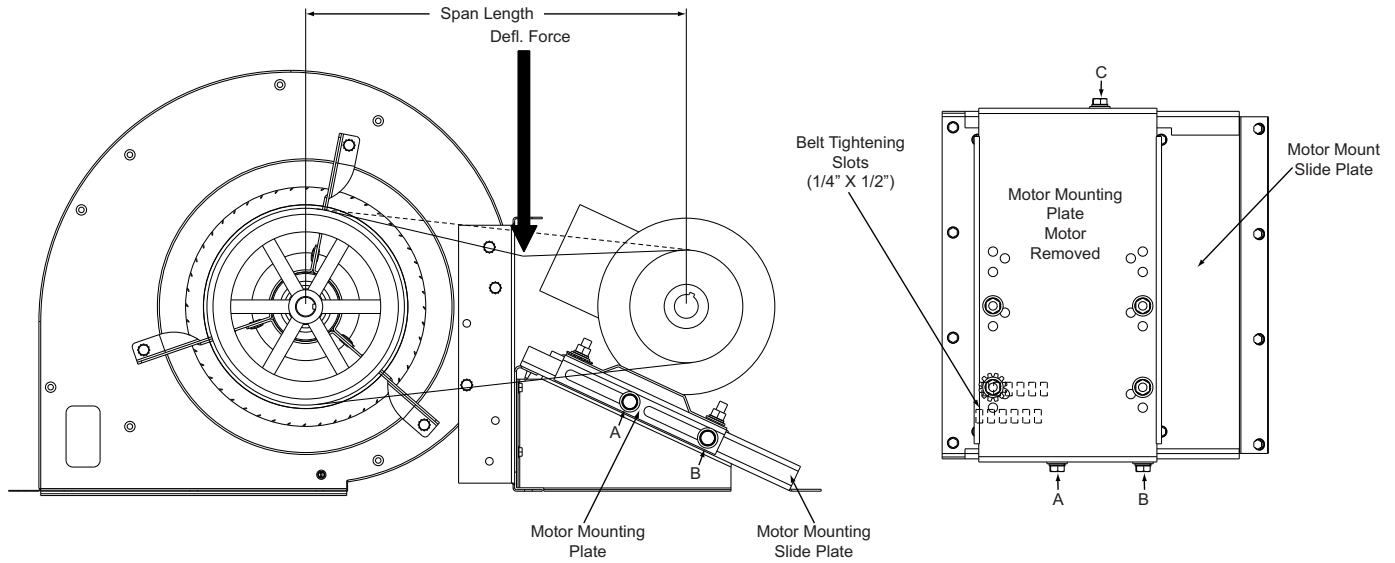

Figure 18: Belt Adjustment

CAUTION

Procedure for adjusting belt tension:

1. Loosen the three nuts (A and B on side and C on back) of motor mount slide plate.
2. Adjust tension by placing a flat heat screwdriver into the belt tightening slots (1/4" X 1/2") in the motor mount slide plate and applying pressure against the motor mounting plate. See Figure 18.
3. Tighten the three loosened nuts (A, B and C).
4. Determine the deflection distance from normal position, use a straight edge from sheave to sheave as reference line. Use belt tension checker to apply a perpendicular force to the belt at the midpoint of the span as shown. Deflection distance of 4mm (5/32") is obtained.
5. After adjustments are completed re-tighten nuts (A, B and C).

Altitude and Temperature Correction for CFM, Static Pressure and Power.

The information below should be used to assist in application of product when being applied at altitudes at or exceeding 1000 feet above sea level.

The air flow rates listed in the standard blower performance tables are based on standard air at sea level. As the altitude or temperature increases, the density of air decreases. In order to use the indoor blower tables for high altitude applications, certain corrections are necessary.

A centrifugal fan is a "constant volume" device. This means that, if the rpm remains constant, the CFM delivered is the same regardless of the density of the air. However, since the air at high altitude is less dense, less static pressure will be generated and less power will be required than a similar application at sea level. Air density correction factors are shown in Table 12 and Figure 19.

Table 12: Altitude/Temperature Correction Factors

Air Temp.	Altitude (Ft.)										
	0	1000	2000	3000	4000	5000	6000	7000	8000	9000	10000
40	1.060	1.022	0.986	0.950	0.916	0.882	0.849	0.818	0.788	0.758	0.729
50	1.039	1.002	0.966	0.931	0.898	0.864	0.832	0.802	0.772	0.743	0.715
60	1.019	0.982	0.948	0.913	0.880	0.848	0.816	0.787	0.757	0.729	0.701
70	1.000	0.964	0.930	0.896	0.864	0.832	0.801	0.772	0.743	0.715	0.688
80	0.982	0.947	0.913	0.880	0.848	0.817	0.787	0.758	0.730	0.702	0.676
90	0.964	0.929	0.897	0.864	0.833	0.802	0.772	0.744	0.716	0.689	0.663
100	0.946	0.912	0.880	0.848	0.817	0.787	0.758	0.730	0.703	0.676	0.651

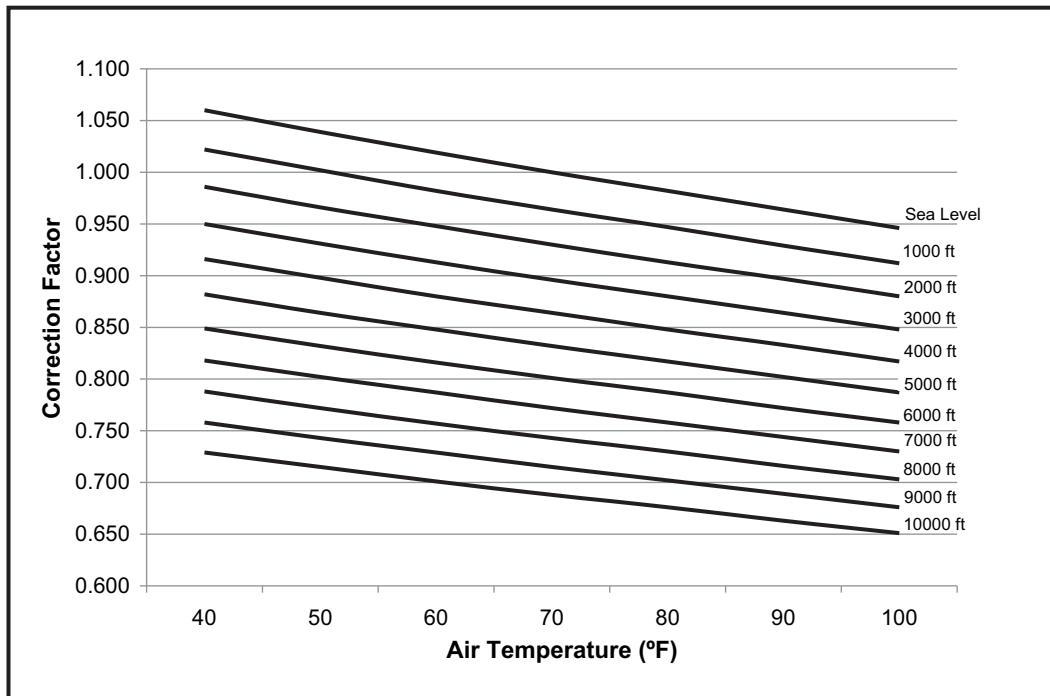
**Figure 19: Altitude/Temperature Correction Factors**

The examples below will assist in determining the airflow performance of the product at altitude.

Example 1: What are the corrected CFM, static pressure, and BHP at an elevation of 5,000 ft. if the blower performance data is 1,400 CFM, 0.6 IWC and 0.67 BHP?

Solution: At an elevation of 5,000 ft. the indoor blower will still deliver 1,400 CFM if the rpm is unchanged. However, Table 13 must be used to determine the static pressure and BHP. Since no temperature data is given, we will assume an air temperature of 70°F. Table 12 shows the correction factor to be 0.832.

$$\text{Corrected static pressure} = 0.6 \times 0.832 = 0.499 \text{ IWC}$$

$$\text{Corrected BHP} = 0.67 \times 0.832 = 0.56$$

Example 2: A system, located at 5,000 feet of elevation, is to deliver 1,400 CFM at a static pressure of 1.5". Use the unit

blower tables to select the blower speed and the BHP requirement.

Solution: As in the example above, no temperature information is given so 70°F is assumed.

The 1.5" static pressure given is at an elevation of 5,000 ft. The first step is to convert this static pressure to equivalent sea level conditions.

$$\text{Sea level static pressure} = 0.6 / .832 = 0.72"$$

Enter the blower table at 1,400 sCFM and static pressure of 0.72". The rpm listed will be the same rpm needed at 5,000 ft.

Suppose that the corresponding BHP listed in the table is 0.7. This value must be corrected for elevation.

$$\text{BHP at 5,000 ft.} = 0.7 \times .832 = 0.58$$

Drive Selection

1. Determine side or bottom supply duct Application.
2. Determine desired airflow.
3. Calculate or measure the amount of external static pressure.
 - Add or deduct any additional static resistance from "Additional Static Resistance Table".
4. Using the operating point determined from steps 1, 2 & 3, locate this point on the appropriate supply air blower performance table. (Linear interpolation may be necessary.)
5. Noting the RPM and BHP from step 4, locate the appropriate motor and, or drive.
6. Review the BHP compared to the motor options available. Select the appropriate motor and, or drive.
7. Review the RPM range for the motor options available. Select the appropriate drive if multiple drives are available for the chosen motor.
8. Determine turns open to obtain the desired operation point.

Example

1. 1600 CFM, bottom supply
2. 1.2 iwg
3. Using the airflow performance table below, the following data point was located: 1359 RPM & 1.11 BHP.
4. Using the RPM selection table below, Model ZQ and Size 05 (4 Tons) is found.
5. 1359 RPM is within the range of the 2.4 HP, High Static drives.
6. Using the 2.4 HP motor and High Static drive, 2-1/2 turns open will achieve 1359 RPM.

Airflow Performance

**Example Supply Air Blower Performance
ZQ05 (4.0 Ton) Bottom Duct**

CFM	AVAILABLE EXTERNAL STATIC PRESSURE - IWG ¹																			
	0.2		0.4		0.6		0.8		1.0		1.2		1.4		1.6		1.8		2.0	
	RPM	BHP	RPM	BHP	RPM	BHP	RPM	BHP	RPM	BHP	RPM	BHP	RPM	BHP	RPM	BHP	RPM	BHP	RPM	BHP
1200	908	0.34	994	0.45	1072	0.55	1145	0.64	1214	0.74	1283	0.83	1352	0.92	1424	1.01	1502	1.11	1586	1.20
1300	921	0.40	1007	0.51	1085	0.61	1158	0.70	1227	0.80	1296	0.89	1365	0.98	1437	1.07	1514	1.17	1599	1.26
1400	938	0.47	1023	0.58	1101	0.68	1174	0.77	1244	0.86	1312	0.96	1382	1.05	1454	1.14	1531	1.23	1616	1.33
1500	959	0.55	1044	0.65	1122	0.75	1195	0.85	1265	0.94	1333	1.03	1403	1.12	1475	1.21	1552	1.31	1637	1.41
1600	985	0.63	1070	0.73	1148	0.83	1221	0.93	1290	1.02	1359	1.11	1428	1.20	1500	1.29	1578	1.39	--	--
1700	1015	0.71	1100	0.82	1179	0.92	1251	1.01	1321	1.11	1389	1.20	1459	1.29	1531	1.38	1608	1.48	--	--
1800	1050	0.81	1136	0.91	1214	1.01	1287	1.11	1356	1.20	1425	1.29	1494	1.39	1566	1.48	1644	1.57	--	--
1900	1091	0.91	1176	1.02	1254	1.12	1327	1.21	1397	1.31	1465	1.40	1534	1.49	1607	1.58	--	--	--	--
2000	1136	1.02	1222	1.13	1300	1.23	1372	1.32	1442	1.42	1510	1.51	1580	1.60	--	--	--	--	--	--

	Medium Static Option with Motor rated at 2.4-hp
	High Static Option with Motor rated at 2.4-hp
	Field supplied AK41 x 3/4" fixed blower pulley with Motor rated at 2.4-hp
--	Exceeds recommended blower speed

1. Blower performance includes gas heat exchangers and 2" filters. See STATIC RESISTANCE table for additional applications.
- Note:** See RPM SELECTION table to determine desired motor sheave setting and to determine the maximum continuous BHP.
 kW = 0.929 x BHP

Example RPM Selection

Model	Size (Tons)	Airflow Option	Phase	Max BHP	Blower Sheave	Motor Sheave	6 Turns Open	5 Turns Open	4 Turns Open	3 Turns Open	2 Turns Open	1 Turns Open	Fully Closed
ZQ	05 (4)	Std.					Direct Drive						
		Med.	1	1.5	AK46	1VL34	N/A	792	875	958	1042	1125	1208
		Med.	3	2.4	AK46	1VL34	N/A	792	875	958	1042	1125	1208
		H. Static	3	2.4	AK46	1VL44	N/A	1167	1250	1333	1417	1500	1593

Example Additional Static Resistance

Model	Size Tons	CFM	Cooling Only ¹	Economizer ^{2,3}	4" Filter ²	Electric Heat kW ²			
						6/6.5	9.2/10.5/11	13.8/14/16	23
ZQ	05 (4.0)	1200	0.07	0.06	---	0.01	0.01	0.02	0.03
		1300	0.10	0.07	---	0.01	0.01	0.03	0.03
		1400	0.12	0.08	---	0.02	0.02	0.03	0.04
		1500	0.14	0.08	---	0.02	0.02	0.04	0.04
		1600	0.16	0.09	---	0.02	0.02	0.04	0.05
		1700	0.18	0.10	---	0.03	0.03	0.05	0.05
		1800	0.22	0.11	---	0.03	0.03	0.05	0.06
		1900	0.25	0.12	---	0.04	0.04	0.06	0.07
		2000	0.28	0.13	---	0.04	0.04	0.07	0.08

Table 13: ZQ04-06 Side Duct Application (Belt Drive)

ZQ04 (3.0 Ton) Side Duct

CFM	AVAILABLE EXTERNAL STATIC PRESSURE - IWG ¹																			
	0.2		0.4		0.6		0.8		1.0		1.2		1.4		1.6		1.8		2.0	
	RPM	BHP	RPM	BHP	RPM	BHP	RPM	BHP	RPM	BHP	RPM	BHP	RPM	BHP	RPM	BHP	RPM	BHP	RPM	BHP
900	n/a	n/a	877	0.25	965	0.34	1050	0.44	1133	0.54	1213	0.64	1292	0.74	1371	0.83	1450	0.92	1531	1.01
1000	795	0.21	887	0.29	976	0.38	1061	0.48	1143	0.58	1224	0.68	1303	0.78	1382	0.87	1461	0.96	1541	1.05
1100	806	0.25	899	0.34	988	0.43	1073	0.53	1155	0.63	1236	0.73	1315	0.83	1394	0.92	1473	1.01	1553	1.09
1200	820	0.31	913	0.39	1002	0.48	1087	0.58	1169	0.68	1249	0.78	1329	0.88	1407	0.97	1487	1.06	1567	1.15
1300	836	0.37	929	0.45	1018	0.54	1103	0.64	1185	0.74	1265	0.84	1345	0.94	1423	1.03	1503	1.12	1583	1.21
1400	855	0.43	948	0.52	1036	0.61	1121	0.70	1204	0.80	1284	0.90	1363	1.00	1442	1.10	1521	1.19	--	--
1500	876	0.50	969	0.58	1058	0.68	1143	0.77	1225	0.87	1305	0.97	1385	1.07	1464	1.17	1543	1.26	--	--

Medium Static Option with Motor rated at 2.4-hp
 High Static Option with Motor rated at 2.4-hp
 -- Exceeds recommended Blower speed

1. Blower performance includes gas heat exchangers and 2" filters. See STATIC RESISTANCE table for additional applications.
Note: See RPM SELECTION table to determine desired motor sheave setting and to determine the maximum continuous BHP.
 kW = 0.929 x BHP

ZQ05 (4.0 Ton) Side Duct

CFM	AVAILABLE EXTERNAL STATIC PRESSURE - IWG ¹																			
	0.2		0.4		0.6		0.8		1.0		1.2		1.4		1.6		1.8		2.0	
	RPM	BHP	RPM	BHP	RPM	BHP	RPM	BHP	RPM	BHP	RPM	BHP	RPM	BHP	RPM	BHP	RPM	BHP	RPM	BHP
1200	893	0.37	976	0.46	1054	0.56	1128	0.66	1199	0.75	1268	0.85	1336	0.94	1404	1.03	1474	1.12	1545	1.20
1300	910	0.43	993	0.52	1071	0.62	1144	0.72	1216	0.81	1285	0.91	1353	1.00	1421	1.09	1491	1.18	1562	1.26
1400	931	0.49	1014	0.59	1092	0.69	1166	0.78	1237	0.88	1306	0.97	1374	1.06	1442	1.15	1512	1.24	1583	1.33
1500	956	0.56	1039	0.66	1117	0.76	1191	0.85	1262	0.95	1331	1.04	1399	1.14	1467	1.23	1537	1.31	1608	1.40
1600	985	0.64	1067	0.74	1145	0.83	1219	0.93	1290	1.03	1359	1.12	1428	1.21	1496	1.30	1565	1.39	1637	1.47
1700	1016	0.73	1099	0.82	1177	0.92	1251	1.02	1322	1.11	1391	1.21	1459	1.30	1528	1.39	1597	1.48	--	--
1800	1051	0.82	1134	0.92	1212	1.02	1286	1.11	1357	1.21	1426	1.30	1494	1.40	1562	1.49	1632	1.57	--	--
1900	1088	0.93	1171	1.02	1249	1.12	1323	1.22	1394	1.31	1463	1.41	1532	1.50	1600	1.59	--	--	--	--
2000	1128	1.04	1211	1.14	1289	1.23	1363	1.33	1434	1.43	1503	1.52	1571	1.61	1640	1.70	--	--	--	--

Medium Static Option with Motor rated at 2.4-hp
 High Static Option with Motor rated at 2.4-hp
 Field supplied AK41 x 3/4" fixed blower pulley with Motor rated at 2.4-hp
 -- Exceeds recommended blower speed

1. Blower performance includes gas heat exchangers and 2" filters. See STATIC RESISTANCE table for additional applications.
Note: See RPM SELECTION table to determine desired motor sheave setting and to determine the maximum continuous BHP.
 kW = 0.929 x BHP

ZQ06 (5.0 Ton) Side Duct

CFM	AVAILABLE EXTERNAL STATIC PRESSURE - IWG ¹																			
	0.2		0.4		0.6		0.8		1.0		1.2		1.4		1.6		1.8		2.0	
	RPM	BHP	RPM	BHP	RPM	BHP	RPM	BHP	RPM	BHP	RPM	BHP	RPM	BHP	RPM	BHP	RPM	BHP	RPM	BHP
1500	806	0.35	885	0.47	961	0.60	1034	0.73	1104	0.86	1170	1.00	1233	1.13	1292	1.26	1346	1.39	1396	1.52
1600	825	0.44	904	0.56	980	0.68	1053	0.81	1123	0.95	1189	1.08	1252	1.22	1311	1.35	1365	1.48	1415	1.61
1700	846	0.52	925	0.64	1001	0.76	1074	0.89	1144	1.03	1210	1.16	1273	1.30	1332	1.43	1386	1.56	1436	1.69
1800	869	0.60	947	0.72	1023	0.84	1096	0.97	1166	1.11	1233	1.24	1295	1.38	1354	1.51	1409	1.64	1459	1.77
1900	892	0.68	971	0.80	1047	0.93	1120	1.06	1190	1.19	1256	1.32	1319	1.46	1378	1.59	1432	1.72	1482	1.85
2000	916	0.77	995	0.89	1071	1.01	1144	1.14	1214	1.28	1280	1.41	1343	1.55	1402	1.68	1456	1.81	1506	1.94
2100	941	0.86	1019	0.98	1095	1.11	1168	1.24	1238	1.37	1305	1.50	1367	1.64	1426	1.77	1481	1.90	1531	2.03
2200	966	0.96	1044	1.08	1120	1.21	1193	1.34	1263	1.47	1329	1.61	1392	1.74	1451	1.87	1505	2.01	1555	2.13
2300	990	1.07	1069	1.19	1145	1.32	1218	1.45	1287	1.58	1354	1.72	1417	1.85	1476	1.98	1530	2.11	1580	2.24
2400	1015	1.19	1093	1.31	1169	1.44	1242	1.57	1312	1.70	1379	1.83	1441	1.97	1500	2.10	1555	2.23	--	--
2500	1039	1.32	1118	1.44	1193	1.56	1266	1.69	1336	1.83	1403	1.96	1466	2.10	1524	2.23	1579	2.36	--	--

Medium Static Option with Motor rated at 2.4-hp
 High Static Option with Motor rated at 2.9-hp
 -- Exceeds recommended blower speed

1. Blower performance includes gas heat exchangers and 2" filters. See STATIC RESISTANCE table for additional applications.
Note: See RPM SELECTION table to determine desired motor sheave setting and to determine the maximum continuous BHP.
 kW = 0.929 x BHP

Table 14: ZQ04-06 Side Duct Application (Direct Drive)

ZQ04-06 Side Duct (Cooling)

Unit (Ton)	Motor Speed	Available External Static														
		0.2			0.4			0.6			0.8			1.0		
		CFM	WATTS	RPM	CFM	WATTS	RPM	CFM	WATTS	RPM	CFM	WATTS	RPM	CFM	WATTS	RPM
ZQ04 (3)	1 (LOW)	1147	152	659	988	181	787	901	203	891	800	226	987	682	247	1071
	2 (MED/LOW)	1214	175	683	1094	206	810	965	232	896	898	258	1003	794	276	1084
	3 (MED)	1402	234	735	1324	264	835	1161	302	947	1074	329	1034	986	351	1114
	4 (MED/HI)	1570	310	791	1512	348	884	1429	381	977	1253	420	1079	1130	423	1148
	5 (HI)	1825	448	866	1769	487	946	1705	521	1023	1610	559	1107	1229	472	1159
ZQ05 (4)	1 (LOW)	1412	261	793	1322	290	884	1244	321	966	1109	347	1059	1035	369	1131
	2 (MED/LOW)	1521	313	831	1461	349	920	1382	374	989	1283	400	1072	1166	426	1150
	3 (MED)	1636	376	874	1574	413	959	1487	441	1034	1413	465	1099	1184	446	1164
	4 (MED/HI)	1813	484	937	1747	522	1013	1668	552	1088	1581	565	1141	1212	458	1170
	5 (HI)	2351	920	1111	2129	819	1138	1912	718	1153	1678	622	1164	1378	513	1176
ZQ06 (5)	1 (LOW)	1692	345	727	1583	374	797	1482	403	866	1380	437	939	1262	462	1000
	2 (MED/LOW)	1849	438	779	1755	468	843	1667	495	902	1552	530	971	1439	558	1033
	3 (MED)	1989	532	818	1904	564	877	1828	598	935	1738	628	994	1633	664	1058
	4 (MED/HI)	2159	673	876	2087	713	931	2010	729	985	1933	778	1035	1859	812	1091
	5 (HI)	2349	852	928	2270	887	978	2195	922	1028	2118	947	1075	1973	914	1109

ZQ04-06 Side Duct (Gas Heat)

Unit (Ton)	Motor Speed	Available External Static														
		0.2			0.4			0.6			0.8			1.0		
		CFM	WATTS	RPM	CFM	WATTS	RPM	CFM	WATTS	RPM	CFM	WATTS	RPM	CFM	WATTS	RPM
ZQ04 (3)	1 (LOW)	1094	165	715	956	187	828	851	213	932	752	237	1026	638	253	1100
	2 (MED/LOW)	1180	189	735	1064	216	842	940	242	945	849	263	1029	748	286	1116
	3 (MED)	1353	251	790	1271	280	883	1138	310	979	1036	338	1068	958	362	1144
	4 (MED/HI)	1517	340	863	1450	374	940	1364	398	1021	1232	434	1114	1022	393	1163
	5 (HI)	1763	490	953	1690	520	1020	1619	549	1086	1442	525	1140	1070	413	1168
ZQ05 (4)	1 (LOW)	1356	285	870	1280	308	939	1185	332	1019	1074	364	1113	850	343	1179
	2 (MED/LOW)	1459	349	920	1390	371	985	1306	393	1050	1195	421	1133	862	350	1182
	3 (MED)	1553	412	973	1475	442	1039	1415	462	1092	1289	469	1155	880	357	1182
	4 (MED/HI)	1718	530	1040	1645	562	1102	1534	555	1147	1377	510	1165	961	390	1183
	5 (HI)	1955	737	1146	1780	665	1156	1587	599	1168	1407	529	1175	902	366	1186
ZQ06 (5)	1 (LOW)	1570	372	791	1463	399	855	1358	425	918	1260	456	983	1161	481	1044
	2 (MED/LOW)	1740	468	845	1638	496	903	1543	529	965	1454	553	1015	1360	578	1070
	3 (MED)	1882	569	889	1786	601	947	1687	629	1002	1587	660	1053	1487	680	1105
	4 (MED/HI)	2052	732	955	1967	749	999	1883	778	1049	1788	808	1099	1621	778	1130
	5 (HI)	2227	905	1004	2138	937	1051	2038	947	1091	1869	887	1118	1662	811	1137

Table 15: ZQ04-06 Bottom Duct Application (Belt Drive)

ZQ04 (3.0 Ton) Bottom Duct

CFM	AVAILABLE EXTERNAL STATIC PRESSURE - IWG ¹																			
	0.2		0.4		0.6		0.8		1.0		1.2		1.4		1.6		1.8		2.0	
	RPM	BHP	RPM	BHP	RPM	BHP	RPM	BHP	RPM	BHP	RPM	BHP	RPM	BHP	RPM	BHP	RPM	BHP	RPM	BHP
900	792	0.14	879	0.25	968	0.37	1055	0.49	1141	0.61	1226	0.73	1308	0.84	1388	0.93	1466	1.01	1541	1.06
1000	804	0.18	893	0.29	981	0.41	1069	0.53	1155	0.66	1239	0.77	1322	0.88	1402	0.98	1480	1.05	1554	1.10
1100	819	0.23	909	0.34	997	0.46	1084	0.58	1171	0.71	1255	0.82	1337	0.93	1418	1.03	1495	1.10	1570	1.15
1200	837	0.29	926	0.40	1015	0.52	1102	0.64	1188	0.76	1273	0.88	1355	0.99	1435	1.08	1513	1.16	1588	1.21
1300	857	0.36	946	0.46	1035	0.58	1122	0.70	1208	0.83	1293	0.94	1375	1.05	1455	1.15	1533	1.22	--	--
1400	880	0.43	969	0.53	1058	0.65	1145	0.77	1231	0.90	1315	1.02	1398	1.12	1478	1.22	1556	1.29	--	--
1500	905	0.50	994	0.61	1082	0.73	1170	0.85	1256	0.97	1340	1.09	1423	1.20	1503	1.30	1581	1.37	--	--

Medium Static Option with Motor rated at 2.4-hp
 High Static Option with Motor rated at 2.4-hp
 -- Exceeds recommended Blower speed

1. Blower performance includes gas heat exchangers and 2" filters. See STATIC RESISTANCE table for additional applications.
Note: See RPM SELECTION table to determine desired motor sheave setting and to determine the maximum continuous BHP.
 kW = 0.929 x BHP

ZQ05 (4.0 Ton) Bottom Duct

CFM	AVAILABLE EXTERNAL STATIC PRESSURE - IWG ¹																			
	0.2		0.4		0.6		0.8		1.0		1.2		1.4		1.6		1.8		2.0	
	RPM	BHP	RPM	BHP	RPM	BHP	RPM	BHP	RPM	BHP	RPM	BHP	RPM	BHP	RPM	BHP	RPM	BHP	RPM	BHP
1200	908	0.34	994	0.45	1072	0.55	1145	0.64	1214	0.74	1283	0.83	1352	0.92	1424	1.01	1502	1.11	1586	1.20
1300	921	0.40	1007	0.51	1085	0.61	1158	0.70	1227	0.80	1296	0.89	1365	0.98	1437	1.07	1514	1.17	1599	1.26
1400	938	0.47	1023	0.58	1101	0.68	1174	0.77	1244	0.86	1312	0.96	1382	1.05	1454	1.14	1531	1.23	1616	1.33
1500	959	0.55	1044	0.65	1122	0.75	1195	0.85	1265	0.94	1333	1.03	1403	1.12	1475	1.21	1552	1.31	1637	1.41
1600	985	0.63	1070	0.73	1148	0.83	1221	0.93	1290	1.02	1359	1.11	1428	1.20	1500	1.29	1578	1.39	--	--
1700	1015	0.71	1100	0.82	1179	0.92	1251	1.01	1321	1.11	1389	1.20	1459	1.29	1531	1.38	1608	1.48	--	--
1800	1050	0.81	1136	0.91	1214	1.01	1287	1.11	1356	1.20	1425	1.29	1494	1.39	1566	1.48	1644	1.57	--	--
1900	1091	0.91	1176	1.02	1254	1.12	1327	1.21	1397	1.31	1465	1.40	1534	1.49	1607	1.58	--	--	--	--
2000	1136	1.02	1222	1.13	1300	1.23	1372	1.32	1442	1.42	1510	1.51	1580	1.60	--	--	--	--	--	--

Medium Static Option with Motor rated at 2.4-hp
 High Static Option with Motor rated at 2.4-hp
 Bold Field supplied AK41 x 3/4" fixed blower pulley with Motor rated at 2.4-hp
 -- Exceeds recommended blower speed

1. Blower performance includes gas heat exchangers and 2" filters. See STATIC RESISTANCE table for additional applications.
Note: See RPM SELECTION table to determine desired motor sheave setting and to determine the maximum continuous BHP.
 kW = 0.929 x BHP

ZQ06 (5.0 Ton) Bottom Duct

CFM	AVAILABLE EXTERNAL STATIC PRESSURE - IWG ¹																			
	0.2		0.4		0.6		0.8		1.0		1.2		1.4		1.6		1.8		2.0	
	RPM	BHP	RPM	BHP	RPM	BHP	RPM	BHP	RPM	BHP	RPM	BHP	RPM	BHP	RPM	BHP	RPM	BHP	RPM	BHP
1500	846	0.34	914	0.48	983	0.62	1052	0.75	1120	0.89	1188	1.02	1254	1.16	1318	1.29	1378	1.43	1435	1.56
1600	868	0.41	936	0.55	1004	0.68	1073	0.82	1142	0.95	1210	1.09	1276	1.23	1339	1.36	1400	1.50	1457	1.63
1700	889	0.49	957	0.62	1026	0.76	1095	0.90	1164	1.03	1231	1.17	1297	1.30	1361	1.44	1422	1.57	1479	1.71
1800	911	0.57	979	0.71	1048	0.85	1117	0.98	1186	1.12	1253	1.25	1319	1.39	1383	1.53	1443	1.66	1501	1.79
1900	934	0.67	1002	0.81	1071	0.94	1140	1.08	1208	1.21	1276	1.35	1342	1.48	1405	1.62	1466	1.75	1523	1.89
2000	958	0.77	1026	0.91	1094	1.04	1164	1.18	1232	1.32	1300	1.45	1366	1.59	1429	1.72	1490	1.86	1547	1.99
2100	983	0.88	1051	1.02	1120	1.15	1189	1.29	1258	1.42	1325	1.56	1391	1.69	1455	1.83	1516	1.96	1573	2.10
2200	1010	0.99	1078	1.13	1147	1.26	1216	1.40	1285	1.54	1352	1.67	1418	1.81	1482	1.94	1543	2.08	--	--
2300	1039	1.11	1107	1.25	1176	1.38	1245	1.52	1314	1.65	1381	1.79	1447	1.93	1511	2.06	1572	2.20	--	--
2400	1070	1.23	1138	1.37	1207	1.50	1276	1.64	1345	1.78	1412	1.91	1478	2.05	1542	2.18	--	--	--	--
2500	1103	1.36	1171	1.49	1240	1.63	1309	1.77	1378	1.90	1445	2.04	1511	2.17	1575	2.31	--	--	--	--

Medium Static Option with Motor rated at 2.4-hp
 High Static Option with Motor rated at 2.9-hp
 -- Exceeds recommended blower speed

1. Blower performance includes gas heat exchangers and 2" filters. See STATIC RESISTANCE table for additional applications.
Note: See RPM SELECTION table to determine desired motor sheave setting and to determine the maximum continuous BHP.
 kW = 0.929 x BHP

Table 16: ZQ04-06 Bottom Duct Application (Direct Drive)

ZQ04-06 Bottom Duct (Cooling)

Unit (Ton)	Motor Speed	Available External Static														
		0.2			0.4			0.6			0.8			1.0		
		CFM	WATTS	RPM	CFM	WATTS	RPM	CFM	WATTS	RPM	CFM	WATTS	RPM	CFM	WATTS	RPM
ZQ04 (3)	1 (LOW)	1086	165	721	929	192	837	861	211	927	769	235	1023	636	253	1108
	2 (MED/LOW)	1171	192	745	1035	221	856	946	241	944	868	267	1037	771	290	1119
	3 (MED)	1328	257	806	1255	280	890	1106	316	993	1038	336	1068	944	354	1148
	4 (MED/HI)	1509	340	867	1449	376	953	1309	407	1046	1210	436	1121	1002	387	1162
	5 (HI)	1740	490	959	1683	522	1033	1618	555	1101	1315	500	1149	1037	404	1168
ZQ05 (4)	1 (LOW)	1330	284	863	1261	302	929	1172	329	1006	1053	353	1088	970	376	1162
	2 (MED/LOW)	1458	349	917	1385	372	981	1307	395	1047	1174	421	1129	1023	398	1170
	3 (MED)	1553	414	965	1477	440	1033	1427	461	1086	1334	480	1148	1017	400	1175
	4 (MED/HI)	1714	532	1041	1638	563	1107	1555	563	1143	1374	503	1161	1033	406	1176
	5 (HI)	1935	740	1150	1768	667	1160	1610	610	1167	1421	536	1175	1061	421	1183
ZQ06 (5)	1 (LOW)	1600	355	759	1518	390	831	1437	418	897	1324	445	961	1224	469	1020
	2 (MED/LOW)	1760	449	811	1676	486	879	1587	514	938	1497	547	999	1414	574	1057
	3 (MED)	1898	554	859	1809	587	921	1735	619	977	1641	647	1035	1549	675	1088
	4 (MED/HI)	2072	708	923	1991	741	977	1917	775	1029	1836	802	1079	1702	794	1122
	5 (HI)	2228	884	980	2151	919	1031	2072	944	1077	1945	914	1109	1731	822	1131

ZQ04-06 Bottom Duct (Gas Heat)

Unit (Ton)	Motor Speed	Available External Static														
		0.2			0.4			0.6			0.8			1.0		
		CFM	WATTS	RPM	CFM	WATTS	RPM	CFM	WATTS	RPM	CFM	WATTS	RPM	CFM	WATTS	RPM
ZQ04 (3)	1 (LOW)	1047	167	733	903	195	854	808	220	956	693	238	1042	567	254	1115
	2 (MED/LOW)	1122	197	769	995	225	876	899	252	979	804	276	1065	682	294	1143
	3 (MED)	1275	262	829	1197	291	916	1058	324	1025	963	350	1108	792	334	1165
	4 (MED/HI)	1461	353	895	1391	381	972	1279	415	1064	1123	432	1146	854	355	1169
	5 (HI)	1674	506	993	1620	538	1061	1533	555	1123	1179	463	1161	885	369	1176
ZQ05 (4)	1 (LOW)	1301	300	911	1211	324	986	1112	349	1062	1007	371	1144	738	318	1184
	2 (MED/LOW)	1408	366	970	1331	390	1041	1232	416	1117	1061	401	1169	693	306	1184
	3 (MED)	1496	436	1019	1425	459	1079	1331	482	1146	1083	415	1171	717	316	1184
	4 (MED/HI)	1641	553	1091	1566	566	1138	1392	520	1160	1104	429	1176	738	321	1185
	5 (HI)	1779	680	1160	1630	621	1167	1428	547	1174	1144	447	1184	761	332	1191
ZQ06 (5)	1 (LOW)	1572	373	802	1466	402	868	1378	434	935	1264	461	999	1183	484	1055
	2 (MED/LOW)	1718	475	859	1632	508	920	1531	535	980	1438	562	1036	1344	592	1094
	3 (MED)	1868	578	908	1777	606	961	1687	639	1019	1591	666	1074	1474	678	1122
	4 (MED/HI)	2019	740	976	1944	770	1023	1859	797	1070	1743	796	1114	1528	728	1139
	5 (HI)	2182	927	1035	2089	949	1080	1961	918	1109	1808	854	1128	1552	737	1144

Table 17: RPM Selection

Model	Size (Tons)	Airflow Option	Motor phase	Max BHP	Blower Sheave	Motor Sheave	6 Turns Open	5 Turns Open	4 Turns Open	3 Turns Open	2 Turns Open	1 Turns Open	Fully Closed
ZQ	04 (3)	Std.				Direct Drive							
		Med.	1	1.5	AK46	1VL34	N/A	792	875	958	1042	1125	1208
		Med.	3	2.4	AK46	1VL34	N/A	792	875	958	1042	1125	1208
		H. Static	3	2.4	AK46	1VL44	N/A	1167	1250	1333	1417	1500	1593
ZQ	05 (4)	Std.				Direct Drive							
		Med.	1	1.5	AK46	1VL34	N/A	792	875	958	1042	1125	1208
		Med.	3	2.4	AK46	1VL34	N/A	792	875	958	1042	1125	1208
		H. Static	3	2.4	AK46	1VL44	N/A	1167	1250	1333	1417	1500	1593
ZQ	06 (5)	Std.				Direct Drive							
		Med.	1	1.5	AK46	1VL34	N/A	792	875	958	1042	1125	1208
		Med.	3	2.4	AK46	1VL34	N/A	792	875	958	1042	1125	1208
		H. Static	3	2.9	AK46	1VL44	N/A	1167	1250	1333	1417	1500	1593

Table 18: Indoor Blower Specifications

Model	Size (Tons)	Airflow Option	Motor					Motor Sheave			Blower Sheave			Belt		
			phase	HP	RPM	Eff.	SF	Frame	Datum Dia. (in.)	Bore (in.)	Model	Datum Dia. (in.)	Bore (in.)		Model	
ZQ	04 (3)	Std.	Direct Drive													
		Med.	1	1.5	1725	0.79	1.15	56HZ	1.9 - 2.9	5/8	1VL34	4.2	3/4		AK46	A39
		Med.	3	2.4	1725	0.80	1.15	56Y	1.9 - 2.9	5/8	1VL34	4.2	3/4		AK46	A39
		H. Static	3	2.4	1725	0.80	1.15	56Y	2.8 - 3.8	5/8	1VL44	4.2	3/4		AK46	A40
ZQ	05 (4)	Std.	Direct Drive													
		Med.	1	1.5	1725	0.79	1.15	56HZ	1.9 - 2.9	5/8	1VL34	4.2	3/4		AK46	A39
		Med.	3	2.4	1725	0.80	1.15	56Y	1.9 - 2.9	5/8	1VL34	4.2	3/4		AK46	A39
		H. Static	3	2.4	1725	0.80	1.15	56Y	2.8 - 3.8	5/8	1VL44	4.2	3/4		AK46	A40
ZQ	06 (5)	Std.	Direct Drive													
		Med.	1	1.5	1725	0.79	1.15	56HZ	1.9 - 2.9	5/8	1VL34	4.2	3/4		AK46	A37
		Med.	3	2.4	1725	0.80	1.15	56Y	1.9 - 2.9	5/8	1VL34	4.2	3/4		AK46	A37
		H. Static	3	2.9	1725	0.81	1.15	56Y	2.8 - 3.8	7/8	1VL44	4.2	3/4		AK46	A39

Supply Air Drive Adjustment



Before making any blower speed changes review the installation for any installation errors, leaks or undesirable systems effects that can result in loss of airflow.

Even small changes in blower speed can result in substantial changes in static pressure and BHP. BHP and AMP draw of the blower motor will increase by the cube of the blower speed. Static pressure will increase by the square of the blower speed. Only qualified personnel should make blower speed changes, strictly adhering to the fan laws.

At unit start-up, the measured CFM may be higher or lower than the required CFM. To achieve the required CFM, the speed of the drive may have adjusted by changing the datum diameter (DD) of the variable pitch motor sheave as described below:

$$\left(\frac{\text{Required CFM}}{\text{Measured CFM}} \right) \cdot \text{Existing DD} = \text{New DD}$$

Use the following tables and the DD calculated per the above equation to adjust the motor variable pitch sheave.

EXAMPLE NEW DATUM DIAMETER

A 4 ton unit was selected to deliver 1,600 CFM with a 1VL34 motor sheave, but the unit is delivering 1,350 CFM. The variable pitch motor sheave is set at 4 turns open.

Use the equation to determine the required DD for the new motor sheave,

$$\left(\frac{1,600 \text{ CFM}}{1,350 \text{ CFM}} \right) \cdot 2.1 \text{ in.} = 2.48 \text{ in.}$$

Use Table 19 to locate the DD nearest to 2.48 in. Close the sheave to 2 turn open.

EXAMPLE NEW BHP

$$= (\text{Speed increase})^3 \cdot \text{Original BHP} = \text{New BHP}$$

$$= (\text{Speed increase})^3 \cdot \text{BHP at 1,350 CFM}$$

EXAMPLE NEW MOTOR AMPS

$$= (\text{Speed increase})^3 \cdot \text{Original Amps} = \text{New Amps}$$

$$= (\text{Speed increase})^3 \cdot \text{Amps at 1,350 CFM}$$

Table 19: Motor Sheave Datum Diameters

1VL34		1VL44	
Turns Open	Datum Diameter	Turns Open	Datum Diameter
0	2.9	0	3.8
1/2	2.8	1/2	3.7
1	2.7	1	3.6
1-1/2	2.6	1-1/2	3.5
2	2.5	2	3.4
2-1/2	2.4	2-1/2	3.3
3	2.3	3	3.2
3-1/2	2.2	3-1/2	3.1
4	2.1	4	3.0
4-1/2	2.0	4-1/2	2.9
5	1.9	5	2.8
5-1/2	-	5-1/2	-
6	-	6	-



Belt drive blower systems **MUST** be adjusted to the specific static and CFM requirements for the application. The Belt drive blowers are **NOT** set at the factory for any specific static or CFM. Adjustments of the blower speed and belt tension are **REQUIRED**. Verify proper sheave alignment; tighten blower pulley and motor sheave set screws after these adjustments. Re-checking set screws and belt tension after 10-12 hrs. run time is recommended.

Table 20: Additional Static Resistance - ZQ04-06

Model	Size Tons	CFM	Cooling Only ¹	Economizer ^{2 3}	4" Filter ²	Electric Heat kW ²			
						6/6.5	9.2/10.5/11	13.8/14/16	23
ZQ	04 (3.0), 05 (4.0)	900	0.04	0.15	---	0.00	0.00	0.01	0.01
		1000	0.05	0.18	---	0.00	0.00	0.02	0.02
		1100	0.06	0.21	---	0.01	0.01	0.02	0.03
		1200	0.07	0.24	---	0.01	0.01	0.02	0.03
		1300	0.10	0.28	---	0.01	0.01	0.03	0.03
		1400	0.12	0.33	---	0.02	0.02	0.03	0.04
		1500	0.14	0.44	---	0.02	0.02	0.04	0.04
		1600	0.16	0.52	---	0.02	0.02	0.04	0.05
		1700	0.18	0.59	---	0.03	0.03	0.05	0.05
		1800	0.22	0.66	---	0.03	0.03	0.05	0.06
		1900	0.25	0.74	---	0.04	0.04	0.06	0.07
		2000	0.28	0.81	---	0.04	0.04	0.07	0.08
		2100	0.33	0.88	---	0.05	0.05	0.07	0.08
		2200	0.36	0.95	---	0.06	0.06	0.08	0.09
		2300	0.41	1.03	---	0.06	0.06	0.09	0.10
		2400	0.45	1.10	---	0.07	0.07	0.10	0.11
	2500	0.50	1.17	---	0.08	0.08	0.11	0.12	
	06 (5.0)	1800	0.23	0.66	---	0.03	0.03	0.05	0.06
		2000	0.28	0.81	---	0.04	0.04	0.07	0.08
		2200	0.32	0.95	---	0.06	0.06	0.08	0.09
2400		0.37	1.10	---	0.07	0.07	0.10	0.11	

1. Add these values to the available static resistance in the respective Blower Performance Tables.
2. Deduct these values from the available external static pressure shown in the respective Blower Performance Tables.
3. The pressure drop through the economizer is greater for 100% outdoor air than for 100% return air. If the resistance of the return air duct is less than 0.25 IWG, the unit will deliver less CFM during full economizer operation.



Figure 20: Unit Control Board

Table 21: Smart Equipment™ UCB Details

Description		Function & Comments
Terminal Directional orientation: viewed with silkscreen labels upright		
Limit, 24 VAC power and shutdown connections from unit wiring harness at left on upper edge of UCB		
LIMIT	Monitored 24 VAC input through heat section limit switch(es)	If voltage is absent, indicating the heat section is over-temperature, the UCB will bring on the indoor blower
C	24 VAC, 75 VA transformer Common referenced to cabinet ground	Connects through circuit traces to thermostat connection strip C and indoor blower VFD pin C
24V	24 VAC, 75 VA transformer hot	Powers the UCB microprocessor, connects through circuit trace to the SD 24 terminal
SD 24	24 VAC hot out for factory accessory smoke detector, condensate overflow and/or user shutdown relay switching in series	Connects through circuit trace to thermostat connection strip SD-24. A wiring harness jumper plug connecting SD 24 to SD R is in place if factory accessories for unit shutdown are not used - this jumper plug must be removed if the switching of field-added external accessories for unit shutdown are wired between thermostat connection strip SD-24 and R
SD R	24 VAC hot return from factory accessory smoke detector, condensate overflow and user shutdown relay switching in series	Connects through circuit trace to the R terminal on the upper left of the board
R	24 VAC hot for switched inputs to the UCB	Connects through circuit trace to the thermostat connection strip R terminal, right FAN OVR pin, right HPS1 pin, right HPS2 pin, lower DFS pin and lower APS pin

Table 21: Smart Equipment™ UCB Details (Continued)

Description		Function & Comments
Terminal Thermostat connection strip on left edge of UCB		
W1	1st stage heating request, 24 VAC input switched from R	Not effective for cooling-only units
W2	2nd stage heating request, 24 VAC input switched from R	Not effective for cooling-only units or units with single-stage heat sections
Y1	1st stage cooling request, 24 VAC input switched from R	
Y2	2nd stage cooling request, 24 VAC input switched from R	Visible in the display menu when the #ClgStgs parameter is set for 2 or more, also effective for economizer free cooling supply air temperature reset when the #ClgStgs parameter is set for 1 or more
G	Continuous indoor blower request, 24 VAC input switched from R	
OCC	Occupancy request, 24 VAC input switched from R	Must have the OccMode parameter set for External to be effective
X	Hard lockout indicator, 24 volt output to a light thermostat LED	
R	24 VAC hot for thermostat switching and power	If field-added external accessories for unit shutdown are used, 24 VAC hot return from smoke detector, condensate overflow and/or user shutdown relay switching in series
SD-24	If field-added external accessories for unit shutdown are used, 24 VAC hot out for smoke detector, condensate over-flow and/or user shutdown relay switching in series	Unit wiring harness jumper plug for factory shutdown accessories must be removed if the switching of field-added external accessories for unit shutdown are wired between thermo- stat connection strip SD-24 and R
C	24 VAC common for thermostat power	
LEDs on left edge of UCB		
POWER	Green UCB power indicator	Lit indicates 24 VAC is present at C and 24V terminals
FAULT	Red hard lockout, networking error and firmware error indicator	1/2 second on/off flashing indicates one or more alarm is currently active, 1/10th second on/off flashing indicates a networking error (polarity, addressing, etc.) or a firmware error (likely correctable with re-loading from USB flash drive)
SA BUS	Green UCB SA bus communication transmission indicator	Lit/flickering indicates UCB SA bus communication is currently active, off indicates the UCB is awaiting SA bus communication
Terminal Space temperature sensor connections at center on upper edge of UCB		
ST	Space Temperature sensor input from 10KΩ @ 77°F, Type III negative temperature coefficient thermistor	Positive of VDC circuit (3.625 VDC reading to COM with open circuit), effective if "Thermo- stat-only Control" parameter is set OFF, space sensor override momentary shorts ST to COM to initiate/terminate temporary occupancy
COM	Common for ST and SSO inputs	Negative of VDC circuit for ST and SSO inputs
SSO	Space Sensor Offset input from 0 to 20KΩ potentiometer	Positive of VDC circuit (3.625 VDC reading to COM with open circuit), 10KΩ/2.5 VDC is 0°F offset, 0Ω/0 VDC is maximum above offset and 20KΩ/3.4 VDC is maximum below offset from active space temperature setpoint
Pin Temperature sensor connections at right on upper edge of UCB		
SAT+	Supply Air Temperature sensor input from 10KΩ @ 77°F, Type III negative temperature coefficient thermistor	Input required for operation; 3.625 VDC reading SAT+ to SAT- with open circuit. Used in heat/cool staging cutouts, free cooling operation, demand ventilation operation, comfort ventilation operation, economizer loading operation, VAV cooling operation, hydronic heat operation.

Table 21: Smart Equipment™ UCB Details (Continued)

Description		Function & Comments
RAT+	Return Air Temperature sensor input from 10KΩ @ 77°F, Type III negative temperature coefficient thermistor	Input required for operation; 3.625 VDC reading RAT+ to RAT- with open circuit. Used in return air enthalpy calculation. Substitutes for space temperature if no other space temperature input is present.
OAT+	Outside Air Temperature sensor input from 10KΩ @ 77°F, Type III negative temperature coefficient thermistor	Input required for operation but may be a communicated value; 3.625 VDC reading OAT+ to OAT- with open circuit. Used in heat/cool cutouts, low ambient cooling determination, dry bulb free cooling changeover, outside air enthalpy calculation, economizer loading operation, heat pump demand defrost calculation.
CC1+	#1 refrigerant circuit Condenser Coil temperature sensor input from 10KΩ @ 77°F, Type III negative temperature coefficient thermistor	Input required for heat pump units, not required for A/C units; 3.625 VDC reading CC1+ to CC1- with open circuit. Used in heat pump demand defrost calculation.
EC1+	#1 refrigerant circuit Evaporator Coil temperature sensor input from 10KΩ @ 77°F, Type III negative temperature coefficient thermistor	Input required for operation; 3.625 VDC reading EC1+ to EC1- with open circuit. Used in suction line temperature safety.
CC2+	#2 refrigerant circuit Condenser Coil temperature sensor input from 10KΩ @ 77°F, Type III negative temperature coefficient thermistor	Input required for 2-compressor heat pump units, not required for 2-compressor A/C units, not active for 1-compressor units; 3.625 VDC reading CC2+ to CC2- with open circuit. Used in heat pump demand defrost calculation.
EC2+	#2 refrigerant circuit Evaporator Coil temperature sensor input from 10KΩ @ 77°F, Type III negative temperature coefficient thermistor	Input required for operation of 2-compressor units, not active for 1-compressor units; 3.625 VDC reading EC2+ to EC2- with open circuit. Used in suction line temperature safety.
Pinned connections on right edge of UCB		
RAH+	Return Air Humidity input from 0-10 VDC @ 0-100% RH sensor	Input required for reheat units, optional in all other units, may be a communicated value. Used in return air enthalpy calculation, temperature/humidity setpoint reset, reheat operation.
DCT PRS+	Supply Duct Pressure input from 0-10 VDC @ 0-5" w.c. sensor	Input required for variable air volume units. Used in VAV indoor blower operation.
DFS (upper pin)	24 VAC hot return from Dirty Filter Switch	Optional input; switch closure for greater than 15 seconds during indoor blower operation initiates a notification alarm
DFS (lower pin)	24 VAC hot out for Dirty Filter Switch	Connects through circuit trace to the R terminal
APS (upper pin)	24 VAC hot return from Air Proving Switch	When this optional input is enabled: the air proving switch must close within 30 seconds of initiation of indoor blower operation and not open for greater than 10 seconds during indoor blower operation to allow heat/cool operation and prevent an "APS open" alarm; the air proving switch must open within 30 seconds of termination of indoor blower operation to prevent an "APS stuck closed" notification alarm
APS (lower pin)	24 VAC hot out for Air Proving Switch	Connects through circuit trace to the R terminal
C	Common for the VFD output	Negative of the VDC circuit for the VFD output
VFD	2-10 VDC (0-100%) output for the indoor blower Variable Frequency Drive	Output is active with indoor blower operation. For CV units: this output provides stepped IntelliSpeed control of the indoor blower VFD based on fan-only, cooling stage and heating stage outputs. For VAV units: this output provides control of the indoor blower VFD based on supply duct static pressure input and setpoint.
VFDFLT	24 VAC hot input from the normally open VFD alarm contact	The VFD alarm contact switches from R within the unit wiring harness. 24 VAC input results in unit shutdown and a "VFD fault" alarm

Table 21: Smart Equipment™ UCB Details (Continued)

Description		Function & Comments
Terminal at lower right corner of UCB		
24V FOR OUTPUTS	24 VAC hot for H1, H2, CN-FAN, AUX HGR, FAN C1 and C2 output relay contact switching	Output relay circuitry is isolated from other UCB components and the 24 VAC hot source may be from a second transformer in the unit
Pin Heat section connections at right on lower edge of UCB		
H1	24 VAC hot output for heat section stage 1	Not effective for cooling-only units. Output if demand is present and permissions allow one stage or two stages of heat section operation
H2	24 VAC hot output for heat section stage 2	Not effective for cooling-only units or units with single-stage heat sections. Output if demand is present and permissions allow two stages of heat section operation
MV	24 VAC hot input confirming heat section operation	Sourced from gas valve in gas heat units or first stage heat contactor in electric heat units. Input within 5 minutes from initiation of H1 output initiates the "Heat On Fan Delay" timer, loss of input following the termination of H1 output initiates the "Heat On Fan Delay" timer, no input within 5 minutes from initiation of H1 output initiates an "Ignition Failure" alarm, input for longer than 5 minutes without H1 output initiates a "Gas Valve Mis-wire" alarm
Pin Cooling and fan output connections at right on lower edge of UCB		
CN-FAN	24 VAC hot output for the condenser fan contactor coil	Output with either C1 or C2 output; interrupted during defrost cycle for heat pump units
AUX HGR	24 VAC hot output for hot gas reheat components	Effective only for reheat units, output with reheat operation
FAN	24 VAC hot output for indoor blower contactor coil/indoor blower VFD enable relay coil	Output with heat/cool operation, G input or schedule demand
C1	24 VAC hot output for compressor 1	If demand is present and permissions allow compressor 1 operation; output with compressor cooling, comfort ventilation cooling, reheat or heat pump heating demands
C2	24 VAC hot output for compressor 2	Not effective for one stage compressor UCBs. If demand is present and permissions allow compressor 2 operation; output with compressor cooling, comfort ventilation cooling or heat pump heating demands
Pin Refrigerant circuit safety switch and indoor blower overload connections at center on lower edge of UCB		
HPS1 (right pin)	24 VAC hot out for refrigerant circuit 1 High Pressure Switch	Connects through circuit trace to the R terminal
HPS1 (left pin)	24 VAC hot return from refrigerant circuit 1 High Pressure Switch	Input is only considered if C1 output is needed; input must be present to allow C1 output. Three HPS1 trips in a two hour period cause a "High Pressure Switch 1 Lockout" and C1 output is then prevented until alarm reset. Connects through circuit trace to the right LPS1 pin.
LPS1 (right pin)	24 VAC hot out for refrigerant circuit 1 Low Pressure Switch	Connects through circuit trace to the left HSP1 pin
LPS1 (left pin)	24 VAC hot return from refrigerant circuit 1 Low Pressure Switch	Input is only considered after 30 seconds of C1 output; afterwards, input must be present to allow C1 output. Three LPS1 trips in a one hour period cause a "Low Pressure Switch 1 Lockout" and C1 output is then prevented until alarm reset.
HPS2 (right pin)	24 VAC hot out for refrigerant circuit 2 High Pressure Switch	Not effective for one stage compressor UCBs. Connects through circuit trace to the R terminal

Table 21: Smart Equipment™ UCB Details (Continued)

Description		Function & Comments
HPS2 (left pin)	24 VAC hot return from refrigerant circuit 2 High Pressure Switch	Not effective for one stage compressor UCBs. Input is only considered if C2 output is needed; input must be present to allow C1 output. Three HPS2 trips in a two hour period cause a "High Pressure Switch 1 Lockout" and C2 output is then prevented until alarm reset. Connects through circuit trace to the right LPS2 pin.
LPS2 (right pin)	24 VAC hot out for refrigerant circuit 2 Low Pressure Switch	Not effective for one stage compressor UCBs. Connects through circuit trace to the left HSP2 pin
LPS2 (left pin)	24 VAC hot return from refrigerant circuit 2 Low Pressure Switch	Not effective for one stage compressor UCBs. Input is only considered after 30 seconds of C2 output; afterwards, input must be present to allow C2 output. Three LPS2 trips in a one hour period cause a "Low Pressure Switch 2 Lockout" and C2 output is then prevented until alarm reset.
FAN OVR (right pin)	24 VAC hot out for indoor blower FAN Overload relay contact/motor protector switch	Connects through circuit trace to the R terminal
FAN OVR (left pin)	24 VAC hot return from indoor blower FAN Overload relay contact/motor protector switch	Input is only considered if FAN output is needed; input must be present to allow FAN output and unit operation. One FAN OVR trip lasting longer than 5 minutes or three FAN OVR trips in a two hour period cause a "Fan Overload Lockout" and unit operation is then prevented until alarm reset.
Terminal SA BUS¹ connections on at left on lower edge and center of UCB		
PWR	Power for SA ("Sensor-Actuator") BUS devices	Also incorporated in the J8 6-pin phone jack connector at the left-center of the board. Positive of the 15 VDC (reading to C) circuit for powering an optional netstat and/or Multi Touch gateway
C	Common for SA BUS power and communication circuits	Also incorporated in the J8 6-pin phone jack connector at the left-center of the board. Negative of the SA BUS circuits
-	Communication for SA BUS devices	Also incorporated in the J8 6-pin phone jack connector at the left-center of the board. Positive of the VDC (typically, a fluctuating 1.5 to 3.5 volts reading to C; at least 0.25 volts lower than +) SA BUS communication circuit to optional economizer board, 4-stage board, fault detection & diagnostics board, netstat and/or Multi Touch gateway
+	Communication for SA BUS devices	Also incorporated in the J8 6-pin phone jack connector at the left-center of the board. Positive of the VDC (typically, a fluctuating 1.5 to 3.5 volts reading to C; at least 0.25 volts higher than -) SA BUS communication circuit to optional economizer board, 4-stage board, fault detection & diagnostics board, netstat and/or Multi Touch gateway
J8	6-pin phone jack connector	Incorporates the SA BUS terminals for convenience/alternate connection of SA BUS devices, primarily used for temporary service connection of the Multi Touch gateway
Item Integrated user interface at lower left corner of UCB		
Display	On-board, 2-line x 8-character back-lit display	On-board display, buttons and joystick allow access to UCB, economizer, 4-stage and FDD board parameters
ENTER	Button for display menu acknowledgment and navigation	
CANCEL	Button for display menu navigation and zeroing of active compressor ASCD timer	
JOY	4-way Joystick for display menu navigation	
Item USB connector at right of UCB		
J10	Type A female Universal Serial Bus connector	Used for backup, restoration, & copying of board parameters as well as board software updating through a flash drive

Table 21: Smart Equipment™ UCB Details (Continued)

Description		Function & Comments
J15	Factory wired SA Bus connector	
Optional communication sub-board at center of UCB		
Terminal FC¹ BUS connections on left edge of the communication board		
FC+	FC ("Field Connected") BUS BACnet MSTP communication	Positive of the VDC (typically, a fluctuating 1.5 to 3.5 volts reading to COM; at least 0.25 volts higher than -) FC bus BACnet MSTP communication circuit
FC-	FC ("Field Connected") BUS BACnet MSTP communication	Positive of the VDC (typically, a fluctuating 1.5 to 3.5 volts reading to COM; at least 0.25 volts lower than +) FC bus BACnet MSTP communication circuit
COM	Common for the FC ("Field Connected") BUS BACnet MSTP communication circuit	Negative of the VDC FC bus BACnet MSTP communication circuit
SHLD	Shield for the FC ("Field Connected") BUS BACnet MSTP communication circuit	Earth ground reference of the cable to prevent interference on the FC bus BACnet MSTP communication circuit
Item Selector in red housing at left on top edge of the communication board		
EOL switch	End Of Line selector switch for the FC BUS BACnet MSTP communication circuit	ON selected only for the UCB that is the terminus of the FC bus BACnet MSTP communication cable to prevent signal "bounce-back"
LEDs on the communication board		
EOL	Green End Of Line indicator	Lit indicates the EOL switch is selected ON
FC BUS	Green FC bus communication transmission indicator	Lit/flickering indicates outgoing UCB FC bus communication is currently active, off indicates the UCB is awaiting incoming FC bus communication
ISO PWR	Green communication board Isolated Power indicator	Lit indicates the UCB is supplying power to the communication sub-board

1. When wiring unit and other devices using the SA Bus and FC Bus, see Table 22.

Table 22: Cable for FC Buses and SA Buses in Order of Preference

Bus and Cable Type	Non-Plenum Applications		Plenum Applications	
	Part Number	O.D.	Part Number	O.D.
FC Bus: 22 AWG Stranded, 3-Wire Twisted Shielded Cable ¹	Anixter: CBL-22/3-FC-PVC Belden®: B5501FE	0.138 in.	Anixter: CBL-22/3-FC-PLN Belden: B6501FE	0.140 in.
SA Bus (Terminal Block): 22 AWG Stranded, 4-Wire, 2 Twisted-Pair Shielded Cable	Anixter: CBL-22/2P-SA-PVC Belden: B5541FE	0.209 in.	Anixter: CBL-22/2P-SA-PLN Belden: B6541FE	0.206 in.
SA Bus (Modular Jack): 26 AWG Solid 6-Wire, 3 Twisted-Pair Cable ²	—	—	Anixter preassembled: CBL-NETWORK25 CBL-NETWORK50 CBL-NETWORK75 CBL-NETWORK100	0.15 in.
FC Bus: 22 AWG Stranded, 3-Wire Twisted Non-Shielded Cable	Belden: B5501UE	0.135 in.	Belden: B6501UE	0.131 in.
SA Bus (Terminal Block): 22 AWG Stranded, 4-Wire, 2 Twisted-Pair Non-Shielded Cable	Belden: B5541UE	0.206 in.	Belden: B6541UE	0.199 in.

1. We strongly recommend 3-wire (for FC bus) and 4-wire, 2 twisted-pair (for SA bus), 22 AWG stranded, shielded cable. A 22 gauge cable offers the best performance for various baud rates, cable distances, and number of trunk devices primarily due to lower conductor-to-conductor capacitance. Shielded cable offers better overall electrical noise immunity than non-shielded cable. Observe the shield grounding requirements.
2. We recommend 26 AWG solid, 6-wire (3 twisted pairs) cable as the best fit for fabricating modular cables with the modular jack housing assembly. Be sure the cable you use fits the modular jack housing. The preassembled cables that are available from Anixter (Part No. CBL-NETWORKxxx) use 24 gauge wire.

Operation

Compressor Operation

Compressor Operation details include:

- a. Compressors are controlled by the Y1 through Y2 thermostat inputs. If the Lead/Lag function is turned OFF, a Y1 input energizes the C1 output when the compressor number 1 anti-short cycle delay is at 0 and all refrigerant safety devices are closed (Default 5 minutes).
- b. The FAN output for indoor fan operation energizes with any cooling output after the Indoor Fan Cool On Delay expires.
- c. When the thermostat cooling inputs are lost **and** the minimum runtime expires, the compressor outputs stage off (Default 3 minutes).
- d. A 30 second interstage delay occurs when multiple stages are requested.

NOTE: A Y2 input without a Y1 input energizes a C1 first and then C2 30 seconds later.

IntelliSpeed Supply Fan Control

1. Setpoints and related data

• Fan Control Type	Fixed Variable
• Occupied, No Heat Or Cool % Command	0-100%
• Occupied, One Stage of Cool % Command	0-100%
• Occupied, Two Stage of Cool % Command	0-100%
• Occupied, One Stage of Heat % Command	0-100%
• Occupied, Two Stage of Heat % Command	0-100%
• Economizer Minimum Position	0-100%
• Economizer Minimum Position for Low Speed Fan	0-100%
2. Outputs
 - 24 VAC from FAN on Unit Control Board (UCB) to enable VFD.
 - 2-10 VDC from VFD terminal on UCB for controlling speed of the VFD drive.
3. VFD Operation
 - 2-10vdc output from VFD terminal on UCB will operate supply fan VFD proportional to the min and max frequency settings of VFD drive (defaults 25hz - 60hz)
4. Supply Fan Only Operation
 - When there is no demand for heating or cooling, the supply fan to run operate at the percent output that relates to the "No Heat Or Cool % Command" setpoint.
5. Cooling Supply Fan Operation
 - With a demand for Cooling Stage 1 only, VFD will operate at the frequency relating to setpoint "Occupied, One Stage of Cool % Command"
 - With a demand for Two Cooling Stages, VFD will operate at the frequency relating to setpoint "Occupied, One Stage of Cool % Command"

Economizer Sequences

Several functions can drive the economizer, including: minimum position, free cooling, economizer loading, and minimum outdoor air supply.

Economizer Minimum Position

The economizer minimum position is set during occupied mode when outside air is not suitable for free cooling. The position of the damper is set proportionally between the "Economizer Minimum Position and the Economizer Minimum Position Low Speed Fan" set points, in relationship to the VFD output percentage. On a constant volume single speed supply fan system both set-points should be set to the same value.

Free Cooling

Four types of free cooling options are available: dry bulb changeover, single enthalpy, dual enthalpy changeover, and Auto.

Dry Bulb Changeover

For dry bulb economizer operation, the outside air is suitable for free cooling if the outside air temperature is 1°F below the Economizer OAT Enable Setpoint **and** 1°F below the Return Air Temperature.

Free cooling is no longer available if the outside air temperature rises above **either** the Economizer OAT Enable setpoint **or** the return air temperature.

Single Enthalpy Changeover

For single enthalpy economizer operation, the outside air is suitable for free cooling if the outside air enthalpy is at least 1 BTU/lb below the Economizer Outside Air Enthalpy Setpoint **and** the outside air temperature is no greater than the RAT plus 9°F.

If the outside air temperature rises above the RAT plus 10°F, free cooling is no longer available. The outside air temperature must drop to no greater than RAT plus 9°F to enter free cooling again.

Free cooling is no longer available if the outside air enthalpy rises above the Economizer Outside Air Enthalpy Setpoint.

Dual Enthalpy Changeover

For dual enthalpy economizer operation, the outside air enthalpy must be lower than the return air enthalpy by 1 btu/lb **AND** the outside air temperature is no greater than the RAT plus 9°F.

Auto

The control determines the type of free cooling changeover based on which sensors are present and reliable. Conditions include:

- Return and outside air dry bulb = dry bulb changeover

- Return and outside air dry bulb and outside air humidity = single enthalpy
- Return and outside air dry bulb and return and outside air humidity = dual enthalpy
- If either the return or outside air dry bulb sensors are unreliable, free cooling is not available

Free Cooling Operation

When the control determines that the outside air is suitable, the first stage of cooling will always be free cooling.

Thermostat

In free cooling, with a thermostat input to Y1, the dampers modulate to control the supply air temperature to the Economizer Setpoint +/- 1°F (default 55°F).

If the thermostat provides an input to Y2 **and** the parameter Compressors Off in Free Cooling is turned OFF a compressor output energizes. The economizer dampers continue to modulate to control the supply air temperature to the Economizer Setpoint.

If the supply air temperature cannot be maintained within 5°F of the economizer setpoint, the first stage compressor (C1) will be turned on. Second stage compressor (C2) will be added as needed to keep the supply air temperature within the 5°F of the economizer setpoint.

Sensor

In free cooling, with a demand from the zone/return sensor for the first stage of cooling, the dampers modulate to control the supply air temperature to the Economizer Setpoint +/- 1°F.

If the economizer output is at 100% **and** the SAT is greater than the Economizer setpoint + 1°F, the control starts a 12-minute timer to energize a compressor output.

If at any time the economizer output drops below 100% the timer stops and resets when the economizer output returns to 100%.

Once a compressor output is turned ON, the economizer dampers continue to modulate to control the supply air temperature to the Economizer Setpoint.

At no time will a compressor output be turned ON if the economizer output is less than 100%, even if the differential between zone (or return) temperature and the current cooling setpoint is great enough to demand more than one stage of cooling.

If the economizer output goes to minimum position **and** the SAT is less than Economizer Setpoint -1°F, the control starts a 12-minute timer to de-energize a compressor output.

If at any time the economizer output goes above the minimum position the timer stops and resets when the economizer output returns to minimum position.

If the demand for cooling from the space/return is satisfied, the economizer output will modulate to minimum position and the compressor outputs will be de-energized as long as their minimum run timers have expired.

Economizer Loading

Power Exhaust

Setpoints

a. Economizer Enable	ON
b. Power Exhaust Enable	ON
c. Modulating Power Exhaust	OFF
d. Exhaust VFD Installed	OFF
e. Building Pressure Sensor Enabled	OFF
f. Econo Damper Position For Exh Fan	ON Percent
g. Econo Damper Position For Exh Fan	OFF Percent

Inputs

No inputs are present for non-modulating power exhaust.

Outputs

- 2-10 VDC from ECON on Economizer Expansion module
- 24 VAC from EX-FAN to energize exhaust fan on Economizer Expansion module

Operation

Operation details include:

- Compares economizer output to the Economizer Damper Position For Exhaust Fan On and OFF.
- Energizes exhaust fan when economizer output is above Economizer Damper Position For Exhaust Fan On.
- De-energizes exhaust fan when economizer output is below the Economizer Damper Position for Exhaust Fan OFF



Figure 21: SE-ECO1001-1 Economizer Controller

Table 23: Smart Equipment™ Economizer Board Details

Board Label	Cover Label	Description	Function & Comments
Directional orientation: viewed with the center text of the cover label upright			
ANALOG INPUTS Terminal at left on upper edge of economizer board			
C	COM	24 VAC common/0-10 VDC negative for economizer actuator position feedback	Connects through circuit trace to 24V~ IN pin COM
IN2	ECOFB	0-10 VDC positive input from Economizer actuator position Feedback	EconDampPos parameter reports input status (0-100%). Used to meet Cali. Title 24 requirements for economizer actuator position feedback
R	24V~	24 VAC hot supplied for economizer actuator position feedback	Connects through circuit trace to 24V~ IN pin HOT
C	COM	Mixed Air Temperature sensor input from 10KΩ @ 77°F, Type III negative temperature coefficient thermistor	MAT parameter reports input status (°F/°C), 3.65 VDC reading MAT (+) to COM (-) with open circuit. Read-only use in current control revision.
IN1	MAT		
LEDs at left on upper edge of economizer board			
POWER	POWER	Green UCB power indicator	Lit indicates 24 VAC is present at 24V~ IN COM and HOT pins
FAULT	FAULT	Red networking error and firmware error indicator	1/10th second on/off flashing indicates a networking error (polarity, addressing, etc.) or a firmware error (likely correctable with re-loading from USB flash drive)
SA BUS	SA BUS	Green UCB SA bus communication transmission indicator	Lit/flickering indicates UCB-to-economizer board SA bus communication is currently active, off indicates the economizer board is awaiting SA bus communication

Table 23: Smart Equipment™ Economizer Board Details (Continued)

Board Label	Cover Label	Description	Function & Comments
SA BUS¹ Pin connections at left on upper edge of economizer board			
C	COM	Common for SA BUS power and communication circuits	EconCtrlr parameter reports UCB-to-economizer board SA bus communication status. Negative of the SA BUS communication circuit to the UCB. Through the unit wiring harness, may continue on to the 4-stage board and/or fault detection & diagnostics board
-	-	Communication for SA BUS devices	EconCtrlr parameter reports UCB-to-economizer board SA BUS communication status. Positive of the VDC (typically, a fluctuating 1.5 to 3.5 volts reading to C; at least 0.25 volts lower than +) SA BUS communication circuit to the UCB. Through the unit wiring harness, may continue on to the 4-stage board and/or fault detection & diagnostics board
+	+	Communication for SA BUS devices	EconCtrlr parameter reports UCB-to-economizer board SA BUS communication status. Positive of the VDC (typically, a fluctuating 1.5 to 3.5 volts reading to C; at least 0.25 volts higher than -) SA BUS communication circuit to the UCB. Through the unit wiring harness, may continue on to the 4-stage board and/or fault detection & diagnostics board
ANALOG OUTPUTS Pin at center on upper edge of economizer board			
J4	EX VFD	2-10 VDC positive output for the modulating power Exhaust fan Variable Frequency Drive/ discharge damper modulating power exhaust actuator	ExFanVFD parameter reports output status (0-100%) when ExFType selection is Variable Frequency Fan; EAD-O parameter reports output status (0-100%) when ExFType selection is Modulating Damper. Used to ramp the power exhaust fan VFD/ position the discharge damper actuator.
	COM	24 VAC common/0-10 VDC negative for the power exhaust variable frequency drive/ discharge damper modulating power exhaust actuator	Connects through circuit trace to 24V~ IN pin COM
	24V~	24 VAC hot supplied for the discharge damper modulating power exhaust actuator and economizer actuator	Connects through circuit trace to 24V~ IN pin HOT
	ECON	2-10 VDC output for the Economizer actuator	Econ parameter reports output status (0-100%). Used to position the economizer actuator for minimum position, free cooling, demand ventilation, cooling economizer loading and purge functions
	COM	24 VAC common/0-10 VDC negative for economizer actuator	Connects through circuit trace to 24V~ IN pin COM
BINARY OUTPUTS Pin at right on upper edge of economizer board			
J3	24V~	24 VAC hot supplied for an incremental (floating control) economizer actuator	Connects through circuit trace to 24V~ IN pin HOT
	ACT-A	24 VAC hot outputs to position an incremental (floating control) economizer actuator	Unused in current control revision
	ACT-B	24 VAC return	Unused in current control revision
	COM	24 VAC common for an incremental (floating control) economizer actuator	Connects through circuit trace to 24V~ IN pin COM
	EX-FAN	24 VAC hot output to energize power exhaust fan contactor coil/VFD enable relay coil	ExFan parameter reports output status (Off-On) when ExFType selection is Non-Modulating, Modulating Damper or Variable Frequency Fan. Used to turn on/enable the power exhaust fan motor.
	COM	24 VAC common/0-10 VDC negative for economizer actuator	Connects through circuit trace to 24V~ IN pin COM

Table 23: Smart Equipment™ Economizer Board Details (Continued)

Board Label	Cover Label	Description	Function & Comments
24V~ IN Pin connections at right on upper edge of economizer board			
C	COM	24 VAC transformer Common referenced to cabinet ground	24 VAC common connection to power the economizer board. Connects through circuit traces to C/COM terminals and pins distributed on the economizer board.
R	HOT	24 VAC transformer HOT	24 VAC hot connection to power the economizer board. Connects through circuit traces to R/24V~ terminals and pins distributed on the economizer board.
ANALOG INPUTS Terminal on lower edge of economizer board			
R	24V~	24 VAC hot supplied for the outdoor air humidity sensor	Connects through circuit trace to 24V~ IN pin HOT
IN3	OAH	0-10 VDC positive input from the Outdoor Air Humidity sensor	OAH parameter reports input status (0-100%H). Used in outdoor air enthalpy calculation for dual enthalpy economizer free cooling changeover.
C	COM	24 VAC common/0-10 VDC negative for the outdoor air humidity sensor	Connects through circuit trace to 24V~ IN pin COM
R	24V~	24 VAC hot supplied for the supply air humidity sensor	Connects through circuit trace to 24V~ IN pin HOT
IN4	SAH	0-10 VDC positive input from the Supply Air Humidity sensor	SAH parameter reports input status (0-100%H). Unused in current control revision.
C	COM	24 VAC common/0-10 VDC negative for the supply air humidity sensor	Connects through circuit trace to 24V~ IN pin COM
R	24V~	24 VAC hot supplied for the indoor air quality sensor	Connects through circuit trace to 24V~ IN pin HOT
IN5	IAQ	0-10 VDC positive input from the Indoor Air Quality sensor	IAQRange parameter sets the CO2 parts per million measured by the indoor air quality sensor when it outputs 10 VDC; IAQ parameter reports input status (0-5000ppm). Used for demand ventilation functions if the NetIAQ parameter indicates ?Unrel.
C	COM	24 VAC common/0-10 VDC negative for the indoor air quality sensor	Connects through circuit trace to 24V~ IN pin COM
R	24V~	24 VAC hot supplied for the outdoor air quality sensor	Connects through circuit trace to 24V~ IN pin HOT
IN6	OAQ	0-10 VDC positive input from the Outdoor Air Quality sensor	OAQRange parameter sets the CO2 parts per million measured by the outdoor air quality sensor when it outputs 10 VDC; OAQ parameter reports input status (0-5000ppm). Used for demand ventilation function when DVent-Mode selection is Diff between IAQ and OAQ and the NetOAQ parameter indicates ?Unrel.
C	COM	24 VAC common/0-10 VDC negative for the outdoor air quality sensor	Connects through circuit trace to 24V~ IN pin COM
R	24V~	24 VAC hot supplied for the air monitoring station sensor	Connects through circuit trace to 24V~ IN pin HOT
IN7	FR AIR	0-10 VDC positive input from the air monitoring station sensor	MOA-Range parameter sets the cubic feet per minute/liters per second measured by the air monitoring station sensor when it outputs 10 VDC; Fr Air parameter reports input status (0-50000CFM/23595lps). Used for economizer minimum position reset in speed-controlled indoor blower applications.
C	COM	24 VAC common/0-10 VDC negative for the air monitoring station sensor	Connects through circuit trace to 24V~ IN pin COM

Table 23: Smart Equipment™ Economizer Board Details (Continued)

Board Label	Cover Label	Description	Function & Comments
R	24V~	24 VAC hot supplied for the building pressure sensor	Connects through circuit trace to 24V~ IN pin HOT
IN8	BLDG PRES	0-5 VDC positive input from the Building Pressure sensor	BldgPres parameter reports input status (-.250-.250"/w/-.062-.062kPa). Used for modulating power exhaust functions when ExFType selection is Modulating Damper or Variable Frequency Fan.
C	COM	24 VAC common/0-5 VDC negative for the building pressure sensor	Connects through circuit trace to 24V~ IN pin COM
BINARY INPUTS at right on lower edge of economizer board			
IN9	PURGE	24 VAC hot input from the PURGE dry contact	Purge parameter reports input status (False with 0 VAC input-True with 24 VAC input). When Purge status is True, heating and cooling operation is prevented, the indoor blower and power exhaust fan operate, the economizer actuator is positioned to 100%.
	24V~	24 VAC hot supplied for the purge dry contact	Connects through circuit trace to 24V~ IN pin HOT
IN10	EX VFD FLT	24 VAC hot input from the power Exhaust Variable Frequency Drive Fault contact	ExFanVFDFlt parameter reports input status (Normal with 0 VAC input-Alarm with 24 VAC input) when ExFType selection is Variable Frequency Fan. When ExFanVFDFlt status is Alarm, EX-FAN fan output is prevented.
	24V~	24 VAC hot supplied for the power exhaust variable frequency drive fault contact	Connects through circuit trace to 24V~ IN pin HOT

1. When wiring unit and other devices using the SA Bus and FC Bus, see Table 22.

Indoor Air Quality AQ

Indoor Air Quality (indoor sensor input): Terminal AQ accepts a +2 to +10 VDC signal with respect to the (AQ1) terminal. When the signal is below its set point, the actuator is allowed to modulate normally in accordance with the enthalpy and mixed air sensor inputs. When the AQ signal exceeds its set point and there is no call for free cooling, the actuator is proportionately modulated from the 2 to 10 VDC signal, with 2 VDC corresponding to full closed and 10 VDC corresponding to full open. When there is no call for free cooling, the damper position is limited by the IAQ Max damper position setting. When the signal exceeds its set point (Demand Control Ventilation Set Point) setting and there is a call for free cooling, the actuator modulates from the minimum position to the full open position based on the highest call from either the mixed air sensor input or the AQ voltage input.

- Optional CO₂ Space Sensor Kit Part # 2AQ04700524B
- Optional CO₂ Sensor Kit Part # 2AQ04700624C

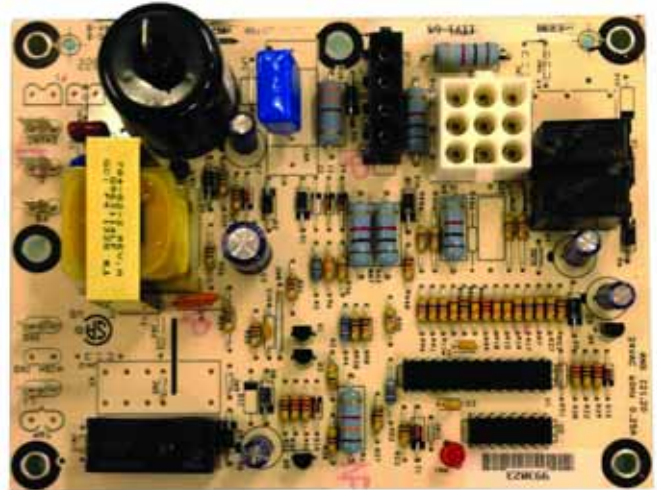

Figure 22: Ignition Control Board

Gas Heating Operation

- Heating stages are controlled by the W1 through W2 thermostat inputs. A W1 or W2 input energizes a H1 or H1/H2 output.
- When the pre-ignition process is complete the ignition module energizes the gas valve and provides a 24 V input to the MV terminal on the UCB.

- c. The FAN ON HEAT DELAY timer starts as soon as 24 V is present on MV terminal. When the timer expires the FAN output for the indoor fan operation energizes. If 24 V is not received on the MV terminal within 6 minutes, an alarm appears and the fan output energizes immediately and remains On until the alarm clears.
- d. When the thermostat heat inputs are lost **and** the 120 second Minimum Heat Run Timers have expired, heating outputs stage off. The FAN OFF HEAT DELAY timer starts when 24 V is removed from the MV terminal. When the timer expires, the FAN output for the indoor fan operation de-energizes.

NOTE: If 24 V is lost on the MV terminal during the same heat cycle, an alarm appears and the fan output energizes **and** remains On until 24 V is present again on the MV terminal.

NOTE: If 24 V is present on the MV terminal without a call for heat, an alarm appears and the fan output energizes. If this condition occurs for 6 minutes an alarm appears, and remains, until the alarm condition is cleared.

- e. At any time, if 24 V is lost on the LIMIT terminal, the FAN output for indoor fan operation is energized. If 24 V is lost on the LIMIT input 3 times in 1 hour, an alarm appears and the FAN output is energized. The heating H1 and H2 outputs are de-energized until the alarm is cleared.

Gas Heat Ignition Control Board Function

Ignition Control Board on Standby

The Ignition Control Board (ICB) has all outputs de-energized and monitors the thermostat and flame sense. The ICB resets ignition trial and flame loss counters. The ICB begins a call for heat when W1 is energized at the Unit Control Board (UCB). The ICB ignores W2 until ignition has been established.

Call for heat

The ICB checks to see if the pressure switch is open. If the pressure switch is closed, the ICB flashes "3" on the LED and waits indefinitely for it to open. When the pressure switch is sensed as open, the ICB begins pressure switch proving period. If the call for heat is lost, the ICB goes back to Standby.

Pressure switch proving

The ICB energizes the induced draft motor and waits for the low pressure switch to close. When the low pressure switch closes, the control begins Pre-purge period. If the call for heat is lost, the control de-energizes the inducer without post-purge and returns to standby.

If the low pressure switch does not close within 10 seconds of inducer energizing, the control flashes "2" on the LED. If the pressure switch does not close within 5 minutes of inducer energizing, the control shuts off the inducer for 30 seconds, then energizes the inducer for another 5 minute try to close the

pressure switch. This cycle continues indefinitely until either the pressure switch is proved closed, or the call for heat ends.

Pre-purge

The ICB monitors the low pressure switch and ensures it remains closed during pre-purge. If the pressure switch opens, the control goes back to pressure switch proving mode. The control waits for a 15 second pre-purge period, then begins the ignition trial.

Ignition trial period

The ICB energizes the main gas valve, second stage gas valve and spark outputs for a 10 second Ignition trial. The control de-energizes the spark when flame is sensed and enters a flame stabilization period.

If flame is not established within the ignition trial period, the control de-energizes the spark and gas valve and checks for maximum number of ignition trials. The ICB has a maximum number of 3 ignition trials. If the control has attempted the maximum number of ignition trials within the same call for heat without flame, the control will lockout flashing "4" on the LED. If the control has attempted less than maximum ignition trials, it begins an inter-purge period before attempting another ignition trial.

If the call for heat is lost during an ignition trial period, the control immediately de-energizes spark and gas. The control runs the inducer motor through a post purge period before de-energizing.

If the pressure switch is lost during an ignition trial period, the control immediately de-energizes spark and gas. The control begins pressure switch proving before an inter-purge and re-ignition attempt.

Flame stabilization period

If a flame is detected during the Ignition Trial Period, the ICB then enters the flame stabilization period. If a flame is not detected in 2 seconds, the main valve is de-energized and a retry operation begins. The flame stabilization period lasts 10 seconds. flame detection must be lost for 2 seconds during flame stabilization for the main valve to be de-energized. When the flame stabilization period has ended, a loss of flame detection for 3/4 seconds will result in the main valve being de-energized.

If flame is lost during the flame stabilization period, the control counts it as a flame loss and retries ignition or locks out as described in Low heat section.

Main Burner operation

High heat warm-up

Two stage models run high heat for the first 30 seconds following flame stabilization period regardless of W2 demand. If W2 is not energized at the end of this 30 second period the control de-energizes the high gas output. If W2 is energized the control remains on high heat.

Low heat

The ICB keeps the main gas valve and induced draft motor energized while continuously monitoring the call for heat, low pressure switch, and flame status.

If the call for heat (W1) is lost, the control de-energizes the gas valve and begins post purge.

If low pressure switch opens, the control de-energizes the gas valve and begins pressure switch proving mode.

If flame is lost, the control de-energizes the gas valve within 2.0 second and counts the flame loss. If flame has been lost more than 5 times within the same call for heat, the control locks out flashing "5" on the LED. If flame has been lost less than 5 times, the control attempts re-ignition after a 30 second inter-purge period.

High heat

The ICB recognizes a call for 2nd stage heat when W2 is energized. The control energizes the high gas output.

If the call for 2nd stage heat goes away and the 1st stage call remains, the control de-energizes the high gas valve and returns to low heat operation.

Response to loss of W1, low pressure switch, and flame are identical to low heat operation.

Post Purge

The ICB runs the induced draft motor for a 5 second post-purge period, then de-energizes the inducer. If a call for heat occurs during post-purge, the control finishes the post-purge, drops inducer out to re-prove open pressure switch before continuing with the heat cycle.

Lockout

While in lockout, the ICB keeps the main gas valve and induced draft motor de-energized.

Lockouts due to failed ignition or flame losses may be reset by removing the call for heat (W1) for more than 1 second, but less than 20 seconds, or by removing power from the control for over 0.25 seconds. The control will automatically reset lockout after 60 minutes.

Lockouts due to detected internal control faults will reset after 60 minutes or power interruption.

High temperature limit switch

If the high temperature limit switch is open the control will run the inducer, de-energize the gas valve, and flash "6" on the LED. When the high temperature switch closes, the control will restart the ignition sequence beginning with pre-purge.

If the high temperature limit is open for more than 6 minutes continuously during a call for heat, it is assumed that the main blower has failed and the control shall enter a hard lockout and flash a "9" on the LED. During the hard lockout, the control will continue to run the inducer as long as the limit switch is open. If

the limit switch recloses in this hard lockout condition, the inducer will run a post purge and then shutoff. The control shall remain locked out until power is removed and shall not reset automatically.

Roll-out switch

If the roll-out switch opens for more than 0.25 seconds, the ICB will run the inducer for a post-purge period, immediately de-energize the gas valve, and flash "7" on the LED.

If the roll-out switch closes, the control shall remain locked out until power removed or "W" is removed. Rollout switch lockout shall not reset automatically.

Power interruptions

Power interruptions less than 0.80 seconds shall not cause the ICB to interrupt the heat sequence. Power interruptions over 0.250 seconds will cause the control reset lockout and ignition trial counters. Power interruptions of any duration shall not cause lockout or any operation requiring manual intervention.

Flame present with Gas off

If flame is sensed for longer than 2.0 seconds during a period when the gas valve should be closed, the ICB will enter lockout. The control will turn on the inducer blower while the flame is present.

Welded gas valve relay response

If either or both Main and 2nd Stage Gas valve outputs are sensed to be off for more than 1 second when commanded to be **ON** the ICB shuts off all outputs and enters lockout.

If the Main valve output is sensed to be energized for more than 1 second when commanded to be off, the control de-energizes the induced draft motor (if flame is not present) to attempt to open the pressure switch to de-energize the gas valve. If the Main gas valve is still sensed as energized after the inducer has been off for 15 seconds, the control re-energizes the inducer to attempt to vent the unburned gas. In either case, the control locks out.

Start-Up (Cooling)

Prestart Check List

After installation has been completed:

1. Check the electrical supply voltage being supplied. Be sure that it is the same as listed on the unit nameplate.
2. Set the room thermostat to the off position.
3. Turn unit electrical power on.
4. Set the room thermostat fan switch to on.
5. Check indoor blower rotation.
 - If blower rotation is in the wrong direction. Refer to Phasing Section in general information section.Check blower drive belt tension.
6. Check the unit supply air (CFM).

7. Measure evaporator fan motor's amp draw.
8. Set the room thermostat fan switch to off.
9. Turn unit electrical power off.

Operating Instructions

1. Turn unit electrical power on.

NOTE: Prior to each cooling season, the crankcase heaters where equipment must be energized at least 10 hours before the system is put into operation.

2. Set the room thermostat setting to lower than the room temperature.
3. First stage compressors will energize after the built-in time delay (five minutes).

Post Start Check List

1. Verify proper system pressures.
2. Measure the temperature drop across the evaporator coil.

Start-Up (Gas Heat)

Pre-Start Check List

Complete the following checks before starting the unit.

1. Check the type of gas being supplied. Be sure that it is the same as listed on the unit nameplate.
2. Make sure that the vent outlet and combustion air inlet are free of any debris or obstruction.

Operating Instructions

⚠ CAUTION

This furnace is equipped with an automatic re-ignition system. **DO NOT** attempt to manually light the pilot.

Lighting The Main Burners

1. Turn "OFF" electric power to unit.
2. Turn room thermostat to lowest setting.
3. Turn gas valve switch to "ON" position (See Figures 24 and 25).
4. Turn "ON" electric power to unit.
5. If thermostat set temperature is above room temperature, the main burners will ignite.

Post Start Checklist

After the entire control circuit has been energized and the heating section is operating, make the following checks:

1. Check for gas leaks in the unit piping as well as the supply piping.

⚠ WARNING

FIRE OR EXPLOSION HAZARD

Failure to follow the safety warning exactly could result in serious injury, death or property damage.

Never test for gas leaks with an open flame. Use a commercially available soap solution made specifically for the detection of leaks to check all connections. A fire or explosion may result causing property damage, personal injury or loss of life.

2. Check for correct manifold gas pressures. (See CHECKING GAS INPUT.)
3. Check the supply gas pressure. It must be within the limits shown on the rating nameplate. Supply pressure should be checked with all gas appliances in the building at full fire. At no time should the standby gas pressure exceed 10.5 in. or the operating pressure drop below 4.5 in. for natural gas units. If gas pressure is outside these limits, contact the local gas utility or propane supplier for corrective action.

Shut Down

1. Set the thermostat to the lowest temperature setting.
2. Turn "OFF" all electric power to unit.
3. Open gas heat access panel.
4. Turn gas valve switch to "OFF" position (See Figures 24 and 25).

Checking Gas Heat Input

Single Stage Gas Heat

This unit has a single stage of gas heat. The intended input for each furnace is shown in Table 25. The table applies to units operating on 60 Hz power only.

To determine the rate of gas flow (Single Stage).

1. Turn off all other gas appliances connected to the gas meter.
2. Turn on the furnace and make sure the thermostat is calling for heat.
3. Measure the time needed for one revolution of the hand on the lowest increment dial on the meter. A typical gas meter has a 1/2 or a 1 cubic foot test dial.
4. Using the number of seconds it takes for one revolution of the dial, calculate the cubic feet of gas consumed per hour. (See example below).
5. If necessary, adjust the regulator as discussed in the section "Manifold Gas Pressure Adjustment". **Be sure not to over-fire the furnace.** If in doubt, it is better to leave the furnace slightly under-fired. Repeat Steps 1-5.

Two Stage Gas Heat

This unit has two stages of gas heat. First stage input is considered the minimum input for the furnace. The intended input for each furnace is shown in Table 25. The table applies to units operating on 60 Hz power only.

To determine the rate of gas flow (Second Stage).

1. Turn off all other gas appliances connected to the gas meter.
2. Turn on the furnace and make sure the thermostat is calling for Second stage (100% input) heat.
3. Measure the time needed for one revolution of the hand on the lowest increment dial on the meter. A typical gas meter has a 1/2 or a 1 cubic foot test dial.
4. Using the number of seconds it takes for one revolution of the dial, calculate the cubic feet of gas consumed per hour. (See example below).
5. If necessary, adjust the high pressure regulator as discussed in the section "Manifold Gas Pressure Adjustment". **Be sure not to over-fire the furnace on second stage.** If in doubt, it is better to leave the second stage of the furnace slightly under-fired. Repeat Steps 1-5.

To determine the rate of gas flow (First Stage)

1. Turn off all other gas appliances connected to the gas meter.
2. Turn on the furnace and make sure the thermostat is calling for first stage heat.
3. Even when the thermostat is calling for first stage heat, the unit will light on second stage and will run on second stage for 1 minute. Allow this one-minute time period to expire and be certain the unit is running on first stage.
4. Measure the time needed for one revolution of the hand on the lowest increment dial on the meter. A typical gas meter has a 1/2 or a 1 cubic foot test dial.
5. Using the number of seconds it takes for one revolution of the dial, calculate the cubic feet of gas consumed per hour (See example below).
6. If necessary, adjust the low pressure regulator as discussed in the section "Manifold Gas Pressure Adjustment". **Be sure not to under-fire the furnace on first stage.** If in doubt, it is better to leave the first stage of the furnace slightly over-fired (Refer to Table 25 for input value.). Repeat Steps 1-6.

Table 24: Gas Rate Cubic Feet Per Hour

Seconds for One Rev.	Size of Test Dial	
	1/2 cu. ft.	1 cu. ft.
10	180	360
12	150	300
14	129	257
16	113	225
18	100	200
20	90	180
22	82	164
24	75	150
26	69	138
28	64	129
30	60	120
32	56	113
34	53	106
36	50	100
38	47	95
40	45	90
42	43	86
44	41	82
46	39	78
48	37	75
50	36	72
52	35	69
54	34	67
56	32	64
58	31	62
60	30	60

NOTE: To find the Btu input, multiply the number of cubic feet of gas consumed per hour by the Btu content of the gas in your particular locality (contact your gas company for this information as it varies widely from area to area).

EXAMPLE

By actual measurement, it takes 46 seconds for the hand on a 1 cubic foot dial to make a revolution with a 80,000 Btuh furnace running. To determine rotations per minute, divide 60 by 46 = 1.30. To calculate rotations per hour, multiply 1.30 • 60 = 78. Multiply 78 • 1 (0.5 if using a 1/2 cubic foot dial) = 78. Multiply 78 • (the Btu rating of the gas). For this example, assume the gas has a Btu rating of 1050 Btu/ft.³. The result of 81,900 Btuh is within 5% of the 80,000 Btuh rating of the furnace.

Manifold Gas Pressure Adjustment

Single Stage

This gas furnace has one stage of gas heat. Therefore, the gas valve has one adjustment screw located under a cover screw on the valve (See Figure 24).

Manifold pressure adjustment procedure.

1. Turn off all power to the unit.
2. Using the outlet pressure port on the gas valve, connect a manometer to monitor the manifold pressure.
3. Remove cover screw covering the pressure adjustment screw.
4. Turn on power to the unit.

5. Set thermostat to call for heat and start furnace.
6. If necessary, using a screwdriver, turn the adjustment screw clockwise to increase manifold pressure or counterclockwise to decrease manifold pressure.
7. Once pressure has been checked, replace the plastic cap covering the pressure adjustment screw.

Two Stage

This gas furnace has two heat stages. Therefore, the gas valve has two adjustment screws located under two cover screws. The second stage adjustment screw is adjacent to the "HI" marking on the valve and the first stage adjustment screw is located adjacent to the "LO" marking on the valve (See Figure 25).

Manifold pressure adjustment procedure.

Adjust second stage (Refer to Table 25 for input value.) pressure first, then adjust first stage (Refer to Table 25 for input value.) pressure.

1. Turn off all power to the unit.
2. Using the outlet pressure port on the gas valve, connect a manometer to monitor the manifold pressure.
3. Remove cover screws covering HI and LO pressure adjustment screws.
4. Turn on power to the unit.
5. Set thermostat to call for second stage heat and start furnace.
6. If necessary, using a screwdriver, turn the second stage adjustment screw (adjacent to the "HI" marking on the valve) clockwise to increase manifold pressure or counterclockwise to decrease manifold pressure.
7. After the high manifold pressure has been checked, adjust the thermostat to call for first stage heat.
8. If necessary, using a screwdriver, turn the first stage adjustment screw (adjacent to the "LO" marking on the valve) clockwise to increase manifold pressure or counterclockwise to decrease manifold pressure.
9. Once pressure has been checked, replace the cover screws covering the HI and LO pressure adjustment screws.

Table 25: Gas Heat Stages

Model (Size)	Gas Heat Description	Opt.	# of Burner Tubes	1st Stage Input (Mbh)	2nd Stage Input (Mbh)	Total Input (Mbh)
ZQ04 (3) Single Phase	Low, NOx	L	2	-	56	56
	Low	D	2	-	70	70
	Med, NOx	M	3	-	90	90
ZQ04 (3) Three Phase	Med	E	3	-	112	112
	Low, NOx	L	2	-	56	56
ZQ04 (3) Single Phase	Low	D	2	-	70	70
	Med, NOx	M	3	-	90	90
	Med	E	3	82	112	112
ZQ05 (4) Single Phase	Low, NOx	L	2	-	56	56
	Low	D	2	-	70	70
	Med, NOx	M	3	-	90	90
ZQ05 (4) Three Phase	Med	E	3	-	112	112
	High, NOx	N	3	-	116	116
	High	F	3	-	142	142
ZQ05 (4) Single Phase	Low, NOx	L	2	-	56	56
	Low	D	2	-	70	70
	Med, NOx	M	3	-	90	90
ZQ05 (4) Three Phase	Med	E	3	-	112	112
	High, NOx	N	3	-	118	118
	High	F	3	100	145	145
ZQ06 (5) Single Phase	Low, NOx	L	2	-	56	56
	Low	D	2	-	70	70
	Med, NOx	M	3	-	90	90
ZQ06 (5) Three Phase	Med	E	3	-	112	112
	High, NOx	N	3	-	116	116
	High	F	3	-	142	142
ZQ06 (5) Single Phase	Low, NOx	L	2	-	56	56
	Low	D	2	-	70	70
	Med, NOx	M	3	-	90	90
ZQ06 (5) Three Phase	Med	E	3	-	112	112
	High, NOx	N	3	-	118	118
	High	F	3	100	145	145

Adjustment Of Temperature Rise

The temperature rise (the difference of temperature between the return air and the heated air from the furnace) must lie within the range shown on the unit rating plate and the data in Table 8.

After the temperature rise has been determined, the CFM can be calculated as follows:

$$\text{CFM} = \text{Btu Input} \cdot \frac{0.8}{(1.08 \cdot \Delta^{\circ}\text{F})}$$

After about 20 minutes of operation, determine the furnace temperature rise. Take readings of both the return air and the heated air in the ducts (about 6 feet from the furnace) where they will not be affected by radiant heat. Increase the blower CFM to decrease the temperature rise; decrease the blower CFM to increase the rise (See SUPPLY AIR DRIVE ADJUSTMENT).

NOTE: Each gas heat exchanger size has a minimum allowable CFM. Below this CFM, the limit will open.

Burners/Orifices Inspection/Serviceing

Before checking or changing burners or orifices, CLOSE MAIN MANUAL SHUT-OFF VALVE AND SHUT OFF ALL POWER TO THE UNIT.

1. Open the union fitting just upstream of the unit gas valve and downstream from the main manual shut-off valve in the gas supply line.
2. Remove the screws holding each end of the manifold to the manifold supports.
3. Disconnect wiring to the gas valve. Remove the manifold & gas valve assembly. Orifices can now be inspected and/or replaced.

To service burners, complete step 4.

4. Remove the heat shield on top of the manifold supports. Burners are now accessible for inspection and/or replacement.

NOTE: Reverse the above procedure to replace the assemblies.

Make sure that burners are level and seat at the rear of the gas orifice.

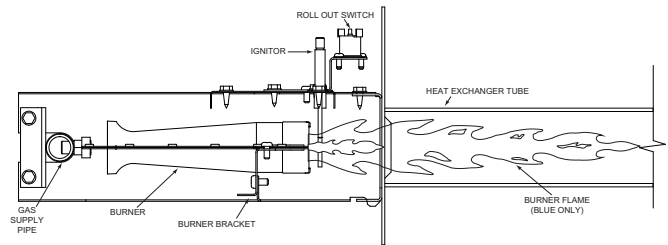

Figure 23: Typical Flame

NOTE: installation of this furnace at altitudes above 2000 ft (610 m) shall be in accordance with local codes, or in the absence of local codes, the National Fuel Gas Code, ANSI Z223.1/NFPA 54 or National Standard of Canada, Natural Gas and Propane Installation Code, CSA B149.1.

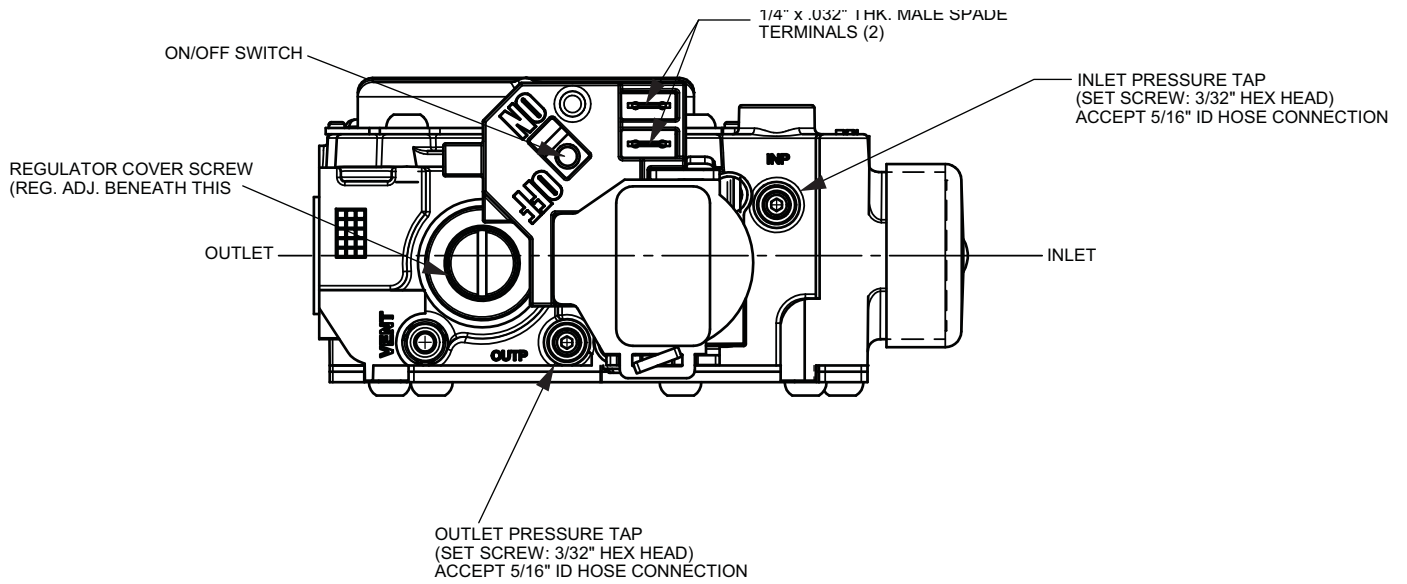

Figure 24: 3 Thru 5 Ton, 1/2" Single Stage Gas Valve

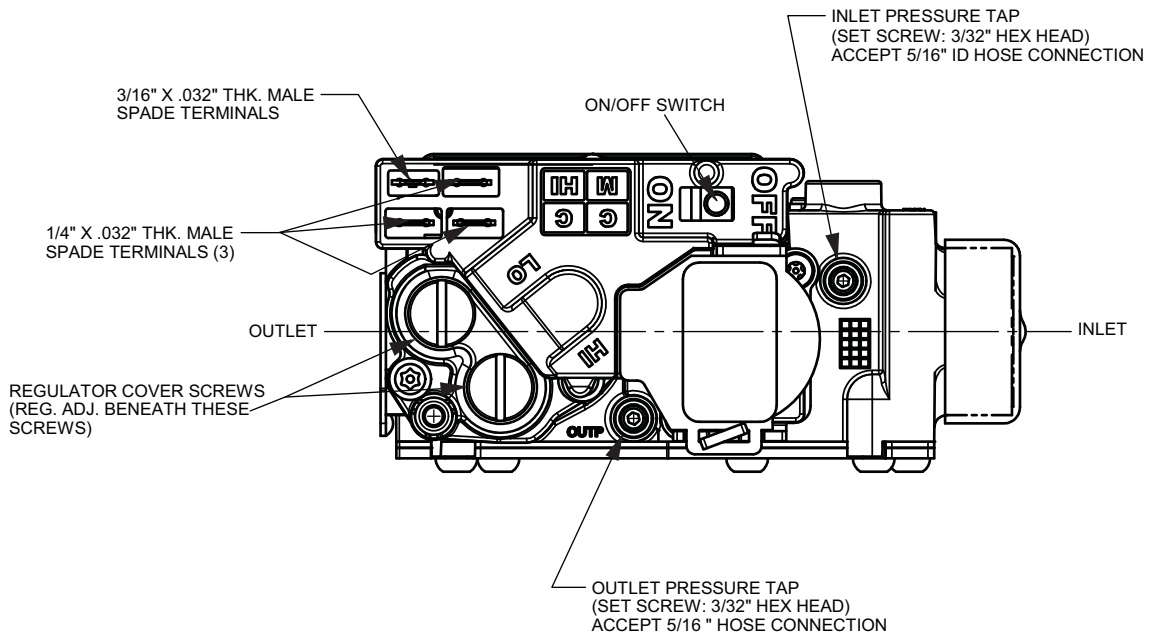

Figure 25: 3 Thru 5 Ton, 1/2" Two Stage Gas Valve

Troubleshooting

WARNING

Troubleshooting of components may require opening the electrical control box with the power connected to the unit. **Use extreme care when working with live circuits!** Check the unit nameplate for the correct line voltage and set the voltmeter to the correct range before making any connections with line terminals.

When not necessary, shut off all electric power to the unit prior to any of the following maintenance procedures so as to prevent personal injury.

CAUTION

Label all wires prior to disconnection when servicing controls. Wiring errors can cause improper and dangerous operation, which could cause injury to person and/or damage unit components. Verify proper operation after servicing.

WARNING

The furnace may shut down on a high temperature condition during the procedure. If this occurs, the UCB energize the supply air blower motor until the high temperature limit has reset. Caution should be used at all times as the supply air blower may energize regardless of the room thermostat fan switch position.

Table 26: Flash Codes for the Gas Heat Ignition Control Board

Flash Code	Description	Technician Corrective Action	Ignition Control Response to Flash Code	Method for Reset
Heartbeat	<i>Normal Operation</i> - no status or error information currently needs to be displayed	None.	All functions available to respond to heating demand.	None.
Steady Off	a. <i>No Power to the Control</i> - Less than 18 VAC is present at the ignition control's R (P2-2 pin) and C (P2-1 pin) connections	Verify line voltage is present at the primary of the 75VA transformer, verify 24 VAC is present at the secondary of the 75VA transformer. Verify 24 VAC is present from the UCB's C to SD terminals indicating the 3.2A control circuit breaker and phase monitor contacts are closed. Verify 24 VAC is present at the ignition control's R (P2-2 pin) and C (P2-1 pin) connections indicating the unit to ignition control wiring is intact.	The output relay contacts open so inducer and gas valve operation is not permitted.	a. Restoration of 24 VAC power to the ignition control.
	b. The ignition control has catastrophic damage that will not allow the LED display (it is likely that there will be visible physical evidence of the damage)			b. None.
Steady On	The Ignition Control's Microprocessor Has Not Passed its Self-check	Cycle power to the control to eliminate the possibility that transient voltage conditions such as surges, brownouts, etc. have not created a false indication. If the steady on LED indication repeats, the control will need to be replaced and potential causes for failure, such as excessive voltage, RF interference, etc. should be investigated.	The output relay contacts open so inducer and gas valve operation is not permitted.	Cycling 24 VAC power to the ignition control or expiration of the 60 minute "watchdog" timer.
2 Flashes	<i>The Induced Draft Pressure Switch Did Not Close</i> - 24 VAC was not received to the ignition control's pressure switch input (P1-8 pin) within 10 seconds of the ignition control energizing the induced draft motor or 24 VAC was later lost to the control's pressure switch input while the ignition control energized the induced draft motor	Verify that the induced draft motor is operable, the ignition control's L1 to IND contacts are not open, the induced draft blower wheel is intact and there are no blockages in the combustion air / induced draft path. Verify that the induced draft pressure switch sensing tubing is intact. With an incline manometer, digital manometer or Magnehelic® gauge teed into the pressure switch sensing line verify that the negative pressure exceeds the setting listed on the induced draft pressure switch label and the switch's contacts correctly close at the setting listed	Gas valve operation is not permitted/ends when the induced draft pressure switch input is not present. The ignition control's L1 to IND output relay contact will cycle closed for 5 minutes/open for 30 seconds until 24 VAC is received to the pressure switch input or the heating demand ends.	Closure of the pressure switch (24 VAC input to P1-8 pin), cycling first stage heat input or cycling 24 VAC power to the ignition control.

Table 26: Flash Codes for the Gas Heat Ignition Control Board

Flash Code	Description	Technician Corrective Action	Ignition Control Response to Flash Code	Method for Reset
3 Flashes	<i>The Induced Draft Pressure Switch is Stuck Closed</i> - 24 VAC is received to the control's pressure switch input (P1-8 pin) at the same time as 24 VAC to initiate heating operation is received at the control's W1 input (P2-3 pin)	Verify that the induced draft pressure switch contacts are not stuck or welded closed. Verify that the ignition control's L1 to IND contacts are not stuck or welded closed causing the induced draft motor to run continuously. Verify that the wiring from the ignition control's P1-3 pin through the induced draft pressure switch to the ignition control's pressure switch input (P1-8 pin) is not shorted.	The output relay contacts open so inducer and gas valve operation is not permitted.	Opening of the pressure switch (loss of 24 VAC input to P1-8 pin) then cycling first stage heat input or cycling 24 VAC power to the ignition control.
4 Flashes	<i>Flame Could Not Be Established</i> - A flame signal of 0.2µa or greater could not be established in three consecutive attempts for ignition at the initiation of the heating cycle	Verify that the unit has proper electrical grounding. Verify the 24 VAC common and ignition control cabinet ground references are intact. Monitor the flame signal. Verify that combustion air openings are without blockages and that the unit has proper clearance to the structure and adjacent units. Verify that the burners are clean and without blockages that could interfere with gas flow. Verify that the ignitor sparks with an ≈1/8" gap to the crossover area of the left burner. Verify that the flame sensor is intact and positioned with an ≈1/8" gap to the right burner. Verify that the gas lines have been purged of air and provide proper gas inlet pressure. Verify that the gas valve is opening and adjusted to provide proper manifold pressure. Verify that the wiring to the gas valve is intact. Verify that there is no wind, rain or snow entering the heat compartment to interfere with ignition or the burners. Verify that there are no conditioned air leaks or heat exchanger breaches to interfere with ignition or the burners.	Immediately after the third ignition trial: the gas valve output relay contact opens so gas valve operation is not permitted, following a 5 second inducer post purge the induced draft output relay contact opens so inducer operation is not permitted.	Cycling first stage heat input, cycling 24 VAC power to the ignition control or expiration of the 60 minute "watchdog" timer.
5 Flashes	<i>Flame Loss</i> - After being established during ignition trials, flame signal dropped below 0.2µa five times during one heating cycle	Verify that the unit has proper electrical grounding. Verify the 24 VAC common and ignition control cabinet ground references are intact. Monitor the flame signal. Verify that combustion air openings are without blockages and that the unit has proper clearance to the structure and adjacent units. Verify that the burners are clean and without blockages that could interfere with gas flow. Verify that the flame sensor is intact and positioned with an ≈1/8" gap to the right burner. Verify that the gas lines have been purged of air and provide proper gas inlet pressure. Verify that the gas valve provides proper manifold pressure. Verify that the wiring to the gas valve is intact. Verify that there is no wind, rain or snow entering the heat compartment to interfere with ignition or the burners. Verify that there are no conditioned air leaks or heat exchanger breaches to interfere with ignition or the burners.	Immediately after the fifth flame loss: the gas valve output relay contact opens so gas valve operation is not permitted, following a 5 second inducer post purge the induced draft output relay contact opens so inducer operation is not permitted.	Cycling first stage heat input, cycling 24 VAC power to the ignition control or expiration of the 60 minute "watchdog" timer.
6 Flashes	<i>Open Limit</i> - 24 VAC has been lost to the control's limit switch input (P1-9 pin) or 24 VAC has been lost to the control's limit switch input (P1-9 pin) for a duration of 6 minutes or less with 24 VAC present at the control's W1 input (P2-3 pin)	Verify proper gas manifold pressure. Correct the inadequate indoor airflow condition. Verify filters, indoor coil and blower wheel are clean. Verify that the blower belt is properly maintained and adjusted; the blower motor fuses are intact, contactor and motor are operable and wheel has the correct rotation. Verify that the ducting is not restrictive. Verify indoor air volume is at least the minimum required for the heat section by using the Airflow Measurement Charts in the Technical Training Manual or other method such as temperature rise, balometer, etc. Verify heating mode blower on/off delays are proper for the heat type and provide adequate heat section cooling at the termination of the heating cycle. Verify wiring for main and auxiliary limit switches is intact.	The gas valve output relay contact opens so gas valve operation is not permitted, the induced draft output relay contact closes to operate the inducer.	Closure of the limit switch(es) (24 VAC input to P1-9 pin)
7 Flashes	<i>Open Rollout</i> - 24 VAC has been lost to the control's rollout switch input (P1-6 pin)	Verify that combustion air openings are without blockages and that the unit has proper clearance to the structure and adjacent units. Verify that the burners are clean and without blockages that could interfere with gas flow. Verify that the ignitor sparks with an ≈1/8" gap to the crossover area of the left burner. Verify that the gas lines provide proper gas inlet pressure. Verify that the gas valve is adjusted to provide proper manifold pressure. Verify that there is no wind, rain or snow entering the heat compartment to interfere with ignition or the burners. Verify that there are no conditioned air leaks or heat exchanger breaches to interfere with ignition or the burners. Verify wiring for the rollout switch is intact.	The gas valve output relay contact opens so gas valve operation is not permitted, following a 5 second inducer post purge the induced draft output relay contact opens so inducer operation is not permitted.	Closure of the rollout switch (24 VAC input to P1-6 pin) then cycling first stage heat input or cycling 24 VAC power to the ignition control.

Table 26: Flash Codes for the Gas Heat Ignition Control Board

Flash Code	Description	Technician Corrective Action	Ignition Control Response to Flash Code	Method for Reset
8 Flashes	<i>The Gas Valve Failed To Shut Off</i> - flame has been sensed for longer than 2 seconds when the first stage gas valve output is off	Verify that the gas valve is not slow to shut off, leaks by or otherwise does not completely shut off gas flow when de-energized. Verify the gas valve wiring to is intact and not shorted in a manner that would improperly allow 24 VAC from another circuit to be applied to the gas valve.	The gas valve output relay contact opens so gas valve operation is not permitted, the induced draft output relay closes to operate the inducer.	Cycling 24 VAC power to the ignition control.
9 Flashes	<i>Indoor Airflow Failure Open Limit</i> - 24 VAC has been lost to the control's limit switch input (P1-9 pin) for a duration of more than 6 minutes with 24 VAC present at the control's W1 input (P2-3 pin)	Correct the no/extremely low indoor airflow condition. Verify filters, indoor coil and blower wheel are clean. Verify that the blower belt is intact, properly maintained and adjusted; the blower motor fuses are intact, contactor and motor are operable and wheel has the correct rotation. Verify that the ducting is without blockages. Verify indoor air volume is at least the minimum required for the heat section by using the Airflow Measurement Charts in the Technical Training Manual or other method such as temperature rise, balometer, etc. Verify wiring for main and auxiliary limit switches is intact. Verify main and auxiliary limit switches are not failed in an open position.	The gas valve output relay contact opens so gas valve operation is not permitted, the induced draft output relay contact closes to operate the inducer.	Cycling 24 VAC power to the ignition control.
10 Flashes	a. <i>Gas Valve Miss-wire</i> - 24 VAC has been present for longer than 1 second at the first stage and/or second stage gas valve output (P1-7 pin and/or P1-4 pin) when the gas valve is commanded off by the ignition control b. <i>Ignition Control Gas Valve Relay Contact Failed to Close</i> - 24 VAC has not been sensed for longer than 1 second at the first stage and/or second stage gas valve output (P1-7 pin and/or P1-4 pin) when the gas valve is commanded on by the ignition control	Verify gas valve wiring from the ignition control to the gas valve is intact and not shorted in a manner that would improperly allow 24 VAC from another circuit to be applied to the control's P1-7 and/or P1-4 gas valve output pins. Verify the control's gas valve output relay contacts for first stage (P1-8 to P1-7) and second stage (P1-7 to P1-4) are not shorted or fail to close when commanded on.	Initially, the output relay contacts open. Then, if 24 VAC remains present at the P1-7 pin after 15 seconds, the induced draft output relay contact closes to operate the inducer.	Cycling 24 VAC power to the ignition control.

Table 27: ZQ04 Charging Table

Air Flow Indoor Db/Wb	Outdoor DB ° F	Suction P psig	Suction Temp. ° F	Liquid P psig	Liquid Temp. ° F	Delta T Db ° F	Compr. amps
300 Cfm/Ton 80/62	75	126	62	266	77	-24	7.9
	85	130	60	310	90	-25	9.0
	95	133	57	354	102	-26	10.1
300 Cfm/Ton 80/67	75	126	62	266	77	-24	7.9
	85	132	62	312	88	-23	9.0
	95	139	62	358	100	-23	10.1
300 Cfm/Ton 80/72	75	126	61	265	76	-25	7.9
	85	135	63	314	87	-22	9.0
	95	144	66	362	98	-19	10.1
300 Cfm/Ton 75/62	75	122	58	263	78	-22	7.9
	85	127	57	308	90	-22	8.9
	95	132	55	353	102	-22	10.0
400 Cfm/Ton 80/62	75	128	65	267	77	-22	7.9
	85	133	63	313	89	-22	9.0
	95	138	62	358	100	-22	10.1
400 Cfm/Ton 80/67	75	128	65	268	76	-21	7.9
	85	135	65	314	88	-21	9.0
	95	142	65	361	99	-20	10.2
400 Cfm/Ton 80/72	75	129	65	268	76	-21	7.9
	85	137	66	316	87	-19	9.0
	95	146	68	363	98	-18	10.2
400 Cfm/Ton 75/62	75	125	61	265	77	-20	7.9
	85	130	60	311	89	-19	9.0
	95	136	59	357	101	-19	10.1

Table 28: ZQ05 Charging Table

Air Flow Indoor Db/Wb	Outdoor DB ° F	Suction P psig	Suction Temp. ° F	Liquid P psig	Liquid Temp. ° F	Delta T Db ° F	Compr. amps
300 Cfm/Ton 80/62	75	128	57	277	82	-27	10.8
	85	129	54	320	94	-28	12.3
	95	131	50	363	106	-28	13.8
300 Cfm/Ton 80/67	75	132	64	277	81	-25	10.8
	85	137	61	323	92	-24	12.4
	95	143	59	368	103	-23	13.9
300 Cfm/Ton 80/72	75	137	70	278	80	-23	10.8
	85	146	69	325	90	-21	12.4
	95	154	68	373	101	-18	14.0
300 Cfm/Ton 75/62	75	121	50	271	83	-26	10.7
	85	124	47	316	94	-26	12.2
	95	127	45	360	106	-26	13.7
400 Cfm/Ton 80/62	75	132	63	280	80	-23	10.9
	85	136	61	325	92	-23	12.4
	95	140	58	370	104	-23	14.0
400 Cfm/Ton 80/67	75	136	66	283	80	-22	11.0
	85	141	65	328	91	-21	12.5
	95	147	63	373	103	-20	14.0
400 Cfm/Ton 80/72	75	140	69	286	79	-20	11.0
	85	147	69	331	90	-19	12.5
	95	153	68	377	101	-17	14.0
400 Cfm/Ton 75/62	75	127	57	276	81	-21	10.8
	85	132	55	322	93	-21	12.3
	95	136	53	367	104	-21	13.9

Table 29: ZQ06 Charging Table

Air Flow Indoor Db/Wb	Outdoor DB ° F	Suction P psig	Suction Temp. ° F	Liquid P psig	Liquid Temp. ° F	Delta T Db ° F	Compr. amps
300 Cfm/Ton 80/62	75	129	63	280	79	-24	13.5
	85	132	59	323	90	-25	15.2
	95	136	54	366	102	-26	16.9
300 Cfm/Ton 80/67	75	129	64	279	78	-25	13.5
	85	135	61	325	90	-24	15.3
	95	142	59	371	101	-23	17.1
300 Cfm/Ton 80/72	75	130	65	279	78	-25	13.5
	85	139	64	328	89	-23	15.4
	95	147	64	377	100	-20	17.3
300 Cfm/Ton 75/62	75	125	58	277	79	-22	13.4
	85	129	54	321	90	-22	15.2
	95	133	50	365	102	-22	16.9
400 Cfm/Ton 80/62	75	132	67	282	78	-22	13.6
	85	138	65	327	112	-22	15.3
	95	143	62	371	146	-22	17.1
400 Cfm/Ton 80/67	75	133	68	284	78	-21	13.7
	85	140	66	329	125	-21	15.4
	95	146	65	375	171	-20	17.2
400 Cfm/Ton 80/72	75	134	68	285	78	-21	13.7
	85	142	68	331	137	-20	15.5
	95	149	68	378	196	-18	17.3
400 Cfm/Ton 75/62	75	129	62	279	78	-19	13.5
	85	134	60	324	101	-19	15.3
	95	140	58	369	124	-19	17.0

Control Board Navigation Components

The following components are needed to access the control points in the Smart Equipment™ control. Installation and operation guides are located on www.upgnet.com under Product Center \ Equipment Catalog \ Commercial Products \ Zoning Systems and Controls.

1. Local LCD on Unit Control Board.

OR

2. Mobile Access Portal (MAP) Gateway (Portable).

- Source 1 P/N S1-JC-MAP1810-OP
- MAP Gateway Quick Start Guide P/N 24-10737-16
- MAP Gateway Instruction P/N 24-10737-8

NOTE: For more in-depth sequence of operation of the Smart Equipment™ control please refer to LIT-12011950 on www.upgnet.com under Product Center \ Equipment Catalog \ Commercial Products \ Zoning Systems and Controls.

SMART EQUIPMENT™ FIRMWARE VERSION 3.3 BASIC UNIT CONTROL BOARD NAVIGATION EXAMPLES:

The following document details the navigation and viewing of the LCD display screen equipped as a standard item on the Smart Equipment™ control installed within various commercial UPG packaged and split system equipment. The following information provides a step-by-step demonstration on how to

navigate the basic status menu and how to change basic configuration settings. The basic navigation steps outlined in this short demonstration applies to most menus within the Smart Equipment™ control.



Understanding the Local LCD

After you apply power to your Rooftop Unit (RTU), a start-up countdown begins on the Unit Control Board (UCB) LCD. When the controller is ready, the screen is blank because no faults are present. Use the joystick and the two push buttons below the LCD, to navigate through the menus.

Step 1 - After the start-up countdown is complete the first screen displayed is the "Startup Delay" screen. Move Joystick. Scroll down to "Details" then press "ENTER".

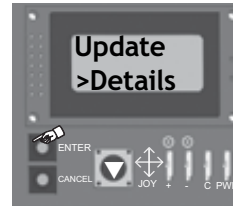

Step 2 - Scroll down to "Econ" and press "ENTER".

Step 3 - "Setup and Service" will now appear. Press "ENTER".

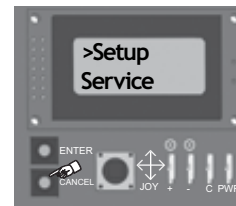
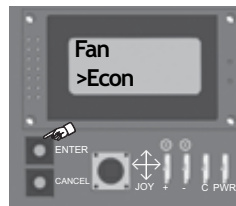

Step 4 - Scroll down to "Econ-MinPos" then press "ENTER".



Step 5 - To adjust the minimum position percentage move the joystick to the right to increase and to left decrease. Then Press "ENTER". **WAIT 5-7 SECONDS FOR VALUE ONSCREEN TO UPDATE!**

Toggle Left to Decrease ◀
Toggle Right to Increase ▶

Screen Will Flash

DOWN ◀ UP ▶



Press the "Cancel" button to exit each menu level. Repeatedly pressing "Cancel" returns the menu to the first "Status, Alarms" screen.

When the "Cancel" button is pressed multiple times to exit each menu level and the screen returns to the first "Status, Alarms" display the next demonstration can begin. In this demonstration the information below steps through the "Commissioning" menu.

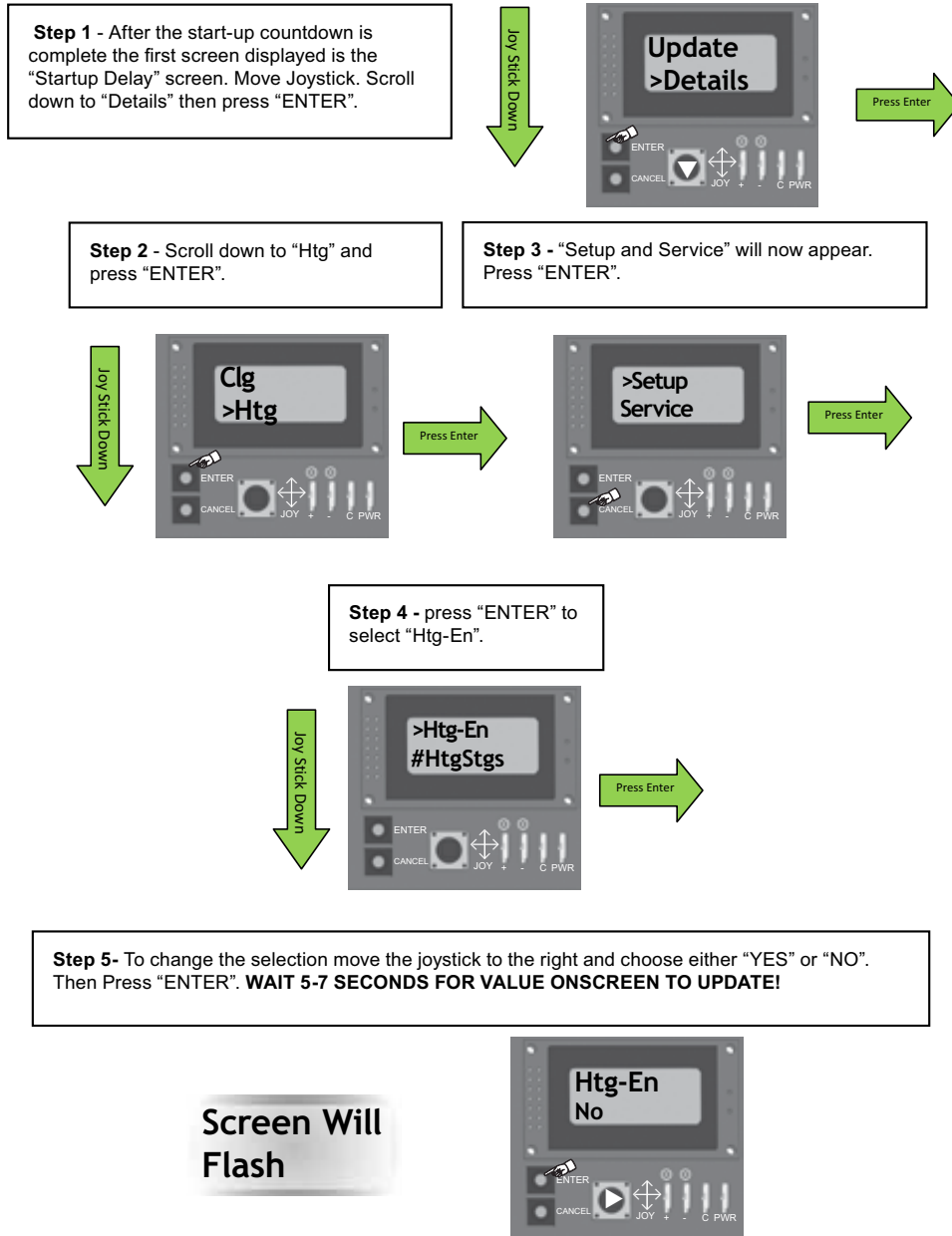

These few pages provide a simple demonstration how to navigate the menu's of the Smart Equipment™ control containing Version 3 firmware. Please utilize this document along with the additional information in the Users Guide and detailed navigation menu to adjust the control to customer preferences or job specifications.

NOTE: IF OPERATING THE EQUIPMENT WITH A THERMOSTAT, THE UCB SETPOINTS AND PARAMETERS SHOULD NOT REQUIRE ALTERATION; HOWEVER, THERE MAY BE THE CASE WHERE MINIMUM OUTSIDE AIR, LEAD-LAG OR OTHER CUSTOM SETTINGS ARE REQUIRED. PLEASE READ THIS DOCUMENT IN DETAIL TO UNDERSTAND THE IMPLICATIONS OF MAKING CHANGES BEFORE PROCEEDING. IT IS STRONGLY RECOMMENDED THAT A BACKUP OF PARAMETER SETTINGS BE SAVED ON A USB DRIVE BEFORE MAKING ANY MAJOR CHANGES TO THE CONTROL!

Start-Up Sheet

START-UP & SERVICE DATA INSTRUCTION

COMMERCIAL PACKAGE UNITS

3.0 To 40.0 TONS

START-UP CHECKLIST

Date: _____

Job Name: _____

Customer Name: _____

Address: _____

City: _____ State: _____ Zip: _____

Model Number: _____ Serial Number: _____

Qualified Start-up Technician: _____ Signature: _____

HVAC Contractor: _____ Phone: _____

Address: _____

Contractor's E-mail Address: _____

Electrical Contractor: _____ Phone: _____

Distributor Name: _____ Phone: _____

WARRANTY STATEMENT

Johnson Controls/UPG is confident that this equipment will operate to the owner's satisfaction if the proper procedures are followed and checks are made at initial start-up. This confidence is supported by the 30 day dealer protection coverage portion of our standard warranty policy which states that Johnson Controls/UPG will cover parts and labor on new equipment start-up failures that are caused by a defect in factory workmanship or material, for a period of 30 days from installation. Refer to current standard warranty policy and warranty manual found on UPGnet for details.

In the event that communication with Johnson Controls/UPG is required regarding technical and/or warranty concerns, all parties to the discussion should have a copy of the equipment start-up sheet for reference. A copy of the original start-up sheet should be filed with the Technical Services Department.

The packaged unit is available in constant or variable air volume versions with a large variety of custom options and accessories available. Therefore, some variation in the startup procedure will exist depending upon the products capacity, control system, options and accessories installed.

This start-up sheet covers all startup check points common to all package equipment. In addition it covers essential startup check points for a number of common installation options. Depending upon the particular unit being started not all sections of this start-up sheet will apply. Complete those sections applicable and use the notes section to record any additional information pertinent to your particular installation.

Warranty claims are to be made through the distributor from whom the equipment was purchased.

EQUIPMENT STARTUP

Use the local LCD or Mobile Access Portal (MAP) Gateway to complete the start-up.

A copy of the completed start-up sheet should be kept on file by the distributor providing the equipment and a copy sent to

Johnson Controls/UPG
Technical Services Department
5005 York Drive
Norman, OK 73069

SAFETY WARNINGS

The inspections and recording of data outlined in this procedure are required for start-up of Johnson Controls/UPG's packaged products. Industry recognized safety standards and practices must be observed at all times. General industry knowledge and experience are required to assure technician safety. It is the responsibility of the technician to assess all potential dangers and take all steps warranted to perform the work in a safe manner. By addressing those potential dangers, prior to beginning any work, the technician can perform the work in a safe manner with minimal risk of injury.

 WARNING
Lethal voltages are present during some start-up checks. Extreme caution must be used at all times.

 WARNING
Moving parts may be exposed during some startup checks. Extreme caution must be used at all times.

NOTE: Read and review this entire document before beginning any of the startup procedures.

DESIGN APPLICATION INFORMATION

This information will be available from the specifying engineer who selected the equipment. If the system is a VAV system the CFM will be the airflow when the remote VAV boxes are in the

full open position and the frequency drive is operating at 60 HZ. **Do not proceed with the equipment start-up without the design CFM information.**

Design Supply Air CFM: _____ Design Return Air CFM: _____

Design Outdoor Air CFM At Minimum Position: _____

Total External Static Pressure: _____

Supply Static Pressure: _____

Return Static Pressure: _____

Design Building Static Pressure: _____

Outside Air Dilution: Economizer Position Percentage: _____ CFM: _____

Supply Gas Pressure After Regulator W/o Heat Active _____ Inches _____

ADDITIONAL APPLICATION NOTES FROM SPECIFYING ENGINEER:

1034349-UCL-E-0817

REFERENCE

General Inspection	Completed	See Notes
Unit inspected for shipping, storage, or rigging damage	<input type="checkbox"/>	<input type="checkbox"/>
Unit installed with proper clearances	<input type="checkbox"/>	<input type="checkbox"/>
Unit installed within slope limitations	<input type="checkbox"/>	<input type="checkbox"/>
Refrigeration system checked for gross leaks (presence of oil)	<input type="checkbox"/>	<input type="checkbox"/>
Terminal screws and wiring connections checked for tightness	<input type="checkbox"/>	<input type="checkbox"/>
Filters installed correctly and clean	<input type="checkbox"/>	<input type="checkbox"/>
Economizer hoods installed in operating position	<input type="checkbox"/>	<input type="checkbox"/>
Condensate drain trapped properly, refer to Installation Manual	<input type="checkbox"/>	<input type="checkbox"/>
Economizer damper linkage tight	<input type="checkbox"/>	<input type="checkbox"/>
Gas Heat vent hood installed	<input type="checkbox"/>	<input type="checkbox"/>
All field wiring (power and control) complete	<input type="checkbox"/>	<input type="checkbox"/>

Air Moving Inspection	Completed	See Notes
Alignment of drive components	<input type="checkbox"/>	<input type="checkbox"/>
Belt tension adjusted properly	<input type="checkbox"/>	<input type="checkbox"/>
Blower pulleys tight on shaft, bearing set screws tight, wheel tight to shaft	<input type="checkbox"/>	<input type="checkbox"/>
Pressure switch or transducer tubing installed properly	<input type="checkbox"/>	<input type="checkbox"/>

Exhaust Inspection	Powered <input type="checkbox"/>	Barometric Relief <input type="checkbox"/>	Completed	See Notes
Check hub for tightness			<input type="checkbox"/>	<input type="checkbox"/>
Check fan blade for clearance			<input type="checkbox"/>	<input type="checkbox"/>
Check for proper rotation			<input type="checkbox"/>	<input type="checkbox"/>
Check for proper mounting (screen faces towards unit)			<input type="checkbox"/>	<input type="checkbox"/>
Prove operation by increasing minimum setting on economizer			<input type="checkbox"/>	<input type="checkbox"/>

Economizer Inspection	Standard <input type="checkbox"/>	BAS <input type="checkbox"/>	Completed	See Notes
CO ₂ sensor installed	Yes <input type="checkbox"/>	No <input type="checkbox"/>	<input type="checkbox"/>	<input type="checkbox"/>
Check economizer setting (Reference Smart Equipment™ Control Board LCD menu location)			<input type="checkbox"/>	<input type="checkbox"/>
Prove economizer open/close through Smart Equipment™ Board Setting			<input type="checkbox"/>	<input type="checkbox"/>

Reheat Mode	Normal <input type="checkbox"/>	or Alternate <input type="checkbox"/>	Not Applicable <input type="checkbox"/>
Humidity Sensor (2SH0401) _____			

Operating Measurements - Air Flow

Fan operates with proper rotation (All VFD equipped units with the optional Manual Bypass must be phased for correct blower rotation with the Bypass switch set in the LINE position) ID Fans Exh. Fans Cond. Fans

Pressure drop across dry evaporator coil (At maximum design CFM) ¹	IWC
External Static Pressure	IWC
Return Static Pressure	IWC
Supply Static Pressure	IWC
Supply Air CFM Using Dry Coil Chart	CFM
Final Adjusted Supply Air CFM ²	CFM

1. Consult the proper airflow to pressure drop table to obtain the actual airflow at the measured pressure differential.
2. Was a motor pulley adjustment or change required to obtain the correct airflow?
 Was it necessary to increase or decrease the airflow to meet the design conditions?
 If the motor pulley size was changed, measure the outside diameters of the motor and blower pulleys and record those diameters here;

Blower Motor HP _____ FLA _____ RPM _____

Pulley Pitch Diameter _____ Turns Out _____ Final Turns Out _____

Blower Pulley Pitch Diameter _____ Fixed Sheave _____

ELECTRICAL DATA

T1 - T2 _____ Volts T2 - T3 _____ Volts

Control Voltage _____ Volts T1 - T3 _____ Volts

Device	Nameplate	Measured List All Three Amperages
Supply Fan Motor ^{1, 2}	AMPS	AMPS
Exhaust Motor (Dampers 100%)	AMPS	AMPS
Condenser Fan #1	AMPS	AMPS
Condenser Fan #2 (if equipped)	AMPS	AMPS
Condenser Fan #3 (if equipped)	AMPS	AMPS
Condenser Fan #4 (if equipped)	AMPS	AMPS
Compressor #1	AMPS	AMPS
Compressor #2 (if equipped)	AMPS	AMPS
Compressor #3 (if equipped)	AMPS	AMPS
Compressor #4 (if equipped)	AMPS	AMPS

1. VAV units with heat section - simulate heat call to drive VAV boxes and VFD/IGV to maximum design airflow position.
2. VAV units without heat section - VAV boxes must be set to maximum design airflow position.

1034349-UCL-E-0817

OPERATING MEASUREMENTS - COOLING

Stage	Discharge Pressure	Discharge Temp.	Liquid Line Temp. ¹	Subcooling ²	Suction Pressure	Suction Temp.	Superheat
First	#	°	°	°	#	°	°
Second (if equipped)	#	°	°	°	#	°	°
Third (if equipped)	#	°	°	°	#	°	°
Fourth (if equipped)	#	°	°	°	#	°	°
Reheat 1st Stage	#	°	°	°	#	°	°

1. Liquid temperature should be taken before filter/drier.

2. Subtract 10 psi from discharge pressure for estimated liquid line pressure

Outside air temperature	_____	°F db	_____	°F wb	_____	%RH
Return Air Temperature	_____	°F db	_____	°F wb	_____	%RH
Mixed Air Temperature	_____	°F db	_____	°F wb	_____	%RH
Supply Air Temperature	_____	°F db	_____	°F wb	_____	%RH

REFRIGERANT SAFETIES

Action	Completed	See Notes
Prove Compressor Rotation (3 phase only) by gauge pressure	<input type="checkbox"/>	<input type="checkbox"/>
Prove High Pressure Safety, All Systems	<input type="checkbox"/>	<input type="checkbox"/>
Prove Low Pressure Safety, All Systems	<input type="checkbox"/>	<input type="checkbox"/>

OPERATING MEASUREMENTS - GAS HEATINGFuel Type: Natural Gas LP Gas

Action	Completed	See Notes
Check for gas leaks	<input type="checkbox"/>	<input type="checkbox"/>
Prove Ventor Motor Operation	<input type="checkbox"/>	<input type="checkbox"/>
Prove Primary Safety Operation	<input type="checkbox"/>	<input type="checkbox"/>
Prove Auxiliary Safety Operation	<input type="checkbox"/>	<input type="checkbox"/>
Prove Rollout Switch Operation	<input type="checkbox"/>	<input type="checkbox"/>
Prove Smoke Detector Operation	<input type="checkbox"/>	<input type="checkbox"/>
Manifold Pressure	Stage 1	IWC <input type="checkbox"/>
	Stage 2 (If Equipped)	IWC <input type="checkbox"/>
	Stage 3 (If Equipped)	IWC <input type="checkbox"/>
Supply gas pressure at full fire	IWC	<input type="checkbox"/>
Check temperature rise ¹	<input type="checkbox"/> measured at full fire	°F <input type="checkbox"/>

1. Input X Eff. (BTU output)
1.08 X Temp. Rise

OPERATIONAL MEASUREMENTS - STAGING CONTROLS

Verify Proper Operation of Heating/Cooling Staging Controls	
Create a cooling demand at the Thermostat, BAS System or Smart Equipment™ Verify that cooling/economizer stages are energized.	<input type="checkbox"/>
Create a heating demand at the Thermostat, BAS System or Smart Equipment™ Verify that heating stages are energized.	<input type="checkbox"/>
Verify Proper Operation of the Variable Frequency Drive (If Required)	
Verify that motor speed modulates with duct pressure change.	<input type="checkbox"/>

FINAL - INSPECTION

Verify that all operational control set points have been set to desired value Scroll through all setpoints and change as may be necessary to suit the occupant requirements.	<input type="checkbox"/>
Verify that all option parameters are correct Scroll through all option parameters and ensure that all installed options are enabled in the software and all others are disabled in the software. (Factory software settings should match the installed options)	<input type="checkbox"/>
Verify that all access panels have been closed and secured	<input type="checkbox"/>
Save a backup file from the unit control board onto a USB flash drive.	<input type="checkbox"/>

OBSERVED PRODUCT DEFICIENCIES & CONCERNS:
