

INSTALLATION INSTRUCTION

BASE ACCESSORY MODELS, 1BS0450, 1BS0451, 1BS0452

Supersedes: 550.13-N10.4V (1285)

550.13-N10.4U (299)

035-16632

FOR 5 THRU 15 TON SPLIT-SYSTEM EVAPORATOR BLOWERS, & & 7-1/2 & 10 TON SPLIT-SYSTEM HEAT PUMPS INDOOR UNITS 1BS0450 - 5 TON UNITS 1BS0451 - 7-1/2 & 10 TON UNITS 1BS0452 - 15 TON UNITS

GENERAL

This instruction covers the field assembly and installation of these base accessories.

These bases are finished to match the exterior of the indoor units and are designed to raise vertical units 20" (5, 7-1/2 & 10 ton units) and 24" (15 ton units) above the floor. Refer to Figure 1 for as typical installation.

An access opening can be cut through the back panel of either base accessory to accommodate outdoor air ductwork. The interior of the base section will have to be insulated by the installer for such applications.

INSTALLATION

BASE ACCESSORIES 1BS 0450 AND 1BS0451

Assemble this accessory per Figure 2 and the following instructions.

1. Position the side panels so that the flanges with the retainer nuts are facing front.
2. Position the end flanges of the back panel inside the back flanges of the side panels, and secure them with four 1/4" machine screws and four #10 tapping screws.
3. Position the end flanges of the two support angles inside the front flanges of the two side panels and secure them with eight #10 tapping screws.

NOTE: Recheck Figure 2 for the proper orientation of these two support angles.

4. Tip the indoor unit over onto its back, remove its bottom panel and save both the panel and the screws.
5. Secure the partially assembled base to the bottom of the unit with eight #10 tapping screws.
6. Attach one #10 speed nut to the center hole of the bottom flange on the two side panels of the base accessory.
7. Secure the bottom panel removed in step 4 to the bottom of the base using the same screws.

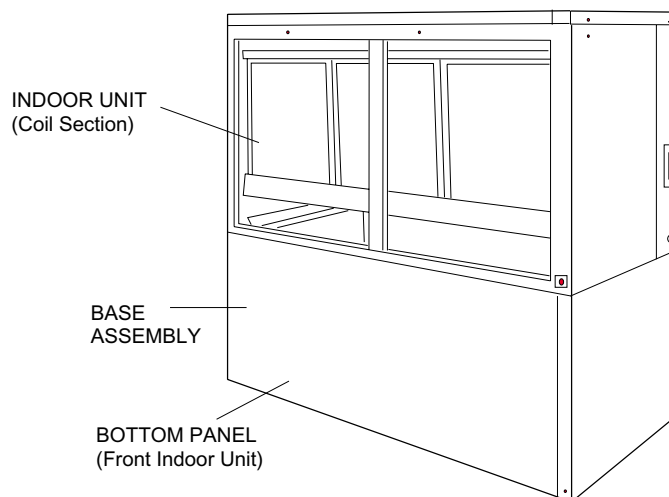

FIG. 1 - Base Accessory Installed (15 Ton Unit)

8. Secure the front panel to the front of the base with four 1/4" machine screws.
9. Return the unit with base to the vertical position.

BASE ACCESSORY 1BS0452 FOR 15 TON UNITS

Assemble this accessory per Figure 3 and the following instructions.

1. Secure the four support angles to the inside corners of the two side panels with sixteen 3/8" machine screws.
2. Attach six retainer nuts to each side panel (to the front, back and bottom flanges).
3. Secure the back panel to the back flanges of the two side panels with four 1/4" machine screws.
4. Tip the indoor unit over onto its back. Remove the bottom panel and save the panel and the screws.
6. Secure the bottom panel, removed in Step 4, to the bottom of the base using the same screws.
7. Secure the front panel to the front of the base with four 1/4" machine screws.
8. Return the unit with base to the vertical position.

Installer should pay particular attention to the words: *NOTE*, *CAUTION* and *WARNING*. *Notes* are intended to clarify or make the installation easier. *Cautions* are given to prevent equipment damage. *Warnings* are given to alert installer that personal injury and/or equipment damage may result if installation procedure is not handled properly.

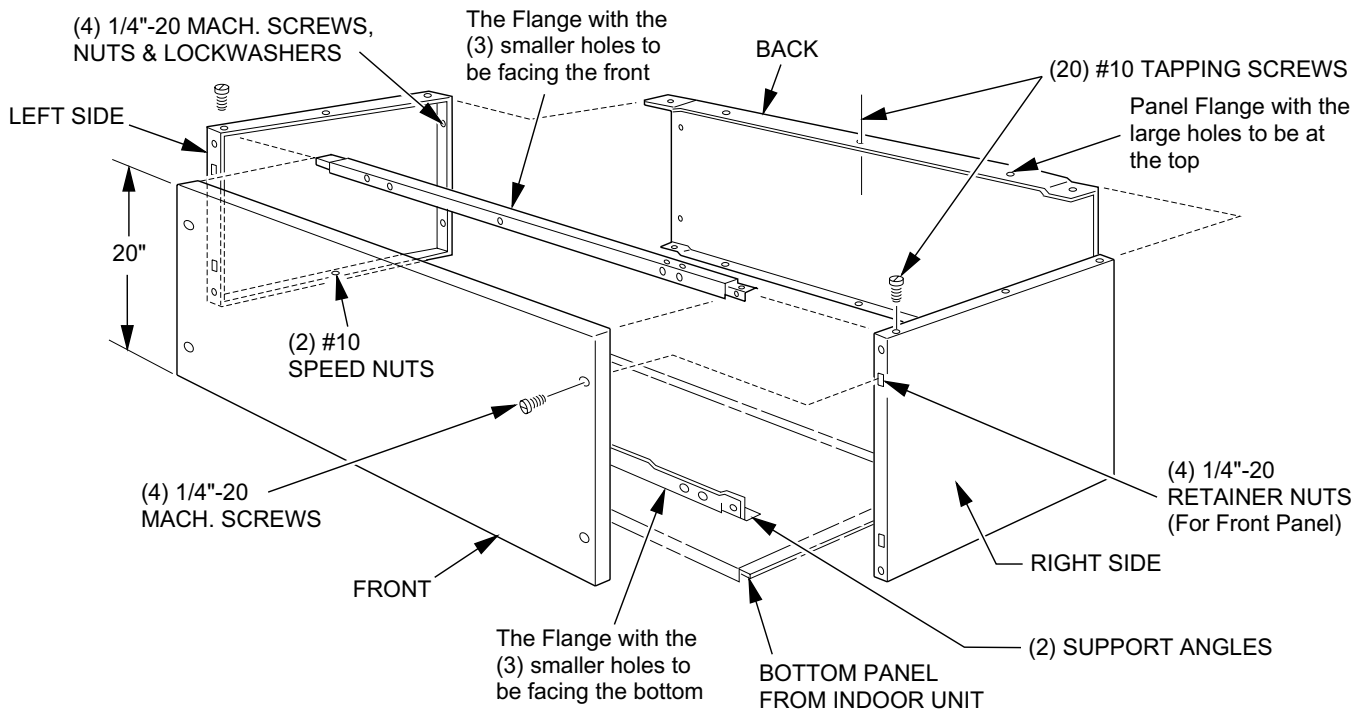

FIG. 2 - Base Accessory for 5 thru 10 Ton Units

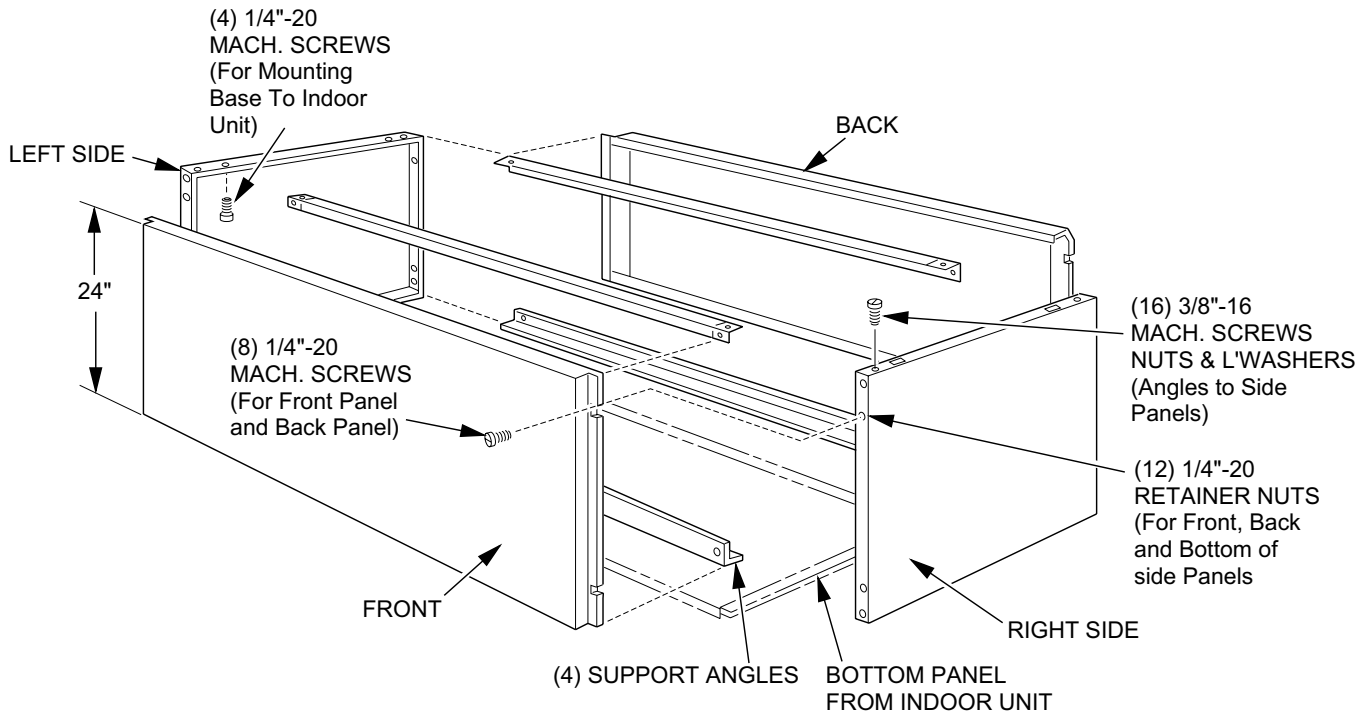

FIG. 3 - Base Assembly for 15 Ton Unit

Supersedes 550.13-N10.4V (1285)
 Subject to change without notice. Printed in U.S.A.
 Copyright © by Unitary Products Group 1996. All rights reserved.

Code: SBY, C, L, F

530.13-N10.4U

Unitary Products Group 5005 York Drive Norman Oklahoma 73069