



An ACS Brand

Air Conditioner Product Manual

Vertical Wall-Mount Air Conditioners with Front Control Box Panel

Installation & Operation Manual

11 EER Vertical Wall-Mount Air Conditioners

MODELS:

EAA1020A-EAA1060A

EGA1072A



IMPORTANT

This manual may include information for options and features which may not be included on the unit being installed. Refer to the unit data label or Model Identification to determine which features and options this unit is equipped with.

INSTALLER: Affix the instructions on the inside of the building adjacent to the thermostat.
END USER: Retain this manual for future reference.

Manufactured By:

Eubank, An AirX Climate Solutions Brand

P.O. Box 400 • Cordele, Georgia 31010 • 156 Seedling Drive • Cordele, Georgia 31015
(229) 273-3636 • Fax (229) 273-5154

E-mail: eubanksales@airxcs.com • Internet: www.EubankWallMount.com

The most current version of this manual can be found at www.EubankWallMount.com.

How To Use This Manual

This manual is intended to be a guide to the Eubank Wall Mount family of vertical air conditioners. It contains installation, troubleshooting, maintenance, warranty, and application information. The information contained in this manual is to be used by the installer as a guide only. This manual does not supersede or circumvent any applicable national or local codes.

If you are installing the Eubank unit, first read Chapter 1 and scan the entire manual before beginning the installation as described in Chapter 2. Chapter 1 contains general, descriptive information and provides an overview which can speed up the installation process and simplify troubleshooting.

If a malfunction occurs, follow this troubleshooting sequence:

1. Make sure you understand how the Eubank unit works (Chapters 1 & 3).
2. Identify and correct installation errors (Chapter 2).
3. Refer to the troubleshooting information in Chapter 4.

If you are still unable to correct the problem, contact the Factory at 1-800-841-7854 for additional assistance.

Please read the following “Important Safety Precautions” before beginning any work.

Important Safety Precautions

1. USE CARE when LIFTING or TRANSPORTING equipment.
2. TRANSPORT the UNIT UPRIGHT. Laying it down on its side may cause oil to leave the compressor and breakage or damage to other components.
3. TURN ELECTRICAL POWER OFF AT THE breaker or fuse box BEFORE installing or working on the equipment. LINE VOLTAGES ARE HAZARDOUS or LETHAL.
4. OBSERVE and COMPLY with ALL applicable PLUMBING, ELECTRICAL, and BUILDING CODES and ordinances.
5. SERVICE may be performed ONLY by QUALIFIED and EXPERIENCED PERSONS.
 - * Wear safety goggles when servicing the refrigeration circuit
 - * Beware of hot surfaces on refrigerant circuit components
 - * Beware of sharp edges on sheet metal components
 - * Use care when recovering or adding refrigerant
6. Use COMMON SENSE - BE SAFETY-CONSCIOUS

This is the safety alert symbol . When you see this symbol on the Eubank unit and in the instruction manuals be alert to the potential for personal injury. Understand the signal word DANGER, WARNING, CAUTION and IMPORTANT. These words are used to identify levels of the seriousness of the hazard.

 **DANGER** Failure to comply will result in death or severe personal injury and/or property damage.

 **WARNING** Failure to comply could result in death or severe personal injury and/or property damage.

 **CAUTION** Failure to comply could result in minor personal injury and/or property damage.

 **IMPORTANT** Used to point out helpful suggestions that will result in improved installation, reliability or operation.

AS PART OF THE EUBANK CONTINUOUS IMPROVEMENT PROGRAM, SPECIFICATIONS ARE SUBJECT TO CHANGE WITHOUT NOTICE.

© 05/2023 Eubank, An AirX Climate Solutions Brand

 **WARNING**

- If the information in these instructions are not followed exactly, a fire may result causing property damage, personal injury or loss of life.
- Read all instructions carefully prior to beginning the installation. Do not begin installation if you do not understand any of the instructions.
- Improper installation, adjustment, alteration, service or maintenance can cause property damage, personal injury or loss of life.
- Installation and service must be performed by a qualified installer or service agency in accordance with these instructions and in compliance with all codes and requirements of authorities having jurisdiction.

INSTALLER: Affix the instructions on the inside of the building adjacent to the thermostat.

END USER: Retain these instructions for future reference.

Table of Contents

Chapter 1 Eubank Wall Mount Air Conditioner Description & Specifications

1.1	General Description	5
1.2	Model Identification	6
1.3	Serial Number Date Code	6
1.4	Air Flow, Weights and Filter Sizes.....	7
1.5	General Operation	7
1.6	Optional Controls and Packages	8
1.7	Electrical Operation	10

Chapter 2 Electronic Control Board

2.1	Introduction	16
2.2	Installation and Replacement	17
2.3	PCB Details and Information	17
2.4	Operation.....	21
2.5	Sequence of Operation	21

Chapter 3 Installation

3.1	Equipment Inspection.....	33
3.2	Installation Requirements.....	33
3.3	Installation Materials	35
3.4	Porting and Duct Work	36
3.5	Fresh Air Hood Installation	37
3.6	Bracket Installation	38
3.7	Mounting the Unit	38
3.8	Electrical Connections	39

Chapter 4 Start-Up

4.1	Check-Out of Cooling Cycle	43
4.2	Check-Out of Heating Cycle.....	43

Table of Contents

Chapter 5 Troubleshooting

5.1	Overview	44
5.2	Failure Symptoms Guide.....	45
5.3	Compressor Troubleshooting	45
5.4	Control Board Diagnosis.....	46

Chapter 6 Maintenance

6.1	Scheduled Maintenance	47
-----	-----------------------------	----

Chapter 7 Warranty

7.1	Eubank Limited Product Warranty.....	48
-----	--------------------------------------	----

Chapter 8 Start-Up Checklist

8.1	Start-Up & Commissioning Form.....	49
-----	------------------------------------	----

Appendix A

	Installation Instructions for Field Installed Electric Heaters	53
--	--	----

Illustrations

Figure 1a.	Typical Electrical Schematic - Model EAA.....	11
Figure 1b.	Typical Electrical Schematic - Model EAA.....	12
Figure 1c.	Typical Electrical Schematic - Model EAA (Alternate Construction).....	13
Figure 1d.	Typical Electrical Schematic - Model EAA (Alternate Construction).....	14
Figure 1e.	Typical Electrical Schematic - Model EGA (Alternate Construction).....	15
Figure 2.	Enthalpy Sensor Temperature Control Points	26
Figure 3.	Dry Bulb Sensor.....	27
Figure 4.	Fresh Air Hood Damper, Models 1024-1072.....	37
Figure 5.	Wall Mounting Detail.....	38
Figure 6a.	Humidistat Wiring Details.....	41
Figure 6b.	Thermostat Connection Diagram	41
Figure 6c.	CommStat™ 3 HVAC Controller Wiring Detail.....	42

Tables

Table 1	CFM @ External Static Pressure	7
Table 2	Return Air Filter Sizes	7
Table 3	Shipping Weights	7
Table 4	Ambient Temperature Operating Range	7
Table 5	Refrigerant Charge.....	7
Table 6	Minimum Clearances.....	34
Table 7	Voltage Limitations.....	34
Table 8	Maximum Static Pressure	37

Chapter 1 Description & Specifications

1.1 General Description

The Eubank EAA and EGA are a series of vertical wall-mounted air conditioning systems that provide heating, cooling, and ventilation for electronic equipment shelters, process control centers, and other applications with high internal heat gains. The series includes multiple sizes and nominal cooling capacities from 20,000 to 72,000 BTUH. Resistance heating elements are available in various wattages.

EAA modes are available with cooling capacities of 20,000 to 60,000 BTUH and EER's of 11.00 to 11.50. EGA models have 72,000 BTUH (6 ton) capacity and are 10 EER. The Eubank Product Data Sheets have detailed information on the capacities and efficiencies for each model.

See Appendix A for instructions on field installation of electric heat.

Eubank air conditioners feature an exclusive electronic control board. The control board consolidates several of the electrical components and improves the air conditioner's reliability. The control board replaces the blower relay, the lockout relay, the compressor time delay and the timed low pressure bypass. In addition, the control board has LED's to indicate operating status and fault conditions to assist the service technician. A complete description of functions of the control board is in Section 1.6.

All models are designed for easy installation and service. Major components are accessible for service beneath external panels.

All units have internal disconnects (optional on 380V and 575V). Follow local codes for external disconnect requirements.

Eubank wall mount air conditioners have a 0-15% manual outside air damper as standard equipment. All models are available with an optional factory installed economizer for 100% free cooling with outside air.

1.2 Model Identification

The model identification number is found on the data sticker. Rating plate located on side panel.

Example	E	A	A	1	0	3	6	A	A	0	5	0	C	R	+	+	+	1	D	A	+	A	2	1	+	+	+	+	+	+
Position	1	2	3	4	5	6	7	8	9	10	11	12	13	14	15	16	17	18	19	20	21	22	23	24	25	26	27	28	29	30

1	Unit Designation/Family	E = Eubank Wall Mount
2	Energy Efficiency Ratio (EER)	A = 11 G = 10
3	Refrigerant Type	A = R-410a
4	Compressor Type/Quantity	1 = Single
5	Unit Capacity/Nominal Cooling (BTUH)	020 = 20,000 042 = 42,000
6		024 = 24,000 048 = 48,000
7		030 = 30,000 060 = 60,000 036 = 36,000 072 = 72,000
8	System Type	A = Air Conditioner
9	Power Supply (Volts-Phase-Hz)	A = 208/230-1-60 C = 208/230-3-60 D = 460-3-60
10	Heat Designation @ Rated Voltage KW = Kilowatt	000 = No Heat 080 = 8KW
11		022 = 2.2KW 090 = 9KW
12		036 = 3.6KW 100 = 10KW 040 = 4KW 120 = 12KW 050 = 5KW 150 = 15KW 060 = 6KW
13	Ventilation Configuration	A = Solid Front Door C = Economizer D = Motorized Damper w/Pressure Relief E = Motorized Damper w/Pressure Relief & Independent Motorized Damper Control F = No Free Cooling, 100% Emergency Ventilation Only w/Independent Control N = Barometric Damper w/15% OSA Y = Manual Damper w/No Pressure Relief Z = Manual Damper w/Pressure Relief + = None \$ = Special
14	Dehumidification	G = Hot Gas Reheat R = Electric Reheat T = Electric Reheat w/Humidity Control + = None
15	Controls	A = Power Fail Alarm w/Additional Lockouts C = 24V EMS Relay Kit D = 24V EMS Relay Kit w/Factory Installed T-Stat E = Factory Installed T-Stat + = None
16	Operating Condition	A = Evaporator Freeze Sensor (EFS) C = EFS w/Hot Gas Bypass N = Hard Start P = Hard Start w/Low Ambient & CCH Q = Hard Start w/Low Ambient & Fan Cycle Control (FCC) R = Crank Case Heater (CCH) T = Hard Start w/EFS U = Hard Start w/Hot Gas Bypass V = Hard Start w/Low Ambient & CCH & EFS W = Low Ambient w/CCH X = Hot Gas Bypass Y = Low Ambient w/CCH & FCC Z = Low Ambient w/CCH & EFS 1 = Low Ambient w/FCC 2 = Low Ambient w/FCC & EFS 3 = CCH w/Hot Gas Bypass + = None

17	Indoor Air Quality Features	D = Dry Bulb Sensor E = Dry Bulb Sensor w/Dirty Filter G = Dirty Filter Sensor + = None
18	Air Flow	1 = Top Supply/Bottom Return
19	Compressor Location	D = Left Hand - All 3 1/2 to 5 ton units E = Right Hand - All 1 1/2 to 3 ton units
20	Filter Option	A = 2" Pleated (MERV 8) C = 2" Charcoal D = MERV 11 High Filtration Package E = MERV 13 High Filtration Package F = Filter Access Through Return Air Grille W = Aluminum Washable + = None
21	Corrosion Protection	A = Condenser Coil Only C = Evaporator Coil Only D = Both Coils Condenser & Evaporator E = All Coils Cond/Evap/Reheat F = Coat All K = Coastal Package + = None \$ = Special
22	Engineering	A2
23	Revision Level	
24	Cabinet Color	1 = Beige (Standard Eubank) 2 = Gray 3 = Carlsbad Canyon 4 = White 5 = Stainless Steel Exterior 6 = Dark Bronze 7 = .050 Aluminum Stucco 8 = Mesa Tan 9 = Pebble Gray A = Stainless Steel - Unit \$ = Custom Color (Powder Coat)
25	Sound Attenuation	2 = Compressor Blanket + = None
26	Security Option	A = Lockable Access Plate/Tamper Proof + = None
27	Fastener/Drain Pan Option	A = Stainless Steel Fasteners C = Stainless Steel Drain Pan D = Stainless Steel Fasteners & Drain Pan + = None
28	Unused	+ = None \$ = Special
29	Unused	+ = None \$ = Special
30	Special Variation	+ = None \$ = Special Configuration Not Covered by Model Nomenclature

Note: Not all options are available with all configurations. Contact your Eubank sales representative for configuration details and feature compatibility.

1.3 Serial Number Date Code

20 = 2020	01 = January	05 = May	09 = September
21 = 2021	02 = February	06 = June	10 = October
22 = 2022	03 = March	07 = July	11 = November
23 = 2023	04 = April	08 = August	12 = December

1.4 Air Flow, Weights and Filter Sizes

Complete electrical and performance specifications and dimensional drawings are in the Eubank Wall Mount Air Conditioner Product Data Sheets.

Note: Follow local codes and standards when designing duct runs to deliver the required airflow. Minimize noise and excessive pressure drops caused by duct aspect ratio changes, bends, dampers and outlet grilles in duct runs.

MODEL	0.10	0.15	0.20	0.25	0.30	0.40	0.50
EAA1020	800	785	770	725	680	600	
EAA1024	800	785	770	725	680	600	500
EAA1030	1200	1150	1100	1050	1000	900	800
EAA1036	1290	1230	1170	1115	1060	1000	920
EAA1042	1500	1430	1360	1295	1230	1160	1070
EAA1060	1900	1850	1800	1700	1600	1500	1350
EGA1072	1900	1850	1800	1700	1600	1500	1350

Values in bold are the minimum air flow.
 Air flow ratings of 208-230 volt units are at 230v. Air flow ratings of 460 volt units are at 460 volts. Operation of units at a voltage different from the rating point will affect air flow.

Table 1. CFM @ External Static Pressure (Wet Coil) (IWG)

MODEL	INCHES	MILLIMETERS	PART NUMBER	FILTERS PER UNIT	MERV RATING
EAA1020/1024	30 x 16 x 2	762 x 406 x 52	80138	1	8
EAA1030/1036/1042/1048	36½ x 22 x 2	927 x 559 x 52	80162	1	8
EAA1060	18 x 24 x 2	457 x 610 x 52	81257	2	8
EGA1072	18 x 30 x 2	457 x 762 x 52	93184	2	8

Table 2. Return Air Filter Sizes

MODEL	LBS	KG
Non-Economizer		
EAA1020/1024	355	160
EAA1030/1036/1042	535	245
EAA1048/1060	625	284
EGA1072	680	309
With Economizer		
EAA1020/1024	375	170
EAA1030/1036/1042	590	268
EAA1048/1060	640	291
EGA1072	740	336

Table 3. Shipping Weights for Eubank Wall Mount AC Units

1.5 General Operation

Model	Ventilation Configuration	Temperature Range
Non-Economizer	Standard ("N"), Desert Duty ("ND")	0°F – 131°F (-18°C – 55°C)
With Economizer	Standard ("CE"), Desert Duty ("CD")	-40°F – 131°F (-40°C – 55°C)

Table 4. Ambient Temperature Operating Range

Model	EAA1018A	EAA1020A	EAA1024A	EAA1030A	EAA1036A	EAA1042A	EAA1048A	EAA1060A	EGA1072A
	A	A	A C D Z	A C D Z	A C D Z	A C D Z	A C D Z	A C D Z	A C D Z
w/o Hot Gas Reheat	65	85	85	105	105	123	128	125	150 160
w/Hot Gas Reheat	N/A	N/A	N/A	N/A	N/A	N/A	N/A	N/A	N/A N/A

Table 5. Refrigerant Charge (R410A, Ounces)

Refrigerant Cycle (Cooling Mode)

Eubank air conditioners use R-410A refrigerant in a conventional vapor-compression refrigeration cycle to transfer heat from air in an enclosed space to the outside. A double blower assembly blows indoor air across the evaporator. Cold liquid refrigerant passing through the evaporator is boiled into gas by heat removed from the air. The warmed refrigerant gas enters the compressor where its temperature and pressure are increased. The hot refrigerant gas condenses to liquid as heat is transferred to outdoor air drawn across the condenser by the condenser fan. Liquid refrigerant is metered into the evaporator to repeat the cycle.

Heating Mode

A wall-mounted thermostat controls the heating cycle of models which incorporate resistance heating elements. On a call for heat, the thermostat closes the heat relay to energize the indoor fan and the resistance elements. Except on units with the optional dehumidification kit, the compressor is locked out during the heating cycle. Please see Appendix A for instructions on field installing electric heaters.

Economizer Operation

The economizer is a regulated damper system with controls. The damper regulates the circulation of outside air into the enclosure (when the outdoor air conditions are suitable) to reduce the need for mechanical cooling, save energy, and extend compressor life.

Depending upon the options selected, the damper responds to the enthalpy of the outdoor air. On a call for cooling from a space thermostat, it operates as follows:

When the enthalpy of the outdoor air is below the set point, the outdoor air damper is proportionally open (and return air damper is proportionally closed) to maintain between 50°F and 56°F (10°C to 13°C) at the mixed/discharge air sensor. Integral pressure relief allows the indoor air to exit the shelter through the air conditioner.

When the enthalpy of the outdoor air is above the set point, the outdoor air damper closes to its minimum position. A call for cooling from the space thermostat brings on mechanical cooling.

A built-in adjustable minimum position potentiometer controls the amount of outdoor air admitted to meet minimum ventilation requirements.

1.6 Optional Controls & Packages

Hard Start Kit

Used on single phase equipment to give the compressor higher starting torque under low voltage conditions. Generally not recommended on units with scroll compressors.

Protective Coating Packages

Typically only the non-economizer units are used in corrosive environments, but the air conditioners with an economizer is also available with corrosion protection. Two corrosion protection packages are offered- one for the condenser section (the Coastal Environmental package) and the other for the entire unit (the Coat-All Package).

The Coastal Environmental Package includes:

- Corrosion resistant fasteners
- Sealed or partially sealed condenser fan motor
- Protective coating applied to all exposed internal copper and metal in the condenser section
- Protective coating on the condenser coil (Luvata Insitu®) contains ES2 (embedded stainless steel pigment) technology.

The Coat all Package includes all of the above, plus:

- Protective coating on the evaporator coil (Luvata Insitu®) contains ES2 (embedded stainless steel pigment) technology
- Protective coating on exterior and interior components and sheet metal. (Note: the internal sheet metal which is insulated, bottom outside panel, and the internal control box are not coated)

Hot Gas Bypass (Non-Economizer Models Only)

Used in specialty applications; i.e., Magnetic Resonance Imaging (MRI) buildings, to prevent magnetic voltage disturbance caused by compressor cycling. Two hot gas bypass option packages are available to allow operation to 20°F (-7°C) or minus 20°F (-29°C). Please refer to Hot Gas Bypass Application Bulletin for details.

Electric Reheat Dehumidification

A humidity controller allows electric heat and cooling to operate simultaneously. Eubank® air conditioners equipped with the dehumidification option allow the indoor humidity of the controlled environment to be maintained at or below a certain humidity set point. These units do not have the ability to add humidity to the building.

IMPORTANT

The electrical wire and breaker or fuses must be sized for simultaneous operation of the electric heater and the air conditioner. Refer to the data sticker on the unit or the appropriate Air Conditioner Product Data Sheet for the sizing information.

Dehumidification is achieved by operating mechanical cooling in conjunction with electric reheat. The strip heat is sized approximately to the sensible capacity of the total tonnage of the machine (i.e., on a 24,000 BTU unit the strip heat is sized at approximately 20,000 BTU). Because the strip heat is sized to the approximate sensible cooling capacity, only selected models are available.

Operation:

When the humidity rises above the set point on the humidity controller both mechanical cooling and electric reheat operate to temper the air and lower the humidity. If the temperature in the controlled environment rises above the set point of the thermostat and the unit is operating in the dehumidification mode, the call for cooling will override the call for dehumidification and the strip heat is disengaged until the thermostat is satisfied. This assures the environment temperature is maintained as first priority and humidity control is second.

In applications where a shelter has redundant air conditioning units and is controlled by a lead lag controller (CommStat 4, CommStat 3 HVAC Controller), most times the dehumidification option is only necessary on one of the two units. It is possible for one unit to be operating in the cooling mode while the unit with dehumidification is operating at the same time. If the cooling unit does not maintain the shelter temperature set point, the unit with dehumidification will go into the cooling mode. It does not matter whether the unit with dehumidification is the lead or lag unit.

Three Phase Voltage Monitor

Continuously measures the voltage of each of the three phases. The monitor separately senses low and high voltage, voltage unbalance including phase loss and phase reversal. An LED indicator glows when all voltages are acceptable. Automatically resets when voltages and phases are within operating tolerances. Not required on 1Ø units.

Dirty Filter Indicator

A diaphragm type of indicator measures the air pressure on either side of the filter and when the pressure drops below the set point, a red LED is illuminated. The set point is adjustable.

Protective Coil Coatings

Either the condenser or evaporator coil can be coated, however, coating of the evaporator coil is not

common. For harsh conditions, e.g., power plants, paper mills or sites where the unit will be exposed to salt water, the condenser coil should be coated. Note: Cooling capacity may be reduced by up to 5% on units with coated coils.

Thermal Expansion Valve

Available on all Eubank air conditioners. Improves performance in hot ambient temperatures.

High Filtration

Selected units are built with larger blowers/motors for use with higher efficiency filters with MERV ratings of 11, 13 and 14 when tested to ASHRAE 52.2. Units with economizers have a pre-filter on the outside air.

Lockable Disconnect Access Cover Plate

The access plate to the service disconnect switch can be equipped with a lockable cover.

Cold Climate Kit

Controls and components which allow the units to operate in extremely cold temperatures. The kit includes a suction line accumulator, thermal expansion valve (TXV), crankcase heater, hard start kit, and an outdoor thermostat and fan cycle switch. The fan cycle control is standard on all Eubank air conditioners and operates based upon the liquid line pressure. The outside thermostat opens whenever the outside temperature is below 50°F (10°C) and closes when the outside temperature is 50°F (10°C) or higher. Whenever the temperature is below 50°F (10°C), the fan cycle switch is in the circuit; when temperatures are 50°F (10°C) or higher, the fan cycle switch is not in the circuit. The outdoor thermostat is used with a TXV to prevent excessive cycling or “hunting” of the TXV.

Desert Duty

Controls and components which allow the units to operate in very hot ambients (131°F/55°C). Includes a thermal expansion valve, a sealed condenser fan motor, slotted base pan and a sealed control box. A closed loop design on non-economizer units insures that no outside air is introduced into the shelter.

Cabinet Color and Material

Eubank air conditioners are available in three different cabinet colors -the standard beige, white, Mesa Tan and gray. The standard cabinet’s sides, top and front panels are constructed of 20 gauge painted steel. As an option, these panels can be built of 16 gauge steel in beige & gray or .050 stucco aluminum. When the 16 gauge painted steel or the aluminum is used, only the side, top and front panels are 16 gauge or aluminum. Contact your Eubank representative for color chips. The cabinet can also be constructed of type 316 stainless steel. Two stainless steel cabinet constructions are available- the complete cabinet, including most internal sheet metal or only the exterior sheet metal

1.7 Electrical Operation

The compressor and condenser fan are energized with a contactor controlled by a 24 VAC pilot signal.

Some compressors incorporate an internal PTC crankcase heater that functions as long as primary power is available. The heater drives liquid refrigerant from the crankcase and prevents loss of lubrication caused by oil dilution. Power must be applied to the unit for 24 hours before starting the compressor.

The condenser (outside fan) motor is energized by the same contactor. However, the motor is cycled on and off by the low ambient control (see low ambient control 1.6).

The indoor evaporator fan motor is controlled by the fan purge on the electronic control board.

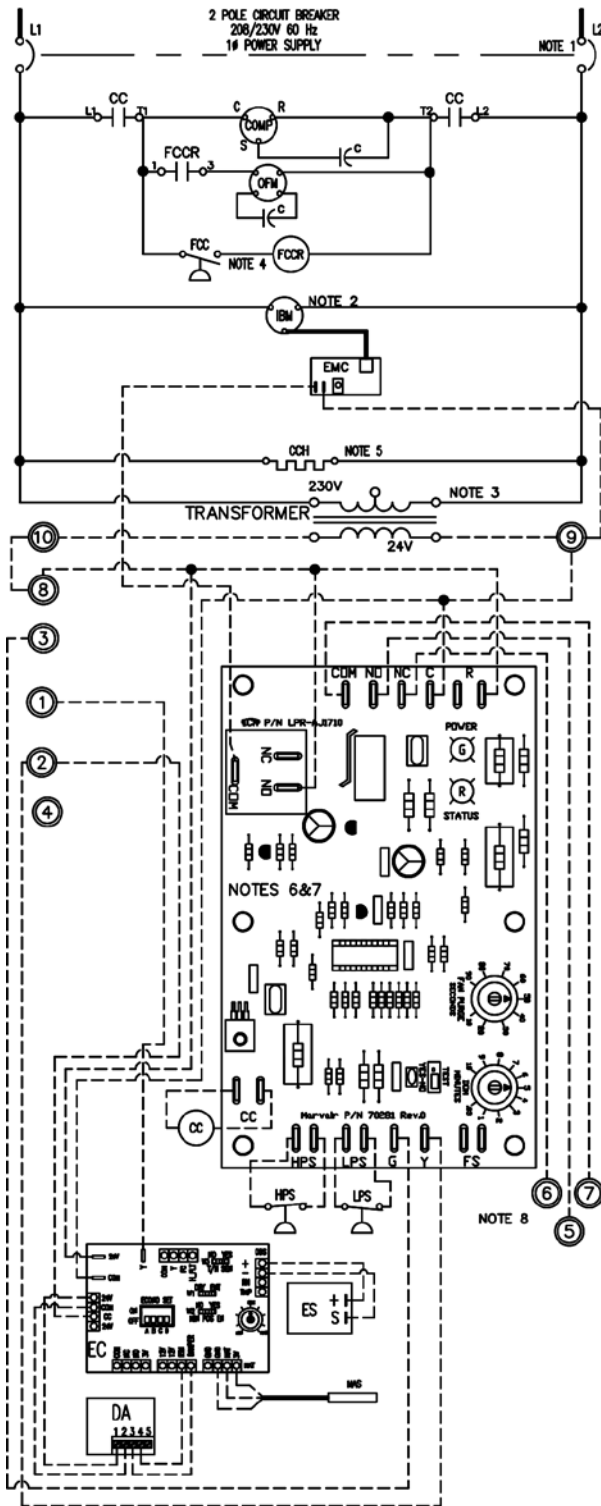

ELECTRICAL LEGEND:

C	CAPACITOR	LPS	LOW PRESSURE SWITCH
CC	COMPRESSOR CONTACTOR	MAS	MIXED AIR SENSOR
CCH	CRANKCASE HEATER	OFM	OUTDOOR FAN MOTOR
COMP	COMPRESSOR	PCB	PRINTED CIRCUIT BOARD
DA	DAMPER ACTUATOR	XFMR	TRANSFORMER
EC	ECONOMIZER CONTROLLER		
EMC	ELECTRONIC MOTOR CONTROL		
ES	ENTHALPY SENSOR		
FCC	FAN CYCLE CONTROL		
FCCR	FAN CYCLE CONTROL RELAY		
HPS	HIGH PRESSURE SWITCH		
IBM	INDOOR BLOWER MOTOR		

VOLTAGE LEGEND

—————	LINE VOLTAGE FACTORY
—————	LINE VOLTAGE FIELD
- - - - -	LOW VOLTAGE FACTORY
- - - - -	LOW VOLTAGE FIELD
- - - - -	ALT. VOLTAGE (FIELD SPEC.)

COLOR CODE

BK - BLACK	O - ORANGE
BL - BLUE	R - RED
BR - BROWN	Y - YELLOW
G - GREEN	WHT - WHITE
BK/RED - BLACK, RED STRIPE	

GENERAL NOTES:

1. 208/230 VOLT 60 Hz 1φ POWER SUPPLY. SEE DATA PLATE FOR AMPACITY & FUSE SIZE. OPTIONAL CKT BKR SHOWN.
2. FACTORY PROGRAMMED ECM MOTOR.
3. TRANSFORMER IS FACTORY WIRED FOR 230 VOLT OPERATION. FOR LOWER VOLTAGES, INTERCHANGE ORANGE AND RED LEADS. INSULATE UNUSED LEADS.
4. ALTERNATE DEVICE IS NOT ADJUSTABLE AND HAS ORANGE LEADS.
5. CRANKCASE HEATER MAY NOT BE REQUIRED ON ALL COMPRESSORS.
6. COMPRESSOR TIME DELAY AND FAN PURGE DELAY ARE LOCATED ON THE PCB (PRINTED CIRCUIT BOARD) AND ARE ADJUSTABLE.
7. THE (STATUS LED) WILL BLINK ONE TIME AFTER THE HPS (HIGH PRESSURE SWITCH) HAS OPENED TWICE AND THE UNIT WILL LOCKOUT. THE (STATUS LED) WILL BLINK TWICE AFTER THE LPS (LOW PRESSURE SWITCH) HAS OPENED TWICE AND THE UNIT WILL LOCKOUT.
8. THE LOCKOUT CIRCUIT CONTACTS ARE N.O. BETWEEN TERMINALS 5 AND 7 OF THE LOW VOLTAGE TERMINAL BOARD AND N.C. BETWEEN TERMINALS 7 AND 6 OF THE LOW VOLTAGE TERMINAL BOARD.

Figure 1b. Typical Electrical Schematic - (Economizer) Model EAA

Chapter 2 Electronic Control Board

2.1 Introduction



WARNING

Failure to observe the instructions contained in this document may result in personal injury and/or property damage and may void the warranty. Read this manual before installing, replacing or using this product.

Eubank's proprietary Printed Circuit Board (PCB) sets the standard for the industry in flexibility, reliability and performance. This UL certified component is engineered to optimize Heating, Cooling and Dehumidification operation while communicating valuable information to the end user. Special features include 2-Stage operation with varying speed control to optimize latent and sensible capacity, built in remote communication (Modbus) for monitoring and/or control, optimized head pressure control and configurable menu options for various operations and control. The Eubank PCB comes equipped with seven segment display to annunciate faults, which drastically reduces troubleshooting time and system downtime. Lockout contacts are also provided along with the alarms being transferred via Modbus.

This chapter provides the necessary information for installing and operating the Eubank PCB. The diagram below identifies the inputs, outputs and connections for the Eubank PCB. See I/O table.

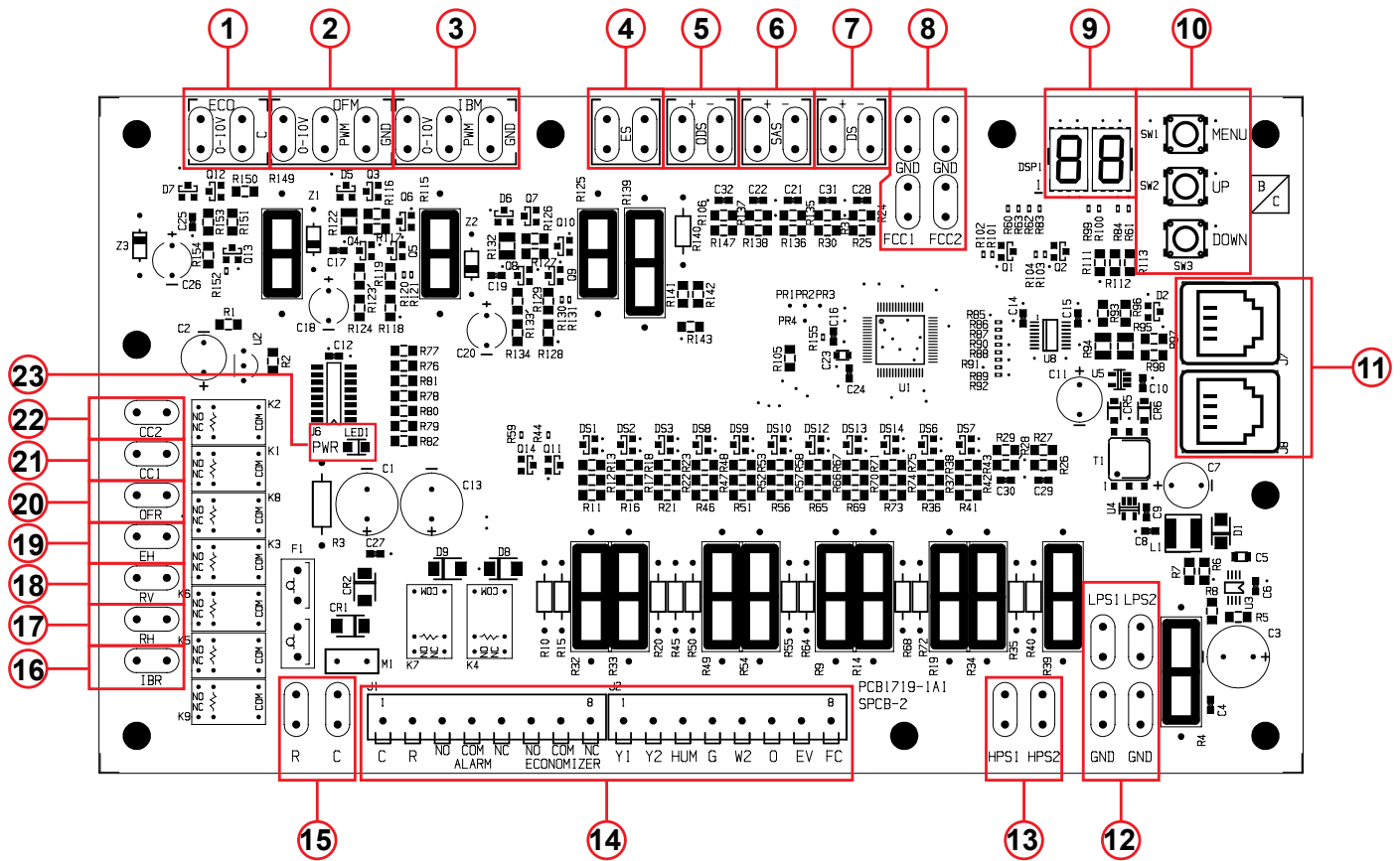

Item	Description
1	Economizer Actuator Output 2-10 VDC
2	Outdoor Motor Control Output 0-10 VDC or PWM
3	Indoor Motor Control Output 0-10 VDC or PWM
4	Enthalpy Sensor Signal Input 4-20mA
5	Outdoor Sensor Signal 10K NTC (Heat Pumps) / Dry Bulb Sensor Signal Input 10K NTC (Systems Equipped with Dry Bulb Economizer)
6	Supply Air Sensor Signal Input 10K NTC (Systems Equipped with Economizer)
7	Defrost Sensor Signal Input 10k NTC (Heat Pumps Only)
8	Head Pressure Control Sensor Signal 10k NTC (ECM Motors)
9	Control Board Menu/Fault Display
10	Menu/Up/Down Selection Buttons
11	Modbus RJ11 Communications Ports
12	Low Pressure / Freeze Sensor Signal Input 10k NTC
13	High Pressure Switch Input (Normally Closed)
14	Thermostat Inputs/Alarm And Status Terminals
15	24 VAC To Power Board (18 VAC To 30 VAC)
16	Indoor Blower Output 24 VAC (PSC Motors)
17	Reheat Output 24 VAC (Hot Gas Or Electric Reheat Dehumidification)
18	Reversing Valve Output 24 VAC (Heat Pumps Only)
19	Electric Heat Output 24 VAC
20	Outdoor Fan Output 24 VAC (PSC Motors)
21	Compressor 1/1st Stage Output 24 VAC (Single Stage Compressor)
22	Compressor 2/2nd Stage Output 24 VAC (Dual Compressor System 2nd Compressor) (Single Compressor 2nd Stage)
23	Control Board Power Indicator LED

2.2 Installation and Replacement

The PCB is factory installed. To install a replacement PCB, use the six mounting holes along with the appropriate screw size to firmly secure the board to the control box. After this is achieved, follow the wiring diagram and menu configuration for the respective system for appropriate operation. Ensure that the terminals used do not make any unwanted electrical connection (via strands etc.) with any other terminals. Please allow a 1” creepage distance between the board and all other adjacent electrical components.

2.3 PCB Details and Information

The PCB is equipped with an on board seven-segment display (Item #9) for configuring various settings and displaying faults. During normal operation the display remains off unless the configuration menu is accessed or a fault has occurred. Faults will be annunciated on the display as shown below:



Display	Displayed Faults
AS-F	Supply Air Sensor Fault (Sensor Disconnected Or Faulty) If Equipped
DB-F	Dry Bulb / Outdoor Sensor Fault (Sensor Disconnected Or Faulty) If Equipped
DS-F	Defrost Sensor Fault (Sensor Disconnected Or Faulty) Heat Pumps Only
ES-F	Enthalpy Sensor Fault (Sensor Disconnected Or Faulty) If Equipped
LP-1	Low Pressure Lockout Compressor Circuit 1
LP-2	Low Pressure Lockout Compressor Circuit 2
HP-1	High Pressure Lockout Compressor Circuit 1
HP-2	High Pressure Lockout Compressor Circuit 2
03	Low Voltage "Brownout" 16VAC or Less for 10 Minutes

2.3.1 – Programming Menu Configuration

1. To Enter Programming Mode:
 - Press and hold the *Menu* button for 5 seconds until **P-01** is displayed.
2. While in Programming Mode main menu:
 - Press the *Menu* button to enter the displayed parameter menu.
 - Press the Up/Down buttons to adjust the current parameter number.
 - The current parameter number will be displayed seven segments alternating showing "P-" and the number every 0.5s.
3. While in parameter menu:
 - The current parameter selection will be displayed seven segments.
 - Press the *Menu* button to save the current parameter selection return to the programming main menu.
 - Press the Up/Down buttons to adjust the current parameter selection.
4. To exit programming mode, press and hold the *Mode* and *Up* buttons while in the programming main menu.
 - Press and hold the *Menu* button for 5 seconds.
 - **Note:** The control will automatically exit the programming mode after 2 minutes with no activity.

Note: 100 will be displayed by alternating between "1" and "00" every 0.5s.

Configuration Menu				
Menu Setting	Name	Default	Selections	General Description
1	AC/HP Select	AC	AC, HP	HP = Heat Pump Unit, AC = AC Unit
2	IBM Select	P	P, dC	P = PWM, dC = 0-10V
3	FAN PURGE	90	N, 10-90	Indoor Blower off delay in seconds
4	IBM Y1 Set	80	40-100	"G" Fan only and "Y1" 1st Stage Cooling Indoor Blower Speed Setting
5	IBM Y2 Set	100	40-100	"Y2" 2nd Stage Cooling Indoor Blower Speed Setting
6	OFM Select	P	P, dC	P = PWM, dC = 0-10V
7	OFM Set	80	65-100	Outdoor Fan Motor Max Speed setting
8	Defrost Timer	30	30, 60, 90	Defrost cycle timer in minutes
9	EHDD select	Y	Y, n	CAN ONLY BE "Y" IF SCKT IS "N"
10	SCKT select	n	Y, n	SCKT= Y OVERRIDES EHDD
11	ODS set	50	0-70	Outdoor Sensor for HP or Econo. Dry Bulb Setpoint
12	ECONO select	n	Y, n	n = Disabled (No Econo.), Y = Enabled (W/Econo.)
13	Sensor Type	EN	EN or DB	Economizer sensor type selection EN= Enthalpy, DB = Dry Bulb
14	ECONO set	d	A-E	Selections A=73F, B=70F, C= 67F, D =63F E= 55F all @ 50%RH (Only available if EN sensor type is selected)
15	MIN POS	20	20-100	Sets the damper position for Minimum Open
16	W2 speed	100	70-100	Sets the Indoor Blower Speed for Electric Heat
17	Dehum speed	80	60-100	Sets the Indoor Blower Speed for Dehumidification
18	DS calibration	0	-18	Defrost Sensor Calibration
19	SAS calibration	0	-18	Supply Air Sensor Calibration
20	T'STAT Select	H	H, C	H = hardwired 24V Tstat, C = communicating Tstat
21	Modbus ID	1	36161	Sets the Modbus ID for the unit
22	Modbus BAUD rate	19	9.6, 19	Available Baud Rates 9.6 = 9600, 19 = 19200
23	Modbus timeout	25	21916	Communications Timeout in minutes
24	Test	n	Y, n	When set to "Y" all timers are reduced for testing
25	SW version number	N/A	N/A	Displays the current version software

Configuration Menu Details

- 1. AC/HP Select:** This setting allows the PCB to be configured for AC (air-conditioner) or HP (heat-pump). The system type is configured at the factory during production testing for the appropriate system type. The default system type is AC.
- 2. IBM Select:** This setting allows the IBM (Indoor Blower) control signal to be configured for PWM or 0-10vdc control. The default control output signal is PWM.
- 3. Fan Purge:** This setting allows the delay off time of the indoor blower once the call for the indoor blower has been removed. The selections are N (no delay) or 10-90 seconds. After the default time of 90 seconds the indoor blower will shut off. Selecting the N (no delay) will allow the Indoor blower to shut off immediately after any request has been removed.
- 4. IBM Y1 Set:** This is an independent setting for the speed at which the Indoor blower will operate upon a request for Y1 (1st stage cooling) via Digital Input or Modbus. The default setting for the IBM Y1 Set is 80% of maximum speed. The speed may be adjusted from 40-100% in 1% increments to meet desired airflow requirements. Note: Adjusting the speed too low will result in coil freezing.
- 5. IBM Y2 Set:** This is an independent setting for the speed at which the Indoor blower will operate upon a request for Y2 (2nd stage cooling) via Digital Input or Modbus. The default setting for the IBM Y1 Set is 100% of maximum speed. The speed may be adjusted from 40-100% in 1% increments to meet desired airflow requirements.
Note: Adjusting the speed too low will result in coil freezing, low-pressure or high-pressure lockout.
- 6. OFM Select:** This setting allows the IBM (Indoor Blower) control signal to be configured for PWM or 0-10vdc control. The default control output signal is PWM.
- 7. OFM Set:** This is an independent setting for the max speed at which the Outdoor fan will operate. The default setting for the OFM Set is 80% of maximum speed. The speed may be adjusted from 65-100% in 1% increments to meet desired airflow requirements.
Note: Adjusting the speed too low will result in coil freezing, low-pressure or high-pressure lockout.
- 8. Defrost Timer:** The defrost timer only applies to Heat-pump systems (when setting 1 is set to HP). This is the accumulation timer used to monitor for heat-pump defrost control. The selections for defrost timing is 30, 60 and 90 minutes. The defrost timer accumulates the compressor runtime in the heat-pump mode and monitors the defrost sensor for freezing conditions to initiate a defrost cycle at the selected defrost timing interval. The default defrost time is 30 minutes.
- 9. EHDD Set:** The Electric heat during defrost setting allows the electric heat to operate when a defrost cycle is being performed in heat-pump mode. The selections for the EHDD Set are Y (yes) or N (no). When set to N (no) the electric heat will not operate automatically during a defrost cycle in heat-pump mode. When the EHDD Set is set to Y (yes, Default) the electric heat will operate upon each defrost cycle in the heat-pump mode.
Note: EHDD and SCKT cannot both be set to the Y (yes) selection at the same time. SCKT takes priority over EHDD.
- 10. SCKT Set:** The SCKT setting is used to prevent simultaneous operation of the electric heat and compressor. The selections for the SCKT Set are Y (yes) or N (no). When set to N (no, Default) the electric heat will be allowed to operate with the compressor in heat-pump mode upon a call

for W2 (auxiliary / emergency heat). When the SCKT Set is set to Y (yes) the electric heat will not be allowed to operate with the compressor in the heat-pump mode. When set to Y (yes) and upon a request for W2 (auxiliary / emergency heat) the compressor will shut off and the electric heat will operate.

Note: SCKT and EHDD cannot both be set to the Y (yes) selection at the same time. SCKT takes priority over EHDD.

- 11. ODS Set:** The ODS Set is used to set the Outdoor Sensor temperature for Heat-pump systems. When the system type is configured for Heat-pump (when setting 1 is set to HP), the ODS Set allows the outdoor sensor to be used to govern when electric heat is allowed to operate. When the outdoor temperature is below the ODS setpoint, the electric heat will be allowed to operate. The adjustable range is 0F-70F in 1F increments with a default setpoint of 50F.
- 12. ECONO Select:** The ECONO Select is used to select whether the system has an economizer system installed or not. When set to the Y (yes) selection the system will include the economizer cooling algorithm within its sequence of operation and utilize the economizer package when conditions are favorable for economizer cooling. When set to the N (no) selection the system will only utilize the compressor for cooling operation. This setting is configured at the factory during production testing for the appropriate system type.

Note: When ECONO Set is set to Y (yes) the system must have an Enthalpy or Dry Bulb and Supply Air sensor connected and properly selected in setting 13 in order to operate in economizer cooling. The system will default to compressor cooling if any sensor becomes disconnected or faulty. Changing the ECONO Select to N (no) will disable economizer operation and the economizer function will be ignored.
- 13. Sensor Type:** This setting is used for selecting the type of economizer sensor used EN (Enthalpy) or DB (Dry Bulb). The appropriate sensor must be connected and selected for economizer operation. This setting is configured at the factory during production testing for the appropriate sensor type.
- 14. ECONO Set:** This setting is used to set the economizer setpoint at which the economizer is allowed to operate for cooling. When setting 13 is set for EN (Enthalpy), the selections are A=73F, B=70F, C=67F, D=63F and E=55F all at 50% relative humidity. The A–E selections will only be available when setting 13 is set to EN (Enthalpy). When setting 13 is set for DB (Dry Bulb), the selection is from 20F to 105F in 1F increments. The 20F-105F range will only be available when setting 13 is set to DB (Dry Bulb).
- 15. MIN POS:** The MIN POS setting is for setting the minimum position of the economizer or motorized damper. When set above 20 (2vdc) the damper will remain open to the selected position at all times, hence minimum position. The adjustable range is from 20 (2vdc) to 100 (10vdc) in 1vdc increments.
- 16. W2 Speed:** This is an independent setting for the speed at which the Indoor blower will operate upon a request for W2 (Electric heat) via Digital Input or Modbus. The default setting for the W2 speed is 100% of maximum speed. The speed may be adjusted from 70-100% in 1% increments to meet desired airflow requirements.

Note: Adjusting the speed too low will result in increased supply air temperatures in electric heat mode.
- 17. Dehum Speed:** This is an independent setting for the speed at which the Indoor blower will operate upon a request for HUM (Dehumidification) via Digital Input or Modbus. The default setting for

the Dehum speed is 80% of maximum speed. The speed may be adjusted from 60-100% in 1% increments to meet desired airflow requirements.

- 18. DS Calibration:** This setting is used to calibrate the defrost sensor from 0 to -18F.
- 19. SAS Calibration:** This setting is used to calibrate the supply air sensor from 0 to -18F.
- 20. T'STAT Select:** The thermostat type can be selected with this setting for an option of H= Hardwired 24vac Thermostat or C = Communicating Thermostat via Modbus. The default setting is H= Hardwired 24vac Thermostat.
- 21. Modbus ID:** This setting allows the Modbus ID to be entered for Modbus communications for the unit. The range for the Modbus ID is 1 – 36161 the default Modbus ID is 1.
- 22. Modbus Baud Rate:** This setting allows the Modbus Baud Rate to be entered for Modbus communications. The available Baud Rates are 9.6= 9600 and 19= 19200. The default Modbus Baud Rate is 19 = 19200.
- 23. Modbus Timeout:** This is the setting for the Modbus communications timeout in minutes. The range of communications timeout is from 25 minutes to 21916 minutes. The default communications timeout is 25 minutes.
- 24. Test:** The Test feature has two options Y= Yes or N= No. When this setting is set to Y=Yes, all circuit timers are reduced to expedite testing for various system operations. When set to N=No, all circuit timers are used in their default configuration and normal operation.
- 25. Software Version Number:** The software version of the 92589-control board will be displayed on the seven-segment display. This is for informational purposes only.

2.4 Operation

Power

The Eubank PCB requires 24 VAC to operate. When the board is sufficiently powered, the “PWR” status light on the PCB illuminates “Green.” When the power supply voltage is 16vac or less for 10 seconds the control board will de-energize all outputs. This is considered a voltage brownout (low voltage) condition and the display of the control board will show “03” as an indicator of brownout (low voltage). When the voltage rises back to 17 VAC, the control board will allow the system to operate.

Note: The nominal power supply for the control board is 24 VAC and this voltage should be confirmed during startup to assure normal operation.

Communication

The Eubank PCB comes equipped the Modbus communications standard. There are 2 adjacent RJ11 Modbus communication ports connected in parallel. That is, both ports transmit the same information. The board allows you to set the Baud Rate at 9600 bits per second or 19200 bits per second. The board also allows the Modbus ID to be selected in the configuration menu with the available range from 1 to 36161. The default Modbus ID is 1. *See section 2.1 for reference.*

2.5 Sequence of Operation

IMPORTANT

All equipment should go through the recommended commissioning/start up sequence to ensure safety and system reliability. This document is only valid if the system is used as intended.

This section defines the manner and method of control of the HVAC system. It will cover the following operations and protections.

1.0 Indoor Blower Operation

- 1.1 G - Indoor Blower Only
- 1.2 Y1 - Indoor Blower Operation
- 1.3 Y2 - Indoor Blower Operation
- 1.4 W2 – Indoor Blower Operation
- 1.5 HUM – Indoor Blower Operation

2.0 Cooling Operation AC / HP

- 2.1 Mechanical Cooling (AC systems)
 - 2.1.1 Partial Capacity
 - 2.1.2 Full Capacity
- 2.2 Mechanical Cooling (HP systems)
 - 2.2.1 Partial Capacity
 - 2.2.2 Full Capacity

3.0 Economizer Operation

- 3.1 Enthalpy Sensor and Operation
- 3.2 Dry Bulb Sensor and Operation
- 3.3 Supply Air Sensor
- 3.4 Minimum Position

4.0 Heating Operation AC / HP

- 4.1 Electric Heat (AC systems)
- 4.2 Heat Pump Heating Operation
- 4.3 Defrost Operation (Heat Pumps)
- 4.4 Electric Heat / Outdoor Sensor / SCKT / EHDD (Heat Pumps)

5.0 Dehumidification Operation AC / HP

- 5.1 Hot Gas Reheat
- 5.2 Electric Reheat

6.0 Refrigeration Protection

- 6.1 High Pressure lockout
- 6.2 Low Pressure Lockout / Freeze Protection
- 6.3 Anti Short Cycle

7.0 Additional Features

- 7.1 Modulating Head pressure Control (ECM Outdoor Motors)
- 7.2 Emergency Ventilation
- 7.3 Forced Cooling
- 7.4 Modbus Communications
- 7.5 Low Voltage (Brownout)

8.0 Smoke / Fire Shutdown

- 8.1 System Shutdown Contact Wiring

Note: Equipment, devices and necessary system components are specified in the respective section.

Note:

- 1. All inputs on the control board go through a 5 seconds Time-On Delay to prevent nuisance request. Compressor Outputs go through 5 seconds staggered Time On delay to prevent nuisance tripping of breaker due to the inrush associated with these large inductive loads.
- 2. Normal Operating Mode describes a mode in which there are no active faults which would interrupt the operation of the system.

1.0 Indoor Blower Operation

The speed at which the indoor blower will operate is based on the discrete operational inputs that have 24vac applied. These inputs are listed below.

- 1.1 G Input** – A request for Fan Only (independent G-signal via Digital input or Modbus), results in the indoor motor turning “ON” and operating at the “Y2” (BY DEFAULT) motor speed (Only Applicable for EC motors).
- 1.2 Y1 Input** – A request for Y1 (independent Y1-signal via Digital input or Modbus), results in the indoor motor turning “ON” and operating at the “Y1” motor speed (Only Applicable for EC motors).
- 1.3 Y2 Input** – A request for Y2 (independent Y2-signal via Digital input or Modbus), results in the indoor motor turning “ON” and operating at the “Y2” motor speed (Only Applicable for EC motors).
- 1.4 W2 Input** – A request for W2 (independent W2-signal via Digital input or Modbus), results in the indoor motor turning “ON” and operating at the “W2” motor speed (Only Applicable for EC motors).
- 1.5 HUM Input** – A request for HUM (independent HUM-signal via Digital input or Modbus), results in the indoor motor turning “ON” and operating at the “HUM” motor speed (Only Applicable for EC motors).

When there is a request for Indoor Fan (G-input High) along with a request for cooling, heating or dehumidification, the G-Input becomes lowest priority. This means that in any combination involving the G-input, the speed associated to Fan Only will never take precedence.

The priority list from Highest to Lowest goes as follows:

1. Y2 - Request
2. Y1 - Request
3. W2 - Request
4. HUM - Request
5. G - Request

Note: The priority list above also describes the operation that takes precedence in the event that there is a request for all operations or a combination of operations. The controller will NOT energize the compressor outputs and the heater output simultaneously if configured for AC. The controller WILL energize the compressor outputs and the heater output simultaneously if configured for HP.

The speed at which the Indoor Fan Operates during Stage 1 (Y1) and Stage 2 (Y2) Cooling Request can be set directly at the board using the configuration menu settings 4 and 5. All requests are interlocked with the Indoor Fan and will run the Fan at the respective speed associated with the operation. This means that a lone call for Stage 1 (Y1) Cooling will automatically run the Indoor Fan at Stage 1 (Y1) Cooling Speed even without a request for Indoor Fan. This holds true for all request.

2.0 Cooling Operation

AC Systems Request	Active Input	Active Output
Stage 1 Cooling (Fixed Compressor)	Y1	CC1 (Partial Capacity)
Stage 1 Cooling (2 Fixed Compressors)	Y1 or Y2	CC1 or CC2 Respectively (Partial Capacity)
Stage 1 Cooling (1 Staged Compressor)	Y1	CC1 (Partial Capacity)
Stage 2 Cooling (2 Fixed Compressors)	Y1 + Y2	CC1 + CC2 (Full Capacity)
Stage 2 Cooling (2 Staged Compressors)	Y1 + Y2	CC1 + CC2 (Full Capacity)

2.1 Mechanical Cooling (AC systems) – This section will describe the sequence of operation which takes place during Direct Expansion (DX) cooling from a control standpoint.

Note: The system type must be configured for “AC” operation in setting 1 of the configuration menu of the control board for proper AC system operation. This system type is selected at the factory and there’s no need to change this setting.

2.1.1 Y1 Cooling (Partial Capacity 1st Stage) – In normal operating mode, a request for “Stage1 Cooling” Y1-signal via Digital input or Modbus), energizes Compressor 1 Relay Output (CC1) on the PCB. The controller provides a continuous control signal associated to the Indoor Fan Motor, that is proportional to the “Y1” speed setting on the board or via Modbus. It also outputs a request dependent (based on FCC IN) control signal for the Outdoor Fan Motor (Only applicable to ECM motors). In Stage 1 Cooling operation, the compressor operates at partial capacity and the indoor fan remains on continuously but the outdoor fan modulates based on liquid line temperature. The Fan Cycle Control Sensor (Low Ambient Control Sensor) monitors the liquid line to maintain a 90F liquid line temperature. When the liquid line temperature is below 80F the outdoor fan will shut off. A liquid line temperature above 115F will force the outdoor fan to operate at the maximum speed set on the control board for setting 7 in the configuration menu. The outdoor fan will speed up and slow down between liquid line temperature of 80F and 115F. Systems with (PSC Outdoor Motors) utilizes a Fan Cycle Switch which closes at 400 PSIG to energize the OFR (outdoor fan relay) to start the outdoor fan which runs until the switch reopens (at 290 PSIG). These outputs function as described until the Cooling setpoint is satisfied. This is considered as ON/OFF fan cycle control and the PSC motor will not modulate.

Note: Single Stage compressors operate at full capacity upon a request for Y1.

2.1.2 Y1 and Y2 Cooling (Full Capacity 2nd Stage) – If the space temperature continues to increase pass the defined differential, Stage 2 Cooling (Y2-input) is energized. Under normal operation, this energizes the Compressor 2 Output (CC2). The Indoor Fan motor, will operate at “Y2” speed instead of “Y1” speed since Y2 has higher priority. These outputs remain energized until the cooling setpoint is satisfied. Once the setpoint is satisfied, the Compressor and the Outdoor fan outputs are de-energized. The Indoor motor continues to run based on the fan purge timer setpoint (default 90 seconds) selected in setting 3 of the configuration menu of the control board.

Note: 2 Stage compressors require a request for Y2 to operate at full capacity in Cooling operation. All Air-conditioners and Heat Pump systems with 2 stage compressors are allowed 2 stage cooling operation.

2.2 Mechanical Cooling (HP systems) – This section will describe the sequence of operation which takes place during Direct Expansion (DX) cooling from a control standpoint. The reversing valve (O Input) must be energized for Cooling operation on Heat Pump systems.

Note: The system type must be configured for “HP” operation in setting 1 of the configuration menu of the control board for proper HP system operation. This system type is selected at the factory and there’s no need to change this setting.

2.2.1 Y1+ O Cooling (Partial Capacity 1st Stage) – In normal operating mode, a request for “Stage1 Cooling” Y1 + O signal via Digital input or Modbus), energizes the Reversing Valve Output (RV) and Compressor 1 Relay Output (CC1) on the PCB. The controller provides a continuous control signal associated to the Indoor Fan Motor, that is proportional

to the “Y1” speed setting on the board or via Modbus. It also outputs a request dependent (based on FCC IN) control signal for the Outdoor Fan Motor (Only applicable to ECM motors). In Stage 1 Cooling operation, the compressor operates at partial capacity and the indoor fan remains on continuously but the outdoor fan modulates based on liquid line temperature. The Fan Cycle Control Sensor (Low Ambient Control Sensor) monitors the liquid line to maintain a 90F liquid line temperature. When the liquid line temperature is below 80F the outdoor fan will shut off. A liquid line temperature above 115F will force the outdoor fan to operate at the maximum speed set on the control board for setting 7 in the configuration menu. The outdoor fan will speed up and slow down between liquid line temperature of 80F and 115F. Systems with (PSC Outdoor Motors) utilizes a Fan Cycle Switch which closes at 400 PSIG to energize the OFR (outdoor fan relay) to start the outdoor fan which runs until the switch reopens (at 290 PSIG). These outputs function as described until the Cooling setpoint is satisfied. This is considered as ON/OFF fan cycle control and the PSC motor will not modulate.

Note: Single Stage compressors operate at full capacity upon a request for Y1.

2.2.2 Y1 + Y2 + O Cooling (Full Capacity 2nd Stage) – If the space temperature continues to increase pass the defined differential, Stage 2 Cooling (Y1+Y2+O input) is energized. Under normal operation, this energizes the Compressor 2 Output (CC2). The Indoor Fan motor, will operate at “Y2” speed instead of “Y1” speed since Y2 has higher priority. These outputs remain energized until the cooling setpoint is satisfied. Once the setpoint is satisfied, the Compressor and the Outdoor fan outputs are de-energized. The Indoor motor continues to run based on the fan purge timer setpoint (default 90 seconds) selected in setting 3 of the configuration menu of the control board.

Note: 2 Stage compressors require a request for Y2 to operate at full capacity in Cooling operation. All Air-conditioners and Heat Pump systems with 2 stage compressors are allowed 2 stage cooling operation.

Note: With staged compressors, a CC2 output without a CC1 output will neither result in partial capacity nor full capacity. Only CC1 output can achieve partial capacity. Both CC1 and CC2 outputs are required to achieve full capacity.

3.0 Economizer Operation (If Equipped)

Damper Actuator

The damper actuator is a 24V motor that modulates the position of the damper blade. It is capable of driving a full 90 degrees within 90 seconds. The assembly has a spring return to close the damper during power outage.

3.1 Enthalpy Sensor and Operation – The enthalpy sensor responds to the total heat content of the outdoor air to provide the changeover to outside air for free cooling. The control board must be configured for proper operation of the economizer by selecting Y= Yes in the configuration menu setting 12. The sensor type must be selected in setting 13 for EN=Enthalpy. The desired changeover setpoint must be selected in setting 14 (default D=63F@50% rh). Example of Enthalpy Sensor and Enthalpy curve is shown below.

Note: Selecting N=No in configuration setting 12 will disable economizer operation.



Sever hazard. The economizer contains moving parts capable of causing serious injury or death. Disconnect power before removing the covering panel.



Enthalpy Setpoint is Setting 14 in control board configuration menu.

Options

- A= 73°F
- B= 70°F
- C= 67°F
- D= 63°F
- E= 55°F

All settings are @ 50%Rh

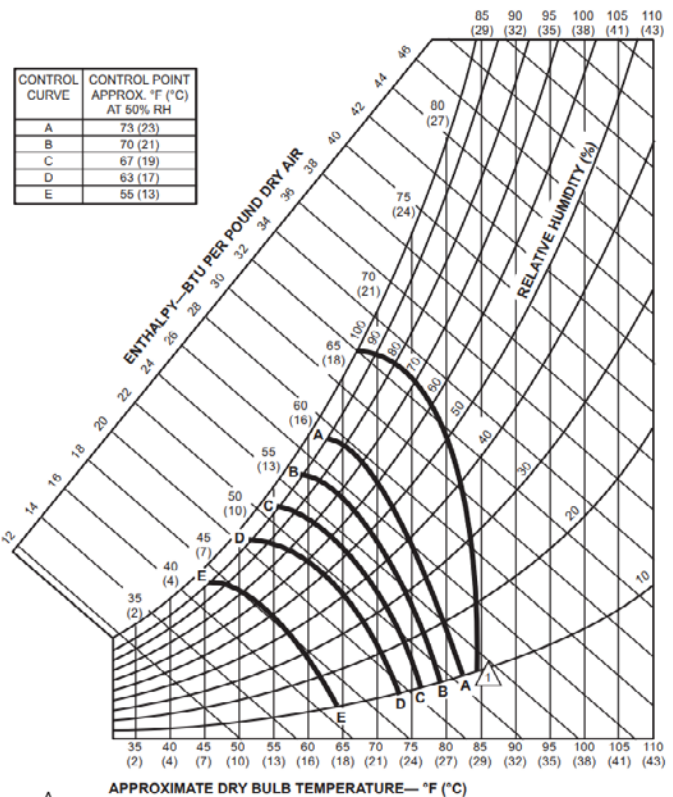

Figure 2. Enthalpy Sensor & Temperature Control Points

Enthalpy Operation

On a call for cooling from the wall-mounted thermostat, if outdoor conditions are suitable, the sensor will open the damper and admit outside air (i.e., economizer free cooling). If the outdoor ambient is too hot or humid (enthalpy sensor only), the sensor will place the actuator in the closed or minimum open position and activate mechanical cooling. The compressor is locked-out during the economizer cooling mode. The Supply Air sensor monitors the supply air of the system in economizer mode to modulate the economizer damper to maintain a 55F supply air temperature.

During the testing of the air conditioner at the factory, the control board has been configured for the sensor type used in the system. There should be no need to change the sensor configuration. If an enthalpy sensor is being used, setting 13 of the control board configuration menu will be set for EN= Enthalpy. A disconnected or faulty enthalpy sensor is annunciated on the control board display as “ES-F”. Economizer operation is only allowed in Cooling Mode.

Note: A call for Y2 or FC Inputs or a faulty or disconnected enthalpy sensor will override the economizer operation and force the compressor to operate.

3.2 Dry Bulb Sensor and Operation – The dry bulb sensor only responds to the dry bulb temperature of the outside air and ignores the humidity. The sensor is a 10K NTC sensor probe. The factory setting is 63°F. This setpoint can be adjusted in 1F increments from 20F to 105F in the control board configuration menu setting 14. Example of the dry bulb sensor is shown below.

Note: Selecting N=No in configuration setting 12 will disable economizer operation.



Figure 3. Dry Bulb Sensor

On a call for cooling from the wall-mounted thermostat, if outdoor conditions are suitable, the sensor will open the damper and admit outside air (i.e., economizer free cooling). If the outdoor ambient is too hot (dry bulb sensor only), the sensor will place the actuator in the closed or minimum open position and activate mechanical cooling. The compressor is locked-out during the economizer cooling mode. The Supply Air sensor monitors the supply air of the system in economizer mode to modulate the economizer damper to maintain a 55F supply air temperature.

During the testing of the air conditioner at the factory, the control board has been configured for the sensor type used in the system. There should be no need to change the sensor configuration. If a dry bulb sensor is being used, setting 13 of the control board configuration menu will be set for DB=Dry Bulb. A disconnected or faulty dry bulb sensor is annunciated on the control board display as “db-F”. Economizer operation is only allowed in Cooling Mode.

Note: A call for Y2 or FC Inputs or a faulty or disconnected dry bulb sensor will override the economizer operation and force the compressor to operate.

- 3.3 Supply Air Sensor** – The supply air sensor is a 10K NTC sensor probe mounted on a bracket in the supply air opening of the system. The probe senses the air temperature entering the structure, and provides a signal to the economizer controller for modulating the position of the damper. The default supply air temperature is 55F in economizer cooling and is not adjustable. A disconnected or faulty supply air sensor is annunciated on the control board display as “AS-F”.

Note: A faulty or disconnected supply air sensor will override the economizer operation and force the compressor to operate.

- 3.4 Minimum Position** – The minimum position controls the amount of outside air introduced in the building when not in economizer operation or to meet a minimum outside air requirement to keep the damper open. This feature is only applicable to systems with economizer or ventilation damper options. The minimum position can be adjusted in the control board configuration menu with setting 15. The setpoint adjustments are from 20 (2vdc) to 100 (10vdc) in 1vdc increments. This is an independent adjustment and can be set to drive the ventilation damper open to any position from closed to fully opened. A selection of 20 (2vdc) is the same as being set to OFF or fully closed.

4.0 Heating Operation

- 4.1 Electric Heat (AC Systems with Electric Heat)** – When there is a request for “Electric Heat” (W2-signal via Digital input or Modbus), the system will run the Indoor Motor for 10 seconds prior to energizing the Heater Output. The Indoor Motor will operate at the “W2” speed setting on the board or via Modbus. Once the Heater output is energized, the Heater comes on at full capacity (no staging). The Heater will remain on until the Heating setpoint is satisfied and the request is dropped. Once the heating setpoint is satisfied, the Indoor motor continues to run based

on the fan purge timer setpoint (default 90 seconds) selected in setting 3 of the configuration menu of the control board.

Note: A request for Cooling and Heating at the same time is not allowed and control board will not allow the electric heat to operate.

- 4.2 Heat Pump Heating Operation** – This section will describe the sequence of operation which takes place during Direct Expansion (DX) heating from a control standpoint. The reversing valve (O Input) must NOT be energized for Heating operation on Heat Pump systems.

Note: The system type must be configured for “HP” operation in setting 1 of the configuration menu of the control board for proper HP system operation. This system type is selected at the factory and there’s no need to change this setting.

In normal operating mode, a request for “Heat Pump Heating” Y1 signal via Digital input or Modbus), energizes the Compressor 1 and 2 Relay Output (CC1+CC2) on the PCB. The controller provides a continuous control signal associated to the Indoor Fan Motor, that is proportional to the “Y2” speed setting on the board or via Modbus. The system is defaulted to operate at Full capacity in heat pump heating mode. It also outputs a request for the Outdoor Fan to operate at the max speed. In heat pump Heating operation, the compressor operates at Full capacity and the indoor and outdoor fans remain on continuously. The outdoor fan does not modulate in heat pump heat mode.

- 4.3 Defrost Operation (Heat Pump Systems Only)** – The board has an integral accumulation run timer that runs on every request for heat pump heating. The system has a Defrost Sensor (DS) that monitors the outdoor coil circuit for freezing conditions. If the defrost sensor registers a temperature of 32°F while in the heat pump heating mode, it will initiate a defrost cycle based on the time selected in the control board configuration menu setting 8. The defrost time intervals selections are 30, 60 and 90 minutes and the factory default setting is 30 minutes. If the defrost sensor is still calling for defrost at the end of this delay, it will de-energize the outdoor fan, energize the reversing valve through the RV terminal, and keep the compressor energized. The defrost cycle will terminate on time or temperature. It will have a maximum defrost run time of 10 minutes, however, if the defrost sensor registers a temperature of 70°F or higher before the 10-minute maximum run time, the defrost cycle will terminate. If the defrost cycle has not completed (DS sensor above 70F) due the heating call being satisfied, the defrost cycle will continue upon the next call for heat pump heating to complete the defrost cycle. If freezing conditions are not present at the end of the defrost interval timer, the system will not perform a defrost cycle.

Note: If the DS sensor is disconnected or faulty, the compressor will not operate in heat pump heating mode and the control board display will annunciate the fault as “DS-F”.

Note: If “Yes” has been selected for Electric Heat During Defrost (EHDD) and “No” selected for the SCKT, the electric heat (EH) output will be energized during a defrost cycle to supply heat while the coil defrosts. *If the ODS is used, the electric heat will operate only if the outdoor temperature is below the ODS setpoint.*

- 4.4 Electric Heat / Outdoor Sensor / SCKT / EHDD (Heat Pumps) – Electric Heat (HP systems with electric heat)**– When there is a request for “Electric Heat” (W2-signal via Digital input or Modbus), the system will run the Indoor Motor for 10 seconds prior to energizing the Heater Output. The Indoor Motor will operate at the “W2” speed setting on the board or via Modbus. Once the Heater output is energized, the Heater comes on at full capacity (no staging). The Heater will remain on until the Heating setpoint is satisfied and the request is dropped. Once

the heating setpoint is satisfied, the Indoor motor continues to run based on the fan purge timer setpoint (default 90 seconds) selected in setting 3 of the configuration menu of the control board.

When the system is operating in Heat Pump mode the electric heat is considered as supplemental heat and will only be allowed under certain conditions due to additional features that may be used. These features include the Outdoor Sensor and SCKT (safety circuit). See ODS and SCKT for more details.

ODS - Outdoor Sensor (Heat-Pumps Only)

The outdoor sensor only responds to the temperature of the outside air. The sensor is a 10K NTC sensor probe. The factory setting is 50°F. This setpoint can be adjusted in 1F increments from 0F to 70F in the control board configuration menu setting 11.

If the optional Outdoor Sensor is used (Heat-pump systems only). The electric heat will not operate upon a request for “W2” unless the outdoor temperature is below the setpoint for the ODS setpoint. If the sensor is not connected or faulty the electric heat will be allowed to operate anytime a request for W2 is present.

Note: A request for Cooling and Electric Heat at the same time is not allowed and the control board will not allow the electric heat to operate.

SCKT – Safety Circuit (Heat-Pumps Only)

The SCKT is a selectable menu option in the control board configuration menu setting 10. The options for this feature are Y=Yes or N=No. When set to Y=Yes, control board will prevent the compressor and electric heat from operating simultaneously. In this case the compressor will shut off upon a request for “W2” (Electric Heat). The compressor will remain off as long as the request for W2 is active. Once the request for W2 satisfies the compressor will be allowed to operate. The default setting for SCKT is N=No, the electric heat and compressor will be allowed simultaneous operation in the heat pump heating mode.

Note: If the ODS is used the electric heat will not operate unless the outdoor temperature is below the ODS setpoint.

EHDD – Electric Heat During Defrost (Heat-Pumps Only)

The EHDD is a selectable menu option in the control board configuration menu setting 9. The options for this feature are Y=Yes or N=No. When set to Y=Yes, control board will force the electric heat to operate during a defrost cycle unless SCKT is set to Y=Yes or the outdoor temperature is not below ODS (if equipped) setpoint. The default setting for EHDD is Y=Yes.

Note: SCKT takes priority over ODS and EHDD.

5.0 Dehumidification Operation AC / HP

5.1 Hot Gas Reheat (if equipped) – When there is a request for “Dehumidification” (HUM-signal via Digital input or Modbus), this will result in the control board energizing the Indoor Fan (IBR), Compressor 1 (CC1), Compressor 2 (CC2), Reversing Valve (RV) “heat pumps only” and the Reheat (RH) relay outputs on the board. This forces the system to operate in the full capacity cooling mode while energizing the reheat solenoid valve to allow hot gas to be introduced into the supply air stream of the system for dehumidification operation. The indoor fan motor will operate at the “Dehum” speed setting on the board or via Modbus. The indoor fan remains on continuously but the outdoor fan modulates based on liquid line temperature. The Fan Cycle Control Sensor (Low Ambient Control Sensor) monitors the liquid line to maintain a 90F liquid line temperature. When the liquid line temperature is below 80F the outdoor fan will shut off. A liquid line temperature above 115F will force the outdoor fan to operate at the maximum speed

set on the control board for setting 7 in the configuration menu. The outdoor fan will speed up and slow down between liquid line temperature of 80F and 115F. Systems with (PSC Outdoor Motors) utilizes a Fan Cycle Switch which closes at 400 PSIG to energize the OFR (outdoor fan relay) to start the outdoor fan which runs until the switch reopens (at 290 PSIG). These outputs function as described until the Dehumidification setpoint is satisfied. This is considered as ON/OFF fan cycle control and the PSC motor will not modulate.

Note: A request for Y1 or Y2 via digital input or Modbus takes priority over dehumidification operation and the hot gas reheat valve will de-energize.

5.2 Electric Reheat (if equipped) – When there is a request for “Dehumidification” (HUM-signal via Digital input or Modbus), this will result in the control board energizing the Indoor Fan (IBR), Compressor 1 (CC1), Compressor 2 (CC2), Reversing Valve (RV) “heat pumps only” and the Reheat (RH) relay outputs on the board. This forces the system to operate in the full capacity cooling mode while energizing the electric heat to allow heat to be introduced into the supply air stream of the system for dehumidification operation. The indoor fan motor will operate at the “Dehum” speed setting on the board or via Modbus. The indoor fan remains on continuously but the outdoor fan modulates based on liquid line temperature. The Fan Cycle Control Sensor (Low Ambient Control Sensor) monitors the liquid line to maintain a 90F liquid line temperature. When the liquid line temperature is below 80F the outdoor fan will shut off. A liquid line temperature above 115F will force the outdoor fan to operate at the maximum speed set on the control board for setting 7 in the configuration menu. The outdoor fan will speed up and slow down between liquid line temperature of 80F and 115F. Systems with (PSC Outdoor Motors) utilizes a Fan Cycle Switch which closes at 400 PSIG to energize the OFR (outdoor fan relay) to start the outdoor fan which runs until the switch reopens (at 290 PSIG). These outputs function as described until the Dehumidification setpoint is satisfied. This is considered as ON/OFF fan cycle control and the PSC motor will not modulate.

Note: A request for Y1 or Y2 via digital input or Modbus takes priority over dehumidification operation and the electric heat will de-energize.

6.0 Refrigeration Protection

6.1 High Pressure Lockout – This condition describes the abnormal rise in Head Pressure within system with an acceptable limit of 660 PSI (+/-20PSI). The fault will only be active when the High-Pressure Switch (Normally Closed) opens during a request for Cooling or Heat Pump Heating. The first time this fault condition occurs, the system cuts the compressor off WITHOUT locking out. Once the pressure normalizes (drops below 450 PSI), the system will resume operation if the cooling or heat pump heating call still exist. If this fault occurs a second time on the same Cooling or Heat pump heating request, the system locks out. Lockouts can be monitored using the control board display for the current fault. The fault for a high-pressure lockout will displayed as “HP-1” or “HP-2” followed by “F”. The faults can also be monitored via Modbus by reading the respective value based on the Modbus map that is provided. After this lockout condition is reached, the cooling/heat pump heating call must be cycled (on/off of respective request) or the system must be power cycled to clear the fault. For a 2-compressor system, each lockout is isolated to the respective circuit and will not interfere with the operation of the other circuit providing that the circuits operate independently. The system will continue to lockout until the problem is rectified.

6.2 Low Pressure Lockout / Freeze Protection – A10K Nominal NTC Thermistor is connected to the “LPS 1” and “LPS2” inputs of the control board for circuit 1 and circuit 2 respectively.

The sensor is secured to the common suction line of the system to monitor the suction line temperature.

This condition describes the abnormal fall in Suction Line Temperature below 9°F. This fault will only be active when the Low-Pressure Sensor detects suction line temperatures below 9°F during a request for Cooling / Heat pump heating. The Low-Pressure Sensor is bypassed on the initial call for cooling for 3 minutes to allow low ambient start-up of the system. Once these 3 minutes have elapsed plus a 2-minute validation timer (5 minutes total), if the sensor remains below 9°F, the system cuts the compressor off. The system will remain off for the defaulted 3-minute anti-short cycle time and then the system will restart the cooling / heat pump heating operation and the 3-minute bypass timer begins. Once these 3 minutes have elapsed plus a 2-minute validation timer (5 minutes total), if the sensor remains below 9°F the system locks out. Lockouts can be monitored using the control board display for the current fault. The fault for a low-pressure lockout will be displayed as “LP-1” or “LP-2” followed by “F”. The faults can also be monitored via Modbus by reading the respective value based on the Modbus map that is provided. After this lockout condition is reached, the cooling/heat pump heating call must be cycled (on/off of respective request) or the system must be power cycled to clear the fault. For a 2-compressor system, each lockout is isolated to the respective circuit and will not interfere with the operation of the other circuit providing that the circuits operate independently. The system will continue to lockout until the problem is rectified.

- 6.3 Anti-Short Cycle** – This is a built-in protection mechanism that increases the reliability of the compressor by protecting it from excessive short cycling. When the compressor goes off, due to any fault, emergency or if the cooling / heat pump heating setpoint is satisfied, a built-in 3-minute timer locks the compressor for that respective circuit out. This can be monitored and adjusted via Modbus by referencing the appropriate register. However, it can only be monitored at the board level by waiting for the 3 minutes to elapse.

7.0 Additional Features

- 7.1 Modulating Head Pressure Control (ECM Outdoor Motors)**– A 10K Nominal NTC Thermistor is connected to the “FCC1” and “FCC2” inputs for circuit 1 and circuit 2 respectively. The sensor is secured to the liquid line of the system to monitor the liquid line temperature. When this sensor is connected, the thermistor value is used as the process variable when controlling the head pressure. The controller modulates the Outdoor Fan Motor to maintain a 90°F temperature setpoint. The controller will always use the greater value of FCC1 and FCC2 input as the reference point. In the event that the Thermistor is disconnected, the controller reverts to the outdoor fan operating at the max speed setting selected on the control board configuration menu setting 7.

Note: Systems with PSC outdoor motors utilize a fan cycle switch in the refrigeration circuit for on/off fan cycle head pressure control.

PSC Motor Head Pressure Control

The onboard outdoor fan relay (OFR) is used to control the Fan Cycle Switch based on CC output to the Compressor. Once the compressor out (CC1) is energized the OFR output will also be energized and the fan cycle switch will cycle on and off at 290psi and 400psi. This will turn the Outdoor Fan Motor on and off to maintain the head-pressure of the system, the OFR output is only used on systems with PSC outdoor motor and Fan Cycle Switch (FCC) only.

- 7.2 Emergency Ventilation (Motorized Damper or Economizer Equipped Systems)**– When there is a request for “Emergency Ventilation” (EV-signal via Digital input or Modbus), the system will run the Indoor Motor at the “Y2” speed setting on the board or via Modbus and provide a

10vdc signal from the ECO output of the control board to drive the motorized damper fully open.

Note: The compressor and electric heat WILL NOT operate while in the emergency ventilation mode.

7.3 Forced Cooling (economizer equipped systems) – During economizer cooling, if a request for “Forced Cooling” (FC-signal via Digital input or Modbus) is present. The control board will force the economizer to close and start the compressor to operate at full capacity cooling. This is considered an override of the economizer in the event economizer cooling can’t keep up with the cooling demand in economizer mode. The Indoor Motor at the “Y2” speed setting on the board or via Modbus and the system will operate in normal cooling mode until the request for FC is satisfied. Once satisfied the system will be allowed to return to economizer operation if conditions are favorable.

7.4 Low Voltage (Brownout) – The control board monitors the 24 VAC power supply for low voltage protection. When the power supply voltage is 16 VAC or less for 10 seconds the control board will de-energize all outputs. This is considered a voltage brownout (low voltage) condition and the display of the control board will show “03” as an indicator of brownout (low voltage). When the voltage rises back to 17 VAC, the control board will allow the system to operate.

Note: The nominal power supply for the control board is 24VAC and this voltage should be confirmed during startup to assure normal operation.

8.0 Smoke / Fire Shutdown

8.1 System Shutdown Contact Wiring – Add Normally Closed Dry contacts as shown for immediate shutdown of HVAC upon contacts opening.

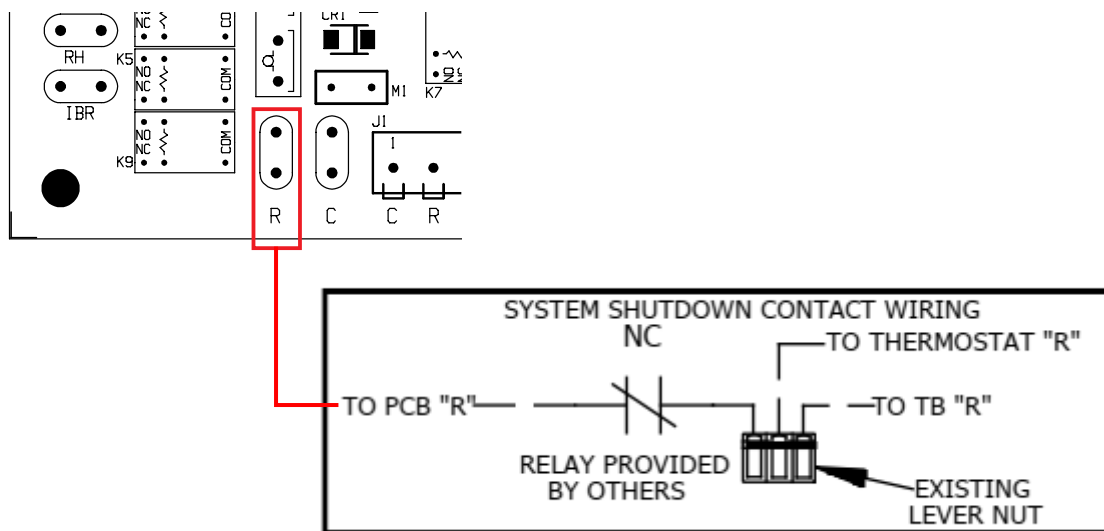

Chapter 3 Installation



WARNING

Failure to observe and follow Warnings and Cautions and these Instructions could result in death, bodily injury or property damage. Read this manual and follow its instructions and adhere to all Cautions and Warnings in the manual and on the A/C unit.

3.1 Equipment Inspection

Concealed Damage

Inspect all cartons and packages upon receipt for damage in transit. Remove cartons and check for concealed damage. **Important: keep the unit upright at all times.** Remove access panels and examine component parts. (Note: the "L"-shaped bottom bracket is screwed to the shipping pallet, against the air conditioner. Remove it before replacing the side screen). Inspect refrigerant circuit for fractures or breaks. The presence of refrigerant oil usually indicates a rupture. If damage is apparent, immediately file a claim with the freight carrier.

Units that have been turned on their sides or tops may have concealed damage to compressor motor mounts or to the oil system. If the unit is not upright, immediately file a claim for concealed damages and follow these steps:

1. Set unit upright and allow to stand for 24 hours with primary power turned on.
2. Attempt to start the compressor after 24 hours.
3. If the compressor will not start, makes excessive noise, or will not pump, return the unit to the freight carrier.

3.2 Installation Requirements

General

1. Inspect unit for completeness. Check for missing parts (e.g. hardware). Refer to the installation kit information in section 2.3.
2. Remove access panels and check for loose wires. Tighten screw connections.
3. Complete and mail the warranty registration card.

You must consider all of the following when choosing the installation site:

1. **Noise.** Install the unit so that the least amount of noise will be transmitted to inhabited spaces.
2. **Condensate Drainage.** Condensate produced during operation must be discharged to a suitable drain.
3. **Placement.**
 - A) Place the unit in a shaded area, if possible.
 - B) Install it above ground for protection against flooding.
 - C) The unit exhausts air. Be sure that the airflow is not impeded by shrubbery or other obstructions.
 - D) When installing multiple units, please note the recommended clearances noted in Table 4.
4. **Airflow Requirements:**

Note the maximum static pressure (Table 6). Keep duct lengths as short as possible. Do not obstruct airflow through the unit.

Duct work should be designed and installed in accordance with *all* applicable safety codes and standards. Eubank® strongly recommends referring to the current edition of the National Fire Protection Association Standards 90A and 90B *before* designing and installing duct work. The duct system must be engineered to insure sufficient air flow through the unit to prevent over-heating of

the heater element. This includes proper supply duct sizing, sufficient quantity of supply registers, and adequate return and filter areas. Duct work must be of correct material and must be properly insulated. Duct work must be constructed of galvanized steel with a minimum thickness of .019 inches. Duct work must be firmly attached, secured, and sealed to prevent air leakage. See section 2.4 for additional duct work requirements.

5. **Clearances:**

Note the minimum clearances required for proper operation and service.

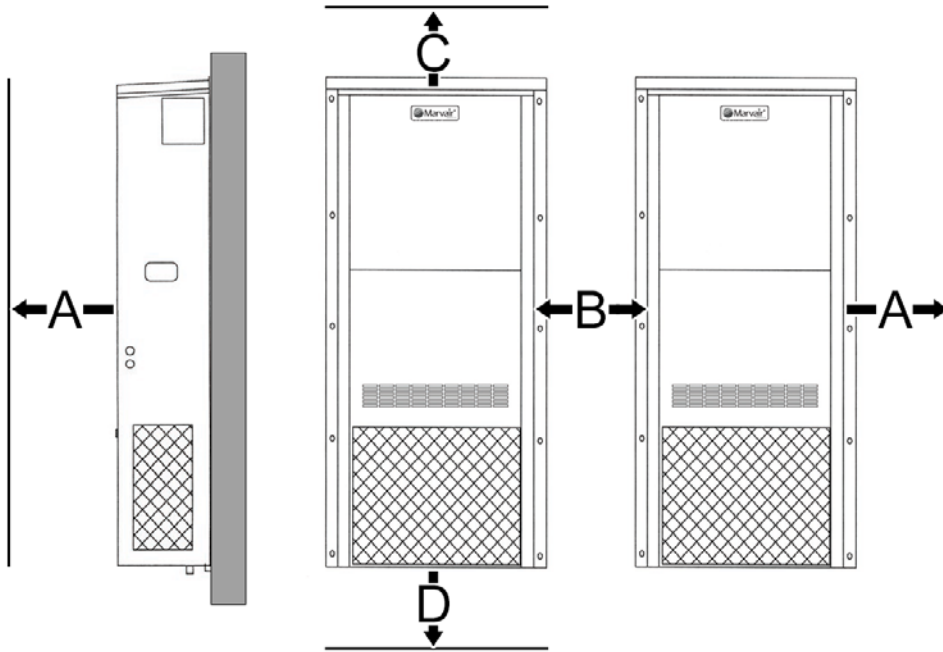

MODEL	MIN. CLEARANCE AROUND SIDES (SINGLE UNIT)	MIN. CLEARANCE BETWEEN UNITS (TWO UNITS)	MIN. SPACE ABOVE UNIT	MIN. SPACE BELOW UNIT
	A	B	C	D
1024	30 inches (76 cm)	18 inches (46 cm)	24 inches (61 cm)	6 inches (15 cm)
1030/1036	30 inches (76 cm)	18 inches (46 cm)	24 inches (61 cm)	6 inches (15 cm)
1042/1048/1060	30 inches (76 cm)	30 inches (76 cm)	24 inches (61 cm)	6 inches (15 cm)
1072	30 inches (76 cm)	30 inches (76 cm)	12 inches (31 cm)	6 inches (15 cm)

Table 6. Minimum Clearances

6. **Codes:**

Make sure your installation conforms to all applicable electrical, plumbing, building, and municipal codes. Some codes may limit installation to single story structures.

7. **Electrical Supply:**

The power supply must have the appropriate voltage, phase, and ampacity for the model selected. Voltage must be maintained above minimum specified values listed below. Refer to the data sticker on the unit for ampacity requirements.

Electrical Rating Designations*	A	C	D	Z
Nominal Voltage	208/230	208/230	460	575
Phase	1	3	3	3
Minimum Voltage	197	197	414	518
Maximum Voltage	253	253	506	632

* Letters refer to model number code designations. Refer to page 5.

Table 7. Voltage Limitations

3.3 Installation Materials

Installation Kits

Eubank air conditioners are shipped with one 12 Ga. "L" shaped bottom bracket. If you have not yet unpacked the unit, follow the instructions in section 2.1. All units have built-in full length mounting flanges. Therefore, use of mounting brackets is not required.

Kit Components:

1. One 12 Ga. "L"-shaped bottom bracket.

Accessories:

The package may include other factory-supplied items (optional) as follows on the next page:

Controllers/Thermostats

CommStat Touch HVAC Controller, Solid State Lead/Lag Controller P/N K/10439

CommStat 4 HVAC Controller, Solid State Lead/Lag Controller P/N S/07846

CommStat 3 HVAC Controller, Solid State Lead/Lag Controller P/N S/04581

Digital thermostat. 1 stage heat, 1 stage cool. 7 day programmable. Fan switch:

Auto & On. Auto-change over. Keypad lockout. Non-volatile program memory. P/N 50123

Digital thermostat. 2 stage heat, 2 stage cool. 7 day programmable. Fan switch:

Auto & On. Auto-change over. Status LED's. Backlit display.

Programmable fan. Non-volatile program memory. P/N 50107

Grilles/Wall Sleeves

Supply Grilles

EAA1020/1024 - 28" x 8" P/N 80675
(711 mm x 203 mm)

EAA1030/1036/1042/1048/1060/EGA1072..... P/N 80676
30" x 10" (762 mm x 254 mm)

EAA1060 Reverse Flow P/N 93197
30" x 16" (762 mm x 406 mm)

Return Grilles

EAA1020/1024 P/N 80678
28" x 14" (711 mm x 356 mm)

EAA1030/1036/1042/1048/1060/EGA1072..... P/N 80679
30" x 16" (762 mm x 406 mm)

EAA1060 Reverse Flow P/N 93198
30" x 10" (762 mm x 254 mm)

Return Filter Grilles

Used when filter must be changed from the interior. Not recommended for economizer equipped air conditioners.

Note: Filter used in Return Filter Grille is 1" (25 mm) thick.

EAA1020/1024 P/N 80672
28" x 14" (711 mm x 356 mm)

EAA1030/1036/1042/1048/1060/EGA1072..... P/N 80673
30" x 16" (762 mm x 406 mm)

Additional Items Needed:

Additional hardware and miscellaneous supplies (not furnished by Eubank®) are needed for installation. For example, the list below contains approximate quantities of items typically needed for mounting a unit on a wood frame wall structure. Concrete or fiberglass structures have different requirements.

- (10) **3/8" carriage head mounting bolts** for unit mounting flanges. The length needed is typically the wall thickness plus one inch.
- (20) **3/8" washers**
- (10) **3/8" hex nuts**
- (6) **3/8" x 2-1/2" lag screws** for bottom bracket
 - **Silicone Sealer** to seal around cracks and openings
 - **Minimum 5 conductor low voltage multicolored wire cable** (i.e. thermostat wire)
 - **Appropriate electrical supplies** such as **conduit, electrical boxes, fittings, wire connectors,** etc.
 - **High voltage wire**, sized to handle the MCA (minimum circuit ampacity) listed on the data plate.
 - **Over-Current Protection Device** sized in accordance with the MFS (maximum fuse size) listed on the unit data plate.

WARNING - FIRE HAZARD

Improper adjustment, alteration, service, maintenance or installation could cause serious injury, death and/or property damage.

Installation or repairs made by unqualified persons could result in hazards to you and others. Installation MUST conform with local codes or, in the absence of local codes, with codes of all governmental authorities have jurisdiction.

The information contained in this manual is intended for use by a qualified service agency that is experienced in such work, is familiar with all precautions and safety procedures required in such work, and is equipped with the proper tools and test instruments.

3.4 Porting and Duct Work

General Information

Note: The following instructions are for general guidance only. Due to the wide variety of installation possibilities, specific instructions will not be given. When in doubt, follow standard and accepted installation practices, or contact Technical Support for additional assistance.

Wall Openings (All EAA and EGA air conditioners)

Measure the dimensions of the supply and return ports on the unit.

Cut the openings in the exterior wall for the supply and return. **IMPORTANT: All units with electric heat must have 1" (25.4mm) clearance on all four sides of the supply outlet duct flange on the unit. The 1" (25.4mm) clearance must extend on all sides of the supply duct for the first 3 feet (1 meter) from the unit.**

IMPORTANT: Eubank® requires a minimum of 1" (25.4mm) from the surface of any supply ducts to combustible material for the first 3 feet (1 meter) of the duct.

For all air conditioners with electric heat, the wall sleeve **MUST** have 1" (25.4 mm) clearance around all four sides of the opening. Attach the perimeter flange of the wall sleeve to the framed opening with appropriately sized screws. Since electric heat can be added after the unit has been installed, Eubank recommends that all installations have the 1" (25.4 mm) clearance around the wall sleeve.

When installing the wall sleeve, the supply opening must be on top. The supply opening is smaller than the return air opening.

Ducting

Extensions should be cut flush with the inside wall for applications without duct work.

Applications using duct work should be designed and installed in accordance with *all* applicable safety codes and standards. Eubank® strongly recommends referring to the current edition of the National Fire Protection Association Standards 90A and 90B *before* designing and installing duct work. The duct system must be engineered to insure sufficient air flow through the unit to prevent over-heating of the heater element. This includes proper supply duct sizing, sufficient quantity of supply registers, adequate return and filter area. Ductwork must be of correct material and must be properly insulated. Duct work must be constructed of galvanized steel with a minimum thickness of .019 inches for the first 3 feet (1 meter). Ductwork must be firmly attached, secured and sealed to prevent air leakage. Do not use duct liner on inside of supply duct within 4 feet (122cm) of the unit.

Galvanized metal duct extensions should be used to simplify connections to duct work and grilles. Use fabric boots to prevent the transmission of vibration through the duct system. The fabric must be U.L. rated to a minimum of 197°F (92°C).

Minimum Airflow Requirements

The duct system must be engineered to assure sufficient air flow through the unit even under adverse conditions such as dirty filters, etc. Use **Table 6** below and **Table 1, CFM at External Static Pressure (Wet Coil)** in section 1.4.

BASIC MODEL	MAXIMUM STATIC
EAA1020/1024	.50
EAA1030/1036/1042	.50
EAA1048/1060	.50
EGA1072	.50

**Table 8. Maximum Static Pressure
(For units with 2" Pleated Filters)**

3.5 Fresh Air Hood (non-economizer air conditioners only)

The fresh air hood is located on the inside, behind the slots on the bottom front panel. To access the hood, remove the screws that hold the front panel. The air flow can be adjusted from no (0%) fresh air to approximately 15% of rated air flow of fresh air, in 5% increments. The hood is shipped from the factory in the closed position (no fresh air). To provide fresh air, remove the two screws on either side of the hood and reposition as desired.

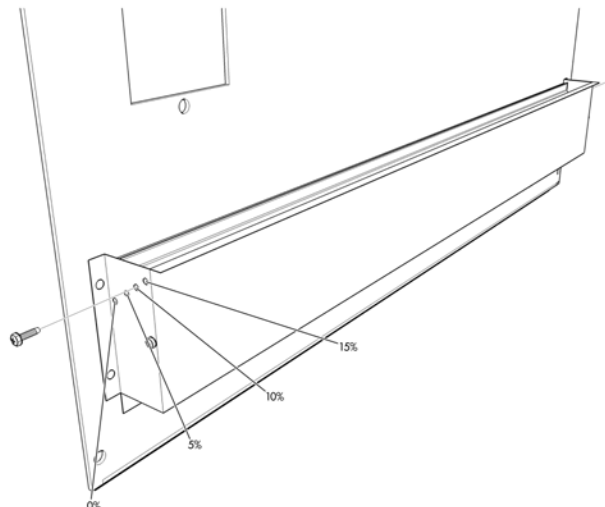

Figure 4. Fresh Air Hood Damper, Models 1024-1072

3.6 Bracket Installation

1. All models have built-in mounting flanges.
2. Apply a bead of silicone sealer on the wall side of the bottom support brackets on the unit. Circle the mounting holes with the silicone bead.
3. Refer to Figure 4. Attach the bottom support bracket to the wall using appropriate 3/8" diameter hardware.

For example, on wooden structures, use 3/8" x 2-1/2" all-thread lag screws. The screws must penetrate the center of the wall stud. Drill a pilot hole in the stud to prevent it from splitting.

3.7 Mounting The Unit

1. For wiring into the back of unit, locate the lower of the two knockouts on the wall side of the unit. Drill a one inch hole in the shelter wall to match this opening. Allow sufficient clearance to run 3/4" conduit through the hole and to the unit.
2. Using an appropriate and safe lifting device, set the unit on the bottom support bracket mounted on the wall. You must stabilize the unit on the bracket with the lifting device or by some other means - the bracket alone is not sufficient.
3. Make sure that the duct flanges are properly aligned with the wall opening. Adjust as necessary.
4. Note the holes in each side flange. Using the holes for guides, drill holes through the wall with a 3/8" drill bit. Insert the 3/8" x 5" bolts through the flanges. Install nuts and washers on the inside of the shelter. Tighten the bolts to secure the unit.
5. Apply a bead of silicone where the mounting flange contacts the unit and the shelter wall.
6. On the inside of the shelter, install the wall sleeves in the supply and return air openings. The sleeves may be trimmed to fit flush with the inside wall.
7. Check the fit of each sleeve to its mating flange for possible air leaks. Apply silicone sealer to close any gaps. Install the air return and supply grilles.

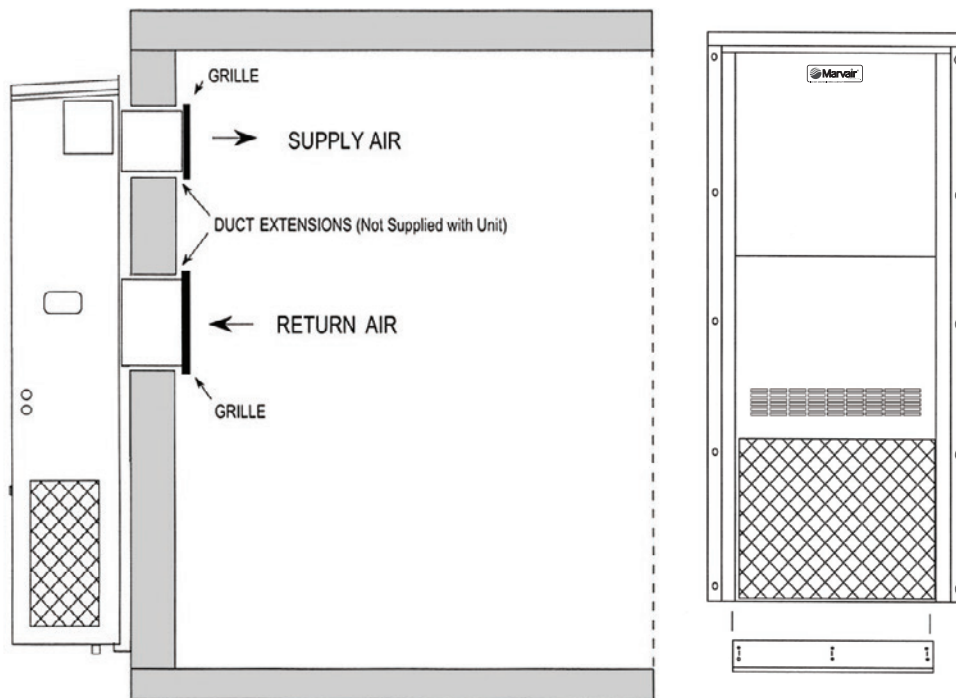

For units with electric heat, a one inch clearance is required around the duct extensions. The duct extensions must be constructed of galvanized steel with a minimum thickness of .019" as per the NFPA standards 90A & 90B.

Figure 5. Eubank A/C Wall Mount Detail

3.8 Electrical Connections

WARNING

ELECTRICAL SHOCK HAZARD

Failure to follow safety warnings exactly could result in serious injury, death, and/or property damage.

Turn off electrical power at fuse box or service panel BEFORE making any electrical connections and ensure a proper ground connection is made before connecting line voltage.

Important

All electrical work must meet the requirements of local codes and ordinances. Work should be done **only** by qualified persons.

Units may incorporate an internal crankcase heater for compressor protection. **The crankcase heater must be energized for at least 24 hours prior to starting the compressor.**

Scroll compressors, like several other types of compressors, will only compress in one rotational direction. The direction of rotation is not an issue with single-phase compressors since they will always start and run in the proper direction. However, three phase compressors will rotate in either direction depending upon phasing of power. Since there is a 50-50 chance of connecting power in such a way as to cause rotation in the reverse direction, it is imperative to confirm that the compressor is rotating in the proper direction at the initial field start-up of the system. Verification of proper rotation is made by observing that the suction pressure drops and the discharge pressure rises when the compressor is energized. An alternate method of verification for self contained system with small critical refrigerant charges, where the installation of gauges may be objectionable, can be made by monitoring the temperature of the refrigerant lines at the compressor. The temperature should rise on the discharge line while the suction line temperature decreases. Reverse rotation also results in a substantially reduced current draw when compared to tabulated values.

There is no negative impact on durability caused by operating three phase compressors in the reversed direction for a short duration of time, usually defined as less than one hour. However, after several minutes of operation the compressor's internal protector will trip. The compressor will then cycle on the protector until the phasing is corrected. Reverse operation for longer than one hour may have a negative impact on the bearings.

To change the rotation, turn off power to the unit and reverse L1 & L2 at the disconnect in the air conditioner.

High Voltage Wiring - (Single Units)

The power supply should have the proper voltage, phase, and ampacity for the selected model.

1. Refer to the electrical data on the data sticker on the unit for field wiring requirements of the unit. Size the incoming power supply lines and the fuse(s) or HACR breaker(s) according to requirements described in the National Electric Code. Run the power conductors through the knockouts on the side or back of the unit. Use appropriate conduit and strain reliefs.

CAUTION

Note: Power supply service must be within allowable range (+10% - 5%) of rated voltage stamped on the unit rating plate. To operate nominal 230/208V unit at 208V, change the transformer line tap from 240V to 208V following the instruction on wiring label in unit.

2. Connect the wires to the input side of the internal breaker or terminal block (L1 & L2 for single-phase units; L1, L2, & L3 for three-phase models).
3. Install the ground wire on the ground lug.
4. For units designed for operation on 208/230V, 60Hz power supply, the transformer is factory wired for a 230V power supply. For a 208V power supply, remove the orange lead from the transformer and connect the red lead. Insulate the orange lead.
5. 460V units have a step down transformer for 230V motors.

⚠ CAUTION

The external breaker(s) that provide power to the air conditioner must be sized per the maximum Fuse Size (MFS) shown on the Unit's data label.

Dual Unit Phasing

For applications where one controller operates two units, e.g., the CommStat 4 or CommStat Touch HVAC controller.

Newer HVAC controllers such as the CommStat do not require unit phasing. However, if other devices are connected to the control system, phasing of the air conditioner is required. Earlier models; i.e., LL357, LL357A, LL357D2 require the unit to be properly phased.

1. Wire each unit as described in steps 1 through 4 above.
2. Test for proper phasing as follows:
 - A. Power up the units.
 - B. Using an AC volt meter set to the 300 volt scale, measure voltage between terminal L1 on the compressor contactor of unit #1 and terminal L1 on the compressor contactor of unit #2. If voltage is present, units are wired out of phase and must be rewired.
 - C. If units are not in phase, turn off power and reverse the field power leads connected to the internal circuit breaker on one of the units only.
 - D. Restore power and retest the phase (step B). When the voltage reads "0", the units are in phase.
 - E. Turn off power and proceed.

Low Voltage Wiring

IMPORTANT. The following instructions are generic wiring instructions and may not be applicable for air conditioners with various options. Always refer to the wiring diagram in the air conditioner for the proper method to wire your unit.

1. On single units, pull the low voltage wiring (e.g., 18 gauge 4-conductor Class 2 thermostat wire) from the unit into the thermostat / subbase assembly. See Figure 9b for connections to various thermostats.
2. Mount the thermostat on the wall of the shelter. The thermostat should be located so that the supply air from the unit does NOT blow directly on to the thermostat. Connect the thermostat to the terminal block in the air conditioner as shown in Figures 9a and 9b.
3. On dual units, refer to the *CommStat Touch, CommStat 4 or CommStat 3 HVAC Controller Specification sheet*. Level and install the controller subbase. Wire the two A/C units to the Lead/Lag Controller, according to the wiring diagram on the specification sheet and as shown in Figure 9c or 9d (note: the diagram also appears on the back cover of the controller).

Remote Signalling: Terminals 5 & 7(N.O.) and 6 & 7 (N.C.) on the terminal board are dry contacts which can be used for remote signalling in the event of a/c cutoff on low or high pressure limit.

Continuous fan operation: For continuous indoor fan operation on single units, install a jumper between terminals 8 and 3. For continuous indoor fan operation on dual units using the older LL357D4, install jumper between 8 and 3 and remove jumper between 1 and 3.

CommStat 4 Lead /Lag Controller

Please refer to the Product Data sheet for the Commstat 4 controller for complete instructions on installing and programming this controller.

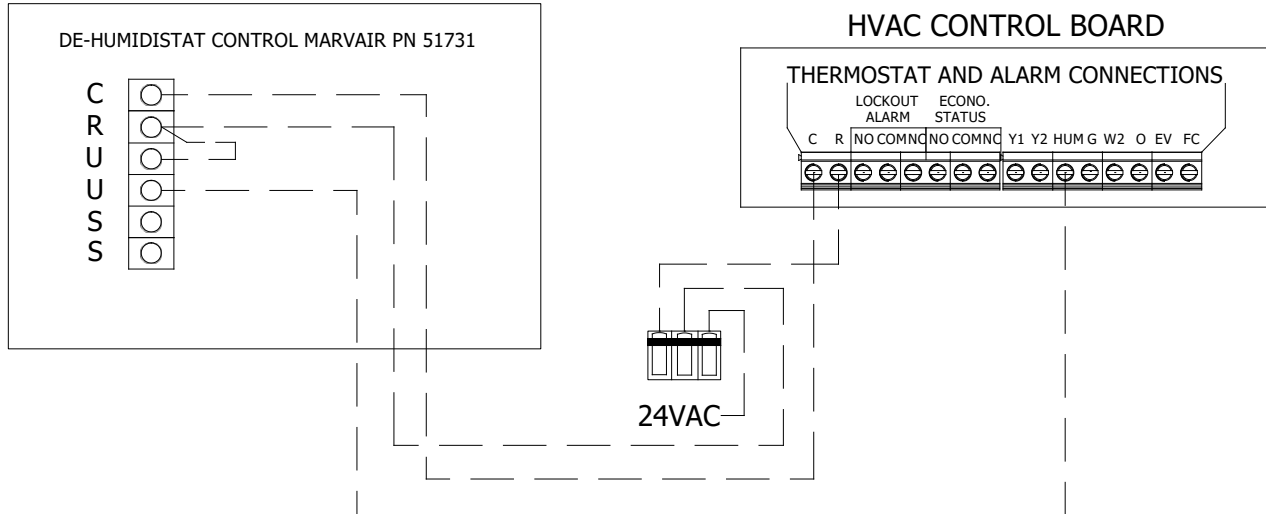

Figure 6a. Humidistat Wiring to a Eubank Air Conditioner with Reheat.

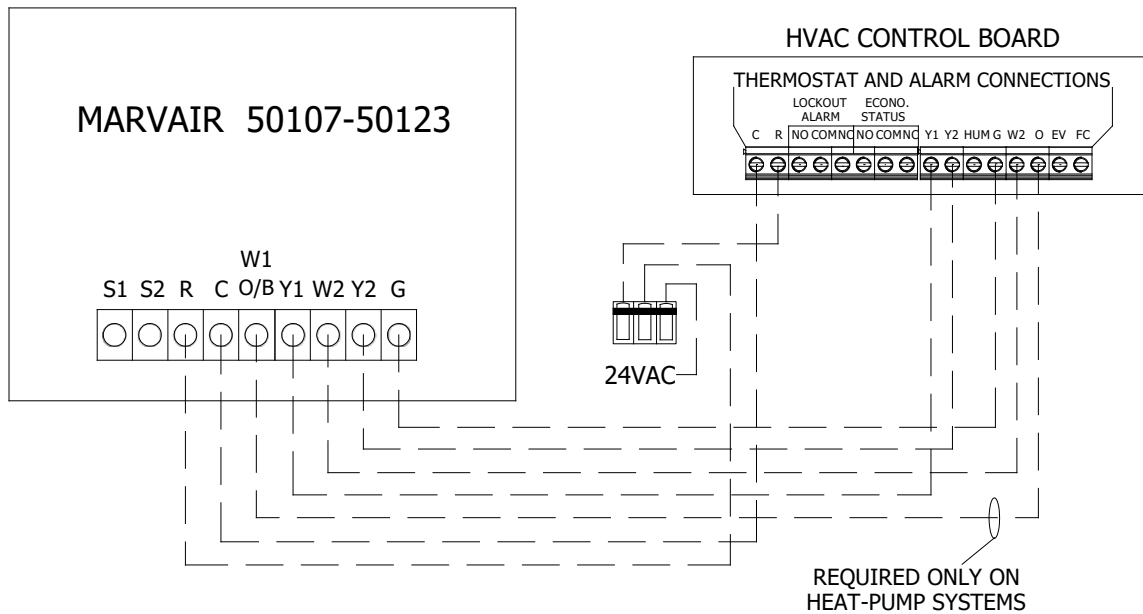
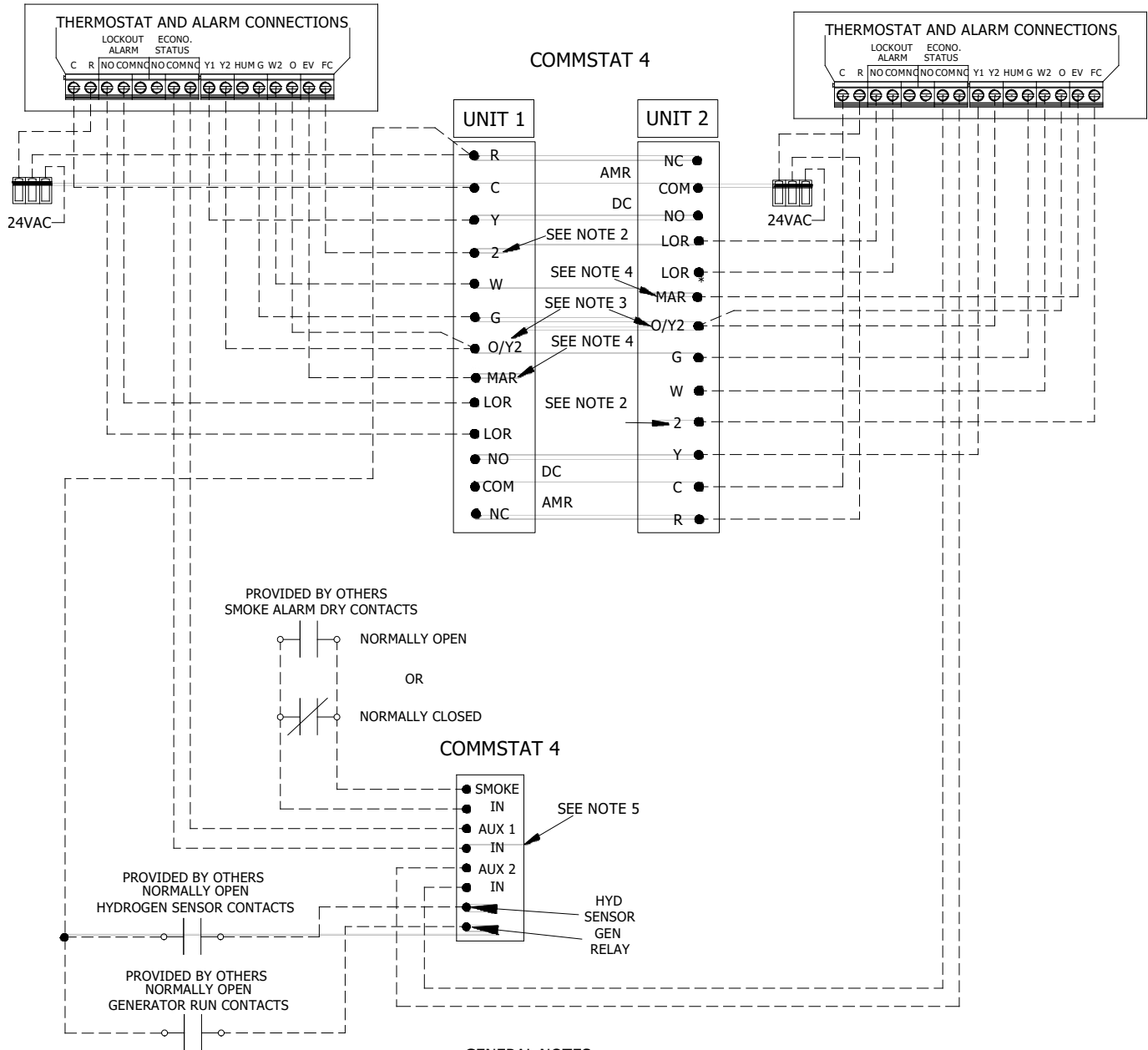

Figure 6b. Thermostat Connection Diagram

HVAC 1 CONTROL BOARD

HVAC 2 CONTROL BOARD



GENERAL NOTES

1. For immediate shutdown of HVAC upon a smoke fault, change setting 3 (Fan Purge) on the HVAC control board to N = No.
2. The CommStat 4 terminal "2" is used to force mechanical cooling if the economizer cooling can't maintain the required cooling demand. This output is only used on systems equipped with economizers.
3. The CommStat 4 terminal "O/Y2" is only used on systems with 2 stage compressors (Y2) or Heat Pumps systems (O).
4. The CommStat 4 terminal "MAR" is only used on systems with economizers. The MAR output forces the system into emergency ventilation mode upon a hydrogen fault.
5. The CommStat 4 "AUX 1" and "AUX 2" terminals are used for economizer status monitoring from the connected HVAC. This feedback is required for the CommStat 4 to override economizer cooling if the economizer and force mechanical cooling if the economizer can't maintain the required cooling demand. These inputs are only used with economizer equipped systems.

Figure 6c. CommStat 4 Wiring Diagram

Chapter 4 Start-Up

4.1 Check-Out of Cooling Cycle

Important: Be sure that the crankcase heater (if used) has been energized for at least 24 hours before starting the unit(s). Double-check all electrical connections before applying power. Eubank air conditioners with scroll compressors running on 3Ø power must be checked for proper rotation during the initial start-up. Please refer to Section 2.8 for determining if the 3Ø compressors are rotating correctly. Incorrect rotation can damage the compressor and is not covered by the warranty

Procedure:

1. Set the cooling set point temperature on the wall thermostat to a point *higher* than the ambient temperature. Set the heating set point temperature to a temperature that is *lower* than the ambient.
2. Set the thermostat system switch in the AUTO position. Nothing should operate at this time.
3. Set the time delay in the electrical control box to three minutes. Check the changeover setting of the enthalpy or dry bulb sensor and reset it if needed (economizer-equipped models only). See Section 1.6.
4. Slowly lower the thermostat's cooling set point temperature until the switch closes. The indoor fan should operate.

Once the indoor fan turns on, allow approximately three minutes for the compressor to start. Note that the outdoor fan may not come on immediately, because it is cycled by refrigerant pressures.

NOTE: (Economizer-Equipped models only) To check the system operation under different ambient conditions, the air temperature and enthalpy sensors must be "tricked". When outdoor ambient conditions are higher than the control setting, a component cooler aerosol may be sprayed directly into the enthalpy sensor to simulate low enthalpy conditions, causing the economizer damper to open.

Alternately, when outdoor conditions are lower than the set point, a source of heat such as a hair dryer can be directed on the air temperature sensor to simulate warmer conditions, which will bring on mechanical cooling and start the compressor.

5. To stop cooling, slowly raise the thermostat cooling set point to a temperature higher than the ambient.

If the unit fails to operate, refer to the troubleshooting information in Chapter 4.

Follow the same procedure for additional units.

NOTE: The fan purge allows the indoor fan to run for approximately 90 seconds after the compressor is off. This operation provides a small improvement in system rated efficiency.

4.2 Check-Out of Heating Cycle

Procedure: (Applies only to units with resistance elements)

1. Raise the heating set point temperature to a setting which is higher than the ambient temperature. The fan and electric heat should immediately cycle on.
2. Move the system switch to the "OFF" position. All functions should stop.

NOTE: (Economizer Equipped models only) The damper blade should remain closed during the heating cycle (unless the minimum position potentiometer has been set for constant ventilation A fully counterclockwise position corresponds to full closure of the damper.

Chapter 5 Troubleshooting

5.1 Overview

A comprehensive understanding of the operation of the air conditioner is a prerequisite to troubleshooting. Please read the Chapter 1 for basic information about the unit.

Eubank air conditioners are thoroughly tested before they are shipped from the factory. Although unlikely, it is possible that a defect may escape undetected, or damage may have occurred during transportation. However, the great majority of problems result from installation errors.

If you experience difficulties with your unit, please review the installation steps in Chapter 2.

Much time can be saved by taking a thoughtful and orderly approach to troubleshooting. Start with a visual check - are there loose wires, crimped tubing, missing parts, etc? Begin deeper analysis only after making this initial inspection.

The troubleshooting information in this manual is basic. The troubleshooting section contains problem/solution charts for general problems, followed by a compressor section.

Not every problem can be anticipated. If you discover a problem that is not covered in this manual, we would be very grateful if you would bring it to the attention of our service department for incorporation in future revisions.

As always, please exercise caution and good judgement when servicing the unit. Use only safe and proven service techniques. Use refrigeration goggles when servicing the refrigeration circuit.

WARNING

The refrigerant circuit has hot surfaces, and the electrical voltages inside of the unit may be hazardous or lethal. SERVICE MAY BE PERFORMED ONLY BY QUALIFIED AND EXPERIENCED PERSONS.

5.2 Failure Symptoms Guide

PROBLEM/SYMPTOM	LIKELY CAUSE(S)	CORRECTION
<p>A. Unit does not run.</p> <p>NOTE: An internal anti-short-cycle timer will prevent the unit from starting for .2 to 8 minutes following start-up.</p>	<ol style="list-style-type: none"> 1. Power supply problem. 2. Tripped internal disconnect. 3. Shut off by external thermostat or thermostat is defective. 4. Unit off on high or low pressure limit. 5. Internal component or connection failure. 	<ol style="list-style-type: none"> 1. Check power supply for adequate phase and voltage. Check wiring to unit and external breakers or fuses. 2. Check internal circuit protection devices for continuity. 3. Check operation of wall-mounted thermostat. 4. Reset pressure switch. 5. Check for loose wiring. Check components for failure.
<p>B. Unit runs for long periods or continuously; cooling is insufficient.</p>	<ol style="list-style-type: none"> 1. Dirty filter or reduced airflow 2. Low refrigerant. 3. Component failure. 4. Unit undersized for job. 	<ol style="list-style-type: none"> 1. Check air filter(s). Check blower operation. Remove airflow restriction. 2. Check for proper charge and possible refrigerant leak. 3. Check internal components, especially compressor for proper operation. 4. Add additional units for greater capacity.
<p>C. Unit cycles on high/low pressure limit.</p>	<ol style="list-style-type: none"> 1. Loss or restriction of airflow. 2. Restriction in refrigerant circuit. 3. Refrigerant overcharge (following field service) 4. Defective pressure control. 	<ol style="list-style-type: none"> 1. Check blower assembly for proper operation. Look for airflow restrictions, e.g., the air filter. Check blower motor and condenser fan. 2. Check for blockage or restriction, especially filter drier and capillary tube assembly. 3. Evacuate and recharge to factory specifications. 4. Check limit cutout pressures. Control is set to actuate at approximately 60 PSIG (low pressure) and 650 PSIG (high pressure)
<p>D. Unit blows fuses or trips circuit breaker.</p>	<ol style="list-style-type: none"> 1. Inadequate circuit ampacity. 2. Short, loose, or improper connection in field wiring. 3. Internal short circuit. Loose or improper connection(s) in unit. 4. Excessively high or low supply voltage or phase loss (3Ø only) 	<ol style="list-style-type: none"> 1. Note electrical requirements in Chapter 2 and correct as necessary. 2. Check field wiring for errors. 3. Check wiring in unit. See wiring and schematic diagrams. Test components (especially the compressor) for shorts. 4. Note voltage range limitations specific to the compressor troubleshooting section.
<p>E. Water on floor near unit.</p>	<ol style="list-style-type: none"> 1. Obstruction in condensate line. 2. Obstruction or leak in condensate pan. 3. Unit is not level. 	<ol style="list-style-type: none"> 1. Check for clog or restriction. 2. Check pan for leak or blockage. 3. Level unit.
<p>F. No space heating or reduced heating (units equipped with resistance elements)</p>	<ol style="list-style-type: none"> 1. Defective heating element(s). 2. Thermal limit open. 3. Defective heater contactor. 	<ol style="list-style-type: none"> 1. Check resistance element(s) for continuity. 2. Check continuity across thermal limit switch. 3. Check relay for proper operation. Replace if defective.

5.3 Compressor Troubleshooting

NOTE: It is important to rule out other component failures before condemning the compressor.

The following electrical tests will aid diagnosis:

1. **Start-Up Voltage:** Measure the voltage at the compressor contactor during start-up. The voltage must exceed the minimum shown in Table 5, section 2.2, or compressor failure is likely. A low voltage condition must be corrected.
 2. **Running Amperage:** Connect a clip-on type ammeter to the (common) lead to the compressor. Turn on the supply voltage and energize the unit. The compressor will initially draw high amperage; it should soon drop to the RLA value or less. If the amperage stays high, check the motor winding resistances.
- NOTE:** Feel the top of the compressor to see if it has overheated. If it is hot, the internal overload may be open. You may have to wait several hours for it to reset.
3. **Motor Winding Resistances:** Using a digital volt-ohm meter (VOM), measure the resistance across the compressor windings as shown below.

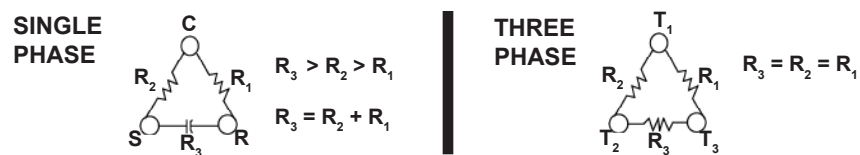

Resistance can be measured as shown above. Any deviation from above values could indicate a defective compressor.

4. **High Voltage/Insulation Test:** Test internal leakage with a megohmmeter. Attach one lead to the compressor case on a bare metal tube and to each compressor terminal to test the motor windings. A short circuit at high voltages indicates a motor defect. Do not do this test under vacuum.
5. On single phase models, check the capacitor by substitution.

5.4 Control Board Diagnosis

The control board (see section 1.6a for a complete description of the control board) has a red diagnostic LED which indicates the lockout fault. The control board will enter into and indicate lockout if either of the fault conditions (LPS or HPS) occur twice.

The contactor must be closed before the first fault condition can be recognized by the control board. The contactor will be closed 3 minutes after the unit is energized and only if cooling is required. The first fault condition will open the contactor and shutdown the unit. The contactor on the unit that has the fault condition must be closed before the second fault condition can be recognized by the control board. The contactor on the unit with the fault condition will close after 3 minutes if the unit is still calling for cooling and if the fault condition no longer exists. If you get a second fault condition, the contactor will open and shutdown the unit. The “red” led will have one blink if the high pressure switch has opened twice and will have two blinks if the low pressure switch has opened twice. The unit must be in the cooling mode (compressor contactor Closed) before a fault condition can occur.

Chapter 6 Maintenance

6.1 Scheduled Maintenance

Eubank strongly recommends that the air conditioner be serviced a minimum of twice a year – once prior to the heating season and once prior to the cooling season. At this time the filters, evaporator coil, condenser coil, the cabinet, and condensate drains should be serviced as described below. Also at this time, the air conditioner should be operated in the cooling and heating cycles as described in Chapter 3, Start-Up. In addition to this seasonal check-out, the AC unit should be maintained as follows:

Air Filter

Replace the air filter whenever it is visibly dirty. Never operate the unit without the filter in place.

Evaporator

If the evaporator becomes clogged or dirty, it may be cleaned by careful vacuuming or with a commercial evaporator cleaning spray. DO NOT use a solvent containing bleach, acetone, or flammable substances. Turn off power before cleaning. Be careful not to wet any of the electrical components. Be sure the unit has dried before restarting.

Condenser

Periodically inspect the outdoor condenser coil and the cabinet air reliefs for dirt or obstructions. Remove foreign objects such as leaves, paper, etc.

If the condenser coil is dirty, it may be washed off with a commercial solvent intended for this purpose. TURN OFF POWER BEFORE CLEANING! Be sure that all electrical components are thoroughly dry before restoring power. Use a fin comb of the correct spacing to straighten mashed or bent fins.

Cabinet

The cabinet may be cleaned with a sponge and warm, soapy water or a mild detergent. Do not use bleach, abrasive chemicals or harmful solvents.

Drains

Regularly check the primary and secondary condensate drains. The secondary drain has a stand pipe. An obstruction will force water to dump into the middle of the unit and drain out the sides of the unit, causing discoloration of the side panels. If discoloration is noted, service the drains.

If a commercial drain solvent is used, flush out the drain pan and system with plenty of fresh water to prevent corrosion.

Lubrication

Oiling of the condenser fan motor or the evaporator blower motor is not recommended.



Sever hazard. The economizer contains moving parts capable of causing serious injury or death. Disconnect power before removing the covering panel.

Chapter 7 Warranty

7.1 Marvair, Inc. Limited Product Warranty

Marvair Inc., warrants its products to be free from defects in materials and workmanship under normal use to the original purchaser for the period of time in the table below. If any part of your product fails within 12 months from start-up, or 18 months from shipment from the factory, whichever comes first, Marvair, Inc. will furnish without charge, EXW Cordele, Georgia, the required replacement part. The owner must provide proof of the date of the original start-up. The contractor's invoice, the certificate of occupancy, or similar documents are examples of acceptable proof of the date of the original start-up.

Marvair, ICE, Eubank Products
90 Days ¹ w/Flat Rate Labor ² (See <i>Marvair, ICE, Eubank Flat Rate Labor Guidelines</i>)
1 Year Parts ^{2,3}
5 Years Compressor ²

¹If any part of your Marvair, Inc. unit fails within 90 days of the commencement of the warranty, Marvair, Inc. will furnish without charge, EX Works, Cordele, Georgia, the required replacement part and pay for the labor to replace the part in accordance with the Marvair, Inc. Flat Rate Labor Guidelines.

²All OTR (over the road) applications that are moved from one location to another: Factory Warranty applies only up to the point of initial start-up and test at all OEM manufacturing locations or subsequent facility. Once it goes into OTR service, the warranty expires immediately for compressor and sealed system components. This OTR exemption does not apply to relocatable classrooms, construction or office trailers.

³All warranty replacement parts shall be shipped Ground only. Expedited shipping is available upon request for additional cost.

The responsibility of the equipment owner includes:

1. To operate the equipment in accordance with the manufacturer's instructions.
2. To provide easy accessibility for servicing.
3. To check and reset any circuit breaker(s) and/or disconnect(s) prior to calling for service.
4. To keep the unit clean and free of dirt and containment and replace filters as required.
5. To keep the outdoor coil clean and free of leaves, paper, or other debris.
6. To pay the charges incurred when any of the above have not been done.
7. To pay for repair or replacement of any material or part other than those within the Marvair unit or controller.

Marvair, Inc., will not be responsible for labor after 90 days, transportation costs, delays or failures to complete repairs caused by events beyond our control (labor hours incurred due to required site-specific training, time waiting to gain access, or extended drive time for remote sites). This warranty does not cover:

1. Any transportation, related service labor, diagnosis calls, filter, driers, refrigerant, or any other material charges.
2. Damages caused by shipping, accident, abuse, negligence, misuse, fire, flood, or Acts of God.
3. Damages caused by operating or staging the unit in a corrosive environment.
4. Damages caused by improper application of the product.
5. Damages caused by failing to perform proper routine maintenance.
6. Expenses incurred for erecting, disconnecting or dismantling the product or installing the replacement part(s).
7. Products not installed or operated according to the included instructions, local codes, and good trade practices.
8. Products moved from the original installation site.
9. Products lost or stolen
10. Consequential damages or incidental expenses including losses to persons, property or business.
11. Modifications to original unit after it leaves the factory, such as breaking into any part of the sealed systems unless authorized in advance in writing by Marvair, Inc..
12. Damages as a result of operating as a construction site cooler / dehumidifier.

When labor (first 90 days only) is required, it must be performed during normal working hours (8:00 AM - 5:00 PM) Monday - Friday and must be performed by Marvair, Inc., personnel or a designated Service Representative.

The owner of the product may ship the allegedly defective or malfunctioning product or part to Marvair, Inc., at such owner's expense, and Marvair, Inc., will diagnose the defect and, if the defect is covered under this warranty, Marvair, Inc., will honor its warranty and furnish the required replacement part. All costs for shipment and risk of loss during shipment of the product to Marvair, Inc., and back to the owner shall be the responsibility and liability of the owner. Upon written request by an owner, Marvair, Inc., may arrange for remote diagnosis of the allegedly defective or malfunctioning product or part but all costs for transportation, lodging and related expenses with regard to such diagnostic services shall be the responsibility and liability of the owner.

An owner requesting performance under this Warranty shall provide reasonable access to the allegedly defective or malfunctioning product or part to Marvair, Inc., and its authorized agents and employees.

THIS WARRANTY CONSTITUTES THE EXCLUSIVE REMEDY OF ANY PURCHASER OF A MARVAIR HEAT PUMP OR AIR CONDITIONER AND IS IN LIEU OF ALL OTHER WARRANTIES, EXPRESSED OR IMPLIED, INCLUDING, WITHOUT LIMITATION, ANY IMPLIED WARRANTY OF MERCHANTABILITY OR FITNESS FOR USE, TO THE FULLEST EXTENT PERMITTED BY LAW. IN NO EVENT SHALL ANY IMPLIED WARRANTY OF MERCHANTABILITY OR FITNESS FOR USE EXCEED THE TERMS OF THE APPLICABLE WARRANTY STATED ABOVE AND MARVAIR SHALL HAVE NO OTHER OBLIGATION OR LIABILITY. IN NO EVENT SHALL MARVAIR BE LIABLE FOR INCIDENTAL OR CONSEQUENTIAL DAMAGES OR MONETARY DAMAGES.

THIS WARRANTY GIVES YOU SPECIFIC LEGAL RIGHTS, AND YOU MAY ALSO HAVE OTHER RIGHTS WHICH VARY FROM STATE-TO-STATE. Some states do not allow limitations or exclusions, so the above limitations and exclusions may not apply to you.

Chapter 8 Start-Up Check List

8.1 Start-Up & Commissioning Form

Please complete the information on this form and return to Eubank by mail or fax. The mailing address and fax number can be found at the end of the form.

A. Equipment Information

Date: _____ Equipment Owner _____

Installing Company: _____ Installer: _____

Address: _____ State _____

City: _____

ICE Air conditioner: Model No. _____

Serial No. _____

Compressor: Model No. _____

Serial No. _____

Compressor: Model No. _____

Serial No. _____

B. Pre-Start Up

Is there any shipping damage? Yes No

If so, where? _____

Will this damage prevent starting the unit? Yes No

Check Power Supply, does it agree with data sticker on air conditioner? Yes No

Has the ground wire been connected? Yes No

Has the circuit protection been sized and installed properly? Yes No

Controls

Are the thermostat control wiring connections made and checked? Yes No

Are all wiring terminals (including main power supply) tight? Yes No

If unit has a crankcase heater, has it been energized for 24 hours? Yes No

On a 208/230 v. units is control transformer (24 AC) wired for correct voltage? Yes No

Condensate Section

Has water been placed in drain pan to confirm proper drainage? Yes No

Are correct filters in place? Yes No

Refrigerant Piping

If leaks are found, report any leaks to Marvair Warranty Service Dept.

C. Check Rated Voltage at Terminal Block for Imbalance before starting of Unit.

- 208/230V 1 Phase 208/230V 3 Phase 460V 3 Phase
380V 3 Phase 50Hz. 575 3 Phase 60 Hz.

Measured Line to Line Volts L1&L2 _____ V. L1&L3 _____ V. L2&L3 _____ V.

$(L1\&L2 + L1\&L3 + L2\&L3)/3 = \text{Avg. Voltage} = \underline{\hspace{2cm}}$

Max. Deviation from avg. voltage = _____ volts

Voltage imbalance = $(100 \times \text{Max. Deviation})/\text{avg. Voltage} = \underline{\hspace{2cm}}\%$

A voltage deviation greater than 2% with the unit running should be addressed and corrected. Excess voltage deviation can cause the compressor to overheat and to operate inefficiently.

Example:
$$\frac{\text{Maximum Deviation from Average Voltage} \times 100}{\text{Average voltage}} \text{ (for Percent)}$$

Measured Voltages:

- L1 & L2 = 241 Volts
- L1 & L3 = 243 Volts = $717 / 3 = 239$ Average Voltage
- L2 & L3 = 233 Volts

$239 - 233 = 6$
 $100 \times 6/239 = 2.5\%$ Voltage Unbalance

Three phase units only check fan & compressor rotation.

D. Heating Mode Check & Record Readings

	Circuit 1	Circuit 2 <i>(if applicable)</i>
Room Temperature	_____	_____
Outside Temperature	_____	_____
Evap. Entering Air DB Temp	_____	_____
Evap. Entering Air WB Temp	_____	_____
Evap. Leaving Air DB Temp	_____	_____
Evap. Leaving Air WB Temp	_____	_____
Heater Contactor Amps (L1)	_____	_____
Heater Contactor Amps (L2)	_____	_____
Heater Contactor Amps (L3)	_____	_____

E. Cooling Mode Check & Record Refrigerant Pressures

Recheck voltage imbalance in cooling mode:

Measured Line to Line Volts L1&L2 _____ V. L1&L3 _____ V. L2&L3 _____ V.

$(L1\&L2 + L1\&L3 + L2\&L3)/3 = \text{Avg. Voltage} = \underline{\hspace{2cm}}$

Max. Deviation from avg. voltage = _____ volts

Voltage imbalance = $(100 \times \text{Max. Deviation})/\text{avg. Voltage} = \underline{\hspace{2cm}}\%$

APPENDIX A: Installation Instructions for Field Installed Electric Heat, Models 1024-1072

WARNING FIRE HAZARD

Improper adjustment, alteration, service, maintenance or installation could cause serious injury, death and/or property damage.

Installation or repairs made by unqualified persons could result in hazards to you and others. Installation **MUST** conform with local codes or, in the absence of local codes, with codes of all governmental authorities have jurisdiction.

The information contained in this manual is intended for use by a qualified service agency that is experienced in such work, is familiar with all precautions and safety procedures required in such work, and is equipped with the proper tools and test instruments.

Duct Work

General Information

Note: The following instructions are for general guidance only. Due to the wide variety of installation possibilities, specific instructions will not be given. When in doubt, follow standard and accepted installation practices, or contact Eubank for additional assistance.

Wall Openings

Measure the dimensions of the supply and return ports on the unit.

Cut the openings in the exterior wall for the supply and return. **IMPORTANT: All units with electric heat must have 1" (25.4 mm) clearance on all four sides of the supply outlet duct flange on the unit. The 1" (25.4 mm) clearance must extend on all sides of the supply duct for the first 3 feet (1 meter) from the unit.**

IMPORTANT: Eubank requires a minimum of 1" (25.4 mm) from the surface of any supply ducts to combustible material for the first 3 feet (1 meter) of the duct.

Ducting

Extensions should be cut flush with the inside wall for applications without duct work.

Applications using duct work should be designed and installed in accordance with all applicable safety codes and standards. Eubank strongly recommends referring to the current edition of the National Fire Protection Association Standards 90A and 90B before designing and installing duct work. The duct system must be engineered to insure sufficient air flow through the unit to prevent over-heating of the heater element. This includes proper supply duct sizing, sufficient quantity of supply registers, adequate return and filter area. Ductwork must be of correct material and must be properly insulated. Duct work must be constructed of galvanized steel with a minimum thickness of .019 inches for the first 3 feet (1 meter). Ductwork must be firmly attached, secured and sealed to prevent air leakage. Do not use duct liner on inside of supply duct within 4 feet (122 cm) of the unit. Galvanized metal duct extensions should be used to simplify connections to duct work and grilles. Use fabric boots to prevent the transmission of vibration through the duct system. The fabric must be U.L. rated to a minimum of 197°F (92°C).

 **WARNING**

ELECTRICAL SHOCK HAZARD

Failure to follow safety warnings exactly could result in serious injury, death, and/or property damage.

Turn off electrical power at fuse box or service panel BEFORE making any electrical connections and ensure a proper ground connection is made before connecting line voltage.

Heater installation (see drawings and wiring diagram)

1. Remove top front panel.
2. Remove bottom front panel.
3. Remove the control box cover.
4. Remove the heater access cover plate on the upper right side of the unit by removing the three screws. Cut insulation on two sides and fold down out of way.
5. Slide new heater assembly into place by lining up stem with hole on far end. Make sure stem of new heater assembly is inserted into correct hole. The hole nearest to the indoor coil is for three element heaters and the farthest away from indoor coil is for all other heaters.
6. Install the two No. 10 screws in the heater assembly plate.
7. Install wire harness in hole provided in drain pan and then through filter bracket and then into control box.
8. Wire the heater as shown in the wiring diagram provided with the heater kit (the insulated terminal ends are to be connected at the heater)
9. Install pop tie in appropriate hole in back panel to secure wire.
10. Install closed cell strip around wires where they pass through the drain pan.
11. Reinstall the heater access cover.
12. Mount the heat contactor inside the control box where the mounting holes are provided for the heat contactor.
13. Make the wiring connections inside the control box as shown in the wiring diagram provided with the heater kit. Bundle loose wires with wire ties.
14. With a permanent marker, place an (X) in the space provided next to the heater kit rating of the installed heater on the unit data label.
15. Place the wiring diagram provided with the heater kit inside the zip lock bag which is affixed to the back side of the control box cover.
16. Replace the control box cover, the bottom front cover and the top front panel.

