

CP / CE SERIES SOFFIT MOUNT AIR HANDLER

Job: _____	Engineer: _____
Location: _____	Architect: _____
Schedule No.: _____	Date: _____
System Designation: _____	For: _____

FEATURES

- Available in uncased or factory-installed cased configurations.
- Designed for installation in a furred down area
- Fits industry standard footprints
- Optional field or factory installed heat 3-10kW
- Optional factory installed TXV w/threaded connections

Product Warranty

- 10-year limited warranty available
- Product registration required

Optional Accessories

- Decorative panel
- Heat pump relay
- Float switch

Physical Data

	Unit Size														
	CP18	CE18	CP19	CE19	CP23	CE23	CP24	CE24	CP25	CE25	CP29	CE29	CP30	CE30	
Available Voltages	208/240 V, 60 Hz, 1 Phase														
Maximum Elec. Heat available (kW)	8	8	8	8	8	8	10	10	10	10	10	10	10	10	
Transformer Size and Type	40VA, Class 2														
Blower Data: 2-Speed PSC Motor	Motor H.P.	1/8	--	1/8	--	1/3	--	1/3	--	1/3	--	1/3	--	1/3	--
	F.L.A. @ 240 V	1.25	--	1.25	--	1.9	--	1.9	--	1.9	--	1.9	--	1.9	--
Blower Data: ECM Constant Torque	Motor H.P.	--	1/4	--	1/4	--	1/4	--	1/4	--	1/4	--	1/4	--	1/4
	F.L.A. @ 240 V	--	2	--	2	--	2	--	2	--	2	--	2	--	2
Nominal CFM	600	600	600	600	800	800	800	800	800	800	1000	1000	1000	1000	
Refrigerant Conn. (IDS) Suction	3/4"														
Refrigerant Conn. (IDS) Liquid	3/8"														
R-410A Piston Size (in)	0.049	0.049	0.049	0.049	0.053	0.053	0.053	0.053	0.053	0.053	0.059	0.059	0.059	0.059	
Pallet Quantity (min order per model)	8														
Max Unit Weight (uncased)	60	63	65	68	63	63	65	68	70	73	68	70	70	73	
Max Shipping Weight (uncased)	63	66	68	71	66	66	68	71	73	76	71	73	73	76	
Max Unit Weight (cased)	89	92	97	100	92	92	97	100	105	108	103	105	105	108	
Max Shipping Weight (cased)	92	95	100	103	95	95	100	103	108	111	106	108	108	111	

NOTES:

Cooling capacities subject to outdoor unit matchup. See <http://www.adpnow.com/extratratings/> for individual capacities by OEM

Cooling and Heating capacity data is rated at the following conditions:

Cooling: 80 FDB / 67 FWB Indoor, 95 FDB Outdoor

Heating: 70 FDB / 47 FWB Indoor, 43 FDB Outdoor



Product improvement is a continuous process at Advanced Distributor Products. Therefore, product specifications are subject to change without notice and without obligation on our part. Please contact your ADP representative or distributor to verify details.

© by **Advanced Distributor Products**. All rights reserved.

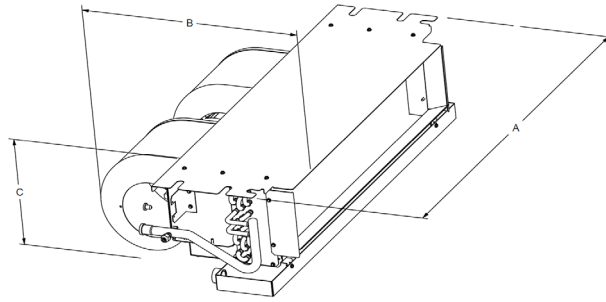
SUBMITTAL DATA
CP SERIES SOFFIT MOUNT AIR HANDLER

Uncased Dimensions					
Air Handler Size	A (in)	B (in)	C (in)	D (in)	E (in)
18, 23	37	19.5	10.5	34.5	34.7
19, 24, 29	43	20.5	10.5	40.5	40.7
25, 30	49	20.5	10.5	46.5	46.7

Cased Dimensions					
Air Handler Size	A (in)	B (in)	C (in)	D (in)	E (in)
18, 23	39.7	24	11	30.5	7
19, 24, 29	45.7	24	11	36.5	7
25, 30	51.7	24	11	42.5	7

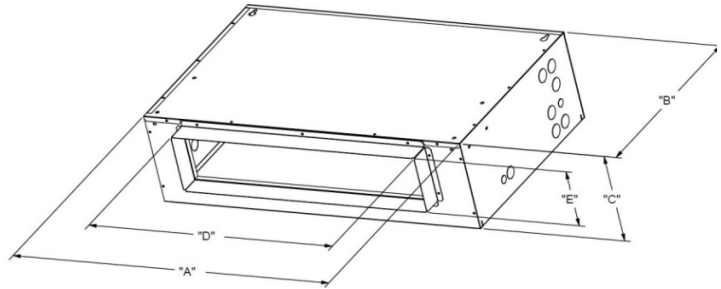
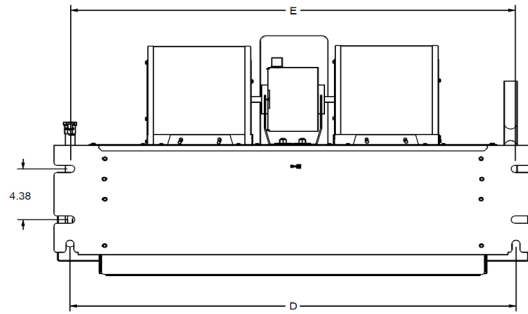
2-Speed PSC Motor

Airflow						
Unit Size	Cooling Speed Setting	Airflow (CFM) vs. External Static Pressure (inches W.C.) ***				
		0.1	0.2	0.3	0.4	0.5
18	Low - Red	610	536	468	392	316
	* ^ High - Black	680	607	532	456	368
23	Low - Red	846	777	702	627	546
	* ^ High - Black	902	830	755	667	589
24, 29	Low - Red	833	781	725	658	580
	* ^ High - Black	1039	976	903	825	728
25, 30	Low - Red	839	771	706	644	553
	* ^ High - Black	1050	975	901	820	744

* Factory setting for cooling.

^ Factory setting for heating.

*** All airflow data is with a dry coil & electric heat.

ECM Constant Torque Motor

Airflow						
Unit Size	Blower Speed Setting	Airflow (CFM) vs. External Static Pressure (inches W.C.) ***				
		0.1	0.2	0.3	0.4	0.5
18, 19	Tap 1 (G)	604	514	453	437	301
	Tap 2 (DS)	604	514	453	437	301
	Tap 3 (Y1)	735	651	577	506	444
	Tap 4 (Y2)	890	826	764	700	605
	^ Tap 5 (W1)	890	826	764	700	605
23, 24, 29	Tap 1 (G)	618	547	464	344	270
	Tap 2 (DS)	617	547	469	351	273
	Tap 3 (Y1)	779	720	633	549	441
	Tap 4 (Y2)	940	876	812	750	675
	^ Tap 5 (W1)	937	875	812	750	674
25, 30	Tap 1 (G)	630	557	485	380	277
	Tap 2 (DS)	630	556	483	378	277
	Tap 3 (Y1)	803	719	640	576	521
	Tap 4 (Y2)	981	909	833	766	705
	^ Tap 5 (W1)	984	909	837	769	709

^ Factory setting for heating.

*** All airflow data is with a dry coil & electric heat.

Electrical

Unit Size (All have electric heat)	Heating Capacity		Blower Amps				Minimum Circuit Ampacity				MOCP
	kW	BTUH	PSC		ECM		PSC		ECM		
			208 V	240 V	208 V	240 V	208 V	240 V	208 V	240 V	
	240 V ^[1]	240 V ^[1]									
18, 19	3.0	10236	1.25	1.25	2.00	2.00	15.1	17.2	16.0	18.1	30
	5.0	17060	1.25	1.25	2.00	2.00	23.2	26.6	24.1	27.5	30
	6.0	20472	1.25	1.25	2.00	2.00	28.6	32.8	29.5	33.8	45
	8.0	27296	1.25	1.25	2.00	2.00	37.6	43.2	38.5	44.2	45
23, 24, 29	3.0	10236	1.9	1.9	2.00	2.00	15.9	18.0	16.0	18.1	30
	5.0	17060	1.9	1.9	2.00	2.00	24.0	27.4	24.1	27.5	30
	6.0	20472	1.9	1.9	2.00	2.00	29.4	33.6	29.5	33.8	45
	8.0	27296	1.9	1.9	2.00	2.00	38.4	44.0	38.5	44.2	45
	10 ^[2]	34120	1.9	1.9	2.00	2.00	41.4	54.4	41.6	54.5	60
25, 30	5.0	17060	1.9	1.9	2.00	2.00	24.0	27.4	24.1	27.5	30
	6.0	20472	1.9	1.9	2.00	2.00	29.4	33.6	29.5	33.8	45
	8.0	27296	1.9	1.9	2.00	2.00	38.4	44.0	38.5	44.2	45
	10.0	34120	1.9	1.9	2.00	2.00	41.4	54.4	41.6	54.5	60

[1] For 208 Volts use .751 correction factor for kW & MBTUH.

[2] 10kW not available in -23 model