

SPLIT SERIES

# INSTALLATION

MANUAL

ISO 9001:2000 Certified

## TABLE OF CONTENTS

Model Nomenclature ..... 1

Initial Inspection ..... 2

Moving and Storage ..... 2

Safety Considerations ..... 2

General Description ..... 2

**Location:**

Condensing Section ..... 2

Air Handler ..... 2

**Installation:**

Condensing Section ..... 3

Air Handler ..... 3

Condensate Drain ..... 3

Duct System ..... 3

Electrical ..... 4

Low Voltage Control Wiring ..... 4

Water Piping ..... 5

Refrigerant Lines ..... 6

General Information ( Refrigerant Lines ) ..... 6

Linear vs. Equivalent Line Length ..... 6

Connecting Refrigerant Lines ..... 6

Charging the System ..... 7

Things to Remember ( Refrigerant Lines ) ..... 7

Line Sizing Charts ..... 7

Examples ( Line Sizing ) ..... 8

In-Warranty Material Return ..... 9

System Checkout ..... 9

Unit Start-up ..... 9

Wiring Diagrams ..... 10

Trouble Shooting ..... 17

### MODEL NOMENCLATURE

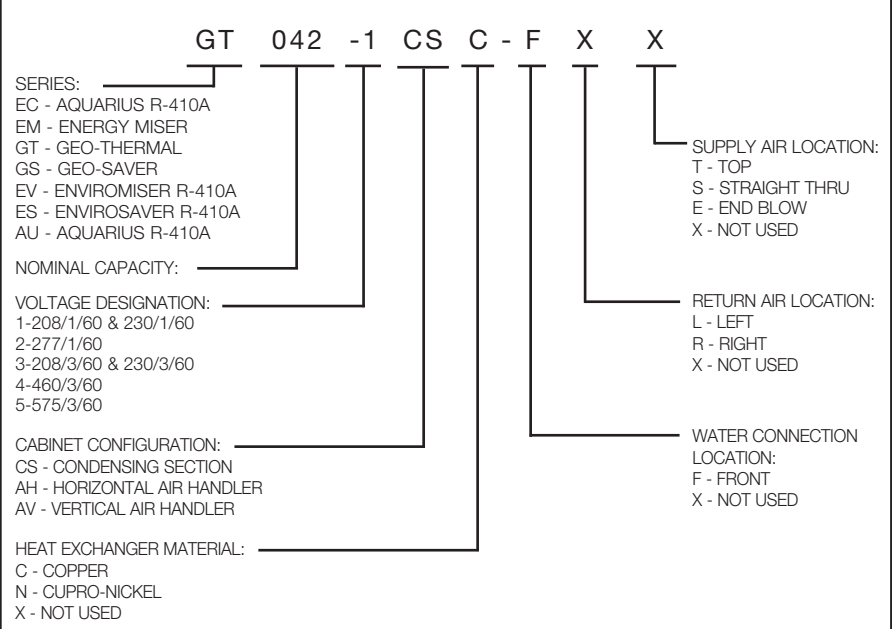

**INITIAL INSPECTION:**

Be certain to inspect all cartons or crates on each unit as received at the job site before signing the freight bill. Verify that all items have been received and that there are no visible damages; note any shortages or damages on all copies of the freight bill. In the event of damage or shortage, remember that the purchaser is responsible for filing the necessary claims with the carrier. Concealed damages not discovered until after removing the units from the packaging must be reported to the carrier within 24 hours of receipt.

**GENERAL DESCRIPTION:**

Split system heat pumps provide the best combination of performance and efficiency available. They are Underwriters Laboratories (UL) listed and certified for safety. Safety devices are built into each unit to provide the maximum system protection possible when properly installed and maintained.

Split system heat pumps consist of two independently installed sections allowing for centralized air distribution while remotely locating the section containing the compressor and water-to-refrigerant heat exchanger. In the cooling mode, the air coil in the air handler section serves as an evaporator and the water-to-refrigerant heat exchanger serves as a condenser. In the heating mode, their roles are reversed. The refrigerant lines connecting the two sections consist of one line carrying liquid refrigerant and another carrying refrigerant vapor. The liquid carrying line will be referred to as the liquid line while the vapor carrying line will be referred to as the suction line.

**WARNING:** This product should not be used for temporarily heating/cooling during construction. Doing so may effect the units warranty.

**MOVING AND STORAGE:**

If the equipment is not needed for immediate installation upon its arrival at the job site, it should be left in its shipping carton and stored in a clean, dry area. Units must only be stored or moved in the normal upright position as indicated by the "UP" arrows on each carton at all times.

**SAFETY CONSIDERATIONS:**

Installation and servicing of this equipment can be hazardous due to system pressure and electrical components. Only trained and qualified personnel should install, repair, or service the equipment. Untrained personnel can perform basic functions of maintenance such as cleaning coils and replacing filters.

**WARNING:** Before performing service or maintenance operations on the system, turn off main power to the unit. Electrical shock could cause personal injury or death.

When working on equipment, always observe precautions described in the literature, tags, and labels attached to the unit. Follow all safety codes. Wear

safety glasses and work gloves. Use a quenching cloth for brazing, and place a fire extinguisher close to the work area.

**LOCATION:**

To maximize system performance, efficiency and reliability, and to minimize installation costs, it is always best to keep the refrigerant lines as short as possible. Every effort should be made to locate the air handler and the condensing section as close as possible to each other.

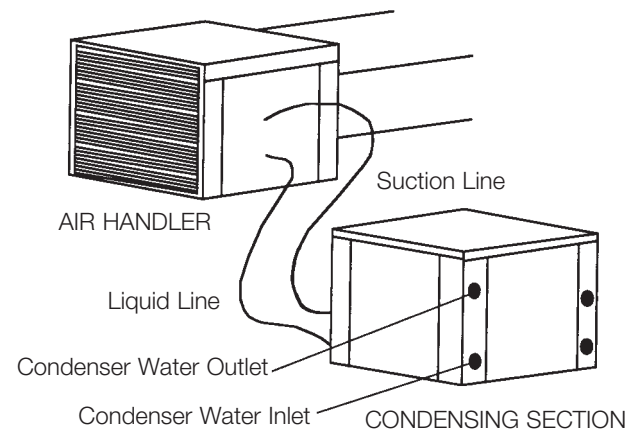

( Figure #1 )

**CONDENSING SECTION:**

Locate the condensing section in an area that provides sufficient room to make water and electrical connections, and allows easy removal of the access panels, for service personnel to perform maintenance or repair.

The condensing section is designed for outdoor use; however, if the condensing section must be installed in a location where ambient temperatures can fall below freezing, some form of freeze protection should be employed such as a freeze-stat and/or a pump timer/starter to prevent possible condenser freeze-up and to optimize overall system performance. Consult the factory in these instances for guidance.

**WARNING:** Water freezes at 32°F. Frozen water coils are not covered under the limited product warranty. It is the installers responsibility to insure that the condensing section is installed in a location or has the proper controls to prevent rupturing the water coil due to freezing conditions.

**AIR HANDLER:**

Locate the air handler unit in an indoor area that allows easy removal of the filter and access panels, and has enough room for service personnel to perform maintenance or repair. Provide sufficient room to make electrical and duct connections. If the unit is located in a confined space such as a closet, provisions must be made for return air to freely enter the space. On horizontal units, allow adequate room below the unit for a condensate drain trap. The air handler units are

not approved for outdoor installation; therefore, they must be installed inside the structure being conditioned.

## INSTALLATION:

**NOTE:** The installer should comply with all local codes and regulations which govern the installation of this type of equipment. Local codes and regulations take precedent over any recommendations contained in these instructions. In lieu of local codes, the equipment should be installed in accordance with the recommendations made by the National electric code, and in accordance with the recommendations made by the National Board of Fire Underwriters.

## CONDENSING SECTION:

The condensing section should be mounted on a vibration absorption pad on a cement slab or similar support to provide a good base and some degree of levelness. The cement pad should not come in contact with the foundation or side of the dwelling, because sound may be transmitted into the residence.

**NOTE:** Do not remove the protective caps or plugs from the service valves until the refrigerant lines are run and ready for final connection.

## AIR HANDLER:

The air handler section may be installed on any level surface strong enough to support its weight. When installed in a closet or on a base stand, it should be mounted on a vibration absorbing pad slightly larger than the base to minimize vibration transmission to the building structure.

When installed in an attic or above a drop ceiling, the installation must conform to all local codes. When installed in the horizontal position (supply air at the end or side of the unit), the unit should be supported on all four corners with threaded rods attached to the building ceiling rafters and utilizing the hanger kits. Refer to the hanging bracket assembly and installation instructions for details.

Some applications require an attic floor installation of the air handling unit. In this case the unit should be set in a full size secondary drain pan on top of a vibration absorbing mesh. The secondary drain pan prevents possible condensate overflow or water leakage damage to the ceiling. The secondary drain pan is usually placed on a plywood base isolated from the ceiling joists by additional layers of vibration absorbing mesh. In both cases, a 3/4" drain connected to this secondary pan should be run to an eave at a location that will be noticeable.

If the air handler is located in a crawl space, the bottom of the unit must be at least 4" above grade to prevent flooding of the electrical parts due to heavy rains.

## CONDENSATE DRAIN:

The air handler should be pitched approximately 1/4" towards the drain in both directions, to facilitate condensate removal. A drain line must be connected to the air handler and pitched away from the unit a minimum of 1/8" per foot to allow the condensate to flow away from the unit. This connection must be in conformance with local plumbing codes. A trap must be installed in the condensate line to insure free condensate flow. (Units are not internally trapped). A vertical air vent is sometimes required to avoid air

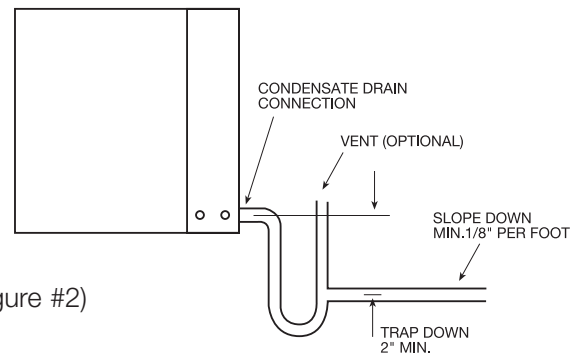

(Figure #2)

pockets. (See Figure #2). The length of the trap depends on the amount of positive or negative pressure on the drain pan. A second trap must not be included.

## DUCT SYSTEM:

All air handlers are provided with supply air outlet collars and return air duct flanges to facilitate duct connections. Refer to the individual data specification sheet for physical dimensions of the collar and flange.

A flexible connector is recommended for supply and return air connections on metal duct systems to isolate vibration and noise from the building structure. All metal ducting should be insulated with a minimum of one-inch duct insulation to avoid heat loss or gain and prevent condensate forming during the cooling operation. Application of the unit to uninsulated duct work is not recommended as the unit's performance will be adversely affected. Do not connect discharge ducts directly to the blower outlet. The factory provided air filter must be removed when using a filter back return air grill. The factory filter should be left in place on a free return system.

If the air handler will be installed in a new installation with new duct work, the installation should be designed using current ASHRAE procedures for duct sizing. If the air handler will be connected to an existing duct system, a check should be made to assure that the duct system has the capacity to handle the air required for the unit application. If the duct system is too small, larger duct work must be installed. Be certain to check for existing leaks and repair.

The duct system and all diffusers should be sized to handle the designed air flow quietly. To maximize sound attenuation of the unit blower, the supply and return air plenums should be insulated. There should be no direct straight air path thru the return air grille

into the air handler. The return air inlet to the air handler must have at least one 90 degree turn away from the space return air grille. If air noise or excessive air flow are a problem, the blower speed can be changed to a lower speed to reduce air flow.

### ELECTRICAL:

**WARNING:** Always disconnect power to the unit before servicing to prevent injury or death due to electrical shock or contact with moving parts.

All field wiring must comply with local and national fire, safety and electrical codes. Power to the unit must be within the operating voltage range indicated on the unit's nameplate. On three phase units, phases must be balanced within 2%.

**CAUTION:** Operating the unit with improper line voltage or with excessive phase imbalance is hazardous to the unit and constitutes abuse and is not covered under warranty.

Properly sized fuse or HACR circuit breakers must be installed for branch circuit protection. See equipment rating plates for maximum size.

Both the indoor and outdoor units are supplied with an opening for attaching conduit. Flexible wiring and conduit should be used to isolate vibration and noise from the building structure. Be certain to connect the ground lead to the ground lug in each of the control boxes. Connect the power leads as indicated on the unit wiring diagrams.

### LOW VOLTAGE CONTROL WIRING

#### AU, EC, EV, EM, and GT Series without Electric Heat

On the above series units the thermostat wiring connections are made at the air handling section. FHP recommends the use 18 gauge, 7 wire solid copper thermostat conductive cables.

This will allow the capability to utilize both the condensate overflow switch and the alarm output options if ordered.

FHP recommends the use of 18 gauge 7 wire solid copper thermostat conductive cable to wire from the condensing section terminal strip to the air handler terminal strip. Typical wiring diagrams are shown for both the air handler and the condensing sections.

Three phase control wiring is the same as single phase control wiring

Connection point logic is as follows:

| From Thermostat  | To Air Handler    | To Condensing Section |
|------------------|-------------------|-----------------------|
| C                | C                 | C                     |
| R                | R                 | R                     |
| G                | G                 |                       |
| O <sup>(3)</sup> | O                 | O                     |
| Y/Y1             | Y/Y1              | Y/Y1                  |
| Y2               | Y2                | Y2                    |
|                  | CS <sup>(1)</sup> | CS <sup>(1)</sup>     |
| L <sup>(2)</sup> | Splice            | ALR <sup>(2)</sup>    |

### NOTES:

- 1) If the condensate overflow sensor option is utilized connect 'CS' at the condensing section to 'CS' at the air handler. Be sure to ground power supply.
- 2) If service LED is utilized connect 'ALR' terminal on the UPM board to 'L' on the thermostat sub base. The wiring may be spliced in the air handling unit. The 'ALR' output is hot (R) so check thermostat instruction manual to ensure compatibility.
- 3) 'O' – reversing valve is energized in the cooling mode. Fail safe is to heating.

#### AU/ES/GS Series with and without Electric Heat GT/EV Series with Electric Heat

The ES/GS series units incorporate the ECM variable speed fan motors and control interface boards. On these models the thermostat should be connected to the air handlers and then from the air handler to the condensing section.

In this application utilize a 9 conductor cable from the thermostat to the air handler and 7 conductor cable from the air handler to the condensing section.

Connection point logic is as follows:

| From Thermostat  | To Air Handler    | To Condensing Section |
|------------------|-------------------|-----------------------|
| C                | C                 | C                     |
| R                | R                 | R                     |
| G                | G                 |                       |
| O <sup>(3)</sup> | O                 | O                     |
| Y/Y1             | Y/Y1              | Y/Y1                  |
| Y2               | Y2                | Y2                    |
| G                | G                 |                       |
|                  | CS <sup>(1)</sup> | CS <sup>(1)</sup>     |
| L <sup>(2)</sup> | Splice            | ALR <sup>(2)</sup>    |
| E                | E                 |                       |

### NOTES:

- 1) If the condensate overflow sensor option is utilized connect 'CS' at the condensing section to 'CS' at the air handler. Be sure to ground power supply.
- 2) If service LED is utilized connect 'ALR' terminal on the UPM board to 'L' on the thermostat sub base. The wiring may be spliced in the air handling unit. The 'ALR' output is hot (R) so check thermostat instruction manual to ensure compatibility.
- 3) 'O' – reversing valve is energized in the cooling mode. Fail safe is to heating.
- 4) Utilized when electric strip heater package present.

### CONSIDERATIONS

- 1) Always check incoming line voltage power supply and secondary control voltage for adequacy. Transformer primaries are dual tapped for 208 and 230 volts. Connect the appropriate tap to ensure a minimum of 19 volts secondary control voltage. 24 volts is ideal for best operation.

- 2) Long length thermostat and control wiring leads may create voltage drop. Increase wire gauge or up-size transformers may be required to insure minimum secondary voltage supply.
- 3) FHP recommends the following guidelines for wiring between a thermostat and the unit: 18 GA up to 60 foot, 16 GA up to 100 ft and 14 GA up to 140 ft.
- 4) Do not apply additional controlled devices to the control circuit power supply without consulting the factory. Doing so may void equipment warranties.
- 5) Check with all code authorities on requirements involving condensate disposal/over flow protection criteria.

**WATER PIPING:**

**CAUTION:** Water piping exposed to extreme low ambient temperatures are subject to freezing. Remember water freezes at 32°F.

Supply and return piping must be as large as the water connections on the condensing section (larger on long runs). Never use flexible hoses of a smaller inside diameter than that of the water connections on the unit. The condensing sections are supplied with either a copper or optional cupro-nickel condenser. Copper is adequate for ground water that is not high in mineral content. Should your well driller express concern regarding the quality of the well water available or should any known hazards exist in your area, we recommend proper testing to assure the well water quality is suitable for use with water source equipment. In conditions anticipating moderate scale formation or in brackish water a cupro-nickel heat exchanger is recommended.

**CAUTION:** Galvanized pipe or fittings are not recommended for use with these units due to the possible galvanic corrosion.

Both the supply and discharge water lines will sweat if subject to low water temperature. These lines should be insulated to prevent damage from condensation.

All manual flow valves used in the system must be ball valves. Globe and gate valves must not be used due to high pressure drop and poor throttling characteristics.

Never exceed the recommended water flow rates. Serious damage or erosion of the water to refrigerant heat exchanger could occur.

**CAUTION:** Improper heat exchanger water flow due to piping, valving or improper pump operation is hazardous to the unit and constitutes abuse which will void the heat exchanger and compressor warranty.

All condensing sections are equipped with female pipe thread fittings. Consult the specification sheets for sizes. Teflon tape sealer should be used when connecting water piping connections to the units to insure against leaks and possible heat exchanger fouling. Do not overtighten the connections. Flexible hoses should be used between the unit and the rigid

system to avoid possible vibration. Ball valves should be installed in the supply and return lines for unit isolation and unit water flow balancing.

When a water well is used exclusively for supplying water to the heat pump, the pump should operate only when the heat pump operates. A double pole single throw (DP/ST) contactor (Figure #3) can be used to operate the well pump with the heat pump.

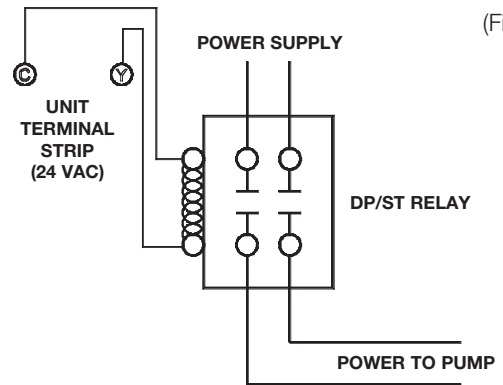

(Figure #3)

When two or more units are supplied from one well, the pump can be wired (Figure #4) to operate independently from either unit. An upsized VA transformer may be required in either case.

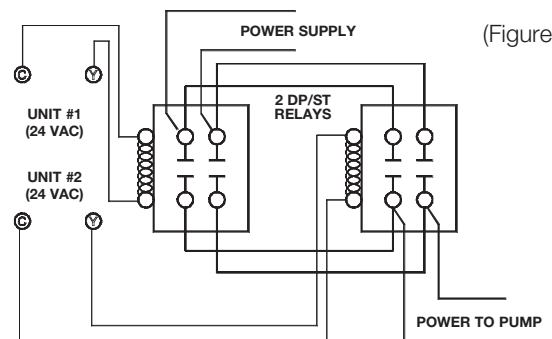

(Figure #4)

Pressure regulating valves can be used to increase or decrease the water flow through the heat pump in response to the refrigerant pressure. In some cases more water may be required in heating than in cooling, or vice versa. If installed an optional refrigerant schrader tap (P/N 093-000) is required in the refrigerant line located between the reversing valve and the water-to-refrigerant heat exchanger on all "EM/EC" condensing sections. The schrader tap is standard on the "GT/GS and EV/ES" condensing section.

Pressure / temperature ports are recommended in both the supply and return lines for system flow balancing. The water flow can be accurately set by measuring the water-to-refrigerant heat exchangers water side pressure drop. See the unit specification sheets for the water flow and pressure drop information.

The discharge water from the heat pump is not contaminated in any manner and can be disposed of in various ways depending on local codes (i.e. discharge well, dry well, storm sewer, drain field, stream, pond, etc.)

### REFRIGERANT LINES:

The installation of the copper refrigerant tubing must be done with care to obtain reliable, trouble-free operation. This installation should only be performed by qualified refrigeration service and installation personnel.

Refrigerant lines generally can and should be routed and supported so as to prevent the transmission of vibrations into the building structure. Experience and good design practice dictate 75 feet as the maximum practical length for interconnecting refrigerant lines in split system heat pumps without special considerations. Beyond 75 feet, system losses become considerable and the total refrigerant charge required can compromise the reliability and design life of the equipment.

Refrigerant lines should be sized in accordance with Table 1 through 5 in the following instructions. Copper tubing should be clean and free of moisture and dirt or debris. The suction and liquid lines **MUST** be insulated with at least 3/8" wall, closed-cell foam rubber insulation or the equivalent.

### GENERAL INFORMATION: (Refrigerant Lines)

1. Pressure drop (friction losses) in refrigerant suction lines reduces system capacity and increases power consumption by as much as 2% or more, depending on the line length, number of bends, etc. Pressure drop in liquid lines affects system performance to a lesser degree, provided that a solid column of liquid (no flash gas) is being delivered to the refrigerant metering device, and that the liquid pressure at the refrigerant metering device is sufficient to produce the required refrigerant flow.
2. Oil is continually being circulated with the refrigerant so, oil return to the compressor is always a consideration in line sizing. Suction lines on split system heat pumps are also hot gas lines in the heating mode, but are treated as suction lines for sizing purposes. If the recommended suction lines sizes are used, there should be no problem with oil return.
3. Vertical lines should be kept to a minimum. Vertical liquid lines will have a vertical liquid lift in either heating or cooling, and the weight of the liquid head is added to the friction loss to arrive at the total line pressure drop.
4. Wherever possible, the air handler should be installed at a higher elevation than the condensing section to aid with oil return to the compressor.

### LINEAR VS. EQUIVALENT LINE LENGTH:

Linear Line Length - is the actual measured length of the line including bends. This issued to calculate the

additional refrigerant charge that must be added to the system (See Refrigerant Charging tables and examples).

Equivalent Line Length - is the combination of the actual lengths of all straight runs and the equivalent length of all bends valves and fittings in a particular line. The equivalent length of a bend, valve or fitting is equal to the length of a straight tube of the same diameter having the same pressure drop as the particular valve or fitting. The ASHRAE Fundamentals Handbook, provides tables for determining the equivalent length of various bends, valves and fittings. Liquid and suction line sizes as shown in Table 1 through 5 are based on Equivalent Line Length.

### CONNECTING REFRIGERANT LINES:

Use only ACR grade copper tubing and keep ends sealed until joints are made.

For best performance, select routing of refrigerant lines for minimum distance and fewest number of bends.

Size lines in accordance with Table 1 through 5.

Cut crimped ends off the air handler suction and liquid lines. Connect and braze lines to the air handler. Note: that the air handler is factory supplied with a holding charge of dry nitrogen.

Connect and braze lines to service valves on the condensing section (See figure #5).

**CAUTION:** Always wrap the body of the service valve with a wet towel or apply some other form of heat sink prior to brazing and direct flame away from the valve body. Failure to do so will result in damage to the valve. Valve body temperature must remain below 250°F to protect the internal rubber "O" rings and seals.

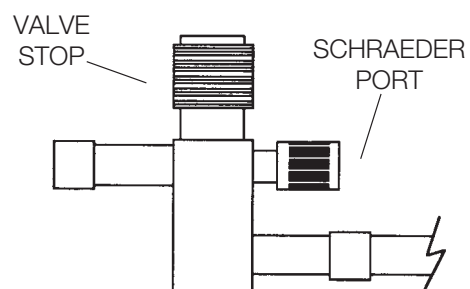

| Unit Size       |         | Valve Conn. Size | Allen Wrench Size |
|-----------------|---------|------------------|-------------------|
| EM007-042       | Suction | 3/4              | 5/16              |
| EM048-070       | Suction | 7/8              | 5/16              |
| EC018 - 042     | Suction | 3/4              | 5/16              |
| EC048 - 070     | Suction | 7/8              | 5/16              |
| GT/GS024-048    | Suction | 3/4              | 5/16              |
| GT/GS062-070    | Suction | 7/8              | 5/16              |
| AU EV/ES024-048 | Suction | 3/4              | 5/16              |
| AU EV/ES060-071 | Suction | 7/8              | 5/16              |
| All Valves      | Liquid  | 3/8              | 3/16              |

SERVICE VALVE: (Figure #5)

Pressurize the refrigerant line set and air handler to 150lbs with dry nitrogen through the schraeder ports provided on the service valves. Check line set and unit connections for leaks.

Once system integrity is verified, evacuate line set and air handler with a good vacuum pump to 500 microns and hold for one half hour.

**NOTE: PUMP-DOWN MUST NEVER BE USED WITH HEAT PUMPS.**

**CHARGING THE SYSTEM:**

Do not overcharge the system. Charge all systems by weight as determined from Tables 1 through 6 and the supplied factory charge. Remember the outdoor unit is factory charged with sufficient refrigerant to support the air handler, condensing section and 25 feet of liquid line. If the lines are less or more than 25 feet, then a charge adjustment must be calculated. Refer to examples #1 and #2 following Table 6.

**CAUTION:** High pressure refrigerant gas and liquid is present in the unit. Liquid refrigerant can cause severe burns to exposed skin areas. Wear safety glasses to protect the eyes. Liquid refrigerant in contact with the eyes could cause loss of sight.

Open both service valves in the condensing section by turning the valve stops located at the top of each valve counter-clockwise with an Allen wrench (See Figure #5 for appropriate Allen wrench sizes). Make sure that both valves are fully open.

**THINGS TO REMEMBER:**

Do not oversize liquid lines unless absolutely unavoidable. If oversized lines must be used, a suction line accumulator may be required and the addition of a crankcase heater may be necessary. Consult the Factory for recommendation.

If the calculated Equivalent Line Length falls between the lengths shown on Table 1 through 5, use tubing sized for the next longer length.

**TABLE 1: Refrigerant Charge, Line Sizing and Capacity multiplier chart "EM Series"**

| System Model        | Factory R22 Charge (Oz) | REFRIGERANT LINE O.D. SIZE (BASED ON EQUIVALENT LINE LENGTH) |      |        |       |        |       |        |       |        |       |        |       |        |       |        |       |         |       |         |       | Suct. Line Vert. Riser Max. O.D. |
|---------------------|-------------------------|--|------|--------|-------|--------|-------|--------|-------|--------|-------|--------|-------|--------|-------|--------|-------|---------|-------|---------|-------|----------------------------------|
|                     |                         | 15 FT.   |      | 25 FT. |       | 35 FT. |       | 45 FT. |       | 50 FT. |       | 60 FT. |       | 70 FT. |       | 80 FT. |       | 120 FT. |       | 150 FT. |       |                                  |
|                     |                         | LIQ.   | SUC. | LIQ.   | SUC.  | LIQ.   | SUC.  | LIQ.   | SUC.  | LIQ.   | SUC.  | LIQ.   | SUC.  | LIQ.   | SUC.  | LIQ.   | SUC.  | LIQ.    | SUC.  | LIQ.    | SUC.  |                                  |
| EM007               | 21                      | 1/4  | 5/8  | 1/4    | 5/8   | 1/4    | 5/8   | 5/16   | 3/4   | —      | —     | —      | —     | —      | —     | —      | —     | —       | —     | —       | —     | 5/8                              |
| EM009               | 23                      | 1/4  | 5/8  | 1/4    | 5/8   | 1/4    | 5/8   | 5/16   | 3/4   | —      | —     | —      | —     | —      | —     | —      | —     | —       | —     | —       | —     | 5/8                              |
| EM012               | 26                      | 1/4  | 5/8  | 1/4    | 5/8   | 1/4    | 5/8   | 5/16   | 3/4   | —      | —     | —      | —     | —      | —     | —      | —     | —       | —     | —       | —     | 5/8                              |
| EM015               | 32                      | 1/4  | 5/8  | 1/4    | 5/8   | 1/4    | 5/8   | 5/16   | 3/4   | —      | —     | —      | —     | —      | —     | —      | —     | —       | —     | —       | —     | 5/8                              |
| EM018               | 41                      | 1/4  | 5/8  | 1/4    | 3/4   | 5/16   | 3/4   | 5/16   | 3/4   | 5/16   | 3/4   | 5/16   | 3/4   | 5/16   | 7/8   | 3/8    | 7/8   | 3/8     | 7/8   | 3/8     | 7/8   | 5/8                              |
| EM024               | 54                      | 5/16   | 5/8  | 5/16   | 3/4   | 5/16   | 3/4   | 5/16   | 3/4   | 3/8    | 3/4   | 3/8    | 7/8   | 3/8    | 7/8   | 3/8    | 7/8   | 3/8     | 7/8   | 3/8     | 7/8   | 3/4                              |
| EM028               | 47                      | 5/16   | 5/8  | 5/16   | 3/4   | 5/16   | 3/4   | 5/16   | 3/4   | 3/8    | 3/4   | 3/8    | 7/8   | 3/8    | 7/8   | 3/8    | 7/8   | 3/8     | 7/8   | 3/8     | 7/8   | 3/4                              |
| EM031               | 52                      | 5/16   | 3/4  | 3/8    | 3/4   | 3/8    | 3/4   | 3/8    | 3/4   | 3/8    | 7/8   | 3/8    | 7/8   | 3/8    | 7/8   | 3/8    | 7/8   | 1/2     | 7/8   | 1/2     | 7/8   | 3/4                              |
| EM036               | 65                      | 5/16   | 3/4  | 3/8    | 3/4   | 3/8    | 3/4   | 3/8    | 3/4   | 3/8    | 7/8   | 3/8    | 7/8   | 3/8    | 7/8   | 3/8    | 7/8   | 1/2     | 7/8   | 1/2     | 7/8   | 3/4                              |
| EM041               | 58                      | 5/16   | 3/4  | 3/8    | 3/4   | 3/8    | 3/4   | 3/8    | 7/8   | 3/8    | 7/8   | 3/8    | 7/8   | 3/8    | 7/8   | 1/2    | 7/8   | 1/2     | 7/8   | 1/2     | 7/8   | 7/8                              |
| EM042               | 61                      | 5/16   | 3/4  | 3/8    | 3/4   | 3/8    | 3/4   | 3/8    | 7/8   | 3/8    | 7/8   | 3/8    | 7/8   | 3/8    | 7/8   | 1/2    | 7/8   | 1/2     | 7/8   | 1/2     | 7/8   | 7/8                              |
| EM048               | 69                      | 3/8  | 7/8  | 3/8    | 7/8   | 3/8    | 7/8   | 3/8    | 7/8   | 3/8    | 7/8   | 1/2    | 7/8   | 1/2    | 1-1/8 | 1/2    | 1-1/8 | 1/2     | 1-1/8 | 1/2     | 1-1/8 | 7/8                              |
| EM060               | 83                      | 3/8  | 7/8  | 3/8    | 1-1/8 | 1/2    | 1-1/8 | 1/2    | 1-1/8 | 1/2    | 1-1/8 | 1/2    | 1-1/8 | 1/2    | 1-1/8 | 1/2    | 1-1/8 | 1/2     | 1-1/8 | 1/2     | 1-1/8 | 1-1/8                            |
| EM070               | 115                     | 3/8  | 7/8  | 3/8    | 1-1/8 | 1/2    | 1-1/8 | 1/2    | 1-1/8 | 1/2    | 1-1/8 | 1/2    | 1-1/8 | 1/2    | 1-1/8 | 1/2    | 1-1/8 | 1/2     | 1-1/8 | 1/2     | 1-1/8 | 1-1/8                            |
| CAPACITY MULTIPLIER |                         | 1.00   |      | .995   |       | .990   |       | .990   |       | .985   |       | .980   |       | .975   |       | .970   |       | .960    |       |         |       |                                  |

**TABLE 2: Refrigerant Charge, Line Sizing and Capacity multiplier chart "EC Series"**

| System Model        | Factory R410A Charge (Oz) | REFRIGERANT LINE O.D. SIZE (BASED ON EQUIVALENT LINE LENGTH) |      |        |       |        |       |        |       |        |       |        |       |        |       |        |       |         |       |         |       | Suct. Line Riser Max. |
|---------------------|---------------------------|--|------|--------|-------|--------|-------|--------|-------|--------|-------|--------|-------|--------|-------|--------|-------|---------|-------|---------|-------|-----------------------|
|                     |                           | 15 FT.   |      | 25 FT. |       | 35 FT. |       | 45 FT. |       | 50 FT. |       | 60 FT. |       | 70 FT. |       | 80 FT. |       | 120 FT. |       | 150 FT. |       |                       |
|                     |                           | LIQ.   | SUC. | LIQ.   | SUC.  | LIQ.   | SUC.  | LIQ.   | SUC.  | LIQ.   | SUC.  | LIQ.   | SUC.  | LIQ.   | SUC.  | LIQ.   | SUC.  | LIQ.    | SUC.  | LIQ.    | SUC.  |                       |
| EC018               | 46                        | 5/16   | 5/8  | 5/16   | 3/4   | 5/16   | 3/4   | 5/16   | 3/4   | 3/8    | 3/4   | 3/8    | 7/8   | 3/8    | 7/8   | 3/8    | 7/8   | 3/8     | 7/8   | 3/8     | 7/8   | 3/4                   |
| EC024               | 56                        | 5/16   | 5/8  | 5/16   | 3/4   | 5/16   | 3/4   | 5/16   | 3/4   | 3/8    | 3/4   | 3/8    | 7/8   | 3/8    | 7/8   | 3/8    | 7/8   | 3/8     | 7/8   | 3/8     | 7/8   | 3/4                   |
| EC030               | 48                        | 5/16   | 5/8  | 5/16   | 3/4   | 5/16   | 3/4   | 5/16   | 3/4   | 3/8    | 3/4   | 3/8    | 7/8   | 3/8    | 7/8   | 3/8    | 7/8   | 3/8     | 7/8   | 3/8     | 7/8   | 3/4                   |
| EC036               | 69                        | 5/16   | 3/4  | 3/8    | 3/4   | 3/8    | 3/4   | 3/8    | 3/4   | 3/8    | 7/8   | 3/8    | 7/8   | 3/8    | 7/8   | 3/8    | 7/8   | 1/2     | 7/8   | 1/2     | 7/8   | 3/4                   |
| EC042               | 70                        | 5/16   | 3/4  | 3/8    | 3/4   | 3/8    | 3/4   | 3/8    | 3/4   | 3/8    | 7/8   | 3/8    | 7/8   | 3/8    | 7/8   | 1/2    | 7/8   | 1/2     | 7/8   | 1/2     | 7/8   | 7/8                   |
| EC048               | 79                        | 3/8  | 3/4  | 3/8    | 7/8   | 3/8    | 7/8   | 3/8    | 7/8   | 3/8    | 7/8   | 1/2    | 7/8   | 1/2    | 1-1/8 | 1/2    | 1-1/8 | 1/2     | 1-1/8 | 1/2     | 1-1/8 | 7/8                   |
| EC060               | 93                        | 3/8  | 7/8  | 3/8    | 1-1/8 | 1/2    | 1-1/8 | 1/2    | 1-1/8 | 1/2    | 1-1/8 | 1/2    | 1-1/8 | 1/2    | 1-1/8 | 1/2    | 1-1/8 | 1/2     | 1-1/8 | 1/2     | 1-1/8 | 1-1/8                 |
| EC070               | 120                       | 3/8  | 7/8  | 3/8    | 1-1/8 | 1/2    | 1-1/8 | 1/2    | 1-1/8 | 1/2    | 1-1/8 | 1/2    | 1-1/8 | 1/2    | 1-1/8 | 1/2    | 1-1/8 | 1/2     | 1-1/8 | 1/2     | 1-1/8 | 1-1/8                 |
| CAPACITY MULTIPLIER |                           | 1.00   |      | .995   |       | .990   |       | .990   |       | .985   |       | .980   |       | .975   |       | .970   |       | .960    |       |         |       |                       |

**TABLE 3:** Refrigerant Charge, Line Sizing and Capacity multiplier chart “GT/GS Series”

| System Model        | Factory R22 Charge (Oz) | REFRIGERANT LINE O.D. SIZE (BASED ON EQUIVALENT LINE LENGTH) |      |        |       |        |       |        |       |        |       |        |       |        |       |        |       |         |       |         |       | Suct. Line Vert. Riser Max. O.D. |
|---------------------|-------------------------|--|------|--------|-------|--------|-------|--------|-------|--------|-------|--------|-------|--------|-------|--------|-------|---------|-------|---------|-------|----------------------------------|
|                     |                         | 15 FT.   |      | 25 FT. |       | 35 FT. |       | 45 FT. |       | 50 FT. |       | 60 FT. |       | 70 FT. |       | 80 FT. |       | 120 FT. |       | 150 FT. |       |                                  |
|                     |                         | LIQ.   | SUC. | LIQ.   | SUC.  | LIQ.   | SUC.  | LIQ.   | SUC.  | LIQ.   | SUC.  | LIQ.   | SUC.  | LIQ.   | SUC.  | LIQ.   | SUC.  | LIQ.    | SUC.  | LIQ.    | SUC.  |                                  |
| GT/GS024            | 36                      | 5/16   | 5/8  | 5/16   | 3/4   | 5/16   | 3/4   | 5/16   | 3/4   | 3/8    | 3/4   | 3/8    | 7/8   | 3/8    | 7/8   | 3/8    | 7/8   | 3/8     | 7/8   | 3/8     | 7/8   | 3/4                              |
| GT/GS030            | 79                      | 5/16   | 5/8  | 5/16   | 3/4   | 5/16   | 3/4   | 5/16   | 3/4   | 3/8    | 3/4   | 3/8    | 7/8   | 3/8    | 7/8   | 3/8    | 7/8   | 3/8     | 7/8   | 3/8     | 7/8   | 3/4                              |
| GT/GS036            | 83                      | 5/16   | 3/4  | 3/8    | 3/4   | 3/8    | 3/4   | 3/8    | 3/4   | 3/8    | 7/8   | 3/8    | 7/8   | 3/8    | 7/8   | 3/8    | 7/8   | 1/2     | 7/8   | 1/2     | 7/8   | 3/4                              |
| GT/GS042            | 89                      | 5/16   | 3/4  | 3/8    | 3/4   | 3/8    | 3/4   | 3/8    | 7/8   | 3/8    | 7/8   | 3/8    | 7/8   | 3/8    | 7/8   | 1/2    | 7/8   | 1/2     | 7/8   | 1/2     | 7/8   | 7/8                              |
| GT/GS048            | 73                      | 3/8  | 3/4  | 3/8    | 7/8   | 3/8    | 7/8   | 3/8    | 7/8   | 3/8    | 7/8   | 1/2    | 7/8   | 1/2    | 1-1/8 | 1/2    | 1-1/8 | 1/2     | 1-1/8 | 1/2     | 1-1/8 | 7/8                              |
| GT/GS054            | 83                      | 3/8  | 7/8  | 3/8    | 7/8   | 3/8    | 7/8   | 1/2    | 1-1/8 | 1/2    | 1-1/8 | 1/2    | 1-1/8 | 1/2    | 1-1/8 | 1/2    | 1-1/8 | 1/2     | 1-1/8 | 1/2     | 1-1/8 | 7/8                              |
| GT/GS062            | 105                     | 3/8  | 7/8  | 3/8    | 1-1/8 | 1/2    | 1-1/8 | 1/2    | 1-1/8 | 1/2    | 1-1/8 | 1/2    | 1-1/8 | 1/2    | 1-1/8 | 1/2    | 1-1/8 | 1/2     | 1-1/8 | 1/2     | 1-1/8 | 1-1/8                            |
| GT/GS070            | 115                     | 3/8  | 7/8  | 3/8    | 1-1/8 | 1/2    | 1-1/8 | 1/2    | 1-1/8 | 1/2    | 1-1/8 | 1/2    | 1-1/8 | 1/2    | 1-1/8 | 1/2    | 1-1/8 | 1/2     | 1-1/8 | 1/2     | 1-1/8 | 1-1/8                            |
| CAPACITY MULTIPLIER |                         | 1.00   |      | .995   |       | 0.990  |       | 0.990  |       | 0.985  |       | 0.980  |       | 0.975  |       | 0.970  |       | 0.960   |       |         |       |                                  |

**TABLE 4:** Refrigerant Charge, Line Sizing and Capacity multiplier chart “EV/ES Series”

| System Model        | Factory R410A Charge (Oz) | REFRIGERANT LINE O.D. SIZE (BASED ON EQUIVALENT LINE LENGTH) |      |        |       |        |       |        |       |        |       |        |       |        |       |        |       |         |       |         |       | Suct. Line Vert. Riser Max. O.D. |
|---------------------|---------------------------|--|------|--------|-------|--------|-------|--------|-------|--------|-------|--------|-------|--------|-------|--------|-------|---------|-------|---------|-------|----------------------------------|
|                     |                           | 15 FT.   |      | 25 FT. |       | 35 FT. |       | 45 FT. |       | 50 FT. |       | 60 FT. |       | 70 FT. |       | 80 FT. |       | 120 FT. |       | 150 FT. |       |                                  |
|                     |                           | LIQ.   | SUC. | LIQ.   | SUC.  | LIQ.   | SUC.  | LIQ.   | SUC.  | LIQ.   | SUC.  | LIQ.   | SUC.  | LIQ.   | SUC.  | LIQ.   | SUC.  | LIQ.    | SUC.  | LIQ.    | SUC.  |                                  |
| EV018               | 58                        | 5/16   | 5/8  | 5/16   | 3/4   | 5/16   | 3/4   | 5/16   | 3/4   | 3/8    | 3/4   | 3/8    | 7/8   | 3/8    | 7/8   | 3/8    | 7/8   | 3/8     | 7/8   | 3/8     | 7/8   | 3/4                              |
| EV/ES024            | 43                        | 5/16   | 5/8  | 5/16   | 3/4   | 5/16   | 3/4   | 5/16   | 3/4   | 3/8    | 3/4   | 3/8    | 7/8   | 3/8    | 7/8   | 3/8    | 7/8   | 3/8     | 7/8   | 3/8     | 7/8   | 3/4                              |
| EV/ES030            | 68                        | 5/16   | 5/8  | 5/16   | 3/4   | 5/16   | 3/4   | 5/16   | 3/4   | 3/8    | 3/4   | 3/8    | 7/8   | 3/8    | 7/8   | 3/8    | 7/8   | 3/8     | 7/8   | 3/8     | 7/8   | 3/4                              |
| EV/ES036            | 83                        | 5/16   | 3/4  | 3/8    | 3/4   | 3/8    | 3/4   | 3/8    | 3/4   | 3/8    | 7/8   | 3/8    | 7/8   | 3/8    | 7/8   | 3/8    | 7/8   | 1/2     | 7/8   | 1/2     | 7/8   | 3/4                              |
| EV/ES042            | 89                        | 5/16   | 3/4  | 3/8    | 3/4   | 3/8    | 3/4   | 3/8    | 3/4   | 3/8    | 7/8   | 3/8    | 7/8   | 3/8    | 7/8   | 1/2    | 7/8   | 1/2     | 7/8   | 1/2     | 7/8   | 7/8                              |
| EV/ES048            | 77                        | 3/8  | 3/4  | 3/8    | 7/8   | 3/8    | 7/8   | 3/8    | 7/8   | 3/8    | 7/8   | 1/2    | 7/8   | 1/2    | 1-1/8 | 1/2    | 1-1/8 | 1/2     | 1-1/8 | 1/2     | 1-1/8 | 7/8                              |
| EV/ES060            | 105                       | 3/8  | 7/8  | 3/8    | 1-1/8 | 1/2    | 1-1/8 | 1/2    | 1-1/8 | 1/2    | 1-1/8 | 1/2    | 1-1/8 | 1/2    | 1-1/8 | 1/2    | 1-1/8 | 1/2     | 1-1/8 | 1/2     | 1-1/8 | 1-1/8                            |
| EV/ES070            | 120                       | 3/8  | 7/8  | 3/8    | 1-1/8 | 1/2    | 1-1/8 | 1/2    | 1-1/8 | 1/2    | 1-1/8 | 1/2    | 1-1/8 | 1/2    | 1-1/8 | 1/2    | 1-1/8 | 1/2     | 1-1/8 | 1/2     | 1-1/8 | 1-1/8                            |
| CAPACITY MULTIPLIER |                           | 1.00   |      | .995   |       | 0.990  |       | 0.990  |       | 0.985  |       | 0.980  |       | 0.975  |       | 0.970  |       | 0.960   |       |         |       |                                  |

**TABLE 5:** Refrigerant Charge, Line Sizing and Capacity multiplier chart “ES & AU Two Stage Series”

| System Model        | Factory R410A Charge (Oz) | REFRIGERANT LINE O.D. SIZE (BASED ON EQUIVALENT LINE LENGTH) |      |        |       |        |       |        |       |        |       |        |       |        |       |        |       |         |       |         |       | Suct. Line Riser Max. |
|---------------------|---------------------------|--|------|--------|-------|--------|-------|--------|-------|--------|-------|--------|-------|--------|-------|--------|-------|---------|-------|---------|-------|-----------------------|
|                     |                           | 15 FT.   |      | 25 FT. |       | 35 FT. |       | 45 FT. |       | 50 FT. |       | 60 FT. |       | 70 FT. |       | 80 FT. |       | 120 FT. |       | 150 FT. |       |                       |
|                     |                           | LIQ.   | SUC. | LIQ.   | SUC.  | LIQ.   | SUC.  | LIQ.   | SUC.  | LIQ.   | SUC.  | LIQ.   | SUC.  | LIQ.   | SUC.  | LIQ.   | SUC.  | LIQ.    | SUC.  | LIQ.    | SUC.  |                       |
| AU/ES025            | 79                        | 5/16   | 5/8  | 5/16   | 3/4   | 5/16   | 3/4   | 5/16   | 3/4   | 3/8    | 3/4   | 3/8    | 7/8   | 3/8    | 7/8   | 3/8    | 7/8   | 3/8     | 7/8   | 3/8     | 7/8   | 5/8                   |
| AU/ES035            | 79                        | 5/16   | 3/4  | 3/8    | 3/4   | 3/8    | 3/4   | 3/8    | 3/4   | 3/8    | 7/8   | 3/8    | 7/8   | 3/8    | 7/8   | 3/8    | 7/8   | 1/2     | 7/8   | 1/2     | 7/8   | 3/4                   |
| AU/ES049            | 79                        | 3/8  | 3/4  | 3/8    | 7/8   | 3/8    | 7/8   | 3/8    | 7/8   | 3/8    | 7/8   | 1/2    | 7/8   | 1/2    | 7/8   | 1/2    | 7/8   | 1/2     | 7/8   | 1/2     | 7/8   | 7/8                   |
| AU/ES061            | 99                        | 3/8  | 7/8  | 3/8    | 1-1/8 | 1/2    | 1-1/8 | 1/2    | 1-1/8 | 1/2    | 1-1/8 | 1/2    | 1-1/8 | 1/2    | 1-1/8 | 1/2    | 1-1/8 | 1/2     | 1-1/8 | 1/2     | 1-1/8 | 7/8                   |
| AU/ES071            | 135                       | 3/8  | 7/8  | 3/8    | 1-1/8 | 1/2    | 1-1/8 | 1/2    | 1-1/8 | 1/2    | 1-1/8 | 1/2    | 1-1/8 | 1/2    | 1-1/8 | 1/2    | 1-1/8 | 1/2     | 1-1/8 | 1/2     | 1-1/8 | 7/8                   |
| CAPACITY MULTIPLIER |                           | 1.00   |      | .995   |       | 0.990  |       | 0.990  |       | 0.985  |       | 0.980  |       | 0.975  |       | 0.970  |       | 0.960   |       |         |       |                       |

**TABLE 6**  
Liquid Line Charge Per Linear Foot

|                         | Liquid Line Size, O.D. |      |     |      |      |
|-------------------------|------------------------|------|-----|------|------|
|                         | 1/4                    | 5/16 | 3/8 | 1/2  | 5/8  |
| R22 & R410A oz per foot | .25                    | .44  | .60 | 1.15 | 1.95 |

**EXAMPLE 1:**

Model EMCS/EMAH042 with 45 feet of 3/8” O.D. Liquid Line.  
 Total System Charge = Factory Charge + (45 ft - 25 ft) x .60 oz/ft  
 Total System Charge = 61 oz + (20 ft x .60 oz/ft) = 73 oz  
 Therefore add 12 oz of R22 to the installed system.

**EXAMPLE 2:**

Model EMCS/EMAH042 with 12 feet of 5/16” O.D. Liquid Line.  
 Total System Charge = Factory Charge + (25 ft - 12 ft) x .44 oz/ft  
 Total System Charge = 61 oz + (13 ft x .44 oz/ft) = 55.3 oz  
 Therefore reclaim 5.7 oz of R22 to the installed system.



Maximum Linear (actual) liquid line length without a suction line accumulator is 60 feet. Liquid line length in excess of 100 feet are not recommended either with or without a suction line accumulator.

A liquid line drier-filter is required, it must be of the bi-directional type only and approved for the refrigerant type utilized.

Suction line size must be one of those given in Tables 1 through 5.

Horizontal suction line runs should be pitched slightly toward the compressor to provide free drainage and aid oil return. Do Not exceed the largest diameter given in the tables on horizontal runs.

When brazing always bleed dry nitrogen through refrigerant tubing to displace air and prevent oxidation.

**CAUTION:** Always check refrigerant type on the unit data plate before servicing. Do not use R22 manifold gauges on R-410A units. Doing so could result in severe injury.

#### IN-WARRANTY MATERIAL RETURN:

When contacting your Representative for service or replacement parts, refer to the model and serial number of the unit as stamped on the data plate attached to the unit.

Material may be returned to the factory only with permission of an authorized factory representative. A "Warranty Return Material" tag must be attached to the returned material. Assure that all of the information as called for on the tag is filled out completely and accurately to expedite handling and insure prompt issuance of credits.

Freight charges for all items returned to the factory shall be prepaid. The return of the part does not constitute an order for a replacement. Therefore, a purchase order must be entered through your nearest representative. The order shall include the part number, model number, and serial number of the unit involved. If the part is within the warranty period, and after our inspection of the returned part proves that the failure is due to faulty material or workmanship a credit or replacement part will be issued

**NOTE:** Parts returned without a completed "Warranty Return Material" tag will not be credited.

#### SYSTEM CHECKOUT:

After completing the installation, and before applying power, the following system checks should be made:

- \* Verify that the supply voltage to the equipment is in accordance with the nameplate ratings.
- \* Make sure that all electrical connections are tight and secure.
- \* Check the electrical fusing and wiring for the correct sizes.
- \* Verify that the low voltage wiring between the thermostat and the unit is correct.
- \* Verify that the water piping is complete and correct.
- \* Check that the water flow is correct, and adjust if necessary.
- \* Check the blower for free rotation, and that it is secured to the shaft.
- \* Verify that vibration isolation has been provided.
- \* Be certain that all access panels are secured in place.

#### UNIT START-UP:

1. Set the thermostat to the highest setting.
2. Set the thermostat system switch to "COOL", and the fan switch to the "AUTO" position. The reversing valve solenoid should energize. The compressor and fan should not run.
3. Reduce the thermostat setting approximately 5 degrees below the room temperature.
4. Verify the blower motor and compressor are operating in the cooling mode.
5. Turn the thermostat system switch to the "OFF" position. The blower and compressor should stop running and the reversing valve should deenergize.
6. Leave the unit off for approximately (5) minutes to allow for system equalization.
7. Turn the thermostat to the lowest setting.
8. Set the thermostat switch to "HEAT".
9. Increase the thermostat setting approximately 5 degrees above the room temperature.
10. Verify the blower motor and compressor are operating in the heating mode.
11. Set the thermostat to maintain the desired space temperature.
12. Check for vibrations, leaks, etc...
13. Instruct the owner on the unit and thermostat operation.

- NOTES:
1. SEE UNIT NAME PLATE FOR ELECTRICAL RATING
  2. ALL FIELD WIRING MUST BE IN ACCORDANCE WITH N.E.C.—N.F.P.A. #70
  3. WIRE OUTDOOR T-STAT IN PLACE OF WIRE NUT IF HTR STAGING IS REQUIRED (7.5–20kW)

HEATER PACKAGES CONTAIN THE FOLLOWING:

- 3.5–5kW — HEATER CIRCUIT 1, HR1, EHR
- 7.5–10kW — HEATER CIRCUIT 1, 2, HR1, HR2, EHR, WIRE NUT
- 15kW — HEATER CIRCUIT 1, 2, 3, HR1, HR2, EHR, WIRE NUT
- 20kW — HEATER CIRCUIT 1, 2, 3, 4, HR1, HR2, EHR, WIRE NUT
- 3.5–10kW HEATERS ARE NON FUSED, 15 & 20kW ARE FUSED

LEGEND:

- BR — BLOWER RELAY
- EHR — EMERGENCY HEAT RELAY
- HLS — HIGH TEMP LIMIT SWITCH
- HT1–4 — HEATER ELEMENT 1–4
- HR1,2 — HEATER RELAY 1, 2

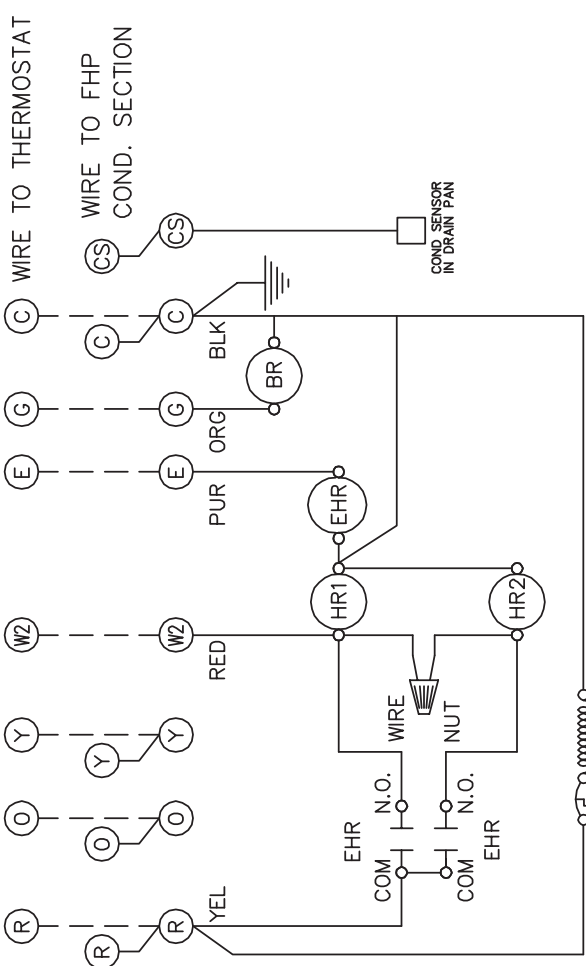
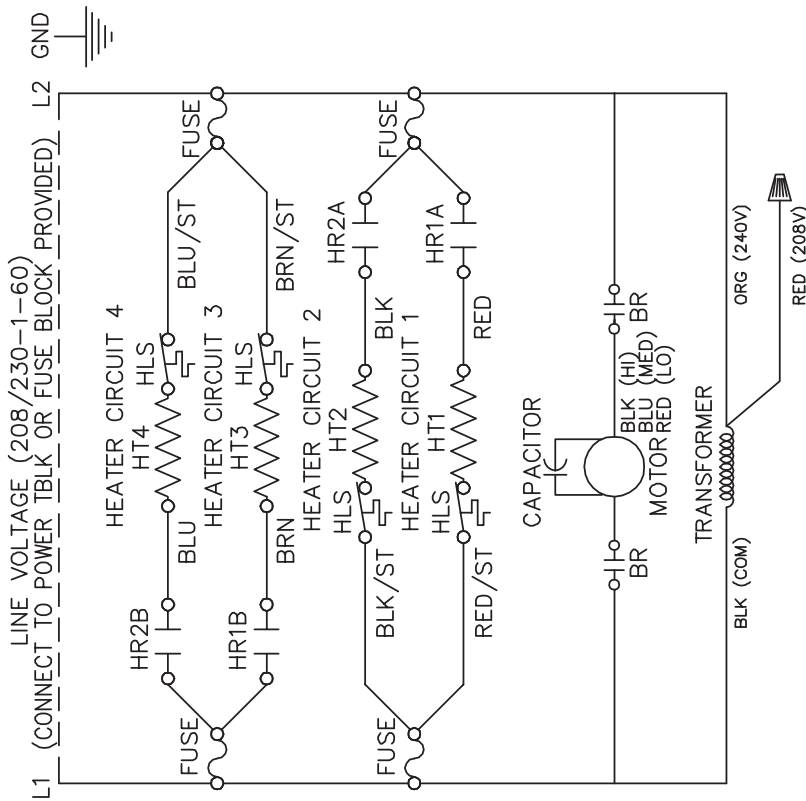

BLOWER RELAY (BR)

NOTES:

1. SEE UNIT NAME PLATE FOR ELECTRICAL RATING
2. ALL FIELD WIRING MUST BE IN ACCORDANCE WITH N.E.C.—N.F.P.A. #70
3. 115V THROUGH 460V BLOWER MOTORS HAVE 3 SPEED TAPS, 575V MOTORS ARE SINGLE SPEED. FOR 460V BLOWER MOTORS, WIRE BLK AND ORG LEADS TOGETHER FOR MED OR LO SPEED OPERATION. CAP ALL UNUSED LEADS.

TRANSFORMER PRIMARY LEAD CLR:

|     |              |
|-----|--------------|
| 120 | — WHT        |
| 208 | — RED        |
| 240 | — ORG        |
| 277 | — BRN        |
| 380 | — PUR OR YEL |
| 460 | — BLK/RED    |
| 575 | — GRN        |

TYPICAL WIRING DIAGRAM

SINGLE PHASE, AIR HANDLER

- NOTES:  
 1. UNIT NAME PLATE FOR ELECTRICAL RATING  
 2. ALL FIELD WIRING MUST BE IN ACCORDANCE WITH N.E.C.—N.F.P.A. #70

STANDARD COMPONENTS LEGEND:  
 BM — BLOWER MOTOR

OPTIONAL COMPONENTS LEGEND:  
 [ ] CBR — 24V CIRCUIT BREAKER  
 [ ] CS — CONDENSATE SENSOR (IN UNIT DRAIN PAN)

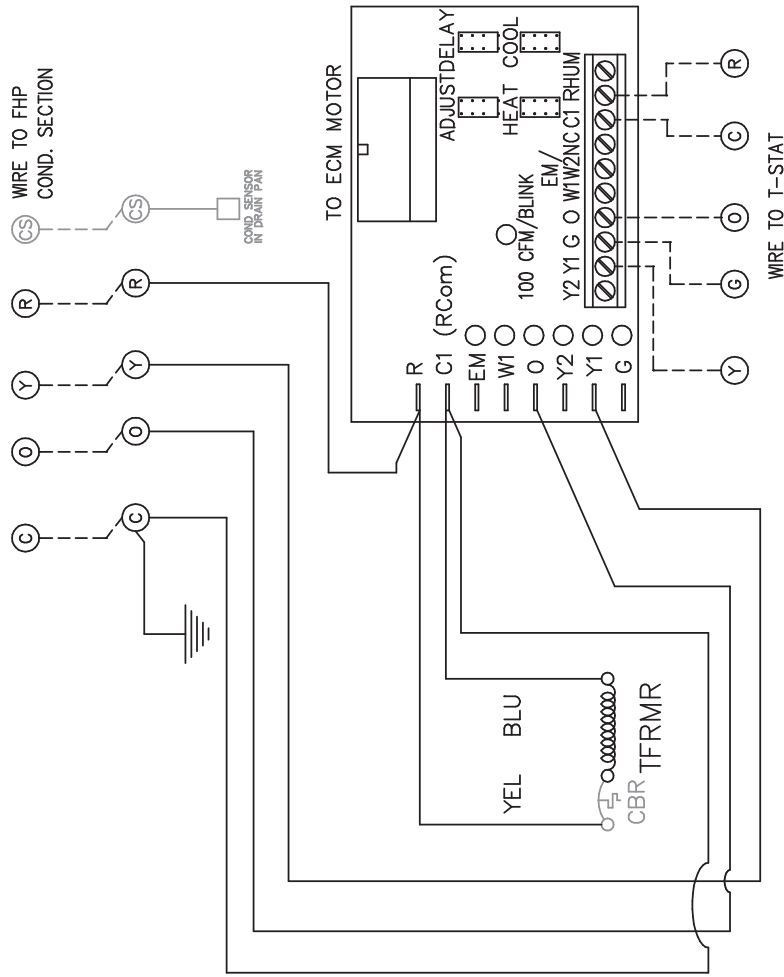
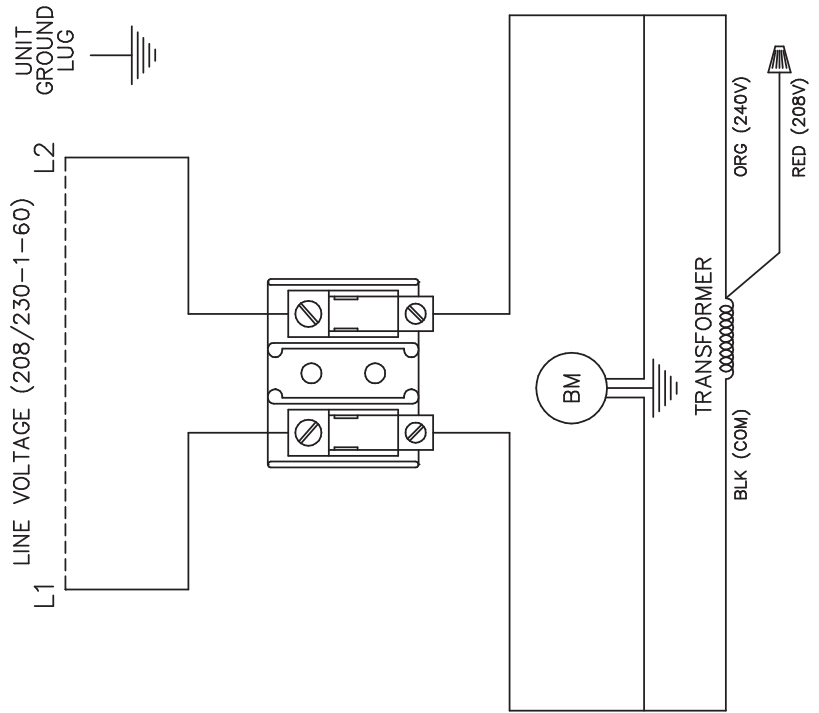

TYPICAL WIRING DIAGRAM

SINGLE PHASE, AIR HANDLER WITH  
 ECM MOTOR

WIRE TO FHP COND. SECTION  
 CS  
 R  
 Y  
 O  
 C

NOTES:  
 1. SEE UNIT NAME PLATE FOR ELECTRICAL RATING  
 2. ALL FIELD WIRING MUST BE IN ACCORDANCE WITH N.E.C.—N.F.P.A. #70

HEATER PACKAGES CONTAIN THE FOLLOWING:  
 3.5-5kW — HEATER CIRCUIT 1, HR1, EHR  
 7.5-10kW — HEATER CIRCUIT 1, 2, HR1, HR2, EHR, WIRE NUT  
 15kW — HEATER CIRCUIT 1, 2, 3, HR1, HR2, EHR, WIRE NUT  
 20kW — HEATER CIRCUIT 1, 2, 3, 4, HR1, HR2, EHR, WIRE NUT  
 3.5-10kW HEATERS ARE NON FUSED, 15 & 20kW ARE FUSED

STANDARD COMPONENTS LEGEND:  
 BM — BLOWER MOTOR  
 EHR — EMERGENCY HEAT RELAY  
 HLS — HEATER LIMIT SWITCH  
 HR — HEATER RELAY  
 HT — HEATER ELEMENT

OPTIONAL COMPONENTS LEGEND:  
 CBR — 24V CIRCUIT BREAKER  
 CS — CONDENSATE SENSOR (IN UNIT DRAIN PAN)

LINE VOLTAGE (208/230-1-60)  
 (CONNECT TO POWER TBLK OR FUSE BLOCK PROVIDED)

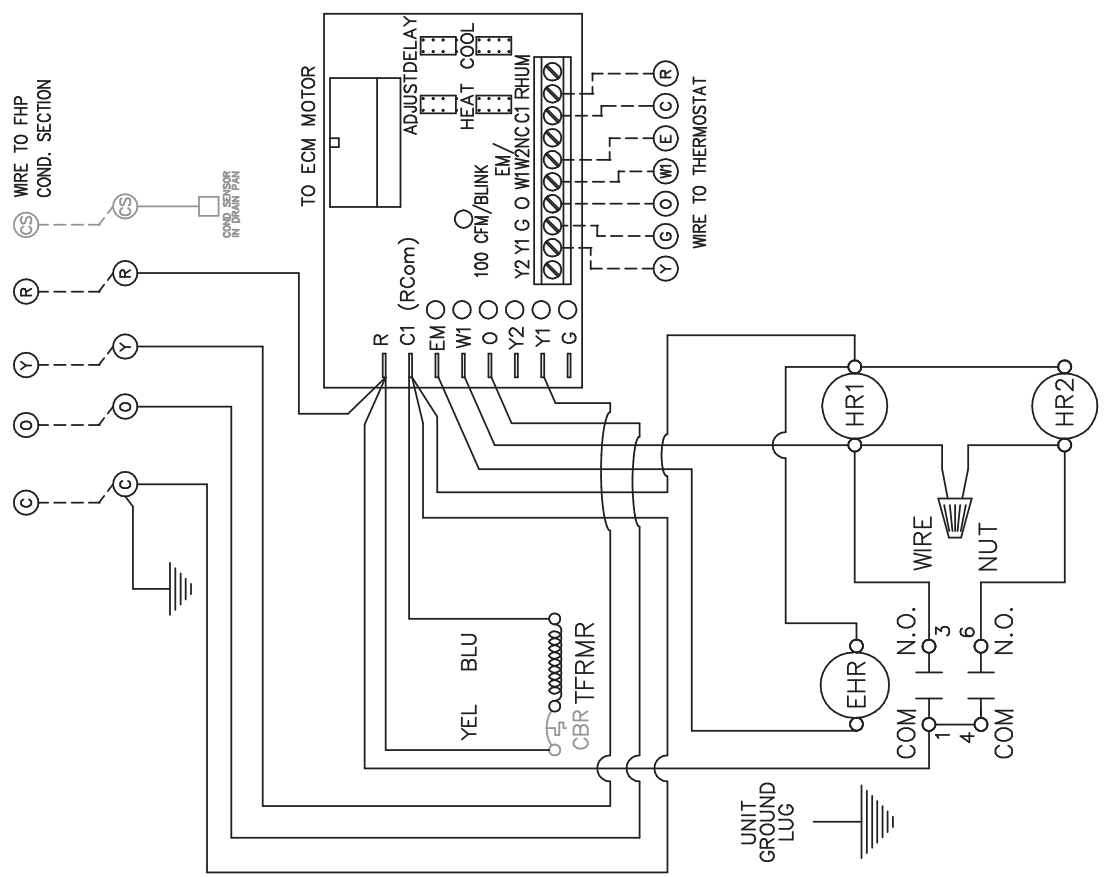
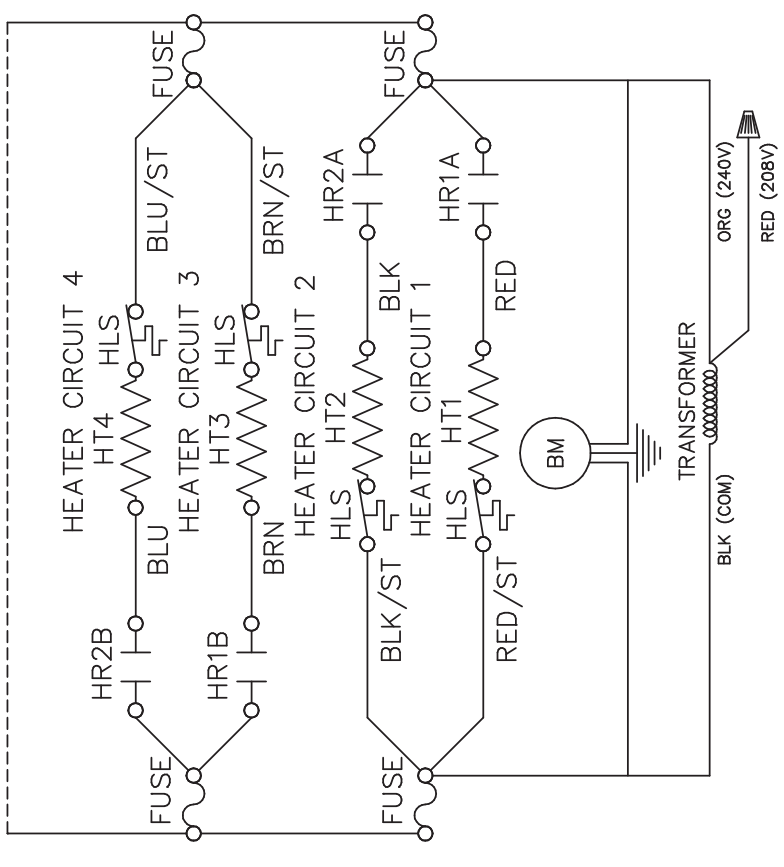

**TYPICAL WIRING DIAGRAM**  
 SINGLE PHASE, AIR HANDLER WITH  
 ELECTRIC HEAT AND ECM MOTOR

| TRANSFORMER PRIMARY LEAD CLR. | UNIT GROUND LUG |
|-------------------------------|-----------------|
| 120 - WHI                     |                 |
| 208 - RED                     |                 |
| 240 - ORG                     |                 |
| 277 - BRN                     |                 |
| 360 - PUR OR YEL              |                 |
| 480 - BLK/RED                 |                 |
| 575 - GRY                     |                 |

FACTORY WIRE —————  
 FIELD WIRE - - - - -

**STANDARD COMPONENTS LEGEND:**  
 CAP - COMPRESSOR CAPACITOR  
 CC - COMPRESSOR CONTACTOR  
 CCH - CRANKCASE HTR (WHEN SUPPLIED)  
 EOVD - EXTERNAL OVERLOAD (NOTE 5)  
 HPS - HIGH PRESSURE SWITCH  
 LPS - LOW PRESSURE SWITCH  
 PTCR - POS TEMP COEFF RSTR (NOTE 4)  
 RV - REVERSING VLV (HEAT PUMPS)

**OPTIONAL COMPONENTS LEGEND:**  
 [ ] AUX - AUXILIARY RELAY (FOR LOOP PUMP, ETC.)  
 [ ] CMFR - COMPRESSOR MALFUNCTION RELAY  
 [ ] CMR - COMPRESSOR MONITOR RELAY  
 [ ] CS - CONDENSATE SENSOR (IN DRAIN PAN OF AIR HANDLER)  
 [ ] FS - FREEZE SENSOR  
 [ ] HRP - HEAT RECOVERY PACKAGE, INCLUDES:  
 HRP M - HEAT RECOVERY PUMP MOTOR  
 HWL - HOT WATER LIMIT (120 OR 140 DEG)  
 SWT - ON/OFF SWITCH AND OVERLOAD PROTECTION

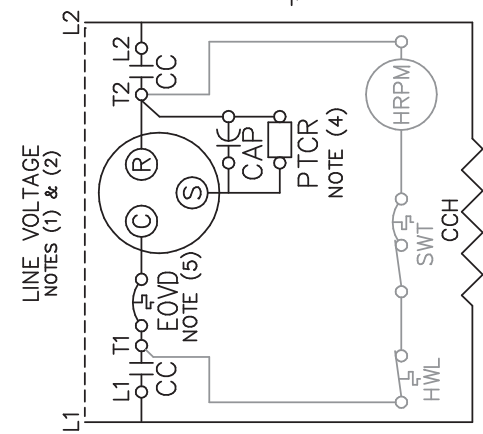

CONNECT TO FHP AIR HANDLING UNIT

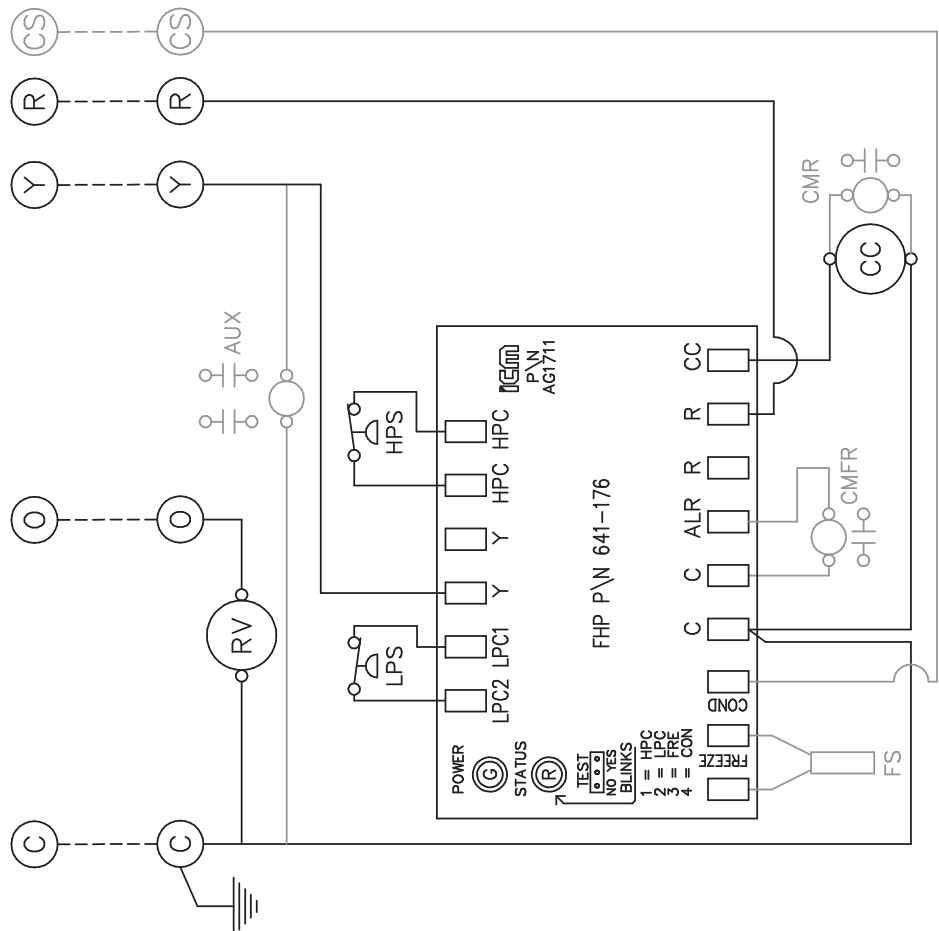

- NOTES:**
- SEE UNIT NAME PLATE FOR ELECTRICAL RATING
  - ALL FIELD WIRING MUST BE IN ACCORDANCE WITH N.E.C.-N.F.P.A. #70, COPPER CONDUCTORS ONLY
  - 208/230V UNITS ARE FACTORY WIRED FOR 230V OPERATION. FOR 208V OPERATION, REMOVE ORG LEAD AND REPLACE WITH RED LEAD. CAP ALL UNUSED LEADS
  - PTCR IS STANDARD ON SELECT UNITS.
  - EXTERNAL OVERLOAD STANDARD ON ALL UNITS EQUIPPED WITH ROTARY COMPRESSORS. UPM-1 INCLUDES BUILT IN: 30-60 SECOND RANDOM START  
 5 MINUTE DELAY ON BREAK  
 90 SECOND LOW PRESSURE BYPASS
  - SETTING THE TEST MODE JUMPER TO YES REDUCES ALL TIME DELAYS TO 5 SECONDS.
  - "FREEZE" PINS ON UPM MUST BE JUMPED TOGETHER IF FREEZE SENSOR IS NOT INSTALLED.
  - BLINK CODES FOR HARD LOCK OUT: 1 - HIGH PRESSURE FAULT  
 2 - LOW PRESSURE FAULT  
 3 - FREEZE FAULT  
 4 - CONDENSATE FAULT

TYPICAL WIRING DIAGRAM  
 SINGLE PHASE, CONDENSING SECTION

| TRANSFORMER PRIMARY LEAD CLR. |              |
|-------------------------------|--------------|
| 120                           | - WHI        |
| 208                           | - RED        |
| 240                           | - ORG        |
| 277                           | - BRN        |
| 360                           | - PUR OR YEL |
| 480                           | - BLK/RED    |
| 575                           | - GRY        |



FACTORY WIRE —————  
 FIELD WIRE - - - - -

STANDARD COMPONENTS LEGEND:  
 CC - COMPRESSOR CONTACTOR  
 CCH - CRANKCASE HTR (WHEN SUPPLIED)  
 HPS - HIGH PRESSURE SWITCH  
 LPS - LOW PRESSURE SWITCH  
 RV - REVERSING VLV (HEAT PUMPS)

OPTIONAL COMPONENTS LEGEND:  
 [ ] AUX - AUXILIARY RELAY (FOR LOOP PUMP, ETC.)  
 [ ] CMFR - COMPR MALFUNCTION RELAY  
 [ ] CMR - COMPR MONITOR RELAY  
 [ ] FS - FREEZE SENSOR  
 [ ] HRP - HEAT RECOVERY PACKAGE, INCLUDES: HRPMP - HEAT RECOVERY PUMP MOTOR  
 HWL - HOT WATER LIMIT (120 OR 140 DEG)  
 SWT - ON/OFF SWITCH AND OVERLOAD PROTECTION

LINE VOLTAGE  
 NOTES (1), (2) & (5)

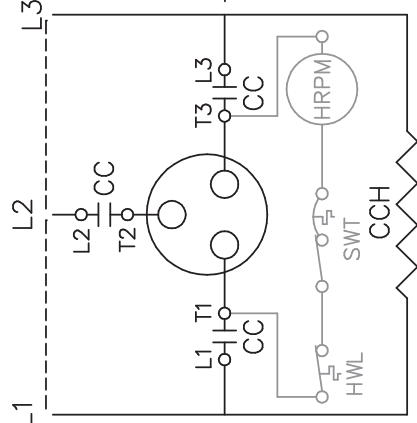

CONNECT TO FHP AIR HANDLING UNIT

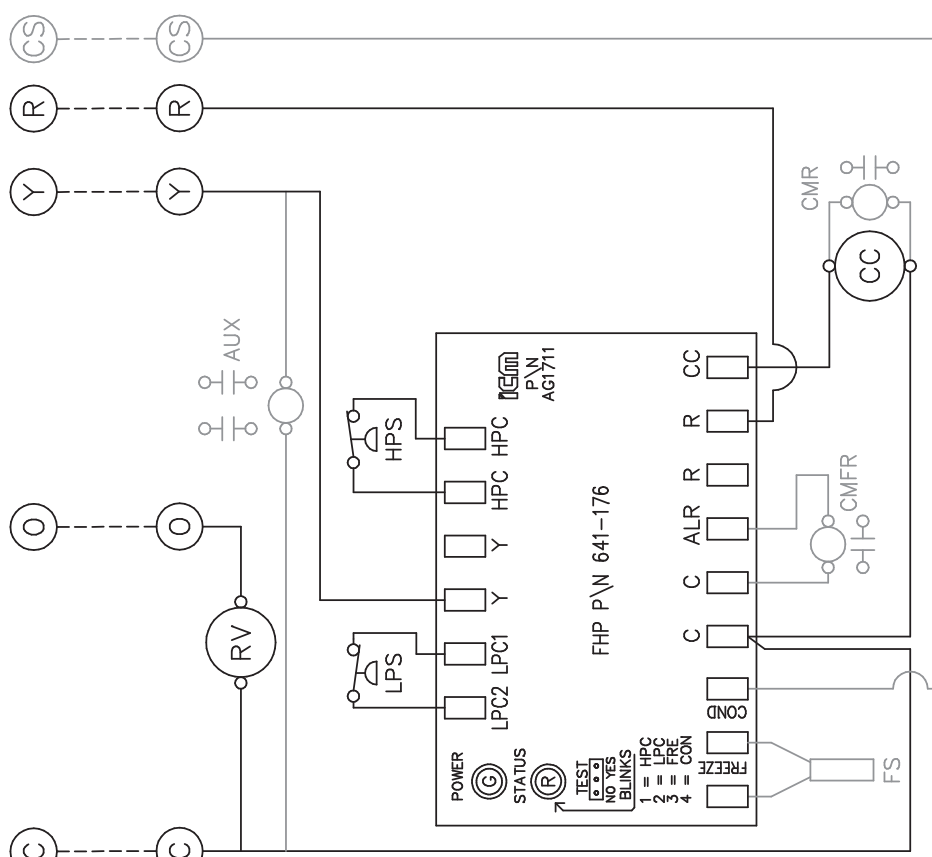

- NOTES:
- SEE UNIT NAME PLATE FOR ELECTRICAL RATING
  - ALL FIELD WIRING MUST BE IN ACCORDANCE WITH N.E.C.-N.F.P.A. #70, COPPER CONDUCTORS ONLY
  - 208/230V UNITS ARE FACTORY WIRED FOR 230V OPERATION. FOR 208V OPERATION, REMOVE ORG LEAD AND REPLACE WITH RED LEAD. CAP ALL UNUSED LEADS
  - CHECK PHASE ROTATION ON UNITS WITH SCROLL COMPRS. REVERSE ROTATION CAN DAMAGE COMPR.
  - UPM INCLUDES BUILT IN: 30-60 SECOND RANDOM START  
 5 MINUTE DELAY ON BREAK  
 90 SECOND LOW PRESSURE BYPASS
  - SETTING THE TEST MODE JUMPER TO YES REDUCES ALL TIME DELAYS TO 5 SECONDS.
  - "FREEZE" PINS ON UPM MUST BE JUMPED TOGETHER IF FREEZE SENSOR IS NOT INSTALLED.
  - BLINK CODES FOR HARD LOCK OUT: 1 - HIGH PRESSURE FAULT  
 2 - LOW PRESSURE FAULT  
 3 - FREEZE FAULT  
 4 - CONDENSATE FAULT

TYPICAL WIRING DIAGRAM  
 THREE PHASE CONDENSING SECTION

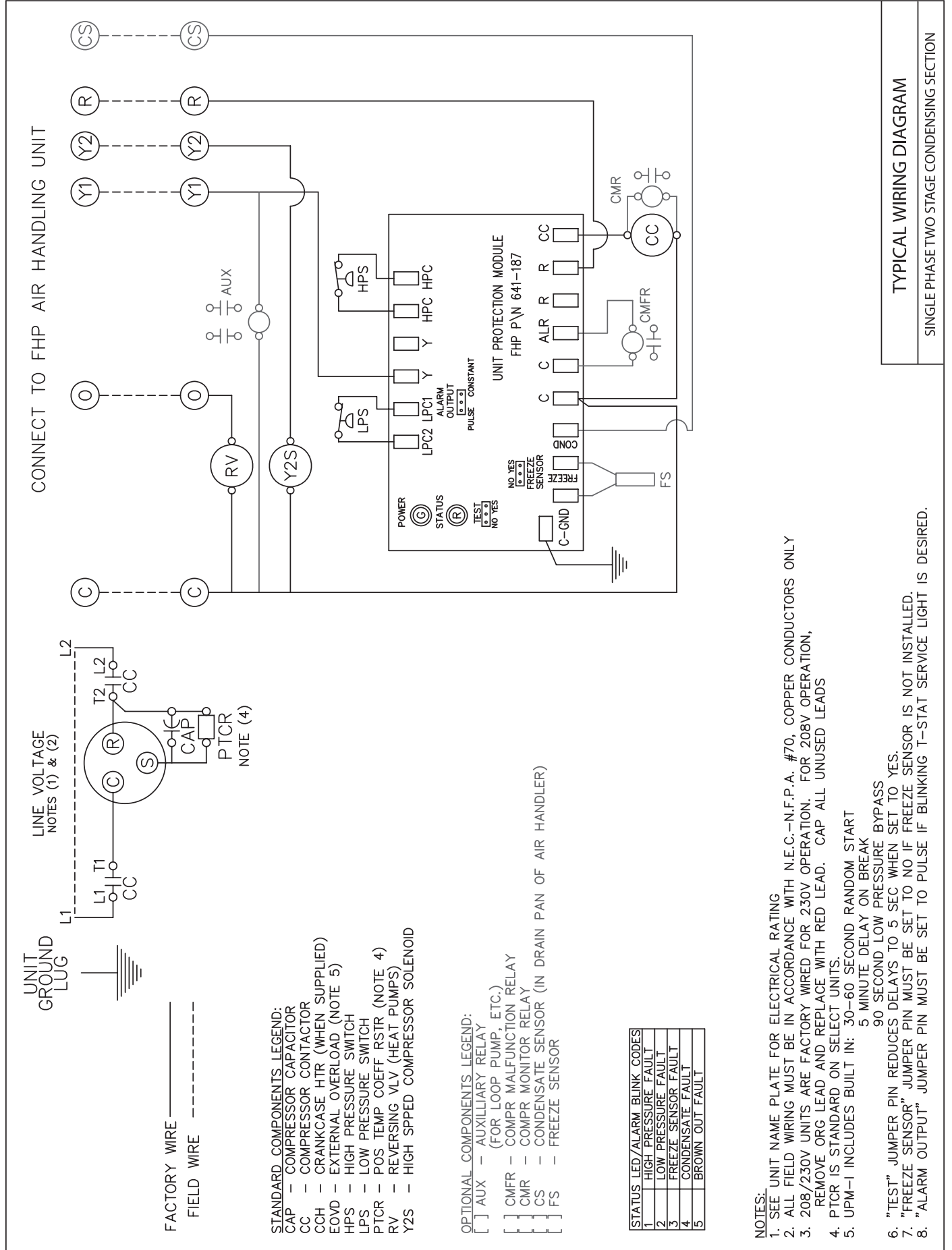

NOTES:  
 1. SEE UNIT NAME PLATE FOR ELECTRICAL RATING  
 2. ALL FIELD WIRING MUST BE IN ACCORDANCE WITH N.E.C.—N.F.P.A. #70

STANDARD COMPONENTS LEGEND:  
 BM — BLOWER MOTOR

OPTIONAL COMPONENTS LEGEND:  
 [ ] CBR — 24V CIRCUIT BREAKER  
 [ ] CS — CONDENSATE SENSOR (IN UNIT DRAIN PAN)

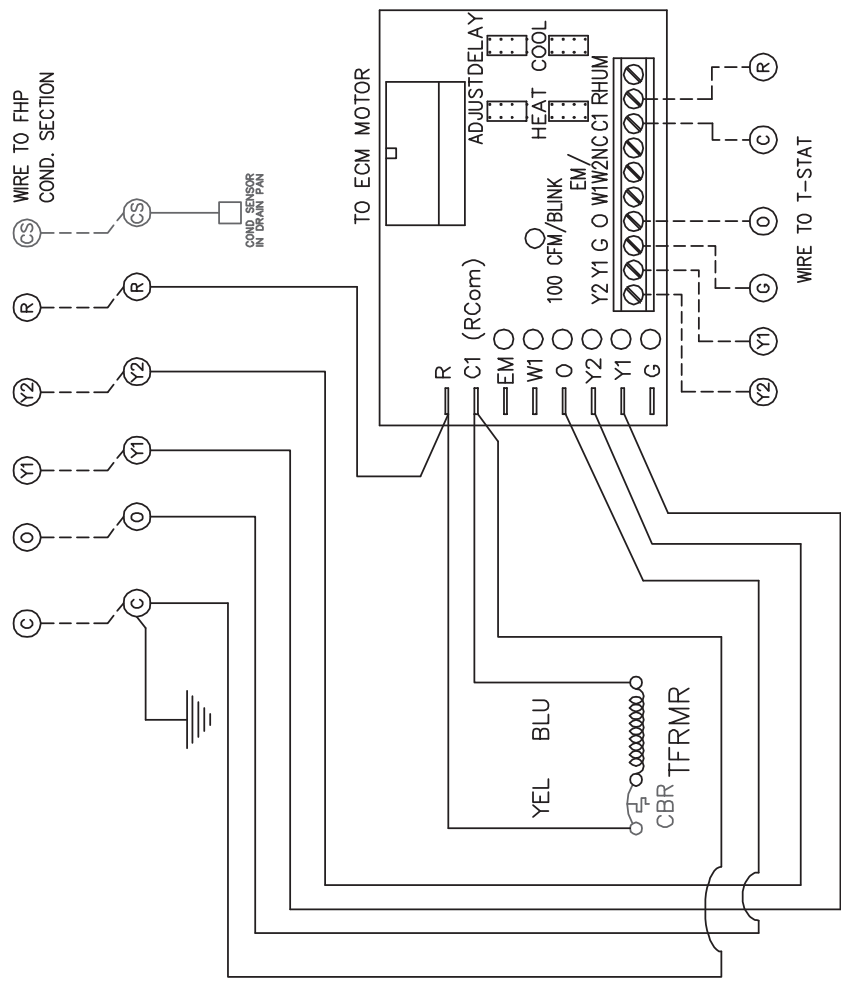
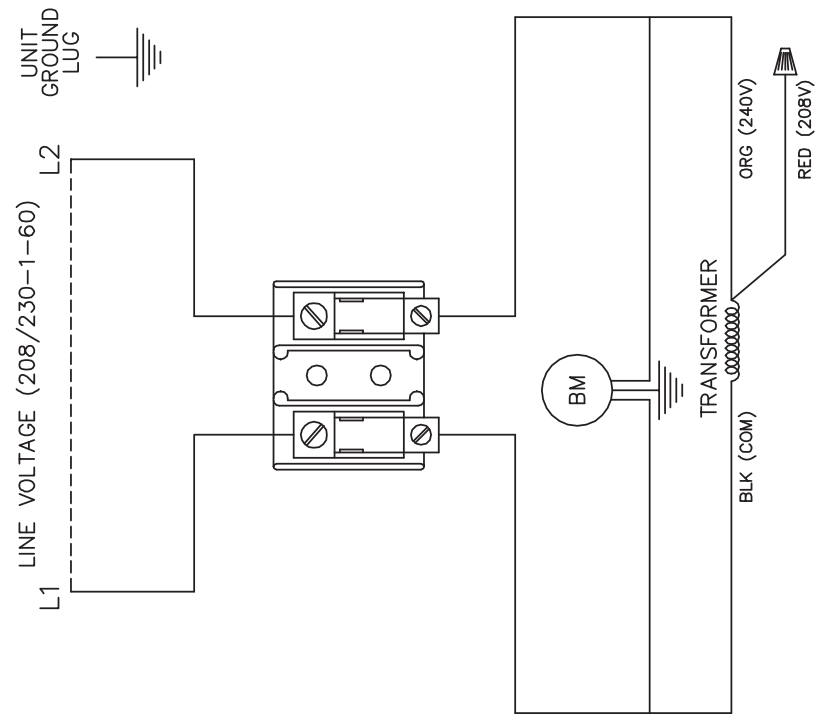

TYPICAL WIRING DIAGRAM

SINGLE PHASE TWO STAGE AIR HANDLING UNIT



**TROUBLE SHOOTING**

| PROBLEM  | POSSIBLE CAUSE  | CHECKS AND CORRECTIONS  |
|--|---|---|
| <b>ENTIRE UNIT DOES NOT RUN</b>                | Power supply off  | Apply power, close disconnect   |
|  | Blown fuse  | Replace fuse or reset circuit breaker. Check for correct fuses.   |
|  | Broken or loose wires   | Replace or tighten the wires.   |
|  | Voltage supply low  | If voltage is below minimum voltage specified on unit data plate, contact local power company.  |
|  | Thermostat  | Set the fan to "ON", the fan should run. Set thermostat to "COOL" and lowest temperature setting, the unit should run in the cooling mode (reversing valve energized). Set unit to "HEAT" and the highest temperature setting, the unit should run in the heating mode. If neither the blower or compressor run in all three cases, the thermostat could be miswired or faulty. To ensure miswired or faulty thermostat verify 24 volts is available on the condensing section low voltage terminal strip between "R" and "C", "Y" and "C", and "O" and "C". If the blower does not operate, verify 24 volts between terminals "G" and "C" in the air handler. Replace the thermostat if defective. |
| <b>BLOWER OPERATES BUT COMPRESSOR DOES NOT</b> | Thermostat  | Check setting, calibration, and wiring.   |
|  | Wiring  | Check for loose or broken wires at compressor, capacitor, or contactor.   |
|  | Safety controls   | Reset the thermostat to "OFF". After a few minutes turn to "COOL" or "HEAT". If the compressor runs, unit was off on one of the safety controls. (see problem for possible causes)  |
|  | Compressor overload open  | If the compressor is cool and the overload will not reset, replace compressor.  |
|  | Compressor motor grounded   | Internal winding grounded to the compressor shell. Replace compressor. If compressor burnout, install suction filter dryer.   |
|  | Compressor windings open  | After compressor has cooled, check continuity of the compressor windings. If the windings are open, replace the compressor.   |
| <b>UNIT OFF ON HIGH PRESSURE CONTROL</b>       | Discharge pressure too high   | In "COOLING" mode: Lack of or inadequate water flow. Entering water temperature too warm. Scaled or plugged condenser.  |
|  | Refrigerant charge  | The unit is overcharged with refrigerant. Reclaim refrigerant, evacuate and recharge with factory recommended charge.   |
|  | High pressure   | Check for defective or improperly calibrated high pressure switch.  |
| <b>UNIT OFF ON LOW PRESSURE CONTROL</b>        | Suction pressure too low  | In "COOLING" mode: Lack of or inadequate air flow. Entering air temperature too cold. Blower inoperative, clogged filter, or restrictions in ductwork.<br>In "HEATING" mode: Lack of or inadequate water flow. Entering water temperature too cold. Scaled or plugged condenser.  |
|  | Refrigerant charge  | The unit is low on refrigerant. Check for refrigerant leak, repair, evacuate and recharge with factory recommended charge.  |
|  | Low pressure switch   | Check for defective or improperly calibrated low pressure switch.   |
| <b>UNIT SHORT CYCLES</b>                       | Unit oversized  | Recalculate heating and or cooling loads.   |
|  | Thermostat  | Thermostat installed near a supply air grill, relocate thermostat. Readjust heat anticipator.   |
|  | Wiring and controls   | Loose connections in the wiring or a defective compressor contactor.  |
| <b>INSUFFICIENT COOLING OR HEATING</b>         | Unit undersized   | Recalculate heating and or cooling loads. If excessive, possibly adding insulation and shading will rectify the problem.  |
|  | Loss of conditioned air by leaks  | Check for leaks in duct work or introduction of ambient air through doors or windows.   |
|  | Airflow   | Lack of adequate air flow or improper distribution of air. Replace dirty filter.  |
|  | Refrigerant charge  | Low on refrigerant charge causing inefficient operation.  |
|  | Compressor  | Check for defective compressor. If discharge is too low and suction pressure is too high, compressor is not pumping properly. Replace compressor.   |
|  | Reversing valve   | Defective reversing valve creating bypass of refrigerant from discharge to suction side of compressor. Replace reversing valve.   |
|  | Operating pressures   | Compare unit operating pressures to the pressure / temperature chart for the unit.  |
|  | Capillary Tubes / TXV   | Check metering device for possible restriction. Replace if necessary.   |
| Moisture, noncondensables                      | The refrigerant system may be contaminated with moisture or noncondensables. Reclaim refrigerant, evacuate and recharge with factory recommended charge. Note: a liquid line dryer may be required. |   |





