

**MODELS D1EE180 & 240
(9.5 EER)**

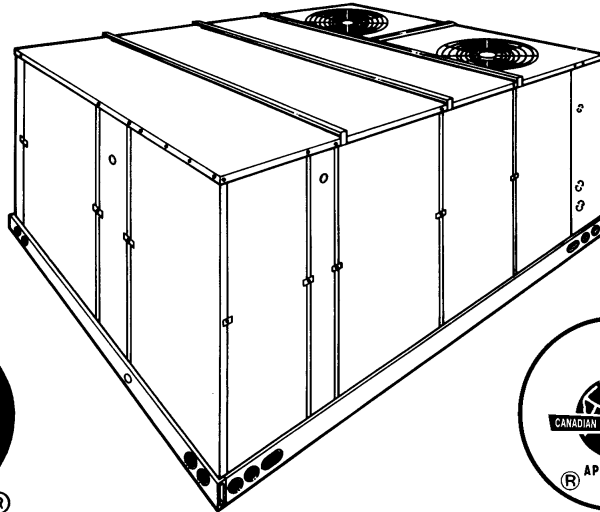

GENERAL

YORK Model DEE units are single package air conditioners designed for outdoor installation on a rooftop or a slab. These units can be equipped with factory installed electric heaters for cooling/heating applications.

The units are completely assembled on rigid, permanently attached base rails. All piping, refrigerant charge, and electrical wiring is factory installed and tested. The units require electric power, duct connections and installation of fixed outdoor air intake damper (units without economizer or motorized damper option only) at the point of installation.

The supplemental electric heaters have nickel-chrome elements and utilize single point power connection.

INSPECTION

As soon as a unit is received, it should be inspected for possible damage during transit. If damage is evident, the extent of the damage should be noted on the carrier's freight bill. A separate request for inspection by the carrier's agent should be made in writing. Refer to Form 50.15-NM for additional information.

REFERENCE

Additional information on the design, installation, operation and service of this equipment is available in the following reference forms:

- 55.70-N1 - General Installation
- 55.70-N2 - Pre-start & Post-start Check List
- 44-320-10 - Barometric Relief Damper Accessory

Renewal Parts:

- Refer to the Renewal Parts Manual for complete listing of replacement parts on this equipment.

All forms referenced in this instruction may be ordered from:

**Publications Distribution Center
Unitary Products Group
P.O. Box 1592, York, Pa. 17405**

APPROVALS

Design certified by ETL & CGA as follows:

1. For use as a central cooling only unit with or without supplemental electric heat.
2. For outdoor installation only.
3. For installation on combustible material.

CAUTION

THIS PRODUCT MUST BE INSTALLED IN STRICT COMPLIANCE WITH THE ENCLOSED INSTALLATION INSTRUCTIONS AND ANY APPLICABLE LOCAL, STATE, AND NATIONAL CODES INCLUDING, BUT NOT LIMITED TO, BUILDING, ELECTRICAL, AND MECHANICAL CODES.

WARNING

INCORRECT INSTALLATION MAY CREATE A CONDITION WHERE THE OPERATION OF THE PRODUCT COULD CAUSE PERSONAL INJURY OR PROPERTY DAMAGE

Installer should pay particular attention to the words: *NOTE*, *CAUTION* and *WARNING*. Notes are intended to clarify or make the installation easier. Cautions are given to prevent equipment damage. Warnings are given to alert installer that personal injury and/or equipment damage may result if installation procedure is not handled properly.

TABLE OF CONTENTS

General 1
 Inspection..... 1
 Reference..... 1
 Approvals..... 1
 Nomenclature..... 2

INSTALLATION

Limitations..... 3
 Location 3
 Rigging and Handling 3
 Clearances..... 3
 Ductwork..... 3
 Fixed Outdoor Air Intake Damper 4
 Condensate Drain..... 4
 Compressors..... 4
 Filters 4
 Service Access 4
 Thermostat..... 4
 Power and Control Wiring 4
 Optional Electric Heaters..... 5
 Optional Economizer/Mot. Damper Rain Hood 5
 Optional Power Exhaust Rain Hood 7

OPERATION

Cooling System..... 14
 Preliminary Operation Cooling..... 14
 Cooling Sequence of Operation..... 14
 Safety Controls 14
 Heating Sequence of Operation 14
 Heat Anticipator Setpoints 15
 Checking Supply Air CFM..... 15
 Secure Owner's Approval 16

MAINTENANCE

Normal Maintenance 16

TABLES

No.	Description	Page
1	Unit Application Data	3
2	Control Wiring Sizes	5
3	Electric Heat Application Data.....	5
4	Physical Data.....	8
5	Supply Air Blower Perf. 15 Ton.....	10
6	Supply Air Blower Perf. 20 Ton.....	11
7	Static Resistances	12
8	Power Exhaust Performance	12
9	Blower Motor and Drive Data.....	12
10	Electrical Data (Basic Units).....	13
11	Electrical Data (Units w/Elec. Heat).....	13
12	Heat Anticipator Setpoints	15

FIGURES

No.	Description	Page
1	Typical Rigging.....	3
2	Center of Gravity.....	3
3	Fixed Outdoor Air Damper.....	4
4	Recommended Drain Piping.....	4
5	Typical Field Wiring.....	5
6	Adjusting Enthalpy Setpoint.....	7
7	Dimensions and Clearances.....	9
8	Belt Adjustment.....	15
9	Pressure Drop versus Supply Air CFM	15

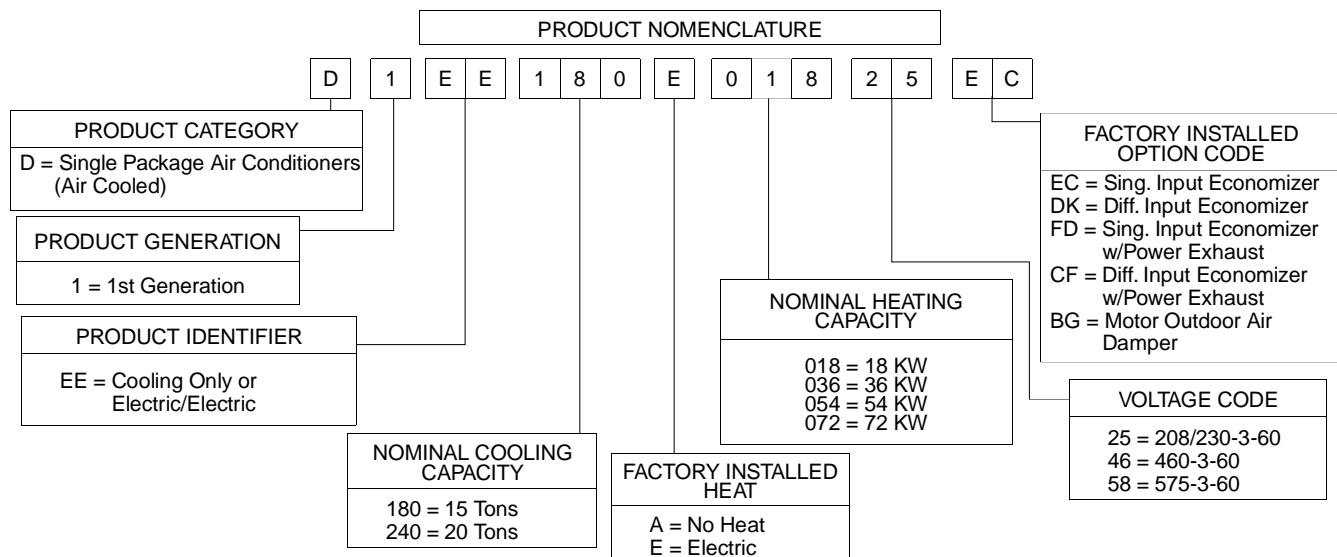

INSTALLATION

LIMITATIONS

These units must be installed in accordance with the following national and local safety codes:

In U.S.A.:

1. National Electrical Code ANSI/NFPA No. 70.
2. Local electric utility requirements.

In Canada:

1. Current Canadian Electrical Code CSA C22.1.
2. Local electrical codes.

Refer to Table 1 for Unit Application Data and to Table 2 for Electric Heat Application Data.

If components are to be added to a unit to meet local codes, they are to be installed at the dealer's and/or the customer's expense.

Size of unit for proposed installation should be based on heat loss/heat gain calculation made according to the methods of the Air Conditioning Contractors of America (ACCA).

TABLE 1 - UNIT APPLICATION DATA

Model Size		15 TON	20 TON
Voltage Variation, Min. / Max. ¹	208/230-3-60	187 / 253	
	460-3-60	414 / 506	
	575-3-60	518 / 630	
Supply Air CFM, Min. / Max.		4500 ² / 7200	6000 / 9400
Wet Bulb Temperature (ÉF) of Air on Indoor Coil Min. / Max.		57 / 72	
Dry Bulb Temperature (ÉF) of Air on Outdoor Coil Min. / Max.		25 / 120	

¹Utilization range "A" in accordance with ARI Standard 110.

²5,000 CFM on 15 ton models with either a 54 or 72 KW heater at 208/230 volts.

LOCATION

Use the following guidelines to select a suitable location for these units.

1. Unit is designed for outdoor installation only.
2. Outdoor coils must have an unlimited supply of air. Where a choice of location is possible, position the unit on either north or east side of building.
3. For ground level installation, use a level concrete slab with a minimum thickness of 4 inches. The length and width should be at least 6 inches greater than the unit base rail dimensions. Do not tie slab to the building foundation.
4. Roof structures must be able to support the weight of the unit and its options and/or accessories. Unit must be installed on a solid level roof curb or appropriate angle iron frame.

CAUTION: If a unit is to be installed on a roof curb or special frame other than a YORK roof curb, gasketing must be applied to all surfaces that come in contact with the unit underside.

5. Maintain level tolerance to 1/2" maximum across the entire length or width of the unit.

RIGGING AND HANDLING

Exercise care when moving the unit. Do not remove any packaging until the unit is near the place of installation. Rig the unit by attaching chain or cable slings to the round lifting holes provided in the base rails. Spreaders, whose length exceeds the larger dimension across the unit, **MUST** be used across the top of the unit. Refer to Figure 1.

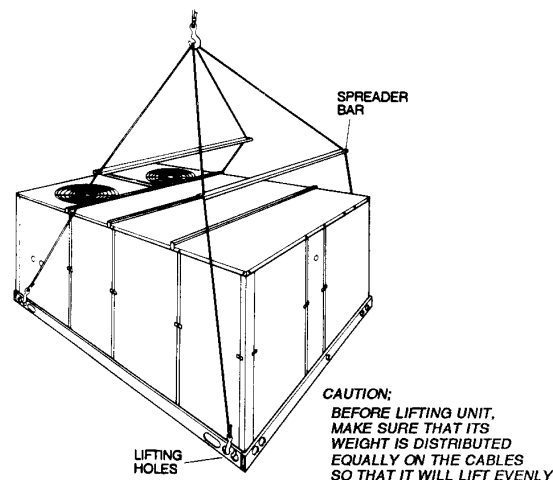

FIG. 1 - TYPICAL RIGGING

Units may also be moved or lifted with a forklift, from the front or rear only, providing that an accessory skid is used.

LENGTH OF FORKS MUST BE A MINIMUM OF 90".

Refer to Table 4 for unit weights and to Figure 2 for approximate center of gravity.

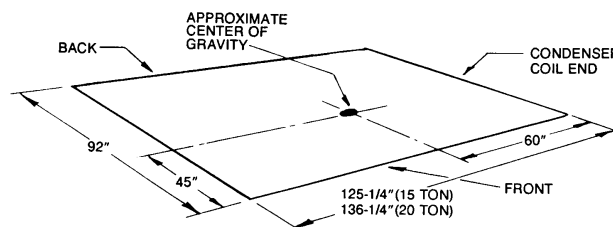

FIG. 2 - CENTER OF GRAVITY

CLEARANCES

All units require certain clearances for proper operation and service. Refer to Figure 9 for the clearances required for combustible construction, servicing, and proper unit operation.

WARNING: Do not permit overhanging structures or shrubs to obstruct outdoor air discharge outlet.

DUCTWORK

Ductwork should be designed and sized according to the methods in Manual Q of the Air Conditioning Contractors of America (ACCA).

A closed return duct system shall be used. This shall not preclude use of economizers or outdoor fresh air intake. The supply and return air duct connections at the unit should be made with flexible joints to minimize transmission of noise.

The supply and return air duct systems should be designed for the CFM and static requirements of the job. They should **NOT** be sized to match the dimensions of the duct connections on the unit.

CAUTION: When fastening ductwork to side duct flanges on the unit, insert screws through duct flanges only. **DO NOT** insert screws through casing.

Outdoor ductwork must be insulated and waterproofed.

Refer to Figure 9 for information concerning side and bottom supply and return air duct openings.

FIXED OUTDOOR AIR INTAKE DAMPER

This damper is shipped inside the return air compartment. It is completely assembled and ready for installation. A damper baffle inside the hood is adjustable to provide variable amounts of outdoor air intake on units that are not provided with an economizer or a motorized damper option. Refer to Figure 3.

Gasketing and mounting screws are provided in a parts bag attached to the hood assembly. Apply gasketing to the three flange surfaces on the hood prior to installing the hood. Extend gasketing 1/4" beyond the top and bottom of the two side flanges to insure adequate sealing.

Adjusting the damper to the desired air flow may be done before mounting the hood into position or (after installation) by removing the front hood panel or the screen on the bottom of the hood. Damper baffle in position 1 will allow approximately 10% recirculated air flow, position 2 approximately 15% and, to allow approximately 25%, remove the damper baffle.

On units with **bottom** return air applications, install the damper assembly over the opening in the side return air access panel. Remove and discard the opening cover and the covering over the hood mounting holes (used for shipping) before installing. Secure with the screws provided.

On units with **side** return air applications, install the damper assembly on the return air ductwork as close to the unit as possible. Cut an opening 16" high by 18" wide in the ductwork to accommodate the damper. Using the holes in the hood flanges as a template, drill 9/64" dia. (#26 drill) holes into the ductwork and secure with the screws provided.

CAUTION: If outdoor air intake will not be required on units with bottom return air applications, the damper assembly should still be mounted on the side return air access panel, per the instructions above, to insure moisture is not drawn into the unit during operation. The covering over the mounting holes only need be removed. Do not remove the opening cover.

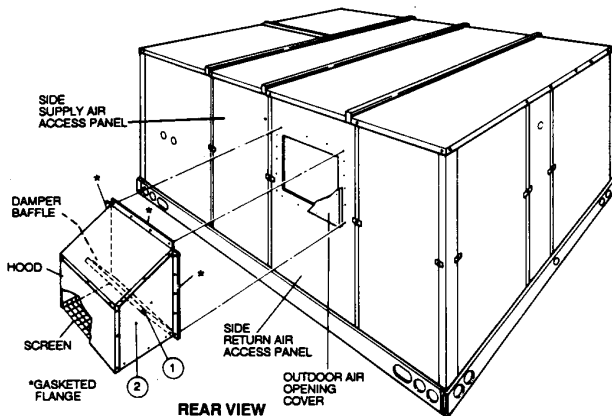

FIG. 3 - FIXED OUTDOOR AIR DAMPER

CONDENSATE DRAIN

Plumbing must conform to local codes. Use a sealing compound on male pipe threads. Install a condensate drain line from the 1" NPT female connection on the unit to an open drain.

An alternate drain connection (1" NPT female coupling) is provided inboard on the same centerline as the exterior location.

NOTE: The condensate drain operates in a negative pressure are in the cabinet. The condensate drain line **MUST** be trapped to provide proper drainage. See Figure 4.

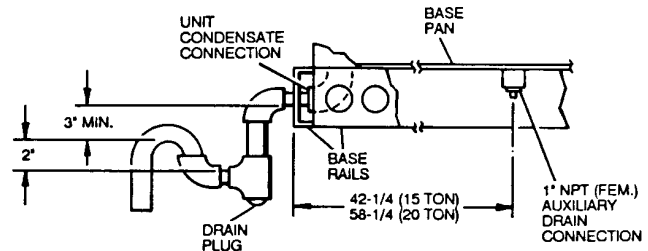

FIG. 4 - RECOMMENDED DRAIN PIPING

COMPRESSORS

Units are shipped with compressor mountings factory-adjusted and ready for operation.

CAUTION: Do Not loosen compressor mounting bolts.

FILTERS

2" filters are supplied with each unit. Filters must always be installed ahead of the indoor coil and must be kept clean or replaced with same size and type. Dirty filters will reduce the capacity of the unit and will result in frosted coils or safety shutdown. Minimum filter area and required sizes are shown in Table 4.

SERVICE ACCESS

Access to all serviceable components is provided by the following removable panels:

- Compressor compartment
- Electric Heat compartment
- Side Supply & Return Air compartments (Two panels)
- Blower compartment (Three panels)
- Main control box
- Filter compartment
- Outdoor Air compartment (Two panels)

Refer to Figure 9 for location of these access panels.

CAUTION: Make sure that all screws and panel latches are replaced and properly positioned on the unit to maintain an air-tight seal.

THERMOSTAT

The room thermostat should be located on an inside wall approximately 56" above the floor where it will not be subject to drafts, sun exposure or heat from electrical fixtures or appliances. Follow manufacturer's instructions enclosed with thermostat for general installation procedure. Color coded insulated wires (#18 AWG) should be used to connect thermostat to unit.

POWER AND CONTROL WIRING

Field wiring to the unit must conform to provisions of the National Electrical Code, ANSI / NFPA No. 70 (in U.S.A.), current Canadian Electric Code (CEC) CSA C22.1 (in Canada) and/or local ordinances. The unit must be electrically grounded in accordance with NEC and CEC (as specified above) and/or local codes. Voltage tolerances which must be maintained at the compressor terminals during starting and running conditions are indicated on the unit Rating Plate and Table 1.

The internal wiring harness furnished with this unit is an integral part of a ETL and CGA design certified unit. Field alteration to comply with electrical codes should not be required.

CONTROL WIRING

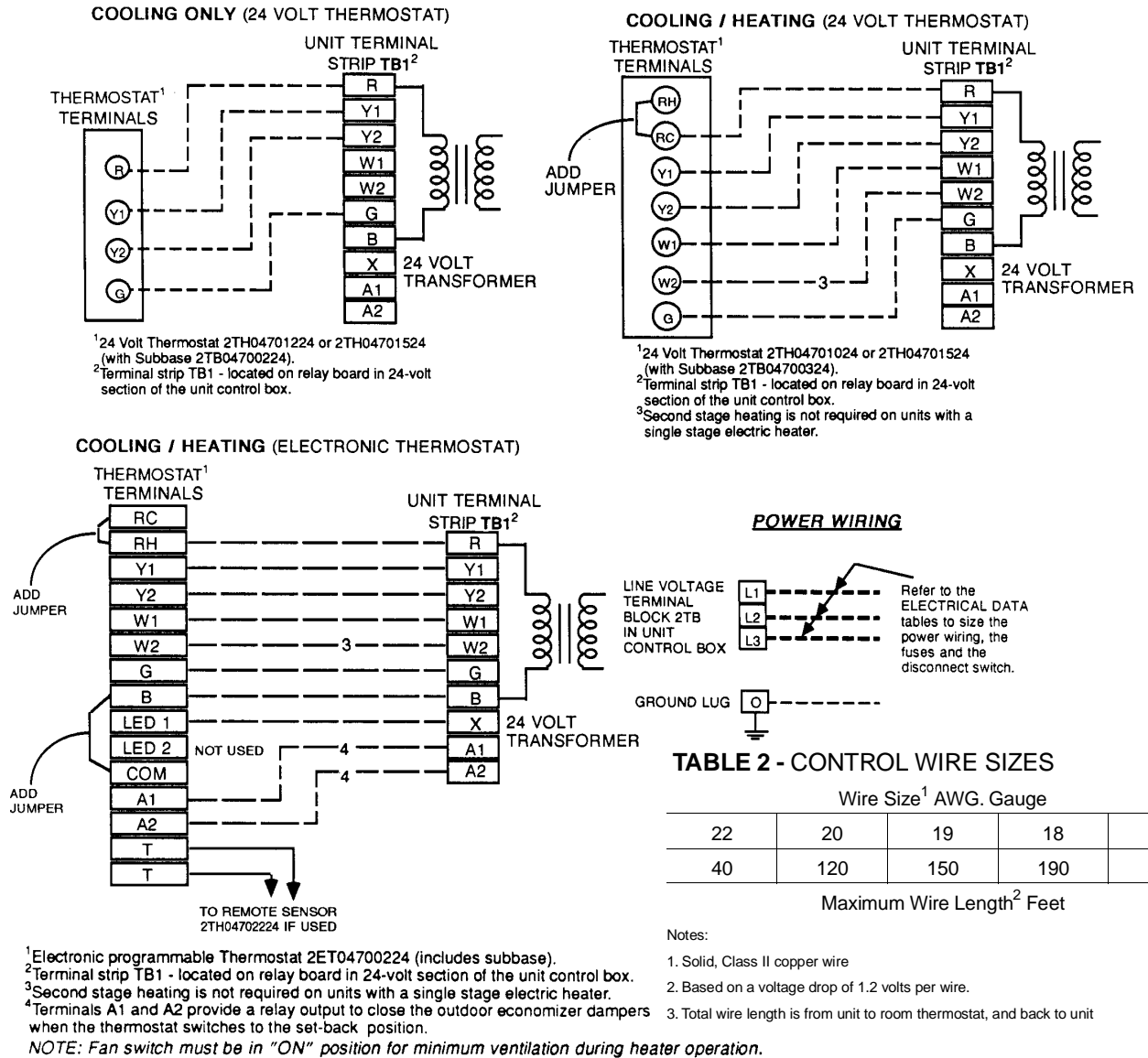

A fused disconnect switch should be field provided for the unit. The switch must be separate from all other circuits. Wire entry at knockout openings require conduit fittings to comply with CEC (in Canada), NEC (in U.S.A.) and/or local codes. Refer to Figure 9 for installation location. If any of the wire supplied with the unit must be replaced, replacement wire must be of the type shown on the wiring diagram and the same minimum gauge as the replaced wire.

Electrical line must be sized properly to carry the load. Each unit must be wired with a separate branch circuit fed directly from the meter panel and properly fused.

CAUTION: When connecting electrical power and control wiring to the unit, waterproof type connectors **MUST BE USED** so that water or moisture cannot be drawn into the unit during normal operation. The above waterproofing conditions will also apply when installing a field-supplied disconnect switch.

Refer to Figure 5 for typical field wiring and to the appropriate unit wiring diagram for control circuit and power wiring information.

OPTIONAL ELECTRIC HEATERS

The factory installed heaters are wired for single point power supply. Power supply need only be brought into the single point terminal block and thermostat wiring to the low voltage terminal strip located in the upper portion of the unit control box.

These ETL and CGA approved heaters are located within the central compartment of the unit with the heater elements extending into the supply air chamber. Refer to Figure 9 for access panel location.

TABLE 3 - ELECTRIC HEAT APPLICATION DATA

NOMINAL HEATER SIZE (KW)	VOLTAGE 3 PHASE, 60 HZ	MINIMUM CFM (UNIT SIZE)	
		15 TON	20 TON
18	208/230,460,575	4500	6000
36	208/230,460,575	4500	6000
54	208/230	5000	6000
	460, 575	4500	
72	208/230	5000	6000
	460, 575	4500	

OPTIONAL ECONOMIZER/MOTORIZED DAMPER RAIN HOOD

The instruction for the optional economizer/motorized damper rain hood can be found in form 44-320-2. Use these instructions when field assembling an economizer rain hood onto a unit. The outdoor and return air dampers, the damper actuator, the damper linkage, the outdoor and return air divider baffles, and all the control sensors are factory mounted as part of the "Factory installed" economizer option.

ENTHALPY SET POINT ADJUSTMENT

Remove the economizer access panel from the unit to check the following adjustments. Loosen but do not remove the two panel latches.

CAUTION: Extreme care must be exercised in turning both the setpoint and minimum position adjusting screws to prevent twisting them off.

6. The enthalpy set point may now be set by selecting the desired setpoint shown in Figure 8. Adjust as follows:
 - For a single enthalpy operation, carefully turn the set point adjusting screw to the "A", "B", "C" or "D" setting corresponding to the lettered curve.

- For a dual enthalpy operation, carefully turn the set point adjusting screw fully clockwise past the "D" setting.

7. To check that the damper blades move smoothly without binding, carefully turn the minimum position adjusting screw fully clockwise and then energize and de-energize terminals "R" to "G". With terminals "R" to "G" energized, turn the minimum position screw counterclockwise until the desired minimum position has been attained.

8. Replace the economizer access panel. Reposition the two latches horizontally and retighten the screws.

POWER EXHAUST/BAROMETRIC RELIEF DAMPER AND RAIN HOOD OPTION

The instructions for the power exhaust/barometric relief damper and rain hood can be found in form 44-320-10. The exhaust fan, all supporting brackets, angles, and the wiring are factory installed as part of the power exhaust option.

All of the components, including the dampers, hardware, and mounting instructions are shipped in a single package external from the unit. The hood must be field assembled and installed.

Power exhaust is not available as a field installed option.

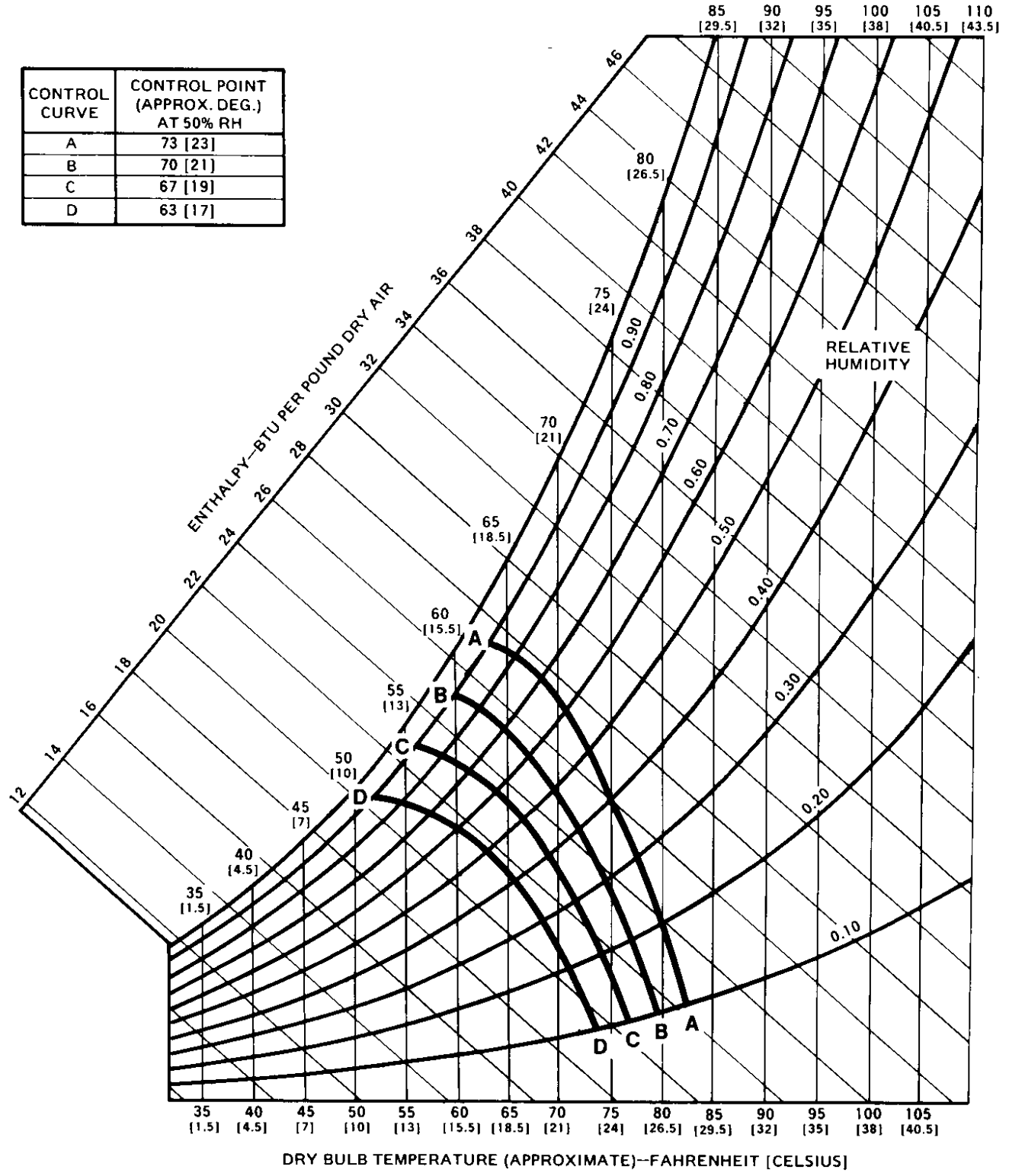

FIG. 6 - ENTHALPY SETPOINT ADJUSTMENT

TABLE 3 - PHYSICAL DATA

MODELS		UNIT SIZE		
		15 TON	20 TON	
SUPPLY AIR BLOWER	CENTRIFUGAL BLOWER (Dia. x Wd. in.)	15 x 15	18 x 15	
	FAN MOTOR HP	5	7.5	
EVAPORATOR COIL	ROWS DEEP	4	4	
	FINS PER INCH	13.5	13.5	
	FACE AREA (Sq. Ft.)	15.5	20.5	
CONDENSER FANS (Two Per Unit)	PROPELLER DIA. (in.) (Each)	30	30	
	FAN MOTOR HP (Each)	1	1	
	NOM. CFM (Each)	6500	7200	
CONDENSER COILS (Two Per Unit)	ROWS DEEP (Each)	2	2	
	FINS PER INCH (Each)	13	20	
	FACE AREA (Sq. Ft.) (Total)	36.0	43.3	
COMPRESSOR (Qty. Per Unit)	10 TON TANDEM	1*	2	
	5 TON HERMETIC	1	-	
AIR FILTERS	QUANTITY PER UNIT (16" X 20" X 2")	-	4	
	QUANTITY PER UNIT (16" X 25" X 2")	-	4	
	QUANTITY PER UNIT (18" X 24" X 2")	5	-	
	TOTAL FACE AREA (sq. ft.)	15.0	20.0	
CHARGE	REFRIGERANT 22 (lbs./oz.)	SYSTEM NO. 1	20/8	18/8
		SYSTEM NO. 2	10/8	18/8

OPERATING WEIGHTS (LBS.)		15 TON	20 TON	
Basic Unit	Cooling Only	1900	2100	
Options	Economizer	160		
	Economizer with Power Exhaust	245		
	Motorized Damper	150		
	Electric Heat (Nominal KW)	18 KW	25	
		36 KW	30	
		54 KW	35	
72 KW		40		
Accessories	Roof Curb	175	185	
	Barometric Damper	45	45	
	Wood Skid	200	220	

*This compressor will be energized first.

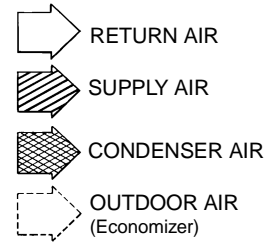
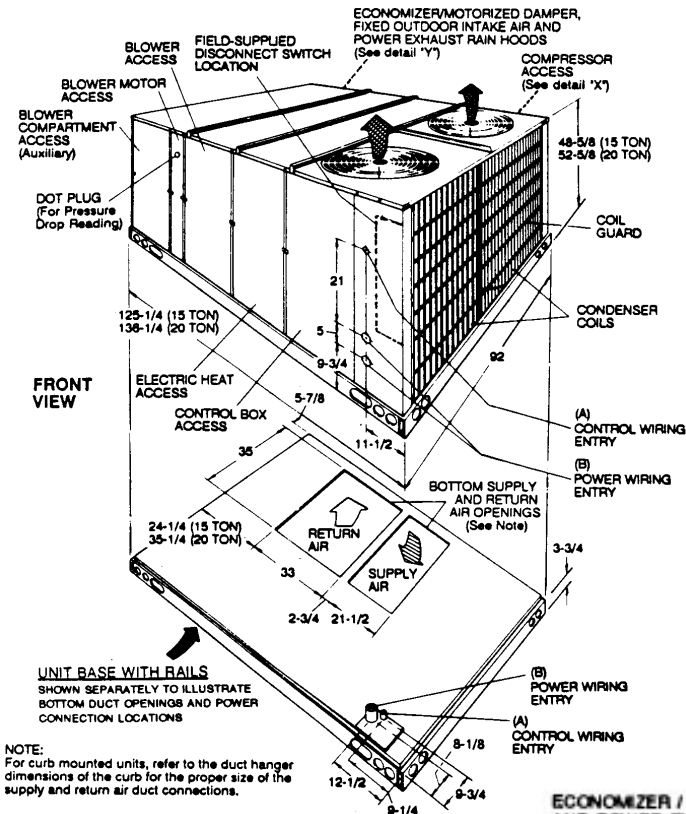

All dimensions are in inches. They are subject to change without notice. Certified dimensions will be provided upon request.

UTILITIES ENTRY DATA

HOLE	OPENING SIZE (DIA.)	USED FOR	
A	1-1/8" KO	Control Wiring	Front
	3/4" NPS (Fem.)	Wiring	Bottom
B	3-5/8" KO	Power Wiring	Front
	3" NPS (Fem.)	Wiring	Bottom

DUCT COVERS - Units are shipped with the bottom duct openings covered. An accessory flange kit is available for connecting side ducts.

For **bottom** duct applications:

1. Remove the side panels from the supply and return air compartments to gain access to the bottom supply and return air duct covers.
2. Remove and discard the bottom duct covers. (Duct openings are closed with sheet metal covers except when the unit includes a power exhaust option. The covering consists of a heavy black paper composition.)
3. Replace the side supply and return air compartment panels.

For **side** duct applications:

1. Replace the side panels on the supply and return air compartments with the accessory flange kit panels.
2. Connect ductwork to the duct flanges on the rear of the unit.

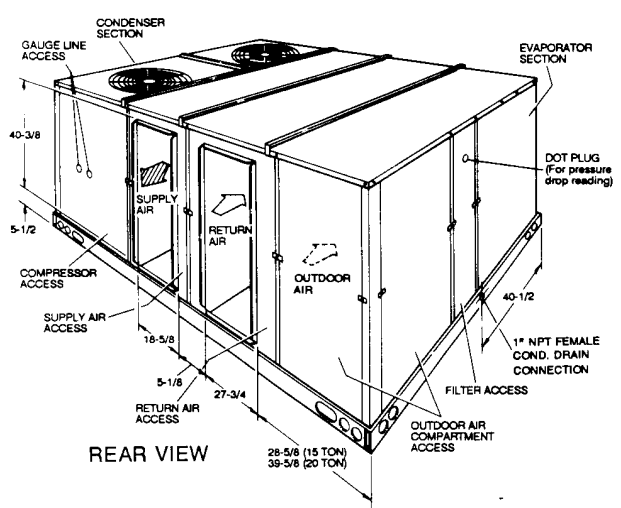
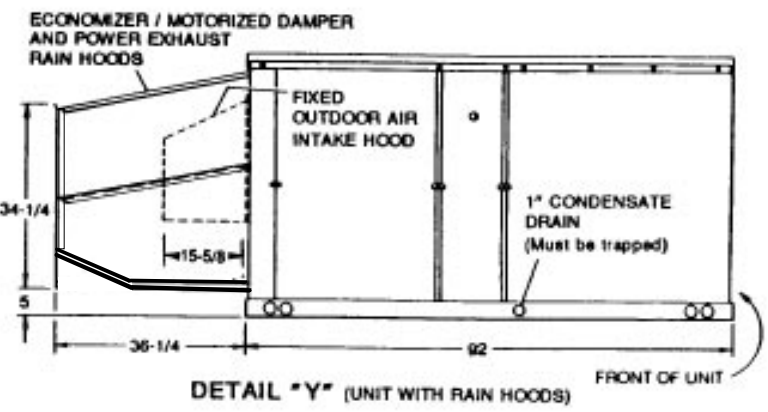

DETAIL "X" (ACCESSORY SIDE SUPPLY AND RETURN AIR OPENINGS)

FIG. 7 - DIMENSIONS & CLEARANCES - 15 & 20 TON

CLEARANCES

Front	36"
Back	24" (Less Economizer) 49" (With Economizer)
Left Side (Filter Access)	24" (Less Economizer) 54" (With Economizer)
Right Side (Cond. Coil)	36"
Below Unit ¹	0"
Above Unit ²	72" With 36" Maximum Horizontal Overhang (For Condenser Air Discharge Outlet)

NOTE: Unit and ductwork are approved for zero clearance to combustible materials when equipped with electric heat.

¹Units (applicable in U.S.A. only) may be installed on combustible floors made from wood or class A, B or C roof covering material.

²Units must be installed outdoors. Overhanging structures or shrubs should not obstruct condenser air discharge outlet.

TABLE 4 - SUPPLY AIR BLOWER PERFORMANCE (15 TON)**BOTTOM DUCT CONNECTIONS**

BLOWER SPEED, (RPM)	MOTOR PULLEY (TURNS OPEN)*	CFM														
		4500			5250			6000			6750			7200		
		ESP	BHP	KW	ESP	BHP	KW	ESP	BHP	KW	ESP	BHP	KW	ESP	BHP	KW
208 VOLT AND STANDARD DRIVE																
850	6.0**	0.9	2.4	2.2	0.7	3.0	2.7	0.5	3.2	2.9	-	-	-	-	-	-
870	5.5	1.0	2.5	2.3	0.8	3.1	2.8	0.6	3.5	3.1	0.2	4.1	3.7	-	-	-
915	4.5	1.1	2.6	2.4	0.9	3.4	3.0	0.7	3.7	3.3	0.3	4.4	3.9	0.2	4.5	4.0
965	3.5	1.2	2.9	2.6	1.0	3.6	3.2	0.8	4.0	3.6	0.5	4.7	4.2	0.4	4.9	4.4
980	3.0	1.3	3.0	2.7	1.1	3.7	3.3	0.9	4.1	3.7	0.6	4.8	4.3	0.5	5.1	4.6
1010	2.0	1.4	3.1	2.8	1.2	3.8	3.4	1.0	4.2	3.8	0.7	5.0	4.5	0.6	5.4	4.8
1040	1.0	1.5	3.2	2.9	1.3	3.9	3.5	1.1	4.5	4.0	0.9	5.2	4.7	0.7	5.7	5.1
208 VOLT AND HIGH SPEED DRIVE ACCESSORY																
965	6.0	1.2	2.9	2.6	1.0	3.6	3.2	0.8	4.0	3.6	0.5	4.7	4.2	0.4	5.0	4.4
980	5.5	1.3	3.0	2.7	1.1	3.7	3.3	0.9	4.1	3.7	0.6	4.8	4.3	0.5	5.1	4.6
1025	4.5	1.5	3.2	2.9	1.3	3.9	3.5	1.1	4.5	4.0	0.8	5.1	4.6	0.7	5.6	5.0
1065	3.5	1.6	3.4	3.0	1.4	4.0	3.6	1.2	4.7	4.2	1.0	5.5	4.9	-	-	-
1095	3.0	1.7	3.5	3.1	1.5	4.2	3.8	1.3	4.9	4.4	1.2	5.7	5.1	-	-	-
1130	2.0	1.9	3.7	3.3	1.7	4.5	4.0	1.5	5.1	4.6	-	-	-	-	-	-
1170	1.0	2.1	3.9	3.5	2.0	4.7	4.2	1.8	5.5	4.9	-	-	-	-	-	-
230/460/575 VOLT AND STANDARD DRIVE																
870	6.0**	1.0	2.4	2.2	0.8	3.1	2.8	0.6	3.5	3.1	0.2	4.1	3.7	-	-	-
915	5.0	1.1	2.6	2.4	0.9	3.3	3.0	0.7	3.7	3.3	0.3	4.4	3.9	0.2	4.5	4.0
965	4.0	1.2	2.9	2.6	1.0	3.6	3.2	0.8	4.0	3.6	0.5	4.7	4.2	0.4	5.0	4.4
980	3.5	1.3	3.0	2.7	1.1	3.7	3.3	0.9	4.1	3.7	0.6	4.8	4.3	0.5	5.1	4.6
1040	2.0	1.5	3.2	2.9	1.3	3.9	3.5	1.1	4.5	4.0	0.9	5.3	4.7	0.7	5.7	5.1
1065	1.0	1.6	3.3	3.0	1.4	4.0	3.6	1.2	4.7	4.2	1.0	5.5	4.9	-	-	-
230/460/575 VOLT AND HIGH SPEED DRIVE ACCESSORY																
980	6.0	1.3	2.9	2.6	1.1	3.7	3.3	0.9	4.1	3.7	0.6	4.8	4.3	0.5	5.1	4.6
1040	4.5	1.5	3.2	2.9	1.3	3.9	3.5	1.1	4.5	4.0	0.9	5.3	4.7	0.7	5.7	5.1
1065	4.0	1.6	3.4	3.0	1.4	4.0	3.6	1.2	4.7	4.2	1.0	5.5	4.9	-	-	-
1095	3.5	1.7	3.5	3.1	1.5	4.2	3.8	1.3	4.9	4.4	1.2	5.7	5.1	-	-	-
1130	2.5	1.9	3.7	3.3	1.7	4.5	4.0	1.5	5.1	4.6	-	-	-	-	-	-
1170	1.5	2.1	3.9	3.5	2.0	4.7	4.2	1.8	5.5	4.9	-	-	-	-	-	-
1190	1.0	2.2	4.0	3.6	2.1	4.8	4.3	2.0	5.7	5.1	-	-	-	-	-	-

NOTES: 1. Blower performance includes fixed outdoor air, 2" T/A filters, a dry evaporator coil and no electric heat.

2. Refer to Page 12 for additional static resistances.

ESP = External Static Pressure available for the supply and return air duct system. All internal unit resistances have been deducted from the total static pressure of the blower.

* Do **NOT** close the pulley below 1 turn open.

** Factory setting.

TABLE 5 - SUPPLY AIR BLOWER PERFORMANCE (20 TON)**BOTTOM DUCT CONNECTIONS**

BLOWER SPEED, (RPM)	MOTOR PULLEY (TURNS OPEN)*	CFM														
		6000			7000			8000			9000			9400		
		ESP	BHP	KW	ESP	BHP	KW	ESP	BHP	KW	ESP	BHP	KW	ESP	BHP	KW
208 VOLT AND STANDARD DRIVE																
870	6.0**	0.4	2.1	1.8	0.1	2.3	2.0	-	-	-	-	-	-	-	-	-
900	5.0	0.8	3.2	2.7	0.5	3.5	2.9	0.2	3.8	3.2	-	-	-	-	-	-
930	4.0	1.1	4.1	3.4	0.9	4.5	3.8	0.6	4.9	4.1	0.1	5.1	4.3	-	-	-
950	3.0	1.3	4.6	3.9	1.1	5.1	4.3	0.8	5.5	4.6	0.4	5.9	5.0	-	-	-
980	2.0	1.6	5.3	4.5	1.4	5.8	4.9	1.2	6.3	5.3	0.7	6.9	5.8	0.2	7.3	6.1
1015	1.0	1.9	5.9	5.0	1.7	6.5	5.5	1.5	7.0	5.9	1.0	7.7	6.5	0.6	8.2	6.9
208 VOLT AND HIGH SPEED DRIVE ACCESSORY																
950	6.0	1.3	4.6	3.9	1.1	5.1	4.3	0.8	5.5	4.6	0.4	5.9	5.0	-	-	-
980	5.0	1.6	5.3	4.5	1.4	5.8	4.9	1.2	6.3	5.3	0.7	6.9	5.8	0.2	7.3	6.1
1010	4.0	1.8	5.8	4.9	1.7	6.3	5.3	1.5	6.9	5.8	1.0	7.5	6.3	0.5	7.9	6.7
1020	3.5	1.9	6.1	5.1	1.8	6.5	5.5	1.6	7.1	6.0	1.1	7.8	6.6	0.6	8.3	7.0
1035	3.0	2.0	6.2	5.2	1.9	6.8	5.7	1.7	7.4	6.2	1.2	8.1	6.8	0.7	8.6	7.3
1050	2.5	2.1	6.4	5.4	2.0	7.0	5.9	1.8	7.6	6.4	1.3	8.3	7.0	-	-	-
1075	2.0	2.3	6.6	5.5	2.1	7.2	6.0	1.9	7.8	6.6	1.5	8.6	7.2	-	-	-
1100	1.0	2.4	6.7	5.6	2.2	7.3	6.1	2.1	7.9	6.7	-	-	-	-	-	-
230/460/575 VOLT AND STANDARD DRIVE																
870	6.0**	0.4	2.1	1.8	0.1	2.3	2.0	-	-	-	-	-	-	-	-	-
900	5.0	0.8	3.2	2.7	0.5	3.5	2.9	0.2	3.8	3.2	-	-	-	-	-	-
930	4.0	1.1	4.1	3.4	0.9	4.5	3.8	0.6	4.9	4.1	0.1	5.1	4.3	-	-	-
950	3.5	1.3	4.6	3.9	1.1	5.1	4.3	0.8	5.5	4.6	0.4	5.9	5.0	-	-	-
980	2.5	1.6	5.3	4.5	1.4	5.8	4.9	1.2	6.3	5.3	0.7	6.9	5.8	0.2	7.3	6.1
1015	1.5	1.9	5.9	5.0	1.7	6.5	5.5	1.5	7.0	5.9	1.0	7.7	6.5	0.6	8.2	6.9
1025	1.0	2.0	6.1	5.1	1.8	6.6	5.6	1.6	7.3	6.1	1.1	7.9	6.7	0.7	8.6	7.3
230/460/575 VOLT AND HIGH SPEED DRIVE ACCESSORY																
950	6.0	1.3	4.6	3.9	1.1	5.1	4.3	0.8	5.5	4.6	0.4	5.9	5.0	-	-	-
980	5.0	1.6	5.3	4.5	1.4	5.8	4.9	1.2	6.3	5.3	0.7	6.9	5.8	0.2	7.3	6.1
1015	4.0	1.9	5.9	5.0	1.7	6.5	5.5	1.5	7.0	5.9	1.0	7.7	6.5	0.6	8.2	6.9
1035	3.5	2.0	6.2	5.2	1.9	6.8	5.7	1.7	7.4	6.2	1.2	8.1	6.8	0.7	8.6	7.3
1050	3.0	2.1	6.4	5.4	2.0	7.0	5.9	1.8	7.6	6.4	1.3	8.3	7.0	-	-	-
1080	2.0	2.3	6.6	5.5	2.1	7.2	6.0	1.9	7.8	6.6	1.5	8.6	7.2	-	-	-
1100	1.5	2.4	6.7	5.6	2.2	7.3	6.1	2.1	7.9	6.7	-	-	-	-	-	-
1120	1.0	2.5	6.8	5.7	2.3	7.4	6.2	2.2	8.1	6.8	-	-	-	-	-	-

NOTES: 1. Blower performance includes fixed outdoor air, 2" T/A filters, a dry evaporator coil and no electric heat.

2. Refer to Page 12 for additional static resistances.

ESP = External Static Pressure available for the supply and return air duct system. All internal unit resistances have been deducted from the total static pressure of the blower.

* Do **NOT** close the pulley below 1 turn open.

** Factory setting.

TABLE 6 - STATIC RESISTANCES ¹

DESCRIPTION		EXTERNAL STATIC PRESSURE DROP					
		RESISTANCE, IWG					
		CFM					
		15 TON			20 TON		
		4500	6000	7200	6000	8000	9400
WET INDOOR COIL		0.1	0.1	0.1	0.1	0.1	0.1
ELECTRIC HEAT OPTIONS	18 KW	0.1	0.1	0.1	0.1	0.1	0.1
	36 KW	0.1	0.2	0.3	0.1	0.2	0.3
	54 KW	0.2	0.3	0.4	0.2	0.3	0.4
	72 KW	0.2	0.4	0.6	0.2	0.4	0.6
ECONOMIZER OPTION		0.1	0.1	0.1	0.1	0.1	0.1
HORIZONTAL DUCT CONNECTIONS ²		0.2	0.3	0.5	0.2	0.3	0.5

¹Deduct these resistance values from the available external static pressures shown in the respective Blower Performance Table. (See Note 2 for exception.)

²Since the resistance to air flow will be less for horizontal duct connections than for bottom duct connections, add these pressures to the ESP values on the respective unit's blower performance table.

TABLE 7 - POWER EXHAUST PERFORMANCE

MOTOR SPEED	STATIC RESISTANCE OF RETURN DUCTWORK, IWG									
	0.2		0.3		0.4		0.5		0.6	
	CFM	KW	CFM	KW	CFM	KW	CFM	KW	CFM	KW
HIGH*	5250	0.83	4500	0.85	4200	0.88	3750	0.93	3000	0.99
MEDIUM	4900	0.77	3900	0.79	3500	0.82	2900	0.85	-	-
LOW	4400	0.72	3700	0.74	3000	0.78	-	-	-	-

*Factory Setting

Power Exhaust motor is a 3/4 HP, PSC type with sleeve bearings, a 48 frame and inherent protection.

TABLE 8 - BLOWER MOTOR AND DRIVE DATA

MODEL SIZE	DRIVE	BLOWER RANGE (RPM)	MOTOR ¹			ADJUSTABLE MOTOR PULLEY				FIXED BLOWER PULLEY				BELT (NOTCHED)		
			HP	FRAME	EFF. (%)	DESIG-NATION	OUTSIDE DIA. (IN.)	PITCH DIA. (IN.)	BORE (IN.)	DESIG-NATION	OUTSIDE DIA. (IN.)	PITCH DIA. (IN.)	BORE (IN.)	DESIG-NATION	PITCH LENGTH (IN.)	QTY.
15 TON	Standard	850/1065	5	184T	83	1VP56	5.35	4.3-5.3 ²	1-1/8	BK90	8.75	8.4	1	BX70	71.8	1
	High Speed Access	965/1190								BK80	7.75	7.4	1	BX68	69.8	1
20 TON	Standard	870/1025	7.5	213T	89	1VP68	6.75	5.5-6.5 ²	1-3/8	BK120	11.75	11.4	1-3/16	BX83	84.8	1
	High Speed Access	950/1120								BK110	10.75	10.4	1-3/16	BX80	81.8	1

¹All motors have a nominal speed of 1800 RPM, a 1.15 service factor and a solid base. They can operate to the limit of their service factor because they are located in the moving air, upstream of any heating device.

²Do NOT close this pulley below 1 turn open.

TABLE 9 - ELECTRICAL DATA (BASIC UNITS)

MODEL	POWER SUPPLY	COMPRESSORS				COND. FAN MOTORS (#1 & #2)		SUPPLY AIR BLOWER MOTOR		MINIMUM CIRCUIT AMPACITY (AMPS)	MAXIMUM TIME DELAY FUSE SIZE (AMPS)	MINIMUM WIRE SIZE* (AWG)
		#1		#2		HP EACH	FLA EACH	HP	FLA			
		RLA	LRA	RLA	LRA							75°C
DEE180	208/230-3-60	33.4	300	16.7	150	1	4.2	5	14.4	77.0	90	4
	460-3-60	19.2	146	9.6	73	1	2.1	5	7.2	42.7	50	8
	575-3-60	12.8	124	6.4	62	1	2.0	5	5.9	30.7	35	8
DEE240	208/230-3-60	32.0	274	32.0	274	1	4.2	7.5	19.4	96.8	110	3
	460-3-60	18.0	138	18.0	138	1	2.1	7.5	9.7	52.2	60	6
	575-3-60	13.2	116	13.2	116	1	2.0	7.5	7.8	40.2	45	8

*Although these sizes are based on copper conductors, aluminum wire can be used. Refer to the National Electric Code to determine the proper size.

VOLTAGE LIMITATIONS**	POWER SUPPLY	VOLTAGE	
		MIN.	MAX.
	208/230-3-60	187	253
460-3-60	414	506	
575-3-60	518	630	

**Utilization Range "A" in accordance with ARI Standard 110.

TABLE 10 - ELECTRICAL DATA (UNITS w/SUPPLEMENTAL ELECTRIC HEAT)

MODEL D1EE	POWER SUPPLY	HEATER OPTION				MINIMUM CIRCUIT AMPACITY (AMPS)	MAXIMUM TIME DELAY FUSE SIZE (AMPS)	MINIMUM WIRE SIZE ² (AWG)
		MODEL	KW ¹	STAGES	AMPS			
180A25	208-3-60	E018	13.5	1	37.5	77.0	90	4
		E036	27.0	2	75.1	111.8	125	2
		E054	40.6	2	112.6	158.7	175	00
		E072	54.1	2	150.1	168.1	200	00
	230-3-60	E018	18.0	1	43.3	77.0	90	4
		E036	36.0	2	86.6	126.3	150	1
		E054	54.0	2	129.9	147.9	175	0
		E072	72.0	2	173.2	191.2	225	000
180A46	460-3-60	E018	18.0	1	21.7	42.7	50	8
		E036	36.0	2	43.3	63.1	70	6
		E054	54.0	2	65.0	74.0	90	4
		E072	72.0	2	86.6	95.6	110	3
180A58	575-3-60	E018	18.0	1	17.3	30.7	35	8
		E036	36.0	2	34.6	50.7	60	6
		E054	54.0	2	52.0	59.3	70	6
		E072	72.0	2	69.3	76.7	90	4
240A25	208-3-60	E018	13.5	1	37.5	96.8	110	3
		E036	27.0	2	75.1	118.1	125	1
		E054	40.6	2	112.6	165.0	175	00
		E072	54.1	2	150.1	174.4	200	00
	230-3-60	E018	18.0	1	43.3	96.8	110	3
		E036	36.0	2	86.6	132.5	150	0
		E054	54.0	2	129.9	154.2	175	00
		E072	72.0	2	173.2	197.5	225	000
240A46	460-3-60	E018	18.0	1	21.7	52.2	60	6
		E036	36.0	2	43.3	66.3	70	4
		E054	54.0	2	65.0	77.1	90	4
		E072	72.0	2	86.6	98.7	110	3
240A58	575-3-60	E018	18.0	1	17.3	40.2	45	8
		E036	36.0	2	34.6	53.1	60	6
		E054	54.0	2	52.0	61.7	70	6
		E072	72.0	2	69.3	79.0	90	4

¹Electric Heat CORRECTION FACTORS:

NOMINAL VOLTAGE	VOLTAGE	KW CAP. MULTIPLIER
208	208	1.00
240	230	0.92
480	460	0.92
600	575	0.92

²Although these sizes are based on copper conductors, aluminum wire can be used. Refer to the National Electric code (in U.S.A.) or the current Canadian Electrical Code (in Canada) to determine the proper size.

OPERATION

COOLING SYSTEM

The unit has an air-cooled cooling section and is factory-charged with Refrigerant-22.

The compressors are hermetically sealed, internally sprung and base-mounted with rubber-insulated hold-down bolts.

Compressors have inherent (internal) protection. If there is an abnormal temperature rise in a compressor, the protector will open to shut down the compressor.

PRELIMINARY OPERATION COOLING

After installation has been completed, energize the crankcase heaters for at least four hours before operating the unit. After the initial installation, the compressors should be given three false starts (energized just long enough to make a few revolutions) with 5-7 minutes delay between each start, before being put into full time service.

NOTE: Prior to each cooling season, the crankcase heaters must be energized at least 8 hours before system is put into operation.

COOLING SEQUENCE OF OPERATION

NO OUTDOOR AIR OPTIONS - When the room thermostat calls for "first-stage" cooling, the low voltage control circuit from "R" to "G" and "Y1" is completed to energize compressor #1, condenser fan motor #1, condenser fan motor #2 (if the ambient temperature is above 60°F), and the supply air blower motor (if the fan switch on the room thermostat is set in the "AUTO" position).

When the thermostat calls for "second-stage" cooling, the low voltage control circuit from "R" to "Y2" is completed to energize compressor #2.

After the thermostat is satisfied and opens, all components will stop simultaneously. The blower motor will continue to operate if the fan switch on the room thermostat is set in the "ON" position.

ECONOMIZER WITH SINGLE ENTHALPY SENSOR - When the room thermostat calls for "first-stage" cooling, the low voltage control circuit from "R" to "G" and "Y1" is completed. The "R" to "G" circuit energizes the blower motor (if the fan switch on the room thermostat is set in the "AUTO" position) and drives the economizer dampers from fully closed to their minimum position. If the enthalpy of the outdoor air is below the setpoint of the enthalpy controller (previously determined), "Y1" energizes the economizer. The dampers will modulate to maintain a constant supply air temperature as monitored by the discharge air sensor. If the outdoor air enthalpy is above the setpoint, "Y1" energizes compressor #1, condenser fan motor #1, and condenser fan motor #2 (if the ambient temperature is above 60°F).

When the thermostat calls for "second-stage" cooling, the low voltage control circuit from "R" to "Y2" is completed. If the enthalpy of the outdoor air is below the setpoint of the enthalpy controller (i.e. first stage has energized the economizer), "Y2" will energize compressor #1. If the outdoor air is above the setpoint, "Y2" will energize compressor #2.

After the thermostat is satisfied and opens, all components will stop simultaneously. The blower motor will continue to operate if the fan switch on the room thermostat is set in the "ON" position.

ECONOMIZER WITH DUAL ENTHALPY SENSORS - The operation with the dual enthalpy sensors is identical to the single sensor except that a second enthalpy sensor is mounted in the return air. This return air sensor allows the economizer to choose between outdoor air and return air, whichever has the lowest enthalpy value, to provide maximum operating efficiency.

ECONOMIZER (SINGLE OR DUAL) WITH POWER EXHAUST - This system operates as specified above with one addition. The power exhaust motor is energized whenever the economizer is chosen by the enthalpy sensor for first stage cooling, "Y1". As always, the "R" to "G" connection provides

minimum position but does not provide power exhaust operation.

MOTORIZED OUTDOOR AIR DAMPERS - This system operation is the same as the units with no outdoor air options with one exception. When the "R" to "G" circuit is complete, the motorized damper drives open to a position set by the thumbwheel on the damper motor. When the "R" to "G" circuit is opened, the damper spring returns fully closed.

SAFETY CONTROLS

Each refrigerant system is equipped with the following safety controls:

1. A **Suction Line Freezestat** to protect against low evaporator temperatures due to a low air flow or a low return air temperature. (Opens at 26EF ± 5EF and resets at 38EF ± 5EF)
2. A **High Pressure Cutout Switch** to protect against excessive discharge pressures due to a blocked condenser coil or a condenser motor failure. (Opens at 380 psig ± 10 and resets at 300 psig ± 10)
3. A **Low Pressure Switch/Loss Of Charge** to protect against loss of refrigerant charge. (Opens at 7 psig ± 3 and resets at 22 psig ± 5)

If either one of the above safety controls opens, that individual refrigerant system will be locked out. The other refrigerant system will continue in operation unless it too is effected by the same fault. The lock out of either system can be reset by opening the 24V circuit either at the room thermostat or at the unit disconnect.

HEATING SEQUENCE OF OPERATION

SEQUENCE OF OPERATION WITH ELECTRIC HEAT

WITH POWER TO UNIT AND THERMOSTAT IN THE HEATING MODE

Single-stage heating: (applies only to 18 KW heater, all other heaters MUST use a two-stage thermostat:)

- a) If the fan switch is in the "ON" position, the evaporator blower motor contactor (3M) will be energized through terminal G to provide continuous blower operation. If the fan switch is in the "AUTO" position, the blower will operate only when there is a call for heating by the thermostat.

NOTE: All 240 & 480V heaters are provided with manual reset backup protection limits. These will de-energize the heaters should the primary limit fail to open or the contactors fail to open in a failure mode.

- b) Upon a call for heat by the thermostat, the heater contactor (6M) will be energized.
- c) The thermostat will cycle the electric heat to satisfy the heating requirements of the conditioned space.

Two-stage heating: (applies to all heaters except 18 KW):

- a) If the fan switch is in the "ON" position, the evaporator blower motor contactor (3M) will be energized through terminal G to provide continuous blower operation. If the fan switch is in the "AUTO" position, the blower will operate only when there is a call for heating by the thermostat.
- b) Upon a call for first-stage heat by the thermostat, the heater contactor (6M) (6M & 7M on 72 KW, 240V) will be energized.

If the second stage of heat is required, heater contactor (7M) will be energized. Note that on the 54 KW, 240V heater, heater contactors (7M & 8M) will be energized and on the 72 KW, 240V heater, heater contactors (8M & 9M) will be energized.

- c) The thermostat will cycle the electric heat to satisfy the heating requirements of the conditioned space.

HEAT ANTICIPATOR SETPOINTS

It is important that the anticipator setpoint be correct. Too high of a setting will result in longer heat cycles and a greater temperature swing in the conditioned space. Reducing the value below the correct setpoint will give shorter "ON" cycles and may result in the lowering of the temperature within the conditioned space. Refer to Table 12 for the required heat anticipator setting.

CHECKING SUPPLY AIR CFM

TABLE 10 - HEAT ANTICIPATOR SETTING

HEATER KW	VOLTAGE	SETTING, AMPS	
		TH1	TH2
18	208/230-3-60	0.29	-
36		0.29	0.29
54		0.29	0.58
72		0.58	0.58
18	460-3-60	0.29	-
36		0.29	0.29
54		0.29	0.29
72		0.29	0.29
18	575-3-60	0.29	-
36		0.29	0.29
54		0.29	0.29
72		0.29	0.29

The RPM of the supply air blower will depend on the required CFM, the unit options/accessories and the static resistances of both the supply and the return air duct systems. With this information, the RPM for the supply air blower and the motor pulley adjustment (turns open) can be determined from the blower performance data in Tables 5 and 6.

High speed drive accessories (containing a smaller blower pulley and a shorter belt) are available for applications requiring the supply air blower to produce higher CFM's and/or higher static pressures. Use Model 1LD0416 for 15 ton units and Model 1LD0417 for 20 ton units. Refer to Table 9 for blower motor and drive data.

Note the following:

1. The supply air CFM must be within the limitations shown in Table 1.
2. Pulleys can be adjusted in half turn increments.
3. The tension on the belt should be adjusted as shown in Figure 10.

Start the supply air blower motor. Adjust the resistances in both the supply and the return air duct systems to balance the air distribution throughout the conditioned space. The job specifications may require that this balancing be done by someone other than the equipment installer.

To check the supply air CFM after the initial balancing has been completed:

1. Remove the two 5/16" dot plugs from the blower motor and the filter access panels shown in Figure 9.
2. Insert at least 8" of 1/4 inch tubing into each of these holes for sufficient penetration into the air flow on both sides of the indoor coil.

NOTE: The tubes must be inserted and held in a position perpendicular to the air flow so that velocity pressure will not affect the static pressure readings.

3. Using an inclined manometer, determine the pressure drop across a dry indoor coil. Since the moisture on an indoor coil may vary greatly, measuring the pressure drop across a wet coil under field conditions would be inaccurate. To assure a dry coil, the compressors should be de-activated while the test is being run.
4. Knowing the pressure drop across a dry coil, the actual CFM through the unit and clean 2" filters, can be determined from the curve in Figure 12.

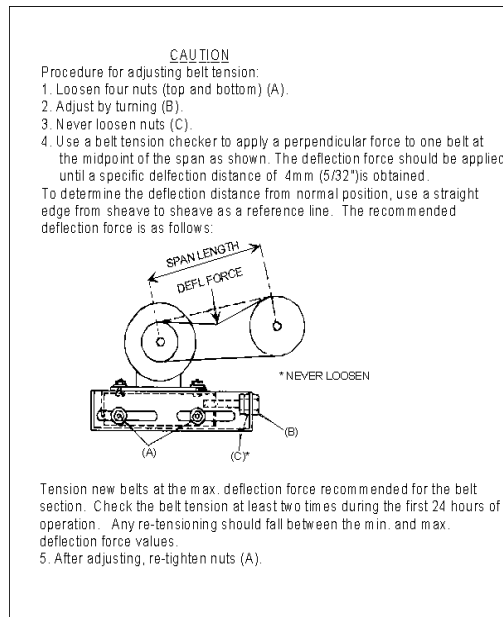

FIG. 8 - BELT ADJUSTMENT

WARNING: Failure to properly adjust the total system air quantity can result in extensive blower damage.

After readings have been obtained, remove the tubes and reinstall the two 5/16" dot plugs that were removed in Step 1.

NOTE: DE-ENERGIZE THE COMPRESSORS BEFORE TAKING ANY TEST MEASUREMENTS TO ASSURE A DRY INDOOR COIL.

BELT DRIVE BLOWER

All units have belt drive single-speed blower motors. The variable pitch pulley on the blower motor can be adjusted to obtain the desired supply air CFM. Tighten belts enough to prevent slipping, but do not overtighten. Belt deflection should be between 1/4" and 1/2" per foot.

NORMAL MAINTENANCE

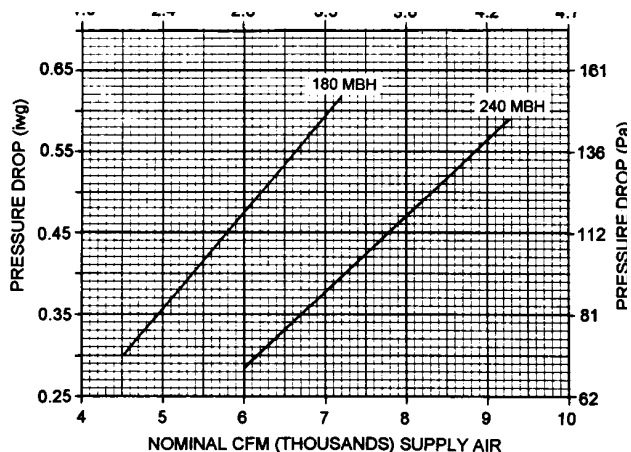

FIG. 9 - PRESSURE DROP ACROSS A DRY INDOOR COIL VS SUPPLY AIR CFM

SECURE OWNER'S APPROVAL: *When the system is functioning properly, secure the owner's approval. Show him the location of all disconnect switches and the thermostat. Teach him how to start and stop the unit and how to adjust temperature settings within the limitations of the system.*

MAINTENANCE

CAUTION: *Prior to any of the following maintenance procedures, shut off all electric power to the unit to prevent personal injury.*

FILTERS - Inspect once a month. Replace disposable or clean permanent type as necessary. **DO NOT** replace permanent type with disposable. The dimensional size of the replacement filter must be the same as the replaced filter.

MOTORS

Outdoor fan motors are permanently lubricated and require no maintenance.

Indoor Blower Motor and Drive - The indoor blower motor features ball bearings that do not require periodic lubrication. Periodic lubrication of the motor and bearings can extend the life of components but is optional.

CAUTION: *Damage can occur if the bearings are overlubricated. Use grease sparingly.*

WARNING: *Perform all maintenance operations on the blower motor with electric power disconnected from the unit. Do not attempt to lubricate bearings with the unit in operation.*

On an annual basis, check the motor for accumulations of dust, etc. that may block the cooling slots in the motor shell. Check for loose, damaged or misaligned drive components. Check that all mounting bolts are tight. Replace defective parts as required.

If desired, every three years remove both pipe plugs at each end shell and clean out any hardened grease or foreign matter. Replace one plug on each end with a clean grease fitting. Using a low pressure grease gun, pump grease (Chevron SRI-2 or equivalent) into the bearing cavity until new grease shows at the open port. Do not over lubricate. Run the motor for ten minutes until excess grease is purged from the cavity. Replace the plugs.

On 20 ton only, units are supplied with blower shaft bearings that do not require maintenance but may be relubricated if desired. Every three years, using a low pressure grease gun, pump grease into the bearing grease fitting until grease just begins to show at the seals. Do not over lubricate. Use any lithium base grease recommended for ball bearing service.

OUTDOOR COIL - Dirt should not be allowed to accumulate on the outdoor coil surface or other parts in the air circuit. Cleaning should be as often as necessary to keep coil clean. Use a brush, vacuum cleaner attachment, or other suitable means. If water is used to clean coil, be sure electric power to the unit is shut off prior to cleaning.

NOTE: *Exercise care when cleaning the coil so that the coil fins are not damaged.*

Do not permit the hot outdoor air discharge to be obstructed by overhanging structures or shrubs.



Heating and Air Conditioning