

UPBA450/450S 1/2"-2"



Bronze Ball Valve For Potable Water
Two Piece
Full Port
600 psig WOG
Solder Ends
Blow-Out Proof Stem

Dimensions and Workmanship Conform to MSS SP-110

MATERIALS LIST

ITEM	PART	MATERIALS	ASTM SPEC.
1	Body	Cast Bronze	B584 C89833
2	Tailpiece	Cast Bronze	B584 C89833
3	Ball	Brass w/Hard Chrome Plating	B283 C27450
		316 Stainless Steel (1)	A276 S31600
4	Seat	RPTFE, 15% Glass Filled	Commercial
5	Stem	Brass (2" only)	B21 C46400
		316 Stainless Steel (1)	A276 S31600
6	Thrust Washer	RPTFE, 25% Glass Filled	Commercial
7	Packing	PTFE	Commercial
8	Packing Nut	Brass	B16 C36000
9	Handle	Steel w/Zinc Plating	Commercial
10	Handle Grip	Vinyl	Commercial
11	Handle Nut	Steel w/Zinc Plating	Commercial

(1) Ball and stem are stainless for UPBA450S

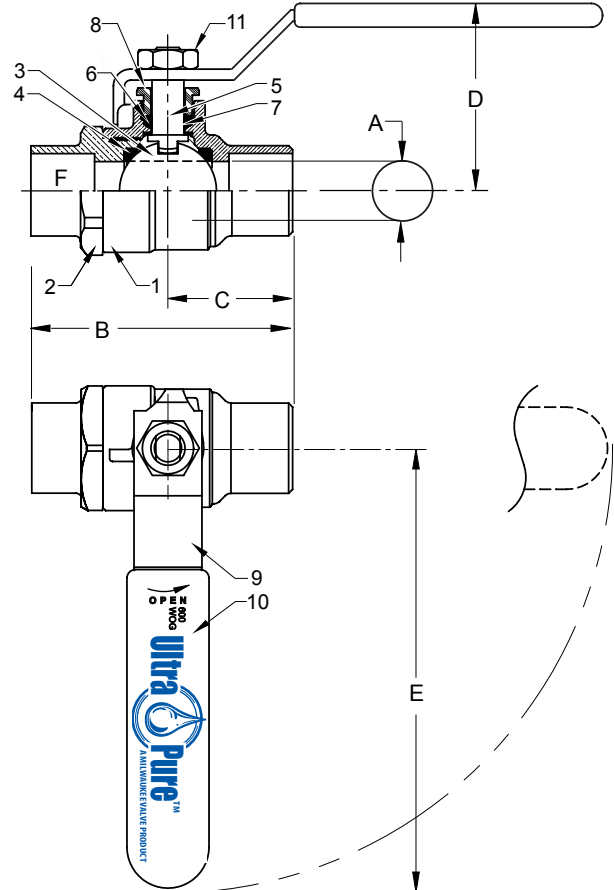

DIMENSIONS

	UNITS	1/2" DN15	3/4" DN20	1" DN25	1-1/4" DN32	1-1/2" DN40	2" DN50
A (DIA)	INCHES	0.50	0.76	1.06	1.31	1.56	2.00
	mm	13	19	27	32	40	51
B	INCHES	2.39	3.17	3.75	5.00	6.00	6.75
	mm	59	81	95	127	152	172
C	INCHES	1.07	1.50	1.79	2.49	3.00	3.37
	mm	27	38	46	63	76	86
D	INCHES	1.87	2.19	2.67	2.82	2.99	3.51
	mm	46	56	68	72	76	89
E	INCHES	3.80	4.56	6.31	6.31	6.31	7.19
	mm	97	116	160	160	160	183
F	TUBE SIZEØ	0.63	0.88	1.13	1.38	1.63	2.13
	Cv	15	35	60	110	185	360

Note: DN (Diameter Nominal) = Metric equivalent size.

Note: Lead free refers to the wetted surface of the pipe, fittings and fixtures in potable water systems that have a weighted average lead content $\leq 0.25\%$. Source: California Health and Safety Code (116875).

The information presented on this sheet is correct at the time of publication. Milwaukee Valve reserves the right to change design, and/or material specifications without notice. For the Installation, Operation and Maintenance Manual (IOM) see the Technical/Service Information section on our website. For the most current information access www.milwaukeevalve.com

