



# Multi Zone Specification

## AUU12RML Multizone Cassette

THE POSSIBILITIES ARE INFINITE

Job Name: \_\_\_\_\_  
 Location: \_\_\_\_\_  
 Engineer: \_\_\_\_\_  
 Submitted to: \_\_\_\_\_  
 Submitted by: \_\_\_\_\_

Approval: \_\_\_\_\_  
 Date: \_\_\_\_\_  
 Construction: \_\_\_\_\_  
 Unit #: \_\_\_\_\_  
 Drawing #: \_\_\_\_\_

**Power** V/Hz/P 230/60/1

**Fan type** Turbo  
 No. Motors (W) 42-1  
 CFM (Hi,Me,Lo,Qu) 359/312/277/241  
 Sound Pressure Level db (Hi,Me,Lo,Qu) 37/33/31/27  
 F.L.A. (A) .15

**Refrigerant** 410A  
 O.D. Discharge in (mm) 1/4" (6.35)  
 O.D. Suction in (mm) 3/8" (9.52)

**Dimensions** H x W x D  
 Unit Uncrated (in) 9-21/32 x 22-14/32 x 22-14/32  
 (mm) (245x570x570)  
 Unit Crated (in) 10-7/16 x 28-3/4 x 24-19/32  
 (mm) (265x730x625)  
 Panel Uncrated (in) 1-15/16 x 27-9/16 x 27-9/16  
 (mm) (49x700x700)  
 Panel Crated (in) 4-23/32 x 30-1/8 x 29-23/32  
 (mm) (120x765x755)

**Weight**  
 Unit Net lbs. (kg) 33 (15)  
 Unit Gross Shipping lbs. (kg) 40 (18)  
 Panel Net lbs. (kg) 5.7 (2.6)  
 Panel Gross Shipping lbs. (kg) 10 (4.5)

**Reference:** \_\_\_\_\_

**Cooling Capacity** (BTU/h) 12,000 (5,100-13,600)  
**Moisture Removal** pt/h (l/h) 2.5 (1.2)

**Heating Capacity** (BTU/h) 14,000 (5,100-15,400)

**Temperature Setting Range**  
 Cooling °F(°C) 64~90 (18~32)  
 Heating °F(°C) 60~80 (16~31)

**Drain Pipe Size** OD in (mm) Ø1 (25.4)  
 ID in (mm) Ø3/4 (19.4)

**Condensate Pum Lift\*** in (mm) 28 (700)

**Remote Control Type** Wired (Wireless Optional)

**Electrical Connection\*\*** AWG 14/3 with ground

\*Pump is capable of providing 28" of lift at no more than 6" away from the unit. Lift is measured from the suction of the pump which is located at the bottom of the unit and not the outlet of the condensate.

\*\*Power and communication are fed from the outdoor unit.

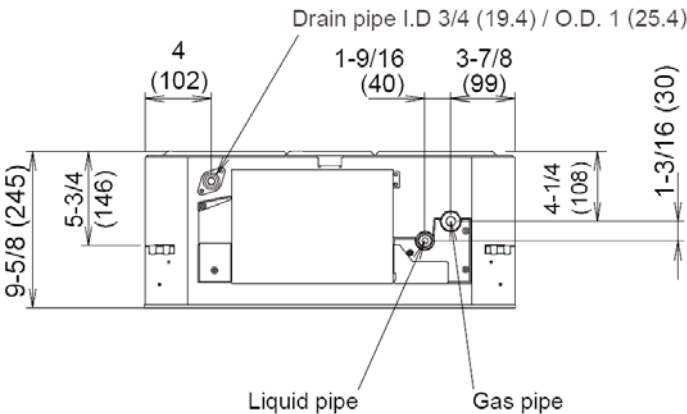
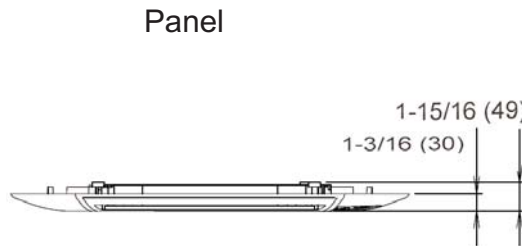
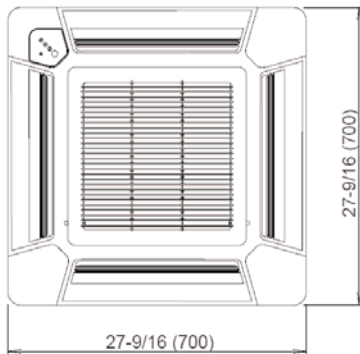

Unit

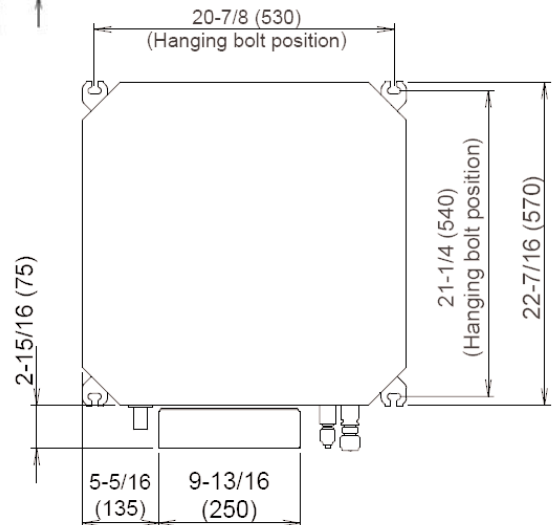

Fujitsu General America, Inc.  
 Fairfield, NJ 07004  
 Toll Free: 1-888-888-3424  
 Fax: (973) 836-0447  
 www.fujitsugeneral.com

Note:  
 Specifications are based on the following conditions.  
 Power source of specifications : 230V  
 Cooling: Indoor temperature of 80°F(26.67°C)DB / 67°F(19.44°C)WB, and outdoor temperature of 95°F(35°C)DB/75°F(23.89°C)WB.  
 Heating: Indoor temperature of 70°F(21.11°C)DB / 60°F(15.56°C)WB, and outdoor temperature of 47°F(8.33°C)DB/43°F(6.11°C)WB.  
 Pipe length : 24ft. 7in.(7.5m),Height difference : 0 ft.(0m) [Outdoor unit - Indoor unit]  
 Fujitsu products are subject to continuous improvements. Fujitsu reserves the right to modify product design, specifications and information in this data sheet without notice and without incurring any obligations.