

# TECHNICAL GUIDE

**R-410A  
ZV SERIES  
3 - 5 TON  
60 Hertz**



ZT 3 THROUGH 5 TON

## Description

### ASHRAE 90.1 COMPLIANT

Unitary Products ZV units are convertible single packages with a common footprint cabinet and common roof curb for all 3 through 5 ton models. The units were designed for light commercial applications and can be easily installed on a roof curb, slab, or frame.

All ZV units are self-contained and assembled on rigid full perimeter base rails allowing for 3-way forklift access and overhead rigging. Every unit is completely charged, wired, piped, and tested at the factory to provide a quick and easy field installation.

ZV units in all tonnage sizes are convertible between side airflow and down airflow, with corresponding economizer if economizer option is desired.

ZV units are available in the following configurations: cooling only, cooling with electric heat and cooling with gas heat. Electric heaters are available as factory-installed options or field-installed accessories.

All units meet ASHRAE 90.1 single-zone variable supply air volume standard. Featuring a variable frequency drive on 3 through 5 ton ZV models.

Tested in accordance with:



## Table of Contents

Description .....	1
Table of Contents .....	2
Component Location .....	2
Nomenclature .....	3
Features and Benefits .....	4
Guide Specifications .....	10
Physical Data .....	13
Capacity Performance .....	18
Airflow Performance .....	34
Sound Performance .....	36
Electrical Data .....	48
Typical Wiring Diagrams .....	53
Weights and Dimensions .....	65
Economizer Options .....	72

## Component Location

### Cooling With Gas Heat (3 Through 5 Ton)

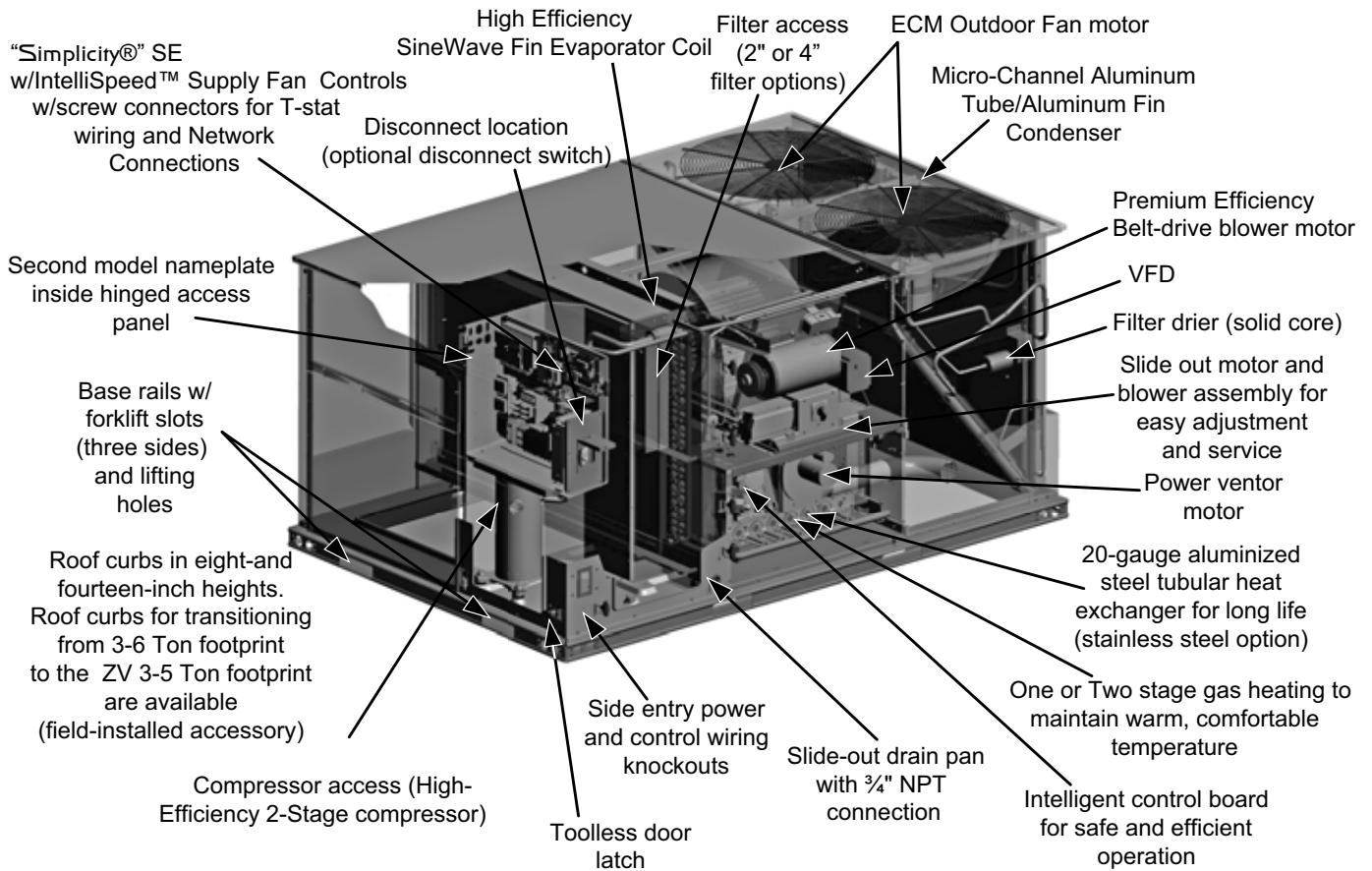

# Nomenclature

## 3-5 Ton Model Number Nomenclature

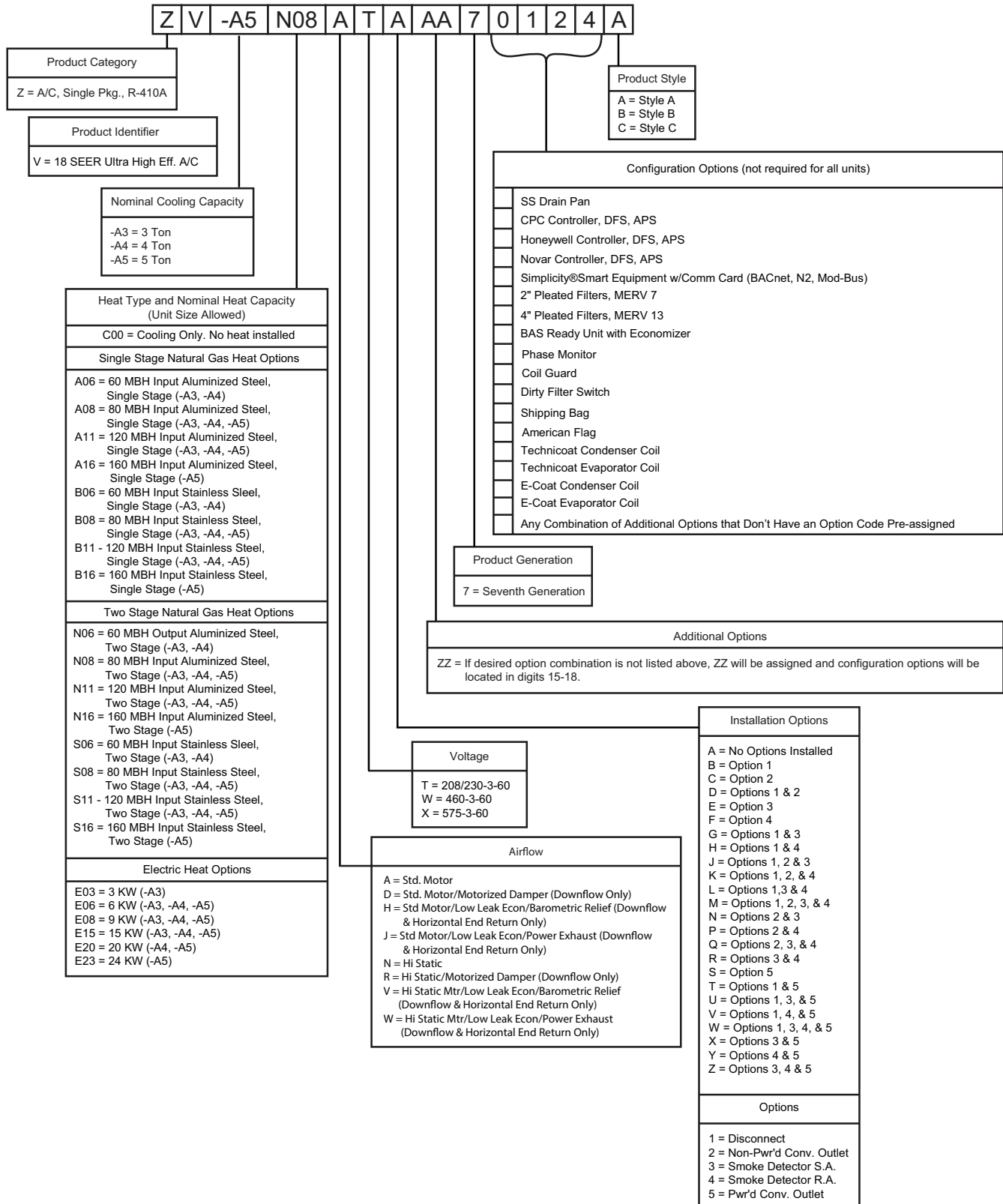

## Features and Benefits

### Standard Features for Ultra High Efficiency 3-5 Ton Units

- **Efficiency** – High efficiency units reach as high as 18.1 SEER and 14.35 EER. Gas/electric units have electronic spark ignition and power vented combustion with steady state efficiencies of 80%. These efficiencies exceed all legislated minimum levels and provide low operating costs.
- **Service Friendly** - The ZV Unit incorporates a number of key features for ease of serviceability.

The motor and blower slide out of the unit as a common assembly. This facilitates greater access to all the indoor airflow components, thus simplifying maintenance and adjustment.

Service time is reduced through the use of hinged, toolless panels. Such panels provide access to frequently inspected components and areas, including the control box, compressors, filters, indoor motor & blower, and the heating section. The panels are screwed in place at the factory to prevent access by children or other unauthorized persons. It is recommended that the panels be secured with screws once service is complete.

Service windows have been placed in both condenser section walls. Rotation of the cover allows easy access to the condenser coils for cleaning or inspection.

The Simplicity® SE control board provides alarm messages to help quickly identify any faults.

All units use four filters of the same standard size. This standardization simplifies selections for filter replacement.

The non-corrosive drain pan slides out of the unit to permit easy cleaning. The drain pan is accessed by removing the drain pan cover plate on the rear of the unit. Once the plate is removed, the drain pan slides out through the rear of the unit.

All ZV units have a second model nameplate located inside the control access door. This is to prevent deterioration of the nameplate through weathering.

- **Indoor Motors** - Units come from the factory with Premium Efficiency, Inverter rated, Indoor Motor. Both motor and belt drive blower are mounted on a slide out assembly for ease of service.
- **VFD** - These factory supplied Variable Frequency Drives come with a 5 year warranty from the manufacturer. They also provide ease of commissioning without the need of a computer to program the motor. That also provide a soft start which equates to longevity of motor and belt life.
- **Outdoor motors** - Units come from the factory with long lasting, high efficiency ECM motors.
- **Coil Technology** – All ZT condensers utilize Micro-Channel “all-aluminum” condensers which provide improved heat transfer capabilities and reduced charge volumes. All evaporators utilize a conventional copper tube/aluminum fin design for proven reliability and performance.
- **Environmentally Aware** - For improved Indoor Air Quality, a combination of aluminum foil faced and elastometric rubber insulations are used exclusively throughout the units.

- **Balanced Heating** – The ZV two stage gas heating offers “Ultimate Heating Comfort” with a balance between 1<sup>st</sup> and 2<sup>nd</sup> stage gas heating. The first stage of a gas heat ZV unit provides 70% or 75% of the heating capacity.
- **Convertible Airflow Design** – The side duct openings are covered when they leave the factory. If a side supply/return is desired, the installer simply removes the two side duct covers from the outside of the unit and installs them over the down shot openings. No panel cutting is required. Convertible airflow design allows maximum field flexibility and minimum inventory.
- **Advanced Controls** - Simplicity® SE control boards have standardized a number of features previously available only as options or by utilizing additional controls.

### CAUTION

The Simplicity® SE control board used in this product will effectively operate the cooling system down to 0°F when this product is applied in a comfort cooling application for people. An economizer is typically included in this type of application. When applying this product for process cooling applications (computer rooms, switchgear, etc.), please reference applications bulletin AE-011-07 or call the applications department for Unitary Products @ 1-877-UPG-SERV for guidance. Additional accessories may be needed for stable operation at temperatures below 30°F.

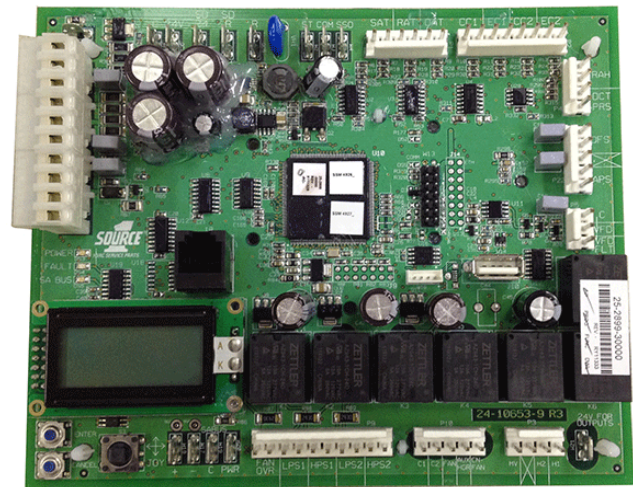

- **Units will come with the new state of the art Simplicity SE (Smart Equipment) control system.** The new unit control incorporates the best of the already proven Simplicity™ unitary controls and creates a more robust, intelligent control. The goal of this control is to utilize cutting edge technology making the equipment easier to install, operate, and service. All units are Factory commissioned, configured, and run tested.
- **Versatile** - The Simplicity SE control can be configured to use with a standard thermostat (easy to connect screw



terminals), A zone sensor, or can be setup to communicate with multiple BAS communication protocols to integrate with building automation systems.

- **Reduce field installed complexity** - Each unit will come equipped with factory installed supply air, return air, and outdoor air temperature sensors providing key temperature readings thus reduce field installed complexity.
- **On-board USB Port** - The new control comes with a long list of features including data logging, current and previous system faults and software update capabilities using the on board USB port and common flash drive. Energy use monitoring capabilities allow custom tailoring to allow a system to work more efficiently at all times and occupancy levels. Self test and start-up reports also available from the board VIA the USB port.
- **Embedded LCD Display** - The board has a easy to read, built-in LCD display and easy to use navigation joystick and buttons allowing the user to quickly navigate the menus displaying unit status, options, current function, supply, return and outdoor temperatures, fault codes and other information.
- **Safety Monitoring** - The control monitors the outdoor, supply, and return air temperatures and the high and low pressure switch status on the independent refrigerant circuits. On units with heating the gas valve and high temperature limit switches are monitored on gas and electric heating units. The control also monitors the voltage supplied to the unit and will protect the unit if low voltage due to a brown out, or other electrical issue occurs.
- **Low Ambient** - An integrated low-ambient control allows units to operate in the cooling mode down to 0°F outdoor ambient without additional components or intervention. Optionally, the control board can be programmed to lockout the compressors when the outdoor air temperature is low or when free cooling is available.
- **Anti-Short Cycle Protection** - To aid compressor life, an anti-short cycle delay is incorporated into the standard control. Compressor reliability is further ensured by programmable minimum run times. For testing, the anti-short cycle delay can be temporarily overridden with the push of a button.
- **Fan Delays** - Fan on and fan off delays are fully programmable. Furthermore, the heating and cooling fan delay times are independent of one another. All units are programmed with default values based upon their configuration of cooling and/or heating capacity.
- **Nuisance Trip Protection and Three Strikes** - To prevent nuisance calls, the control board uses a three times, you're out philosophy. The high, low-pressure switch, anti-freeze protection, low voltage or heating high limit must trip three times within two hours before the unit control board will lock out the associated compressor. An alarm message will be displayed on the LCD screen.
- **Lead-Lag** - An integrated Lead-Lag option allows equal run time hours on all compressors, thereby extending the life of all compressors. This option is selectable on the unit control board.
- **Low Limit Control (LLC)** - To prevent the supply air from dropping below a specified set point, when there is a demand for cooling during cold outside conditions. (Programmable Set point)
- **Reliable** - From the beginning - All units undergo computer automated testing before they leave the factory. Units are tested for refrigerant charge and pressure, unit amperage, and 100% functionality. For the long term - All units are painted with a long lasting, powder paint that stands up over the life of the unit. The paint used has been proven by a 1000 hour salt spray test.
- **Full Perimeter Base Rails** - The permanently attached base rails provide a solid foundation for the entire unit and protect the unit during shipment. The rails offer rigging holes so that an overhead crane can be used to place the units on a roof.
- **Easy Installation** - Gas and electric utility knockouts are supplied in the unit underside as well as the side of the unit. Utility connections can be made quickly and with a minimum amount of field labor. All units are shipped with 2" throw-away filters installed.
- **Wide Range of Indoor Airflows** - All supply air blowers are equipped with a belt drive that can be adjusted to meet the exact requirements of the job. A high static drive option is available for applications with a higher CFM and/or static pressure requirement.
- **Warranty** - All models include a 1-year limited warranty on the complete unit. Compressors and electric heater elements each carry a 5-year warranty. Aluminized steel (10 yr.) and stainless steel tubular heat exchangers carry a 15- year warranty.

### Factory Installed Options

Unitary Products offers several equipment options factory installed, for the ZV line.

- **Optional Factory Installed Economizers** - ZV units offer a variety of optional factory installed economizers with low leak dampers. The outdoor air dry bulb sensor enables economizer operation if the outdoor air temperature is less than the set point of the economizer logic module. See economizer options section to determine the correct economizer for your application.
- **Down flow / End Return Economizers (with barometric relief and fresh air hood)** - All units offer a variety of optional factory installed down flow economizers that are shipped, installed and wired with low leak dampers designed to meet ASHRAE 90.1-2010, AMCA 511 Class 1A damper, and the International Energy Conservation Code (IECC) certification requirements by achieving leakage rates of 3 cfm/sq. ft. at 1" of static pressure. Each economizer goes through a rigorous 60,000 cycle test. Dry bulb, single enthalpy, and dual enthalpy (with field installed kit) can be selected. The economizer has spring return, fully modulating damper actuators and is capable of introducing up to 100% outdoor air. As the outdoor air intake dampers open, the return air dampers close. The changeover from mechanical refrigeration to economizer operation is regulated by the outdoor air dry bulb temperature or the outdoor air enthalpy input. The optional (field installed) single or dual enthalpy kits provide

additional inputs to monitor outdoor air/ or return air humidity and temperature for true enthalpy control. The installer needs only to assemble the outdoor air hood, attach the enthalpy control the hood and mount the hood to the unit (Hood and control are provided).

- **Power Exhaust** - This factory option allows down flow or horizontal end return economizer operation. **The power exhaust must be removed from the unit and mounted in the horizontal end return duct work when applying the product in the horizontal, end return configuration.**
- **Motorized Outdoor Air Damper** - The motorized outdoor air damper includes a slide-in/plug-in damper assembly with an outdoor air hood and filters. The outdoor air dampers open to the preset position when the indoor fan motor is energized. The damper has a range of 0% to 100% outdoor air entry.
- **Alternate Indoor Blower Motor** - For applications with high static restrictions, units are offered with optional indoor motors that provide higher static output and/or higher airflow, depending upon the installer's needs.
- **Aluminized Steel Gas Heat Exchanger** - For applications in non-corrosive environments.
- **Stainless Steel Gas Heat Exchanger** - For applications in corrosive environments, this option provides a full stainless steel heat exchanger assembly.
- **Stainless Steel Drain Pan** - An optional rust-proof stainless steel drain pan is available to provide years of trouble-free operation in corrosive environments.
- **Electric Heaters** - The electric heaters range from 3kW to 24kW and are available in all the voltage options of the base units. All heaters are intended for single point power supply.
- **Disconnect Switch** - For gas heat units and cooling units with electric heat, a HACR breaker sized to the unit is provided. For cooling only units, a switch sized to the largest electric heat available for the particular unit is provided. Factory installed option only.
- **Convenience Outlet - (Non-Powered/Powered)** - This option locates a 120V single-phase GFCI outlet with cover, on the corner of the unit housing adjacent to the compressors. The "Non-powered" option requires the installer to provide the 120V single-phase power source and wiring. The "Powered" option is powered by a stepdown transformer in the unit. Factory installed option only.
- **Smoke Detectors** - The smoke detectors stop operation of the unit and provide a fault message to the control board. Smoke detectors are available for both the supply and/or return air configurations.
- **Filters** - 2" Pleated MERV 7 or 4" Pleated MERV 13 are available to meet LEED requirements. A 2" Throwaway is shipped as standard.

## WARNING

Factory-installed smoke detectors may be subjected to extreme temperatures during "off" times due to outside air infiltration. These smoke detectors have an operational limit of -4°F to 158°F. Smoke detectors installed in areas that could be outside this range will have to be relocated to prevent false alarms.

- **Phase Monitors** - Designed to prevent unit damage. The phase monitor will shut the unit down in an out-of phase condition. **(Standard on units with Scroll Compressors.)**
- **Coil Guard** - Customers can purchase a coil guard kit to protect the condenser coil from damage. Additionally, this kit stops animals and foreign objects from entering the space between the inner condenser coil and the main cabinet. This is not a hail guard kit.
- **Dirty Filter Switch** - This kit includes a differential pressure switch that energizes the fault light on the unit thermostat, indicating that there is an abnormally high pressure drop across the filters. Factory installed option or field installed accessory.
- **Technicoat Condenser Coils** - The condenser coils are coated with a phenolic coating for protection against corrosion due to harsh environments.
- **Technicoat Evaporator Coil** - The evaporator coils are coated with a phenolic coating for protection against corrosion due to harsh environments.
- **E-coat Condenser Coils** - The condenser coils are coated with an epoxy polymer coating to protect against corrosion.
- **E-coat Evaporator Coils** - The evaporator coils are coated with an epoxy polymer coating to protect against corrosion.

## Control Options

- **Simplicity® SE with Communication Option Control** - The Unitary Products Simplicity® SE with Communication Option Control is factory installed. It includes all the features of the Simplicity® SE control with an additional gateway to BACnet MS/TP (programmable to Modbus or N2 protocols).
- **Novar® BAS Control** - The Novar® building automation system controller is factory installed. Includes supply air sensor, return air sensor, dirty filter indicator switch, and air proving switch.
- **CPC BAS Control** - The Computer Process Controls Model 810-3060 ARTC Advanced Rooftop building automation system controller is factory installed. Includes supply air sensor, return air sensor, with optional dirty filter indicator switch and air proving switch.
- **Honeywell BAS Control** - The Honeywell W7750C building automation system controller is factory installed. Includes air supply sensor, return air sensor, with optional dirty filter indicator switch, and air proving switch.

## Field Installed Accessories

Unitary Products offers several equipment accessories for field installation, for the ZV line.

- **Down flow and End Return Economizers (with fresh air hood and barometric relief)** - All units offer a variety of optional factory installed down flow economizers that are shipped, installed and wired with low leak dampers designed to meet ASHRAE 90.1-2010, AMCA 511 Class 1A damper, and the International Energy Conservation Code (IECC) certification requirements by achieving leakage rates of 3 cfm/sq. ft. at 1" of static pressure. Each economizer goes through a rigorous 60,000 cycle test. Dry bulb, single enthalpy, and dual enthalpy (with field installed kit) can be selected. The economizer has spring return, fully modulating damper actuators and is capable of introducing up to 100% outdoor air. As the outdoor air intake dampers open, the return air dampers close. The changeover from mechanical refrigeration to economizer operation is regulated by the outdoor air dry bulb temperature or the outdoor air enthalpy input. The dual enthalpy kit provides a second input used to monitor the return air (field installed). The installer needs only to assemble the outdoor air hood, attach the enthalpy control the hood and mount the hood to the unit (Hood and control are provided).
- **Single or Dual Enthalpy Control, Accessories** - These kits contain the required components to convert a dry bulb economizer to a single enthalpy and/or dual enthalpy economizer.
- **Barometric Relief Damper** - Zero to 100% capacity barometric relief dampers for use with horizontal flow, or field installed economizers.
- **Power Exhaust** - This accessory installs in the unit with a down flow or horizontal end return economizer. Power exhaust plugs into the connector in the unit bulkhead. **User must purchase the 1EH0408 barometric relief and hood kit when applying the product in a horizontal flow application. The power exhaust must be mounted in the horizontal end return ductwork.**
- **Manual Outdoor Air Damper** - Like the motorized outdoor air damper, each manual outdoor air damper includes a slide-in damper assembly with an outdoor air hood and filters. Customers have a choice of dampers with ranges of 0% to 100% or 0% to 35% outdoor air entry.
- **Motorized Outdoor Air Damper** - The motorized outdoor air damper includes a slide-in/plug-in damper assembly with an outdoor air hood and filters. The outdoor air dampers open to the preset position when the indoor fan motor is energized. The damper has a range of 0% to 100% outdoor air entry. Factory installed option or field installed accessory.
- **Smoke Detectors** - The smoke detectors stop operation of the unit by interrupting power to the control board if smoke is detected within the air compartment.
- **CO<sub>2</sub> Sensor** - Senses CO<sub>2</sub> levels and automatically overrides the economizer when levels rise above the preset limits.
- **Dirty Filter Switch** - This kit includes a differential pressure switch that energizes the fault light on the unit thermostat, indicating that there is an abnormally high pressure drop across the filters.
- **Coil Guard** - Field installed decorative wire coil guard.
- **Hail Guard** - This kit includes a sloped hood which installs over the outside condenser coil and prevents damage to the coil fins from hail strikes. Field installed accessory only.
- **Flue Exhaust Extension Kit** - In locations with wind or weather conditions which may interfere with proper exhausting of furnace combustion products, this kit can be installed to prevent the flue exhaust from entering nearby fresh air intakes.
- **-60°F Gas Heat Kit** - For installations which require gas heat units to perform in low ambient temperatures, a gas section heating kit is available. This kit provides electric heat in the gas heat controls section to ensure the gas valve and controls will continue to function properly at extremely low temperatures.
- **Gas Heat High Altitude Kit** - This kit converts a gas heat unit to operate at high altitudes, 2,000 to 6,000 feet. Conversion kits are available for natural gas and propane.
- **Gas Heat Propane Conversion Kit** - This kit converts a gas-fired heater from natural gas to propane. It contains the main burner orifices and gas valve replacement springs.
- **Gas Piping Kit** - Contains pipe nipples, fittings and gas cock required for gas supply connection with external shut off.
- **Electric Heaters** - The electric heaters range from 3kW to 24kW and are available in all the voltage options of the base units.  
All heaters are dual staged. Cooling units include an adapter panel for easy installation of the electric heaters. Necessary hardware and connectors are included with the heaters. All heaters are intended for single point power supply.
- **Metal Frame Filter Kit** - Metal frame with polyester filter medium.
- **Permanent Filters** - Permanent filters are available.
- **Roof Curbs** - Single Piece Adapter (10" High) - Roof curbs for transitioning from 7.5 T thru 12.5T DHB/ DUC/DHC/DUS to ZU/ZW/ZK 3- 12T units to Unitary Products units. Fits 3 to 5 Ton roof curbs only.
- **Roof Curb Transition** - Single Piece Adapter (10" High) - Roof curbs for transitioning from Sunline™ units to ZV units. Fits 3 to 5 Sunline™ roof curbs only.
- **Burglar Bars** - Mount in the supply and return openings to prevent entry into the duct work.
- **Thermostat** - The units are designed to operate with 24-volt electronic and electro-mechanical thermostats. All Ultra High Efficiency 3-5 Ton units (with or without an economizer) operate with two-stage heat/two-stage cool or two-stage cooling only thermostats, depending upon unit configuration.

**Accessories****Field Installed Accessories - Non-Electrical**

MODEL	VOLTAGE	DESCRIPTION	WHERE USED
1BD0408	All	Burglar Bars, Downflow	All Cabinets
1CG0427	All	Coil Guard	(Electric / Electric Models), 42" Tall Cabinets
1CG0428	All	Coil Guard	(Gas / Electric Models), 42" Tall Cabinets
1HG0415	All	Hail Guard Kit	All Short (42") Standard Cabinets
1FE0412	All	Flue Exhaust Extension Kit	All Cabinets
1FF0415	All	2" only Metal Filter Frame Kit	All Tall 42" Cabinets
1FL0423	All	Permanent 2" only Filter Kit (Includes (4) four Filters)	All Tall 42" Cabinets
1GP0405	All	Gas Piping Kit	All Cabinets
1HA0450	All	High Altitude Kit for Natural Gas	3 - 5T (80, 120 & 160 MBH Input)
1HA0451	All	High Altitude Kit for Natural Gas	3 - 4T (60 MBH Input)
1HA0452	All	High Altitude Kit for Propane	3 - 5T (80, 120 & 160 MBH Input)
1HA0453	All	High Altitude Kit for Propane	3 - 4T (60 MBH Input)
1NP0454	All	Propane Conversion Kit	3 - 5T (80, 120 & 160 MBH Input)
1NP0455	All	Propane Conversion Kit	3 - 4T (60 MBH Input)
1RC0470	All	Roof Curb, 8" Height	All Cabinets
1RC0471	All	Roof Curb, 14" Height	All Cabinets
1RC0472	All	Roof Curb, Transition (7.5 T thru 12.5T DHB/DUC/DHC/DUS to ZU/ZW/ZK 3- 12T)	All Cabinets
1WC0412	All	Wooden Crate for extra protection during shipping and handling	Standard Cabinets Only (not applicable to units 119" in length)
1LN0407	All	Low NOx Kit	3 - 5T (80, 120 & 160 MBH Input)
1LN0408	All	Low NOx Kit	3 - 5T (60 MBH Input)



**Accessories (Continued)****Field Installed Accessories - Electric Heat**

MODEL	VOLTAGE	DESCRIPTION	WHERE USED
2TP04510325	230	3kW Electric Heat	All 42" Cabinet 3 Ton Models
2TP04510346	460		
2TP04510625	230	6kW Electric Heat	All 42" Cabinet 3, 4 and 5 Ton Models
2TP04510646	460		
2TP04510825	230	9kW Electric Heat	All 42" Cabinet 3, 4 and 5 Ton Models
2TP04510846	460		
2TP04510858	575		
2TP04511525	230	15kW Electric Heat	All 42" Cabinet 3, 4 and 5 Ton Models
2TP04511546	460		
2TP04511558	575		
2TP04512025	230	20kW Electric Heat	All 42" 4 and 5 Ton Models
2TP04512046	460		
2TP04512058	575		
2TP04512325	230	24kW Electric Heat	All 42" Cabinet 5 Ton Models
2TP04512346	460		
2TP04512358	575		

**Field Installed Accessories - Fresh Air**

MODEL	VOLTAGE	DESCRIPTION	WHERE USED
1FA0413	All	Manual Outside Air Damper 0-35%, Downflow	All Cabinets
1FA0414	All	Manual Outside Air Damper 0-100%, Downflow	All Cabinets
1EH0408	All	Barometric Relief Kit for Power Exhaust, Horizontal Application	All Cabinets
2EC0401	All	Single Enthalpy Control	All Cabinets
2EC0402	All	Dual Enthalpy Control (Includes 2 Sensors)	All Cabinets
2EE04707424	All	Economizer for Downflow, End Return Horizontal, or ERV Applications. Includes FA Hood, Exhaust Hood w/ Baro Relief	All 42" Cabinets
2EE04706924	All	Horizontal Economizer without Barometric Relief	All Cabinets
2MD04703824	All	Motorized Damper, Downflow without Barometric Relief	All Cabinets
2MD04703924	All	Motorized Damper, Horizontal without Barometric Relief	All Cabinets
2PE04704706	230	Power Exhaust 230V Downflow or Horizontal	All Cabinets
2PE04704746	460	Power Exhaust 460V Downflow or Horizontal	All Cabinets
2PE04704758	575	Power Exhaust 575V Downflow or Horizontal	All Cabinets

**Field Installed Accessories - Controls**

MODEL	VOLTAGE	DESCRIPTION	WHERE USED
2AP0401	All	Air Proving Switch	All Units
2AQ04700324B	All	CO <sup>2</sup> Space Accessory	All Units
2AQ04700424C	All	CO <sup>2</sup> Unit Accessory	All Units
2DF0402	All	Dirty Air Switch	All Units
2SH0401	All	Wall Mounted humidity sensor-For use with MagnaDry Reheat or space humidity input to Simplicity SE board.	All Cabinets
2SD04700824	All	Smoke Detector for Supply	All Gen 6 and greater units with 2" & 4" Filters
2SD04700924	All	Smoke Detector for Return	All Gen 6 and greater units with 2" & 4" Filters
2SD04701024	All	Smoke Detector for Supply and Return	All Gen 6 and greater units with 2" & 4" Filters
S1-YK-MAP1810-0P	All	MAP (Mobile Access Portal) Gateway- For use with Simplicity SE Control.	All Units
S1-MP-PRTKIT-0P	All	MAP (Mobile Access Portal) Gateway Kit- Replacement MAP gateway protective case, lanyard and communication cable. Use only to replace worn or damaged components.	All Units

**Field Installed Accessories - Electrical**

MODEL	VOLTAGE	DESCRIPTION	WHERE USED
2BC04700106	230	Gas heat kit, -60°F	All Units
2BC04700151	460	Gas heat kit, -60°F	All Units
2BC04700154	575	Gas heat kit, -60°F	All Units

## Guide Specifications

### GENERAL

Units shall be manufactured by Unitary Products in an ISO 9001 certified facility. Unitary Products units are convertible single packages with a common footprint cabinet and common roof curb for all 3 through 5 ton models. The units were designed for light commercial applications and can be easily installed on a roof curb, slab, or frame. All Unitary Products units are self-contained and assembled on rigid full perimeter base rails allowing for 3-way forklift access and overhead rigging. Every unit is completely charged with R-410A, wired, piped, and tested at the factory to provide a quick and easy field installation. All units are convertible between side and down airflow. Independent economizer designs are used on side and down discharge applications, as well as all tonnage sizes. Unitary Products units are available in the following configurations: cooling only, cooling with electric heat and cooling with gas heat. Electric heaters are available as factory-installed options or field-installed accessories.

### DESCRIPTION

Units shall be factory assembled, single package, (Elec/Elec, Gas/Elec), designed for outdoor installation. They shall have built in field convertible duct connections for down discharge supply/return or horizontal discharge supply/return and be available with factory installed options or field installed accessories. The units shall be factory wired, piped and charged with R-410A refrigerant and factory tested prior to shipment. All unit wiring shall be both numbered and color coded. The cooling performance shall be rated in accordance with DOE and AHRI test procedures. Units shall be CSA certified to ANSI Z21.47 and UL 1995/CAN/CSA No. 236-M90 standards.

### UNIT CABINET

Unit cabinet shall be constructed of galvanized steel with exterior surfaces coated with a non-chalking, powder paint finish, certified at 1000 hour salt spray test per ASTM-B117 standards. Indoor blower sections shall be insulated with up to 1" thick insulation coated on the airside. Either aluminum foil faced or elastometric rubber insulation shall be used in the unit's compartments and be fastened to prevent insulation from entering the air stream. Cabinet doors shall be hinged with toolless access for easy servicing and maintenance. Full perimeter base rails shall be provided to assure reliable transit of equipment, overhead rigging, fork truck access and proper sealing on roof curb applications. Disposable 2" filters shall be furnished as standard and be accessible through hinged access door. Fan performance measuring ports shall be provided on the outside of the cabinet to allow accurate air measurements of evaporator fan performance without removing panels or creating bypass of the coils. Condensate pan shall be slide out design, constructed of a non corrosive material, internally sloped and conforming to ASHRAE 62-B9 standards. Condensate connection shall be a minimum of ¾" I.D. female and be rigid mount connection.

### INDOOR (EVAPORATOR) FAN ASSEMBLY

Fan shall be a belt drive assembly and include an adjustable pitch motor pulley. Job site selected brake horsepower shall not exceed the motors nameplate horsepower rating plus the service factor. Units shall be designed to operate within the service factor. Fan wheel shall be double inlet type with forward curve blades, dynamically balanced to operate smoothly throughout the entire range of operation. Design shall meet ASHRAE 90.1 single-zone variable supply air volume standard. Bearings shall be sealed and permanently lubricated for longer life and no maintenance. Entire blower assembly and motor shall be slide out design.

### OUTDOOR (CONDENSER) FAN ASSEMBLY

The outdoor fans shall be of the direct drive type, discharge air vertically, have aluminum blades riveted to corrosion resistant steel spider brackets and shall be dynamically balanced for smooth operation. The outdoor fan motors shall have permanently lubricated bearings internally protected against overload conditions and staged independently. A cleaning window shall be provided on two sides of the units for coil cleaning.

### REFRIGERANT COMPONENTS

#### Compressors:

- a. Shall be fully 2-stage, hermetic type, direct drive, internally protected with internal high-pressure relief and over temperature protection. The hermetic motor shall be suction gas cooled and have a voltage range of + or – 10% of the unit nameplate voltage.
- b. Shall have internal spring isolation and sound muffling to minimize vibration and noise, and be externally isolated on a dedicated, independent mounting.

#### Coils:

- a. Evaporator coils shall have aluminum plate fins mechanically bonded to seamless internally enhanced copper tubes with all joints brazed. Special Phenolic coating shall be available as a factory option.
- b. Evaporator coils shall be of the direct expansion, draw-thru design.
- c. Condenser coils shall have Micro-Channel aluminum tube, aluminum fins.
- d. Condenser coils shall be of the draw-thru design.

Refrigerant Circuit and Refrigerant Safety Components shall include:

- a. Independent fixed-orifice or thermally operated expansion devices.
- b. Solid core filter drier/strainer to eliminate any moisture or foreign matter.
- c. Accessible service gage connections on both suction and discharge lines to charge, evacuate, and measure refrigerant pressure during any necessary servicing or troubleshooting, without losing charge.

**Unit Controls:**

- a. Unit shall be complete with self-contained low-voltage control circuit protected by a resettable circuit breaker on the 24-volt transformer side.
- b. Unit shall incorporate a lockout circuit which provides reset capability at the space thermostat or base unit, should any of the following standard safety devices trip and shut off compressor.
  1. Loss-of-charge/Low-pressure switch.
  2. High-pressure switch.
  3. Freeze condition sensor on evaporator coil. If any of these safety devices trip, the LCD screen will display the alarm message.
- c. Unit shall incorporate "AUTO RESET" compressor over temperature, over current protection.
- d. Unit shall operate with conventional thermostat designs and have a low voltage terminal strip for easy hook-up.
- e. Unit control board shall have on-board diagnostics and fault message display.
- f. Standard controls shall include anti-short cycle and low voltage protection, and permit cooling operation down to a selectable value as low as 0 °F.
- g. Control board shall monitor each refrigerant safety switch independently.

**GAS HEATING SECTION (IF EQUIPPED)**

Heat exchanger and exhaust system shall be constructed of aluminized steel and shall be designed with induced draft combustion with post purge logic, energy saving direct spark ignition, and redundant main gas valve. The heat exchanger shall be of the tubular type, constructed of T1-40 aluminized steel for corrosion resistance and allowing minimum mixed air entering temperature of 40 °F. Burners shall be of the in-shot type, constructed of aluminum-coated steel. All gas piping shall enter the unit cabinet at a single location, through either the side or bottom, without any field modifications. An integrated control board shall provide timed control of evaporator fan functioning and burner ignition. Heating section shall be provided with the following minimum protection:

- a. Primary and auxiliary high-temperature limit switches.
- b. Induced draft pressure sensor.
- c. Flame roll out switch (manual reset).
- d. Flame proving controls.
- e. All two stage gas units shall have two independent stages of capacity (70% or 75% 1st stage, 100% 2nd stage).

**ELECTRIC HEATING SECTION (IF EQUIPPED)**

An electric heating section, with nickel chromium elements, shall be provided in a range of 3 thru 24KW. The heating section shall have a primary limit control(s) (automatic reset) to prevent the heating element system from operating at an

excessive temperature. The Heating Section assembly shall slide out of the unit for easy maintenance and service. Units with Electric Heating Sections shall be wired for a single point power supply with branch circuit fusing (where required).

**UNIT OPERATING CHARACTERISTICS**

Unit shall be capable of starting and running at 125 °F outdoor temperature, exceeding maximum load criteria of AHRI Standard 340/360. The compressor, with standard controls, shall be capable of operation down to 0 °F outdoor temperature. Unit shall be provided with fan time delay to prevent cold air delivery before heat exchanger warms up. (Gas heat only)

**ELECTRICAL REQUIREMENTS** - All unit power wiring shall enter unit cabinet at a single factory provided location and be capable of side or bottom entry to minimize roof penetrations and avoid unit field modifications. Separate side and bottom openings shall be provided for the control wiring.

**STANDARD LIMITED WARRANTIES** - Compressor – 5 Years, Heat Exchanger – 10 Years, Elect. Heat Elem. – 5 Years, Parts – 1 Year

**FACTORY INSTALLED OPTIONAL OUTDOOR AIR** (Shall be made available by either/or):

- **DRY BULB AUTOMATIC ECONOMIZER** - Outdoor and return air dampers that are interlocked and positioned by a fully-modulating, spring-return damper actuator. The maximum leakage rate for the outdoor air intake dampers shall be designed to meet ASHRAE 90.1-2010, AMCA 511 Class 1A damper, and the International Energy Conservation Code (IECC) certification requirements by achieving leakage rates of 3 cfm/sq. ft. at 1" of static pressure. Changeover from compressor to economizer operation shall be provided by an integral electronic enthalpy control that feeds input into the basic module. The outdoor intake opening shall be covered with a rain hood that matches the exterior of the unit. Water eliminator/filters shall be provided. Simultaneous economizer/compressor operation is also possible. Dampers shall fully close on power loss. Available with barometric relief and power exhaust.
- **MOTORIZED OUTDOOR AIR DAMPERS** - Outdoor and return air dampers that are interlocked and positioned by a 2- position, spring-return damper actuator. A unit-mounted potentiometer shall be provided to adjust the outdoor and return air damper assembly to take in the design CFM of outdoor air to meet the ventilation requirements of the conditioned space during normal operation. Whenever the indoor fan motor is energized, the dampers open up to one of two pre-selected positions - regardless of the outdoor air enthalpy. Dampers return to the fully closed position when the indoor fan motor is de-energized. Dampers shall fully close on power loss.

**ADDITIONAL FACTORY INSTALLED OPTIONS**

- **ALTERNATE INDOOR BLOWER MOTOR** – For applications with high restrictions, units are available with

optional indoor blower motors that provide higher static output and/or higher airflow.

- **CONVENIENCE OUTLET (POWERED/NON-POWERED)**– Unit can be provided with an optional 120VAC GFCI outlet with cover on the corner of the unit housing the compressors.
- **ELECTRIC HEAT** - Electric Heaters range from 3kW to 24kW and are available in all the voltage options of the base unit.
- **PHASE MONITOR** - Designed to prevent damage in out-of-phase condition.
- **COIL GUARD** - Designed to prevent condenser coil damage.
- **BAS CONTROLS HARDWARE** - Include supply air sensor, return air sensor, dirty filter indicator and air proving switch.
- **DIRTY FILTER SWITCH** – This kit includes a differential pressure switch that energizes the fault light on the unit thermostat, indicating that there is an abnormally high-pressure drop across the filters.
- **BREAKER** – An HACR breaker can be factory installed on gas heat units or cooling units with electric heat.
- **DISCONNECT SWITCH** - A disconnect can be factory installed on a cooling only units sized for the largest electric heat available.

- **STAINLESS STEEL HEAT EXCHANGER** – For applications in a corrosive environment, this option provides a full stainless steel heat exchanger assembly.
- **SMOKE DETECTOR** – A smoke detector can be factory mounted and wired in the supply and/or return air compartments.

#### **OTHER PRE-ENGINEERED ACCESSORIES AVAILABLE**

- **ROOF CURB** - 14" and 8" high, full perimeter knockdown curb, with hinged design for quick assembly.
- **BAROMETRIC RELIEF DAMPER** – (Unit mounted – Downflow, Duct Mounted – Horizontal) – Contains a rain hood, air inlet screen, exhaust damper and mounting hardware. Used to relieve internal air pressure through the unit during economizer operation.
- **PROPANE CONVERSION KIT** – Contains new orifices and gas valve springs to convert from natural to L.P. gas.
- **-60°F GAS HEAT KIT** – Provides an electric heat kit for the gas compartment for use in extreme low ambient conditions.
- **ECONOMIZER** (Downflow and Horizontal flow)
- **POWER EXHAUST** – (Unit mount – Downflow, Duct mount – Horizontal flow)
- **DUAL ENTHALPY KIT** - Provides a second input to economizer to monitor return air.



## Physical Data

### ZV-A3 thru -A5 Single Stage Gas Physical Data

Component	Models								
	ZV-A3			ZV-A4			ZV-A5		
Nominal Tonnage	3.0			4.0			5.0		
<b>AHRI COOLING PERFORMANCE</b>									
Gross Capacity @ AHRI A point (MBh)	39000			54000			66000		
AHRI net capacity (MBh)	38000			52000			64000		
EER	14.15			14.35			13.85		
SEER	18.1			18			17.5		
IPLV	-			-			-		
Nominal CFM	1200			1600			2000		
System power (KW)	2.70			3.64			4.62		
Refrigerant type	R-410A			R-410A			R-410A		
Refrigerant charge (lb-oz)									
System 1	9-12			13-2			12-7		
System 2	-			-			-		
<b>AHRI HEATING PERFORMANCE</b>									
Heating model	A06	A08	A11	A06	A08	A11	A08	A11	A16
Heat input (K Btu)	60	80	120	60	80	120	80	120	160
Heat output (K Btu)	49	65	97	49	65	97	65	97	129
AFUE %	-	-	-	-	-	-	-	-	-
Steady state efficiency (%)	81.5	81	81	81.5	81	81	81	81	80.5
No. burners	4	4	6	4	4	6	4	6	8
No. stages	1	1	1	1	1	1	1	1	1
Temperature Rise Range (°F)	20-50°F	25-65°F	35-80°F	20-50°F	25-65°F	35-80°F	25-65°F	35-80°F	45-75°F
Gas Limit Setting (°F)	200	235	290	200	235	290	235	290	240
Gas piping connection (in.)	3/4	3/4	3/4	3/4	3/4	3/4	3/4	3/4	3/4
<b>DIMENSIONS (inches)</b>									
Length	89			89			89		
Width	59			59			59		
Height	42			42			42		
<b>OPERATING WT. (lbs.)</b>	922			960			968		
<b>COMPRESSORS</b>									
Type	2-stage scroll			2-stage scroll			2-stage scroll		
Quantity	1			1			1		
Unit Capacity Steps (%)	67/100			67/100			67/100		
<b>CONDENSER COIL DATA</b>									
Face area (Sq. Ft.)	12.2			12.2			12.2		
Rows	1			1			1		
Fins per inch	23			23			23		
Tube diameter (in./MM)	.98/25			.98/25			.98/25		
Circuitry Type	2-pass Microchannel			2-pass Microchannel			2-pass Microchannel		
<b>EVAPORATOR COIL DATA</b>									
Face area (Sq. Ft.)	10.56			10.56			10.56		
Rows	3			4			4		
Fins per inch	15			15			15		
Tube diameter	0.375			0.375			0.375		
Refrigerant control	TXV			TXV			TXV		

**ZV-A3 thru -A5 Single Stage Gas Physical Data (Continued)**

Component	Models								
	ZV-A3			ZV-A4			ZV-A5		
Nominal Tonnage	3.0			4.0			5.0		
<b>CONDENSER FAN DATA</b>									
Quantity of fans	2			2			2		
Fan diameter (Inch)	24			24			24		
Type	Prop			Prop			Prop		
Drive type	Direct ECM			Direct ECM			Direct ECM		
Quantity of motors	2			2			2		
Motor HP each	1/3			1/3			1/3		
No. speeds	Var.			Var.			Var.		
RPM	850			850			850		
Nominal total CFM	7000			7000			7000		
<b>BELT DRIVE EVAP FAN DATA</b>									
Quantity	1			1			1		
Fan Size (Inch)	12 x 9			12 x 9			12 x 9		
Type	Centrifugal			Centrifugal			Centrifugal		
Motor Sheave	1VL40		1VL40	1VL34		1VL44	1VL40		1VM50
Blower Sheave	AK79		AK61	AK64		AK69	AK61		AK64
Belt	A47		A45	A47		A47	A45		A47
Motor HP each	1-1/2		1-1/2	1-1/2		1-1/2	1-1/2		2
RPM	1725		1725	1725		1725	1725		1725
Frame size	56		56	56		56	56		56
<b>FILTERS</b>									
Quantity - Size	4 - (24 x 16 x 2) <sup>1,2</sup>			4 - (24 x 16 x 2) <sup>1,2</sup>			4 - (24 x 16 x 2) <sup>1,2</sup>		
	4 - (24 x 16 x 4) <sup>3</sup>			4 - (24 x 16 x 4) <sup>3</sup>			4 - (24 x 16 x 4) <sup>3</sup>		

1. 2 In. Throwaway, Standard, MERV (Minimum Efficiency Reporting Value)
2. 2 In. Pleated, Optional, MERV 7.
3. 4 In. Pleated, Optional, MERV 13.

## ZV-A3 thru -A5 Two Stage Gas Physical Data

Component	Models								
	ZV-A3			ZV-A4			ZV-A5		
Nominal Tonnage	3.0			4.0			5.0		
<b>AHRI COOLING PERFORMANCE</b>									
Gross Capacity @ AHRI A point (MBh)	39000			54000			66000		
AHRI net capacity (MBh)	38000			52000			64000		
EER	14.15			14.35			13.85		
SEER	18.1			18			17.5		
IPLV	-			-			-		
Nominal CFM	1200			1600			2000		
System power (KW)	2.70			3.64			4.62		
Refrigerant type	R-410A			R-410A			R-410A		
Refrigerant charge (lb-oz)									
System 1	9-12			13-2			12-7		
System 2	-			-			-		
<b>AHRI HEATING PERFORMANCE</b>									
Heating model	N06	N08	N11	N06	N08	N11	N08	N11	N16
Heat input (K Btu)	60	80	120	60	80	120	80	120	160
Heat output (K Btu)	49	65	97	49	65	97	65	97	129
AFUE %	-		-	-		-	-		-
Steady state efficiency (%)	81.5	81	81	81.5	81	81	81	81	80.5
No. burners	4	4	6	4	4	6	4	6	8
No. stages	2 <sup>1</sup>	2 <sup>2</sup>	2 <sup>2</sup>	2 <sup>1</sup>	2 <sup>2</sup>	2 <sup>2</sup>	2 <sup>2</sup>	2 <sup>2</sup>	2 <sup>2</sup>
Temperature Rise Range (°F)	20-50°F	25-65°F	35-80°F	20-50°F	25-65°F	35-80°F	25-65°F	35-80°F	45-75°F
Gas Limit Setting (°F)	200	235	290	200	235	290	235	290	240
Gas piping connection (in.)	3/4	3/4	3/4	3/4	3/4	3/4	3/4	3/4	3/4
<b>DIMENSIONS (inches)</b>									
Length	89			89			89		
Width	59			59			59		
Height	42			42			42		
<b>OPERATING WT. (lbs.)</b>									
	922			960			968		
<b>COMPRESSORS</b>									
Type	2-stage scroll			2-stage scroll			2-stage scroll		
Quantity	1			1			1		
Unit Capacity Steps (%)	67/100			67/100			67/100		
<b>CONDENSER COIL DATA</b>									
Face area (Sq. Ft.)	12.2			12.2			12.2		
Rows	1			1			1		
Fins per inch	23			23			23		
Tube diameter (in./MM)	.98/25			.98/25			.98/25		
Circuitry Type	2-pass Microchannel			2-pass Microchannel			2-pass Microchannel		
<b>EVAPORATOR COIL DATA</b>									
Face area (Sq. Ft.)	10.56			10.56			10.56		
Rows	3			4			4		
Fins per inch	15			15			15		
Tube diameter	0.375			0.375			0.375		
Refrigerant control	TXV			TXV			TXV		

## ZV-A3 thru -A5 Two Stage Gas Physical Data (Continued)

Component	Models								
	ZV-A3			ZV-A4			ZV-A5		
Nominal Tonnage	3.0			4.0			5.0		
<b>CONDENSER FAN DATA</b>									
Quantity of fans	2			2			2		
Fan diameter (Inch)	24			24			24		
Type	Prop			Prop			Prop		
Drive type	Direct ECM			Direct ECM			Direct ECM		
Quantity of motors	2			2			2		
Motor HP each	1/3			1/3			1/3		
No. speeds	Var.			Var.			Var.		
RPM	850			850			850		
Nominal total CFM	7000			7000			7000		
<b>BELT DRIVE EVAP FAN DATA</b>									
Quantity	1			1			1		
Fan Size (Inch)	12 x 9			12 x 9			12 x 9		
Type	Centrifugal			Centrifugal			Centrifugal		
Motor Sheave	1VL40		1VL40	1VL34		1VL44	1VL40		1VM50
Blower Sheave	AK79		AK61	AK64		AK69	AK61		AK64
Belt	A47		A45	A47		A47	A45		A47
Motor HP each	1-1/2		1-1/2	1-1/2		1-1/2	1-1/2		2
RPM	1725		1725	1725		1725	1725		1725
Frame size	56		56	56		56	56		56
<b>FILTERS</b>									
Quantity - Size	4 - (24 x 16 x 2) <sup>3,4</sup>			4 - (24 x 16 x 2) <sup>3,4</sup>			4 - (24 x 16 x 2) <sup>3,4</sup>		
	4 - (24 x 16 x 4) <sup>5</sup>			4 - (24 x 16 x 4) <sup>5</sup>			4 - (24 x 16 x 4) <sup>5</sup>		

1. 1<sup>st</sup> Stage Capacity is 75% of Full Capacity.
2. 1<sup>st</sup> Stage Capacity is 70% of Full Capacity.
3. 2 In. Throwaway, Standard, MERV (Minimum Efficiency Reporting Value)
4. 2 In. Pleated, Optional, MERV 7.
5. 4 In. Pleated, Optional, MERV 13.



**ZV-A3 thru -A5 Unit Limitations**

Size (Tons)	Model	Unit Voltage	Unit Limitations		
			Applied Voltage		Outdoor DB Temp
			Min	Max	Max (°F)
-A3 (3)	ZV	208/230-3-60	187	252	125
		460-3-60	432	504	125
		575-3-60	540	630	125
-A4 (4)	ZV	208/230-3-60	187	252	125
		460-3-60	432	504	125
		575-3-60	540	630	125
-A5 (5)	ZV	208/230-3-60	187	252	125
		460-3-60	432	504	125
		575-3-60	540	630	125

# Capacity Performance

## ZV-A3 thru -A5 Cooling Capacities

### ZV-A3 High Speed Compressor (3.0 Ton)

Air on Evaporator Coil		Temperature of Air on Condenser Coil															
CFM	WB (°F)	Total Capacity <sup>1</sup> (MBh)	Total Input (kW) <sup>2</sup>	Sensible Capacity (MBh)						Total Capacity <sup>1</sup> (MBh)	Total Input (kW) <sup>2</sup>	Sensible Capacity (MBh)					
				Return Dry Bulb (°F)								Return Dry Bulb (°F)					
				90	85	80	75	70	65			90	85	80	75	70	65
				75°F						85°F							
750	77	49.3	1.9	25.0	20.9	16.7	-	-	-	45.5	2.2	22.1	19.0	15.9	-	-	-
	72	43.4	1.9	28.1	24.1	20.2	16.2	-	-	40.8	2.1	26.7	23.0	19.3	15.6	-	-
	67	37.4	1.9	31.2	27.4	23.6	19.5	15.9	-	36.1	2.1	31.2	27.0	22.7	18.8	15.0	-
	62	35.5	1.9	35.4	31.2	27.1	22.6	19.5	15.7	34.0	2.1	33.8	30.0	26.1	21.8	18.1	14.1
900	77	49.8	1.9	26.8	21.8	16.8	-	-	-	46.2	2.2	24.7	20.3	15.9	-	-	-
	72	44.7	1.9	30.6	25.9	21.3	16.6	-	-	42.1	2.1	29.2	24.8	20.3	15.8	-	-
	67	39.6	1.9	34.3	30.0	25.7	20.9	16.4	-	38.0	2.1	33.8	29.3	24.7	20.0	15.4	-
	62	37.5	1.9	37.4	33.8	30.2	25.0	20.9	16.2	35.8	2.1	35.7	32.4	29.1	24.0	19.5	14.8
	57	35.4	1.9	35.4	35.4	34.7	30.0	25.3	20.6	33.6	2.1	33.6	33.6	33.5	28.6	23.7	18.7
1050	77	50.4	2.0	28.6	22.7	16.8	-	-	-	47.0	2.2	27.3	21.6	15.9	-	-	-
	72	46.0	1.9	33.0	27.7	22.3	17.0	-	-	43.5	2.2	31.8	26.5	21.3	16.0	-	-
	67	41.7	1.9	37.4	32.7	27.9	22.3	17.0	-	40.0	2.1	36.4	31.5	26.7	21.2	15.8	-
	62	39.5	1.9	39.4	36.4	33.4	27.4	22.2	16.7	37.7	2.1	37.5	34.8	32.1	26.3	21.0	15.4
	57	37.2	1.9	37.2	37.2	36.9	33.2	27.5	21.8	35.3	2.1	35.3	35.3	35.3	31.8	26.1	20.4
1200	77	50.9	2.0	30.4	23.6	16.8	-	-	-	47.7	2.2	29.9	22.9	15.9	-	-	-
	72	47.4	1.9	35.5	29.4	23.4	17.4	-	-	44.8	2.2	34.4	28.3	22.2	16.2	-	-
	67	43.8	1.9	40.6	35.3	30.0	23.7	17.5	-	41.9	2.2	39.0	33.8	28.6	22.4	16.2	-
	62	41.4	1.9	41.3	39.0	36.6	29.8	23.6	17.1	39.5	2.1	39.4	37.2	35.0	28.6	22.4	16.1
	57	39.0	1.9	39.0	39.0	39.0	36.5	29.7	23.0	37.1	2.1	37.1	37.1	37.1	35.0	28.5	22.1
1350	72	48.7	2.0	37.9	31.2	24.5	17.8	-	-	46.1	2.2	37.0	30.1	23.2	16.3	-	-
	67	46.0	2.0	43.7	37.9	32.1	25.0	18.0	-	43.8	2.2	41.6	36.1	30.6	23.6	16.6	-
	62	43.4	1.9	43.3	41.5	39.8	32.2	25.0	17.6	41.3	2.1	41.2	39.6	38.0	30.8	23.8	16.7
	57	40.8	1.9	40.8	40.8	40.8	39.7	32.0	24.3	38.9	2.1	38.9	38.9	38.9	38.2	31.0	23.8
1500	72	50.0	2.0	40.4	33.0	25.6	18.2	-	-	47.5	2.2	39.6	31.9	24.2	16.5	-	-
	67	48.1	2.0	46.8	40.5	34.3	26.4	18.6	-	45.7	2.2	44.1	38.4	32.6	24.8	17.0	-
	62	45.3	1.9	45.3	44.1	42.9	34.7	26.4	18.1	43.2	2.2	43.1	42.0	40.9	33.1	25.2	17.3
	57	42.5	1.9	42.5	42.5	42.5	42.5	34.2	25.5	40.6	2.1	40.6	40.6	40.6	40.6	33.4	25.4
				95°F						105°F							
750	77	41.7	2.4	19.2	17.1	15.0	-	-	-	39.3	2.7	18.9	16.8	14.8	-	-	-
	72	38.3	2.3	25.2	21.8	18.4	15.0	-	-	35.4	2.7	24.0	20.8	17.5	14.2	-	-
	67	34.8	2.3	31.2	26.5	21.8	18.0	14.2	-	31.7	2.7	29.2	24.7	20.2	16.7	13.1	-
	62	32.4	2.3	32.2	28.7	25.2	21.0	16.8	12.6	30.3	2.7	30.0	26.5	22.9	19.1	15.3	11.5
900	77	42.6	2.4	22.6	18.8	15.0	-	-	-	39.5	2.7	22.1	18.3	14.5	-	-	-
	72	39.6	2.4	27.9	23.6	19.3	15.0	-	-	36.5	2.7	26.6	22.4	18.2	14.0	-	-
	67	36.5	2.3	33.3	28.5	23.6	19.0	14.5	-	33.5	2.7	31.1	26.5	21.9	17.6	13.2	-
	62	34.1	2.3	34.0	31.0	28.0	23.1	18.2	13.4	31.8	2.7	31.6	28.6	25.6	21.1	16.6	12.1
	57	31.8	2.3	31.8	31.8	31.8	27.2	22.0	16.9	30.2	2.7	30.2	30.2	29.4	24.7	20.0	15.3
1050	77	43.6	2.4	26.0	20.4	14.9	-	-	-	39.8	2.7	25.3	19.8	14.2	-	-	-
	72	40.9	2.4	30.7	25.4	20.2	15.0	-	-	37.7	2.7	29.2	24.0	18.9	13.8	-	-
	67	38.2	2.4	35.4	30.4	25.5	20.1	14.7	-	35.3	2.7	33.0	28.3	23.6	18.5	13.3	-
	62	35.9	2.3	35.7	33.2	30.7	25.2	19.7	14.2	33.4	2.7	33.2	30.8	28.4	23.1	17.9	12.7
	57	33.5	2.3	33.5	33.5	33.5	30.3	24.7	19.0	31.6	2.7	31.6	31.6	31.6	27.8	22.5	17.2
1200	77	44.6	2.4	29.4	22.1	14.9	-	-	-	40.1	2.7	28.6	21.2	13.9	-	-	-
	72	42.3	2.4	33.4	27.2	21.1	14.9	-	-	38.8	2.7	31.7	25.7	19.6	13.6	-	-
	67	40.0	2.4	37.4	32.3	27.3	21.1	15.0	-	37.0	2.7	34.9	30.1	25.4	19.4	13.4	-
	62	37.6	2.4	37.4	35.4	33.5	27.3	21.1	15.0	35.0	2.7	34.8	33.0	31.1	25.2	19.2	13.3
	57	35.2	2.3	35.2	35.2	35.2	33.5	27.3	21.1	32.9	2.7	32.9	32.9	32.9	31.0	25.1	19.2
1350	72	43.6	2.4	36.1	29.0	22.0	14.9	-	-	40.0	2.7	34.3	27.3	20.3	13.3	-	-
	67	41.7	2.4	39.5	34.3	29.1	22.1	15.2	-	38.8	2.7	36.8	31.9	27.1	20.3	13.5	-
	62	39.3	2.4	39.2	37.7	36.2	29.4	22.6	15.8	36.6	2.7	36.4	35.1	33.9	27.2	20.5	13.9
	57	37.0	2.3	37.0	37.0	37.0	36.6	30.0	23.3	34.3	2.7	34.3	34.3	34.3	34.1	27.6	21.1
1500	72	44.9	2.4	38.8	30.8	22.9	14.9	-	-	41.1	2.7	36.9	29.0	21.0	13.1	-	-
	67	43.4	2.4	41.5	36.2	30.9	23.2	15.4	-	40.6	2.8	38.7	33.8	28.8	21.2	13.5	-
	62	41.0	2.4	40.9	39.9	39.0	31.5	24.0	16.6	38.1	2.7	38.0	37.3	36.6	29.2	21.9	14.5
	57	38.7	2.3	38.7	38.7	38.7	38.7	32.6	25.4	35.7	2.7	35.7	35.7	35.7	35.7	30.2	23.1

## ZV-A3 High Speed Compressor (3.0 Ton) (Continued)

Air on Evaporator Coil		Temperature of Air on Condenser Coil															
CFM	WB (°F)	Total Capacity <sup>1</sup> (MBh)	Total Input (kW) <sup>2</sup>	Sensible Capacity (MBh)						Total Capacity <sup>1</sup> (MBh)	Total Input (kW) <sup>2</sup>	Sensible Capacity (MBh)					
				Return Dry Bulb (°F)								Return Dry Bulb (°F)					
				90	85	80	75	70	65			90	85	80	75	70	65
				115°F						125°F							
750	77	36.9	3.0	18.6	16.5	14.5	-	-	-	34.4	3.3	18.2	16.3	14.3	-	-	-
	72	32.4	3.0	22.8	19.7	16.6	13.4	-	-	29.5	3.3	21.6	18.6	15.6	12.6	-	-
	67	28.6	3.0	27.1	22.8	18.6	15.3	12.0	-	25.4	3.4	25.0	21.0	16.9	13.9	10.9	-
	62	28.1	3.0	27.8	24.2	20.6	17.2	13.8	10.3	26.0	3.3	25.7	22.0	18.3	15.2	12.2	9.2
900	77	36.4	3.0	21.6	17.8	14.0	-	-	-	33.3	3.3	21.2	17.3	13.5	-	-	-
	72	33.4	3.0	25.2	21.2	17.1	13.0	-	-	30.4	3.4	23.9	19.9	16.0	12.0	-	-
	67	30.4	3.0	28.8	24.5	20.2	16.1	11.9	-	27.4	3.4	26.6	22.5	18.5	14.6	10.7	-
	62	29.5	3.0	29.3	26.3	23.3	19.1	14.9	10.7	27.2	3.3	26.9	24.0	21.0	17.1	13.3	9.4
	57	28.6	3.0	28.6	28.1	26.4	22.2	17.9	13.7	27.1	3.3	27.1	25.4	23.5	19.7	15.9	12.1
1050	77	36.0	3.0	24.7	19.1	13.4	-	-	-	32.2	3.3	24.1	18.4	12.6	-	-	-
	72	34.4	3.0	27.7	22.6	17.6	12.6	-	-	31.2	3.4	26.2	21.2	16.3	11.4	-	-
	67	32.3	3.0	30.6	26.2	21.8	16.8	11.9	-	29.3	3.4	28.2	24.1	20.0	15.2	10.4	-
	62	31.0	3.0	30.7	28.4	26.1	21.1	16.1	11.2	28.5	3.3	28.2	26.0	23.7	19.0	14.3	9.7
	57	29.6	3.0	29.6	29.6	29.6	25.3	20.4	15.5	27.7	3.3	27.7	27.7	27.4	22.8	18.3	13.7
1200	77	35.6	3.0	27.8	20.3	12.8	-	-	-	31.1	3.3	27.0	19.4	11.8	-	-	-
	72	35.4	3.0	30.1	24.1	18.2	12.2	-	-	32.0	3.4	28.4	22.6	16.7	10.8	-	-
	67	34.1	3.1	32.3	27.9	23.5	17.6	11.8	-	31.2	3.4	29.8	25.7	21.6	15.9	10.2	-
	62	32.4	3.0	32.1	30.5	28.8	23.1	17.3	11.6	29.8	3.3	29.5	28.0	26.5	20.9	15.4	9.9
	57	30.6	3.0	30.6	30.6	30.6	28.5	22.8	17.2	28.3	3.3	28.3	28.3	28.3	26.0	20.6	15.3
1350	72	36.4	3.0	32.5	25.6	18.7	11.8	-	-	32.8	3.4	30.7	23.9	17.1	10.3	-	-
	67	36.0	3.1	34.1	29.6	25.1	18.4	11.7	-	33.1	3.4	31.4	27.3	23.1	16.5	10.0	-
	62	33.8	3.0	33.6	32.6	31.5	25.0	18.5	12.0	31.0	3.4	30.8	30.0	29.2	22.8	16.5	10.1
	57	31.6	3.0	31.6	31.6	31.6	31.6	25.3	19.0	28.9	3.3	28.9	28.9	28.9	28.9	23.0	16.8
1500	72	37.4	3.1	34.9	27.1	19.2	11.4	-	-	33.6	3.4	-	25.2	17.4	9.7	-	-
	67	37.8	3.1	35.8	31.3	26.7	19.2	11.6	-	35.1	3.4	-	28.8	24.7	17.2	9.7	-
	62	35.2	3.0	35.0	34.6	34.3	27.0	19.7	12.4	32.3	3.4	-	32.0	31.9	24.7	17.5	10.3
	57	32.6	3.0	32.6	32.6	32.6	32.6	27.8	20.7	29.6	3.3	-	29.6	29.6	29.6	25.3	18.4

1. These capacities are gross ratings. For net capacity, deduct air blower motor, MBh = 3.415 x kW. Refer to the appropriate Blower Performance Table for the kW of the supply air blower motor.
2. These ratings include the condenser fan motors (total 1 kW) and the compressor motors but not the supply air blower motor.

ZV-A3 Low Speed Compressor (3.0 Ton)

Air on Evaporator Coil		Temperature of Air on Condenser Coil															
CFM	WB (°F)	Total Capacity <sup>1</sup> (MBh)	Total Input (kW) <sup>2</sup>	Sensible Capacity (MBh)						Total Capacity <sup>1</sup> (MBh)	Total Input (kW) <sup>2</sup>	Sensible Capacity (MBh)					
				Return Dry Bulb (°F)								Return Dry Bulb (°F)					
				90	85	80	75	70	65			90	85	80	75	70	65
				75°F						85°F							
750	77	38.7	1.2	19.8	16.4	13.1	-	-	-	35.0	1.4	18.5	15.0	11.5	-	-	-
	72	34.6	1.2	24.6	20.6	16.6	12.7	-	-	31.8	1.4	23.0	19.2	15.3	11.4	-	-
	67	30.5	1.2	29.3	24.8	20.2	16.3	12.5	-	28.6	1.4	27.5	23.3	19.1	15.2	11.3	-
	62	29.6	1.2	29.1	26.4	23.7	18.6	16.3	12.7	27.6	1.4	27.3	25.1	22.9	18.3	15.0	11.0
900	77	39.0	1.2	23.1	18.3	13.4	-	-	-	35.6	1.4	21.9	16.8	11.7	-	-	-
	72	35.7	1.2	27.1	22.4	17.8	13.1	-	-	33.0	1.4	25.5	20.9	16.4	11.8	-	-
	67	32.4	1.2	31.1	26.6	22.1	17.5	13.0	-	30.3	1.4	29.1	25.1	21.0	16.3	11.7	-
	62	31.3	1.2	30.9	28.7	26.5	20.9	17.6	13.1	29.2	1.4	28.9	27.3	25.7	20.4	16.2	11.5
	57	30.2	1.2	30.2	30.2	30.2	26.4	22.1	17.8	28.0	1.4	28.0	28.0	28.0	25.5	20.7	15.9
1050	77	39.4	1.2	26.5	20.1	13.8	-	-	-	36.2	1.4	25.2	18.6	11.9	-	-	-
	72	36.9	1.2	29.7	24.3	18.9	13.6	-	-	34.1	1.4	28.0	22.7	17.4	12.1	-	-
	67	34.3	1.2	32.9	28.5	24.1	18.8	13.5	-	32.0	1.4	30.7	26.8	22.9	17.5	12.1	-
	62	33.0	1.2	32.6	30.9	29.2	23.1	18.8	13.5	30.7	1.4	30.5	29.5	28.4	22.5	17.4	11.9
	57	31.6	1.2	31.6	31.6	31.6	29.2	24.0	18.9	29.5	1.4	29.5	29.5	29.5	28.3	22.7	17.0
1200	77	39.7	1.2	29.8	22.0	14.2	-	-	-	36.7	1.4	28.6	20.3	12.1	-	-	-
	72	38.0	1.2	32.2	26.2	20.1	14.0	-	-	35.2	1.4	30.5	24.5	18.5	12.5	-	-
	67	36.2	1.2	34.6	30.3	26.0	20.0	14.0	-	33.7	1.4	32.3	28.6	24.8	18.7	12.5	-
	62	34.6	1.2	34.4	33.2	32.0	25.4	20.0	13.9	32.3	1.4	32.1	31.7	31.2	24.6	18.6	12.3
	57	33.0	1.2	33.0	33.0	33.0	31.9	26.0	20.0	30.9	1.4	30.9	30.9	30.9	30.9	24.7	18.2
1350	72	39.1	1.2	34.8	28.0	21.3	14.5	-	-	36.4	1.4	32.9	26.2	19.5	12.8	-	-
	67	38.1	1.2	36.4	32.2	28.0	21.2	14.5	-	35.4	1.4	33.9	30.3	26.7	19.8	12.9	-
	62	36.3	1.2	36.1	35.4	34.8	27.7	21.2	14.4	33.9	1.4	33.8	33.8	33.8	26.7	19.8	12.7
	57	34.4	1.2	34.4	34.4	34.4	34.4	27.9	21.1	32.3	1.3	32.3	32.3	32.3	32.3	26.6	19.4
	72	40.2	1.2	-	29.9	22.4	15.0	-	-	37.5	1.3	-	28.0	20.6	13.1	-	-
1500	67	40.0	1.2	-	34.0	30.0	22.5	14.9	-	37.1	1.3	-	32.1	28.6	21.0	13.4	-
	62	37.9	1.1	-	37.7	37.5	29.9	22.4	14.8	35.5	1.3	-	35.4	35.4	28.8	21.0	13.1
	57	35.9	1.1	-	35.9	35.9	35.9	29.8	22.2	33.8	1.3	-	33.8	33.8	33.8	28.6	20.5
	77	31.4	1.6	17.3	13.6	9.9	-	-	-	27.8	1.9	18.0	13.9	9.9	-	-	-
750	72	29.0	1.6	21.5	17.8	14.0	10.2	-	-	26.1	1.9	20.7	17.0	13.3	9.6	-	-
	67	26.7	1.6	25.7	21.9	18.1	14.1	10.0	-	24.6	1.9	23.5	20.1	16.7	12.7	8.8	-
	62	25.6	1.6	25.4	23.8	22.2	17.9	13.7	9.4	24.1	1.9	23.3	21.7	20.1	15.9	11.8	7.6
	77	32.2	1.6	20.7	15.3	9.9	-	-	-	28.4	1.9	20.5	14.9	9.3	-	-	-
900	72	30.2	1.6	23.9	19.4	14.9	10.4	-	-	27.2	1.9	22.7	18.2	13.8	9.3	-	-
	67	28.2	1.6	27.2	23.5	19.9	15.2	10.4	-	26.0	1.9	24.8	21.5	18.3	13.7	9.0	-
	62	27.1	1.6	26.9	25.9	24.9	19.9	14.8	9.8	25.3	1.9	24.7	23.7	22.8	18.0	13.2	8.4
	57	25.9	1.6	25.9	25.9	25.9	24.6	19.3	14.0	24.6	1.9	24.5	24.5	24.5	22.3	17.4	12.5
	77	32.9	1.6	24.0	17.0	10.0	-	-	-	29.1	1.9	23.0	15.8	8.6	-	-	-
1050	72	31.3	1.6	26.3	21.1	15.9	10.7	-	-	28.3	1.9	24.6	19.4	14.2	9.0	-	-
	67	29.7	1.6	28.6	25.2	21.8	16.2	10.7	-	27.4	1.9	26.1	23.0	19.8	14.6	9.3	-
	62	28.5	1.6	28.4	28.0	27.6	21.8	16.0	10.2	26.5	1.8	26.0	25.7	25.5	20.1	14.7	9.2
	57	27.4	1.6	27.4	27.4	27.4	27.4	21.3	15.2	25.6	1.8	25.6	25.6	25.6	25.3	19.5	13.7
	77	33.7	1.6	27.4	18.7	10.0	-	-	-	29.7	1.9	25.6	16.8	7.9	-	-	-
1200	72	32.5	1.6	28.7	22.8	16.8	10.9	-	-	29.5	1.8	26.5	20.6	14.7	8.8	-	-
	67	31.2	1.6	30.0	26.8	23.6	17.3	11.1	-	28.8	1.8	27.4	24.4	21.4	15.5	9.5	-
	62	30.0	1.6	29.9	29.9	29.9	23.8	17.2	10.6	27.7	1.8	27.3	27.3	27.3	22.1	16.1	10.0
	57	28.8	1.6	28.8	28.8	28.8	28.8	23.4	16.5	26.6	1.8	26.6	26.6	26.6	26.6	21.6	15.0
	72	33.6	1.6	31.1	24.4	17.8	11.1	-	-	30.6	1.8	28.4	21.8	15.2	8.5	-	-
1350	67	32.8	1.6	31.5	28.5	25.4	18.4	11.4	-	30.2	1.8	28.7	25.8	23.0	16.4	9.7	-
	62	31.5	1.5	31.4	31.4	31.4	25.7	18.4	11.1	28.9	1.8	28.6	28.6	28.6	24.2	17.5	10.8
	57	30.2	1.5	30.2	30.2	30.2	30.2	25.4	17.7	27.7	1.8	27.7	27.7	27.7	23.7	16.2	
	72	34.8	1.5	-	26.1	18.7	11.3	-	-	31.7	1.8	-	23.0	15.6	8.3	-	-
1500	67	34.3	1.5	-	30.1	27.3	19.5	11.8	-	31.6	1.8	-	27.3	24.6	17.3	9.9	-
	62	33.0	1.5	-	32.9	32.9	27.7	19.6	11.5	30.1	1.8	-	30.0	30.0	26.3	18.9	11.6
	57	31.7	1.5	-	31.7	31.7	31.7	27.4	18.9	28.7	1.8	-	28.7	28.7	28.7	25.9	17.5



## ZV-A3 Low Speed Compressor (3.0 Ton) (Continued)

Air on Evaporator Coil		Temperature of Air on Condenser Coil															
CFM	WB (°F)	Total Capacity <sup>1</sup> (MBh)	Total Input (kW) <sup>2</sup>	Sensible Capacity (MBh)						Total Capacity <sup>1</sup> (MBh)	Total Input (kW) <sup>2</sup>	Sensible Capacity (MBh)					
				Return Dry Bulb (°F)								Return Dry Bulb (°F)					
				90	85	80	75	70	65			90	85	80	75	70	65
				115°F						125°F							
750	77	24.2	2.2	18.6	14.3	9.9	-	-	-	20.5	2.5	19.3	14.6	10.0	-	-	-
	72	23.1	2.2	20.0	16.3	12.6	8.9	-	-	20.1	2.5	19.2	15.6	11.9	8.3	-	-
	67	22.5	2.2	21.3	18.3	15.3	11.4	7.6	-	20.4	2.4	19.1	16.5	13.9	10.1	6.4	-
	62	22.5	2.1	21.3	19.6	18.0	13.9	9.9	5.9	21.0	2.4	19.2	17.5	15.8	11.9	8.0	4.1
900	77	24.7	2.2	20.3	14.5	8.6	-	-	-	20.9	2.5	-	14.0	7.9	-	-	-
	72	24.2	2.2	21.4	17.0	12.6	8.2	-	-	21.2	2.4	-	15.8	11.4	7.1	-	-
	67	23.7	2.1	22.4	19.5	16.6	12.2	7.7	-	21.5	2.4	-	17.5	15.0	10.7	6.3	-
	62	23.5	2.1	22.4	21.5	20.6	16.1	11.6	7.1	21.7	2.4	-	19.3	18.5	14.2	10.0	5.7
	57	23.2	2.1	22.4	22.4	22.4	20.1	15.5	10.9	21.9	2.4	-	20.3	20.3	17.8	13.6	9.4
1050	77	25.2	2.2	22.1	14.6	7.2	-	-	-	21.3	2.4	21.1	13.5	5.8	-	-	-
	72	25.3	2.1	22.8	17.7	12.6	7.4	-	-	22.3	2.4	21.1	16.0	10.9	5.8	-	-
	67	25.0	2.1	23.6	20.8	17.9	12.9	7.8	-	22.7	2.4	21.1	18.6	16.0	11.2	6.3	-
	62	24.4	2.1	23.6	23.4	23.3	18.3	13.3	8.3	22.4	2.4	21.2	21.2	21.1	16.5	11.9	7.3
	57	23.9	2.1	23.6	23.6	23.6	23.2	17.7	12.2	22.1	2.4	21.3	21.3	21.3	21.1	15.9	10.7
1200	77	25.7	2.1	23.8	14.8	5.8	-	-	-	21.7	2.4	21.7	12.9	3.7	-	-	-
	72	26.5	2.1	24.3	18.4	12.6	6.7	-	-	23.5	2.4	22.0	16.2	10.4	4.6	-	-
	67	26.3	2.1	24.7	22.0	19.3	13.6	7.9	-	23.8	2.4	22.1	19.6	17.1	11.7	6.3	-
	62	25.4	2.1	24.7	24.7	24.7	20.5	15.0	9.4	23.1	2.4	22.2	22.2	22.2	18.8	13.8	8.8
	57	24.5	2.1	24.5	24.5	24.5	24.5	19.9	13.5	22.3	2.4	22.3	22.3	22.3	22.3	18.2	12.0
1350	72	27.6	2.1	25.7	19.1	12.5	6.0	-	-	24.6	2.4	23.0	16.5	9.9	3.4	-	-
	67	27.5	2.1	25.9	23.2	20.6	14.3	8.0	-	24.9	2.4	23.1	20.6	18.2	12.2	6.3	-
	62	26.3	2.1	25.9	25.9	25.9	22.7	16.6	10.6	23.7	2.4	23.2	23.2	23.2	21.1	15.8	10.4
	57	25.1	2.1	25.1	25.1	25.1	25.1	22.1	14.8	22.5	2.4	22.5	22.5	22.5	22.5	20.5	13.3
1500	72	28.7	2.1	-	19.8	12.5	5.2	-	-	25.7	2.4	-	-	-	-	-	-
	67	28.8	2.1	-	24.5	21.9	15.0	8.1	-	26.1	2.4	-	-	-	-	-	-
	62	27.3	2.1	-	27.1	27.1	24.8	18.3	11.8	24.4	2.4	-	-	-	-	-	-
	57	25.7	2.1	-	25.7	25.7	25.7	24.3	16.1	22.7	2.4	-	-	-	-	-	-

1. These capacities are gross ratings. For net capacity, deduct air blower motor, MBh = 3.415 x kW. Refer to the appropriate Blower Performance Table for the kW of the supply air blower motor.
2. These ratings include the condenser fan motors (total 1 kW) and the compressor motors but not the supply air blower motor.

**ZV-A4 High Speed Compressor (4.0 Ton)**

Air on Evaporator Coil		Temperature of Air on Condenser Coil															
CFM	WB (°F)	Total Capacity <sup>1</sup> (MBh)	Total Input (kW) <sup>2</sup>	Sensible Capacity (MBh)						Total Capacity <sup>1</sup> (MBh)	Total Input (kW) <sup>2</sup>	Sensible Capacity (MBh)					
				Return Dry Bulb (°F)								Return Dry Bulb (°F)					
				90	85	80	75	70	65			90	85	80	75	70	65
				75°F						85°F							
1000	77	67.2	2.6	32.6	27.0	21.4	-	-	-	64.1	2.9	29.5	24.7	19.8	-	-	-
	72	60.1	2.5	38.7	33.3	27.9	22.5	-	-	57.1	2.8	36.6	31.4	26.2	21.0	-	-
	67	53.1	2.5	44.8	39.6	34.5	27.9	22.6	-	50.0	2.8	43.6	38.1	32.6	26.6	21.3	-
	62	49.5	2.5	49.4	45.2	41.0	32.4	28.1	21.7	47.4	2.8	47.3	43.1	39.0	31.8	26.7	20.6
1200	77	67.6	2.6	35.7	28.7	21.7	-	-	-	64.0	2.9	33.6	26.9	20.2	-	-	-
	72	61.3	2.6	42.0	35.6	29.3	22.9	-	-	57.9	2.9	40.1	33.8	27.5	21.3	-	-
	67	54.9	2.5	48.2	42.5	36.8	29.4	23.1	-	51.8	2.8	46.7	40.8	34.9	28.0	21.6	-
	62	52.1	2.5	52.0	48.1	44.3	35.3	29.7	22.5	49.8	2.8	49.7	46.0	42.3	34.4	28.3	21.3
1400	77	68.0	2.6	38.8	30.5	22.1	-	-	-	63.8	2.9	37.6	29.1	20.5	-	-	-
	72	62.4	2.6	45.2	37.9	30.6	23.3	-	-	58.7	2.9	43.6	36.3	28.9	21.5	-	-
	67	56.8	2.5	51.7	45.4	39.1	30.9	23.6	-	53.7	2.8	49.7	43.4	37.2	29.4	22.0	-
	62	54.7	2.5	54.5	51.0	47.6	38.2	31.3	23.2	52.3	2.8	52.1	48.8	45.6	37.0	29.8	21.9
1600	77	68.4	2.7	41.9	32.2	22.5	-	-	-	63.7	2.9	41.6	31.2	20.9	-	-	-
	72	63.5	2.6	48.5	40.2	31.9	23.6	-	-	59.6	2.9	47.1	38.7	30.2	21.7	-	-
	67	58.6	2.6	55.1	48.2	41.4	32.5	24.1	-	55.5	2.9	52.7	46.1	39.6	30.8	22.3	-
	62	57.3	2.6	57.1	54.0	50.8	41.0	32.9	24.0	54.7	2.8	54.4	51.7	48.9	39.7	31.3	22.5
1800	72	64.6	2.7	51.8	42.5	33.2	24.0	-	-	60.4	2.9	50.7	41.1	31.5	22.0	-	-
	67	60.4	2.6	58.5	51.1	43.7	34.0	24.6	-	57.3	2.9	55.7	48.8	41.9	32.2	22.6	-
	62	59.9	2.6	59.7	56.9	54.1	43.9	34.5	24.7	57.2	2.9	56.8	54.5	52.2	42.3	32.9	23.2
	57	59.4	2.6	59.2	59.2	59.2	54.5	44.4	34.4	57.1	2.8	57.1	57.1	57.1	52.8	43.1	33.3
2000	72	65.7	2.7	55.1	44.8	34.6	24.3	-	-	61.2	2.9	54.2	43.5	32.9	22.2	-	-
	67	62.2	2.6	61.9	54.0	46.0	35.5	25.1	-	59.2	2.9	58.7	51.5	44.2	33.6	23.0	-
	62	62.5	2.6	62.2	59.8	57.4	46.8	36.1	25.5	59.6	2.9	59.2	57.4	55.5	45.0	34.4	23.8
	57	62.8	2.6	62.5	62.5	62.5	58.0	47.2	36.3	60.1	2.9	59.7	59.7	59.7	56.3	45.8	35.3
				95°F						105°F							
1000	77	61.1	3.2	26.5	22.4	18.3	-	-	-	55.6	3.6	25.0	21.0	17.1	-	-	-
	72	54.0	3.1	34.5	29.5	24.5	19.5	-	-	49.9	3.6	33.1	28.1	23.0	18.0	-	-
	67	46.8	3.1	42.5	36.6	30.7	25.3	19.9	-	44.2	3.5	41.3	35.1	28.9	23.6	18.2	-
	62	45.3	3.1	45.2	41.1	36.9	31.1	25.3	19.6	42.9	3.6	42.8	38.8	34.9	29.2	23.5	17.9
1200	77	60.3	3.2	31.4	25.0	18.6	-	-	-	55.2	3.6	29.8	23.4	17.1	-	-	-
	72	54.5	3.2	38.3	32.0	25.8	19.6	-	-	50.5	3.6	36.6	30.4	24.2	18.0	-	-
	67	48.7	3.1	45.1	39.1	33.0	26.6	20.1	-	45.9	3.6	43.4	37.3	31.3	24.8	18.3	-
	62	47.6	3.1	47.4	43.8	40.3	33.5	26.8	20.1	45.0	3.6	44.8	41.6	38.3	31.6	24.9	18.2
1400	77	59.6	3.2	36.4	27.6	18.9	-	-	-	54.7	3.6	34.6	25.8	17.1	-	-	-
	72	55.1	3.2	42.0	34.6	27.2	19.7	-	-	51.2	3.6	40.0	32.7	25.3	17.9	-	-
	67	50.5	3.1	47.7	41.5	35.4	27.8	20.3	-	47.6	3.6	45.5	39.6	33.6	26.0	18.5	-
	62	49.9	3.1	49.6	46.6	43.6	35.9	28.3	20.6	47.1	3.6	46.7	44.3	41.8	34.1	26.3	18.6
1600	77	58.9	3.2	41.3	30.3	19.2	-	-	-	54.3	3.6	39.4	28.2	17.0	-	-	-
	72	55.6	3.2	45.8	37.1	28.5	19.8	-	-	51.8	3.6	43.5	35.0	26.5	17.9	-	-
	67	52.4	3.2	50.3	44.0	37.7	29.1	20.4	-	49.3	3.6	47.7	41.8	35.9	27.2	18.6	-
	62	52.2	3.1	51.8	49.4	47.0	38.3	29.7	21.1	49.2	3.6	48.7	47.0	45.3	36.5	27.8	19.0
1800	72	56.2	3.2	49.6	39.7	29.8	19.9	-	-	52.5	3.6	47.0	37.3	27.6	17.9	-	-
	67	54.3	3.2	52.9	46.5	40.1	30.3	20.6	-	51.0	3.6	49.8	44.0	38.2	28.5	18.7	-
	62	54.5	3.2	54.0	52.2	50.3	40.8	31.2	21.6	51.3	3.6	50.7	49.7	48.8	39.0	29.2	19.4
	57	54.8	3.1	54.8	54.8	54.8	51.2	41.7	32.3	51.6	3.6	51.6	51.6	51.6	49.5	39.6	29.7
2000	72	56.8	3.2	-	42.2	31.1	20.1	-	-	53.1	3.6	50.4	39.6	28.8	17.9	-	-
	67	56.1	3.2	55.5	48.9	42.4	31.6	20.8	-	52.7	3.6	51.9	46.2	40.5	29.7	18.8	-
	62	56.8	3.2	56.2	54.9	53.7	43.2	32.6	22.1	53.4	3.6	52.6	52.4	52.2	41.4	30.6	19.7
	57	57.5	3.2	56.9	56.9	56.9	54.7	44.5	34.2	54.2	3.6	53.4	53.4	53.4	53.1	42.3	31.4

## ZV-A4 High Speed Compressor (4.0 Ton) (Continued)

Air on Evaporator Coil		Temperature of Air on Condenser Coil															
		Total Capacity <sup>1</sup> (MBh)	Total Input (kW) <sup>2</sup>	Sensible Capacity (MBh)						Total Capacity <sup>1</sup> (MBh)	Total Input (kW) <sup>2</sup>	Sensible Capacity (MBh)					
Return Dry Bulb (°F)						Return Dry Bulb (°F)											
90	85			80	75	70	65	90	85			80	75	70	65		
		115°F								125°F							
1000	77	50.2	4.1	23.4	19.6	15.9	-	-	-	44.7	4.5	21.9	18.3	14.6	-	-	-
	72	45.9	4.0	31.8	26.6	21.5	16.4	-	-	41.8	4.5	30.4	25.2	20.0	14.9	-	-
	67	41.6	4.0	40.1	33.7	27.2	21.9	16.5	-	39.0	4.4	38.9	32.2	25.4	20.1	14.8	-
	62	40.4	4.0	40.4	36.6	32.9	27.3	21.7	16.2	38.0	4.5	37.9	34.4	30.8	25.4	19.9	14.5
1200	77	50.0	4.1	28.1	21.8	15.5	-	-	-	44.9	4.5	26.4	20.2	14.0	-	-	-
	72	46.6	4.0	34.9	28.7	22.5	16.3	-	-	42.6	4.5	33.2	27.0	20.8	14.6	-	-
	67	43.1	4.0	41.8	35.6	29.5	23.0	16.6	-	40.4	4.4	40.1	33.9	27.7	21.3	14.8	-
	62	42.4	4.0	42.1	39.3	36.4	29.8	23.1	16.4	39.7	4.5	39.5	37.0	34.5	27.9	21.2	14.6
	57	41.6	4.1	41.6	41.6	41.6	36.5	29.6	22.7	39.1	4.6	38.8	38.8	38.8	34.5	27.6	20.8
1400	77	49.9	4.1	32.7	24.0	15.2	-	-	-	45.0	4.5	30.9	22.1	13.3	-	-	-
	72	47.3	4.0	38.1	30.8	23.5	16.2	-	-	43.4	4.5	36.1	28.9	21.6	14.4	-	-
	67	44.7	4.0	43.4	37.6	31.8	24.2	16.7	-	41.7	4.5	41.2	35.6	29.9	22.4	14.9	-
	62	44.3	4.0	43.9	41.9	40.0	32.2	24.4	16.6	41.5	4.5	41.0	39.6	38.2	30.4	22.5	14.7
	57	43.9	4.1	43.9	43.9	43.9	40.3	32.2	24.2	41.2	4.6	40.7	40.7	40.7	38.4	30.2	22.1
1600	77	49.7	4.1	37.4	26.1	14.9	-	-	-	45.2	4.5	35.5	24.1	12.7	-	-	-
	72	48.0	4.1	41.2	32.8	24.4	16.1	-	-	44.2	4.5	38.9	30.7	22.4	14.2	-	-
	67	46.2	4.0	45.0	39.5	34.0	25.4	16.7	-	43.1	4.5	42.4	37.3	32.2	23.5	14.9	-
	62	46.2	4.0	45.6	44.6	43.6	34.7	25.8	16.9	43.2	4.5	42.5	42.2	41.9	32.9	23.8	14.8
	57	46.2	4.1	46.2	46.2	46.2	44.0	34.9	25.7	43.3	4.5	42.6	42.6	42.6	42.3	32.8	23.3
1800	72	48.7	4.1	44.4	34.9	25.4	15.9	-	-	45.0	4.5	41.8	32.5	23.2	13.9	-	-
	67	47.7	4.1	46.7	41.5	36.3	26.6	16.8	-	44.5	4.5	43.5	39.0	34.4	24.7	14.9	-
	62	48.1	4.1	47.3	47.3	47.2	37.2	27.1	17.1	45.0	4.5	44.0	44.0	44.0	35.4	25.1	14.9
	57	48.5	4.1	48.0	48.0	48.0	47.8	37.5	27.2	45.4	4.5	44.5	44.5	44.5	44.5	35.4	24.6
2000	72	49.5	4.1	47.5	37.0	26.4	15.8	-	-	45.8	4.5	-	34.3	24.0	13.7	-	-
	67	49.3	4.1	48.3	43.4	38.6	27.7	16.9	-	45.9	4.5	-	40.7	36.7	25.8	14.9	-
	62	50.1	4.1	49.1	49.1	49.1	39.6	28.5	17.4	46.7	4.5	-	45.5	45.5	37.9	26.4	15.0
	57	50.9	4.0	49.9	49.9	49.9	49.9	40.1	28.7	47.6	4.5	-	46.4	46.4	46.4	38.0	25.9

1. These capacities are gross ratings. For net capacity, deduct air blower motor, MBh = 3.415 x kW. Refer to the appropriate Blower Performance Table for the kW of the supply air blower motor.
2. These ratings include the condenser fan motors (total 1 kW) and the compressor motors but not the supply air blower motor.

**ZV-A4 Low Speed Compressor (4.0 Ton)**

Air on Evaporator Coil		Temperature of Air on Condenser Coil															
CFM	WB (°F)	Total Capacity <sup>1</sup> (MBh)	Total Input (kW) <sup>2</sup>	Sensible Capacity (MBh)						Total Capacity <sup>1</sup> (MBh)	Total Input (kW) <sup>2</sup>	Sensible Capacity (MBh)					
				Return Dry Bulb (°F)								Return Dry Bulb (°F)					
				90	85	80	75	70	65			90	85	80	75	70	65
				75°F						85°F							
1000	77	53.1	1.6	27.6	22.9	18.3	-	-	-	48.3	1.9	27.7	22.3	17.0	-	-	-
	72	46.5	1.6	33.7	28.4	23.1	17.8	-	-	43.0	1.9	32.7	27.2	21.8	16.4	-	-
	67	39.9	1.7	39.9	34.0	28.0	22.3	17.6	-	37.7	1.9	37.7	32.2	26.6	21.1	16.1	-
	62	40.1	1.7	40.0	36.4	32.9	25.3	22.6	17.5	37.6	1.9	37.6	34.5	31.5	25.1	21.2	16.0
1200	77	52.8	1.6	31.9	24.7	17.5	-	-	-	48.1	1.9	31.4	23.7	16.0	-	-	-
	72	47.4	1.6	36.9	30.5	24.0	17.6	-	-	43.8	1.9	35.4	29.0	22.5	16.1	-	-
	67	41.9	1.6	41.9	36.2	30.5	23.7	17.6	-	39.5	1.9	39.4	34.3	29.1	22.5	16.2	-
	62	42.1	1.6	42.0	39.5	37.0	28.6	24.1	17.7	39.5	1.9	39.4	37.6	35.7	28.2	22.7	16.2
1400	77	52.5	1.6	36.3	26.5	16.8	-	-	-	47.9	1.9	35.1	25.0	14.9	-	-	-
	72	48.2	1.6	40.1	32.5	24.9	17.3	-	-	44.6	1.9	38.1	30.7	23.2	15.8	-	-
	67	44.0	1.6	43.8	38.4	33.0	25.1	17.7	-	41.3	1.9	41.1	36.4	31.6	23.8	16.3	-
	62	44.2	1.6	44.1	42.6	41.1	32.0	25.7	18.0	41.5	1.9	41.3	40.6	39.9	31.3	24.2	16.3
1600	77	52.2	1.6	40.6	28.4	16.1	-	-	-	47.8	1.9	38.8	26.3	13.9	-	-	-
	72	49.1	1.6	43.2	34.5	25.8	17.1	-	-	45.4	1.9	40.8	32.4	24.0	15.5	-	-
	67	46.1	1.6	45.8	40.7	35.6	26.5	17.8	-	43.0	1.9	42.9	38.5	34.1	25.1	16.4	-
	62	46.2	1.6	46.1	45.7	45.3	35.3	27.2	18.2	43.4	1.9	43.1	43.1	43.1	34.4	25.7	16.5
1800	72	50.0	1.6	46.4	36.5	26.7	16.9	-	-	46.2	1.9	43.6	34.1	24.7	15.2	-	-
	67	48.1	1.6	47.7	42.9	38.1	27.9	17.9	-	44.8	1.9	44.6	40.6	36.5	26.5	16.5	-
	62	48.2	1.6	48.1	48.1	48.1	38.6	28.8	18.5	45.3	1.9	45.0	45.0	45.0	37.5	27.2	16.6
	57	48.3	1.6	48.3	48.3	48.3	48.3	39.7	29.1	45.7	1.9	45.4	45.4	45.4	45.4	37.9	26.7
2000	72	50.9	1.6	-	38.6	27.6	16.6	-	-	47.0	1.9	-	35.8	25.4	14.9	-	-
	67	50.2	1.6	-	45.1	40.6	29.3	18.0	-	46.6	1.9	-	42.7	39.0	27.8	16.6	-
	62	50.3	1.6	-	50.1	50.1	42.0	30.3	18.7	47.2	1.9	-	46.8	46.8	40.7	28.7	16.7
	57	50.4	1.6	-	50.4	50.4	50.4	42.7	30.7	47.8	1.9	-	47.4	47.4	47.4	40.8	28.1
				95°F						105°F							
1000	77	43.5	2.2	-	21.8	15.7	-	-	-	38.6	2.6	-	21.3	14.4	-	-	-
	72	39.5	2.2	-	26.1	20.5	15.0	-	-	35.9	2.6	-	24.9	19.3	13.6	-	-
	67	35.6	2.2	-	30.4	25.3	19.9	14.6	-	33.2	2.6	-	28.6	24.1	18.6	13.0	-
	62	35.2	2.2	-	32.6	30.1	24.9	19.8	14.6	32.8	2.6	-	30.9	29.0	23.5	18.1	12.7
1200	77	43.4	2.2	-	22.6	14.4	-	-	-	39.0	2.6	-	21.7	13.0	-	-	-
	72	40.3	2.2	-	27.5	21.0	14.6	-	-	36.7	2.6	-	26.0	19.5	13.1	-	-
	67	37.1	2.2	36.9	32.3	27.7	21.2	14.7	-	34.5	2.6	34.3	30.2	26.1	19.6	13.1	-
	62	37.0	2.2	36.8	35.6	34.4	27.8	21.2	14.6	34.4	2.6	34.2	33.5	32.7	26.1	19.5	13.0
1400	77	43.4	2.2	33.9	23.5	13.0	-	-	-	39.3	2.6	32.8	22.2	11.5	-	-	-
	72	41.0	2.2	36.2	28.9	21.6	14.3	-	-	37.5	2.6	34.2	27.0	19.8	12.6	-	-
	67	38.6	2.2	38.4	34.3	30.1	22.5	14.8	-	35.8	2.6	35.6	31.9	28.1	20.7	13.2	-
	62	38.7	2.2	38.5	38.5	38.5	30.7	22.7	14.7	36.0	2.6	35.7	35.7	35.7	28.7	21.0	13.2
1600	77	43.4	2.2	37.0	24.3	11.7	-	-	-	39.6	2.6	35.1	22.6	10.1	-	-	-
	72	41.7	2.2	38.5	30.3	22.1	13.9	-	-	38.3	2.6	36.1	28.1	20.1	12.1	-	-
	67	40.0	2.2	39.9	36.2	32.6	23.8	14.9	-	37.1	2.6	37.0	33.6	30.2	21.7	13.3	-
	62	40.5	2.2	40.2	40.2	40.2	33.6	24.1	14.7	37.7	2.6	37.2	37.2	37.2	31.3	22.4	13.5
1800	72	42.4	2.1	40.8	31.7	22.6	13.6	-	-	39.1	2.5	37.9	29.1	20.4	11.6	-	-
	67	41.5	2.1	41.4	38.2	35.0	25.0	15.1	-	38.5	2.5	38.3	35.2	32.2	22.8	13.4	-
	62	42.3	2.1	41.9	41.9	41.9	36.5	25.6	14.7	39.3	2.5	38.7	38.7	38.7	33.9	23.8	13.8
	57	43.1	2.1	42.4	42.4	42.4	42.4	36.1	24.3	40.1	2.5	39.2	39.2	39.2	34.3	23.6	
2000	72	43.2	2.1	-	33.1	23.2	13.3	-	-	39.9	2.5	-	30.2	20.7	11.1	-	-
	67	43.0	2.1	-	40.2	37.4	26.3	15.2	-	39.8	2.5	-	36.9	34.2	23.8	13.4	-
	62	44.1	2.1	-	43.6	43.6	39.4	27.1	14.7	40.9	2.5	-	40.2	40.2	36.5	25.3	14.0
	57	45.2	2.1	-	44.3	44.3	44.3	38.9	25.4	42.1	2.5	-	40.8	40.8	40.8	37.1	25.0



## ZV-A4 Low Speed Compressor (4.0 Ton) (Continued)

Air on Evaporator Coil		Temperature of Air on Condenser Coil															
CFM	WB (°F)	Total Capacity <sup>1</sup> (MBh)	Total Input (kW) <sup>2</sup>	Sensible Capacity (MBh)						Total Capacity <sup>1</sup> (MBh)	Total Input (kW) <sup>2</sup>	Sensible Capacity (MBh)					
				Return Dry Bulb (°F)								Return Dry Bulb (°F)					
				90	85	80	75	70	65			90	85	80	75	70	65
				115°F						125°F							
1000	77	33.8	3.0	-	20.8	13.1	-	-	-	28.9	3.4	-	20.4	11.8	-	-	-
	72	32.3	3.0	-	23.8	18.0	12.3	-	-	28.8	3.4	-	22.7	16.8	10.9	-	-
	67	30.8	3.0	-	26.7	23.0	17.2	11.5	-	28.4	3.4	-	24.9	21.8	15.9	10.0	-
	62	30.4	3.0	-	29.1	27.9	22.2	16.5	10.8	28.0	3.4	-	27.4	26.8	20.8	14.8	8.9
1200	77	34.5	3.0	-	20.8	11.6	-	-	-	30.0	3.4	-	20.0	10.2	-	-	-
	72	33.2	3.0	-	24.5	18.1	11.6	-	-	29.7	3.4	-	23.0	16.6	10.1	-	-
	67	31.9	3.0	31.7	28.1	24.5	18.0	11.5	-	29.3	3.4	-	26.0	23.0	16.5	10.0	-
	62	31.9	3.0	31.7	31.4	31.0	24.5	17.9	11.3	29.3	3.4	-	29.1	29.1	22.8	16.2	9.6
	57	31.8	3.0	31.6	31.6	31.6	30.9	24.2	17.6	29.3	3.4	-	29.1	29.1	29.1	22.5	15.8
1400	77	35.2	3.0	31.7	20.9	10.0	-	-	-	31.1	3.3	30.6	19.5	8.5	-	-	-
	72	34.0	3.0	32.3	25.2	18.1	11.0	-	-	30.6	3.4	30.3	23.3	16.3	9.3	-	-
	67	33.1	3.0	32.9	29.5	26.1	18.9	11.6	-	30.3	3.4	30.1	27.1	24.1	17.0	9.9	-
	62	33.3	3.0	33.0	33.0	33.0	26.7	19.3	11.8	30.6	3.4	30.2	30.2	30.2	24.8	17.6	10.4
	57	33.6	3.0	33.1	33.1	33.1	33.1	27.0	19.3	30.9	3.4	30.3	30.3	30.3	30.3	25.2	17.9
1600	77	35.9	2.9	33.3	20.9	8.5	-	-	-	32.1	3.3	31.4	19.1	6.9	-	-	-
	72	34.9	3.0	33.7	25.9	18.1	10.3	-	-	31.5	3.3	31.2	23.7	16.1	8.5	-	-
	67	34.2	3.0	34.0	30.9	27.7	19.7	11.6	-	31.3	3.4	31.1	28.2	25.3	17.6	9.9	-
	62	34.8	3.0	34.3	34.3	34.3	29.0	20.7	12.3	32.0	3.3	31.3	31.3	31.3	26.8	18.9	11.1
	57	35.4	2.9	34.5	34.5	34.5	34.5	29.7	21.1	32.6	3.3	31.5	31.5	31.5	31.5	27.9	20.0
1800	72	35.7	2.9	35.0	26.6	18.1	9.7	-	-	32.4	3.3	32.2	24.0	15.9	7.7	-	-
	67	35.4	2.9	35.2	32.3	29.3	20.5	11.6	-	32.3	3.3	32.1	29.3	26.5	18.2	9.9	-
	62	36.3	2.9	35.6	35.6	35.6	31.3	22.1	12.8	33.3	3.3	32.4	32.4	32.4	28.7	20.3	11.9
	57	37.2	2.9	35.9	35.9	35.9	35.9	32.5	22.8	34.2	3.3	32.7	32.7	32.7	32.7	30.7	22.1
2000	72	36.6	2.9	36.4	27.3	18.1	9.0	-	-	33.3	3.3	-	-	-	-	-	-
	67	36.5	2.9	36.4	33.7	30.9	21.3	11.7	-	33.3	3.3	-	-	-	-	-	-
	62	37.8	2.9	36.9	36.9	36.9	33.6	23.5	13.3	34.6	3.3	-	-	-	-	-	-
	57	39.0	2.9	37.4	37.4	37.4	37.4	35.2	24.6	35.9	3.3	-	-	-	-	-	-

1. These capacities are gross ratings. For net capacity, deduct air blower motor, MBh = 3.415 x kW. Refer to the appropriate Blower Performance Table for the kW of the supply air blower motor.
2. These ratings include the condenser fan motors (total 1 kW) and the compressor motors but not the supply air blower motor.

**ZV-A5 High Speed Compressor (5.0 Ton)**

Air on Evaporator Coil		Temperature of Air on Condenser Coil															
CFM	WB (°F)	Total Capacity <sup>1</sup> (MBh)	Total Input (kW) <sup>2</sup>	Sensible Capacity (MBh)						Total Capacity <sup>1</sup> (MBh)	Total Input (kW) <sup>2</sup>	Sensible Capacity (MBh)					
				Return Dry Bulb (°F)								Return Dry Bulb (°F)					
				90	85	80	75	70	65			90	85	80	75	70	65
				75°F						85°F							
1250	77	84.7	3.4	41.4	36.0	30.6	-	-	-	80.9	3.8	39.1	34.1	29.0	-	-	-
	72	75.5	3.4	49.5	43.0	36.5	30.0	-	-	71.6	3.7	47.5	41.2	34.8	28.5	-	-
	67	66.4	3.3	57.6	50.0	42.4	36.2	29.8	-	62.3	3.7	56.0	48.3	40.7	34.4	28.0	-
	62	61.3	3.2	61.0	54.6	48.3	40.7	36.0	29.9	59.1	3.6	58.5	52.5	46.5	39.5	33.9	27.6
1500	77	84.6	3.4	44.6	37.2	29.7	-	-	-	80.1	3.8	42.6	35.3	28.0	-	-	-
	72	76.3	3.4	52.7	45.1	37.4	29.8	-	-	72.0	3.7	50.7	43.1	35.6	28.1	-	-
	67	67.9	3.3	60.8	53.0	45.1	37.6	29.8	-	63.9	3.7	58.8	51.0	43.3	35.7	28.0	-
	62	63.9	3.3	63.5	58.1	52.8	44.0	37.5	29.9	61.4	3.6	60.7	55.8	50.9	42.6	35.4	27.6
1750	77	84.6	3.4	47.8	38.3	28.8	-	-	-	79.4	3.8	46.0	36.5	26.9	-	-	-
	72	77.0	3.4	55.9	47.1	38.3	29.6	-	-	72.5	3.7	53.8	45.1	36.4	27.7	-	-
	67	69.4	3.3	64.0	55.9	47.8	39.0	29.9	-	65.5	3.7	61.5	53.7	45.9	37.0	27.9	-
	62	66.5	3.3	66.0	61.6	57.3	47.3	39.0	29.9	63.6	3.7	62.9	59.1	55.4	45.7	36.8	27.5
2000	77	84.6	3.4	50.9	39.4	28.0	-	-	-	78.7	3.8	49.5	37.7	25.9	-	-	-
	72	77.7	3.4	59.1	49.2	39.3	29.3	-	-	72.9	3.7	56.9	47.1	37.2	27.4	-	-
	67	70.9	3.3	67.3	58.9	50.6	40.3	30.0	-	67.1	3.7	64.3	56.4	48.5	38.2	27.9	-
	62	69.2	3.3	68.5	65.2	61.9	50.6	40.5	29.9	65.8	3.7	65.1	62.5	59.8	48.8	38.2	27.4
2250	77	84.6	3.4	50.9	39.4	28.0	-	-	-	78.7	3.8	49.5	37.7	25.9	-	-	-
	72	77.7	3.4	59.1	49.2	39.3	29.3	-	-	72.9	3.7	56.9	47.1	37.2	27.4	-	-
	67	70.9	3.3	67.3	58.9	50.6	40.3	30.0	-	67.1	3.7	64.3	56.4	48.5	38.2	27.9	-
	62	69.2	3.3	68.5	65.2	61.9	50.6	40.5	29.9	65.8	3.7	65.1	62.5	59.8	48.8	38.2	27.4
2500	77	84.6	3.4	50.9	39.4	28.0	-	-	-	78.7	3.8	49.5	37.7	25.9	-	-	-
	72	77.7	3.4	59.1	49.2	39.3	29.3	-	-	72.9	3.7	56.9	47.1	37.2	27.4	-	-
	67	70.9	3.3	67.3	58.9	50.6	40.3	30.0	-	67.1	3.7	64.3	56.4	48.5	38.2	27.9	-
	62	69.2	3.3	68.5	65.2	61.9	50.6	40.5	29.9	65.8	3.7	65.1	62.5	59.8	48.8	38.2	27.4
1250	77	77.0	4.2	36.8	32.1	27.3	-	-	-	70.3	4.8	34.7	29.7	24.6	-	-	-
	72	67.6	4.1	45.6	39.4	33.1	26.9	-	-	62.8	4.7	43.5	37.1	30.7	24.4	-	-
	67	58.2	4.1	54.3	46.6	38.9	32.6	26.2	-	55.3	4.6	52.2	44.5	36.8	30.4	24.0	-
	62	56.9	4.0	56.0	50.4	44.7	38.3	31.8	25.3	53.6	4.6	52.5	47.7	42.9	36.5	30.0	23.5
1500	77	75.6	4.2	40.6	33.4	26.2	-	-	-	69.0	4.8	38.6	31.0	23.5	-	-	-
	72	67.8	4.1	48.6	41.2	33.8	26.4	-	-	62.9	4.7	46.4	38.9	31.4	23.9	-	-
	67	59.9	4.1	56.7	49.1	41.5	33.8	26.1	-	56.8	4.6	54.2	46.7	39.3	31.6	23.8	-
	62	58.8	4.0	57.9	53.5	49.1	41.1	33.2	25.2	55.3	4.6	54.3	50.8	47.3	39.3	31.3	23.3
1750	77	74.2	4.2	44.3	34.7	25.0	-	-	-	67.7	4.7	42.4	32.4	22.3	-	-	-
	72	67.9	4.1	51.7	43.1	34.5	25.9	-	-	63.0	4.7	49.3	40.7	32.1	23.5	-	-
	67	61.6	4.1	59.1	51.5	44.0	35.0	26.0	-	58.3	4.6	56.1	49.0	41.8	32.7	23.7	-
	62	60.6	4.0	59.8	56.6	53.5	44.0	34.6	25.1	57.0	4.6	56.0	53.8	51.6	42.0	32.5	23.0
2000	77	72.8	4.1	48.1	36.0	23.9	-	-	-	66.5	4.7	46.2	33.7	21.2	-	-	-
	72	68.1	4.1	54.8	45.0	35.2	25.4	-	-	63.1	4.7	52.2	42.4	32.7	23.0	-	-
	67	63.3	4.1	61.4	54.0	46.5	36.2	25.8	-	59.8	4.6	58.1	51.2	44.3	33.9	23.5	-
	62	62.4	4.1	61.7	59.8	57.8	46.9	36.0	25.0	58.7	4.6	57.8	56.8	55.9	44.8	33.7	22.7
2250	77	72.8	4.1	48.1	36.0	23.9	-	-	-	66.5	4.7	46.2	33.7	21.2	-	-	-
	72	68.1	4.1	54.8	45.0	35.2	25.4	-	-	63.1	4.7	52.2	42.4	32.7	23.0	-	-
	67	63.3	4.1	61.4	54.0	46.5	36.2	25.8	-	59.8	4.6	58.1	51.2	44.3	33.9	23.5	-
	62	62.4	4.1	61.7	59.8	57.8	46.9	36.0	25.0	58.7	4.6	57.8	56.8	55.9	44.8	33.7	22.7
2500	77	72.8	4.1	48.1	36.0	23.9	-	-	-	66.5	4.7	46.2	33.7	21.2	-	-	-
	72	68.1	4.1	54.8	45.0	35.2	25.4	-	-	63.1	4.7	52.2	42.4	32.7	23.0	-	-
	67	63.3	4.1	61.4	54.0	46.5	36.2	25.8	-	59.8	4.6	58.1	51.2	44.3	33.9	23.5	-
	62	62.4	4.1	61.7	59.8	57.8	46.9	36.0	25.0	58.7	4.6	57.8	56.8	55.9	44.8	33.7	22.7
1250	77	68.4	4.1	60.9	48.7	36.6	24.4	-	-	63.4	4.6	57.9	46.0	34.1	22.1	-	-
	72	66.8	4.1	66.1	58.9	51.6	38.5	25.5	-	62.7	4.6	61.9	55.6	49.3	36.2	23.2	-
	67	66.1	4.1	65.5	65.5	65.5	52.6	38.7	24.8	62.1	4.6	61.3	61.3	61.3	50.4	36.2	22.1
	62	65.4	4.1	64.8	64.8	64.8	64.8	51.9	37.2	61.5	4.6	60.7	60.7	60.7	60.7	49.2	34.0

## ZV-A5 High Speed Compressor (5.0 Ton) (Continued)

Air on Evaporator Coil		Temperature of Air on Condenser Coil															
		Total Capacity <sup>1</sup> (MBh)	Total Input (kW) <sup>2</sup>	Sensible Capacity (MBh)						Total Capacity <sup>1</sup> (MBh)	Total Input (kW) <sup>2</sup>	Sensible Capacity (MBh)					
Return Dry Bulb (°F)						Return Dry Bulb (°F)											
90	85			80	75	70	65	90	85			80	75	70	65		
		115°F									125°F						
1250	77	63.5	5.4	32.6	27.3	21.9	-	-	-	56.7	6.1	30.5	24.9	19.2	-	-	-
	72	57.9	5.3	41.4	34.9	28.3	21.8	-	-	53.0	5.9	39.3	32.6	25.9	19.3	-	-
	67	52.3	5.2	50.1	42.4	34.7	28.3	21.8	-	49.4	5.8	48.0	40.3	32.6	26.1	19.5	-
	62	50.2	5.1	49.0	45.1	41.1	34.7	28.2	21.8	46.8	5.7	45.5	42.4	39.4	32.9	26.5	20.0
1500	77	62.3	5.4	36.6	28.7	20.8	-	-	-	55.7	6.0	34.5	26.3	18.0	-	-	-
	72	58.0	5.3	44.1	36.5	29.0	21.4	-	-	53.1	5.9	41.8	34.2	26.6	18.9	-	-
	67	53.6	5.2	51.6	44.4	37.2	29.4	21.6	-	50.5	5.8	49.1	42.1	35.1	27.2	19.3	-
	62	51.8	5.1	50.6	48.0	45.4	37.4	29.3	21.3	48.3	5.7	47.0	45.3	43.6	35.5	27.4	19.3
	57	50.0	5.0	49.6	49.6	49.6	45.4	37.1	28.8	46.2	5.6	44.8	44.8	44.8	43.8	35.5	27.2
1750	77	61.2	5.3	40.5	30.0	19.6	-	-	-	54.7	5.9	38.6	27.7	16.9	-	-	-
	72	58.1	5.2	46.8	38.2	29.6	21.0	-	-	53.2	5.8	44.4	35.8	27.2	18.5	-	-
	67	54.9	5.2	53.2	46.4	39.6	30.5	21.4	-	51.5	5.7	50.2	43.8	37.5	28.3	19.1	-
	62	53.4	5.1	52.3	51.0	49.7	40.0	30.4	20.8	49.8	5.7	48.5	48.1	47.8	38.1	28.4	18.6
	57	51.9	5.1	51.3	51.3	51.3	49.6	39.4	29.3	48.0	5.6	46.7	46.7	46.7	46.7	37.6	27.3
2000	77	60.1	5.3	44.4	31.4	18.4	-	-	-	53.7	5.8	42.6	29.1	15.7	-	-	-
	72	58.2	5.2	49.6	39.9	30.3	20.6	-	-	53.3	5.7	47.0	37.4	27.8	18.2	-	-
	67	56.2	5.1	54.7	48.4	42.1	31.7	21.2	-	52.6	5.7	51.3	45.6	39.9	29.4	18.9	-
	62	55.0	5.1	53.9	53.9	53.9	42.7	31.5	20.3	51.2	5.6	50.0	50.0	50.0	40.6	29.3	17.9
	57	53.8	5.1	53.1	53.1	53.1	53.1	41.8	29.8	49.9	5.6	48.6	48.6	48.6	48.6	39.6	27.4
2250	72	58.3	5.2	52.3	41.6	30.9	20.2	-	-	53.3	5.7	49.5	38.9	28.4	17.8	-	-
	67	57.5	5.1	56.2	50.4	44.5	32.8	21.1	-	53.7	5.6	52.4	47.4	42.3	30.5	18.7	-
	62	56.6	5.1	55.5	55.5	55.5	45.4	32.6	19.8	52.7	5.6	51.5	51.5	51.5	43.2	30.2	17.2
	57	55.7	5.1	54.8	54.8	54.8	54.8	44.1	30.3	51.8	5.6	50.5	50.5	50.5	50.5	41.7	27.5
2500	72	58.4	5.1	55.0	43.3	31.5	19.8	-	-	53.4	5.6	-	40.5	29.0	17.5	-	-
	67	58.7	5.1	57.8	52.4	47.0	33.9	20.9	-	54.7	5.6	-	49.1	44.7	31.6	18.6	-
	62	58.1	5.1	57.2	57.2	57.2	48.1	33.7	19.3	54.2	5.6	-	53.0	53.0	45.8	31.2	16.5
	57	57.5	5.1	56.6	56.6	56.6	56.6	46.5	30.8	53.6	5.6	-	52.4	52.4	52.4	43.8	27.6

1. These capacities are gross ratings. For net capacity, deduct air blower motor, MBh = 3.415 x kW. Refer to the appropriate Blower Performance Table for the kW of the supply air blower motor.
2. These ratings include the condenser fan motors (total 1 kW) and the compressor motors but not the supply air blower motor.

ZV-A5 Low Speed Compressor (5.0 Ton)

Air on Evaporator Coil		Temperature of Air on Condenser Coil															
CFM	WB (°F)	Total Capacity <sup>1</sup> (MBh)	Total Input (kW) <sup>2</sup>	Sensible Capacity (MBh)						Total Capacity <sup>1</sup> (MBh)	Total Input (kW) <sup>2</sup>	Sensible Capacity (MBh)					
				Return Dry Bulb (°F)								Return Dry Bulb (°F)					
				90	85	80	75	70	65			90	85	80	75	70	65
		75°F								85°F							
1250	77	62.4	2.0	33.2	27.2	21.2	-	-	-	58.7	2.4	34.6	27.8	21.0	-	-	-
	72	56.5	2.1	41.8	35.0	28.3	21.5	-	-	53.5	2.4	41.2	34.2	27.3	20.4	-	-
	67	50.7	2.1	50.3	42.8	35.3	27.9	21.8	-	48.3	2.4	47.8	40.7	33.7	26.7	20.4	-
	62	49.2	2.1	48.8	45.8	42.9	31.7	28.9	22.1	47.2	2.4	46.7	43.5	40.3	31.7	27.3	20.9
1500	77	62.4	2.0	38.2	29.6	21.0	-	-	-	58.5	2.4	38.6	29.4	20.2	-	-	-
	72	57.3	2.0	45.1	37.4	29.6	21.9	-	-	54.1	2.4	43.9	36.1	28.3	20.6	-	-
	67	52.3	2.1	52.0	45.1	38.3	29.7	22.3	-	49.7	2.4	49.2	42.9	36.5	28.4	20.7	-
	62	51.1	2.1	50.7	48.8	46.9	35.5	30.4	22.1	48.8	2.4	48.3	46.5	44.7	35.1	28.7	20.7
1750	77	62.4	2.0	43.2	32.0	20.8	-	-	-	58.3	2.4	42.6	31.0	19.3	-	-	-
	72	58.1	2.0	48.4	39.7	31.0	22.3	-	-	54.7	2.4	46.6	38.0	29.4	20.7	-	-
	67	53.9	2.1	53.6	47.4	41.2	31.6	22.8	-	51.1	2.4	50.6	45.0	39.4	30.0	21.1	-
	62	53.0	2.1	52.7	51.8	50.9	39.3	31.9	22.2	50.4	2.4	50.0	49.6	49.1	38.5	30.1	20.4
2000	77	62.4	2.0	48.1	34.4	20.7	-	-	-	58.1	2.4	46.6	32.6	18.5	-	-	-
	72	58.9	2.0	51.7	42.0	32.4	22.7	-	-	55.3	2.4	49.3	39.9	30.4	20.9	-	-
	67	55.5	2.0	55.3	49.7	44.1	33.4	23.3	-	52.5	2.4	52.1	47.2	42.2	31.7	21.4	-
	62	54.9	2.0	54.6	54.6	54.6	43.1	33.4	22.2	52.0	2.4	51.6	51.6	51.6	42.0	31.4	20.1
2250	72	59.7	2.0	55.0	44.4	33.8	23.2	-	-	55.9	2.4	52.1	41.7	31.4	21.1	-	-
	67	57.1	2.0	56.9	52.0	47.1	35.3	23.8	-	53.9	2.4	53.5	49.3	45.1	33.4	21.8	-
	62	56.7	2.0	56.6	56.6	56.6	46.9	35.0	22.3	53.6	2.4	53.3	53.3	53.3	45.4	32.8	19.9
	57	56.4	2.0	56.2	56.2	56.2	56.2	46.2	32.5	53.4	2.4	53.0	53.0	53.0	53.0	43.9	29.6
2500	72	60.5	2.0	-	46.7	35.1	23.6	-	-	56.4	2.4	-	43.6	32.4	21.2	-	-
	67	58.7	2.0	-	54.3	50.0	37.1	24.2	-	55.3	2.3	-	51.4	47.9	35.0	22.1	-
	62	58.6	2.0	-	58.5	58.5	50.7	36.5	22.3	55.2	2.4	-	54.9	54.9	48.8	34.2	19.6
	57	58.6	2.0	-	58.5	58.5	58.5	48.8	33.3	55.2	2.4	-	54.9	54.9	54.9	46.3	29.9
		95°F								105°F							
1250	77	55.1	2.8	35.9	28.3	20.7	-	-	-	50.1	3.3	36.1	27.6	19.2	-	-	-
	72	50.5	2.8	40.5	33.5	26.4	19.3	-	-	46.6	3.3	39.1	32.0	24.8	17.6	-	-
	67	45.9	2.8	45.2	38.6	32.0	25.5	19.0	-	43.1	3.2	42.2	36.3	30.4	23.8	17.1	-
	62	45.3	2.7	44.6	41.1	37.7	31.7	25.7	19.8	42.7	3.2	41.8	38.9	36.1	29.9	23.7	17.5
1500	77	54.7	2.8	39.0	29.1	19.3	-	-	-	49.9	3.3	38.4	27.9	17.3	-	-	-
	72	50.9	2.8	42.7	34.9	27.0	19.2	-	-	47.0	3.2	40.8	33.0	25.1	17.3	-	-
	67	47.1	2.8	46.4	40.6	34.8	27.0	19.2	-	44.1	3.2	43.3	38.1	33.0	25.1	17.2	-
	62	46.6	2.7	45.9	44.2	42.5	34.8	27.0	19.2	43.8	3.2	43.0	41.9	40.8	32.9	25.0	17.1
1750	77	54.2	2.7	42.0	29.9	17.9	-	-	-	49.7	3.2	40.7	28.1	15.5	-	-	-
	72	51.3	2.7	44.8	36.3	27.7	19.1	-	-	47.4	3.2	42.5	34.0	25.5	17.0	-	-
	67	48.3	2.7	47.7	42.6	37.6	28.5	19.4	-	45.1	3.2	44.3	39.9	35.5	26.4	17.4	-
	62	47.9	2.7	47.3	47.3	47.3	37.8	28.2	18.6	45.0	3.2	44.2	44.2	44.2	35.9	26.3	16.7
2000	77	53.8	2.7	45.1	30.7	16.4	-	-	-	49.4	3.2	43.0	28.3	13.6	-	-	-
	72	51.6	2.7	47.0	37.7	28.4	19.1	-	-	47.8	3.2	44.2	35.0	25.8	16.6	-	-
	67	49.5	2.7	48.9	44.6	40.3	30.0	19.6	-	46.2	3.2	45.4	41.7	38.0	27.8	17.5	-
	62	49.2	2.7	48.6	48.6	48.6	40.9	29.4	18.0	46.1	3.2	45.3	45.3	45.3	38.9	27.6	16.3
2250	72	52.0	2.7	49.1	39.1	29.0	19.0	-	-	48.3	3.2	45.9	36.0	26.2	16.3	-	-
	67	50.7	2.7	50.1	46.6	43.1	31.5	19.8	-	47.2	3.2	46.5	43.5	40.5	29.1	17.7	-
	62	50.5	2.7	50.0	50.0	50.0	43.9	30.7	17.4	47.3	3.2	46.5	46.5	46.5	41.9	28.9	15.9
	57	50.4	2.7	49.8	49.8	49.8	49.8	41.5	26.7	47.3	3.2	46.6	46.6	46.6	46.6	40.1	25.5
2500	72	52.4	2.7	-	40.5	29.7	18.9	-	-	48.7	3.2	-	37.0	26.5	16.0	-	-
	67	51.9	2.7	-	48.6	45.9	32.9	20.0	-	48.3	3.1	-	45.3	43.1	30.4	17.8	-
	62	51.8	2.7	-	51.3	51.3	47.0	31.9	16.8	48.4	3.2	-	47.7	47.7	44.9	30.2	15.5
	57	51.8	2.7	-	51.3	51.3	51.3	43.8	26.6	48.6	3.2	-	47.9	47.9	47.9	42.6	25.7

## ZV-A5 Low Speed Compressor (5.0 Ton) (Continued)

Air on Evaporator Coil		Temperature of Air on Condenser Coil															
CFM	WB (°F)	Total Capacity <sup>1</sup> (MBh)	Total Input (kW) <sup>2</sup>	Sensible Capacity (MBh)						Total Capacity <sup>1</sup> (MBh)	Total Input (kW) <sup>2</sup>	Sensible Capacity (MBh)					
				Return Dry Bulb (°F)								Return Dry Bulb (°F)					
				90	85	80	75	70	65			90	85	80	75	70	65
				115°F						125°F							
1250	77	45.1	3.8	-	27.0	17.6	-	-	-	40.1	4.3	-	26.3	16.1	-	-	-
	72	42.6	3.7	-	30.5	23.2	16.0	-	-	38.7	4.2	-	29.0	21.6	14.3	-	-
	67	40.2	3.7	-	34.0	28.8	22.0	15.2	-	37.4	4.1	-	31.7	27.2	20.3	13.3	-
	62	40.0	3.7	-	36.7	34.4	28.1	21.7	15.3	37.4	4.2	-	34.5	32.8	26.2	19.6	13.0
1500	77	45.1	3.8	-	26.6	15.4	-	-	-	40.3	4.3	-	25.4	13.4	-	-	-
	72	43.1	3.7	-	31.1	23.2	15.4	-	-	39.2	4.2	-	29.2	21.3	13.5	-	-
	67	41.1	3.7	-	35.6	31.1	23.2	15.3	-	38.1	4.1	-	33.1	29.3	21.3	13.3	-
	62	41.0	3.7	-	39.5	39.0	31.0	23.0	15.0	38.2	4.2	-	37.0	37.0	29.1	21.1	13.0
	57	40.9	3.7	-	39.9	39.9	38.8	30.8	22.7	38.4	4.2	-	37.2	37.2	37.0	28.8	20.6
1750	77	45.1	3.7	39.4	26.3	13.1	-	-	-	40.5	4.2	38.1	24.4	10.7	-	-	-
	72	43.6	3.7	40.2	31.7	23.3	14.8	-	-	39.7	4.2	37.9	29.5	21.0	12.6	-	-
	67	42.0	3.7	41.0	37.2	33.4	24.4	15.4	-	38.8	4.1	37.7	34.5	31.3	22.3	13.3	-
	62	42.0	3.7	41.0	41.0	41.0	34.0	24.4	14.8	39.1	4.1	37.9	37.9	37.9	32.1	22.5	12.9
	57	42.1	3.7	41.1	41.1	41.1	41.1	33.4	23.3	39.3	4.2	38.1	38.1	38.1	38.1	31.6	21.5
2000	77	45.1	3.7	41.0	25.9	10.9	-	-	-	40.8	4.2	38.9	23.5	8.1	-	-	-
	72	44.0	3.7	41.4	32.4	23.3	14.2	-	-	40.3	4.2	38.7	29.7	20.7	11.8	-	-
	67	42.9	3.6	41.9	38.8	35.7	25.6	15.4	-	39.6	4.1	38.4	35.9	33.4	23.4	13.4	-
	62	43.0	3.7	42.1	42.1	42.1	36.9	25.8	14.6	39.9	4.1	38.8	38.8	38.8	35.0	23.9	12.8
	57	43.2	3.7	42.2	42.2	42.2	42.2	36.1	23.8	40.3	4.1	39.1	39.1	39.1	39.1	34.5	22.3
2250	72	44.5	3.7	42.7	33.0	23.3	13.6	-	-	40.8	4.1	39.4	29.9	20.4	10.9	-	-
	67	43.8	3.6	42.8	40.4	38.0	26.8	15.5	-	40.3	4.1	39.2	37.3	35.4	24.4	13.4	-
	62	44.0	3.6	43.1	43.1	43.1	39.9	27.1	14.3	40.8	4.1	39.6	39.6	39.6	37.9	25.3	12.8
	57	44.3	3.6	43.3	43.3	43.3	43.3	38.7	24.4	41.2	4.1	40.1	40.1	40.1	40.1	37.3	23.2
2500	72	45.0	3.6	-	33.6	23.3	13.0	-	-	41.3	4.1	-	-	-	-	-	-
	67	44.6	3.6	-	42.0	40.3	27.9	15.6	-	41.0	4.1	-	-	-	-	-	-
	62	45.0	3.6	-	44.1	44.1	42.9	28.5	14.1	41.6	4.1	-	-	-	-	-	-
	57	45.4	3.6	-	44.5	44.5	44.5	41.3	24.9	42.2	4.1	-	-	-	-	-	-

1. These capacities are gross ratings. For net capacity, deduct air blower motor, MBh = 3.415 x kW. Refer to the appropriate Blower Performance Table for the kW of the supply air blower motor.
2. These ratings include the condenser fan motors (total 1 kW) and the compressor motors but not the supply air blower motor.

**Drive Selection**

1. Determine side or bottom supply duct Application.
2. Determine desired airflow.
3. Calculate or measure the amount of external static pressure.
  - Add or deduct any additional static resistance from “Additional Static Resistance Table”.
4. Using the operating point determined from steps 1, 2 & 3, locate this point on the appropriate supply air blower performance table. (Linear interpolation may be necessary.)
5. Noting the RPM and BHP from step 4, locate the appropriate motor and, or drive on the RPM selection table.
6. Review the BHP compared to the motor options available. Select the appropriate motor and, or drive.
7. Review the RPM range for the motor options available. Select the appropriate drive if multiple drives are available for the chosen motor.
8. Determine turns open to obtain the desired operation point.

**Example**

1. 2600 CFM
2. 1.6 iwg
3. Using the supply air blower performance table below, the following data point was located: 1268 RPM & 1.95 BHP.
4. Using the RPM selection table below, Size X and Model Y is found.
5. 1.95 BHP exceeds the maximum continuous BHP rating of the 1.5 HP motor. The 2 HP motor is required.
6. 1268 RPM is within the range of the 2 HP drives.
7. Using the 2 HP motor and drive, .5 turns open will achieve 1268 RPM.

**Airflow Performance**

**Example Supply Air Blower Performance**

Air Flow (CFM)	Available External Static Pressure - IWG																			
	0.2		0.4		0.6		0.8		1.0		1.2		1.4		1.6		1.8		2.0	
	RPM	BHP	RPM	BHP	RPM	BHP	RPM	BHP	RPM	BHP	RPM	BHP	RPM	BHP	RPM	BHP	RPM	BHP	RPM	BHP
	1.5 HP & Field Supplied Drive						Standard 1.5 HP & Drive						Alternate 2 HP & Drive							
2200	804	0.50	866	0.71	925	0.90	982	1.06	1038	1.21	1092	1.35	1147	1.48	1203	1.61	1259	1.73	1317	1.87
2400	835	0.66	897	0.87	956	1.06	1013	1.22	1069	1.37	1124	1.51	1178	1.64	1234	1.77	1290	1.90	1348	2.03
2600	869	0.84	931	1.05	990	1.24	1047	1.40	1103	1.55	1158	1.69	1212	1.82	1268	1.95	1324	2.07	1382	2.21
2800	906	1.03	968	1.25	1027	1.43	1084	1.60	1139	1.75	1194	1.89	1249	2.02	1304	2.14	1361	2.27	-	-

**Example RPM Selection**

Size (Tons)	Model	Airflow Option	HP	Max BHP	Motor Sheave	Blower Sheave	6 Turns Open	5 Turns Open	4 Turns Open	3 Turns Open	2 Turns Open	1 Turn Open	Fully Closed
X	Y	Std.	1.5	1.73	1VM50	AK74	N/A	897	945	991	1035	1079	1126
		H. Static	2	2.30	1VM50	AK64	N/A	1039	1094	1150	1207	1256	1308

**Example Additional Static Resistance**

Size (Tons)	Model	CFM	Cooling Only	Economizer	4" Pleated Filter	Electric Heat kW					
						3	6	9	15	20	24
X	Y	900	0.05	-0.05	0.01	0.00	0.00	0.00	0.01	0.01	0.01
		1000	0.05	-0.03	0.02	0.00	0.00	0.00	0.02	0.02	0.02
		1100	0.04	-0.02	0.03	0.01	0.01	0.01	0.02	0.02	0.02
		1200	0.04	0.00	0.04	0.01	0.01	0.01	0.02	0.02	0.02
		1300	0.03	0.01	0.05	0.01	0.01	0.01	0.03	0.03	0.03

### Altitude and Temperature Correction for CFM, Static Pressure and Power.

The information below should be used to assist in application of product when being applied at altitudes at or exceeding 1000 feet above sea level.

The air flow rates listed in the standard blower performance tables are based on standard air at sea level. As the altitude or temperature increases, the density of air decreases. In order to use the indoor blower tables for high altitude applications, certain corrections are necessary.

A centrifugal fan is a "constant volume" device. This means that, if the rpm remains constant, the CFM delivered is the same regardless of the density of the air. However, since the air at high altitude is less dense, less static pressure will be generated and less power will be required than a similar application at sea level. Air density correction factors are shown in Table 14 and Figure 27.

### Altitude/Temperature Correction Factors

Air Temp.	Altitude (Ft.)										
	0	1000	2000	3000	4000	5000	6000	7000	8000	9000	10000
40	1.060	1.022	0.986	0.950	0.916	0.882	0.849	0.818	0.788	0.758	0.729
50	1.039	1.002	0.966	0.931	0.898	0.864	0.832	0.802	0.772	0.743	0.715
60	1.019	0.982	0.948	0.913	0.880	0.848	0.816	0.787	0.757	0.729	0.701
70	1.000	0.964	0.930	0.896	0.864	0.832	0.801	0.772	0.743	0.715	0.688
80	0.982	0.947	0.913	0.880	0.848	0.817	0.787	0.758	0.730	0.702	0.676
90	0.964	0.929	0.897	0.864	0.833	0.802	0.772	0.744	0.716	0.689	0.663
100	0.946	0.912	0.880	0.848	0.817	0.787	0.758	0.730	0.703	0.676	0.651

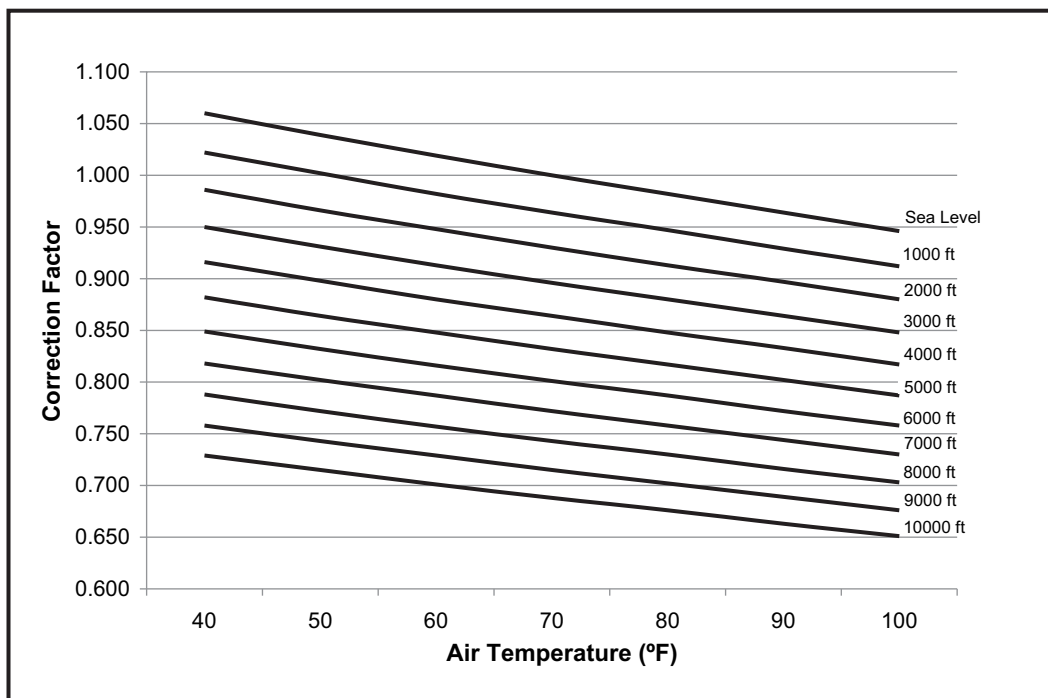

The examples below will assist in determining the airflow performance of the product at altitude.

**Example 1:** What are the corrected CFM, static pressure, and BHP at an elevation of 5,000 ft. if the blower performance data is 6,000 CFM, 1.5 IWC and 4.0 BHP?

**Solution:** At an elevation of 5,000 ft. the indoor blower will still deliver 6,000 CFM if the rpm is unchanged. However, Table 13 must be used to determine the static pressure and BHP. Since no temperature data is given, we will assume an air temperature of 70°F. Table 15 shows the correction factor to be 0.832.

$$\text{Corrected static pressure} = 1.5 \times 0.832 = 1.248 \text{ IWC}$$

$$\text{Corrected BHP} = 4.0 \times 0.832 = 3.328$$

**Example 2:** A system, located at 5,000 feet of elevation, is to deliver 6,000 CFM at a static pressure of 1.5". Use the unit blower tables to select the blower speed and the BHP requirement.

**Solution:** As in the example above, no temperature information is given so 70°F is assumed.



The 1.5" static pressure given is at an elevation of 5,000 ft. The first step is to convert this static pressure to equivalent sea level conditions.

$$\text{Sea level static pressure} = 1.5 / .832 = 1.80"$$

Enter the blower table at 6000 sCFM and static pressure of 1.8". The rpm listed will be the same rpm needed at 5,000 ft.

Suppose that the corresponding BHP listed in the table is 3.2. This value must be corrected for elevation.

$$\text{BHP at 5,000 ft.} = 3.2 \times .832 = 2.66$$

**Indoor Blower Specifications**

Size (Tons)	Model	Airflow Option	Motor					Motor Sheave			Blower Sheave			Belt
			HP	RPM	Eff.	SF	Frame	Datum Dia. (in.)	Bore (in.)	Model	Datum Dia. (in.)	Bore (in.)	Model	
-A3 (3)	ZV	Std.	1-1/2	1725	0.86	1.15	56	2.4 - 3.4	7/8	1VL40	7.5	1	AK79	A47
		H. Static	1-1/2	1725	0.86	1.15	56	2.4 - 3.4	7/8	1VL40	5.7	1	AK61	A45
-A4 (4)	ZV	Std.	1-1/2	1725	0.86	1.15	56	1.9 - 2.9	7/8	1VL34	6	1	AK64	A47
		H. Static	1-1/2	1725	0.86	1.15	56	2.8 - 3.8	7/8	1VL44	6.5	1	AK69	A47
-A5 (5)	ZV	Std.	1-1/2	1725	0.86	1.15	56	2.4 - 3.4	7/8	1VL40	5.7	1	AK61	A45
		H. Static	2	1725	0.86	1.15	56	3.4 - 4.4	7/8	1VM50	6	1	AK64	A47

**Power Exhaust Specifications**

Model	Voltage	Motor			Motor			Fuse Size	CFM @ 0.1 ESP
		HP	RPM <sup>1</sup>	QTY	LRA	FLA	MCA		
2PE04703225	208/230-1-60	3/4	1075	1	7.8	5	6.3	10	3800
2PE04703246	460-1-60	3/4	1075	1	3.4	2.2	2.8	5	3800
2PE04703258	575-1-60	3/4	1050	1	2.9	1.5	1.9	4	3800

1. Motors are multi-tapped and factory wired for high speed.

**RPM Selection**

Size (Tons)	Model	Airflow Option	HP	Max BHP	Motor Sheave	Blower Sheave	6 Turns Open	5 Turns Open	4 Turns Open	3 Turns Open	2 Turns Open	1 Turn Open	Fully Closed
-A3 (3)	ZV	Field Supplied	1.5	1.5	1VL34	AK79	N/A	465	512	557	606	651	695
		Std.	1.5	1.5	1VL40	AK79	N/A	612	661	707	752	799	844
		H. Static	1.5	1.5	1VL40	AK61	N/A	782	846	906	968	1022	1085
		Field Supplied	1.5	1.5	1VL40	AK54	N/A	896	960	1030	1090	1166	1238
-A4 (4)	ZV	Std.	1.5	1.5	1VL34	AK64	N/A	576	631	688	747	800	859
		H. Static	1.5	1.5	1VL44	AK69	N/A	792	844	892	944	996	1045
		Field Supplied	1.5	1.5	1VL44	AK59	N/A	915	989	1050	1113	1173	1238
-A5 (5)	ZV	Field Supplied	1.5	1.5	1VL40	AK79	N/A	609	656	703	746	792	839
		Std.	1.5	1.5	1VL40	AK61	N/A	782	846	906	968	1022	1085
		Field Supplied	2	2	1VL40	AK54	N/A	896	960	1030	1090	1166	1238
		H. Static	2	2	1VM50	AK64	N/A	1022	1079	1135	1190	1246	1297

## Additional Static Resistance

Size (Tons)	Model	CFM	Cooling Only <sup>1</sup>	Economizer <sup>2 3</sup>	4" Pleated Filter <sup>2</sup>	Electric Heat kW <sup>2</sup>					
						3	6	9	15	20	24
-A3 (3)	ZV	900	0.05	-0.05	0.01	0.00	0.00	0.00	0.01	0.01	0.01
		1000	0.05	-0.03	0.02	0.00	0.00	0.00	0.02	0.02	0.02
		1100	0.04	-0.02	0.03	0.01	0.01	0.01	0.02	0.02	0.02
		1200	0.04	0.00	0.04	0.01	0.01	0.01	0.02	0.02	0.02
		1300	0.03	0.01	0.05	0.01	0.01	0.01	0.03	0.03	0.03
		1400	0.03	0.03	0.07	0.02	0.02	0.02	0.03	0.03	0.03
-A4 (4) -A5 (5)	ZV	1200	-0.01	0.10	0.05	0.01	0.01	0.01	0.02	0.02	0.02
		1300	-0.01	0.11	0.06	0.01	0.01	0.01	0.03	0.03	0.03
		1400	-0.01	0.12	0.06	0.02	0.02	0.02	0.03	0.03	0.03
		1500	-0.01	0.13	0.07	0.02	0.02	0.02	0.04	0.04	0.04
		1600	-0.01	0.14	0.08	0.02	0.02	0.02	0.04	0.04	0.04
		1700	-0.01	0.15	0.08	0.03	0.03	0.03	0.05	0.05	0.05
		1800	-0.02	0.16	0.09	0.03	0.03	0.03	0.05	0.05	0.05
		1900	-0.02	0.17	0.10	0.04	0.04	0.04	0.06	0.06	0.06
		2000	-0.02	0.18	0.10	0.04	0.04	0.04	0.07	0.07	0.07
		2100	-0.03	0.19	0.11	0.05	0.05	0.05	0.07	0.07	0.07
		2200	-0.03	0.20	0.12	0.06	0.06	0.06	0.08	0.08	0.08
		2300	-0.04	0.21	0.12	0.06	0.06	0.06	0.09	0.09	0.09
		2400	-0.04	0.22	0.13	0.07	0.07	0.07	0.10	0.10	0.10
		2500	-0.05	0.23	0.14	0.08	0.08	0.08	0.11	0.11	0.11

1. Add these values to the available static resistance in the respective Blower Performance Tables.
2. Deduct these values from the available external static pressure shown in the respective Blower Performance Tables.
3. The pressure drop through the economizer is greater for 100% outdoor air than for 100% return air. If the resistance of the return air duct is less than 0.25 IWG, the unit will deliver less CFM during full economizer operation.

## Gas Heat Minimum Supply Air

Size (Tons)	Model	Heat Size	Supply Air (CFM)	
			Heating	
			Min	Max
-A3 (3)	ZV	A06 / N06	890	2220
		A08 / N08	915	2370
		A11 / N11	1130	1800
-A4 (4)	ZV	A06 / N06	890	2220
		A08 / N08	915	2370
		A11 / N11	1290	2250
-A5 (5)	ZV	A08 / N08	915	2370
		A11 / N11	1380	2570
		A16 / N16	1580	2630

## Electric Heat Minimum Supply Air

## 3 thru 5 Tons

Size (Tons)	Model	Voltage	Minimum Supply Air (CFM)					
			Heater kW					
			3	6	9	15	20	24
-A3 (3)	ZV	208/230-3-60	960	960	1020	1020	-	-
		460-3-60	980	960	960	960	-	-
		600-3-60	-	-	960	960	-	-
-A4 (4)	ZV	208/230-3-60	-	1280	1420	1420	1420	-
		460-3-60	-	1400	1400	1400	1400	-
		600-3-60	-	-	1400	1400	1400	-
-A5 (5)	ZV	208/230-3-60	-	1600	1600	1600	1600	1600
		460-3-60	-	1600	1600	1600	1600	1600
		600-3-60	-	-	1600	1600	1600	1600

## Airflow Performance

### ZV-A3 thru -A5 Side Duct Application

#### ZV-A3 (3.0 Ton) Side Duct

Air Flow (CFM)	Available External Static Pressure - IWG <sup>1</sup>																			
	0.2		0.4		0.6		0.8		1.0		1.2		1.4		1.6		1.8		2.0	
	RPM	BHP	RPM	BHP	RPM	BHP	RPM	BHP	RPM	BHP	RPM	BHP	RPM	BHP	RPM	BHP	RPM	BHP	RPM	BHP
	FS <sup>4</sup>				Standard 1.5 Hp & Drive						High Static 1.5 Hp & Drive				FS <sup>4</sup>					
900	468	0.24	563	0.27	652	0.36	736	0.46	814	0.56	887	0.67	955	0.76	1017	0.87	1074	1.01	1126	1.09
1000	479	0.25	578	0.29	670	0.38	756	0.47	837	0.57	911	0.68	979	0.78	1041	0.89	1098	1.03	1148	1.11
1100	494	0.27	594	0.31	688	0.40	775	0.49	856	0.59	931	0.69	999	0.79	1061	0.90	1117	1.04	1167	1.13
1200	509	0.28	608	0.37	701	0.46	788	0.55	870	0.65	945	0.75	1015	0.85	1078	0.95	1136	1.06	1188	1.17
1300	524	0.30	623	0.39	716	0.48	804	0.58	886	0.68	961	0.78	1032	0.88	1096	0.99	1154	1.09	1207	1.20
1400	540	0.32	639	0.41	732	0.51	819	0.61	901	0.71	977	0.82	1048	0.92	1113	1.03	1172	1.14	1226	1.26
1500	562	0.34	660	0.44	753	0.54	840	0.65	921	0.75	998	0.85	1069	0.96	1135	1.07	1195	1.18	-	-

1. Blower performance includes gas heat exchangers and 2" filters. See STATIC RESISTANCE table for additional applications.
2. See RPM SELECTION table to determine desired motor sheave setting and to determine the maximum continuous BHP.
3. kW = BHP x 0.932.
4. Field Supplied Drive

#### ZV-A4 (4.0 Ton) Side Duct

Air Flow (CFM)	Available External Static Pressure - IWG <sup>1</sup>																			
	0.2		0.4		0.6		0.8		1.0		1.2		1.4		1.6		1.8		2.0	
	RPM	BHP	RPM	BHP	RPM	BHP	RPM	BHP	RPM	BHP	RPM	BHP	RPM	BHP	RPM	BHP	RPM	BHP	RPM	BHP
					Standard 1.5 Hp & Drive						High Static 1.5 Hp & Drive				FS <sup>4</sup>					
1200	-	-	618	0.34	695	0.40	783	0.47	864	0.54	940	0.60	983	0.69	1073	0.76	1119	0.88	1178	0.94
1300	-	-	638	0.38	712	0.43	799	0.50	876	0.59	954	0.65	995	0.74	1080	0.81	1130	0.94	1188	1.00
1400	-	-	653	0.40	729	0.46	815	0.54	888	0.63	965	0.72	1007	0.78	1088	0.87	1140	1.00	1198	1.06
1500	574	0.36	666	0.42	747	0.50	831	0.59	900	0.68	975	0.78	1019	0.83	1096	0.92	1151	1.06	1207	1.11
1600	596	0.39	689	0.44	766	0.54	847	0.63	912	0.73	983	0.84	1031	0.88	1103	0.97	1162	1.13	1217	1.18
1700	619	0.43	711	0.49	786	0.58	863	0.68	925	0.79	991	0.89	1043	0.94	1112	1.04	1172	1.19	1227	1.25
1800	643	0.47	734	0.54	808	0.64	878	0.73	936	0.84	998	0.95	1055	1.00	1121	1.10	1183	1.27	1237	1.33
1900	669	0.52	757	0.61	831	0.71	894	0.79	948	0.91	1004	1.00	1067	1.06	1130	1.16	1194	1.35	-	-
2000	697	0.58	779	0.67	856	0.78	910	0.85	960	0.98	1010	1.05	1079	1.13	1140	1.23	-	-	-	-

1. Blower performance includes gas heat exchangers and 2" filters. See STATIC RESISTANCE table for additional applications.
2. See RPM SELECTION table to determine desired motor sheave setting and to determine the maximum continuous BHP.
3. kW = BHP x 0.932.
4. Field Supplied Drive.

#### ZV-A5 (5.0 Ton) Side Duct

Air Flow (CFM)	Available External Static Pressure - IWG <sup>1</sup>																			
	0.2		0.4		0.6		0.8		1.0		1.2		1.4		1.6		1.8		2.0	
	RPM	BHP	RPM	BHP	RPM	BHP	RPM	BHP	RPM	BHP	RPM	BHP	RPM	BHP	RPM	BHP	RPM	BHP	RPM	BHP
	FS <sup>4</sup>				Standard 1.5 Hp & Drive						High Static 2.0 Hp & Drive									
1500	-	-	667	0.40	747	0.50	837	0.58	904	0.59	972	0.73	1039	0.88	1096	0.92	1151	1.06	1207	1.11
1600	-	-	689	0.44	766	0.54	844	0.60	917	0.65	982	0.79	1047	0.93	1103	0.97	1162	1.13	1217	1.18
1700	615	0.43	711	0.48	786	0.58	852	0.64	931	0.73	994	0.86	1057	1.00	1112	1.04	1172	1.19	1227	1.25
1800	641	0.48	734	0.53	808	0.64	863	0.68	945	0.80	1006	0.93	1067	1.06	1121	1.10	1183	1.27	1237	1.33
1900	666	0.52	757	0.59	831	0.71	878	0.76	959	0.87	1018	0.99	1077	1.12	1130	1.16	1194	1.35	1246	1.40
2000	692	0.58	781	0.65	842	0.73	914	0.82	973	0.94	1031	1.06	1089	1.19	1140	1.23	1204	1.43	1256	1.49
2100	718	0.64	806	0.73	863	0.75	934	0.88	987	1.01	1044	1.14	1101	1.26	1151	1.31	1215	1.53	1266	1.58
2200	744	0.71	832	0.81	886	0.83	954	0.95	1002	1.09	1059	1.22	1116	1.36	1164	1.40	1226	1.63	1276	1.67
2300	770	0.79	859	0.91	907	0.90	972	1.02	1017	1.16	1074	1.31	1131	1.45	1178	1.50	1236	1.72	1286	1.78
2400	796	0.87	887	1.03	927	0.98	990	1.09	1032	1.24	1091	1.40	1150	1.56	1195	1.62	1247	1.83	1295	1.87
2500	822	0.96	916	1.17	946	1.06	1006	1.17	1047	1.32	1112	1.52	1177	1.73	1219	1.79	1258	1.95	-	-

1. Blower performance includes gas heat exchangers and 2" filters. See STATIC RESISTANCE table for additional applications.
2. See RPM SELECTION table to determine desired motor sheave setting and to determine the maximum continuous BHP.
3. kW = BHP x 0.932.
4. Field Supplied Drive.

## ZV-A3 thru -A5 Bottom Duct Application

### ZV-A3 (3.0 Ton) Bottom Duct

Air Flow (CFM)	Available External Static Pressure - IWG <sup>1</sup>																			
	0.2		0.4		0.6		0.8		1.0		1.2		1.4		1.6		1.8		2.0	
	RPM	BHP	RPM	BHP	RPM	BHP	RPM	BHP	RPM	BHP	RPM	BHP	RPM	BHP	RPM	BHP	RPM	BHP	RPM	BHP
	FS <sup>4</sup>				Standard 1.5 Hp & Drive				High Static 1.5 Hp & Drive				FS <sup>4</sup>							
900	469	0.26	580	0.34	682	0.43	775	0.52	860	0.60	936	0.69	1004	0.78	1063	0.87	1113	0.96	1155	1.05
1000	486	0.27	597	0.36	699	0.45	793	0.54	879	0.63	956	0.72	1024	0.81	1083	0.91	1135	1.00	1177	1.10
1100	504	0.29	613	0.38	714	0.47	807	0.56	892	0.66	969	0.75	1037	0.84	1098	0.93	1151	1.02	1196	1.12
1200	526	0.31	635	0.40	736	0.50	828	0.59	911	0.69	986	0.78	1053	0.87	1112	0.97	1162	1.06	1203	1.15
1300	552	0.33	657	0.42	755	0.52	844	0.62	926	0.71	1001	0.81	1067	0.90	1126	0.99	1177	1.08	1220	1.17
1400	577	0.35	679	0.46	774	0.56	862	0.65	943	0.75	1017	0.84	1084	0.93	1144	1.02	1198	1.11	-	-
1500	610	0.39	707	0.49	797	0.60	882	0.70	959	0.79	1031	0.89	1095	0.98	1154	1.07	1206	1.15	-	-

1. Blower performance includes gas heat exchangers and 2" filters. See STATIC RESISTANCE table for additional applications.
2. See RPM SELECTION table to determine desired motor sheave setting and to determine the maximum continuous BHP.
3. kW = BHP x 0.932.
4. Field Supplied Drive.

### ZV-A4 (4.0 Ton) Bottom Duct

Air Flow (CFM)	Available External Static Pressure - IWG <sup>1</sup>																			
	0.2		0.4		0.6		0.8		1.0		1.2		1.4		1.6		1.8		2.0	
	RPM	BHP	RPM	BHP	RPM	BHP	RPM	BHP	RPM	BHP	RPM	BHP	RPM	BHP	RPM	BHP	RPM	BHP	RPM	BHP
					Standard 1.5 Hp & Drive				High Static 1.5 Hp & Drive				FS <sup>4</sup>							
1200	-	-	633	0.38	728	0.47	816	0.56	898	0.65	973	0.75	1042	0.85	1104	0.95	1159	1.05	1208	1.16
1300	-	-	656	0.41	748	0.50	834	0.59	914	0.68	988	0.77	1056	0.87	1118	0.96	1174	1.07	1224	1.17
1400	586	0.37	680	0.46	769	0.55	852	0.65	930	0.74	1003	0.84	1070	0.93	1132	1.02	1189	1.12	-	-
1500	612	0.40	703	0.50	790	0.59	871	0.69	948	0.78	1019	0.88	1086	0.97	1148	1.07	1205	1.17	-	-
1600	643	0.44	731	0.53	814	0.63	893	0.73	967	0.82	1037	0.92	1103	1.01	1164	1.11	1221	1.21	-	-
1700	671	0.47	756	0.57	837	0.67	914	0.77	987	0.87	1056	0.97	1121	1.07	1183	1.17	-	-	-	-
1800	699	0.53	781	0.63	860	0.73	935	0.84	1006	0.94	1074	1.04	1139	1.14	1199	1.24	-	-	-	-
1900	726	0.58	805	0.69	881	0.80	954	0.90	1024	1.01	1092	1.12	1157	1.22	1218	1.33	-	-	-	-
2000	755	0.64	831	0.75	905	0.86	977	0.97	1046	1.08	1113	1.19	1178	1.3	-	-	-	-	-	-

1. Blower performance includes gas heat exchangers and 2" filters. See STATIC RESISTANCE table for additional applications.
2. See RPM SELECTION table to determine desired motor sheave setting and to determine the maximum continuous BHP.
3. kW = BHP x 0.932.
4. Field Supplied Drive.

### ZV-A5 (5.0 Ton) Bottom Duct

Air Flow (CFM)	Available External Static Pressure - IWG <sup>1</sup>																			
	0.2		0.4		0.6		0.8		1.0		1.2		1.4		1.6		1.8		2.0	
	RPM	BHP	RPM	BHP	RPM	BHP	RPM	BHP	RPM	BHP	RPM	BHP	RPM	BHP	RPM	BHP	RPM	BHP	RPM	BHP
	FS <sup>4</sup>				Standard 1.5 Hp & Drive				High Static 1.5 Hp & Drive				High Static 2.0 Hp & Drive							
1500	616	0.39	696	0.50	771	0.60	841	0.71	907	0.81	968	0.91	1024	1.02	1075	1.12	1122	1.23	1164	1.33
1600	643	0.43	719	0.54	791	0.64	858	0.74	921	0.85	980	0.95	1034	1.06	1084	1.16	1130	1.26	1171	1.37
1700	671	0.47	746	0.58	817	0.68	884	0.78	947	0.88	1006	0.98	1062	1.09	1113	1.19	1160	1.29	1203	1.39
1800	698	0.52	771	0.62	840	0.72	905	0.83	967	0.93	1025	1.03	1080	1.13	1131	1.24	1178	1.34	1222	1.44
1900	725	0.57	796	0.67	864	0.77	929	0.88	990	0.98	1048	1.09	1102	1.19	1154	1.29	1202	1.40	1246	1.50
2000	753	0.62	822	0.73	888	0.83	952	0.94	1012	1.04	1069	1.15	1123	1.25	1174	1.36	1222	1.46	1267	1.57
2100	782	0.68	849	0.79	913	0.89	975	1.00	1033	1.11	1090	1.21	1143	1.32	1194	1.43	1243	1.54	1288	1.64
2200	809	0.74	874	0.85	936	0.96	997	1.07	1055	1.18	1110	1.29	1164	1.39	1215	1.50	1264	1.61	1310	1.72
2300	837	0.82	900	0.93	960	1.04	1019	1.15	1076	1.26	1132	1.37	1185	1.48	1236	1.59	1285	1.70	1333	1.81
2400	865	0.89	925	1.01	984	1.12	1042	1.23	1098	1.35	1152	1.46	1205	1.57	1256	1.69	1306	1.80	-	-
2500	893	0.98	952	1.09	1009	1.21	1065	1.33	1120	1.44	1173	1.56	1226	1.67	1277	1.79	1327	1.91	-	-

1. Blower performance includes gas heat exchangers and 2" filters. See STATIC RESISTANCE table for additional applications.
2. See RPM SELECTION table to determine desired motor sheave setting and to determine the maximum continuous BHP.
3. kW = BHP x 0.932.
4. Field Supplied Drive.

## Sound Performance

### Indoor Sound Power Levels (3 thru 5 Ton)

#### Indoor Sound Power Levels (Horizontal Ducted Inlet, Standard Static Belt Drive)

UNIT DESCRIPTION / MODEL	ZV-A3 / 3 Ton / Standard Static Belt Drive			
TEST CONFIGURATION	Horizontal (Side Return) Ducted Inlet			
Indoor Blower Speed (RPM)	612 - 3 Turns Open Equivalent		709 - 1 Turn Open Equivalent	
External Static Pressure (IWG)	0.5		0.4	
Airflow (CFM)	850		1300	
Blower Motor BHP	0.37		0.40	
Octave Center Freq. Hz	ID Blower Only (dB)	Cooling Operation <sup>1</sup> (dB)	ID Blower Only (dB)	Cooling Operation <sup>1</sup> (dB)
63	73	77	73	77
125	61	70	66	71
250	56	63	60	64
500	51	56	55	57
1000	44	48	51	52
2000	41	44	48	49
4000	44	47	47	48
8000	42	44	43	44

1. Cooling Operation – ID blower, compressor and outdoor fan operating at 230 VAC.

- Tested in accordance with AHRI Standard 260-2001. Refer to 2001 Standard for Sound Rating of Ducted Air Moving and Conditioning Equipment.
- Testing datum includes effect of standard inlet air filters.
- Test duct dimension: 18 in. wide x 28 in. high x 8 ft. long, no elbows.
- Test duct termination is flush with reverberant room wall.
- Duct end (sound reflection) corrections included: (7.2, 3.4, 1.2, 0.4, 0.1, 0, 0, 0) dB at (63, 125, 250, 500, 1k, 2k, 4k, 8k) Hz respectively.

UNIT DESCRIPTION / MODEL	ZV-A4 / 4 Ton / Standard Static Belt Drive			
TEST CONFIGURATION	Horizontal (Side Return) Ducted Inlet			
Indoor Blower Speed (RPM)	612 - 3 Turns Open Equivalent		709 - 1 Turn Open Equivalent	
External Static Pressure (IWG)	0.5		0.4	
Airflow (CFM)	850		1300	
Blower Motor BHP	0.37		0.40	
Octave Center Freq. Hz	ID Blower Only (dB)	Cooling Operation <sup>1</sup> (dB)	ID Blower Only (dB)	Cooling Operation <sup>1</sup> (dB)
63	73	77	73	77
125	61	70	66	71
250	56	63	60	64
500	51	56	55	57
1000	44	48	51	52
2000	41	44	48	49
4000	44	47	47	48
8000	42	44	43	44

1. Cooling Operation – ID blower, compressor and outdoor fan operating at 230 VAC.

- Tested in accordance with AHRI Standard 260-2001. Refer to 2001 Standard for Sound Rating of Ducted Air Moving and Conditioning Equipment.
- Testing datum includes effect of standard inlet air filters.
- Test duct dimension: 18 in. wide x 28 in. high x 8 ft. long, no elbows.
- Test duct termination is flush with reverberant room wall.
- Duct end (sound reflection) corrections included: (7.2, 3.4, 1.2, 0.4, 0.1, 0, 0, 0) dB at (63, 125, 250, 500, 1k, 2k, 4k, 8k) Hz respectively.

UNIT DESCRIPTION / MODEL	ZV-A5 / 5 Ton / Standard Static Belt Drive			
TEST CONFIGURATION	Horizontal (Side Return) Ducted Inlet			
Indoor Blower Speed (RPM)	814 - 3 Turns Open Equivalent		918 - 1 Turn Open Equivalent	
External Static Pressure (IWG)	0.6		0.8	
Airflow (CFM)	1700		1950	
Blower Motor BHP	0.42		0.88	
Octave Center Freq. Hz	ID Blower Only (dB)	Cooling Operation <sup>1</sup> (dB)	ID Blower Only (dB)	Cooling Operation <sup>1</sup> (dB)
63	77	81	85	82
125	71	80	68	81
250	63	67	64	68
500	58	60	60	61
1000	56	57	58	59
2000	52	53	55	55
4000	51	51	54	54
8000	47	47	48	48

1. Cooling Operation – ID blower, compressor and outdoor fan operating at 230 VAC.

- Tested in accordance with AHRI Standard 260-2001. Refer to 2001 Standard for Sound Rating of Ducted Air Moving and Conditioning Equipment.
- Testing datum includes effect of standard inlet air filters.
- Test duct dimension: 18 in. wide x 28 in. high x 8 ft. long, no elbows.
- Test duct termination is flush with reverberant room wall.
- Duct end (sound reflection) corrections included: (7.2, 3.4, 1.2, 0.4, 0.1, 0, 0, 0) dB at (63, 125, 250, 500, 1k, 2k, 4k, 8k) Hz respectively.

### Indoor Sound Power Levels (Horizontal Ducted Discharge, Standard Static Belt Drive)

UNIT DESCRIPTION / MODEL	ZV-A3 / 3 Ton / Standard Static Belt Drive			
TEST CONFIGURATION	Horizontal (Side Supply) Ducted Discharge			
Indoor Blower Speed (RPM)	610 - 3 Turns Open Equivalent		710 - 1 Turn Open Equivalent	
External Static Pressure (IWG)	0.5		0.6	
Airflow (CFM)	850		950	
Blower Motor BHP	0.37		0.42	
Octave Center Freq. Hz	ID Blower Only (dB)	Cooling Operation <sup>1</sup> (dB)	ID Blower Only (dB)	Cooling Operation <sup>1</sup> (dB)
63	77	78	79	79
125	74	75	75	76
250	66	68	70	70
500	61	61	65	64
1000	60	62	65	66
2000	52	52	58	58
4000	52	52	59	60
8000	44	44	50	50

1. Cooling Operation – ID blower, compressor and outdoor fan operating at 230 VAC.

- Tested in accordance with AHRI Standard 260-2001. Refer to 2001 Standard for Sound Rating of Ducted Air Moving and Conditioning Equipment.
- Testing datum includes effect of standard inlet air filters.
- Test duct dimension: 18 in. wide x 28 in. high x 8 ft. long, no elbows.
- Test duct termination is flush with reverberant room wall.
- Duct end (sound reflection) corrections included: (7.2, 3.4, 1.2, 0.4, 0.1, 0, 0, 0) dB at (63, 125, 250, 500, 1k, 2k, 4k, 8k) Hz respectively.

UNIT DESCRIPTION / MODEL	ZV-A4 / 4 Ton / Standard Static Belt Drive			
TEST CONFIGURATION	Horizontal (Side Supply) Ducted Discharge			
Indoor Blower Speed (RPM)	610 - 3 Turns Open Equivalent		710 - 1 Turn Open Equivalent	
External Static Pressure (IWG)	0.5		0.6	
Airflow (CFM)	850		950	
Blower Motor BHP	0.37		0.42	
Octave Center Freq. Hz	ID Blower Only (dB)	Cooling Operation <sup>1</sup> (dB)	ID Blower Only (dB)	Cooling Operation <sup>1</sup> (dB)
63	77	78	79	79
125	74	75	75	76
250	66	68	70	70
500	61	61	65	64
1000	60	62	65	66
2000	52	52	58	58
4000	52	52	59	60
8000	44	44	50	50

1. Cooling Operation – ID blower, compressor and outdoor fan operating at 230 VAC.

- Tested in accordance with AHRI Standard 260-2001. Refer to 2001 Standard for Sound Rating of Ducted Air Moving and Conditioning Equipment.
- Testing datum includes effect of standard inlet air filters.
- Test duct dimension: 18 in. wide x 28 in. high x 8 ft. long, no elbows.
- Test duct termination is flush with reverberant room wall.
- Duct end (sound reflection) corrections included: (7.2, 3.4, 1.2, 0.4, 0.1, 0, 0, 0) dB at (63, 125, 250, 500, 1k, 2k, 4k, 8k) Hz respectively.

UNIT DESCRIPTION / MODEL	ZV-A5 / 5 Ton / Standard Static Belt Drive			
TEST CONFIGURATION	Horizontal (Side Supply) Ducted Discharge			
Indoor Blower Speed (RPM)	810 - 3 Turns Open Equivalent		918 - 1 Turn Open Equivalent	
External Static Pressure (IWG)	0.4		0.8	
Airflow (CFM)	2050		1950	
Blower Motor BHP	0.73		0.88	
Octave Center Freq. Hz	ID Blower Only (dB)	Cooling Operation <sup>1</sup> (dB)	ID Blower Only (dB)	Cooling Operation <sup>1</sup> (dB)
63	85	83	83	83
125	78	79	76	79
250	69	70	69	70
500	68	68	68	68
1000	64	64	65	65
2000	63	63	64	64
4000	64	64	64	64
8000	59	59	59	60

1. Cooling Operation – ID blower, compressor and outdoor fan operating at 230 VAC.

- Tested in accordance with AHRI Standard 260-2001. Refer to 2001 Standard for Sound Rating of Ducted Air Moving and Conditioning Equipment.
- Testing datum includes effect of standard inlet air filters.
- Test duct dimension: 18 in. wide x 28 in. high x 8 ft. long, no elbows.
- Test duct termination is flush with reverberant room wall.
- Duct end (sound reflection) corrections included: (7.2, 3.4, 1.2, 0.4, 0.1, 0, 0, 0) dB at (63, 125, 250, 500, 1k, 2k, 4k, 8k) Hz respectively.



## Indoor Sound Power Levels (Vertical Ducted Inlet, Standard Static Belt Drive)

UNIT DESCRIPTION / MODEL	ZV-A3 / 3 Ton / Standard Static Belt Drive			
TEST CONFIGURATION	Vertical (Bottom Return) Ducted Inlet			
Indoor Blower Speed (RPM)	609 - 3 Turns Open Equivalent		708 - 1 Turn Open Equivalent	
External Static Pressure (IWG)	0.4		0.4	
Airflow (CFM)	850		1150	
Blower Motor BHP	0.32		0.38	
Octave Center Freq. Hz	ID Blower Only (dB)	Cooling Operation <sup>1</sup> (dB)	ID Blower Only (dB)	Cooling Operation <sup>1</sup> (dB)
63	76	76	74	76
125	63	70	66	70
250	55	62	59	62
500	54	55	58	59
1000	48	48	53	53
2000	44	44	48	48
4000	41	44	45	46
8000	42	43	43	44

1. Differentials for Cooling Operation (IDB, COMP, & ODF) are logarithmically calculated from the horizontal flow sound test.
- Tested in accordance with AHRI Standard 260-2001. Refer to 2001 Standard for Sound Rating of Ducted Air Moving and Conditioning Equipment.
  - Testing datum includes effect of standard inlet air filters.
  - Test duct dimension: 18 in. wide x 28 in. high x 8 ft. long, no elbows.
  - Test duct termination is flush with reverberant room wall.
  - Duct end (sound reflection) corrections included: (7.2, 3.4, 1.2, 0.4, 0.1, 0, 0, 0) dB at (63, 125, 250, 500, 1k, 2k, 4k, 8k) Hz respectively.

UNIT DESCRIPTION / MODEL	ZV-A4 / 4 Ton / Standard Static Belt Drive			
TEST CONFIGURATION	Vertical (Bottom Return) Ducted Inlet			
Indoor Blower Speed (RPM)	609 - 3 Turns Open Equivalent		708 - 1 Turn Open Equivalent	
External Static Pressure (IWG)	0.4		0.4	
Airflow (CFM)	850		1150	
Blower Motor BHP	0.32		0.38	
Octave Center Freq. Hz	ID Blower Only (dB)	Cooling Operation <sup>1</sup> (dB)	ID Blower Only (dB)	Cooling Operation <sup>1</sup> (dB)
63	76	76	74	76
125	63	70	66	70
250	55	62	59	62
500	54	55	58	59
1000	48	48	53	53
2000	44	44	48	48
4000	41	44	45	46
8000	42	43	43	44

1. Differentials for Cooling Operation (IDB, COMP, & ODF) are logarithmically calculated from the horizontal flow sound test.
- Tested in accordance with AHRI Standard 260-2001. Refer to 2001 Standard for Sound Rating of Ducted Air Moving and Conditioning Equipment.
  - Testing datum includes effect of standard inlet air filters.
  - Test duct dimension: 18 in. wide x 28 in. high x 8 ft. long, no elbows.
  - Test duct termination is flush with reverberant room wall.
  - Duct end (sound reflection) corrections included: (7.2, 3.4, 1.2, 0.4, 0.1, 0, 0, 0) dB at (63, 125, 250, 500, 1k, 2k, 4k, 8k) Hz respectively.

UNIT DESCRIPTION / MODEL	ZV-A5 / 5 Ton / Standard Static Belt Drive			
TEST CONFIGURATION	Vertical (Bottom Return) Ducted Inlet			
Indoor Blower Speed (RPM)	812 - 3 Turns Open Equivalent		915- 1 Turn Open Equivalent	
External Static Pressure (IWG)	0.6		0.8	
Airflow (CFM)	1575		1800	
Blower Motor BHP	0.64		0.83	
Octave Center Freq. Hz	ID Blower Only (dB)	Cooling Operation <sup>1</sup> (dB)	ID Blower Only (dB)	Cooling Operation <sup>1</sup> (dB)
63	75	78	80	80
125	66	80	69	81
250	59	66	62	65
500	60	60	63	63
1000	57	57	60	60
2000	52	53	55	55
4000	49	50	53	53
8000	44	45	47	47

1. Differentials for Cooling Operation (IDB, COMP, & ODF) are logarithmically calculated from the horizontal flow sound test.

- Tested in accordance with AHRI Standard 260-2001. Refer to 2001 Standard for Sound Rating of Ducted Air Moving and Conditioning Equipment.
- Testing datum includes effect of standard inlet air filters.
- Test duct dimension: 18 in. wide x 28 in. high x 8 ft. long, no elbows.
- Test duct termination is flush with reverberant room wall.
- Duct end (sound reflection) corrections included: (7.2, 3.4, 1.2, 0.4, 0.1, 0, 0, 0) dB at (63, 125, 250, 500, 1k, 2k, 4k, 8k) Hz respectively.

### Indoor Sound Power Levels (Vertical Ducted Discharge, Standard Static Belt Drive)

UNIT DESCRIPTION / MODEL	ZV-A3 / 3 Ton / Standard Static Belt Drive			
TEST CONFIGURATION	Vertical (Bottom Supply) Ducted Discharge			
Indoor Blower Speed (RPM)	609 - 3 Turns Open Equivalent		712 - 1 Turn Open Equivalent	
External Static Pressure (IWG)	0.4		0.6	
Airflow (CFM)	850		950	
Blower Motor BHP	0.32		0.42	
Octave Center Freq. Hz	ID Blower Only (dB)	Cooling Operation <sup>1</sup> (dB)	ID Blower Only (dB)	Cooling Operation <sup>1</sup> (dB)
63	76	77	81	81
125	68	68	72	72
250	55	65	57	57
500	56	57	57	57
1000	51	57	52	56
2000	49	49	50	50
4000	48	48	49	51
8000	46	46	47	48

1. Differentials for Cooling Operation (IDB, COMP, & ODF) are logarithmically calculated from the horizontal flow sound test.

- Tested in accordance with AHRI Standard 260-2001. Refer to 2001 Standard for Sound Rating of Ducted Air Moving and Conditioning Equipment.
- Testing datum includes effect of standard inlet air filters.
- Test duct dimension: 18 in. wide x 28 in. high x 8 ft. long, no elbows.
- Test duct termination is flush with reverberant room wall.
- Duct end (sound reflection) corrections included: (7.2, 3.4, 1.2, 0.4, 0.1, 0, 0, 0) dB at (63, 125, 250, 500, 1k, 2k, 4k, 8k) Hz respectively.

UNIT DESCRIPTION / MODEL	ZV-A4 / 4 Ton / Standard Static Belt Drive			
TEST CONFIGURATION	Vertical (Bottom Supply) Ducted Discharge			
Indoor Blower Speed (RPM)	609 - 3 Turns Open Equivalent		712 - 1 Turn Open Equivalent	
External Static Pressure (IWG)	0.4		0.6	
Airflow (CFM)	850		950	
Blower Motor BHP	0.32		0.42	
Octave Center Freq. Hz	ID Blower Only (dB)	Cooling Operation <sup>1</sup> (dB)	ID Blower Only (dB)	Cooling Operation <sup>1</sup> (dB)
63	76	77	81	81
125	68	68	72	72
250	55	65	57	57
500	56	57	57	57
1000	51	57	52	56
2000	49	49	50	50
4000	48	48	49	51
8000	46	46	47	48

1. Differentials for Cooling Operation (IDB, COMP, & ODF) are logarithmically calculated from the horizontal flow sound test.

- Tested in accordance with AHRI Standard 260-2001. Refer to 2001 Standard for Sound Rating of Ducted Air Moving and Conditioning Equipment.
- Testing datum includes effect of standard inlet air filters.
- Test duct dimension: 18 in. wide x 28 in. high x 8 ft. long, no elbows.
- Test duct termination is flush with reverberant room wall.
- Duct end (sound reflection) corrections included: (7.2, 3.4, 1.2, 0.4, 0.1, 0, 0, 0) dB at (63, 125, 250, 500, 1k, 2k, 4k, 8k) Hz respectively.

UNIT DESCRIPTION / MODEL	ZV-A5 / 5 Ton / Standard Static Belt Drive			
TEST CONFIGURATION	Vertical (Bottom Supply) Ducted Discharge			
Indoor Blower Speed (RPM)	809 - 3 Turns Open Equivalent		914 - 1 Turn Open Equivalent	
External Static Pressure (IWG)	0.5		0.8	
Airflow (CFM)	1700		1800	
Blower Motor BHP	0.64		0.83	
Octave Center Freq. Hz	ID Blower Only (dB)	Cooling Operation <sup>1</sup> (dB)	ID Blower Only (dB)	Cooling Operation <sup>1</sup> (dB)
63	81	81	79	79
125	75	75	75	76
250	65	65	63	63
500	67	67	67	67
1000	63	63	63	63
2000	61	62	61	61
4000	62	62	61	61
8000	57	57	56	56

1. Differentials for Cooling Operation (IDB, COMP, & ODF) are logarithmically calculated from the horizontal flow sound test.

- Tested in accordance with AHRI Standard 260-2001. Refer to 2001 Standard for Sound Rating of Ducted Air Moving and Conditioning Equipment.
- Testing datum includes effect of standard inlet air filters.
- Test duct dimension: 18 in. wide x 28 in. high x 8 ft. long, no elbows.
- Test duct termination is flush with reverberant room wall.
- Duct end (sound reflection) corrections included: (7.2, 3.4, 1.2, 0.4, 0.1, 0, 0, 0) dB at (63, 125, 250, 500, 1k, 2k, 4k, 8k) Hz respectively.

### Indoor Sound Power Levels (Horizontal Ducted Inlet, High Static Belt Drive)

UNIT DESCRIPTION / MODEL	ZV-A3 / 3 Ton / High Static Belt Drive					
TEST CONFIGURATION	Horizontal (Side Return) Ducted Inlet					
Indoor Blower Speed (RPM)	876 - 4 Turns Open Equivalent		1,064 - 1/2 Turn Open Equivalent		1,190 - 2.5 Turns Open Equivalent <sup>1</sup>	
External Static Pressure (IWG)	1.0		1.6		2.0 <sup>1</sup>	
Nominal Airflow (CFM)	1,200		1,100		1,000	
Blower Motor BHP	0.64		0.93		1.08	
Octave Center Freq. Hz	ID Blower Only (dB)	Cooling Operation <sup>2</sup> (dB)	ID Blower Only (dB)	Cooling Operation <sup>2</sup> (dB)	ID Blower Only (dB)	Cooling Operation <sup>2</sup> (dB)
63	75	80	81	81	81	83
125	69	71	71	73	73	75
250	62	68	66	71	68	70
500	54	56	57	59	59	60
1000	52	56	56	58	58	60
2000	47	49	52	52	54	56
4000	43	45	48	49	51	53
8000	43	45	45	46	47	48

- Requires driven pulley #AK-56, normal high static pulley is an #AK-69.
- Cooling Operation – ID blower, compressor and outdoor fan operating at 230 VAC.
  - Tested in accordance with AHRI Standard 260-2001. Refer to 2001 Standard for Sound Rating of Ducted Air Moving and Conditioning Equipment.
  - Testing datum includes effect of standard inlet air filters.
  - Test duct dimension: 18 in. wide x 28 in. high x 8 ft. long, no elbows.
  - Test duct termination is flush with reverberant room wall.
  - Duct end (sound reflection) corrections included: (7.2, 3.4, 1.2, 0.4, 0.1, 0, 0, 0) dB at (63, 125, 250, 500, 1k, 2k, 4k, 8k) Hz respectively.

UNIT DESCRIPTION / MODEL	ZV-A4 / 4 Ton / High Static Belt Drive					
TEST CONFIGURATION	Horizontal (Side Return) Ducted Inlet					
Indoor Blower Speed (RPM)	965 - 5.5 Turns Open Equivalent		1,088 - 4 Turns Open Equivalent		1,186 - 2.5 Turns Open Equivalent	
External Static Pressure (IWG)	1.0		1.6		2.0	
Nominal Airflow (CFM)	1,600		1,400		1,200	
Blower Motor BHP	0.86		1.03		1.13	
Octave Center Freq. Hz	ID Blower Only (dB)	Cooling Operation <sup>1</sup> (dB)	ID Blower Only (dB)	Cooling Operation <sup>1</sup> (dB)	ID Blower Only (dB)	Cooling Operation <sup>1</sup> (dB)
63	74	80	77	80	81	81
125	69	74	72	75	75	76
250	68	68	68	69	70	71
500	62	62	60	61	61	63
1000	60	61	58	58	59	60
2000	57	57	53	54	55	56
4000	56	56	49	50	51	52
8000	54	54	45	47	47	48

- Cooling Operation – ID blower, compressor and outdoor fan operating at 230 VAC.
  - Tested in accordance with AHRI Standard 260-2001. Refer to 2001 Standard for Sound Rating of Ducted Air Moving and Conditioning Equipment.
  - Testing datum includes effect of standard inlet air filters.
  - Test duct dimension: 18 in. wide x 28 in. high x 8 ft. long, no elbows.
  - Test duct termination is flush with reverberant room wall.
  - Duct end (sound reflection) corrections included: (7.2, 3.4, 1.2, 0.4, 0.1, 0, 0, 0) dB at (63, 125, 250, 500, 1k, 2k, 4k, 8k) Hz respectively.

UNIT DESCRIPTION / MODEL	ZV-A5 / 5 Ton / High Static Belt Drive					
TEST CONFIGURATION	Horizontal (Side Return) Ducted Inlet					
Indoor Blower Speed (RPM)	1,012- 5.5 Turns Open Equivalent		1,134 - 3 Turns Open Equivalent		1,174 - 2 Turns Open Equivalent	
External Static Pressure (IWG)	1.0		1.6		2.0	
Nominal Airflow (CFM)	2,000		1,800		1,600	
Blower Motor BHP	1.04		1.25		1.39	
Octave Center Freq. Hz	ID Blower Only (dB)	Cooling Operation <sup>1</sup> (dB)	ID Blower Only (dB)	Cooling Operation <sup>1</sup> (dB)	ID Blower Only (dB)	Cooling Operation <sup>1</sup> (dB)
63	76	78	78	79	79	81
125	70	73	73	76	74	77
250	68	70	68	69	69	70
500	61	62	61	62	60	62
1000	61	62	61	62	58	60
2000	57	58	57	58	54	56
4000	56	56	55	56	52	53
8000	50	50	50	50	47	48

1. Cooling Operation – ID blower, compressor and outdoor fan operating at 230 VAC.

- Tested in accordance with AHRI Standard 260-2001. Refer to 2001 Standard for Sound Rating of Ducted Air Moving and Conditioning Equipment.
- Testing datum includes effect of standard inlet air filters.
- Test duct dimension: 18 in. wide x 28 in. high x 8 ft. long, no elbows.
- Test duct termination is flush with reverberant room wall.
- Duct end (sound reflection) corrections included: (7.2, 3.4, 1.2, 0.4, 0.1, 0, 0, 0) dB at (63, 125, 250, 500, 1k, 2k, 4k, 8k) Hz respectively.

### Indoor Sound Power Levels (Horizontal Ducted Discharge, High Static Belt Drive)

UNIT DESCRIPTION / MODEL	ZV-A3 / 3 Ton / High Static Belt Drive					
TEST CONFIGURATION	Horizontal (Side Supply) Ducted Discharge					
Indoor Blower Speed (RPM)	896 - 3.5 Turns Open Equivalent		1,072 - Fully Closed Equivalent		1,170 - 2.5 Turns Open Equivalent <sup>1</sup>	
External Static Pressure (IWG)	1.0		1.6		2.0 <sup>1</sup>	
Nominal Airflow (CFM)	1,200		1,100		1,000	
Blower Motor BHP	0.64		0.93		1.08	
Octave Center Freq. Hz	ID Blower Only (dB)	Cooling Operation <sup>2</sup> (dB)	ID Blower Only (dB)	Cooling Operation <sup>2</sup> (dB)	ID Blower Only (dB)	Cooling Operation <sup>2</sup> (dB)
63	77	81	83	84	83	84
125	74	76	76	77	80	80
250	67	68	70	70	72	73
500	65	66	67	67	67	68
1000	61	62	67	67	66	69
2000	58	60	63	63	63	64
4000	57	59	62	62	62	63
8000	51	53	56	57	56	58

1. Requires driven pulley #AK-56, normal high static pulley is an #AK-69.

2. Cooling Operation – ID blower, compressor and outdoor fan operating at 230 VAC.

- Tested in accordance with AHRI Standard 260-2001. Refer to 2001 Standard for Sound Rating of Ducted Air Moving and Conditioning Equipment.
- Testing datum includes effect of standard inlet air filters.
- Test duct dimension: 18 in. wide x 28 in. high x 8 ft. long, no elbows.
- Test duct termination is flush with reverberant room wall.
- Duct end (sound reflection) corrections included: (7.2, 3.4, 1.2, 0.4, 0.1, 0, 0, 0) dB at (63, 125, 250, 500, 1k, 2k, 4k, 8k) Hz respectively.

UNIT DESCRIPTION / MODEL	ZV-A4 / 4 Ton / High Static Belt Drive					
TEST CONFIGURATION	Horizontal (Side Supply) Ducted Discharge					
Indoor Blower Speed (RPM)	922 - 6 Turns Open Equivalent		1,069 - 4 Turns Open Equivalent		1,165 - 2.5 Turns Open Equivalent	
External Static Pressure (IWG)	1.0		1.6		2.0	
Nominal Airflow (CFM)	1,600		1,400		1,200	
Blower Motor BHP	0.86		1.03		1.13	
Octave Center Freq. Hz	ID Blower Only (dB)	Cooling Operation <sup>1</sup> (dB)	ID Blower Only (dB)	Cooling Operation <sup>1</sup> (dB)	ID Blower Only (dB)	Cooling Operation <sup>1</sup> (dB)
63	80	82	82	83	84	84
125	76	77	76	77	78	79
250	71	72	72	72	74	74
500	69	69	69	69	70	70
1000	65	65	69	69	70	70
2000	64	64	64	64	65	65
4000	63	63	63	63	64	64
8000	58	58	58	58	59	59

1. Cooling Operation – ID blower, compressor and outdoor fan operating at 230 VAC.

- Tested in accordance with AHRI Standard 260-2001. Refer to 2001 Standard for Sound Rating of Ducted Air Moving and Conditioning Equipment.
- Testing datum includes effect of standard inlet air filters.
- Test duct dimension: 18 in. wide x 28 in. high x 8 ft. long, no elbows.
- Test duct termination is flush with reverberant room wall.
- Duct end (sound reflection) corrections included: (7.2, 3.4, 1.2, 0.4, 0.1, 0, 0, 0) dB at (63, 125, 250, 500, 1k, 2k, 4k, 8k) Hz respectively.

UNIT DESCRIPTION / MODEL	ZV-A5 / 5 Ton / High Static Belt Drive					
TEST CONFIGURATION	Horizontal (Side Supply) Ducted Discharge					
Indoor Blower Speed (RPM)	1,009- 5.5 Turns Open Equivalent		1,131 - 3 Turns Open Equivalent		1,184 - 2 Turns Open Equivalent	
External Static Pressure (IWG)	1.0		1.6		2.0	
Nominal Airflow (CFM)	2,000		1,800		1,600	
Blower Motor BHP	1.04		1.25		1.39	
Octave Center Freq. Hz	ID Blower Only (dB)	Cooling Operation <sup>1</sup> (dB)	ID Blower Only (dB)	Cooling Operation <sup>1</sup> (dB)	ID Blower Only (dB)	Cooling Operation <sup>1</sup> (dB)
63	84	85	82	83	82	83
125	78	79	79	79	78	79
250	75	75	74	75	73	73
500	71	71	70	71	69	69
1000	69	69	71	71	71	72
2000	66	67	67	67	66	66
4000	66	66	66	67	66	66
8000	61	62	61	62	60	60

1. Cooling Operation – ID blower, compressor and outdoor fan operating at 230 VAC.

- Tested in accordance with AHRI Standard 260-2001. Refer to 2001 Standard for Sound Rating of Ducted Air Moving and Conditioning Equipment.
- Testing datum includes effect of standard inlet air filters.
- Test duct dimension: 18 in. wide x 28 in. high x 8 ft. long, no elbows.
- Test duct termination is flush with reverberant room wall.
- Duct end (sound reflection) corrections included: (7.2, 3.4, 1.2, 0.4, 0.1, 0, 0, 0) dB at (63, 125, 250, 500, 1k, 2k, 4k, 8k) Hz respectively.

**Indoor Sound Power Levels (Vertical Ducted Inlet, High Static Belt Drive)**

UNIT DESCRIPTION / MODEL	ZV-A3 / 3 Ton / High Static Belt Drive					
TEST CONFIGURATION	Vertical (Bottom Return) Ducted Inlet					
Indoor Blower Speed (RPM)	927 - 3 Turns Open Equivalent		1,085 - 1/2 Turn Open Equivalent		1,190 - 2.5 Turns Open Equivalent <sup>1</sup>	
External Static Pressure (IWG)	1.0		1.6		2.0 <sup>1</sup>	
Nominal Airflow (CFM)	1,200		1,100		1,000	
Blower Motor BHP	0.68		0.93		1.09	
Octave Center Freq. Hz	ID Blower Only (dB)	Cooling Operation <sup>2</sup> (dB)	ID Blower Only (dB)	Cooling Operation <sup>2</sup> (dB)	ID Blower Only (dB)	Cooling Operation <sup>2</sup> (dB)
63	77	79	82	83	79	81
125	68	69	70	71	72	73
250	60	67	62	69	64	67
500	58	58	63	63	62	63
1000	54	55	60	60	60	60
2000	48	49	56	56	55	55
4000	43	44	48	49	51	51
8000	44	44	45	46	47	47

1. Requires driven pulley #AK-56, normal high static pulley is an #AK-69.

2. Differentials for Cooling Operation (IDB, COMP, & ODF) are logarithmically calculated from the horizontal flow sound test.

- Tested in accordance with AHRI Standard 260-2001. Refer to 2001 Standard for Sound Rating of Ducted Air Moving and Conditioning Equipment.
- Testing datum includes effect of standard inlet air filters.
- Test duct dimension: 18 in. wide x 28 in. high x 8 ft. long, no elbows.
- Test duct termination is flush with reverberant room wall.
- Duct end (sound reflection) corrections included: (7.2, 3.4, 1.2, 0.4, 0.1, 0, 0, 0) dB at (63, 125, 250, 500, 1k, 2k, 4k, 8k) Hz respectively.

UNIT DESCRIPTION / MODEL	ZV-A4 / 4 Ton / High Static Belt Drive					
TEST CONFIGURATION	Vertical (Bottom Return) Ducted Inlet					
Indoor Blower Speed (RPM)	968 - 5.5 Turns Open Equivalent		1,120 - 3.5 Turns Open Equivalent		1,218 - 2.0 Turns Open Equivalent	
External Static Pressure (IWG)	1.0		1.6		2.0	
Nominal Airflow (CFM)	1,600		1,400		1,200	
Blower Motor BHP	0.86		1.03		1.13	
Octave Center Freq. Hz	ID Blower Only (dB)	Cooling Operation <sup>1</sup> (dB)	ID Blower Only (dB)	Cooling Operation <sup>1</sup> (dB)	ID Blower Only (dB)	Cooling Operation <sup>1</sup> (dB)
63	77	79	78	78	81	81
125	69	73	71	73	73	74
250	63	63	63	64	66	66
500	63	64	62	63	64	64
1000	59	59	59	59	61	61
2000	54	54	53	54	56	56
4000	49	49	48	48	50	51
8000	45	46	45	46	47	47

1. Differentials for Cooling Operation (IDB, COMP, & ODF) are logarithmically calculated from the horizontal flow sound test.

- Tested in accordance with AHRI Standard 260-2001. Refer to 2001 Standard for Sound Rating of Ducted Air Moving and Conditioning Equipment.
- Testing datum includes effect of standard inlet air filters.
- Test duct dimension: 18 in. wide x 28 in. high x 8 ft. long, no elbows.
- Test duct termination is flush with reverberant room wall.
- Duct end (sound reflection) corrections included: (7.2, 3.4, 1.2, 0.4, 0.1, 0, 0, 0) dB at (63, 125, 250, 500, 1k, 2k, 4k, 8k) Hz respectively.



UNIT DESCRIPTION / MODEL	ZV-A5 / 5 Ton / High Static Belt Drive					
TEST CONFIGURATION	Vertical (Bottom Return) Ducted Inlet					
Indoor Blower Speed (RPM)	1,039 - 5 Turns Open Equivalent		1,143 - 3 Turns Open Equivalent		1,201 - 2 Turns Open Equivalent	
External Static Pressure (IWG)	1.0		1.6		2.0	
Nominal Airflow (CFM)	2,000		1,800		1,600	
Blower Motor BHP	1.11		1.25		1.39	
Octave Center Freq. Hz	ID Blower Only (dB)	Cooling Operation <sup>1</sup> (dB)	ID Blower Only (dB)	Cooling Operation <sup>1</sup> (dB)	ID Blower Only (dB)	Cooling Operation <sup>1</sup> (dB)
63	79	80	77	77	81	81
125	74	75	71	73	73	74
250	63	65	63	64	63	65
500	62	63	64	64	62	62
1000	61	61	61	61	59	59
2000	55	56	55	56	54	55
4000	52	52	50	51	50	50
8000	47	47	46	46	46	46

- Differentials for Cooling Operation (IDB, COMP, & ODF) are logarithmically calculated from the horizontal flow sound test.
- Tested in accordance with AHRI Standard 260-2001. Refer to 2001 Standard for Sound Rating of Ducted Air Moving and Conditioning Equipment.
  - Testing datum includes effect of standard inlet air filters.
  - Test duct dimension: 18 in. wide x 28 in. high x 8 ft. long, no elbows.
  - Test duct termination is flush with reverberant room wall.
  - Duct end (sound reflection) corrections included: (7.2, 3.4, 1.2, 0.4, 0.1, 0, 0, 0) dB at (63, 125, 250, 500, 1k, 2k, 4k, 8k) Hz respectively.

### Indoor Sound Power Levels (Vertical Ducted Discharge, High Static Belt Drive)

UNIT DESCRIPTION / MODEL	ZV-A3 / 3 Ton / High Static Belt Drive					
TEST CONFIGURATION	Vertical (Bottom Supply) Ducted Discharge					
Indoor Blower Speed (RPM)	920 - 3.0 Turns Open Equivalent		1,074 - Fully Closed Equivalent		1,189 - 2.0 Turns Open Equivalent <sup>1</sup>	
External Static Pressure (IWG)	1.0		1.6		2.0 <sup>1</sup>	
Nominal Airflow (CFM)	1,200		1,100		1,000	
Blower Motor BHP	0.68		0.93		1.09	
Octave Center Freq. Hz	ID Blower Only (dB)	Cooling Operation <sup>2</sup> (dB)	ID Blower Only (dB)	Cooling Operation <sup>2</sup> (dB)	ID Blower Only (dB)	Cooling Operation <sup>2</sup> (dB)
63	81	82	81	81	82	82
125	78	78	78	78	81	81
250	69	70	70	71	74	74
500	67	68	68	69	71	71
1000	62	63	67	68	70	71
2000	60	61	62	63	65	66
4000	61	61	63	63	66	66
8000	54	55	57	57	60	61

- Requires driven pulley #AK-56, normal high static pulley is an #AK-69.
- Differentials for Cooling Operation (IDB, COMP, & ODF) are logarithmically calculated from the horizontal flow sound test.
- Tested in accordance with AHRI Standard 260-2001. Refer to 2001 Standard for Sound Rating of Ducted Air Moving and Conditioning Equipment.
  - Testing datum includes effect of standard inlet air filters.
  - Test duct dimension: 18 in. wide x 28 in. high x 8 ft. long, no elbows.
  - Test duct termination is flush with reverberant room wall.
  - Duct end (sound reflection) corrections included: (7.2, 3.4, 1.2, 0.4, 0.1, 0, 0, 0) dB at (63, 125, 250, 500, 1k, 2k, 4k, 8k) Hz respectively.

UNIT DESCRIPTION / MODEL	ZV-A4 / 4 Ton / High Static Belt Drive					
TEST CONFIGURATION	Vertical (Bottom Supply) Ducted Discharge					
Indoor Blower Speed (RPM)	962 - 5.5 Turns Open Equivalent		1,092 - 3.5 Turns Open Equivalent		1,190 - 2.0 Turns Open Equivalent	
External Static Pressure (IWG)	1.0		1.6		2.0	
Nominal Airflow (CFM)	1,600		1,400		1,200	
Blower Motor BHP	0.86		1.03		1.13	
Octave Center Freq. Hz	ID Blower Only (dB)	Cooling Operation <sup>1</sup> (dB)	ID Blower Only (dB)	Cooling Operation <sup>1</sup> (dB)	ID Blower Only (dB)	Cooling Operation <sup>1</sup> (dB)
63	83	84	82	82	83	83
125	80	81	79	80	80	81
250	75	75	74	75	75	75
500	71	72	70	71	71	72
1000	66	67	70	71	72	72
2000	63	64	64	64	65	65
4000	64	64	64	64	65	66
8000	58	59	59	59	60	60

1. Differentials for Cooling Operation (IDB, COMP, & ODF) are logarithmically calculated from the horizontal flow sound test.

- Tested in accordance with AHRI Standard 260-2001. Refer to 2001 Standard for Sound Rating of Ducted Air Moving and Conditioning Equipment.
- Testing datum includes effect of standard inlet air filters.
- Test duct dimension: 18 in. wide x 28 in. high x 8 ft. long, no elbows.
- Test duct termination is flush with reverberant room wall.
- Duct end (sound reflection) corrections included: (7.2, 3.4, 1.2, 0.4, 0.1, 0, 0, 0) dB at (63, 125, 250, 500, 1k, 2k, 4k, 8k) Hz respectively.

UNIT DESCRIPTION / MODEL	ZV-A5 / 5 Ton / High Static Belt Drive					
TEST CONFIGURATION	Vertical (Bottom Supply) Ducted Discharge					
Indoor Blower Speed (RPM)	1,033 - 5.5 Turns Open Equivalent		1,135 - 3 turns Open Equivalent		1,175 - 2.5 Turns Open Equivalent	
External Static Pressure (IWG)	1.0		1.6		2.0	
Nominal Airflow (CFM)	2,000		1,135		1,175	
Blower Motor BHP	1.11		1.25		1.39	
Octave Center Freq. Hz	ID Blower Only (dB)	Cooling Operation <sup>1</sup> (dB)	ID Blower Only (dB)	Cooling Operation <sup>1</sup> (dB)	ID Blower Only (dB)	Cooling Operation <sup>1</sup> (dB)
63	83	83	83	83	85	86
125	84	84	82	82	79	81
250	79	80	77	78	66	66
500	73	73	70	71	65	66
1000	69	70	69	70	61	65
2000	67	67	65	66	60	61
4000	67	68	66	67	61	62
8000	62	63	60	61	54	54

1. Differentials for Cooling Operation (IDB, COMP, & ODF) are logarithmically calculated from the horizontal flow sound test.

- Tested in accordance with AHRI Standard 260-2001. Refer to 2001 Standard for Sound Rating of Ducted Air Moving and Conditioning Equipment.
- Testing datum includes effect of standard inlet air filters.
- Test duct dimension: 18 in. wide x 28 in. high x 8 ft. long, no elbows.
- Test duct termination is flush with reverberant room wall.
- Duct end (sound reflection) corrections included: (7.2, 3.4, 1.2, 0.4, 0.1, 0, 0, 0) dB at (63, 125, 250, 500, 1k, 2k, 4k, 8k) Hz respectively.

#### Outdoor Sound Power Levels ZV-A3 thru -A5

Size (Tons)	Model	Sound Rating <sup>1</sup> dB (A)	Octave Band Centerline Frequency (Hz)							
			63	125	250	500	1000	2000	4000	8000
-A3 (3)	ZV	75	78.5	78.5	74.0	72.0	68.5	65.0	60.5	53.0
-A4 (4)	ZV	75	83.0	78.5	74.5	72.0	69.5	63.0	58.0	55.5
-A5 (5)	ZV	75	80.0	78.0	74.5	72.5	69.0	63.0	57.5	52.0

1. Rated in accordance with AHRI 270 standard.

## Electrical Data

### ZV-A3 thru -A5 Standard Indoor Blower - Without Powered Convenience Outlet

Size (Tons)	Volt	Compressors (each)			OD Fan Motors (each)	Supply Blower Motor	Pwr Exh Motor	Pwr Conv Outlet	Electric Heat Option				MCA <sup>1</sup> (Amps)	MCA <sup>1</sup> w/Pwr Exh (Amps)	Max Fuse <sup>2</sup> / Breaker <sup>3</sup> Size (Amps)	Max Fuse <sup>2</sup> / Breaker <sup>3</sup> Size w/ Pwr Exh (Amps)							
		RLA	LRA	MCC	FLA	FLA	FLA	FLA	Model	kW	Stages	Amps											
-A3 (3)	208	11.6	73.0	18.1	3.5	4.3	5.5	0.0	None	-	-	-	25.8	31.3	35	40							
									E03	2.3	1	6.4	25.8	31.3	35	40							
									E06	4.5	1	12.5	25.8	31.3	35	40							
									E08	6.8	1	18.9	29.0	35.8	35	40							
									E15	11.3	2	31.4	44.6	51.5	45	60							
	230	11.6	73.0	18.1	3.5	4.3	5.5	0.0	None	-	-	-	25.8	31.3	35	40							
									E03	3.0	1	7.2	25.8	31.3	35	40							
									E06	6.0	1	14.4	25.8	31.3	35	40							
									E08	9.0	1	21.7	32.4	39.3	35	40							
									E15	15.0	2	36.1	50.5	57.4	60	60							
	460	5.7	38.0	8.9	3.5	2.1	2.2	0.0	None	-	-	-	12.7	14.9	15	20							
									E03	3.0	1	3.6	12.7	14.9	15	20							
									E06	6.0	1	7.2	12.7	14.9	15	20							
									E08	9.0	1	10.8	16.2	18.9	20	20							
									E15	15.0	2	18.0	25.2	27.9	30	30							
	575	4.0	25.6	6.2	3.5	2.0	1.8	0.0	None	-	-	-	9.8	11.6	15	15							
E08									9.0	1	8.7	13.3	15.6	15	20								
E15									15.0	2	14.4	20.5	22.8	25	25								
									None	-	-	-	28.8	34.3	40	45							
E06									4.5	1	12.5	28.8	34.3	40	45								
-A4 (4)	208	14.0	83.1	21.9	3.5	4.3	5.5	0.0	None	-	-	-	28.8	34.3	40	45							
									E06	4.5	1	12.5	28.8	34.3	40	45							
									E08	6.8	1	18.9	29.0	35.8	40	45							
									E15	11.3	2	31.4	44.6	51.5	45	60							
									E20	15.0	2	41.6	57.4	64.3	60	70							
	230	14.0	83.1	21.9	3.5	4.3	5.5	0.0	None	-	-	-	28.8	34.3	40	45							
									E06	6.0	1	14.4	28.8	34.3	40	45							
									E08	9.0	1	21.7	32.4	39.3	40	45							
									E15	15.0	2	36.1	50.5	57.4	60	60							
									E20	20.0	2	48.1	65.5	72.4	70	80							
	460	6.4	41.0	10.0	3.5	2.1	2.2	0.0	None	-	-	-	13.6	15.8	20	20							
									E06	6.0	1	7.2	13.6	15.8	20	20							
									E08	9.0	1	10.8	16.2	18.9	20	20							
									E15	15.0	2	18.0	25.2	27.9	30	30							
									E20	20.0	2	24.1	32.7	35.4	35	40							
	575	4.6	33.0	7.1	3.5	2.0	1.8	0.0	None	-	-	-	10.6	12.4	15	15							
E08									9.0	1	8.7	13.3	15.6	15	20								
E15									15.0	2	14.4	20.5	22.8	25	25								
E20									20.0	2	19.2	26.6	28.8	30	30								
									None	-	-	-	31.9	37.4	40	50							
-A5 (5)	208	16.5	110.0	25.8	3.5	4.3	5.5	0.0	None	-	-	-	31.9	37.4	40	50							
									E06	4.5	1	12.5	31.9	37.4	40	50							
									E08	6.8	1	18.9	31.9	37.4	40	50							
									E15	11.3	2	31.4	44.6	51.5	45	60							
									E20	15.0	2	41.6	57.4	64.3	60	70							
									E23	18.0	2	50.0	67.8	74.7	70	80							
	230	16.5	110.0	25.8	3.5	4.3	5.5	0.0	None	-	-	-	31.9	37.4	40	50							
									E06	6.0	1	14.4	31.9	37.4	40	50							
									E08	9.0	1	21.7	32.4	39.3	45	50							
									E15	15.0	2	36.1	50.5	57.4	60	60							
									E20	20.0	2	48.1	65.5	72.4	70	80							
									E23	24.0	2	57.7	77.5	84.4	80	90							
	460	7.2	52.0	11.3	3.5	2.1	2.2	0.0	None	-	-	-	14.6	16.8	20	20							
									E06	6.0	1	7.2	14.6	16.8	20	20							
									E08	9.0	1	10.8	16.2	18.9	20	20							
									E15	15.0	2	18.0	25.2	27.9	30	30							
E20									20.0	2	24.1	32.7	35.4	35	40								
E23									24.0	2	28.9	38.7	41.5	40	45								
575	5.5	38.9	8.6	3.5	2.0	1.8	0.0	None	-	-	-	11.7	13.5	15	15								
								E08	9.0	1	8.7	13.3	15.6	15	20								
								E15	15.0	2	14.4	20.5	22.8	25	25								
								E20	20.0	2	19.2	26.6	28.8	30	30								
								E23	24.0	2	23.1	31.4	33.6	35	35								

1. Minimum Circuit Ampacity.
2. Dual Element, Time Delay Type.
3. HACR type per NEC.

## ZV-A3 thru -A5 Hi Static Indoor Blower - Without Powered Convenience Outlet

Size (Tons)	Volt	Compressors (each)			OD Fan Motors (each)	Supply Blower Motor	Pwr Exh Motor	Pwr Conv Outlet	Electric Heat Option				MCA <sup>1</sup> (Amps)	MCA <sup>1</sup> w/Pwr Exh (Amps)	Max Fuse <sup>2</sup> / Breaker <sup>3</sup> Size (Amps)	Max Fuse <sup>2</sup> / Breaker <sup>3</sup> Size w/ Pwr Exh (Amps)
		RLA	LRA	MCC	FLA	FLA	FLA	FLA	Model	kW	Stages	Amps				
-A3 (3)	208	11.6	73.0	18.1	3.5	4.3	5.5	0.0	None	-	-	-	25.8	31.3	35	40
									E03	2.3	1	6.4	25.8	31.3	35	40
									E06	4.5	1	12.5	25.8	31.3	35	40
									E08	6.8	1	18.9	29.0	35.8	35	40
	230	11.6	73.0	18.1	3.5	4.3	5.5	0.0	E15	11.3	2	31.4	44.6	51.5	45	60
									None	-	-	-	25.8	31.3	35	40
									E03	3.0	1	7.2	25.8	31.3	35	40
									E06	6.0	1	14.4	25.8	31.3	35	40
	460	5.7	38.0	8.9	3.5	2.1	2.2	0.0	E08	9.0	1	21.7	32.4	39.3	35	40
									E15	15.0	2	36.1	50.5	57.4	60	60
									None	-	-	-	12.7	14.9	15	20
									E03	3.0	1	3.6	12.7	14.9	15	20
	575	4.0	25.6	6.2	3.5	2.0	1.8	0.0	E06	6.0	1	7.2	12.7	14.9	15	20
									E08	9.0	1	10.8	16.2	18.9	20	20
									E15	15.0	2	18.0	25.2	27.9	30	30
									None	-	-	-	9.8	11.6	15	15
-A4 (4)	208	14.0	83.1	21.9	3.5	4.3	5.5	0.0	E08	9.0	1	8.7	13.3	15.6	15	20
									E15	15.0	2	14.4	20.5	22.8	25	25
									None	-	-	-	28.8	34.3	40	45
									E06	4.5	1	12.5	28.8	34.3	40	45
	230	14.0	83.1	21.9	3.5	4.3	5.5	0.0	E08	6.8	1	18.9	29.0	35.8	40	45
									E15	11.3	2	31.4	44.6	51.5	45	60
									E20	15.0	2	41.6	57.4	64.3	60	70
									None	-	-	-	28.8	34.3	40	45
	460	6.4	41.0	10.0	3.5	2.1	2.2	0.0	E06	6.0	1	14.4	28.8	34.3	40	45
									E08	9.0	1	21.7	32.4	39.3	40	45
									E15	15.0	2	36.1	50.5	57.4	60	60
									E20	20.0	2	48.1	65.5	72.4	70	80
	575	4.6	33.0	7.1	3.5	2.0	1.8	0.0	None	-	-	-	13.6	15.8	20	20
									E06	6.0	1	7.2	13.6	15.8	20	20
									E08	9.0	1	10.8	16.2	18.9	20	20
									E15	15.0	2	18.0	25.2	27.9	30	30
-A5 (5)	208	16.5	110.0	25.8	3.5	6.8	5.5	0.0	E20	20.0	2	24.1	32.7	35.4	35	40
									None	-	-	-	10.6	12.4	15	15
									E08	9.0	1	8.7	13.3	15.6	15	20
									E15	15.0	2	14.4	20.5	22.8	25	25
	230	16.5	110.0	25.8	3.5	6.8	5.5	0.0	E20	20.0	2	19.2	26.6	28.8	30	30
									None	-	-	-	34.4	39.9	45	50
									E06	4.5	1	12.5	34.4	39.9	45	50
									E08	6.8	1	18.9	34.4	39.9	45	50
	460	7.2	52.0	11.3	3.5	3.2	2.2	0.0	E15	11.3	2	31.4	47.7	54.6	50	60
									E20	15.0	2	41.6	60.5	67.4	70	70
									E23	18.0	2	50.0	71.0	77.8	80	80
									None	-	-	-	34.4	39.9	45	50
	575	5.5	38.9	8.6	3.5	2.6	1.8	0.0	E06	6.0	1	14.4	34.4	39.9	45	50
									E08	9.0	1	21.7	35.6	42.4	45	50
									E15	15.0	2	36.1	53.6	60.5	60	70
									E20	20.0	2	48.1	68.6	75.5	70	80
								E23	24.0	2	57.7	80.7	87.5	90	90	
								None	-	-	-	15.7	17.9	20	25	
								E06	6.0	1	7.2	15.7	17.9	20	25	
								E08	9.0	1	10.8	17.5	20.2	20	25	
								E15	15.0	2	18.0	26.5	29.2	30	30	
								E20	20.0	2	24.1	34.0	36.8	35	40	
								E23	24.0	2	28.9	40.0	42.8	40	45	
								None	-	-	-	12.3	14.1	15	15	
								E08	9.0	1	8.7	14.1	16.3	15	20	
								E15	15.0	2	14.4	21.3	23.5	25	25	
								E20	20.0	2	19.2	27.3	29.6	30	30	
								E23	24.0	2	23.1	32.1	34.4	35	35	

1. Minimum Circuit Ampacity.
2. Dual Element, Time Delay Type.
3. HACR type per NEC.

ZV-A3 thru -A5 Standard Indoor Blower - With Powered Convenience Outlet

Size (Tons)	Volt	Compressors (each)			OD Fan Motors (each)	Supply Blower Motor	Pwr Exh Motor	Pwr Conv Outlet	Electric Heat Option				MCA <sup>1</sup> (Amps)	MCA <sup>1</sup> w/Pwr Exh (Amps)	Max Fuse <sup>2</sup> / Breaker <sup>3</sup> Size (Amps)	Max Fuse <sup>2</sup> / Breaker <sup>3</sup> Size w/ Pwr Exh (Amps)
		RLA	LRA	MCC	FLA	FLA	FLA	FLA	Model	kW	Stages	Amps				
-A3 (3)	208	11.6	73.0	18.1	3.5	4.3	5.5	10.0	None	-	-	-	35.8	41.3	45	50
									E03	2.3	1	6.4	35.8	41.3	45	50
									E06	4.5	1	12.5	35.8	41.3	45	50
									E08	6.8	1	18.9	41.5	48.3	45	50
									E15	11.3	2	31.4	57.1	64.0	60	70
	230	11.6	73.0	18.1	3.5	4.3	5.5	10.0	None	-	-	-	35.8	41.3	45	50
									E03	3.0	1	7.2	35.8	41.3	45	50
									E06	6.0	1	14.4	35.9	42.8	45	50
									E08	9.0	1	21.7	44.9	51.8	45	60
									E15	15.0	2	36.1	63.0	69.9	70	70
	460	5.7	38.0	8.9	3.5	2.1	2.2	5.0	None	-	-	-	17.7	19.9	20	25
									E03	3.0	1	3.6	17.7	19.9	20	25
									E06	6.0	1	7.2	17.9	20.6	20	25
									E08	9.0	1	10.8	22.4	25.2	25	30
									E15	15.0	2	18.0	31.4	34.2	35	35
	575	4.0	25.6	6.2	3.5	2.0	1.8	4.0	None	-	-	-	13.8	15.6	15	20
E08									9.0	1	8.7	18.3	20.6	20	25	
E15									15.0	2	14.4	25.5	27.8	30	30	
E20									20.0	2	19.2	31.6	33.8	35	35	
E23									24.0	2	23.1	36.4	38.6	40	40	
-A4 (4)	208	14.0	83.1	21.9	3.5	4.3	5.5	10.0	None	-	-	-	38.8	44.3	50	50
									E06	4.5	1	12.5	38.8	44.3	50	50
									E08	6.8	1	18.9	41.5	48.3	50	50
									E15	11.3	2	31.4	57.1	64.0	60	70
									E20	15.0	2	41.6	69.9	76.8	70	80
	230	14.0	83.1	21.9	3.5	4.3	5.5	10.0	None	-	-	-	38.8	44.3	50	50
									E06	6.0	1	14.4	38.8	44.3	50	50
									E08	9.0	1	21.7	44.9	51.8	50	60
									E15	15.0	2	36.1	63.0	69.9	70	70
									E20	20.0	2	48.1	78.0	84.9	80	90
	460	6.4	41.0	10.0	3.5	2.1	2.2	5.0	None	-	-	-	18.6	20.8	25	25
									E06	6.0	1	7.2	18.6	20.8	25	25
									E08	9.0	1	10.8	22.4	25.2	25	30
									E15	15.0	2	18.0	31.4	34.2	35	35
									E20	20.0	2	24.1	38.9	41.7	40	45
	575	4.6	33.0	7.1	3.5	2.0	1.8	4.0	None	-	-	-	14.6	16.4	15	20
E08									9.0	1	8.7	18.3	20.6	20	25	
E15									15.0	2	14.4	25.5	27.8	30	30	
E20									20.0	2	19.2	31.6	33.8	35	35	
E23									24.0	2	23.1	36.4	38.6	40	40	
-A5 (5)	208	16.5	110.0	25.8	3.5	4.3	5.5	10.0	None	-	-	-	41.9	47.4	50	60
									E06	4.5	1	12.5	41.9	47.4	50	60
									E08	6.8	1	18.9	41.9	48.3	50	60
									E15	11.3	2	31.4	57.1	64.0	60	70
									E20	15.0	2	41.6	69.9	76.8	70	80
									E23	18.0	2	50.0	80.3	87.2	90	90
	230	16.5	110.0	25.8	3.5	4.3	5.5	10.0	None	-	-	-	41.9	47.4	50	60
									E06	6.0	1	14.4	41.9	47.4	50	60
									E08	9.0	1	21.7	44.9	51.8	50	60
									E15	15.0	2	36.1	63.0	69.9	70	70
									E20	20.0	2	48.1	78.0	84.9	80	90
									E23	24.0	2	57.7	90.0	96.9	90	100
	460	7.2	52.0	11.3	3.5	2.1	2.2	5.0	None	-	-	-	19.6	21.8	25	25
									E06	6.0	1	7.2	19.6	21.8	25	25
									E08	9.0	1	10.8	22.4	25.2	25	30
									E15	15.0	2	18.0	31.4	34.2	35	35
E20									20.0	2	24.1	38.9	41.7	40	45	
E23									24.0	2	28.9	45.0	47.7	45	50	
575	5.5	38.9	8.6	3.5	2.0	1.8	4.0	None	-	-	-	15.7	17.5	20	20	
								E08	9.0	1	8.7	18.3	20.6	20	25	
								E15	15.0	2	14.4	25.5	27.8	30	30	
								E20	20.0	2	19.2	31.6	33.8	35	35	
								E23	24.0	2	23.1	36.4	38.6	40	40	

1. Minimum Circuit Ampacity.
2. Dual Element, Time Delay Type.
3. HACR type per NEC.

ZV-A3 thru -A5 Hi Static Indoor Blower - With Powered Convenience Outlet

Size (Tons)	Volt	Compressors (each)			OD Fan Motors (each)	Supply Blower Motor	Pwr Exh Motor	Pwr Conv Outlet	Electric Heat Option				MCA <sup>1</sup> (Amps)	MCA <sup>1</sup> w/Pwr Exh (Amps)	Max Fuse <sup>2</sup> / Breaker <sup>3</sup> Size (Amps)	Max Fuse <sup>2</sup> / Breaker <sup>3</sup> Size w/ Pwr Exh (Amps)			
		RLA	LRA	MCC	FLA	FLA	FLA	FLA	Model	kW	Stages	Amps							
-A3 (3)	208	11.6	73.0	18.1	3.5	4.3	5.5	10.0	None	-	-	-	35.8	41.3	45	50			
									E03	2.3	1	6.4	35.8	41.3	45	50			
									E06	4.5	1	12.5	35.8	41.3	45	50			
									E08	6.8	1	18.9	41.5	48.3	45	50			
									E15	11.3	2	31.4	57.1	64.0	60	70			
	230	11.6	73.0	18.1	3.5	4.3	5.5	10.0	None	-	-	-	35.8	41.3	45	50			
									E03	3.0	1	7.2	35.8	41.3	45	50			
									E06	6.0	1	14.4	35.9	42.8	45	50			
									E08	9.0	1	21.7	44.9	51.8	45	60			
									E15	15.0	2	36.1	63.0	69.9	70	70			
	460	5.7	38.0	8.9	3.5	2.1	2.2	5.0	None	-	-	-	17.7	19.9	20	25			
									E03	3.0	1	3.6	17.7	19.9	20	25			
E06									6.0	1	7.2	17.9	20.6	20	25				
E08									9.0	1	10.8	22.4	25.2	25	30				
E15									15.0	2	18.0	31.4	34.2	35	35				
575	4.0	25.6	6.2	3.5	2.0	1.8	4.0	None	-	-	-	13.8	15.6	15	20				
								E08	9.0	1	8.7	18.3	20.6	20	25				
								E15	15.0	2	14.4	25.5	27.8	30	30				
												None	-	-	-	38.8	44.3	50	50
												E06	4.5	1	12.5	38.8	44.3	50	50
-A4 (4)	208	14.0	83.1	21.9	3.5	4.3	5.5	10.0	None	-	-	-	38.8	44.3	50	50			
									E06	4.5	1	12.5	38.8	44.3	50	50			
									E08	6.8	1	18.9	41.5	48.3	50	50			
									E15	11.3	2	31.4	57.1	64.0	60	70			
									E20	15.0	2	41.6	69.9	76.8	70	80			
	230	14.0	83.1	21.9	3.5	4.3	5.5	10.0	None	-	-	-	38.8	44.3	50	50			
									E06	6.0	1	14.4	38.8	44.3	50	50			
									E08	9.0	1	21.7	44.9	51.8	50	60			
									E15	15.0	2	36.1	63.0	69.9	70	70			
									E20	20.0	2	48.1	78.0	84.9	80	90			
	460	6.4	41.0	10.0	3.5	2.1	2.2	5.0	None	-	-	-	18.6	20.8	25	25			
									E06	6.0	1	7.2	18.6	20.8	25	25			
E08									9.0	1	10.8	22.4	25.2	25	30				
E15									15.0	2	18.0	31.4	34.2	35	35				
E20									20.0	2	24.1	38.9	41.7	40	45				
575	4.6	33.0	7.1	3.5	2.0	1.8	4.0	None	-	-	-	14.6	16.4	15	20				
								E08	9.0	1	8.7	18.3	20.6	20	25				
								E15	15.0	2	14.4	25.5	27.8	30	30				
								E20	20.0	2	19.2	31.6	33.8	35	35				
												None	-	-	-	44.4	49.9	60	60
-A5 (5)	208	16.5	110.0	25.8	3.5	6.8	5.5	10.0	None	-	-	-	44.4	49.9	60	60			
									E06	4.5	1	12.5	44.4	49.9	60	60			
									E08	6.8	1	18.9	44.6	51.5	60	60			
									E15	11.3	2	31.4	60.2	67.1	70	70			
									E20	15.0	2	41.6	73.0	79.9	80	80			
	230	16.5	110.0	25.8	3.5	6.8	5.5	10.0	None	-	-	-	44.4	49.9	60	60			
									E06	6.0	1	14.4	44.4	49.9	60	60			
									E08	9.0	1	21.7	48.1	54.9	60	60			
									E15	15.0	2	36.1	66.1	73.0	70	80			
									E20	20.0	2	48.1	81.1	88.0	90	90			
	460	7.2	52.0	11.3	3.5	3.2	2.2	5.0	None	-	-	-	20.7	22.9	25	30			
									E06	6.0	1	7.2	20.7	22.9	25	30			
E08									9.0	1	10.8	23.7	26.5	25	30				
E15									15.0	2	18.0	32.7	35.5	35	40				
E20									20.0	2	24.1	40.3	43.0	45	45				
575	5.5	38.9	8.6	3.5	2.6	1.8	4.0	None	-	-	-	16.3	18.1	20	20				
								E08	9.0	1	8.7	19.1	21.3	20	25				
								E15	15.0	2	14.4	26.3	28.5	30	30				
								E20	20.0	2	19.2	32.3	34.6	35	35				
								E23	24.0	2	23.1	37.1	39.4	40	40				

1. Minimum Circuit Ampacity.
2. Dual Element, Time Delay Type.
3. HACR type per NEC.

**Electric Heat Multipliers**

Voltage		kW Capacity Multipliers <sup>1</sup>
Nominal	Applied	
240	208	0.75
	230	0.92
480	460	0.92
600	575	0.92

1. Electric heaters are rated at nominal voltage. Use this table to determine the electric heat capacity for heaters applied at lower voltages.



# Typical Wiring Diagrams

## ZV-A3 thru -A5 Typical Wiring Diagrams

### Typical ZV-A3 thru -A5 Cooling Unit with Gas Heat 208/230 Volt Wiring Diagram

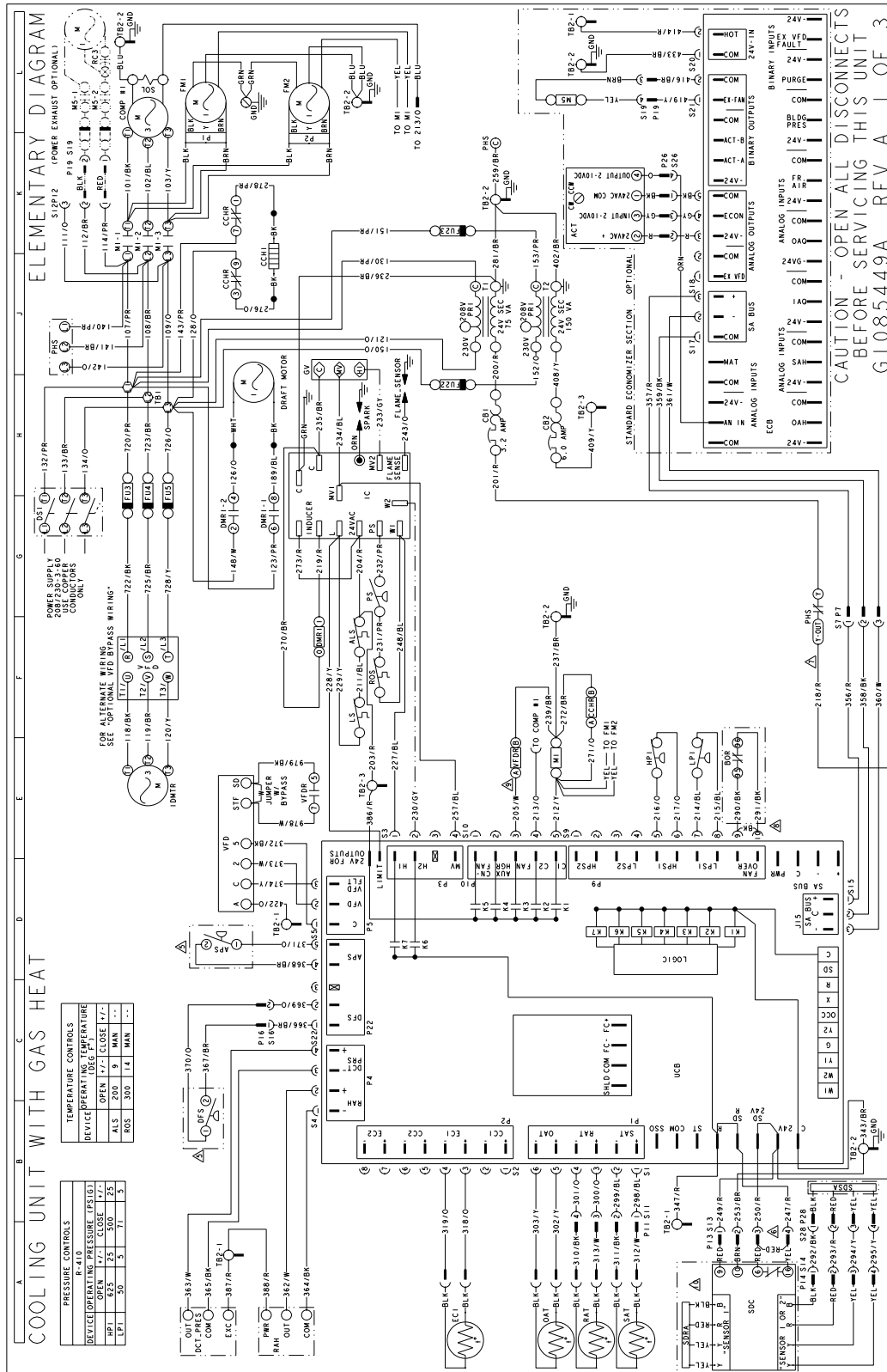

Typical ZV-A3 thru -A5 Cooling Unit with Gas Heat 208/230 Volt Unit (Options)

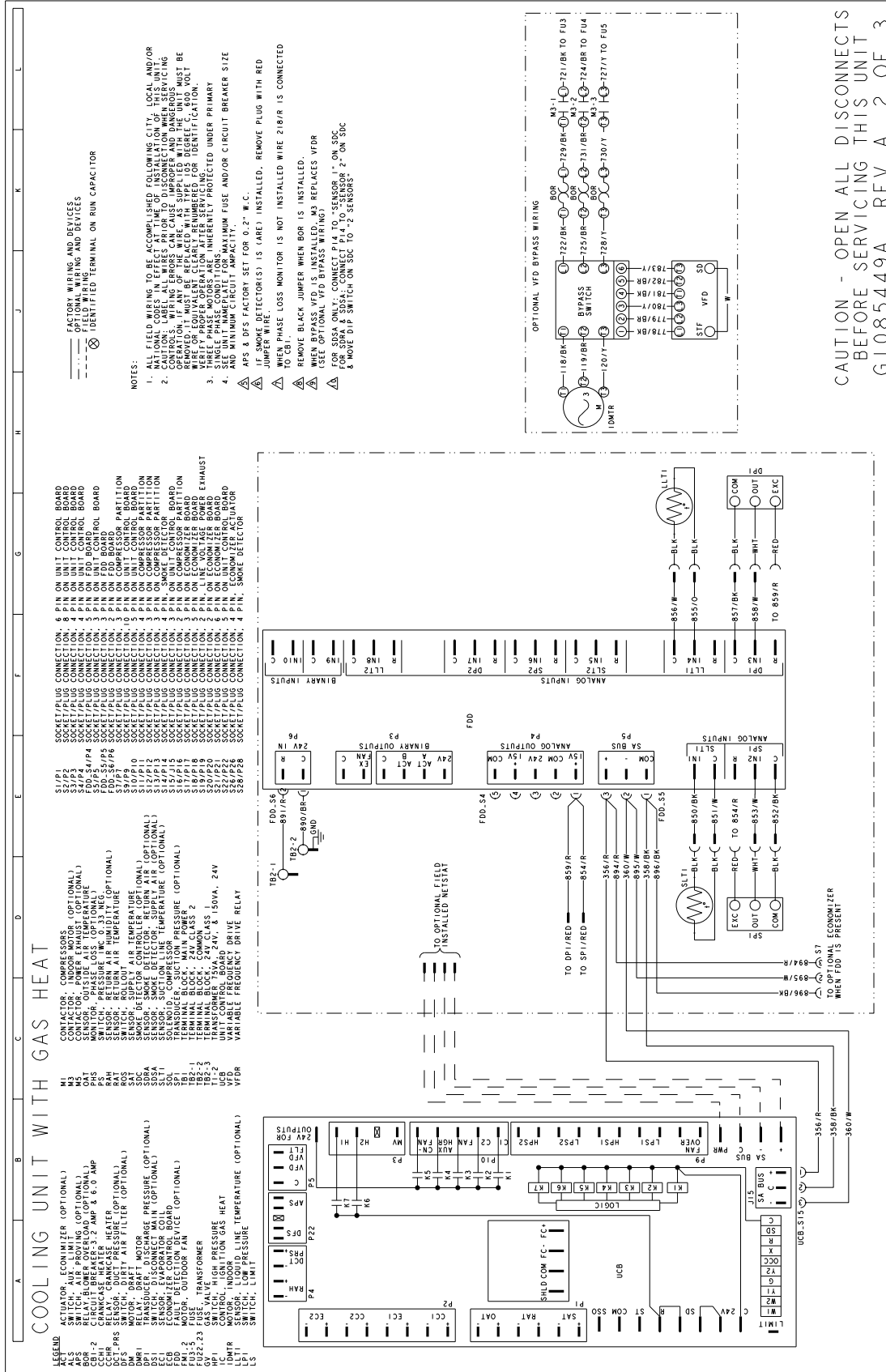

Typical ZV-A3 thru -A5 Cooling Unit with Gas Heat 460/575 Volt Wiring Diagram

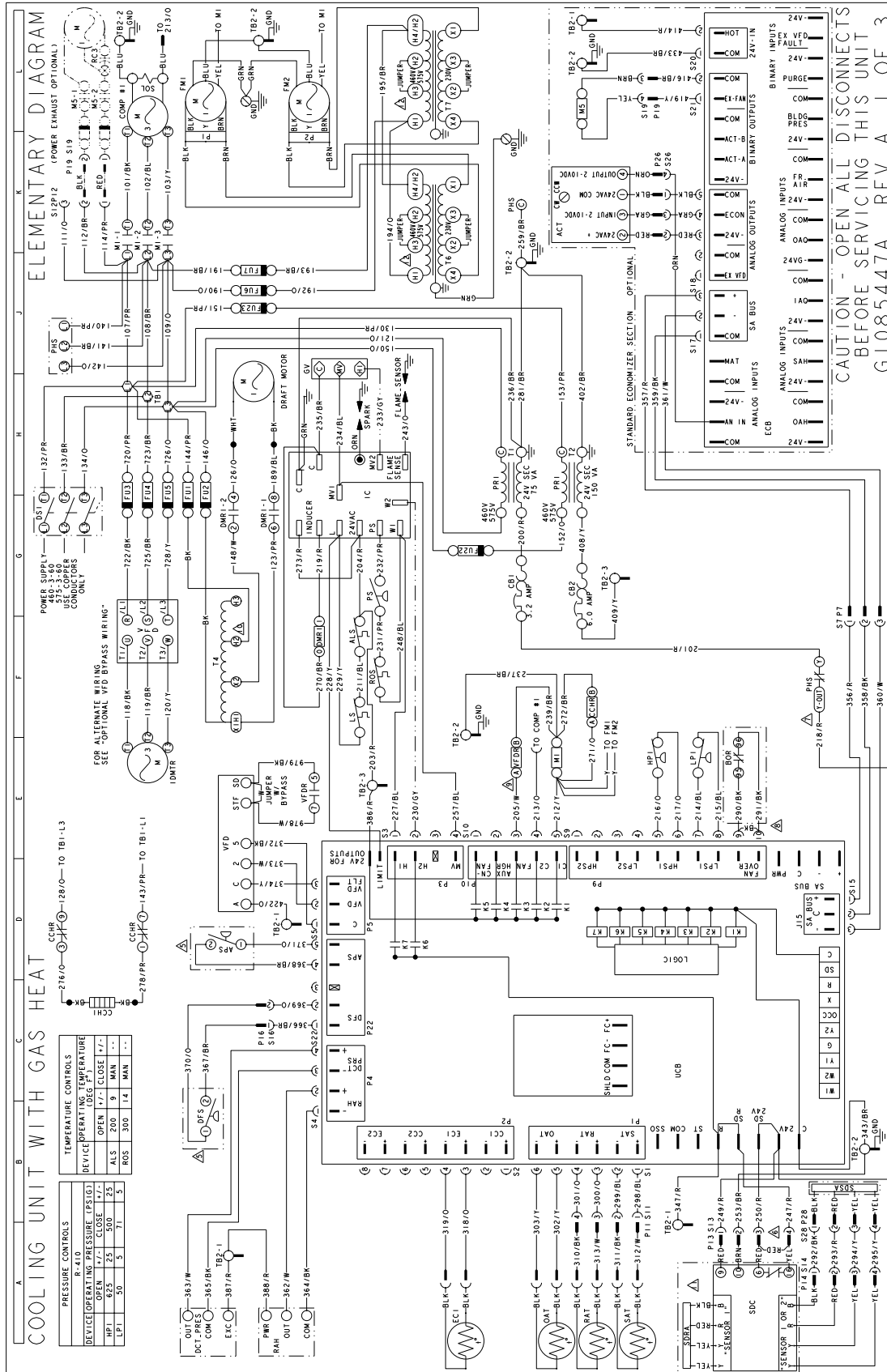





Typical ZV-A3 thru -A5 Cooling Unit with/without Electric Heat 208/230 Volt Unit

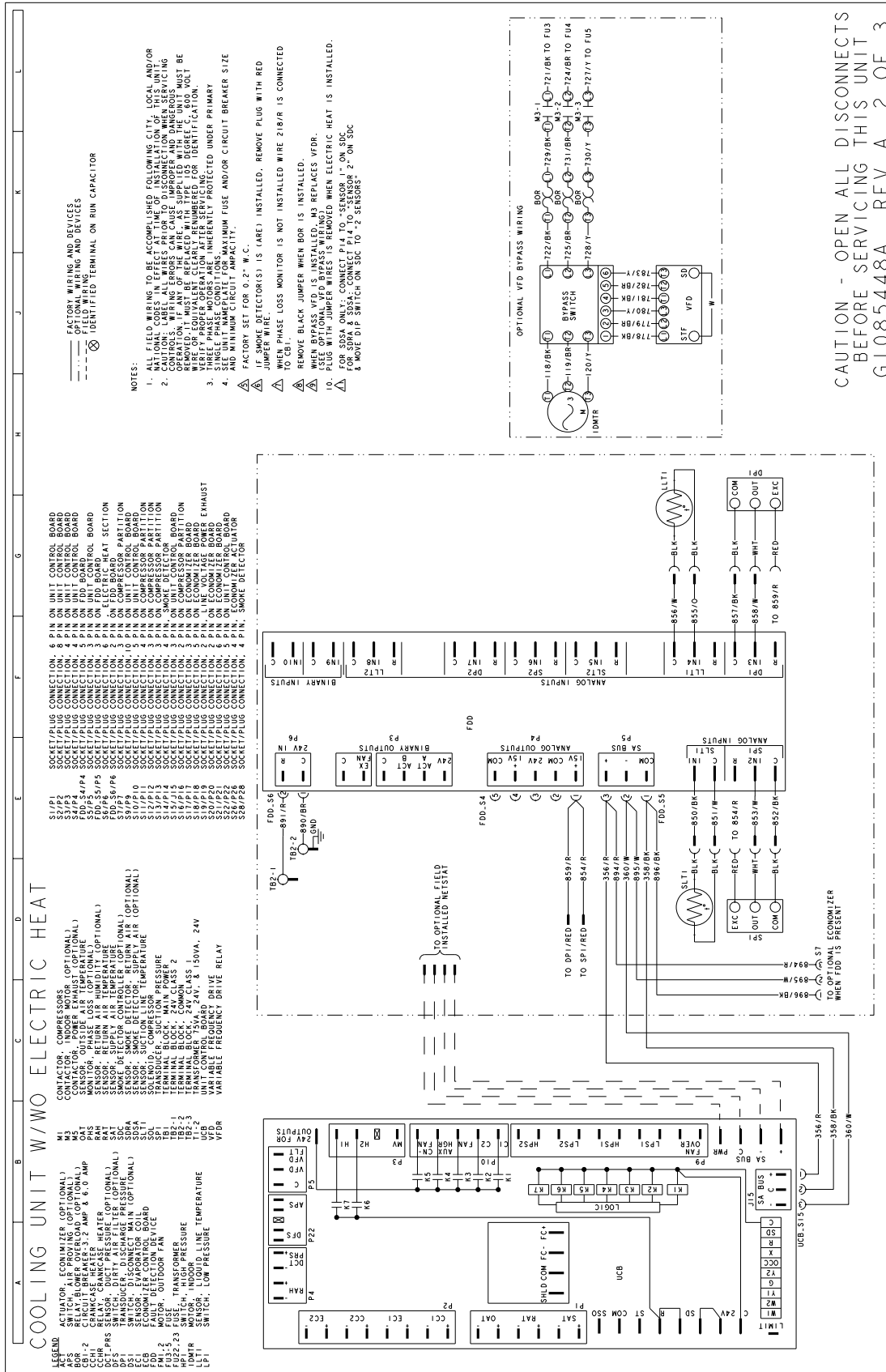

CAUTION - OPEN ALL DISCONNECTS BEFORE SERVICING THIS UNIT  
G1085448A REV A 2 OF 3

### Typical ZV-A3 thru -A5 Cooling Unit with/without Electric Heat 460/575 Volt Wiring Diagram

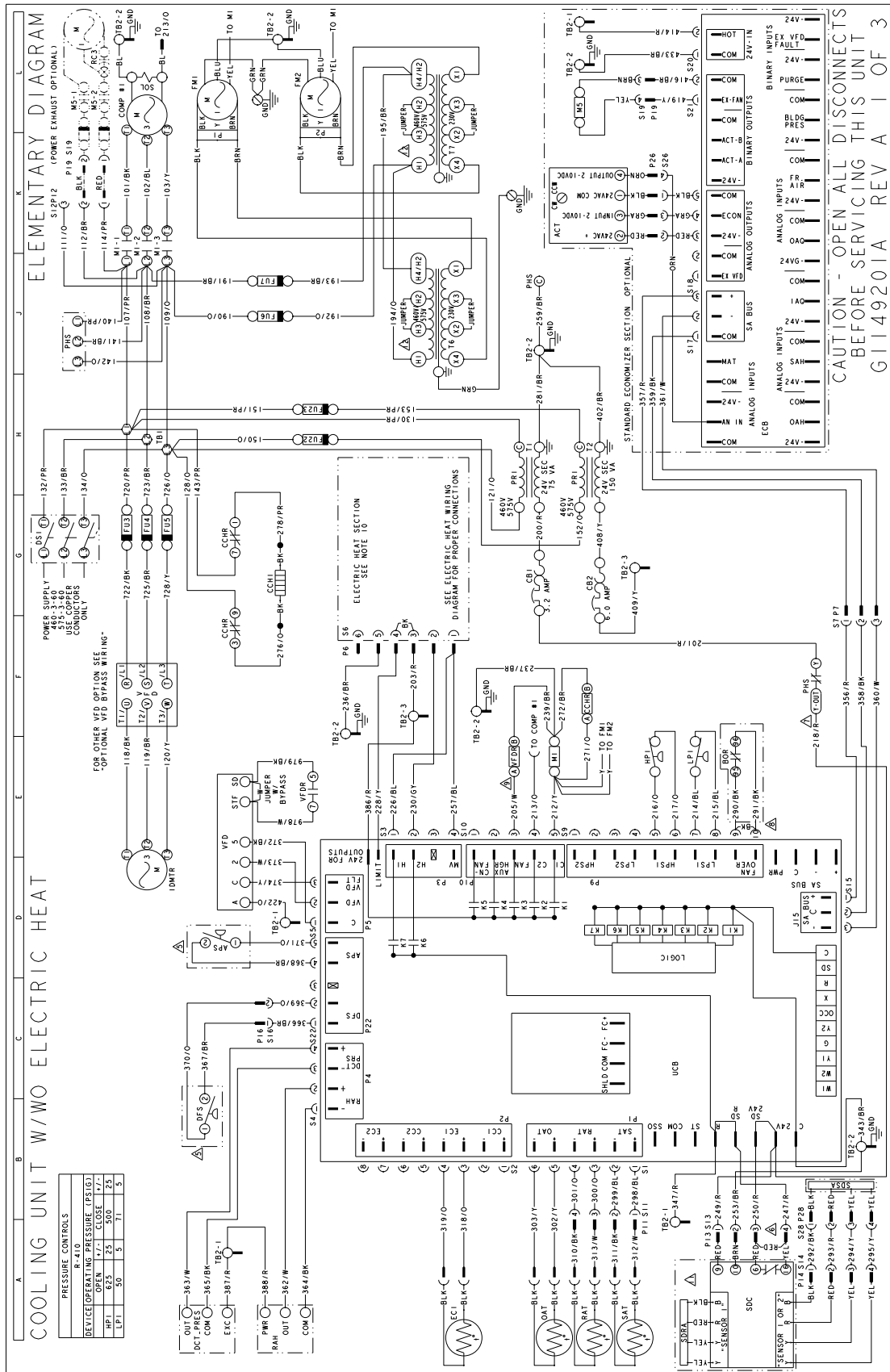







BAS Controls Typical Wiring Diagrams

Typical SURVEYOR BAS Control Wiring Diagram

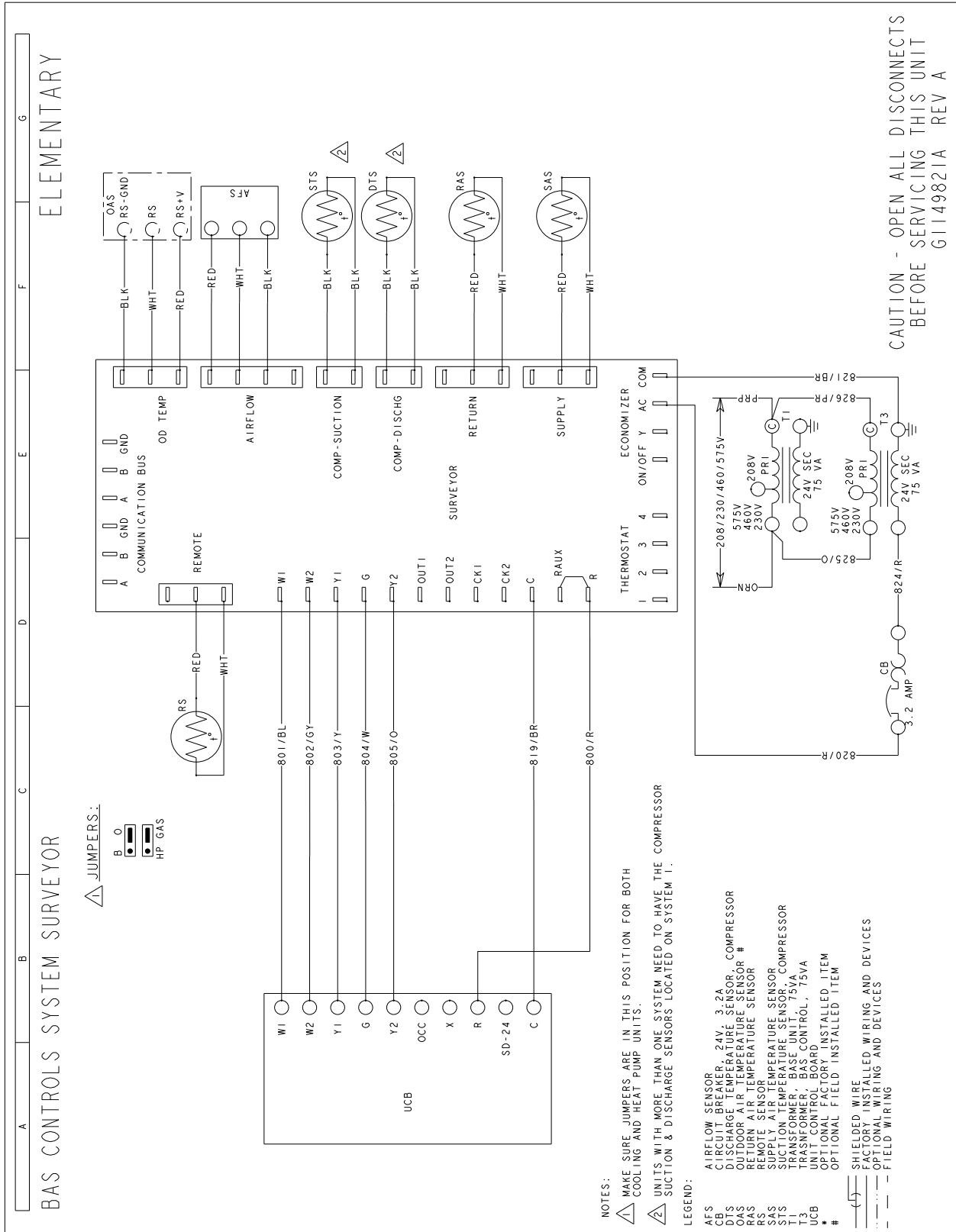

ELEMENTARY

BAS CONTROLS SYSTEM SURVEYOR

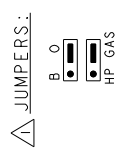

**NOTES:**

- △ MAKE SURE JUMPERS ARE IN THIS POSITION FOR BOTH COOLING AND HEAT PUMP UNITS.
- △ UNITS WITH MORE THAN ONE SYSTEM NEED TO HAVE THE COMPRESSOR SUCTION & DISCHARGE SENSORS LOCATED ON SYSTEM 1.

**LEGEND:**

- AFS AIRFLOW SENSOR
- CB CIRCUIT BREAKER, 24V, 3.2A
- DTS DISCHARGE TEMPERATURE SENSOR, COMPRESSOR
- GAS INDOOR AIR TEMPERATURE SENSOR #
- RS REMOTE SENSOR
- SAS SUPPLY AIR TEMPERATURE SENSOR
- STS SUCTION TEMPERATURE SENSOR, COMPRESSOR
- T1 TRANSFORMER, BASE UNIT, 75VA
- T3 TRANSFORMER, BAS CONTROL, 75VA
- UCB UNIT CONTROL BOARD INSTALLED ITEM
- # OPTIONAL FIELD INSTALLED ITEM
- (-) SHIELDED WIRE
- FACTORY INSTALLED WIRING AND DEVICES
- ... OPTIONAL WIRING AND DEVICES
- - - FIELD WIRING

CAUTION - OPEN ALL DISCONNECTS BEFORE SERVICING THIS UNIT  
G1149821A REV A

Typical CPC BAS Control Wiring Diagram

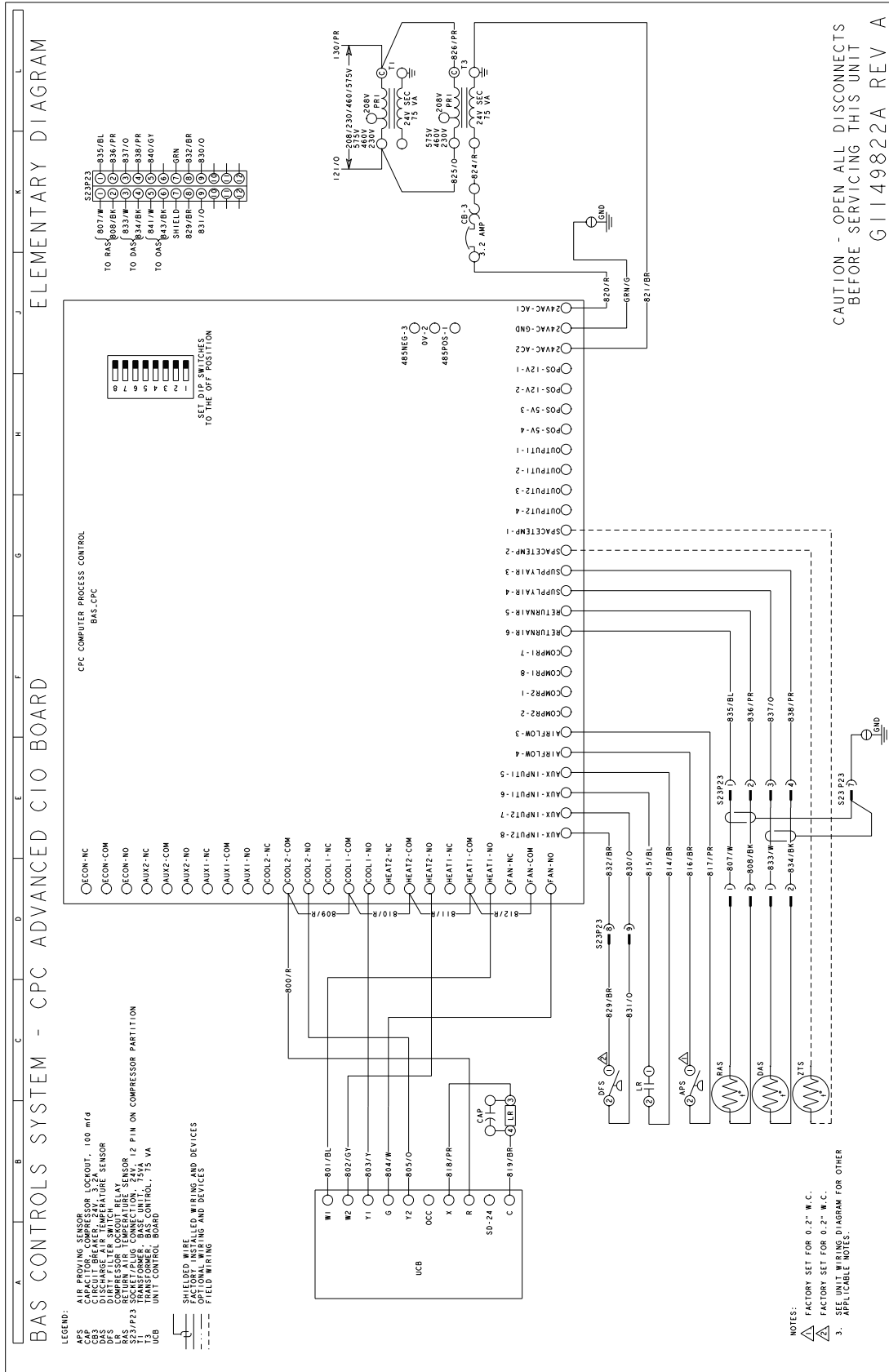

Typical HONEYWELL BAS Control Wiring Diagram

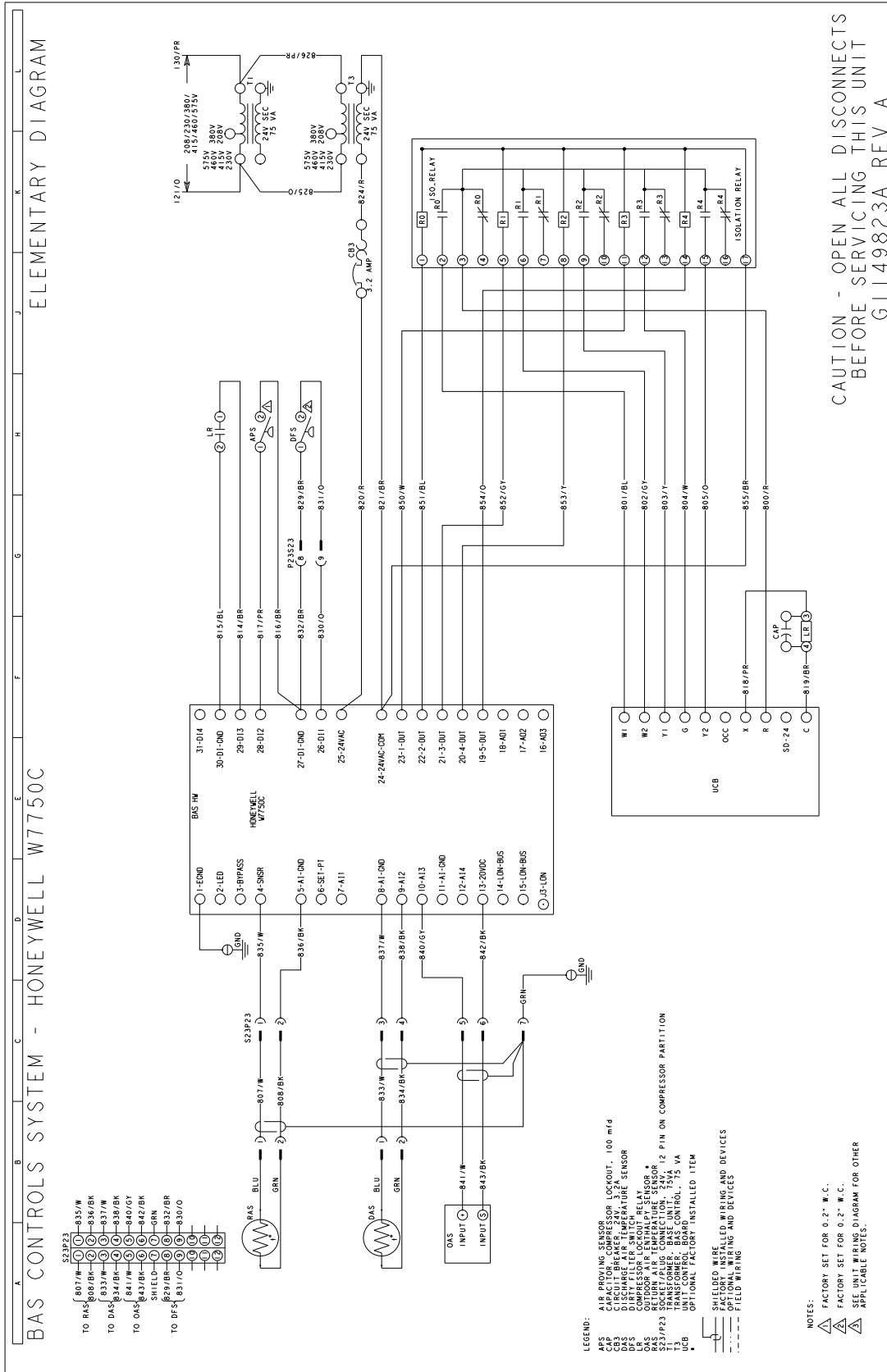

Typical HONEYWELL BAS Control Wiring Diagram

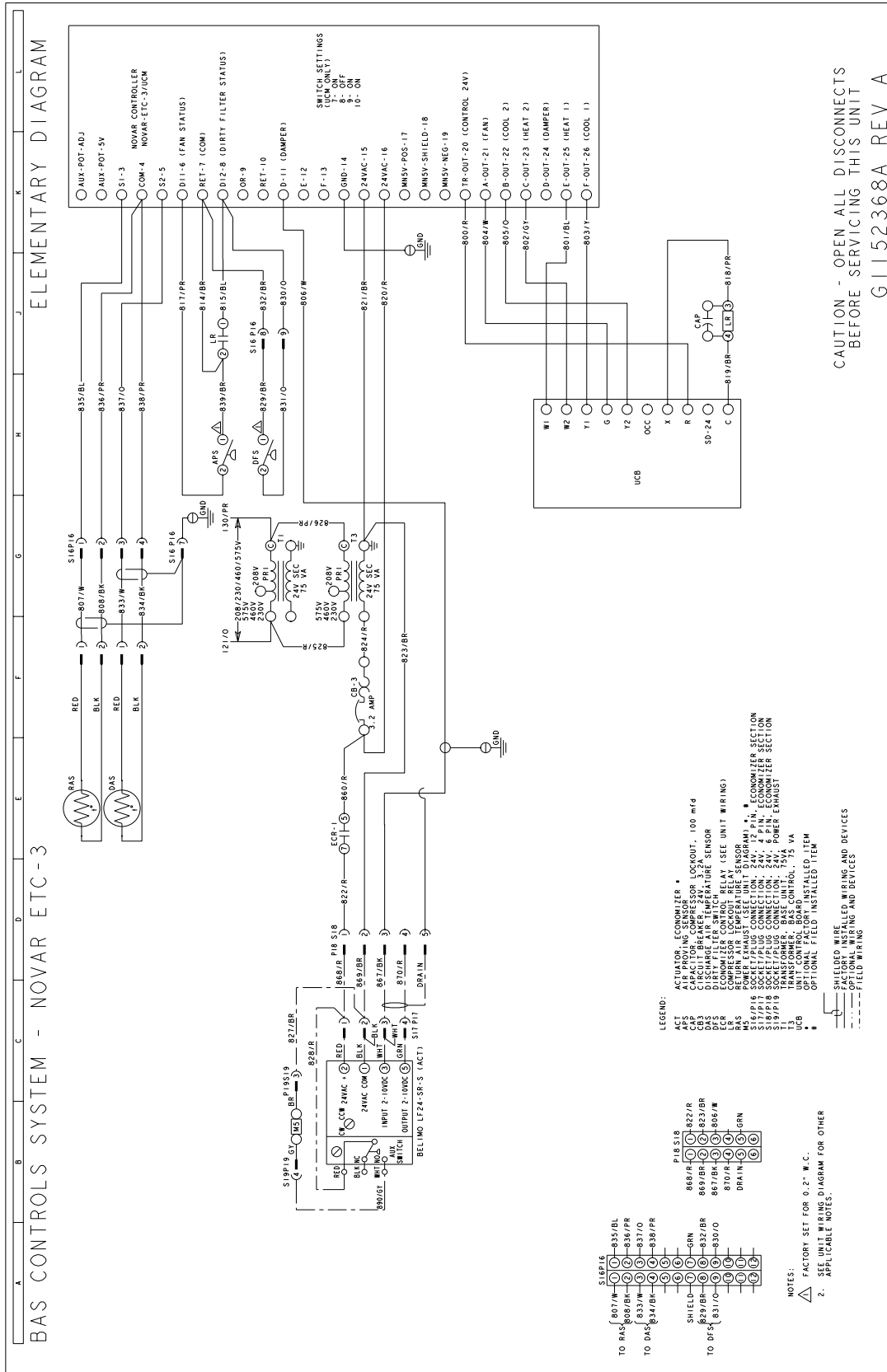

## Weights and Dimensions

### ZV-A3 thru -A5 Unit Weights

#### Unit 4 Point Load Weight

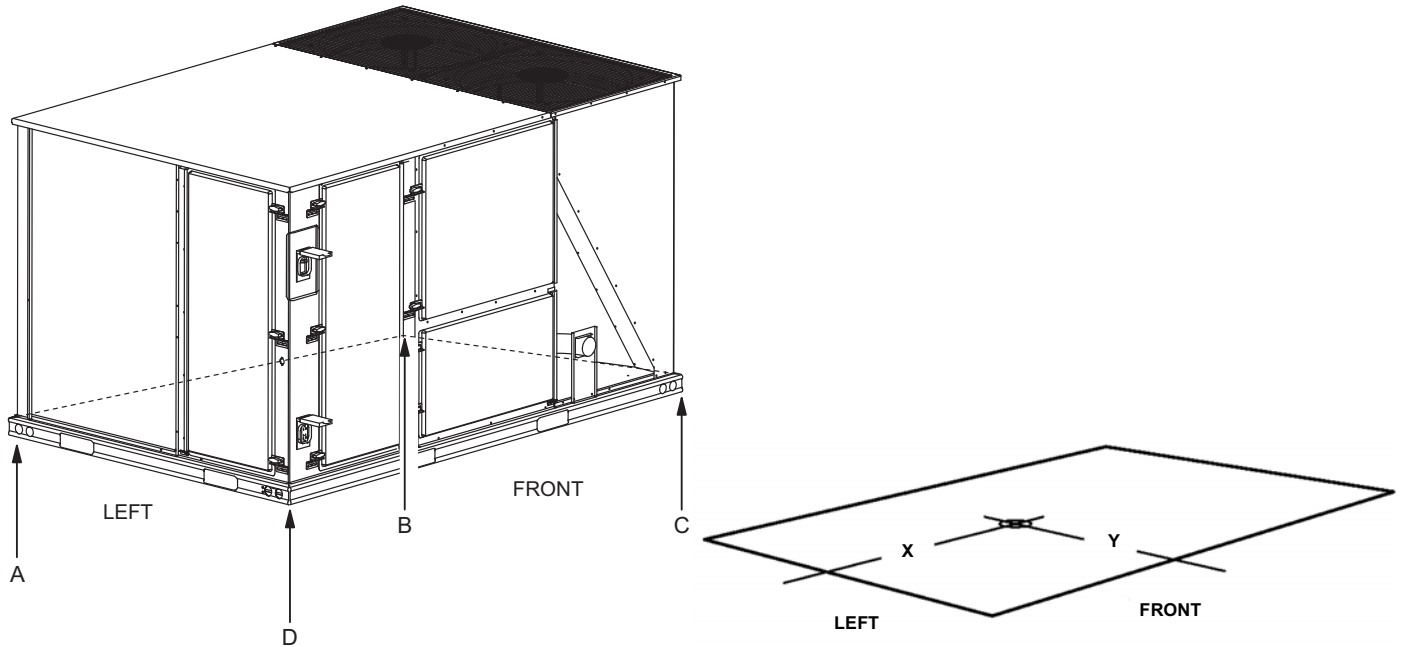

Size (Tons)	Model	Weight (lbs.)		Center of Gravity		4 Point Load Location (lbs.)			
		Shipping	Operating	X	Y	A	B	C	D
-A3 (3)	ZV	927	922	42.4	24.7	202	184	255	281
-A4 (4)	ZV	965	960	42.5	25.5	217	198	260	285
-A5 (5)	ZV	973	968	41.6	25.5	223	196	257	293

**ZV-A3 thru -A5 Unit Accessory Weights**

Unit Accessory	Weight (lbs.)	
	Shipping	Operating
Economizer	90	85
Power Exhaust	40	35
Electric Heat <sup>1</sup>	49	49
Gas Heat <sup>2</sup>	110	110
Variable Frequency Drive <sup>3</sup>	30	30

1. Weight given is for the maximum heater size available (24KW).
2. Weight given is for the maximum number of tube heat exchangers available (8 tube).
3. Weight includes mounting hardware, controls and manual bypass option (3 to 5 ton only).

**ZV-A3 thru -A5 Unit Dimensions**

ZT037 - 061

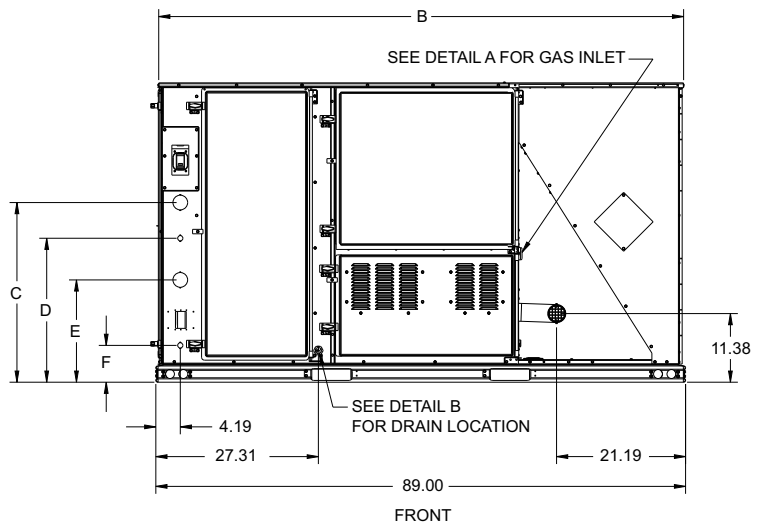
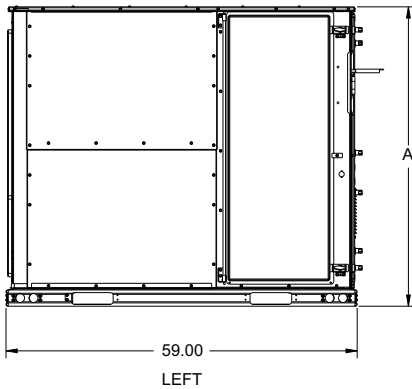
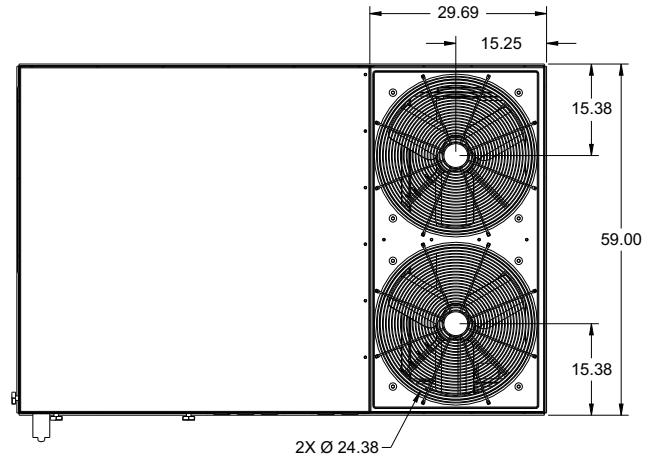

**ZV-A3 thru -A5 Unit Physical Dimensions**

Unit Model Number	Dimension (in.)					
	A	B	C	D	E	F
ZV-A3, -A4, -A5	42	89	22 1/8	18 3/16	15 3/16	6 3/16

**Detail A**

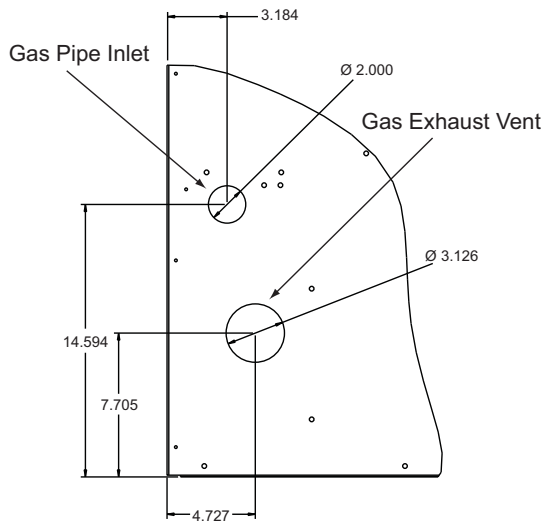

**42" CABINET**

**Detail B**

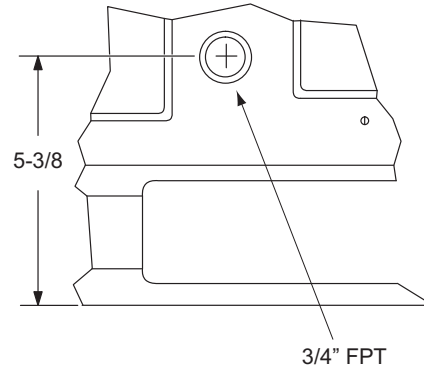

**ZV-A3 thru -A5 Unit Clearances**

Direction	Distance (in.)	Direction	Distance (in.)
Top <sup>1</sup>	72	Right	12
Front	36	Left	36
Rear	36	Bottom <sup>2</sup>	0

1. Units must be installed outdoors. Over hanging structure or shrubs should not obscure condenser air discharge outlet.
2. Units may be installed on combustible floors made from wood or class A, B or C roof covering materials.

ZV-A3 thru -A5 Unit Bottom Duct Openings

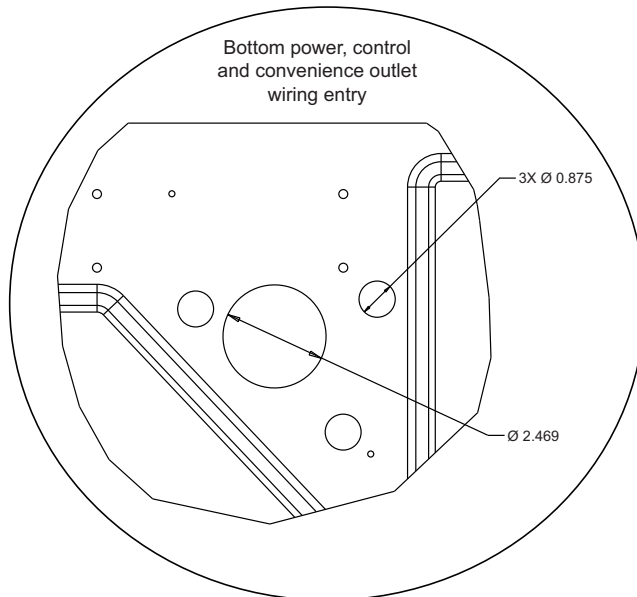
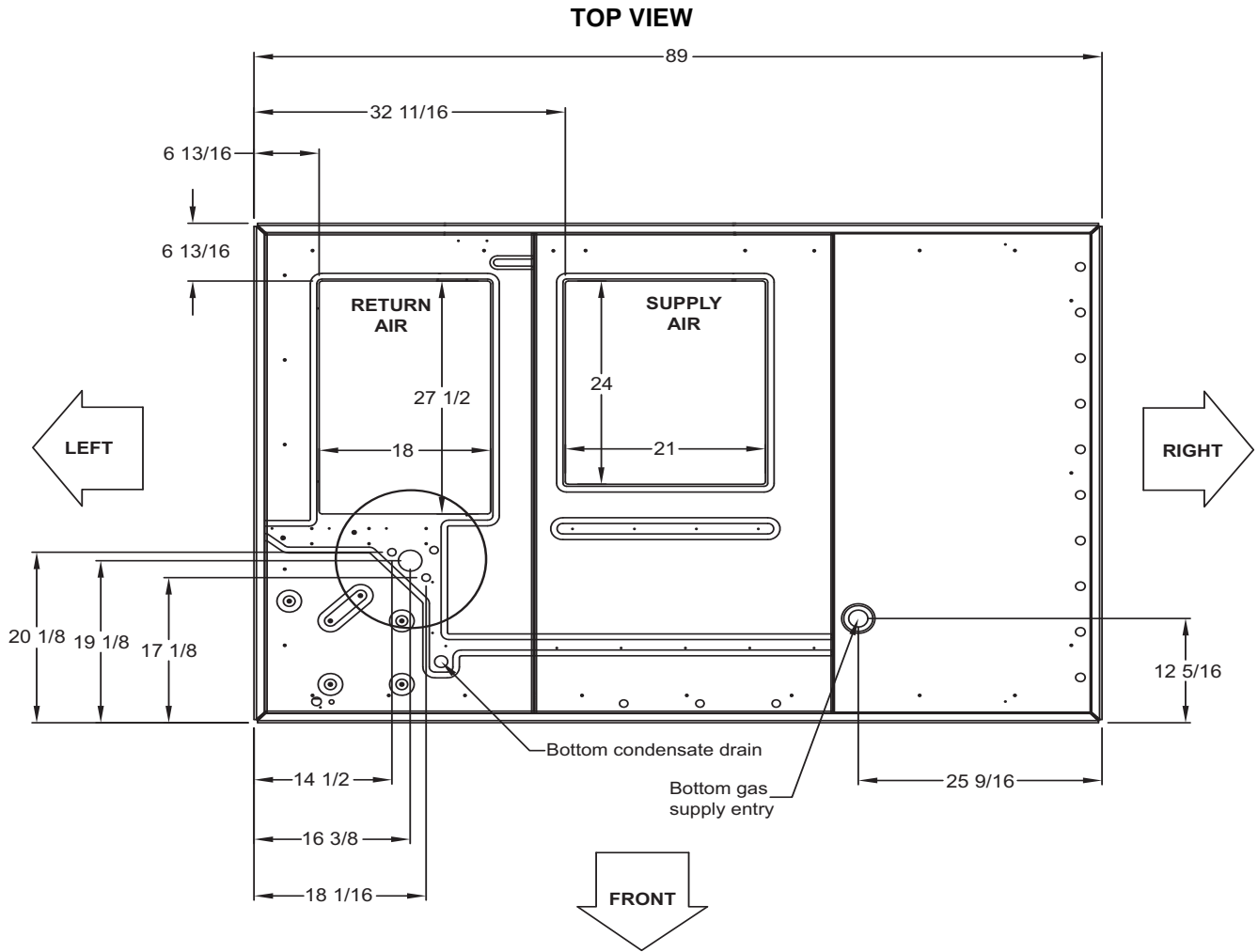



**ZV-A3 thru -A5 Unit Electrical Entry**

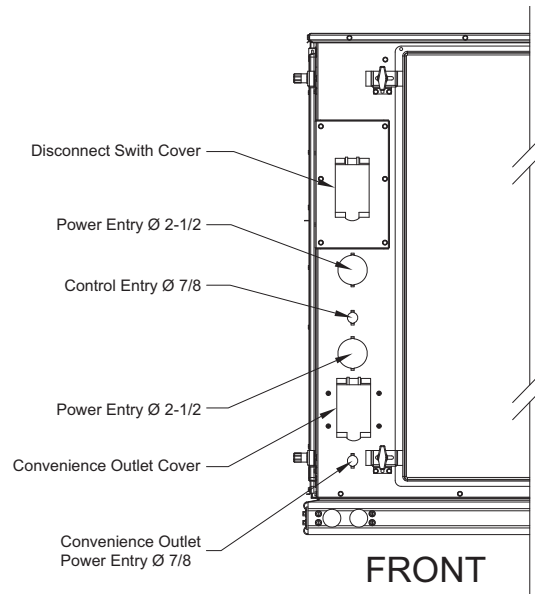

**ZV-A3 thru -A5 Unit Side Duct Openings**

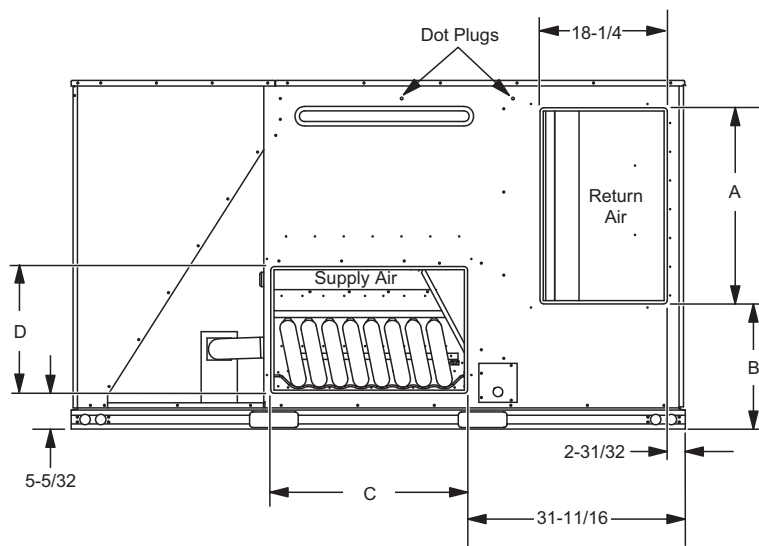

**ZV-A3 thru -A5 Side Duct Dimensions**

Unit Model Number	Dimension (in.)			
	A	B	C	D
ZV-A3, -A4, -A5	27 3/4	12 1/16	27 1/2	16

ZV-A3 thru -A5 Unit Left Duct Opening

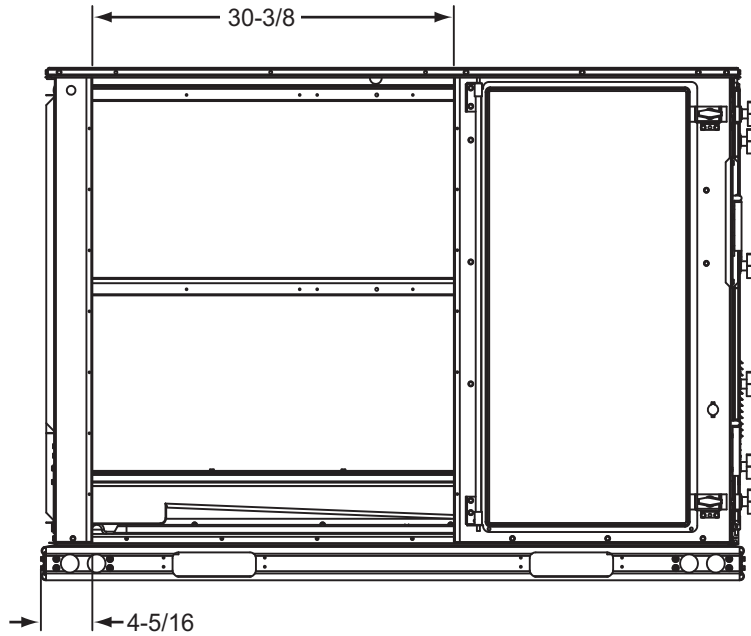

ZV-A3 thru -A5 Unit Accessory Dimensions

ZV-A3 thru -A5 Roof Curb

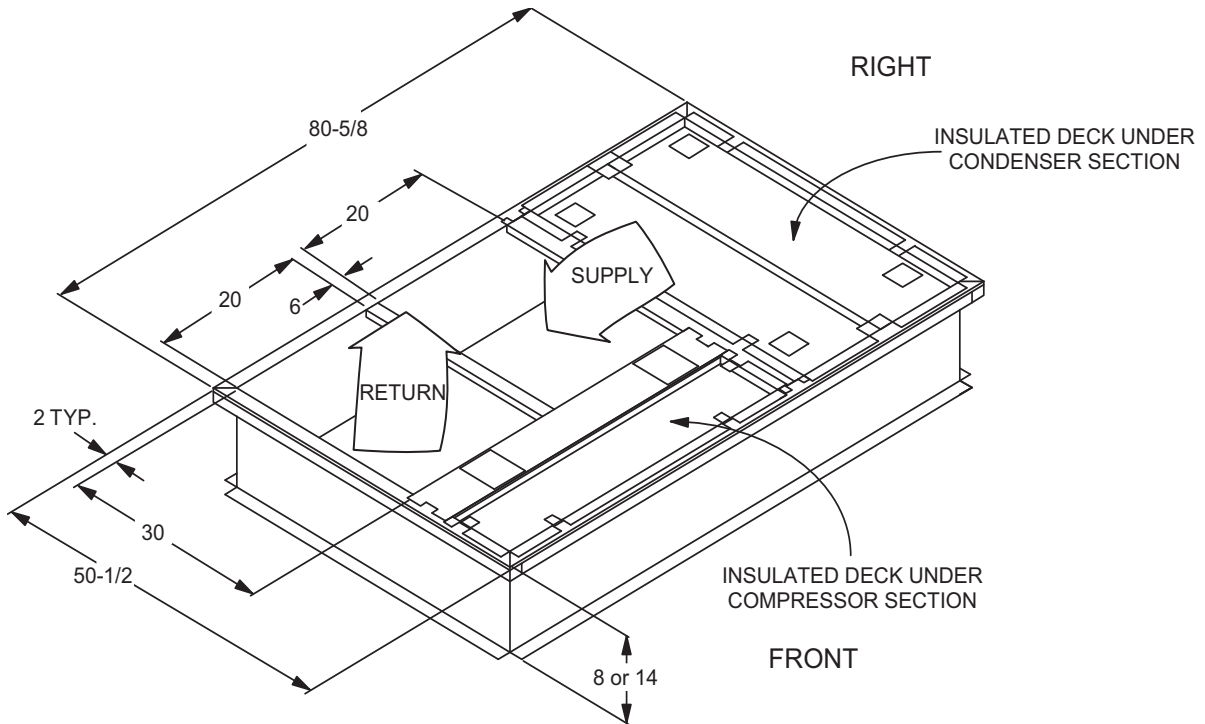

**ZV-A3 thru -A5 Transition Roof Curb**

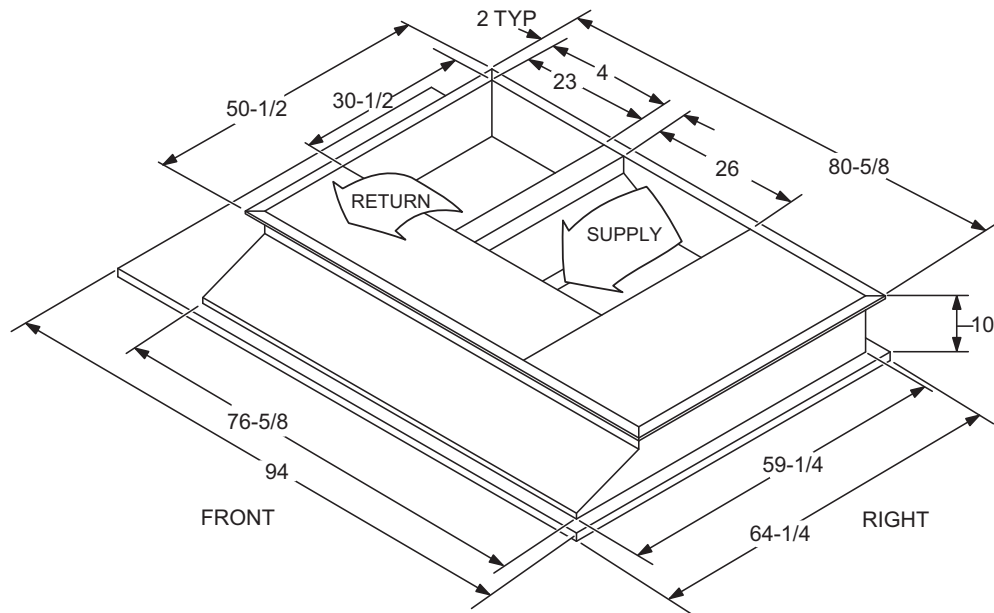

**ZV-A3 thru -A5 Roof Curb Cutaway**

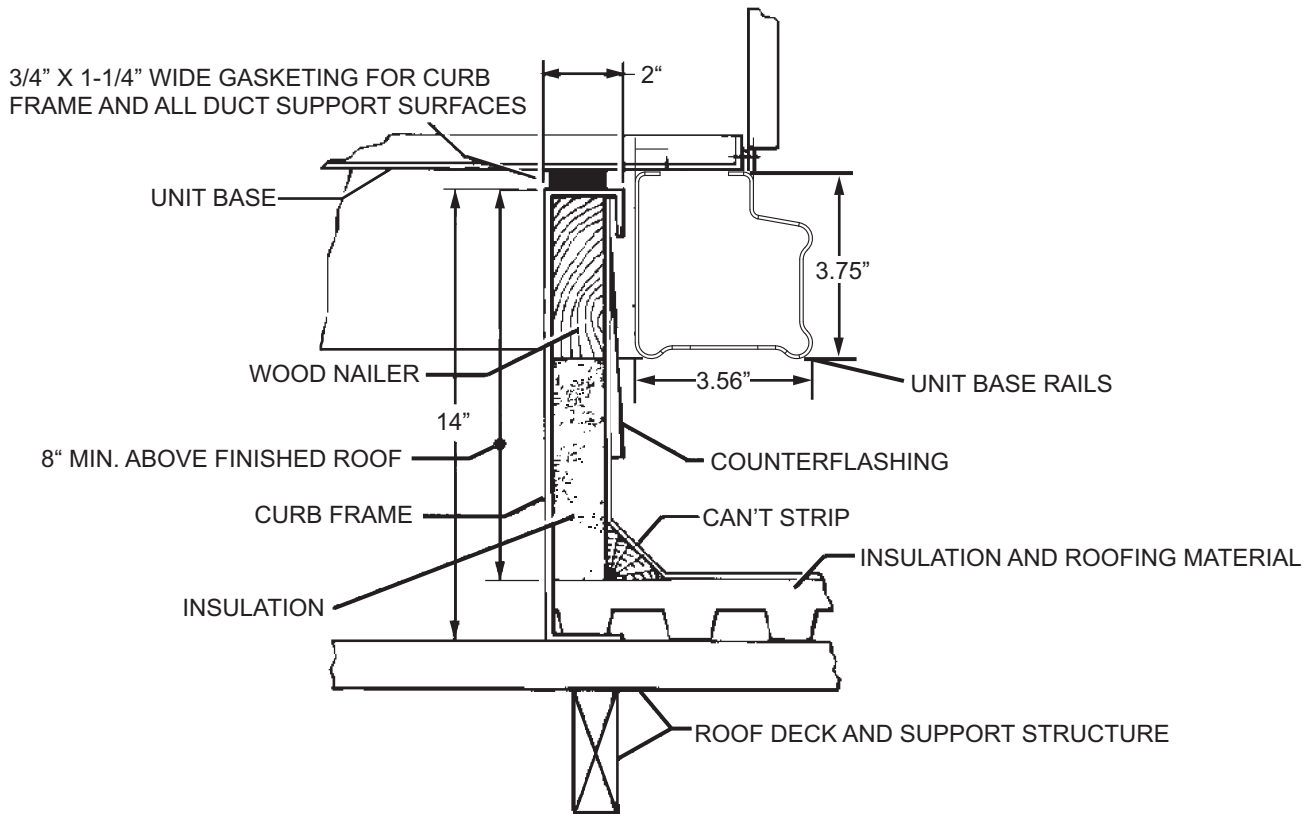

## Economizer Options

### Economizer Usage

Application	Cabinet Height	Description	Model
Side Return	All	Horizontal economizer without barometric relief	2EE04706924 <sup>1</sup>
Downflow, End Return Horizontal or ERV	42"	Economizer, 42" tall cabinet	2EE04707424 <sup>2</sup>

1. Barometric relief must be ordered separately and installed in duct work.
2. Includes fresh air hood, exhaust hood and barometric relief.

### Economizer Downflow W/Power Exhaust

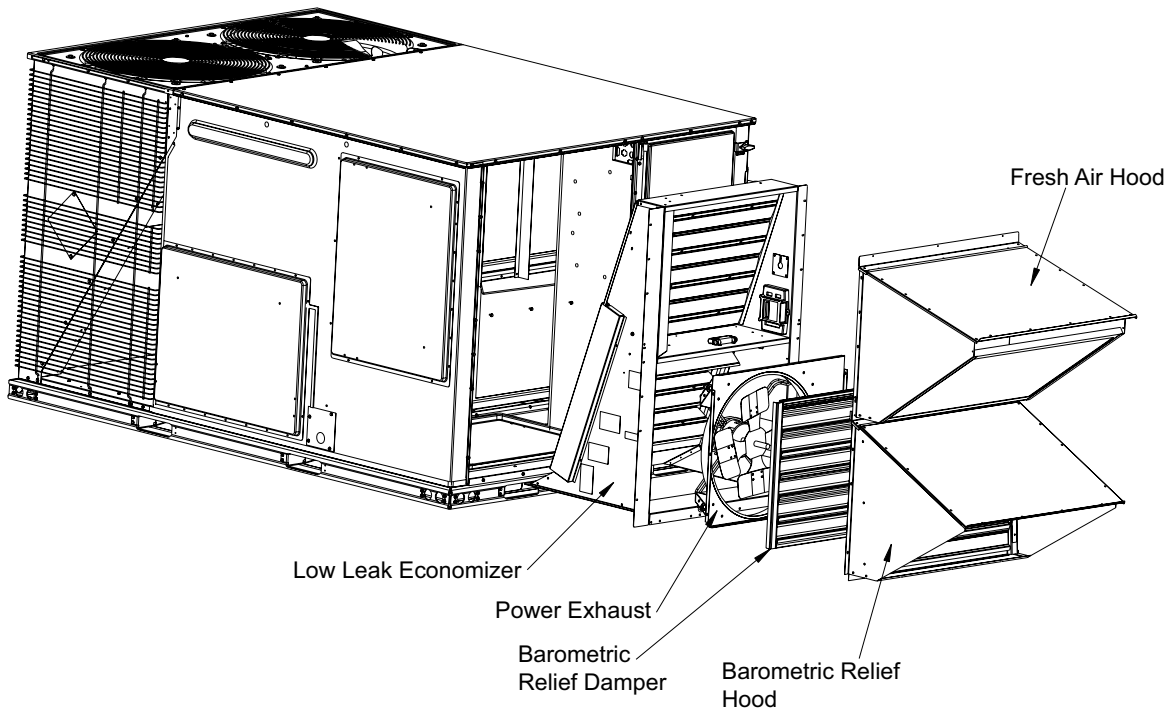

**Economizer End Return W/Power Exhaust**

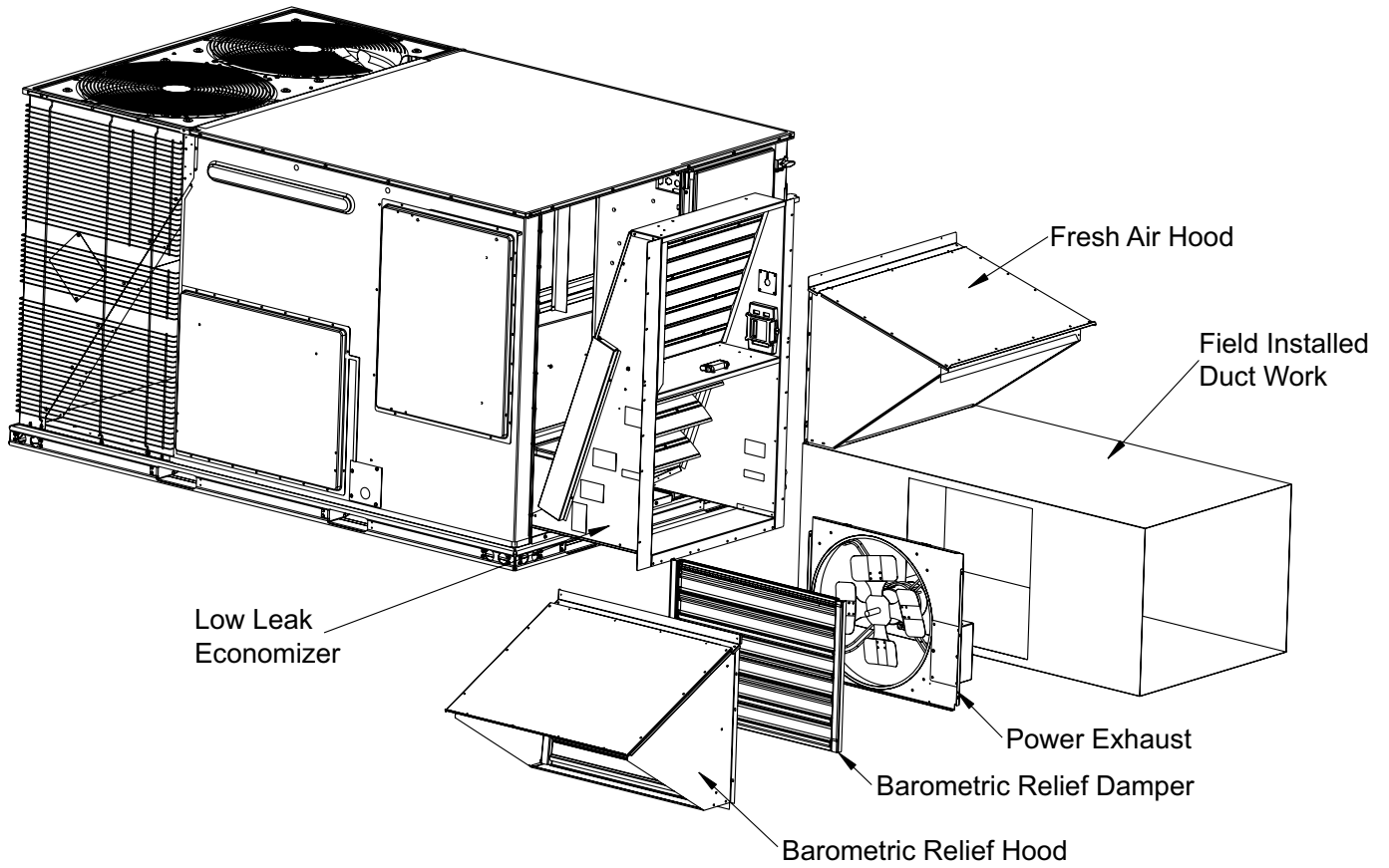

**Field Installed Horizontal Economizer W/Power Exhaust**

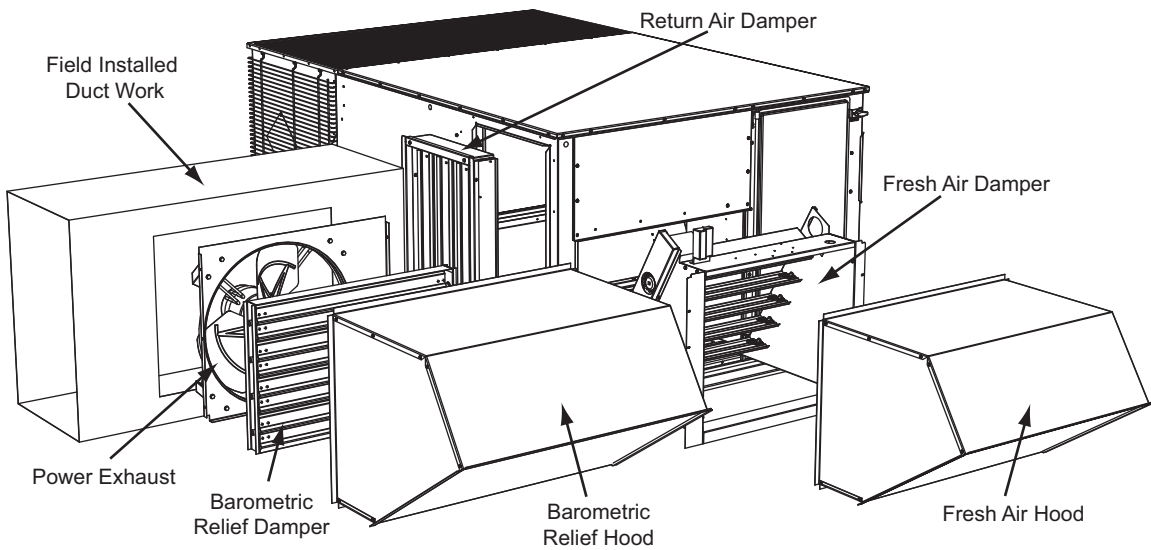

Subject to change without notice. Printed in U.S.A.  
Copyright © 2014 by Johnson Controls, Inc. All rights reserved.

1041166-BTG-D-1014  
Supersedes: 1041166-BTG-C-0614

---

**York International Corporation**  
5005 York Drive  
Norman, OK 73069