

ACCESSORY KIT INSTALLATION INSTRUCTIONS

Low Ambient Accessory FOR AIR COOLED SPLIT SYSTEM AIR CONDITIONERS (LB 15/20, HB 180/240 MODELS ONLY)

GENERAL

These split-system condensing units are designed to operate at ambient temperatures down to 40°F. This accessory will insure safe operation at ambient temperatures down to 0°F. The VFD66 control monitors both refrigerant systems. It will vary the speed of the condenser fan based on the system with the highest discharge pressure. This instruction provides all the necessary information to properly field-install a low ambient accessory on the condensing units listed in Table 1. Components that are supplied in the respective accessory are listed in Table 2, and pictured in Figure 1.

Table 1: Application Data

ACCESSORY MODEL #	VOLTAGE	UNIT
2LA04702525	208/230	HB 180, HL 15
2LA04702546	460	HB 180, HL 15
2LA04702725	208/230	HB 240, HL 20
2LA04702746	460	HB 240, HL 20

Table 2: Accessory Components

ITEM	QTY.	PART NO.	DESCRIPTION
1	1 ea.	024-32028-00X ¹	VFD66X Condenser Fan Speed Control
2	2 ea.	025-37463-000	Pressure Transducer P399BAC-1CY
3	2 ea.	025-37464-000	Wire Harness Assembly WHA-P399-500C
4	1 ea.	025-37466-000	Power Wire Harness
5	2 ea.	023-20566-000	Tee Connector
6	4 ea.	021-17153-000	Screw HEX ¼-20 X 1.0
7	1 ea.	025-09848-000	Bushing
8	6 ea.	025-09607-000	Wire Tie
9	1 ea.	025-37455-000	0° Degree Switch
10 ²	2 ea.	025-37420-240	15 Ton Crankcase Heater
		025-37421-460	15 Ton Crankcase Heater
		025-37423-240	20 Ton Crankcase Heater
		025-37424-460	20 Ton Crankcase Heater

1. X Denotes Model # needed for application.
2. Crankcase Heaters supplied are dependent on accessory ordered.



FIGURE 1 - Accessory Components

WARNING

Improper installation, adjustment, service or maintenance can cause injury or property damage. Therefore, only a qualified installer or qualified service personnel should perform this conversion.

WARNING

If the unit is connected to power sources, make sure that all electrical power to the unit has been disconnected prior to servicing.

1. Disconnect electrical power to the unit.
2. Remove the condensing unit control box access panel.

WARNING

Before installing accessory, read all of this installation instruction.

3. Install condenser fan speed control in unit control box (with screws provided). Mounting holes are pre-punched

in the control panel at the position marked (VFD66) as shown on the unit connection diagram.

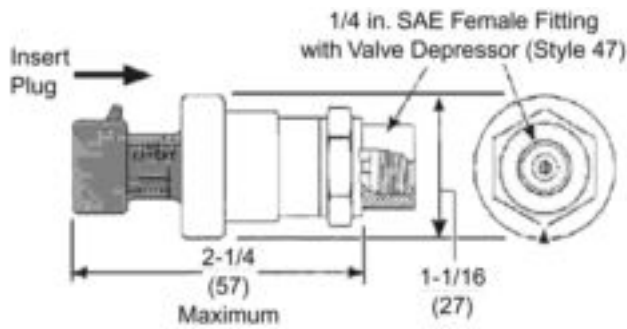

FIGURE 2 - P399 Pressure Transducer

CAUTION

Do not remove the plastic plugs from the transducers until they are ready to be installed.

4. Attach the pressure transducers to the connection tee (provided in accessory). The pressure transducer has a 1/4 In. SAE female flare with Schrader valve depressor for mounting to the tee. See Figure 2.

NOTE: Two tees are provided to insure the transducers are mounted vertically.

- Hand thread the transducer to the tee.
- Tighten and secure the connection.
- Remove the Schrader valve cap from the discharge line port (provided).
- Hand thread the tee to the discharge line port.
- Tighten and secure the connection, making sure the transducer is mounted vertically. See Figure 3.
- Perform a leak test on fittings and connections before putting the system into operation.

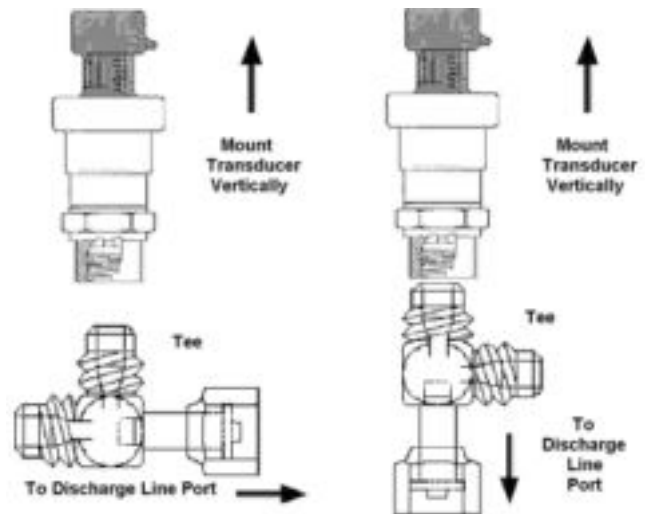

FIGURE 3 - P399 Pressure Transducer Mounting

NOTE: This procedure must be repeated for each system.

5. Attach wiring harness plug to (P399) transducer. Route sensor wires with the discharge pressure switch wires back to control box. Run wires through the bushing (provided), using knock out located near the control in the bottom of the unit control box. See Figure 4.

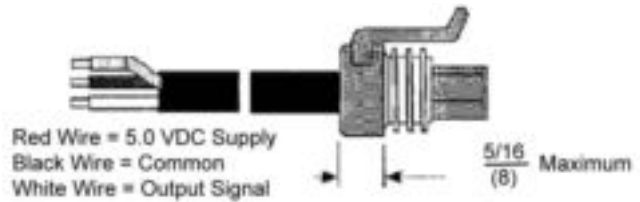

FIGURE 4 - wire harness assembly

6. Access the VFD66 control terminal blocks. See Figure 5.

- Remove the terminal access cover screws.
- Push downward on the ventilation holes while pulling outward on the top of the terminal access cover.

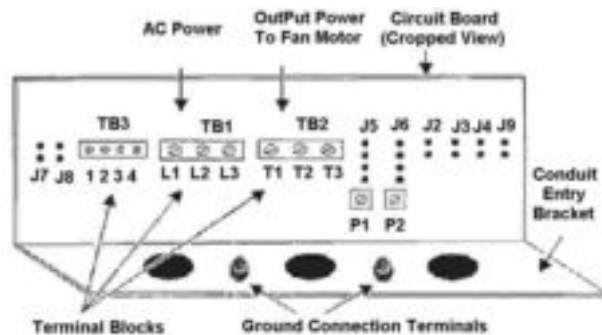

FIGURE 5 - VFD66 CONTROL TERMINAL BLOCKS

7. Wire transducers to the VFD66 control. See Figure 6.

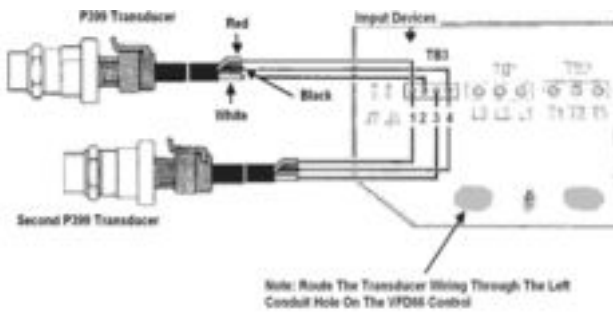

FIGURE 6 - P399 Pressure Transducer Wiring

- Cut hole in the left most bushing in the bottom of the VFD66 control. See Figure 6. Push transducer sensor wires through this bushing.
- Connect red wire from transducer #1 to terminal (1) on terminal block (TB3) located on the VFD66 Control.
- Connect black wire from transducer #1 to terminal (4) on terminal block (TB3).
- Connect white wire from transducer #1 to terminal (2) on terminal block (TB3).
- Connect bare wire from transducer #1 to the grounding terminal on ambient control.
- Connect red wire from transducer #2 to terminal (1) on terminal block (TB3).
- Connect black wire from transducer #2 to terminal (4) on terminal block (TB3).
- Connect white wire from transducer #2 to terminal (3) on terminal block (TB3).
- Connect bare wire from transducer #2 to the grounding terminal on VFD66 control.

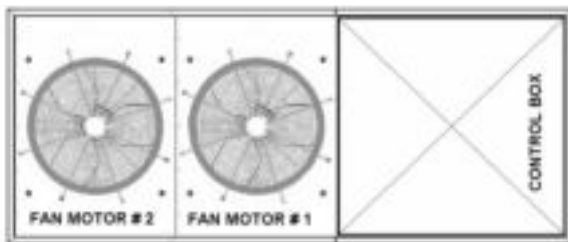

FIGURE 7 - Fan Motor #1 Location

8. Wire condenser fan motor #1 to the VFD66 control. See Figures 5, 7 and simplified wiring diagram Figure 10.

The VFD66 must be wired to operate fan motor #1. Fan motor #2 is already controlled by factory installed pressure switches.

- Disconnect wire 136/BLK from terminal (T1) on contactor (M2).
 - Disconnect wire 137/BRN from terminal (T2) on contactor (M2).
 - Disconnect wire 138/PR from terminal (T3) on contactor (M2).
 - Cut hole in the right most bushing in the bottom of the VFD66 control. Push the condenser fan motor wires through this bushing.
 - Connect wire 136/BLK to terminal (T1) on terminal block (TB2) located on the VFD66 control.
 - Connect wire 137/BRN to terminal (T2) on terminal block (TB2).
 - Connect wire 138/PR to terminal (T3) on terminal block (TB2).
 - Cut hole in the center bushing in the bottom of the VFD66 control. Push the new accessory (shielded) wires through this bushing.
 - Connect (BLK) wire of power harness to terminal (T1) on contactor (M2) and to terminal (L1) on terminal block (TB1) located on the VFD66 control.
 - Connect (RED) wire of power harness to terminal (T2) on contactor (M2) and to terminal (L2) on terminal block (TB1).
 - Connect (WHT) wire of power harness to terminal (T3) on contactor (M2) and to terminal (L3) on terminal block (TB1).
 - Connect bare wire of power harness to the grounding terminal on VFD66 control.
9. Remove existing low ambient switch (LAS) and replace with new 0°F ambient switch (provided).
10. Install additional sump heaters on compressor #1 and compressor #2. Wire each sump heater parallel to the existing heater. Ground the new crankcase heaters with the existing crankcase heater ground.
11. Check positioning of two jumpers to assure proper operation of VFD66 control. See Figure 8.

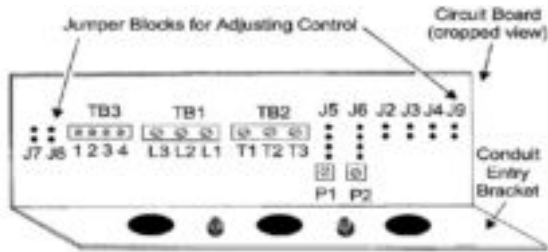

FIGURE 8 - Jumper Block Locations

- To remove a jumper, reposition the jumper so that it is connected to only one pin on the jumper block. Keep the jumper because it may be needed in the future. To install a jumper, position the jumper on both pins. See Figure 9.

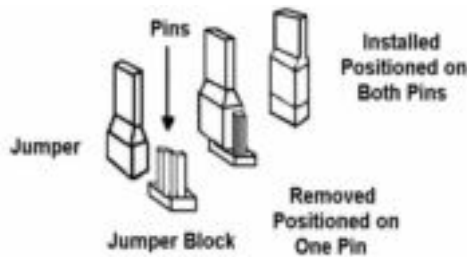

FIGURE 9 - Jumper Placement on Pins

- Jumper block (J9) selects maximum frequency output of the control. Remove the jumper for 50 Hz motors. Install the jumper for 60 Hz motors. Power must be removed and reapplied before frequency changes will have effect.
- Jumper block (J8) establishes single or dual input signal operation.

NOTE: The VFD66 is factory configured to accept single input operation.

NOTE: This application will utilize two P399 pressure transducers. Therefore, (J8) should be removed for this application. With the jumper removed the VFD66 will vary the fan speed in accordance with the higher value of the two signals received.

- Jumper blocks (J2), (J3), (J4), (J5), (J6), and (J7) are preset at the factory and cannot be field adjusted.
- The activation pressures are preset at the factory.

- Secure wiring in the unit control box in a neat workman like manner using wire ties.
- Close unit control box by replacing unit access panel and restore power to the unit.
- Verify proper unit operation.

A call for cooling closes the (M2) contactor powering the VFD66 control. As the discharge pressure rises above 210 PSI. during startup on system #1 or #2 compressor, then the VFD66 control will increase the output signal to the variable frequency drive. The drive will increase the speed of condenser fan #1 accordingly.

The scroll compressor produces a rapid rise in discharge pressure upon startup and this, depending on the ambient temperature, will result in full speed operation of condenser fan #1. After the discharge pressure has stabilized, the speed of the condenser fan #1 may decrease especially during times when the ambient temperature is below 80°F. After the #1 system has stabilized and compressor #2 is energized, usually the speed on condenser fan #1 will increase, compensating for the discharge pressure rise.

As the discharge pressure begins to fall below the 270 PSI. setpoint, the drive will reduce the speed of condenser fan #1.

As the ambient temperature drops below 40°F the #1 condenser fan will slow to the minimum speed. The #2 condenser fan will disengage when the discharge pressure drops below 180 PSIG as the ambient temperature falls. The discharge pressure of system #1 and/or #2 will increase when condenser fan #2 is disengaged.

- Contact York Technical Service for questions regarding installation.

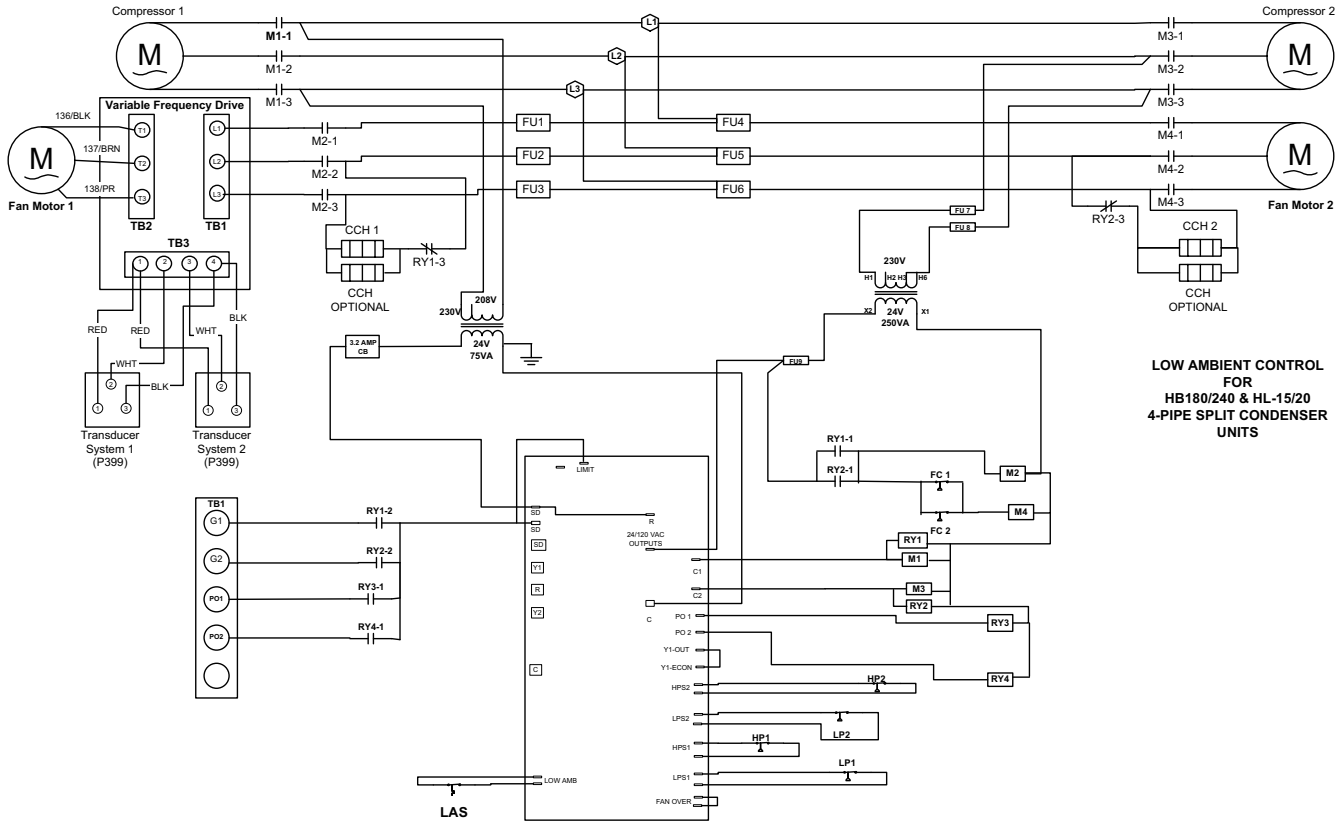

FIGURE 10 - Simplified Wiring Diagram