

40GXC / 38GXC
40GXQ / 38GXQ
Inverter-Driven High Wall Duct-Free Split System
Sizes 009 to 024



Product Data

XPOWER
INVERTER



The ideal compliment to your ducted system when it is impractical or prohibitively expensive to use ductwork.

INDUSTRY LEADING FEATURES / BENEFITS

AN INEXPENSIVE AND CREATIVE SOLUTION TO DESIGN PROBLEMS.

The 38GXC(Q)/40GXC(Q) inverter driven duct-free split systems are a matched combination of an outdoor condensing unit and an indoor fan coil unit connected only by refrigerant tubing and wires.

The fan coil is mounted on the wall, near the ceiling. This selection of fan coils permits inexpensive and creative solutions to design problems such as:

- Add-ons to current space (sun room)
- Special space requirements
- When adding air conditioning to spaces that are heated by hydronic or electric heat and have no ductwork.
- Historical renovations or any application where preserving the look of the original structure is essential.

These compact indoor fan coil units take up very little space in the room and do not obstruct windows. The fan coils are attractively styled to blend with most room decors. Advanced system components incorporate innovative technology to provide reliable cooling performance at low sound levels.

INVERTER TECHNOLOGY - COMFORT

The inverter driven compressor is designed to run at various input power frequencies (Hz) which controls the motor speed of the compressor.

Even Temperature – The control package, including the inverter, monitors outdoor and indoor temperatures as they relate to the selected indoor set point and adjusts the speed of the compressor to match the load and keep the system operating continuously rather than cycling and creating temperature swings. This translates to higher comfort levels for the occupants.

Rapid Pull Down/Warm-Up – Comfort is increased by the ability to the inverter system to ramp up the compressor speed to enabling the system to reach the user selected room temperature set point quicker.

Humidity Control – Running the system for longer periods and continuously varying the compressor speed will enhance the humidity control.

INDIVIDUAL ROOM COMFORT

Maximum comfort is provided because each space can be controlled individually based on the usage pattern. The air sweep feature provided permits optimal room mixing to eliminate hot and cold spots for the occupant comfort.

LOW SOUND LEVELS

When noise is a concern, the duct free split systems are the answer. The indoor units are whisper quiet. There are no compressors indoors, either in the conditioned space or directly over it, and there is none of the noise usually generated by air being forced through ductwork.

When sound ordinances and proximity to neighbors demand quiet operation, the 38GXQ unit is the right choice. With the inverter technology, these units run at lower speeds most of the time resulting in reduced sound levels.

INVERTER TECHNOLOGY – ENHANCED ECONOMICAL OPERATION

Duct free systems are inherently economical to operate. Individual rooms are heated or cooled only when required, and since the air is delivered directly to the space, there is no need to use additional energy to move the air in the ductwork. This economical operation is enhanced further when the inverter system output matches the load resulting in a more efficient system.

EASY-TO-USE CONTROLS

The high-wall systems have microprocessor-based controls to provide the ultimate in comfort and efficiency. The user friendly wireless remote control provides the interface between the user and the unit.

SECURE OPERATION

If security is an issue, outdoor and indoor units are connected only by refrigerant piping and wiring to prevent intruders from crawling through ductwork or wall openings. In addition since the 38GXQ can be installed close to an outside wall, coils are protected from vandals and severe weather.

FAST INSTALLATION

This compact duct-free split system is simple to install. A mounting bracket is standard with the indoor units and only wires and piping need to be run between the indoor and outdoor units. These units are fast and easy to install ensuring minimal disruption to customers in homes or workplace. This makes the 38/40GXQ systems the equipment of choice for retrofit applications.

SIMPLE SERVICING AND MAINTENANCE

Removing the top panel on outdoor units provides immediate access to the control compartment, providing a service technician access to check unit operation. In addition, the draw-thru design of the outdoor section means that dirt accumulates on the outside surface of the coil. Coils can be cleaned quickly from the inside using a pressure hose and detergent.

On all indoor units, service and maintenance expense is reduced due to easy-to-use cleanable filters. In addition, these high wall systems have extensive self-diagnostics to assist in troubleshooting.

BUILT-IN RELIABILITY

Duct-free split system indoor and outdoor units are designed to provide years of trouble-free operation.

Both the indoor and outdoor units are well protected. Whenever the microprocessor detects abnormal conditions, the unit will stop and an error code is displayed. For a complete list of abnormal conditions that are detected refer to the Safety and Reliability section in the Standard Features and Accessories on page 4.

Inverter systems provide additional reliability due to soft start. This refers to the ability of the inverter to start the compressor motor using reduced voltage and reduced current. This feature is beneficial from an electrical standpoint (eliminates current spikes) as well as an overall reliability standpoint due to reduced stress on all associated system components.

ACCESSORIES

A condensate pump accessory is available to provide installation flexibility for those applications where gravity cannot be used to dispose of the condensate.

AGENCY LISTINGS

All systems are listed with AHRI (Air conditioning, Heating, and Refrigeration Institute) and are ETL certified per UL 1995 standard.

MODEL NUMBER NOMENCLATURE

INDOOR UNIT

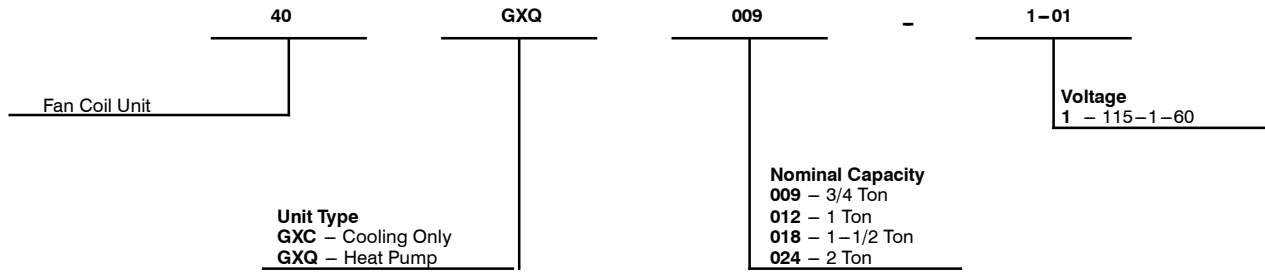

OUTDOOR UNIT

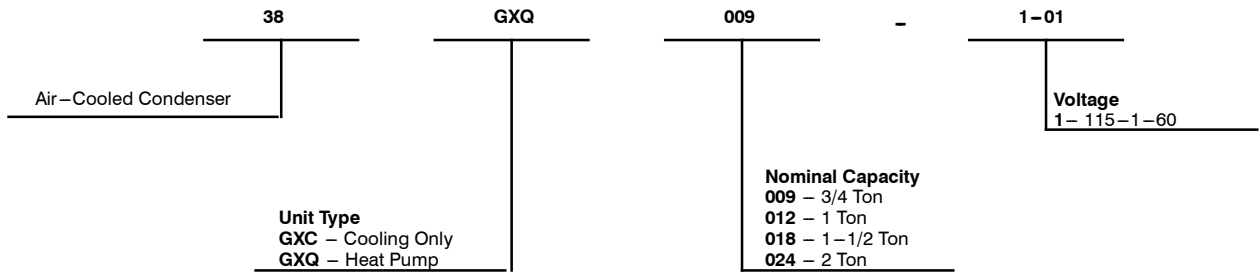

Use of the AHRI Certified TM Mark indicates a manufacturer's participation in the program. For verification of certification for individual products, go to www.ahridirectory.org.



38/40GXQ(Q)

STANDARD FEATURES AND ACCESSORIES

Ease Of Installation	
Mounting Brackets	S
Low Voltage Controls	S
Comfort Features	
Microprocessor Controls	S
Wireless Remote Control	S
Rapid Cooling/Heating	S
Automatic Air Sweep	S
Cold Blow Prevention	S
Continuous Fan *	S
Auto Restart Feature	S
Memory Function	S
Auto Changeover	S
Energy Saving Features	
Inverter Driven Compressor	S
Sleep Mode	S
24 Hour Stop/Start Timer	S
Safety And Reliability	
Indoor Unit Freeze Protection	S
3 Minute Compressor Time Delay	S
High Compressor Discharge Temperature	S
Low Voltage Protection	S
Compressor Overload Protection	S
Compressor Over current Protection	S
IPM Module Protection	S
Ease Of Service And Maintenance	
Cleanable Filters	S
Diagnostic LED's On Outdoor Board	S
Error Messages Displayed Front Panel	S
Application Flexibility	
Condensate Pump	A
Wind Baffle	F
Standard Warranty	
6 Year Compressor Limited Warranty*	S
2 Year Parts Limited Warranty*	S
Extended Warranty	
6 – 10 Year Compressor Only	O
2 – 6 Year Parts Only	O
2 – 6 Year Parts; 1–6 Yr Labor	O
2 – 6 Yr Parts; 6–10 Yr Compressor Only; 1–6 Yr Labor	O

Legend

- S Standard
- A Accessory
- O Optional
- F Field Fabricated

* For Residential applications. For Commercial applications, warranty is 1 year for parts and 5 years for compressor.

INDOOR UNITS

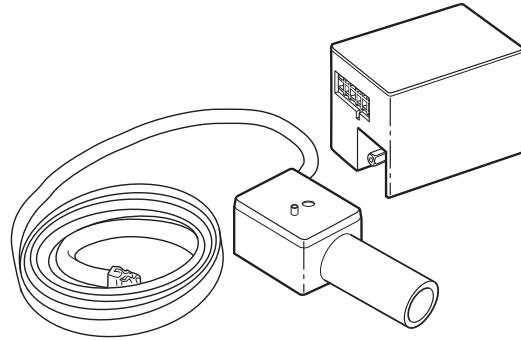

A07892

Fig. 1 – Condensate Pump Accessory

On high wall fan coils, the condensate pump accessory is recommended when adequate drain line pitch cannot be provided, or when the condensate must move up to exit.

The pump has a lift capability of 12 ft (3.6 m) on the discharge side if the pump is mounted in the fan coil or 6 ft (1.8 m) on the suction side if the pump is remote mounted.

38/40GXC(Q)

AHRI* CAPACITY RATINGS

Model Numbers		Cooling			High Heating 47°F		Low Heating 17°F
Outdoor Unit	Indoor Unit	Capacity (Btuh)	EER	SEER	Capacity (Btuh)	HSPF	Capacity (Btuh)
38GXC009---1	40GXC009---1	8,600	12.0	16.0	–	–	–
38GXC012---1	40GXC012---1	12,000	11.0	16.0	–	–	–
38GXC018---3	40GXC018---3	17,000	8.9	15.0	–	–	–
38GXC024---3	40GXC024---3	21,000	8.3	16.0	–	–	–
38GXQ009---1	40GXQ009---1	8,600	12.0	16.0	10.8	7.7	2,500
38GXQ012---1	40GXQ012---1	12,000	11.0	16.0	11,200	7.7	6,800
38GXQ018---3	40GXQ018---3	17,000	8.9	15.0	18,000	8.2	10,800
38GXQ024---3	40GXQ024---3	21,000	8.3	16.0	24,000	8.1	15,100

*Air Conditioning, Heating & Refrigeration Institute

-- = N/A

Legend

- HSPF – Heating Seasonal Performance Factor
- SEER – Seasonal Energy Efficiency Ratio

NOTES:

- Ratings are net values reflecting the effects of circulating fan heat. Ratings are based on: Cooling Standard: 80°F (26.67°C) db, 67°F (19.44°C) wb air entering indoor unit and 95°F (35°C) db air entering outdoor unit. High Temperature Heating Standard: 70°F (21.11°C) db air entering indoor unit and 47°F (8.33°C) db, 43°F (6.11°C) wb air entering outdoor unit.
- Ratings are based on 25 ft. (7.62 m) of interconnecting refrigerant lines.
- All system ratings are based on fan coil units operating at high fan speed. Consult Physical Data tables for airflows at all available fan speeds.

DIMENSIONS - INDOOR

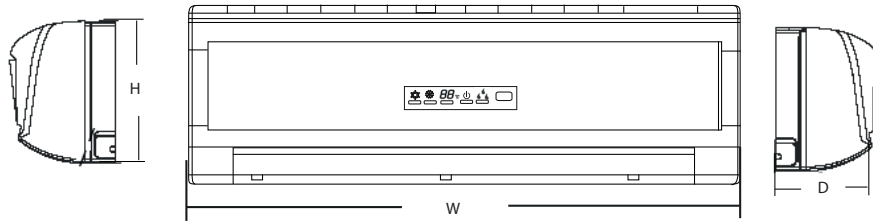

A08289

Unit Size	W In. (mm)	H In. (mm)	D In. (mm)	Net Operating Weight lb (kg)
9 K	30.3 (770)	9.8 (250)	7.84 (199)	18.7 (8.5)
12 K	32.7 (830)	11.2 (285)	8.9 (225)	24.2 (11)
18 K	32.7 (830)	11.2 (285)	8.1 (206)	26.4 (12)
24 K	42.9 (1090)	13.0 (330)	8.2 (208)	38.5 (17.5)

Fig. 2 – Dimensions of Indoor Unit

38/40GXC(Q)

DIMENSIONS - OUTDOOR

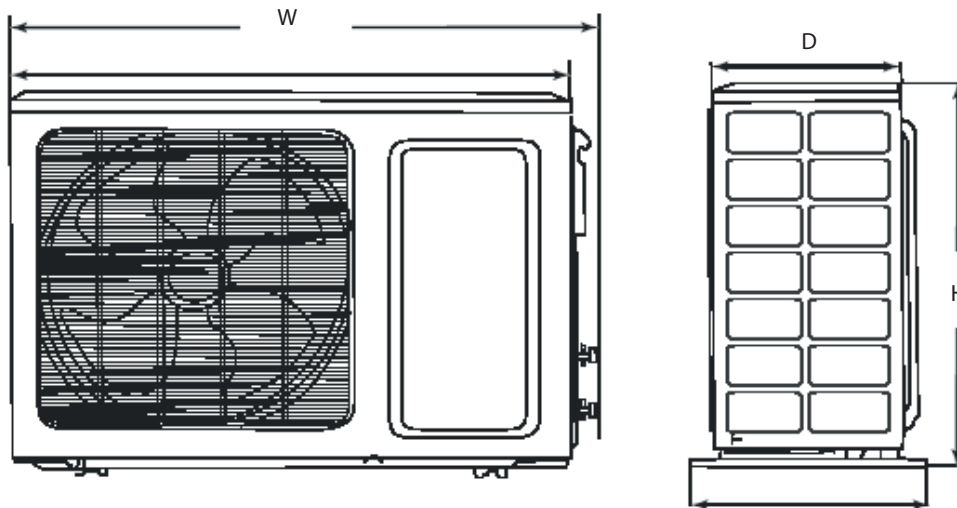

A08290

Unit Size	W In. (mm)	H In. (mm)	D In. (mm)	Net Operating Weight lb (kg)
9 K & 12 K	33.4 (848)	21.3 (540)	12.6 (320)	88.0 (40)
18 K	33.3 (846)	27.0 (685)	11.8 (300)	114.4 (52)
24 K	37.4 (950)	33.1 (840)	16.5 (420)	141.0 (64)

Fig. 3 – Dimensions of Outdoor Unit

CLEARANCES - INDOOR

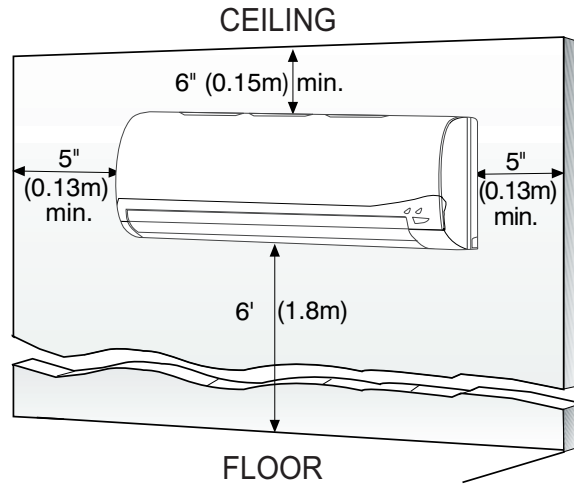

A07891

Fig. 4 – Indoor unit clearance

38/40GXC(Q)

CLEARANCES - OUTDOOR

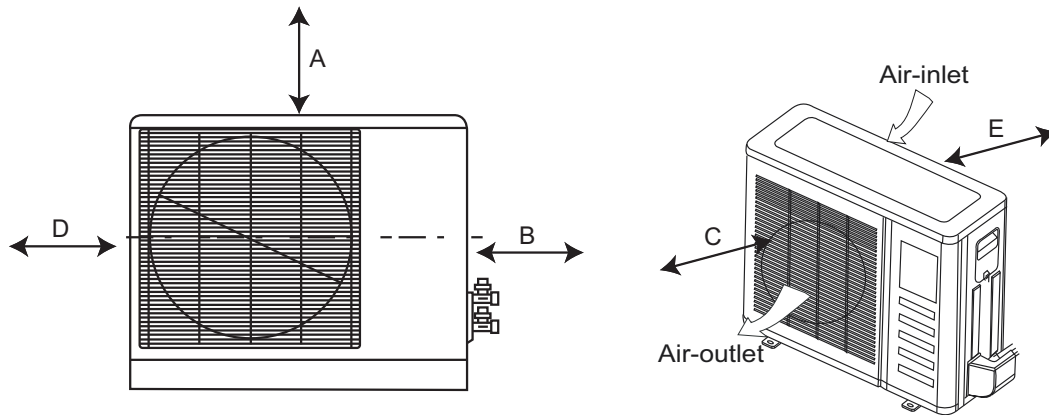

A07894

UNIT	12k in. (mm)
A	20 (508)
B	20 (508)
C	24 (610)
D	12 (305)
E	12 (305)

Fig. 5 – Outdoor Unit Clearance

PHYSICAL DATA

Outdoor Unit 38GXC(Q)	009	012	018	024
System Voltage	115-1-60		208/230-1-60	
Control Voltage	Low Voltage Pulse DC			
Rated Cooling Capacity (Btuh)	8,600	12,000	17,000	21,000
Rated Heating Capacity (Btuh)	10,800	11,200	18,000	24,000
Operating Weight lb (kg)	88 (40)		114.4 (52)	141 (64)
Refrigerant Type	R-410A			
Metering Device	Cap. Tube @ Outdoor Unit		EXV @ Outdoor Unit	
Charge lb (kg)	2.65 (1.2)	2.8 (1.27)	3.5 (1.6)	5.4 (2.5)
Compressor	Twin Rotary Inverter Driven			
Type				
Model	C-6RZ092H1AB		C-6RVN93H0N	C-6RZ146H1A
Outdoor Fan				
CFM	1060		1590	
RPM	830		780/600	
Diameter (in) ... No. of Blades	15.7 ... 3		18.1 ... 3	
Watts watts	30		60	
Outdoor Coil				
Face Area (sq.ft)	3.5		5.7	6.4
No. Rows	2			
No. of Circuits				
Fins per inch	18			
Refrigerant Lines				
Connection Type	Flare			
Liquid (Mix Phase) in OD	1/4"		3/8"	
Vapor Line in OD	1/2"		5/8"	
Maximum Length ft*	65		80	100
Max Lift (Fan Coil Above) ft	35		50	50
Max Drop (Fan Coil Below) ft	35		50	50
External Finish	White			

Indoor Unit 40GXQ	009	012	018	024
System Voltage	115 V		208/230-1-60	
Control Voltage	Low Voltage Pulse DC			
Electrical Connections	Indoor Unit Powerd From Outdoor Unit			
Rated Cooling Capacity (Btuh)	8,600	12,000	17,000	21,000
Rated Heating Capacity (Btuh)	10,800	11,200	18,000	24,000
Operating Weight lb (kg)	18.7 (8.5)	24.2 (11)	26.4 (12)	38.5 (17.5)
Refrigerant Type	R-410A			
Metering Device	Cap. Tube @ Outdoor Unit		EXV @ Outdoor Unit	
Moisture Removal Rate (pints/hr)	2.5		6.3	8.4
Indoor Fan				
RPM/CFM (Turbo)	NA	NA	1400/353	1360/471
RPM/CFM (High)	1200/290	1350/315	1260/318	1060/347
RPM/CFM (Medium)	1060/245	1200/268	1160/294	960/312
RPM/CFM (Low)	700/224	1100/245	1000/253	900/265
Motor Watts	13	20	20	35
Blower Quantity ... Size in	1 ... 3.8 x 23	1 ... 3.6 x 24.3	1 ... 3.8 x 31.4	2 ... 3.8 x 16.7
Indoor Coil				
Face Area (sq.ft)	2.4	2.4	2.9	2.6
No. Of Rows	2			
Fins Per Inch	18	18	16	18
Number Of Circuits	2	3		
Filters				
Quantity	2			
Controls	Intergrated Microprocessor			
Wireless Remote	Standard			
Modes	Cool/Heat/Dry/Auto			
Fan Mode	High/Medium/Low/Auto			
Emergency Mode	Yes			
Defrost Method	Demand Defrost			
Diagnostics	Yes			
Air Sweep	Yes			
Soft Start	Yes			
Rapid Cooling/Heating	Yes			
Cold Blow Prevention	Yes			
Sleep Mode	Yes			
24 Hour Timer	Yes			
Auto Restart	Yes			
Freeze Protection On Indoor Unit	Yes			
Refrigerant Lines				
Connection Type	Flare			
Liquid (Mix Phase) in OD	1/4"		1/2"	
Vapor Line in OD	1/2"		5/8"	
Maximum Length ft*	65		80	100
Max Lift (Fan Coil Above) ft	35		50	50
Max Drop (Fan Coil Below) ft	35		50	50
Condensate Drain				
Size in	ID = 1/2" OD = 5/8"			
External Finish	White			

* For Heat Pump models

** Refer to Long Line Application section on page 9

38/40GXC(Q)

APPLICATION DATA

UNIT SELECTION

When selecting a variable speed system match the system capacity range to the anticipated load range.

Since a variable speed system can accommodate a wide range of loads it is important to understand the percentage of time that the

system will be required to run at the both the maximum and the minimum load points.

If it is anticipated that the system will be required to run at the maximum load point for the majority of the time, the next larger system capacity should be selected.

38/40GXC(Q)

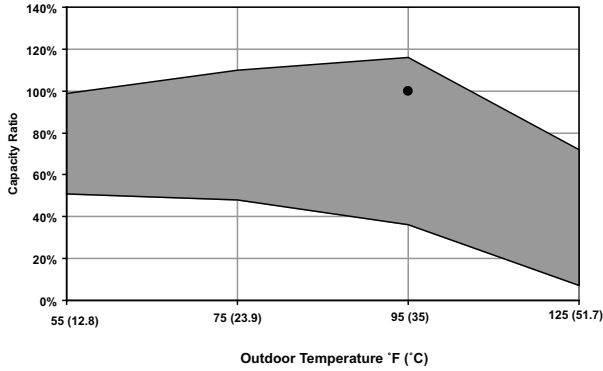

Indoor Temp. 80/67°F (26.7/19.4°C) (db/wb) – Indoor Fan High Speed
● = Rating Point

A09176

Fig. 6 – 38GXC(Q)009 / 40GXC(Q)009 Cooling

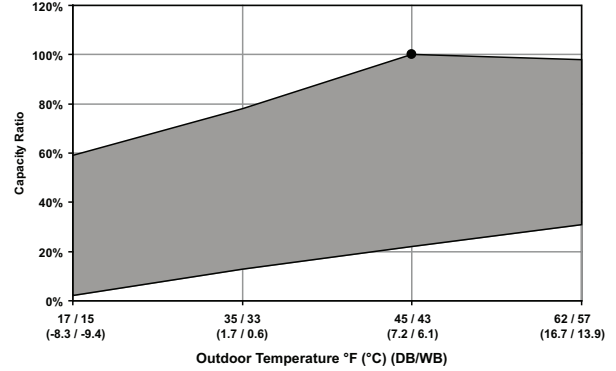

Indoor temperature 75°F (23.4°C) (db) – Indoor Fan High Speed
● = Rating Point

A09178

Fig. 7 – 38GXQ009 / 40GXQ009 Heating

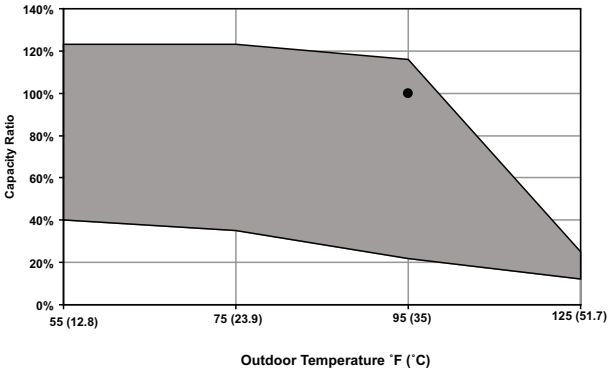

Indoor Temp. 80/67°F (26.7/19.4°C) (db/wb) – Indoor Fan High Speed
● = Rating Point

A09177

Fig. 8 – 38GXC(Q)012 / 40GXC(Q)012 Cooling

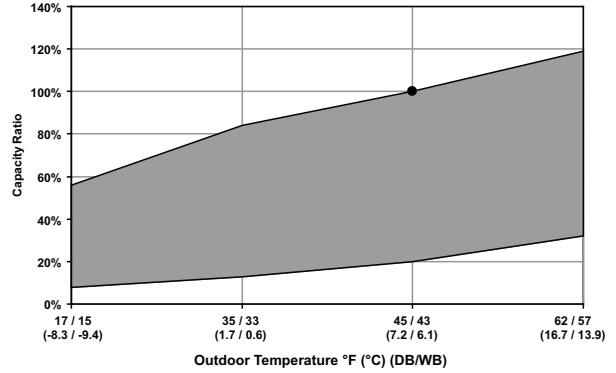

Indoor temperature 75°F (23.4°C) (db) – Indoor Fan High Speed
● = Rating Point

A09179

Fig. 9 – 38GXQ012 / 40GXQ012 Heating

APPLICATION DATA CONTINUED

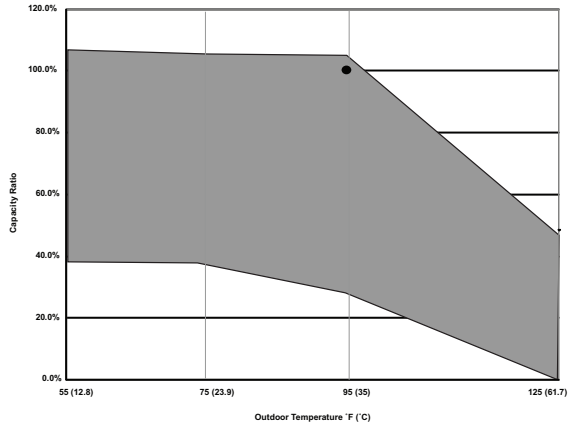

Indoor Temp. 80/67°F (26.7/19.4°C) (db/wb) – Indoor Fan High Speed
● = Rating Point

A10124

Fig. 10 – 38GXC(Q)018 / 40GXC(Q)018 Cooling

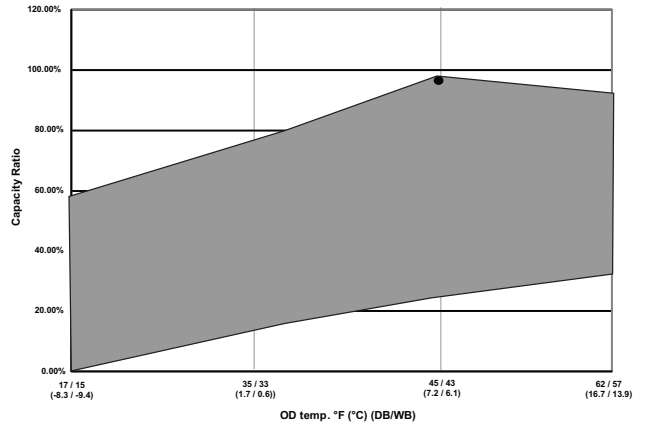

Indoor temperature 75°F (23.4°C) (db) – Indoor Fan High Speed
● = Rating Point

A10125

Fig. 11 – 38GXQ018 / 40GXQ018 Heating

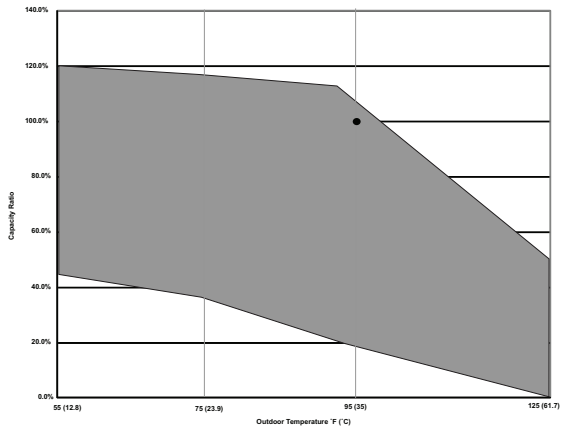

Indoor Temp. 80/67°F (26.7/19.4°C) (db/wb) – Indoor Fan High Speed
● = Rating Point

A10122

Fig. 12 – 38GXC(Q)024 / 40GXC(Q)024 Cooling

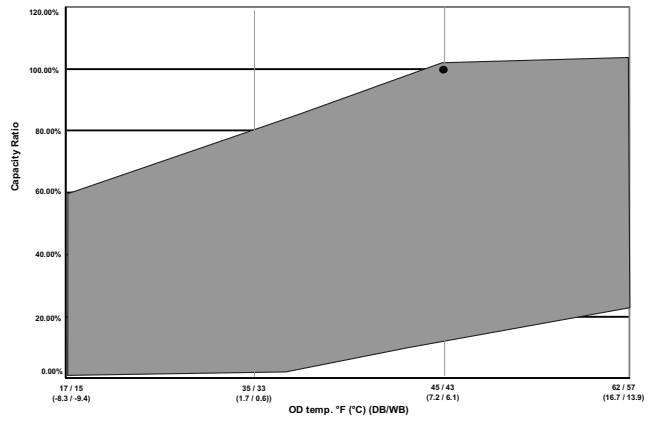

Indoor temperature 75°F (23.4°C) (db) – Indoor Fan High Speed
● = Rating Point

A10123

Fig. 13 – 38GXQ024 / 40GXQ024 Heating

38/40GXC(Q)

UNIT MOUNTING (INDOOR)

Mounting template – The fan coil units are furnished with mounting bracket to hang the unit and mark the location of the wiring, and refrigeration line hole locations.

Support – Adequate support must be provided to handle the weight of all fan coils. Refer to the Physical Data section for weights, and the base unit dimensional drawings for the location of mounting bracket.

Unit Leveling – For reliable operation, units should be level in all planes.

Clearances – Minimum clearance as shown in Fig. 4.

Unit location – Select a location which will provide the best air circulation for the room. These units should be positioned as high as possible on the wall for the best air circulation. The unit return and discharge should not be obstructed by furniture, curtains, or anything which may cause the unit to short cycle or air to recycle. Place the unit in the middle of the selected wall (if possible). Use an outside wall, if available, to make piping easier, and place the unit so it faces the normal location of room occupants.

UNIT MOUNTING (OUTDOOR)

Support – A location which can bear the weight of outdoor unit. Refer to the Physical Data section for weights, and base dimensional drawings.

Unit Leveling – For reliable operation, units should be level in all planes.

Clearances – Minimum clearances, as shown in Fig. 5, must be provided for airflow. The outdoor units are designed for free-blow applications. Air inlets and outlets should not be restricted.

Unit location – A location which is convenient to installation and not exposed to strong wind. If unit is exposed to strong winds, it is recommended that a wind baffle be used. Contact your Carrier representative for drawings. Do not install the outdoor or indoor units in a location with special environmental conditions.

SYSTEM OPERATING CONDITIONS

Cooling operating range:

	Maximum		Minimum	
	DB °F (°C)	WB °F (°C)	DB °F (°C)	WB °F (°C)
Outdoor Unit	115 (46.1)	–	55 (12.78)	–
Indoor Unit	95 (35)	–	55 (12.78)	–

Heating operating range:

	Maximum		Minimum	
	DB °F (°C)	WB °F (°C)	DB °F (°C)	WB °F (°C)
Outdoor Unit	75 (23.9)	–	14 (–10)	–
Indoor Unit	80 (26.7)	–	55 (12.78)	–

METERING DEVICES

These units have capillary tube metering devices in the outdoor unit.

REFRIGERANT LINES

Routing – Refrigerant lines can be routed in any of the four directions shown in Fig. 14.

As viewed from front

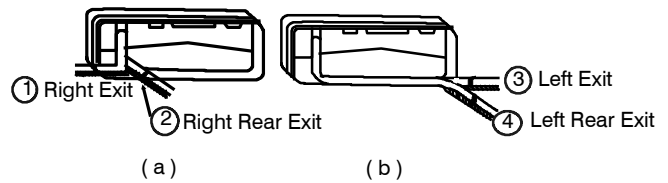

Fig. 14 – Refrigerant Line Routing

A08281

General Guidelines:

1. The 38GXC(Q) units are shipped with full charge of R-410A refrigerant. All charges, line sizing, and capacities are based on runs of 25ft (7.6 m). For runs over 25ft (7.6 m), consult long line section for charge adjustments.
2. Refrigerant lines should not be buried in the ground. If it is necessary to bury the lines, not more than 36 inches (914 mm) should be buried. Provide a minimum of 6 inch (152 mm) vertical rise to service valves to prevent refrigerant migration.
3. Both lines must be insulated. Use a minimum of 1/2 inch (12.7 mm) thick insulation. Closed-cell insulation is recommended in all long-line applications.
4. Special consideration should be given to isolating interconnecting tubing from the building structure. Isolate the tubing so that vibration or noise is not transmitted into the structure.

Long Line Applications:

1. A field fabricated wind baffle is recommended.
2. No change in line sizing is required.
3. Add refrigerant per table below.

ADDITIONAL CHARGE TABLE

Unit Size	Additional Charge, oz./ft – ft. (m)		Max Allowable Length ft. (m)
	10 – 25 (3.05 – 7.62)	> 25 (7.62)	
9 K	0.0	0.24	65 (19.8)
12 K	0.0	0.1	
18 K	0.0	0.1	80 (24.4)
24 K	0.0	0.54	100 (30.5)

4. Reduction in capacity due to long lines can be calculated from the chart below.

CAPACITY LOSS

Unit Size	Capacity Degredation	Line Length ft.(m)				
		25 (7.62)	45 (13.7)	65 (19.8)	80 (24.4)	100 (30.5)
9 K	Cooling %	0.0	2.0	5.0	–	–
	Heating %	0.0	7.0	11.0	–	–
12 K	Cooling %	0.0	2.0	5.0	–	–
	Heating %	0.0	7.0	11.0	–	–
18 K	Cooling %	0.0	1.1	2.2	3.2	–
	Heating %	0.0	3.5	7.0	10.0	–
24 K	Cooling %	0.0	1.8	3.6	–	6.8
	Heating %	0.0	2.3	4.6	–	8.6

DRAIN CONNECTIONS

Install drains to meet the local sanitation codes. If adequate gravity drainage cannot be provided, a field installed condensate pump accessory should be used. The pump has a lift capability of 12 ft (3.6 m) on the discharge side if the pump is mounted in the fan coil or 6 ft (1.8 m) on the suction side if the pump is remote mounted. See the Physical Data tables for drain sizes.

NOTE: The high wall fan coils have internal condensate trap. An external trap is not required.

Drain connections may be routed through alternate locations as shown in Fig. 15.

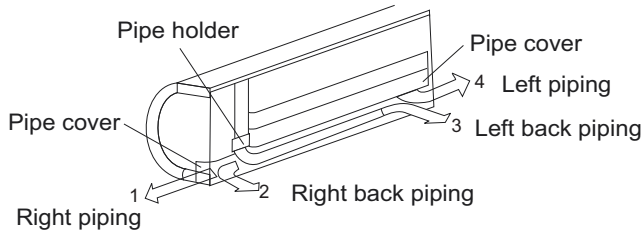

Fig. 15 – Piping Locations

A09112

WIRING

The main power is supplied to the outdoor unit. The field supplied connecting cable from the outdoor unit to the indoor consists of 4 wires and provides the power for the indoor unit as well the communication signal and ground between the outdoor unit and indoor unit.

CONTROL SYSTEM

The 40GXC(Q)/38GXC(Q) unit is equipped with a microprocessor controls to operate the system and give optimum levels of comfort and operating efficiency.

There are microprocessor boards and thermistors located in both the indoor and outdoor units. The thermistors monitor the system operation and control the operating mode. The change in the settings or the modes of operation, use the factory supplied wireless remote control.

The 40GXC(Q)/38GXC(Q) unit has the following operating modes:

- Fan Only
- Auto
- Heating (on Heat Pumps only)
- Cooling
- Dehumidification (Dry)

FAN ONLY - In Fan Only mode, the system filters and circulates the room air without changing the room air temperature.

AUTO - In Auto mode, the system will automatically select one of the following operating modes: cooling, heating or fan only based on the difference between the room temperature and the set point temperature.

HEATING - In the Heating mode, the system heats and filters room air.

COOLING - When in Cooling mode, the fan runs all the time and the system cools, dries and filters room air.

DEHUMIDIFICATION (DRY) - in Dehumidification (Dry) mode, the system dries, filters and slightly cools room temperature. This mode does not take place of a dehumidifier.

In addition to the above modes that are selected by using the remote control, the unit can run in emergency mode by using a manual button. This mode is used when the remote is misplaced or the batteries in the remote died. In this mode the unit will run in AUTO mode with a predetermined set point (76°F/24.4°C)

For more details on the sequence of operation please refer to the service manual for those units.

WIRELESS REMOTE CONTROL

1. A wireless remote control is supplied for system operation.
2. Each battery-operated wireless remote control may be used to control more than one unit.
3. The wireless remote control has a range of 25 ft. (7.6 m).

START-UP SEQUENCE

In both cooling and heating mode, the compressor does a soft start from 0 Hz run speed approximately 52 Hz run speed. The event takes about 55 seconds. This eliminates high inrush currents associated with fixed speed compressors and also reduces the stress on internal compressor parts typically seen with a full speed startup.

COOLING MODE

In Cooling mode, the first step in compressor speed after the soft start is a run speed of approximately 52 Hz for 150 seconds. The next step is a ramp up to approximately 78 Hz.

If, within 20 minutes, the load is satisfied at 78 Hz, the compressor will start to ramp back down in speed in an effort to track the load. If the load is not satisfied within 20 minutes, the compressor speed will ramp up to approximately 85 Hz. The compressor will operate at this speed until the load is satisfied or a maximum of 20 minutes after which the compressor will shut off for 3 minutes.

After 3 minutes the cycle repeats itself until the load is satisfied.

HEATING MODE

In Heating mode, the first step in compressor speed after the soft start is a run speed of approximately 52 Hz for 150 seconds. The next step is a ramp up to approximately 72 Hz.

If, within 25 minutes, the load is satisfied at 72 Hz, the compressor will start to ramp back down in speed in an effort to track the load. If the load is not satisfied within 25 minutes, the compressor speed will ramp up to approximately 82 Hz.

The compressor will operate at this speed until the load is satisfied or a maximum of 18 minutes after which the compressor will shut off for 3 minutes.

After 3 minutes the cycle repeats itself until the load is satisfied.

AIR THROW DATA

Unit Size	Approximate Air Throw ft. (m)			
	Low	Medium	High	Turbo
9 K	18 (5.5)	20 (6.1)	23 (7.0)	NA
12 K	19 (5.8)	21 (6.4)	25 (7.6)	NA
18 K	25 (7.6)	30 (9.1)	32 (9.8)	35 (10.7)
24 K	23 (7.0)	27 (8.2)	30 (9.1)	37 (11.3)

SOUND RATINGS

Outdoor Units

Model Number	Sound Power dBA	Sound Pressure dBA
38GXC009---1	64	53
38GXC012---1	66	55
38GXC018---3	67	56
38GXC024---3	68	57
38GXQ009---1 (cool/heat)	65/66	54/55
38GXQ012---1 (cool/heat)	65/66	54/55
38GXQ018---3 (cool/heat)	67/67	56/56
38GXQ024---3 (cool/heat)	68/69	57/58

Indoor Units

Model Number	Low		Medium		High		Turbo	
	Sound Power dBA	Sound Pressure dBA	Sound Power dBA	Sound Pressure dBA	Sound Power dBA	Sound Pressure dBA	Sound Power dBA	Sound Pressure dBA
40GXC009---1	44	43	53	42	54	43	-	-
40GXC012---1	48	37	51	40	55	44	-	-
40GXC018---3	52	41	55	44	57	46	60	49
40GXC024---3	48	37	51	40	54	43	62	51
40GXQ009---1 (cool/heat)	40/42	29/30	52/52	41/41	55/54	44/43	-	-
40GXQ012---1 (cool/heat)	48/50	37/39	51/51	40/40	55/54	44/43	-	-
40GXQ018---3 (cool/heat)	52/48	41/37	55/52	44/41	57/55	46/44	60/59	49/48
40GXQ024---3 (cool/heat)	48/50	37/39	51/51	40/40	54/54	43/43	62/61	51/50

NOTES:

1. Sound power ratings are per ARI 270 and ARI 350
2. Sound pressure ratings are estimated sound pressure, 3 feet (.91 m) from the unit, based on sound power data.

ELECTRICAL DATA

UNIT SIZE	SYSTEM VOLTAGE	OPERATING VOLTAGE*	COMPRESSOR		OUTDOOR FAN			INDOOR FAN†				MCA	MAX FUSE/CB AMP
	VOLT-PH-HZ	MAX/MIN	RLA	LRA	FLA	HP	W	VOLTS	FLA	HP	W		
9 K	115 -1 - 60	127/104	4.0	33	0.6	0.04	30	115	0.3	0.027	30	20	25
12 K	115 -1 - 60	127/104							0.45		20		
18 K	208/230 - 1 - 60	253/187	7.46	41	0.65	0.082	60	208/230	0.24	0.027	20	14	25
24 K	208/230 - 1 - 60	253/187	8.4	41	0.65	0.082	60	208/230	0.38	0.041	35	16	30

* Permissible limits of the voltage range at which the unit will operate satisfactorily

† Indoor fan powered from outdoor unit.

LEGEND

FLA - Full Load Amps

LRA - Locked Rotor Amps

MCA - Minimum Circuit Amps

RLA - Rated Load Amps

38/40GXC(Q)

PART 1 – GENERAL

1.01 System Description

- A. Outdoor air-cooled split system compressor sections suitable for on-the-ground, rooftop, wall hung or balcony mounting. Units shall consist of a variable speed rotary compressor, an air-cooled coil, propeller-type draw-through outdoor fan, reversing valve, accumulator, metering devices, and control box. Units shall discharge horizontally as shown on the contract drawings. Units shall function as the outdoor component of an air-to-air heat pump system.
- B. Units shall be used in a refrigeration circuit matched to duct-free heat pump fan coil units.

1.02 Agency Listings

- C. Unit construction shall comply with ANSI/ASHRAE 15, latest revision, and with NEC.
- D. Units shall be evaluated in accordance with UL standard 1995.
- E. Units shall be listed in CEC directory.
- F. Unit cabinet shall be capable of withstanding 500-hour salt spray test per Federal Test Standard no. 141 (method 6061).
- G. Air-cooled condenser coils shall be leak tested at 573 psig.

1.03 Delivery, Storage, And Handling

Units shall be shipped in one piece and shall be stored and handled per manufacturer's recommendations.

1.04 Warranty (For Inclusion By Specifying Engineer)

PART 2 – PRODUCTS

2.01 Equipment

A. General:

Factory assembled, single piece, air-cooled outdoor unit. Contained within the enclosure shall be all factory wiring, piping, controls, and compressor.

B. Unit Cabinet:

- 1. Unit cabinet shall be constructed of galvanized steel, bonderized and coated with baked-enamel finish on inside and outside.
- 2. Unit access panel should be removable with minimal screws and shall provide full access to the compressor, fan, and control components.
- 3. Outdoor compartment shall be isolated and have an acoustic lining to assure quiet operation.

C. Fans:

- 1. Outdoor fans shall be direct-drive propeller type, and shall discharge air horizontally. Fan shall draw air through the outdoor coil.
- 2. Outdoor fan motors shall be totally-enclosed, single phase motors with class B insulation and permanently-lubricated ball bearings. Motor shall be protected by internal thermal overload protection.
- 3. Shaft shall have inherent corrosion resistance.
- 4. Outdoor fan openings shall be equipped with PVC metal/mesh coated protection grille over fan.

D. Compressor

- 1. Compressor shall be fully hermetic variable speed rotary type.
- 2. Compressor shall be Three phase, inverter driven.
- 3. Compressor shall be equipped with oil system, operating oil charge, and motor.
- 4. Motor shall be NEMA rated class F, suitable for operation in refrigerant atmosphere.
- 5. Compressor assembly shall be installed on rubber vibration isolators.
- 6. The inverter and compressor shall be protected against over temperature and over current.

E. Outdoor Coil:

Coil shall be constructed of Aluminum fins mechanically bonded to seamless copper tubes, which are cleaned, dehydrated and sealed.

F. Refrigerant Components:

Refrigerant circuit components shall include brass external liquid line service valve with service gauge port connections, suction line service valve with service gage connection port, service gage port connections on compressor suction and discharge lines with Schrader type fittings with brass caps, accumulator, reversing valve (on heat pump units).

G. Safeties:

Operating safeties shall be factory selected, assembled, and tested. The minimum functions shall include the following:

- 1. Compressor discharge over temperature protection.
- 2. System low voltage protection.
- 3. Compressor overload protection.
- 4. Compressor over current protection.
- 5. IPM module protection.

H. Electrical Requirements:

- 1. Units shall operate on single-phase, 60 Hz power at 115 v. for unit sizes 009-012.
- 2. Unit electrical power shall be a single point connection.
- 3. All power and control wiring must be installed per NEC and all local electrical codes.
- 4. Units shall have high and low-voltage terminal block connections.

I. Special Features (Field Installed):

- 1. Wind baffle (field fabricated)

INDOOR WALL-MOUNTED DUCT-FREE UNITS

Size Range: 3/4 and 1 Ton Nominal Cooling and Heating Capacity

Carrier Model Number: **40GXC(Q)**

PART 1 – GENERAL

1.01 System Description

Indoor, wall-mounted, direct expansion fan coils are matched with heat pump outdoor units.

1.02 Agency Listings

Unit shall be rated per ARI Standards 210/240 and listed in the ARI directory as a matched system.

1.03 Delivery, Storage, And Handling

Units shall be shipped in one piece and shall be stored and handled per manufacturer's recommendations.

1.04 Warranty (For Inclusion By Specifying Engineer)

PART 2 – PRODUCTS

2.01 Equipment

A. General:

Indoor, direct-expansion, wall-mounted fan coil. Unit shall be complete with cooling/heating coil, fan, fan motor, piping connectors, electrical controls, microprocessor control system, and integral temperature sensing. Unit shall be furnished with integral wall mounting bracket and mounting hardware.

B. Unit Cabinet:

Cabinet discharge and inlet grilles shall be attractively styled, high-impact polystyrene. Cabinet shall be fully insulated for improved thermal acoustic performance.

C. Fans:

1. Fan shall be tangential direct-drive blower type with air intake at the top of the unit and discharge at the bottom front. Automatic, motor-driven vertical air sweep shall be provided standard.
2. Air sweep operation shall be useable selectable. The vertical sweep may be adjusted (using the remote control) and the horizontal air direction maybe be set manually.

D. Coil:

Coil shall be copper tube with aluminum fins and galvanized steel tube sheets. Fins shall be bonded to the tubes by mechanical expansion. A drip pan under the coil shall have a drain connection for hose attachment to remove condensate. Condensate pan shall have internal trap.

E. Motors:

Motors shall be open drip-proof, permanently lubricated ball bearing with inherent overload protection. Fan motors shall be 3-speed.

F. Controls:

Controls shall consist of a microprocessor-based control system which shall control space temperature, determine optimum fan speed, and run self diagnostics. The temperature control range shall be from 62°F to 84°F (16.7°C to 28.9°C).

The unit shall have the following functions as a minimum:

1. Automatic restart after power failure at the same operating conditions as at failure.

2. A timer function to provide a minimum 24-hour timer cycle for system Auto Start/Stop.
3. Temperature sensing control to enter set points and operating conditions.
4. Wireless infrared remote control to enter set points and operating conditions.
5. Automatic air sweep control to provide on or off activation of air sweep louvers.
6. Dehumidification mode shall provide increased latent removal capability by modulating system operation and set point temperature.
7. Fan-only operation to provide room air circulation when no cooling is required.
8. Diagnostics shall provide continuous checks of unit operation and warn of possible malfunctions. Error messages shall be displayed at the unit.
9. Fan speed control shall be user-selectable: high, medium, low or microprocessor controlled automatic operation during all operating modes.

The unit shall be protected against the following:

1. Indoor coil freeze up
2. Indoor coil high temperature protection shall be provided to detect excessive indoor discharge temperature when unit is in heat pump mode.

G. Filters:

Units shall have filter track with factory-supplied cleanable filters.

H. Electrical Requirements:

Indoor fan motor to operate 115 volts on sizes 009-012. Power is supplied from the indoor unit.

I. Operating Characteristics:

The 40GXC(Q) system shall have a minimum listed SEER (seasonal energy efficiency ratio) of 16 SEER at ARI conditions, and a minimum HSPF of 7.7.

J. Refrigerant Lines:

All units should have refrigerant line connections that can be oriented to connect from the left, right, or back of unit. Both refrigerant lines need to be insulated (on heat pump units).

K. Special Features (Field Installed):

1. Condensate Pump: The condensate pump shall remove condensate from the drain pan when gravity drainage cannot be used. Pump shall be designed for quiet operation. Pump shall consist of two parts: an internal reservoir/sensor assembly, and a remote sound-shielded pump assembly. A liquid level sensor in the reservoir shall stop cooling operation if the liquid level in the reservoir is unacceptable.