

## Product Data

### Split System Cooling

4A7A6024N1000A	4A7A6018J1000A
4A7A6036N1000A	4A7A6024J1000A
4A7A6048N1000A	4A7A6030J1000A/B
4A7A6060N1000A	4A7A6035J1000A
	4A7A6036J1000B
	4A7A6041J1000A
	4A7A6042J1000A
	4A7A6048J1000A
	4A7A6049J1000A
	4A7A6060J1000B
	4A7A6060K1000A
	4A7A6061C1000A

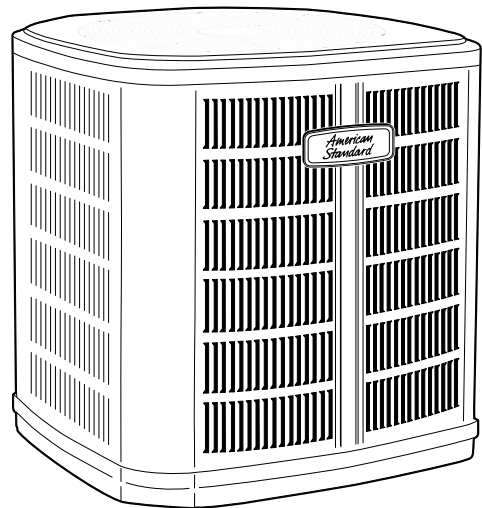

**Note:** "Graphics in this document are for representation only. Actual model may differ in appearance."

## Product Specifications

Model No. <sup>(a)</sup>	4A7A6024N1000A	4A7A6036N1000A	4A7A6048N1000A	4A7A6060N1000A
POWER CONNS. – V/PH/HZ <sup>(b)</sup>	208/230/1/60	208/230/1/60	208/230/1/60	208/230/1/60
MIN. BRCH. CIR. AMPACITY	13.4	18.4	28	35
BR. CIR. PROT. RTG. – MAX. (AMPS)	20	30	45	60
COMPRESSOR	DURATION™ - SCROLL	DURATION™ - SCROLL	DURATION™ - SCROLL	DURATION™ - SCROLL
No. Compress. – No. Stages	1 – 2	1 – 2	1 – 2	1 – 2
RL AMPS – LR AMPS	10.2 – 55.2	14.2 – 78.1	20.4 – 122.1	26.9 – 152.9
Outdoor Fan FL AMPS	0.71	0.71	2.80	1.30
Fan HP	1/8	1/8	1/3	1/4
Fan Dia (inches)	27.6	27.6	27.6	27.6
Coil	SPINE FIN™	SPINE FIN™	SPINE FIN™	SPINE FIN™
Refrigerant R-410A	9 LBS., 4 OZ	8 LBS., 12 OZ	13 LBS., 3 OZ	12 LBS., 9 OZ
LINE SIZE – IN. O.D. GAS <sup>(c)</sup>	3/4	3/4	7/8	1–1/8
LINE SIZE – IN. O.D. LIQ. <sup>(c)</sup>	3/8	3/8	3/8	3/8
Dimensions H x W X D Crated (IN.)	46.4 x 35.1 x 38.7	51 x 35.1 x 38.7	51 x 35.1 x 38.7	51 x 35.1 x 38.7
Weight – Shipping (lbs.)	280	288	296	312
Weight – Net (lbs.)	244	250	259	275
Start Components	NO	NO	NO	NO
Sound Enclosure	NO	NO	NO	NO
Compressor Sump Heat	NO	NO	NO	NO
<b>Optional Accessories:</b>				
Rubber Isolator Kit	BAYISLT101	BAYISLT101	BAYISLT101	BAYISLT101
Snow Leg - Base & Cap 4" High	BAYLEGS002	BAYLEGS002	BAYLEGS002	BAYLEGS002
Snow Leg - 4" Extension	BAYLEGS003	BAYLEGS003	BAYLEGS003	BAYLEGS003
Hard Start Kit Scroll	BAYKSKT263	BAYKSKT263	BAYKSKT266	BAYKSKT266
Crankcase Heater Kit	BAYCCHT301	BAYCCHT301	BAYCCHT301	BAYCCHT301
Extreme Condition Mounting Kit	BAYECMT004	BAYECMT004	BAYECMT004	BAYECMT004
Vertical Discharge Air Kit Base 4	BAYVDTA003	BAYVDTA004	BAYVDTA004	BAYVDTA004
Auto Charge Solenoid Kit	BAYCAKT001	BAYCAKT001	BAYCAKT001	BAYCAKT001
Refrigerant Lineset <sup>(d)</sup>				

<sup>(a)</sup> Certified in accordance with the Air-Source Unitary Heat Pump Equipment certification program which is based on AHRI Standard 210/240.

<sup>(b)</sup> Calculated in accordance with N.E.C. Only use HACR circuit breakers or fuses.

<sup>(c)</sup> Standard line lengths – 60', Standard lift – 25' Suction and Liquid line. For Greater lengths and lifts refer to refrigerant piping software Pub#32–3312–0\* (\* denotes latest revision).

<sup>(d)</sup> 25, 30, 35, and 50 foot linesets available. For a complete listing of lineset options available from equipment or supply stores, refer to the American Standard Quick Reference Guide.

**Product Specifications**

<b>Model No.</b> <sup>(a)</sup>	4A7A6018J1000A	4A7A6024J1000A	4A7A6030J1000A	4A7A6030J1000B
POWER CONNS. – V/PH/HZ <sup>(b)</sup>	208/230/1/60	208/230/1/60	208/230/1/60	208/230/1/60
MIN. BRCH. CIR. AMPACITY	12	13	17	14
BR. CIR. PROT. RTG. – MAX. (AMPS)	20	25	25	25
COMPRESSOR	DURATION™ - SCROLL	DURATION™ - SCROLL	DURATION™ - SCROLL	DURATION™ - SCROLL
RL AMPS – LR AMPS	9 – 47.5	10.1 – 52	12.8 – 67.8	10.9 – 62.6
Outdoor Fan FL AMPS	0.64	0.64	0.64	0.64
Fan HP	1/8	1/8	1/8	1/8
Fan Dia (inches)	23.02 – 1	23.02	23.02	23.02
Coil	SPINE FIN™	SPINE FIN™	SPINE FIN™	SPINE FIN™
Refrigerant R-410A	4 LBS., 15 OZ	4 LBS., 11 OZ	5 LBS., 8 OZ	5 LBS., 8 OZ
VALVE CONNECTION SIZE – IN. O.D. GAS	3/4	3/4	3/4	3/4
VALVE CONNECTION SIZE – IN. O.D. LIQ.	3/8	3/8	3/8	3/8
LINE SIZE – IN. O.D. GAS <sup>(c)</sup>	3/4	3/4	3/4	3/4
LINE SIZE – IN. O.D. LIQ.	3/8	3/8	3/8	3/8
Charge Spec. Subcooling	8°F	8°F	8°F	8°F
Dimensions H x W X D Crated (IN.)	34 x 30.1 x 33	34 x 30.1 x 33	42 x 30.1 x 33	42 x 30.1 x 33
Weight – Shipping (lbs.)	189	190	220	220
Weight – Net (lbs.)	161	162	184	184
<b>Optional Accessories:</b>				
Anti-short Cycle Timer	TAYASCT501A	TAYASCT501A	TAYASCT501A	TAYASCT501A
Evaporator Defrost Control	AY28X079	AY28X079	AY28X079	AY28X079
Rubber Isolator Kit	BAYISLT101	BAYISLT101	BAYISLT101	BAYISLT101
Extreme Condition Mount Kit	BAYECMT023	BAYECMT023	BAYECMT023	BAYECMT023
Start Kit	BAYKSKT263	BAYKSKT263	BAYKSKT263	BAYKSKT263
Crankcase Heater Kit	BAYCCHT302	BAYCCHT302	BAYCCHT302	BAYCCHT302
Seacoast Kit	BAYSEAC001	BAYSEAC001	BAYSEAC001	BAYSEAC001
Low Ambient Kit	BAYLOAM103	BAYLOAM103	BAYLOAM103	BAYLOAM103
Service Valve Panel Cover	AAYSVPANL0032AA	AAYSVPANL0032AA	AAYSVPANL0044AA	AAYSVPANL0044AA
Refrigerant Lineset <sup>(d)</sup>				

<sup>(a)</sup> Certified in accordance with the Unitary Air-conditioner equipment certification program which is based on AHRI standard 210/240.

<sup>(b)</sup> Calculated in accordance with N.E.C. Only use HACR circuit breakers or fuses.

<sup>(c)</sup> Standard line lengths – 60', Standard lift – 60' Suction and Liquid line. For Greater lengths and lifts refer to refrigerant piping software Pub#32–3312–0\* (\* denotes latest revision).

<sup>(d)</sup> 25, 30, 35, and 50 foot linesets available. For a complete listing of lineset options available from equipment or supply stores, refer to the American Standard Quick Reference Guide.

**Product Specifications**

<b>Model No.</b> <sup>(a)</sup>	4A7A6035J1000A	4A7A6036J1000B	4A7A6041J1000A
POWER CONNS. – V/PH/HZ <sup>(b)</sup>	208/230/1/60	208/230/1/60	208/230/1/60
MIN. BRCH. CIR. AMPACITY	16	18	20
BR. CIR. PROT. RTG. – MAX. (AMPS)	25	30	35
COMPRESSOR	DURATION™ - SCROLL	DURATION™ - SCROLL	DURATION™ - SCROLL
RL AMPS – LR AMPS	12.2 – 80.1	13.6 – 79	15.4 – 92.1
Outdoor Fan FL AMPS	0.77	0.77	1.05
Fan HP	1/8	1/8	1/5
Fan Dia (inches)	23.02	24	27.5
Coil	SPINE FIN™	SPINE FIN™	SPINE FIN™
Refrigerant R-410A	5 LBS., 11 OZ	6 LBS., 8 OZ	6 LBS., 6 OZ
VALVE CONNECTION SIZE – IN. O.D. GAS	3/4	3/4	3/4
VALVE CONNECTION SIZE – IN. O.D. LIQ.	3/8	3/8	3/8
LINE SIZE – IN. O.D. GAS <sup>(c)</sup>	3/4	7/8	7/8
LINE SIZE – IN. O.D. LIQ.	3/8	3/8	3/8
Charge Spec. Subcooling	10°F	8°F	10°F
Dimensions H x W X D Crated (IN.)	38 x 30.1 x 33	42 x 35.1 x 38.7	42 x 35.1 x 38.7
Weight – Shipping (lbs.)	183	246	246
Weight – Net (lbs.)	156	212	212
<b>Optional Accessories:</b>			
Anti-short Cycle Timer	TAYASCT501A	TAYASCT501A	TAYASCT501A
Evaporator Defrost Control	AY28X079	AY28X079	AY28X079
Rubber Isolator Kit	BAYISLT101	BAYISLT101	BAYISLT101
Extreme Condition Mount Kit	BAYECMT004	BAYECMT004	BAYECMT004
Start Kit	BAYKSKT263	BAYKSKT263	BAYKSKT263
Crankcase Heater Kit	BAYCCHT302	BAYCCHT302	BAYCCHT302
Seacoast Kit	BAYSEAC001	BAYSEAC001	BAYSEAC001
Low Ambient Kit	BAYLOAM103	BAYLOAM103	BAYLOAM103
Service Valve Panel Cover	AAYSVPANL0044AA	AAYSVPANL0044AA	AAYSVPANL0046AA
Refrigerant Lineset <sup>(d)</sup>			

<sup>(a)</sup> Certified in accordance with the Unitary Air-conditioner equipment certification program which is based on AHRI standard 210/240.

<sup>(b)</sup> Calculated in accordance with N.E.C. Only use HACR circuit breakers or fuses.

<sup>(c)</sup> Standard line lengths – 60', Standard lift – 60' Suction and Liquid line. For Greater lengths and lifts refer to refrigerant piping software Pub#32-3312-0\* (\* denotes latest revision).

<sup>(d)</sup> 25, 30, 35, and 50 foot linesets available. For a complete listing of lineset options available from equipment or supply stores, refer to the American Standard Quick Reference Guide.

**Product Specifications**

<b>Model No.</b> <sup>(a)</sup>	4A7A6042J1000A	4A7A6048J1000A	4A7A6049J1000A
POWER CONNS. – V/PH/HZ <sup>(b)</sup>	208/230/1/60	208/230/1/60	208/230/1/60
MIN. BRCH. CIR. AMPACITY	21	24	26
BR. CIR. PROT. RTG. – MAX. (AMPS)	35	40	40
COMPRESSOR	DURATION™ - SCROLL	DURATION™ - SCROLL	DURATION™ - SCROLL
RL AMPS – LR AMPS	16.7 – 109	18.5 – 124	18.5 – 124
Outdoor Fan FL AMPS	0.64	0.93	2.80
Fan HP	1/8	1/5	1/3
Fan Dia (inches)	27.5	27.5	27.5
Coil	SPINE FIN™	SPINE FIN™	SPINE FIN™
Refrigerant R-410A	8 LBS., 2 OZ	7 LBS., 2 OZ	10 LBS., 10 OZ
VALVE CONNECTION SIZE – IN. O.D. GAS	7/8	7/8	7/8
VALVE CONNECTION SIZE – IN. O.D. LIQ.	3/8	3/8	3/8
LINE SIZE – IN. O.D. GAS <sup>(c)</sup>	7/8	7/8	7/8
LINE SIZE – IN. O.D. LIQ.	3/8	3/8	3/8
Charge Spec. Subcooling	8°F	8°F	10°F
Dimensions H x W X D Crated (IN.)	50.4 x 35.1 x 38.7	50.4 x 35.1 x 38.7	50.4 x 35.1 x 38.7
Weight – Shipping (lbs.)	302	306	322
Weight – Net (lbs.)	252	256	272
<b>Optional Accessories:</b>			
Anti-short Cycle Timer	TAYASCT501A	TAYASCT501A	TAYASCT501A
Evaporator Defrost Control	AY28X079	AY28X079	AY28X079
Rubber Isolator Kit	BAYISLT101	BAYISLT101	BAYISLT101
Extreme Condition Mount Kit	BAYECMT004	BAYECMT004	BAYECMT004
Start Kit	BAYKSKT263	BAYKSKT263	BAYKSKT263
Crankcase Heater Kit	BAYCCHT302	BAYCCHT302	BAYCCHT302
Seacoast Kit	BAYSEAC001	BAYSEAC001	BAYSEAC001
Low Ambient Kit	BAYLOAM103	BAYLOAM103	BAYLOAM103
Service Valve Panel Cover	AAYSVPANL0046AA	AAYSVPANL0046AA	AAYSVPANL0046AA
Refrigerant Lineset <sup>(d)</sup>			

<sup>(a)</sup> Certified in accordance with the Unitary Air-conditioner equipment certification program which is based on AHRI standard 210/240.

<sup>(b)</sup> Calculated in accordance with N.E.C. Only use HACR circuit breakers or fuses.

<sup>(c)</sup> Standard line lengths – 60', Standard lift – 60' Suction and Liquid line. For Greater lengths and lifts refer to refrigerant piping software Pub#32-3312-0\* (\* denotes latest revision).

<sup>(d)</sup> 25, 30, 35, and 50 foot linesets available. For a complete listing of lineset options available from equipment or supply stores, refer to the American Standard Quick Reference Guide.

**Product Specifications**

<b>Model No.</b> <sup>(a)</sup>	4A7A6060J1000B	4A7A6060K1000A	4A7A6061C1000A
POWER CONNS. – V/PH/HZ <sup>(b)</sup>	208/230/1/60	208/230/1/60	208/230/1/60
MIN. BRCH. CIR. AMPACITY	27	28	29
BR. CIR. PROT. RTG. – MAX. (AMPS)	45	50	50
COMPRESSOR	DURATION™ - SCROLL	DURATION™ - SCROLL	DURATION™ - SCROLL
RL AMPS – LR AMPS	20.8 – 127.1	21.9 – 118.7	20.8 – 127.1
Outdoor Fan FL AMPS	1.05	0.97	1.05
Fan HP	1/5	1/5	1/5
Fan Dia (inches)	27.5	27.5	27.6
Coil	SPINE FIN™	SPINE FIN™	SPINE FIN™
Refrigerant R-410A	10 LBS., 6 OZ	9 LBS., 8 OZ	11 LBS., 13 OZ
VALVE CONNECTION SIZE – IN. O.D. GAS	7/8	7/8	7/8
VALVE CONNECTION SIZE – IN. O.D. LIQ.	3/8	3/8	3/8
LINE SIZE – IN. O.D. GAS <sup>(c)</sup>	1–1/8	1–1/8	1–1/8
LINE SIZE – IN. O.D. LIQ.	3/8	3/8	3/8
Charge Spec. Subcooling	10°F	10°F	10°F
Dimensions H x W X D Crated (IN.)	50.4 x 35.1 x 38.7	50.4 x 35.1 x 38.7	50.4 x 35.1 x 38.7
Weight – Shipping (lbs.)	327	302	317
Weight – Net (lbs.)	277	252	280
<b>Optional Accessories:</b>			
Anti-short Cycle Timer	TAYASCT501A	TAYASCT501A	TAYASCT501A
Evaporator Defrost Control	AY28X079	AY28X079	AY28X079
Rubber Isolator Kit	BAYISLT101	BAYISLT101	BAYISLT101
Extreme Condition Mount Kit	BAYECMT004	BAYECMT004	BAYECMT004
Start Kit	BAYKSKT263	BAYKSKT263	BAYKSKT263
Crankcase Heater Kit	BAYCCHT302	BAYCCHT302	BAYCCHT302
Seacoast Kit	BAYSEAC001	BAYSEAC001	BAYSEAC001
Low Ambient Kit	BAYLOAM103	BAYLOAM103	BAYLOAM103
Service Valve Panel Cover	AAYSVPANL0046AA	AAYSVPANL0046AA	AAYSVPANL0046AA
Refrigerant Lineset <sup>(d)</sup>			

<sup>(a)</sup> Certified in accordance with the Unitary Air-conditioner equipment certification program which is based on AHRI standard 210/240.

<sup>(b)</sup> Calculated in accordance with N.E.C. Only use HACR circuit breakers or fuses.

<sup>(c)</sup> Standard line lengths – 60', Standard lift – 60' Suction and Liquid line. For Greater lengths and lifts refer to refrigerant piping software Pub#32–3312–0\* (\* denotes latest revision).

<sup>(d)</sup> 25, 30, 35, and 50 foot linesets available. For a complete listing of lineset options available from equipment or supply stores, refer to the American Standard Quick Reference Guide.

## Sound Power Level

Sound Power Level									
MODEL	A-Weighted Sound Power Level [dB(A)]	Full Octave Sound Power(dB)							
		63 Hz*	125 Hz	250 Hz	500 Hz	1000 Hz	2000 Hz	4000 Hz	8000 Hz
4A7A6024N	72	70	69	63	66	60	56	53	48
4A7A6036N	72	64	67	65	64	60	56	54	50
4A7A6048N	73	70	67	68	66	63	56	53	49
4A7A6060N	74	68	70	66	69	66	57	57	53

Note: Rated in accordance with AHRI Standard 270-2008 \*For Reference Only

Sound Power Level									
MODEL	A-Weighted Sound Power Level [dB(A)]	Full Octave Sound Power(dB)							
		63 Hz*	125 Hz	250 Hz	500 Hz	1000 Hz	2000 Hz	4000 Hz	8000 Hz
4A7A6018J	73	79	69	67	70	70	64	59	53
4A7A6024J	73	79	69	67	70	70	64	59	53
4A7A6030J	73	79	69	67	70	70	64	59	53
4A7A6035J	71	78	72	69	68	66	61	58	53
4A7A6036J	71	78	72	69	68	66	61	58	53
4A7A6041J	72	81	75	71	70	68	63	58	53
4A7A6042J	72	81	75	71	70	68	63	58	53
4A7A6048J	72	81	75	71	70	68	63	58	53
4A7A6049J	72	81	75	71	70	68	63	58	53
4A7A6060J	72	81	75	71	70	68	63	58	53
4A7A6060K	72	81	75	71	70	68	63	58	53
4A7A6061C	74	68	56	63	73	69	64	59	51

Note: Rated in accordance with AHRI Standard 270-2008 \*For Reference Only

## Accessory Description and Usage

**Anti-Short Cycle Timer** — Solid state timing device that prevents compressor recycling until five (5) minutes have elapsed after satisfying call or power interruptions. Use in area with questionable power delivery, commercial applications, long lineset, etc.

**Evaporation Defrost Control** — SPST Temperature actuated switch that cycles the condenser off as indoor coil reaches freeze-up conditions. Used for low ambient cooling to 30°F with TXV.

**Rubber Isolators** — Five (5) large rubber donuts to isolate condensing unit from transmitting energy into mounting frame or pad. Use on any application where sound transmission needs to be minimized.

**Hard Start Kit** — Start capacitor and relay to assist compressor motor startup. Use in areas with marginal power supply, on long linesets, low ambient conditions, etc.

**Extreme Condition Mount Kit** — Bracket kits to securely mount condensing unit to a frame or pad without removing any panels. Use in areas with high winds, or on commercial roof tops, etc.

### AHRI Standard Capacity Rating Conditions

AHRI Standard 210/240 Rating Conditions

1. Cooling 80°F DB, 67°F WB air entering indoor coil, 95°F DB air entering outdoor coil.
2. High Temperature Heating 47°F DB, 43°F WB air entering outdoor coil, 70°F DB air entering indoor coil.
3. Low Temperature Heating 17°F DB air entering indoor coil.
4. Rated indoor airflow for heating is the same as for cooling.

**AHRI Standard 270 Rating Conditions** — (Noise rating numbers are determined with the unit in cooling operations.) Standard Noise Rating number is at 95°F outdoor air.

## Model Nomenclature

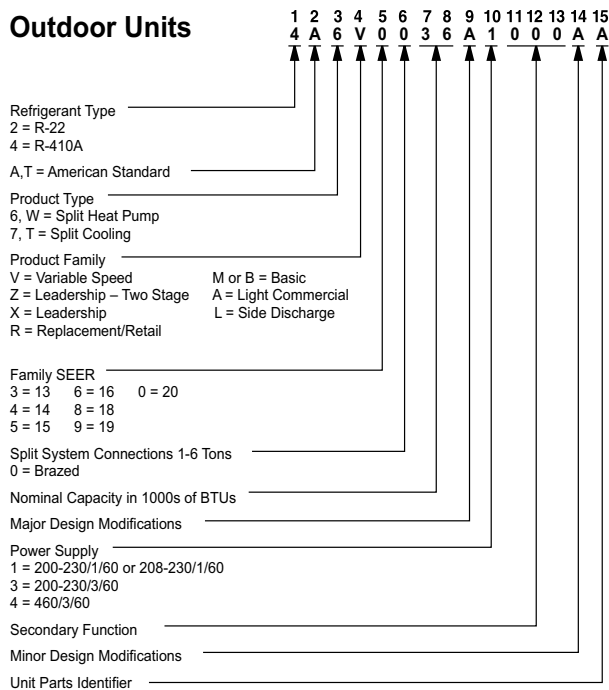

# Schematic Diagrams

Figure 1. 024N & 036N Models

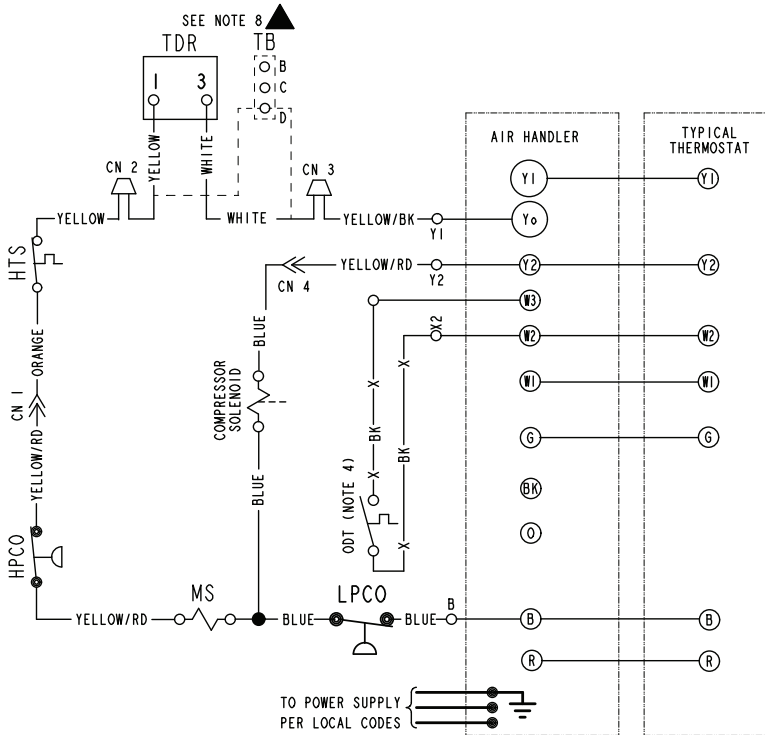
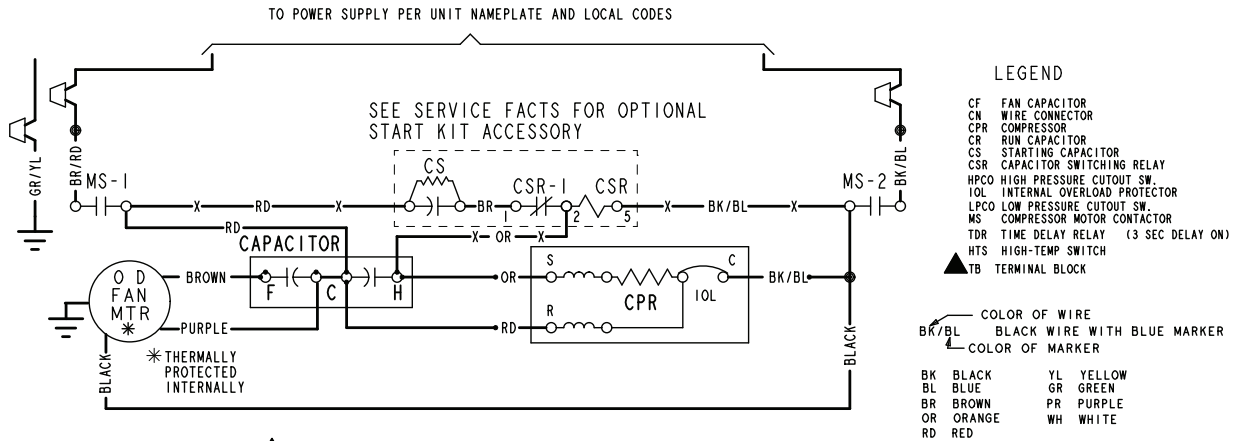

<p>▲ <b>WARNING</b> HAZARDOUS VOLTAGE! DISCONNECT ALL ELECTRIC POWER INCLUDING REMOTE DISCONNECTS BEFORE SERVICING. FAILURE TO DISCONNECT POWER BEFORE SERVICING CAN CAUSE SEVERE PERSONAL INJURY OR DEATH!</p>	<p>▲ <b>CAUTION</b> USE COPPER CONDUCTORS ONLY! UNIT TERMINALS ARE NOT DESIGNED TO ACCEPT OTHER TYPES OF CONDUCTORS. FAILURE TO DO SO MAY CAUSE DAMAGE TO THE EQUIPMENT!</p>
-----------------------------------------------------------------------------------------------------------------------------------------------------------------------------------------------------------------------------	------------------------------------------------------------------------------------------------------------------------------------------------------------------------------------------

**NOTES:**

1. BE SURE POWER SUPPLY AGREES WITH EQUIPMENT NAMEPLATE.
2. POWER WIRING AND GROUNDING OF EQUIPMENT MUST COMPLY WITH LOCAL CODES.
3. LOW VOLTAGE WIRING TO BE NO. 18 AWG MINIMUM CONDUCTOR.
4. IF OUTDOOR THERMOSTAT (ODT) IS NOT USED, CONNECT W2 TO W3.
5. WITH Y1 ENERGIZED, INDOOR FAN IS 1ST STAGE AIRFLOW.
6. WITH Y1 & Y2 ENERGIZED, INDOOR FAN IS 2ND STAGE AIRFLOW.
7. SEE AIR HANDLER INSTALLER GUIDE FOR DIP SWITCH CONFIGURATIONS.
- ▲ 8. USE EITHER TDR OR TB. DO NOT USE BOTH IN ONE MODEL. TB IS ALTERNATE FOR TDR.

FOR CANADIAN INSTALLATIONS  
POUR INSTALLATIONS CANADIENNES

**CAUTION: NOT SUITABLE FOR USE ON SYSTEMS EXCEEDING 150V TO-GROUND.**  
**ATTENTION: NE CONVIENT PAS AUX INSTALLATIONS DE PLUS DE 150 V A LA TERRE.**

PRINTED FROM D157615P04 REV B

**Figure 2. 024N & 036N Models**

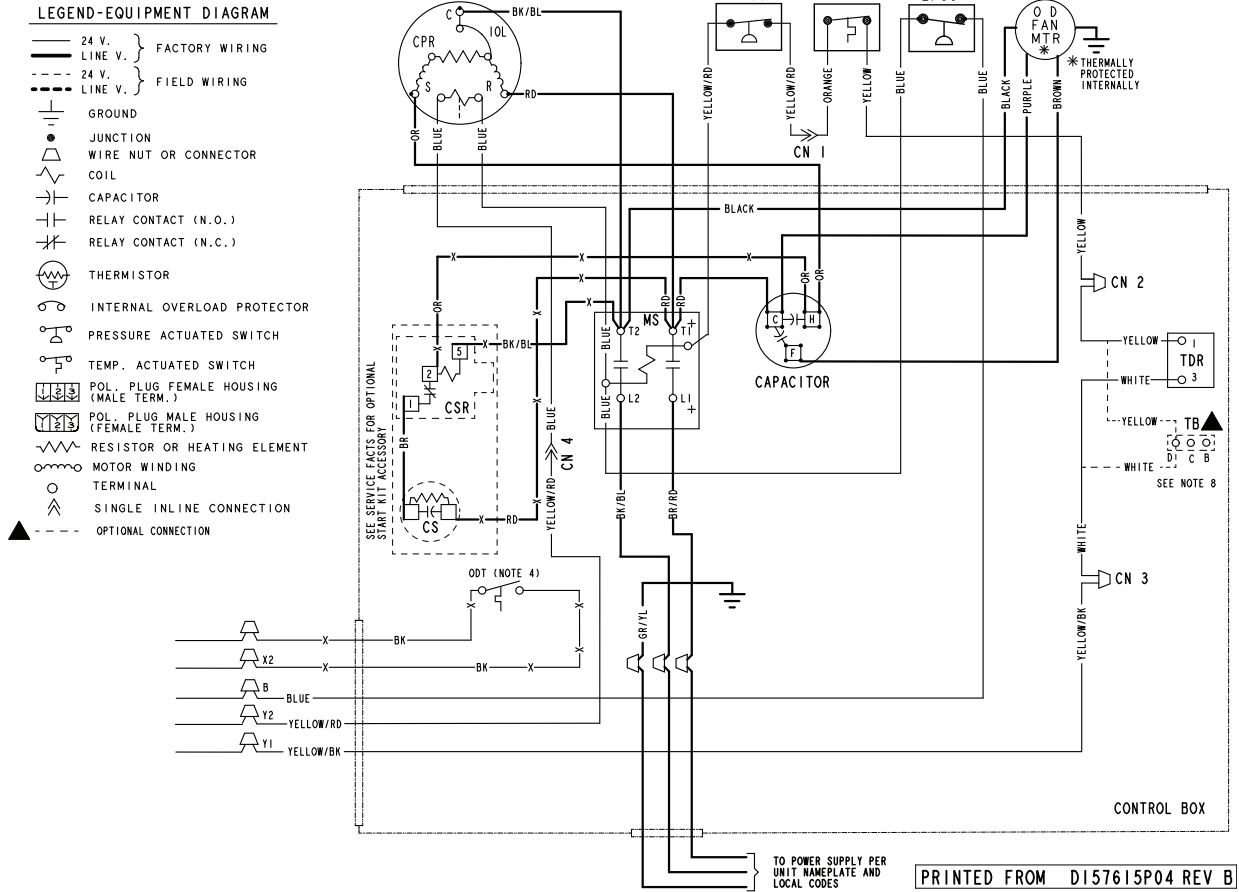

Figure 3. 048N Models

TO POWER SUPPLY PER UNIT NAMEPLATE AND LOCAL CODES

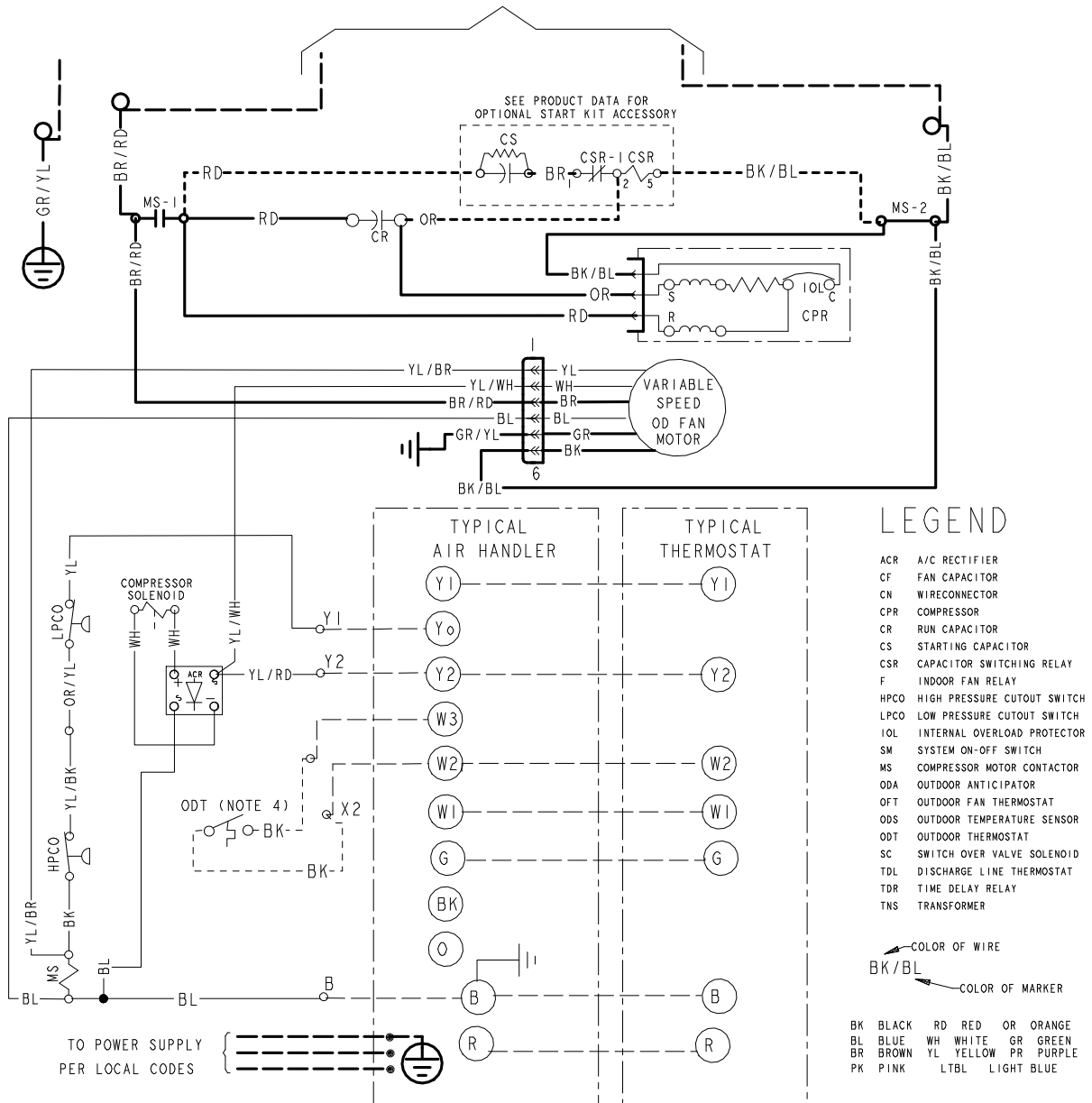
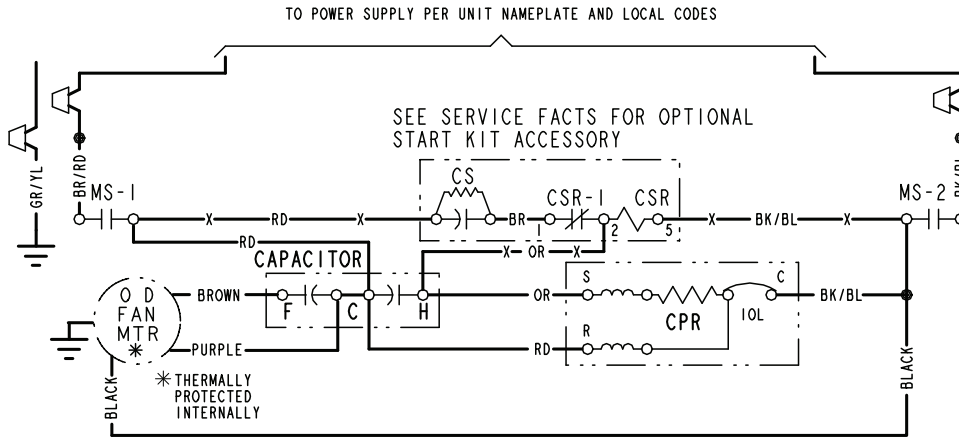



Figure 5. 060N Models



LEGEND

- CA COOLING ANTICIPATOR
- CBS COIL BOTTOM SENSOR
- CF FAN CAPACITOR
- CN WIRE CONNECTOR
- CPR COMPRESSOR
- CR RUN CAPACITOR
- CS STARTING CAPACITOR
- CSR CAPACITOR SWITCHING RELAY
- DFC DEFROST CONTROL
- F INDOOR FAN RELAY
- HA HEATING ANTICIPATOR
- HPCO HIGH PRESSURE CUTOUT SW.
- IOL INTERNAL OVERLOAD PROTECTOR
- ACR A/C RECTIFIER
- LPCO LOW PRESSURE CUTOUT SW.
- MS COMPRESSOR MOTOR CONTACTOR
- ODA OUTDOOR ANTICIPATOR
- OFT OUTDOOR FAN THERMOSTAT
- ODS OUTDOOR TEMPERATURE SENSOR
- ODT OUTDOOR THERMOSTAT
- RHS RESISTANCE HEAT SWITCH
- SC SWITCHOVER VALVE SOLENOID
- SM SYSTEM "ON-OFF" SWITCH
- TDL DISCHARGE LINE THERMOSTAT
- TDR TIME DELAY RELAY (5 SEC DELAY ON)
- TNS TRANSFORMER
- TS HEATING-COOLING THERMOSTAT
- TSH HEATING THERMOSTAT

- COLOR OF WIRE  
BK/BL BLACK WIRE WITH BLUE MARKER  
— COLOR OF MARKER
- |          |           |           |
|----------|-----------|-----------|
| BK BLACK | OR ORANGE | YL YELLOW |
| BL BLUE  | RD RED    | GR GREEN  |
| BR BROWN | WH WHITE  | PR PURPLE |

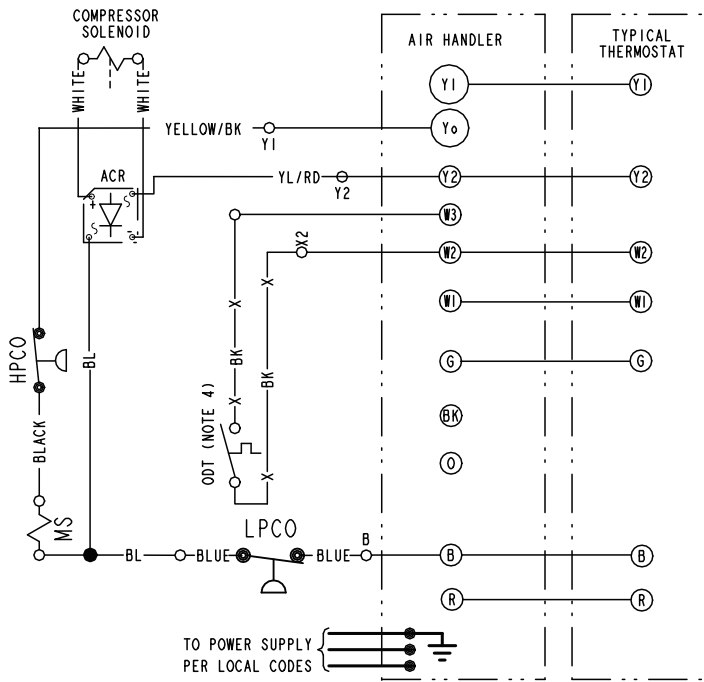

FOR CANADIAN INSTALLATIONS  
POUR INSTALLATIONS CANADIENNES

CAUTION: NOT SUITABLE FOR USE ON SYSTEMS EXCEEDING 150V-TO-GROUND.  
ATTENTION: NE CONVIENT PAS AUX INSTALLATIONS DE PLUS DE 150 V A LA TERRE.

<p><b>⚠ WARNING</b> HAZARDOUS VOLTAGE! DISCONNECT ALL ELECTRIC POWER INCLUDING REMOTE DISCONNECTS BEFORE SERVICING. FAILURE TO DISCONNECT POWER BEFORE SERVICING CAN CAUSE SEVERE PERSONAL INJURY OR DEATH!</p>	<p><b>⚠ CAUTION</b> USE COPPER CONDUCTORS ONLY! UNIT TERMINALS ARE NOT DESIGNED TO ACCEPT OTHER TYPES OF CONDUCTORS. FAILURE TO DO SO MAY CAUSE DAMAGE TO THE EQUIPMENT!</p>
-----------------------------------------------------------------------------------------------------------------------------------------------------------------------------------------------------------------------------	------------------------------------------------------------------------------------------------------------------------------------------------------------------------------------------

PRINTED FROM D157615P03 REV A

**Figure 6. 060N Models**

**NOTES:**

1. BE SURE POWER SUPPLY AGREES WITH EQUIPMENT NAMEPLATE.
2. POWER WIRING AND GROUNDING OF EQUIPMENT MUST COMPLY WITH LOCAL CODES.
3. LOW VOLTAGE WIRING TO BE NO. 18 AWG MINIMUM CONDUCTOR.
4. IF OUTDOOR THERMOSTAT (ODT) IS NOT USED, CONNECT W2 TO W3.
5. WITH Y1 ENERGIZED, INDOOR FAN IS 1ST STAGE AIRFLOW.
6. WITH Y1 & Y2 ENERGIZED, INDOOR FAN IS 2ND STAGE AIRFLOW.
7. SEE AIR HANDLER INSTALLER GUIDE FOR DIP SWITCH CONFIGURATIONS.

**LEGEND-EQUIPMENT DIAGRAM**

- 24 V. LINE V. } FACTORY WIRING
- - - 24 V. LINE V. } FIELD WIRING
- ⊥ GROUND
- JUNCTION
- WIRE NUT OR CONNECTOR
- ⊞ COIL
- ⊞ CAPACITOR
- ⊞ RELAY CONTACT (N.O.)
- ⊞ RELAY CONTACT (N.C.)
- ⊞ THERMISTOR
- ⊞ INTERNAL OVERLOAD PROTECTOR
- ⊞ PRESSURE ACTUATED SWITCH
- ⊞ TEMP. ACTUATED SWITCH
- ⊞ POL. PLUG FEMALE HOUSING (MALE TERM.)
- ⊞ POL. PLUG MALE HOUSING (FEMALE TERM.)
- ⊞ RESISTOR OR HEATING ELEMENT
- ⊞ MOTOR WINDING
- TERMINAL

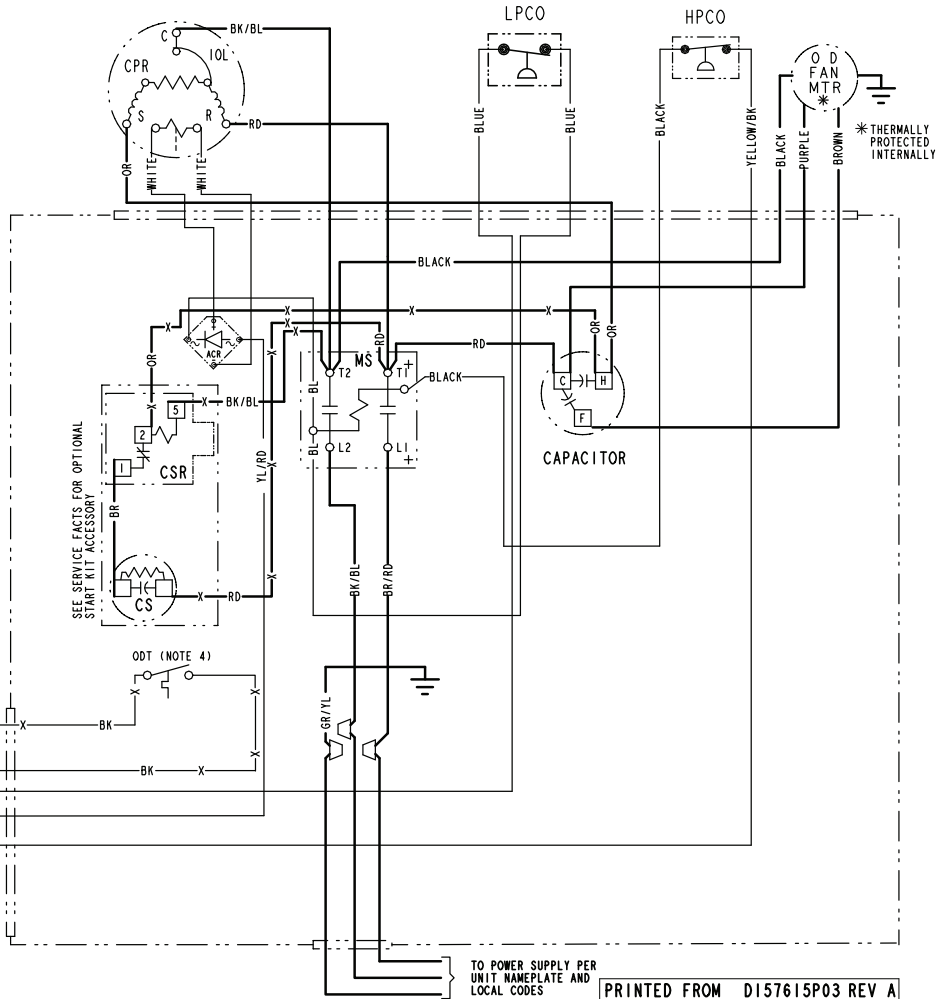

TO POWER SUPPLY PER UNIT NAMEPLATE AND LOCAL CODES **PRINTED FROM D157615P03 REV A**

Figure 7. 018J, 024J, 030J, 036J, 041J, 042J & 048J Models

TO POWER SUPPLY PER UNIT NAMEPLATE AND LOCAL CODES

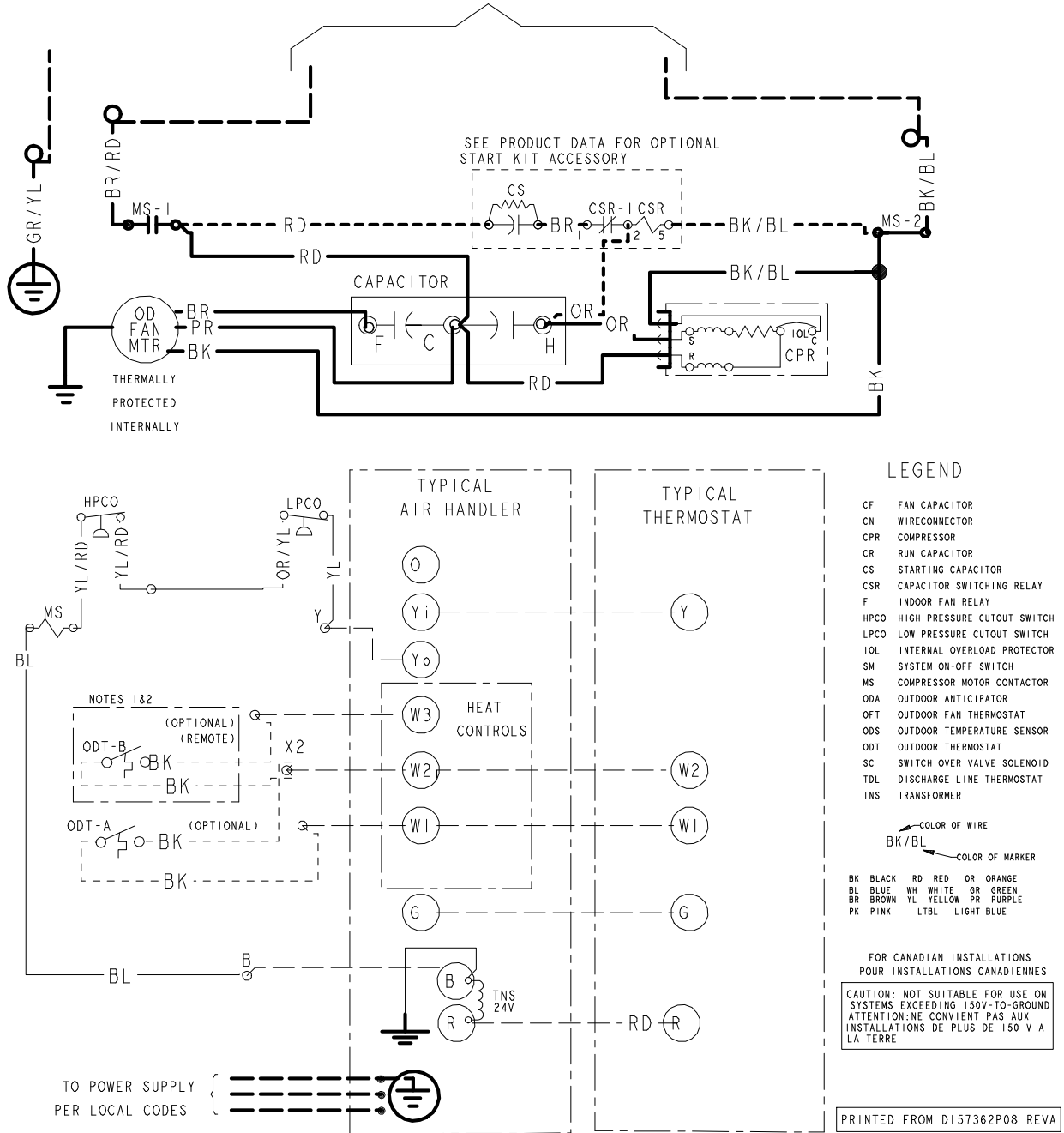

**Figure 8. 018J, 024J, 030J, 036J, 041J, 042J & 048J Models**

**NOTES:**

1. IF ODT-B IS NOT USED. ADD JUMPER BETWEEN W2 & W3 AT AIR HANDLER. IF USED, ODT-B MUST BE MOUNTED REMOTE OF CONTROL BOX IN AN APPROVED WEATHER PROOF ENCLOSURE.
2. IF ODT-A IS NOT USED. ADD JUMPER BETWEEN W1 & W2 AT AIR HANDLER.
3. LOW VOLTAGE (24 V) FIELD WIRING MUST BE 18 AWG MIN.

**LEGEND**

- 24 V FACTORY WIRING
- 24 V FIELD WIRING
- FIELD INSTALLED FACTORY WIRING
- MAGNETIC COIL
- GROUND
- JUNCTION
- CAPACITOR
- WIRE NUT OR
- TERMINAL
- TRANSFORMER
- FUSE
- TERMINAL BLOCK/BOARD
- RELAY CONTACT (N.O.)
- RELAY CONTACT (N.C.)
- THERMISTOR
- TEMP ACTUATED SWITCH
- INTERNAL OVERLOAD PROTECTION
- PRESSURE ACTUATED SWITCH
- RESISTOR OR HEATING ELEMENT
- MOTOR WINDING
- POL. PLUG FEMALE HOUSING (MALE TERMINALS)
- POL. PLUG MALE HOUSING (FEMALE TERMINALS)

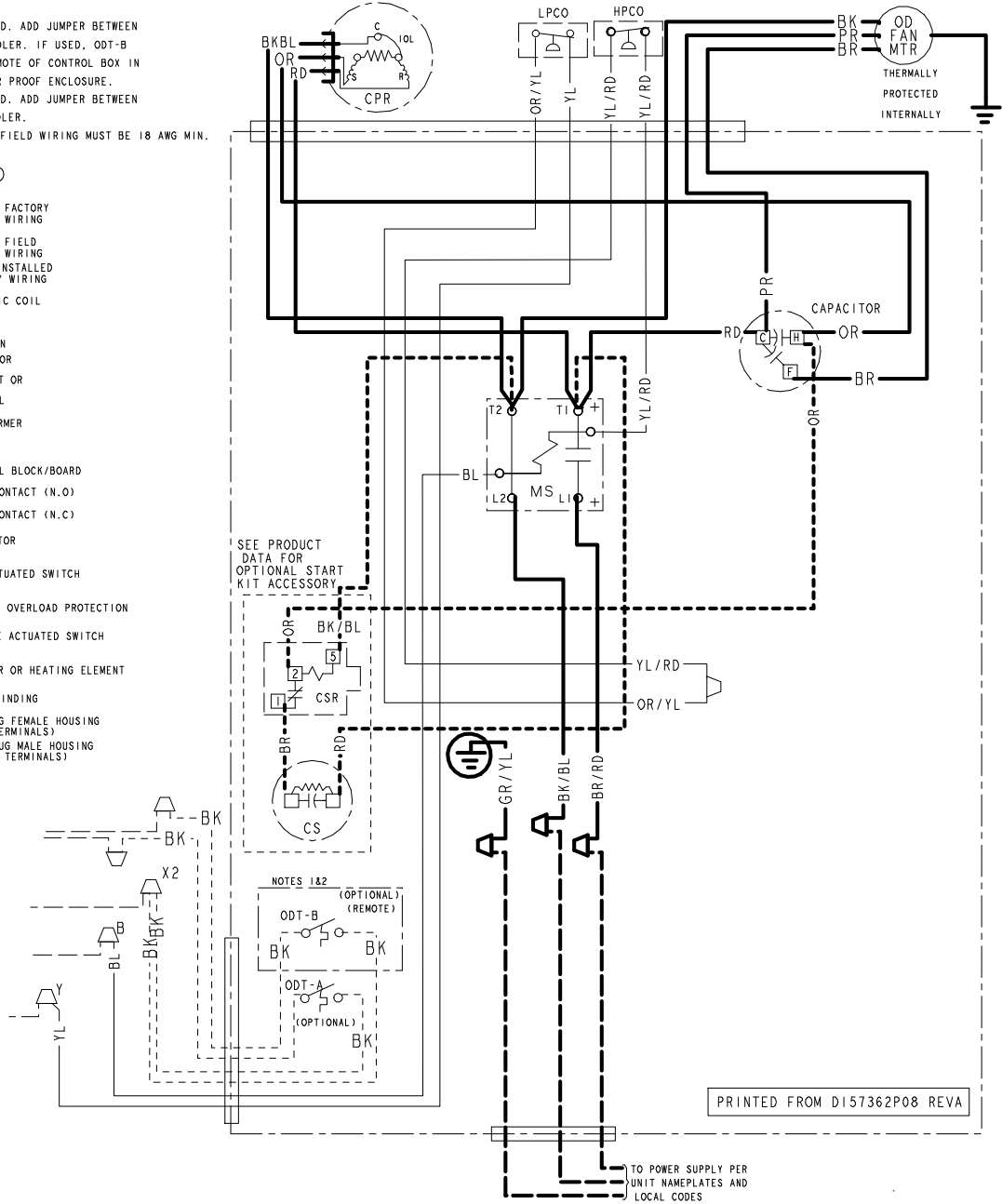
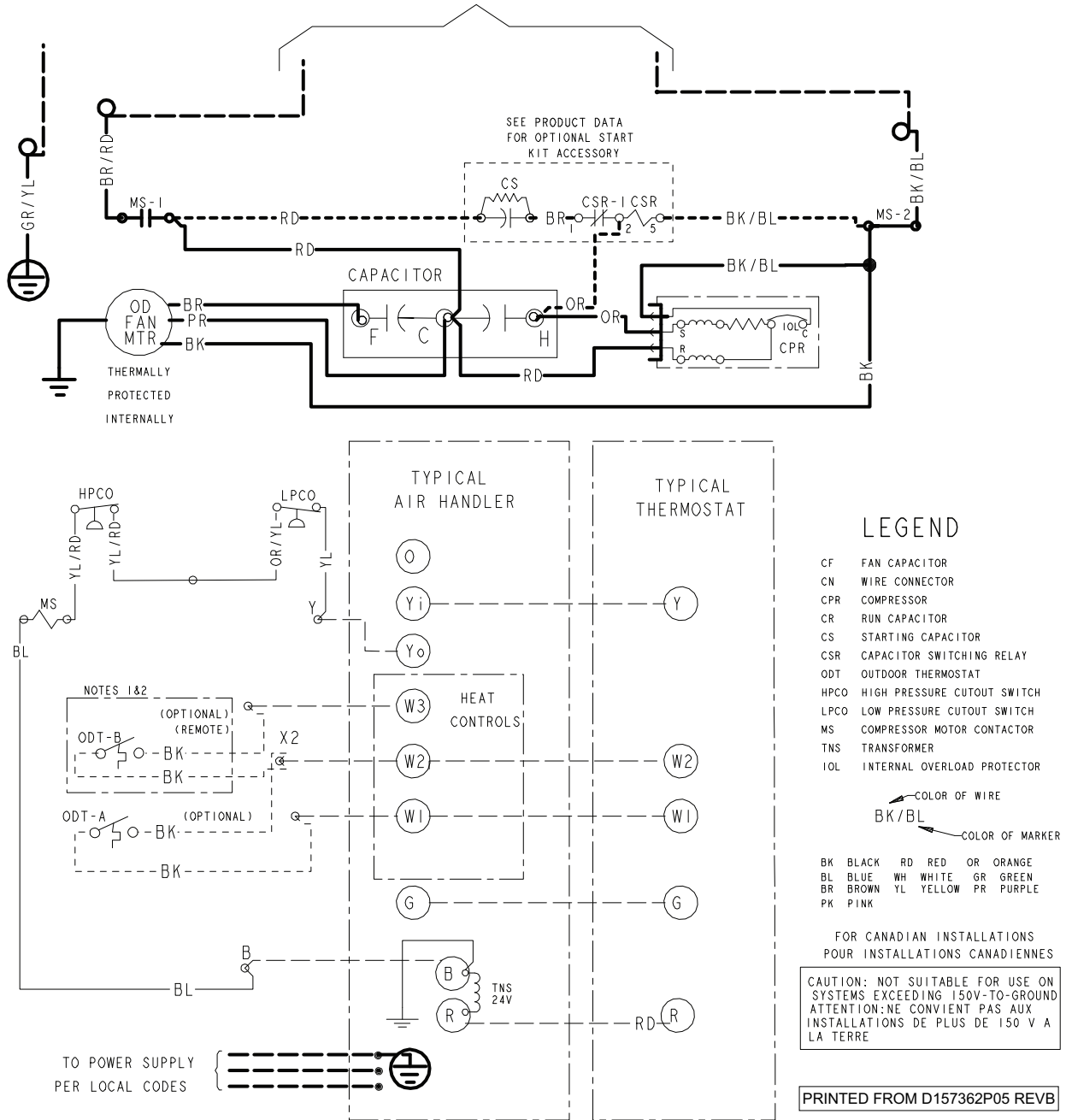

Figure 9. 035J Models

TO POWER SUPPLY PER UNIT NAMEPLATE AND LOCAL CODES



**Figure 10. 035J Models**

- NOTES:
1. IF ODT-B IS NOT USED, ADD JUMPER BETWEEN W2 & W3 AT AIR HANDLER. IF USED, ODT-B MUST BE MOUNTED REMOTE OF CONTROL BOX IN AN APPROVED WEATHER PROOF ENCLOSURE.
  2. IF ODT-A IS NOT USED, ADD JUMPER BETWEEN W1 & W2 AT AIR HANDLER.
  3. LOW VOLTAGE (24 V) FIELD WIRING MUST BE 18 AWG MINIMUM.
  4. USE COPPER CONDUCTORS ONLY!

LEGEND	
	24 V } FACTORY LINE V WIRING
	24 V } FIELD LINE V WIRING
	FIELD INSTALLED FACTORY WIRING
	MAGNETIC COIL
	GROUND
	JUNCTION
	CAPACITOR
	WIRE NUT OR
	TERMINAL
	TRANSFORMER
	TERMINAL BLOCK/BOARD
	RELAY CONTACT (N.O)
	RELAY CONTACT (N.C)
	THERMISTOR
	TEMP ACTUATED SWITCH
	INTERNAL OVERLOAD PROTECTION
	PRESSURE ACTUATED SWITCH
	RESISTOR OR HEATING ELEMENT
	MOTOR WINDING
	POL. PLUG FEMALE HOUSING (MALE TERMINALS)
	POL. PLUG MALE HOUSING (FEMALE TERMINALS)

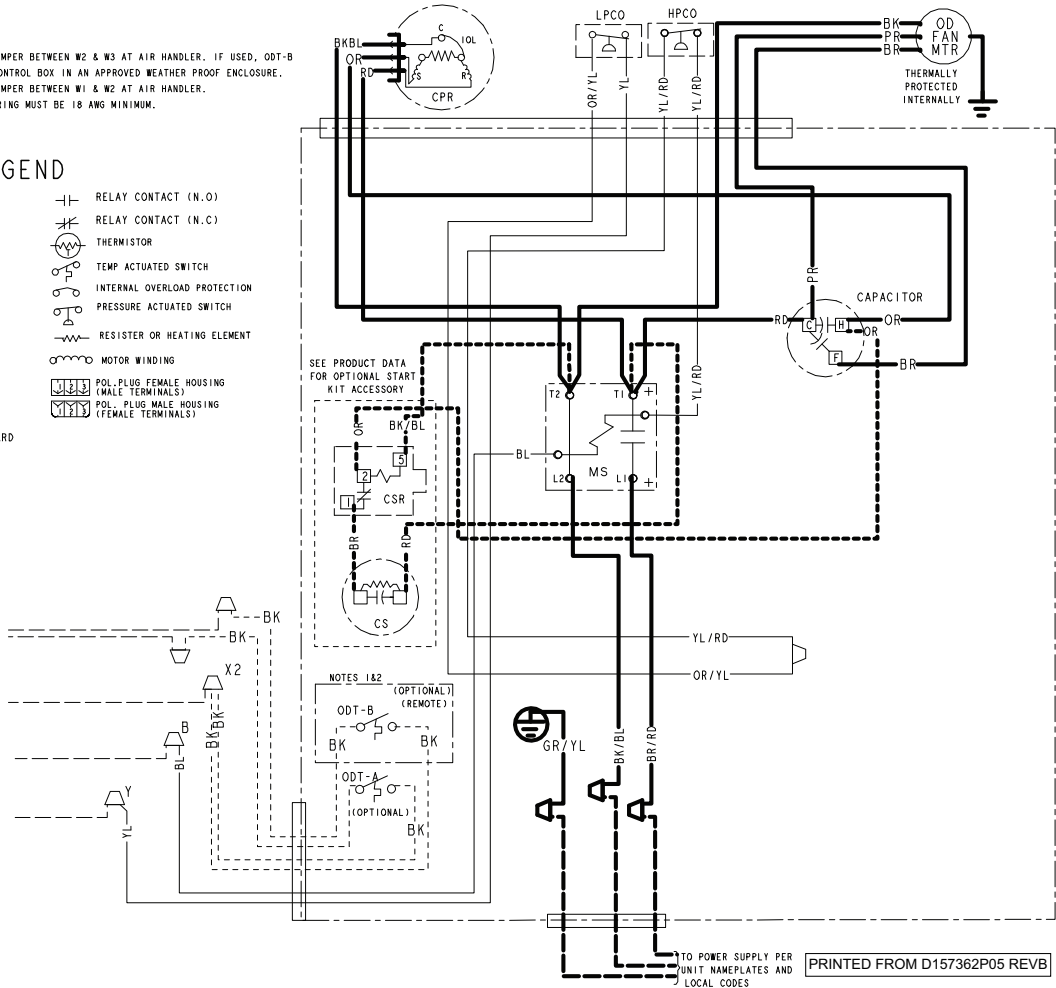







Schematic Diagrams

Figure 14. 060J & 060K Models

NOTES:

1. IF ODT-B IS NOT USED, ADD JUMPER BETWEEN W2 & W3 AT AIR HANDLER. IF USED, ODT-B MUST BE MOUNTED REMOTE OF CONTROL BOX IN AN APPROVED WEATHER PROOF ENCLOSURE.
2. IF ODT-A IS NOT USED, ADD JUMPER BETWEEN W1 & W2 AT AIR HANDLER.
3. LOW VOLTAGE (24 V) FIELD WIRING MUST BE 18 AWG MINIMUM.
4. USE COPPER CONDUCTORS ONLY!

LEGEND

- 24 V } FACTORY
- LINE } WIRING
- 24 V } FIELD
- LINE } WIRING
- X- 24 V } FIELD INSTALLED
- X- LINE } FACTORY WIRING
- ~ MAGNETIC COIL
- ⊥ GROUND
- JUNCTION
- ⊕ CAPACITOR
- ⊖ WIRE NUT OR CONNECTOR
- TERMINAL
- ⊞ TRANSFORMER
- TERMINAL BLOCK/BOARD
- ⊞ RELAY CONTACT (N.O.)
- ⊞ RELAY CONTACT (N.C.)
- ⊞ THERMISTOR
- ⊞ TEMP ACTUATED SWITCH
- ⊞ INTERNAL OVERLOAD PROTECTION
- ⊞ PRESSURE ACTUATED SWITCH
- ⊞ RESISTOR OR HEATING ELEMENT
- ⊞ MOTOR WINDING
- ⊞ P.O.L. PLUG FEMALE HOUSING (MALE TERMINALS)
- ⊞ P.O.L. PLUG MALE HOUSING (FEMALE TERMINALS)

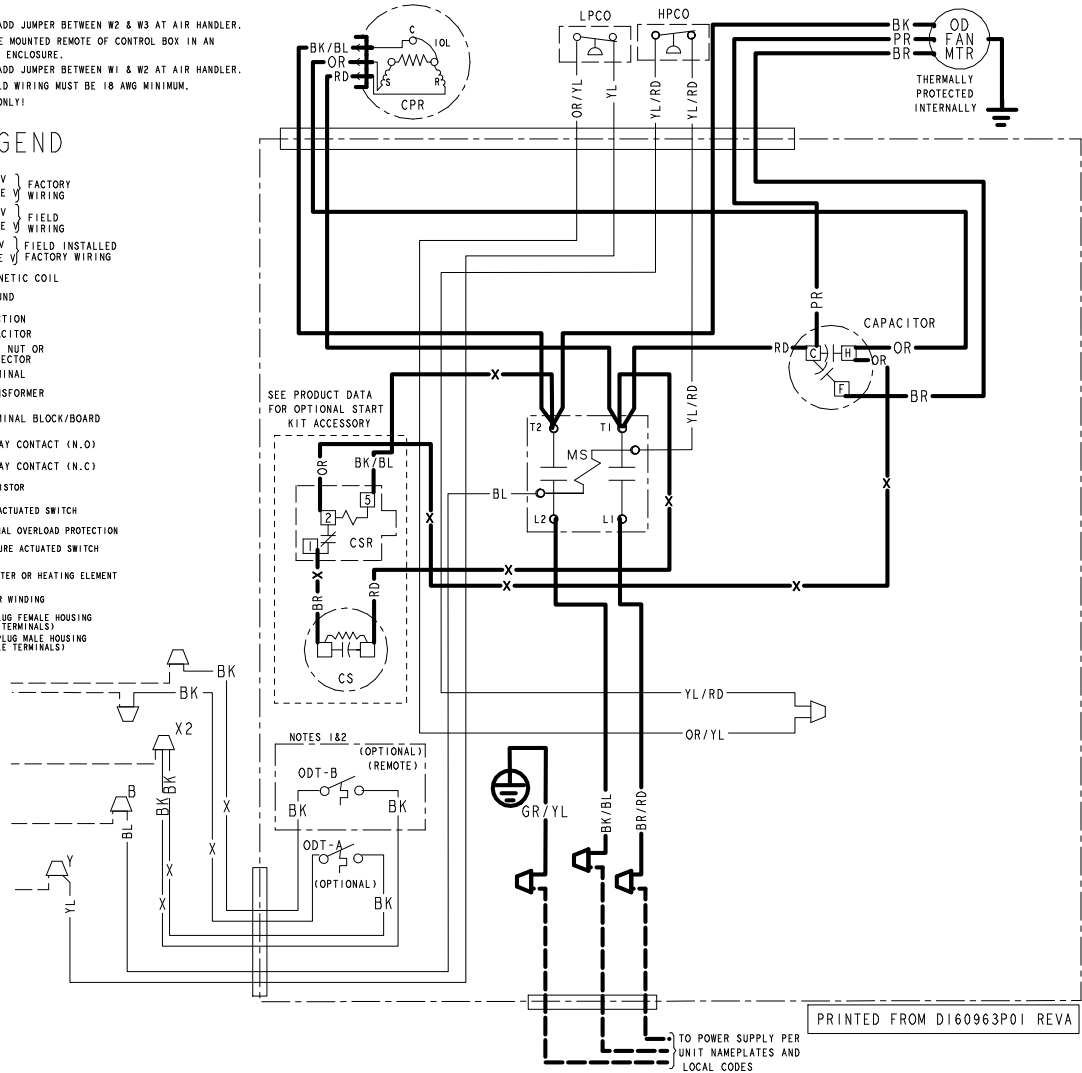

# Outline Drawing

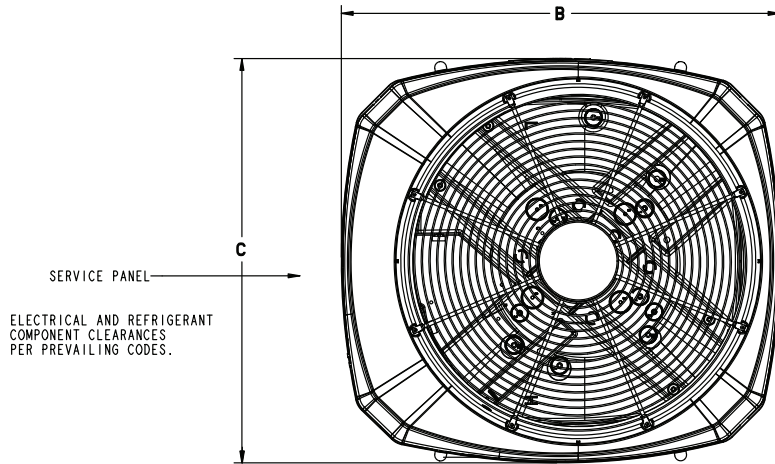

TOP DISCHARGE AREA SHOULD BE UNRESTRICTED FOR AT LEAST 1524 (5 FEET) ABOVE UNIT. UNIT SHOULD BE PLACED SO ROOF RUN-OFF WATER DOES NOT POUR DIRECTLY ON UNIT, AND SHOULD BE AT LEAST 305 (12") FROM WALL AND ALL SURROUNDING SHRUBBERY ON TWO SIDES. OTHER TWO SIDES UNRESTRICTED.

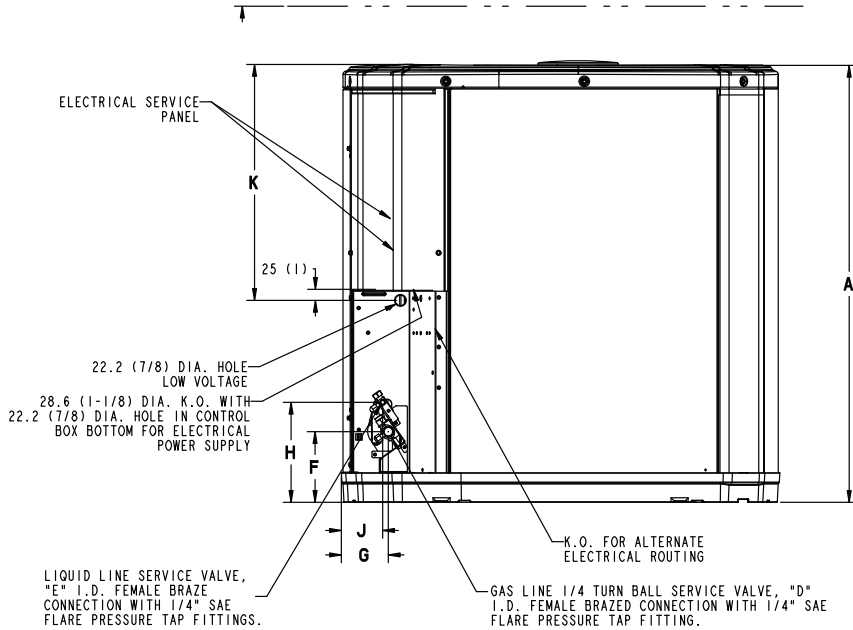

Model	Base	A	B	C	D	E	F	G	H	J	K
4A7A6024N	4	1045 (41-1/8)	946 (37-1/4)	870 (34-1/4)	3/4	3/8	152 (6)	98 (3-7/8)	219 (8-5/8)	86 (3-3/8)	711 (28)
4A7A6036N	4	1147 (45-1/8)	946 (37-1/4)	870 (34-1/4)	3/4	3/8	152 (6)	98 (3-7/8)	219 (8-5/8)	86 (3-3/8)	813 (32)
4A7A6048N	4	1147 (45-1/8)	946 (37-1/4)	870 (34-1/4)	7/8	3/8	152 (6)	98 (3-7/8)	219 (8-5/8)	86 (3-3/8)	813 (32)
4A7A6060N	4	1147 (45-1/8)	946 (37-1/4)	870 (34-1/4)	1-1/8	3/8	152 (6)	98 (3-7/8)	219 (8-5/8)	86 (3-3/8)	813 (32)

**Outline Drawing**

<b>Model</b>	<b>Base</b>	<b>A</b>	<b>B</b>	<b>C</b>	<b>D</b>	<b>E</b>	<b>F</b>	<b>G</b>	<b>H</b>	<b>J</b>	<b>K</b>
4A7A6018J	3	730 (28-3/4)	829 (32-5/8)	756 (29-3/4)	3/4	3/8	127 (5)	76 (3)	197 (7-3/4)	60 (2-3/8)	508 (20)
4A7A6024J	3	730 (28-3/4)	829 (32-5/8)	756 (29-3/4)	3/4	3/8	127 (5)	76 (3)	197 (7-3/4)	60 (2-3/8)	508 (20)
4A7A6030J	3	933 (36-3/4)	829 (32-5/8)	756 (29-3/4)	3/4	3/8	143 (5-5/8)	92 (3-5/8)	210 (8-1/4)	79 (3-1/8)	508 (20)
4A7A6035J	3	832 (32-3/4)	829 (32-5/8)	756 (29-3/4)	3/4	3/8	127 (5)	76 (3)	197 (7-3/4)	60 (2-3/8)	508 (20)
4A7A6036J	4	943 (37-1/8)	946 (37-1/4)	870 (34-1/4)	3/4	3/8	143 (5-5/8)	98 (3-7/8)	219 (8-5/8)	86 (3-3/8)	508 (20)
4A7A6041J	4	943 (37-1/8)	946 (37-1/4)	870 (34-1/4)	3/4	3/8	143 (5-5/8)	98 (3-7/8)	219 (8-5/8)	86 (3-3/8)	508 (20)
4A7A6042J	4	1147 (45-1/8)	946 (37-1/4)	870 (34-1/4)	7/8	3/8	152 (6)	98 (3-7/8)	219 (8-5/8)	86 (3-3/8)	813 (32)
4A7A6048J	4	1147 (45-1/8)	946 (37-1/4)	870 (34-1/4)	7/8	3/8	152 (6)	98 (3-7/8)	219 (8-5/8)	86 (3-3/8)	813 (32)
4A7A6049J	4	1147 (45-1/8)	946 (37-1/4)	870 (34-1/4)	7/8	3/8	152 (6)	98 (3-7/8)	219 (8-5/8)	86 (3-3/8)	813 (32)
4A7A6060J	4	1147 (45-1/8)	946 (37-1/4)	870 (34-1/4)	7/8	3/8	152 (6)	98 (3-7/8)	219 (8-5/8)	86 (3-3/8)	813 (32)
4A7A6060K	4	1147 (45-1/8)	946 (37-1/4)	870 (34-1/4)	7/8	3/8	152 (6)	98 (3-7/8)	219 (8-5/8)	86 (3-3/8)	813 (32)
4A7A6061C	4	1147 (45-1/8)	946 (37-1/4)	870 (34-1/4)	7/8	3/8	152 (6)	98 (3-7/8)	219 (8-5/8)	86 (3-3/8)	813 (32)

## Mechanical Specification Options

### General

The outdoor condensing units are factory charged with the system charge required for the outdoor condensing unit, ten (10) feet of tested connecting line, and the smallest rated indoor evaporative coil match. This unit is designed to operate at outdoor ambient temperatures as high as 115°F. Cooling capacities are matched with a wide selection of air handlers and furnace coils that are AHRI certified. The unit is certified to UL 1995. Exterior is designed for outdoor application.

### Casing

Unit casing is constructed of heavy gauge, galvanized steel and painted with a weather-resistant powder paint finish. The corner panels are prepainted. All panels are subjected to our 1,000 hour salt spray test.

### Refrigerant Controls

Refrigeration system controls include condenser fan, compressor contactor and low and high pressure switches. A factory supplied, field installed liquid line drier is standard.

### Compressor

The compressor features internal over temperature and pressure protection. Other features include: Centrifugal oil pump and low vibration and noise.

### Condenser Coil

The outdoor coil provides low airflow resistance and efficient heat transfer. The coil is protected on all four sides by louvered panels.

### Low Ambient Cooling

As manufactured, this system has a cooling capacity to 55°F. The addition of an evaporator defrost control permits operation to 40°F. The addition of an evaporator defrost control with TXV permits low ambient cooling to 30°F.

The addition of the BAYLOAM107A low ambient kit permits ambient cooling to 20°F.

**Thermostats** – Cooling only and heat/cooling (manual and automatic change over). Sub-base to match thermostat and locking thermostat cover.

## Notes

---



*American Standard*<sup>®</sup>  
HEATING & AIR CONDITIONING

#### About American Standard Heating and Air Conditioning

American Standard has been creating comfortable and affordable living environments for more than a century. For more information, please visit [www.americanstandardair.com](http://www.americanstandardair.com).



The AHRI Certified mark indicates company participation in the AHRI Certification program. For verification of individual certified products, go to [ahridirectory.org](http://ahridirectory.org).

The manufacturer has a policy of continuous data improvement and it reserves the right to change design and specifications without notice. We are committed to using environmentally conscious print practices.

12-1376-1M-EN 05 Aug 2022  
Supersedes 12-1376-1L-EN (January 2022)

©2022 American Standard Heating and Air Conditioning