

TECHNICAL GUIDE

TECHNICAL GUIDE

SINGLE PIECE PSC AIR HANDLERS

FOR USE WITH SPLIT-SYSTEM COOLING & HEAT PUMPS

MODELS: RFCX*P2 SERIES



Due to continuous product improvement, specifications are subject to change without notice.

Visit us on the web at:

www.upgnet.com

Additional rating information can be found at:

www.ahridirectory.org

WARRANTY

Standard 5-year limited parts warranty.

Extended 10-year limited parts warranty when product is registered online within 90 days of purchase for replacement or closing for new home construction.

DESCRIPTION

This fan coil line offers the ultimate in application flexibility. This unit may be used for upflow, downflow, horizontal right, or horizontal left applications.

All JCI Unitary Products air handlers and coils can use a TXV to provide our customers with the optimum performance and refrigerant control. Single piece air handlers are shipped with "Flex-coils" without a factory installed metering device. For added flexibility, an R-22 or R-410A TXV or orifice must be field installed to meet the requirement of the desired refrigerant.

FEATURES

RC² - Rigid Case Construction interior endoskeleton for structural support, smooth side, and locks in insulation.

Powder-painted - G30 galvanized steel case provide a coated edge that resists corrosion and rust creep.

MaxAlloy™ Coil - Long life aluminum coils built to deliver lasting performance, efficiency and reliability.

Quality Construction - Structural components are made of Aluminum or G90 galvanized steel to prevent corrosion.

Improved Insulation Design - Single piece with no external screws to reduce thermal transmission paths to prevent sweating. Foil faced insulation for ease of cleaning.

Thermostatic Expansion Valve - The accessory chatleff style TXV provides easy installation to convert the indoor coil to the required refrigerant that does not require brazing to replace or install.

Case Depth - These models have 20.5" casing which provide ease of attic access and tight applications.

Thermoset Drain Pan - Positive slope for drainage to reduce cause for potential mold or contaminants.

Low air Leakage - Cabinet design minimizes loss and infiltration.

Enhanced Filter Rack - All models have integrated internal filter racks provided for use with 1" thick standard size filters.

Electric Heat Kits - 6HK series of field installed electric heat kits are available for installation-friendly and easy service applications.

Blowers - All models use direct-drive, multi-speed PSC motors.

LIST OF SECTIONS

DESCRIPTION 1
 FEATURES 1
 NOMENCLATURE 2
 DIMENSIONS 3
 COIL TECHNICAL DATA 3
 COOLING CAPACITY 4
 PHYSICAL & ELECTRICAL DATA - COOLING ONLY 5
 ELECTRICAL DATA - COOLING ONLY 5
 ELECTRICAL HEAT - MINIMUM FAN SPEED 6
 ELECTRIC HEAT PERFORMANCE DATA:
 208/230-1-60 & 208/230-3-60 6
 ELECTRICAL DATA FOR SINGLE SOURCE
 POWER SUPPLY: 208/230-1-60 7
 ELECTRICAL DATA FOR MULTI-SOURCE
 POWER SUPPLY: 208/230-1-60 9
 ELECTRICAL DATA FOR SINGLE SOURCE
 POWER SUPPLY: 208/230-3-60 10
 ELECTRICAL DATA FOR MULTI-SOURCE
 POWER SUPPLY: 208/230-3-60 11
 AIR FLOW DATA (CFM) 11
 kW & MBH CONVERSIONS - FOR TOTAL
 POWER INPUT REQUIREMENT 12
 APPLICATION FACTORS - RATED CFM VS. ACTUAL CFM ... 12
 BLOWER SPEED CONNECTIONS 13
 ACCESSORIES 13
 POWER WIRING - LINE CONNECTIONS 13
 TYPICAL THERMOSTAT CONNECTION 14
 COMBUSTIBLE FLOOR BASE ACCESSORY 15
 LIMITATIONS 15
 TYPICAL APPLICATIONS 15

NOMENCLATURE

BRAND	R	R = OTC Factory Branded
PRODUCT TYPE	FC	FC = Fan Coil
TXV INDICATOR	X	BA-BF = Valve Size
		X = Flex Coil
NOMINAL UNIT CAPACITY	36	18 = 1.5 Ton 42 = 3.5 Ton
		24 = 2 Ton 48 = 4-Ton
		30 = 2.5 Ton 60 = 5-Ton
		36 = 3 Ton
CABINET WIDTH	B	A = 14.5"
		B = 17.5"
		C = 21.0"
		D = 24.5"
MOTOR TYPE	P	P = PSC
		E = STANDARD ECM
AIRFLOW	14	06 = 600
		08 = 800
		10 = 1000
		12 = 1200
		14 = 1400
		16 = 1600
20 = 2000		
CONFIGURATION	MP	MP = Multi-position
VOLTAGE (Voltage-Phase-Hertz)	2	2 = 208/230-1-60
GENERATION (MAJOR REVISION)	1	1 = 1st Gen 2 = 2nd Gen etc.
STYLE LETTER (MINOR REVISION) NOT USED FOR ORDERING	A	A = Style A B = Style B etc.

DIMENSIONS & DUCT CONNECTION DIMENSIONS

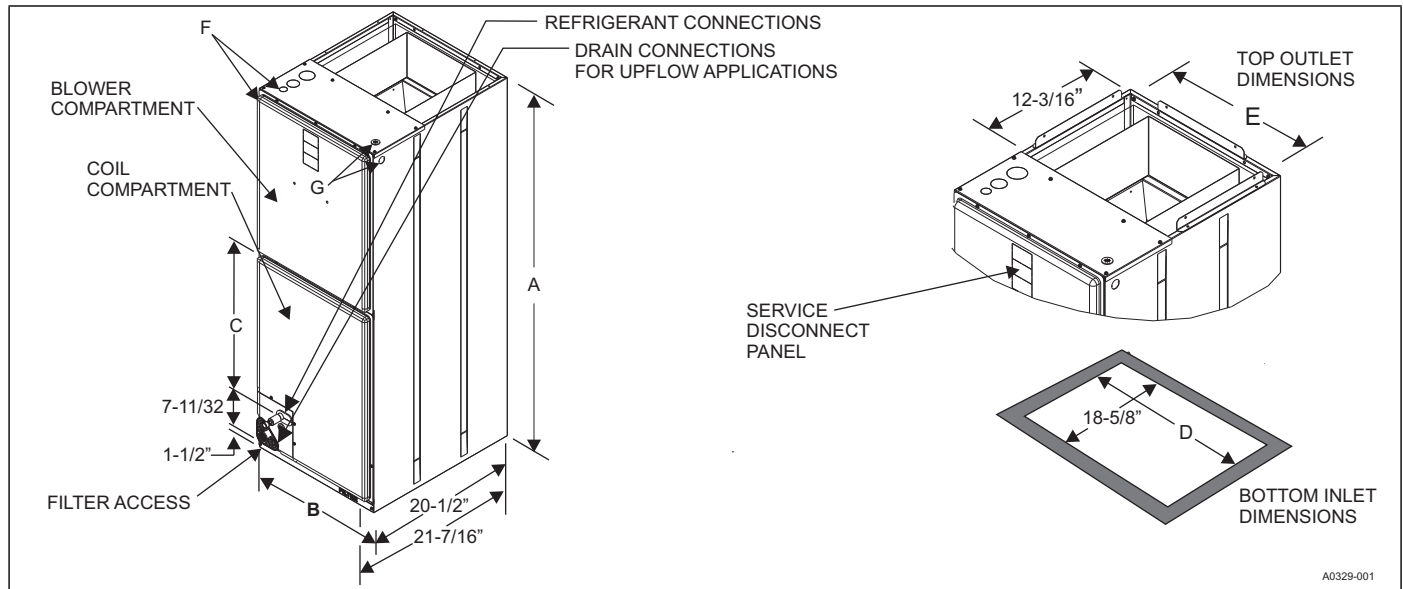

DIMENSIONS

Models	Dimensions ¹					Wiring Knockouts ²		Refrigerant Connections Line Size	
	A	B	C	D	E	F	G	Liquid	Vapor
	Height	Width				Power (Conduit)	Control (Conduit)		
RFCX18BP06MP22	41	17-1/2	12-7/8	14-1/4	16-1/2	7/8 (1/2) 1-3/8 (1) 1-23/32 (1-1/4)	7/8 (1/2)	3/8	3/4
RFCX24BP08MP22	41	17-1/2	12-7/8	14-1/4	16-1/2				
RFCX30BP10MP22	47-1/2	17-1/2	19-1/2	14-1/4	16-1/2				
RFCX36BP12MP22	47-1/2	17-1/2	19-1/2	14-1/4	16-1/2				
RFCX36CP12MP22	51-1/2	21	22-5/8	17-3/4	20				
RFCX37CP14MP22	51-1/2	21	22-5/8	17-3/4	20				
RFCX42CP14MP22	51-1/2	21	22-5/8	17-3/4	20			7/8	7/8
RFCX48CP16MP22	51-1/2	21	22-5/8	17-3/4	20				
RFCX48DP16MP22	55-1/2	24-1/2	26-5/8	21-1/4	23-1/2				
RFCX60CP20MP23	55-3/4	21	26-7/8	17-3/4	20				
RFCX60DP20MP24	55-1/2	24-1/2	26-5/8	21-1/4	23-1/2				

1. All dimensions are in inches.

2. Knockout size (conduit size in parentheses).

COIL TECHNICAL DATA

Models	Application	Refrig. Conn. Types	Face Area (Sq. Ft.)	Rows Deep	Fins Per In.	Coil Size	Tube Geometry	Tube Dia.	Fin Type
RFCX18BP06MP22	Cooling /Heat Pump	Sweat	4.3	2	14	(3) 12 x 17.1	1 x 0.866	3/8	Sine Wave
RFCX24BP08MP22	Cooling /Heat Pump	Sweat	5.0	2	14	(3) 14 x 17.1	1 x 0.866	3/8	Sine Wave
RFCX30BP10MP22	Cooling /Heat Pump	Sweat	7.1	2	14	(3) 20 x 17.1	1 x 0.866	3/8	Sine Wave
RFCX36BP12MP22	Cooling /Heat Pump	Sweat	7.1	2	14	(3) 20 x 17.1	1 x 0.866	3/8	Sine Wave
RFCX36CP12MP22	Cooling /Heat Pump	Sweat	7.8	2	14	(3) 22 x 17.1	1 x 0.866	3/8	Sine Wave
RFCX37CP14MP22	Cooling /Heat Pump	Sweat	8.6	2	14	(3) 24 x 17.1	1 x 0.866	3/8	Sine Wave
RFCX42CP14MP22	Cooling /Heat Pump	Sweat	7.8	2	14	(3) 22 x 17.1	1 x 0.866	3/8	Sine Wave
RFCX48CP16MP22	Cooling /Heat Pump	Sweat	8.6	2	14	(3) 24 x 17.1	1 x 0.866	3/8	Sine Wave
RFCX48DP16MP22	Cooling /Heat Pump	Sweat	8.6	2	14	(3) 24 x 17.1	1 x 0.866	3/8	Sine Wave
RFCX60CP20MP23	Cooling /Heat Pump	Sweat	10.0	2	14	(3) 28 x 17.1	1 x 0.866	3/8	Sine Wave
RFCX60DP20MP24	Cooling /Heat Pump	Sweat	10.0	2	14	(3) 28 x 17.1	1 x 0.866	3/8	Sine Wave

COOLING CAPACITY¹

Models	Rated CFM ²	Entering Air Dry/Wet Bulb (°F)	MBH@ Evap. Temp. and Corresponding R-410A Pressure (°F/PSIG)			
			35/107.9	40/118.9	45/130.7	50/143.3
18B	600	85/72	45.7	41.6	36.8	30.5
		80/67	38.5	33.9	28.5	22.3
		75/62	31.5	26.5	20.5	15.9
		70/57	24.4	19.5	15.2	11.5
24B	800	85/72	52.2	47.5	41.8	35.0
		80/67	43.6	38.3	31.9	24.5
		75/62	35.2	29.5	22.7	16.2
		70/57	27.1	20.7	15.5	11.4
30B	1000	85/72	82.1	73.7	64.1	54.4
		80/67	68.6	60.1	50.5	39.5
		75/62	56.3	47.0	37.3	29.2
		70/57	43.5	36.0	28.3	21.6
36B	1200	85/72	91.6	82.4	71.3	59.4
		80/67	76.5	65.4	54.6	42.8
		75/62	61.3	51.2	40.0	30.5
		70/57	47.5	38.1	28.7	22.3
36C	1200	85/72	98.0	88.6	77.4	66.4
		80/67	82.6	72.6	61.7	50.6
		75/62	68.5	57.6	47.5	36.6
		70/57	53.9	44.8	35.0	28.4
37C	1200	85/72	90.8	82.1	73.1	62.5
		80/67	76.1	67.4	57.0	44.8
		75/62	62.2	53.0	42.3	30.6
		70/57	49.3	39.2	29.0	22.6
42C	1400	85/72	100.6	89.8	78.2	64.7
		80/67	83.5	73.7	59.8	48.0
		75/62	67.8	55.8	44.7	32.5
		70/57	52.3	41.5	30.7	23.7
48C	1600	85/72	115.2	105.0	93.9	79.0
		80/67	88.3	78.2	65.5	52.6
		75/62	72.7	60.8	50.1	37.6
		70/57	57.7	46.9	36.6	29.7
48D	1600	85/72	115.2	105.0	93.9	79.0
		80/67	88.3	78.2	65.5	52.6
		75/62	72.7	60.8	50.1	37.6
		70/57	57.7	46.9	36.6	29.7
60C	1800	85/72	115.1	103.0	91.7	78.6
		80/67	96.8	85.9	73.7	60.5
		75/62	80.7	69.4	57.5	43.5
		70/57	58.7	48.9	37.7	32.7
60D	1800	85/72	115.1	103.0	91.7	78.6
		80/67	96.8	85.9	73.7	60.5
		75/62	80.7	69.4	57.5	43.5
		70/57	58.7	48.9	37.7	32.7

1. Actual capacity varies with the outdoor AC or HP that is used with the system.
2. Airflow is calculated for each system tonnage.

PHYSICAL & ELECTRICAL DATA - COOLING ONLY

Models		18B	24B	30B	36B	36C	37C
Blower - Diameter x Width		10 x 8	10 x 8	10 x 8	10 x 8	10 x 10	10 x 10
Motor	HP	1/8 HP	1/4 HP	1/3 HP	1/2 HP	1/2 HP	1/2 HP
	Nominal RPM	867	850	950	1085	1050	1050
Voltage		208/230	208/230	208/230	208/230	208/230	208/230
Full Load Amps @230V		1.0	1.4	2.3	2.6	2.2	2.2
Filter ¹	Type	DISPOSABLE OR PERMANENT					
	Size	16 x 20 x 1	16 x 20 x 1	16 x 20 x 1	16 x 20 x 1	20 x 20 x 1	20 x 20 x 1
	Permanent Type Kit	1PF0601	1PF0601	1PF0601	1PF0601	1PF0602	1PF0602
Shipping/Operating Weight (lbs.)		91/85	93/87	119/113	119/113	120/114	158/150
Models		42C	48C	48D	60C	60D	
Blower - Diameter x Width		10 x 10	10 x 10	10 x 10	10 x 10	10 x 10	
Motor	HP	1/2 HP	1/2 HP	1/2 HP	1 HP	1 HP	
	Nominal RPM	1085	1040	1040	1007	1007	
Voltage		208/230	208/230	208/230	208/230	208/230	
Full Load Amps @230V		2.8	2.9	2.9	4.1	4.4	
Filter ¹	Type	DISPOSABLE OR PERMANENT					
	Size	20 x 20 x 1	20 x 20 x 1	22 x 20 x 1	20 x 20 x 1	22 x 20 x 1	
	Permanent Type Kit	1PF0602	1PF0602	1PF0603	1PF0602	1PF0603	
Shipping/Operating Weight (lbs.)		144/136	158/150	163/153	156/146	180/170	

1. Field supplied.

ELECTRICAL DATA - COOLING ONLY

Models	Motor FLA ¹	Minimum Circuit Ampacity	MOP ²
18B	1.1	1.4	15
24B	1.4	1.8	15
30B	2.3	2.9	15
36B	2.6	3.3	15
36C/37C	2.2	2.8	15
42C	2.8	3.5	15
48C/48D	2.9	3.6	15
60C	4.1	5.1	15
60D	4.4	5.5	15

1. FLA = Full Load Amps

2. MOP = Maximum Overcurrent Protection device; must be HACR type service disconnect or time delay fuse. Refer to the latest edition of the National Electric Code or in Canada the Canadian electrical Code and local codes to determine correct wire sizing.

ELECTRICAL HEAT - MINIMUM FAN SPEED

Heater Kit Models ^{1,2,3}	Nom. kW@240V	Air Handler Models											
		18B	24B	30B	36B	36C	37C	42C	48C	48D	60C	60D	
6HK(0,1)6500206	2.4kW	Med	Low	Low	Low	Low	Low	Low	Low	Low	Low	Low	Low
6HK(0,1)6500506	4.8kW	Med	Low	Low	Low	Low	Low	Low	Low	Low	Low	Low	Low
6HK(0,1)6500806	7.7kW	High	High	Med	Low	Low	Low	Low	Low	Low	Low	Low	Low
6HK(0,1)6501006 6HK36501025	9.6kW	High	High	Med	Low	Low	Low	Low	Low	Low	Low	Low	Low
6HK(1,2)6501306	12.5kW	-	High	Med	Low	Med	Med	Low	Low	Low	Low	Low	Med
6HK(1,2)6501506 6HK36501525	14.4kW	-	-	Med	Low	Med	Med	Med	Low	Low	Low	Low	Med
6HK(1,2)6501806 6HK36501825	17.3kW	-	-	-	Low	Med	Med	Med	Low	Low	Low	Low	High
6HK(1,2)6502006 6HK46502025	19.2kW	-	-	-	Low	High	High	Med	Med	Med	High	High	High
6HK(1,2)6502506 6HK46502525	24kW	-	-	-	-	-	-	-	-	-	Med	-	High

- (0,1) - 0 = no service disconnect OR 1 = with service disconnect.
- (1,2) - 1 = with service disconnect, no breaker jumper bar OR 2 = with service disconnect & breaker jumper bar.
- 6HK3 = 3-Phase with terminal block connectors only, 6HK4 = 3-Phase with service disconnect.

ELECTRIC HEAT PERFORMANCE DATA: 208/230-1-60 & 208/230-3-60

Heater Models ^{1,2,3}		Nominal kW @240V	Total Heat ⁴				kW Staging			
			kW		MBH		W1 Only		W1 + W2	
			208V	230V	208V	230V	208V	230V	208V	230V
1PH	6HK(0,1)6500206	2.4	1.8	2.2	6.2	7.5	1.8	2.2	1.8	2.2
	6HK(0,1)6500506	4.8	3.6	4.4	12.3	15	3.6	4.4	3.6	4.4
	6HK(0,1)6500806	7.7	5.8	7.1	19.7	24.1	5.8	7.1	5.8	7.1
	6HK(0,1)6501006	9.6	7.2	8.8	24.6	30.1	7.2	8.8	7.2	8.8
	6HK(1,2)6501306	12.5	9.4	11.5	32	39.2	3.1	3.8	9.4	11.5
	6HK(1,2)6501506	14.4	10.8	13.2	36.9	45.1	3.6	4.4	10.8	13.2
	6HK(1,2)6501806	17.3	13	15.9	44.3	54.2	6.5	7.9	13	15.9
	6HK(1,2)6502006	19.2	14.4	17.6	49.2	60.2	7.2	8.8	14.4	17.6
	6HK(1,2)6502506	24	18	22	61.5	75.2	7.2	8.8	18	22
3PH	6HK36501025	9.6	7.2	8.8	24.6	30.1	7.2	8.8	7.2	8.8
	6HK36501525	14.4	10.8	13.2	36.9	45.1	10.8	13.2	10.8	13.2
	6HK36501825	17.3	13	15.9	44.3	54.2	13	15.9	13	15.9
	6HK46502025	19.2	14.4	17.6	49.2	60.2	7.2	8.8	14.4	17.6
	6HK46502525	24	18	22	61.5	75.2	9	11	18	22

- (0,1) - 0 = no service disconnect OR 1 = with service disconnect.
- (1,2) - 1 = with service disconnect, no breaker jumper bar OR 2 = with service disconnect & breaker jumper bar.
- 6HK3 = 3-Phase with terminal block connectors only, 6HK4 = 3-Phase with service disconnect.
- For different power distributions, see conversion table on Page 11.

ELECTRICAL DATA FOR SINGLE SOURCE POWER SUPPLY: 208/230-1-60

Air Handler Models	Heater Models ^{1,2}	Heater Amps @240V	Field Wiring			
			Min. Circuit Ampacity		MOP. ³	
			208V	230V	208V	230V
18B	6HK(0,1)6500206	10	12.2	13.3	15	15
	6HK(0,1)6500506	20	23.0	25.3	25	30
	6HK(0,1)6500806	32	36.2	40.0	40	40
	6HK(0,1)6501006	40	44.6	49.2	45	50
24B	6HK(0,1)6500206	10	12.6	13.7	15	15
	6HK(0,1)6500506	20	23.4	25.7	25	30
	6HK(0,1)6500806	32	36.6	40.3	40	45
	6HK(0,1)6501006	40	45.0	49.6	45	50
	6HK(1,2)6501306	52	58.2	64.3	60	70
30B	6HK(0,1)6500206	10	13.7	14.8	15	15
	6HK(0,1)6500506	20	24.5	26.8	25	30
	6HK(0,1)6500806	32	37.7	41.5	40	45
	6HK(0,1)6501006	40	46.1	50.7	50	60
	6HK(1,2)6501306	52	59.4	65.4	60	70
	6HK(1,2)6501506	60	67.8	74.6	70	80
36B	6HK(0,1)6500206	10	14.1	15.2	15	20
	6HK(0,1)6500506	20	24.9	27.2	25	30
	6HK(0,1)6500806	32	38.1	41.8	40	45
	6HK(0,1)6501006	40	46.5	51.1	50	60
	6HK(1,2)6501306	52	59.7	65.8	60	70
	6HK(1,2)6501506	60	68.2	75.0	70	80
	6HK(1,2)6501806	72	81.4	89.7	90	90
	6HK(1,2)6502006	80	89.8	98.9	90	100
36C	6HK(0,1)6500206	10	13.6	14.7	15	15
	6HK(0,1)6500506	20	24.4	26.7	25	30
	6HK(0,1)6500806	32	37.6	41.3	40	45
	6HK(0,1)6501006	40	46.0	50.6	50	60
	6HK(1,2)6501306	52	59.2	65.3	60	70
	6HK(1,2)6501506	60	67.7	74.5	70	80
	6HK(1,2)6501806	72	80.9	89.2	90	90
	6HK(1,2)6502006	80	89.3	98.4	90	100
37C	6HK(0,1)6500206	10	13.6	14.7	15	15
	6HK(0,1)6500506	20	24.4	26.7	25	30
	6HK(0,1)6500806	32	37.6	41.3	40	45
	6HK(0,1)6501006	40	46.0	50.6	50	60
	6HK(1,2)6501306	52	59.2	65.3	60	70
	6HK(1,2)6501506	60	67.7	74.5	70	80
	6HK(1,2)6501806	72	80.9	89.2	90	90
	6HK(1,2)6502006	80	89.3	98.4	90	100
42C	6HK(0,1)6500206	10	14.3	15.5	15	20
	6HK(0,1)6500506	20	25.1	27.4	30	30
	6HK(0,1)6500806	32	38.4	42.1	40	45
	6HK(0,1)6501006	40	46.8	51.3	50	60
	6HK(1,2)6501306	52	60.0	66.0	60	70
	6HK(1,2)6501506	60	68.4	75.2	70	80
	6HK(1,2)6501806	72	81.6	89.9	90	90
	6HK(1,2)6502006	80	90.0	99.2	90	100

Continued on next page.

ELECTRICAL DATA FOR SINGLE SOURCE POWER SUPPLY: 208/230-1-60 (Continued)

Air Handler Models	Heater Models ^{1,2}	Heater Amps @240V	Field Wiring			
			Min. Circuit Ampacity		MOP. ³	
			208V	230V	208V	230V
48C	6HK(0,1)6500206	10	14.4	15.6	15	20
	6HK(0,1)6500506	20	25.3	27.5	30	30
	6HK(0,1)6500806	32	38.5	42.2	40	45
	6HK(0,1)6501006	40	46.9	51.5	50	60
	6HK(1,2)6501306	52	60.1	66.1	70	70
	6HK(1,2)6501506	60	68.5	75.4	70	80
	6HK(1,2)6501806	72	81.8	90.0	90	90
	6HK(1,2)6502006	80	90.2	99.3	90	100
48D	6HK(0,1)6500206	10	14.4	15.6	15	20
	6HK(0,1)6500506	20	25.3	27.5	30	30
	6HK(0,1)6500806	32	38.5	42.2	40	45
	6HK(0,1)6501006	40	46.9	51.5	50	60
	6HK(1,2)6501306	52	60.1	66.1	70	70
	6HK(1,2)6501506	60	68.5	75.4	70	80
	6HK(1,2)6501806	72	81.8	90.0	90	90
	6HK(1,2)6502006	80	90.2	99.3	100	100
60C	6HK(0,1)6500206	10	15.9	17.1	20	20
	6HK(0,1)6500506	20	26.8	29.0	30	30
	6HK(0,1)6500806	32	40.0	43.7	40	45
	6HK(0,1)6501006	40	48.4	53.0	50	60
	6HK(1,2)6501306	52	61.6	67.6	70	70
	6HK(1,2)6501506	60	70.0	76.9	70	80
	6HK(1,2)6501806	72	83.3	91.5	90	100
	6HK(1,2)6502006	80	91.7	100.8	100	110
60D	6HK(0,1)6500206	10	16.3	17.5	20	20
	6HK(0,1)6500506	20	27.1	29.4	30	30
	6HK(0,1)6500806	32	40.4	44.1	45	45
	6HK(0,1)6501006	40	48.8	53.3	50	60
	6HK(1,2)6501306	52	62.0	68.0	70	70
	6HK(1,2)6501506	60	70.4	77.2	80	80
	6HK(1,2)6501806	72	83.6	91.9	90	100
	6HK(1,2)6502006	80	92.0	101.2	100	110
	6HK(1,2)6502506	100	113.7	125.1	125	150

1. (0,1) - maybe 0 (no service disconnect) or 1 (with service disconnect).

2. (1,2) maybe 1 (with service disconnect, no breaker jumper bar) or 2 (with service disconnect & breaker jumper bar).

3. MOP = Maximum Overcurrent Protection device; must be HACR type service disconnect or time delay fuse. Refer to the latest edition of the National Electric Code or in Canada the Canadian electrical Code and local codes to determine correct wire sizing.

ELECTRICAL DATA FOR MULTI-SOURCE POWER SUPPLY: 208/230-1-60

Air Handlers Models	Heater Models	Total Heater Amp@ 240V	Min. Circuit Ampacity						MOP ¹					
			208V			230V			208V			230V		
			Circuit						Circuit					
			1st ³	2nd	3rd	1st ³	2nd	3rd	1st ³	2nd	3rd	1st ³	2nd	3rd
24B	6HK16501306	52	20.5	37.6	–	22.5	41.5	–	25	40	–	25	45	–
30B	6HK16501306	52	21.7	37.6	–	23.6	41.5	–	25	40	–	25	45	–
	6HK16501506	60	24.5	43.3	–	26.8	47.9	–	25	45	–	30	50	–
36B	6HK16501306	52	22.0	37.6	–	24.0	41.5	–	25	40	–	25	45	–
	6HK16501506	60	24.9	43.3	–	27.2	47.9	–	25	45	–	30	50	–
	6HK16501806	72	42.3	39.0	–	46.4	43.1	–	45	40	–	50	45	–
	6HK16502006	80	46.6	43.3	–	51.2	47.9	–	50	45	–	60	50	–
36C	6HK16501306	52	21.5	37.6	–	23.5	41.5	–	25	40	–	25	45	–
	6HK16501506	60	24.4	43.3	–	26.7	47.9	–	25	45	–	30	50	–
	6HK16501806	72	41.8	39.0	–	45.9	43.1	–	45	40	–	50	45	–
	6HK16502006	80	46.1	43.3	–	50.7	47.9	–	50	45	–	60	50	–
37C	6HK16501306	52	21.5	37.6	–	23.5	41.5	–	25	40	–	25	45	–
	6HK16501506	60	24.4	43.3	–	26.7	47.9	–	25	45	–	30	50	–
	6HK16501806	72	41.8	39.0	–	45.9	43.1	–	45	40	–	50	45	–
	6HK16502006	80	46.1	43.3	–	50.7	47.9	–	50	45	–	60	50	–
42C	6HK16501306	52	22.3	37.6	–	24.3	41.5	–	25	40	–	25	45	–
	6HK16501506	60	25.2	43.3	–	27.5	47.9	–	30	45	–	30	50	–
	6HK16501806	72	34.7	39.0	–	46.6	43.1	–	40	40	–	50	45	–
	6HK16502006	80	38.2	43.3	–	51.4	47.9	–	40	45	–	60	50	–
48C	6HK16501306	52	22.4	37.6	–	24.4	41.5	–	25	40	–	25	45	–
	6HK16501506	60	25.3	43.3	–	27.6	47.9	–	30	45	–	30	50	–
	6HK16501806	72	42.6	39.0	–	46.8	43.1	–	45	40	–	50	45	–
	6HK16502006	80	47.0	43.3	–	51.5	47.9	–	50	45	–	60	50	–
48D	6HK16501306	52	22.4	37.6	–	24.4	41.5	–	25	40	–	25	45	–
	6HK16501506	60	25.3	43.3	–	27.6	47.9	–	30	45	–	30	50	–
	6HK16501806	72	42.6	39.0	–	46.8	43.1	–	45	40	–	50	45	–
	6HK16502006	80	47.0	43.3	–	51.5	47.9	–	50	45	–	60	50	–
	6HK16502506	100	47.0	43.3	21.7	51.5	59.9	24.0	50	45	25	60	60	25
60C	6HK16501306	52	23.9	37.6	–	25.9	41.5	–	25	40	–	30	45	–
	6HK16501506	60	26.8	43.3	–	29.1	47.9	–	30	45	–	30	50	–
	6HK16501806	72	44.1	39.0	–	48.3	43.1	–	45	40	–	50	45	–
	6HK16502006	80	48.5	43.3	–	53.0	47.9	–	50	45	–	60	50	–
60D	6HK16501306	52	24.3	37.6	–	26.3	41.5	–	25	40	–	30	45	–
	6HK16501506	60	27.2	43.3	–	29.5	47.9	–	30	45	–	30	50	–
	6HK16501806	72	44.5	39.0	–	48.6	43.1	–	45	40	–	50	45	–
	6HK16502006	80	48.8	43.3	–	53.4	47.9	–	50	45	–	60	50	–
	6HK16502506	100	48.8	43.3	21.7	53.4	59.9	24.0	50	45	25	60	60	25

1. MOP = Maximum Overcurrent Protection device; must be HACR type circuit breaker or time delay fuse. The 1st circuit includes blower motor amps. Refer to the latest edition of the National Electric Code or in Canada the Canadian electrical Code and local codes to determine correct wire sizing.

ELECTRICAL DATA FOR SINGLE SOURCE POWER SUPPLY: 208/230-3-60

Air Handler Models	Heater Models ¹	Heater Amps @240V	Field Wiring			
			Min. Circuit Ampacity		MOP. ²	
			208V	230V	208V	230V
18B	6HK36501025	23.1	26.4	29.4	30	30
24B	6HK36501025	23.1	26.8	29.4	30	30
30B	6HK36501025	23.1	27.9	30.5	30	35
	6HK36501525	34.6	40.4	44.3	45	45
36B	6HK36501025	23.1	28.3	30.9	30	35
	6HK36501525	34.6	40.8	44.7	45	45
	6HK36501825	41.6	48.4	53.2	50	55
	6HK46502025 ³	46.2	53.3	58.5	55	60
36C	6HK36501025	23.1	27.8	30.4	30	35
	6HK36501525	34.6	40.3	44.2	45	45
	6HK36501825	41.6	47.9	52.7	50	55
	6HK46502025 ³	46.2	52.8	58.0	55	60
37C	6HK36501025	23.1	27.8	30.4	30	35
	6HK36501525	34.6	40.3	44.2	45	45
	6HK36501825	41.6	47.9	52.7	50	55
	6HK46502025 ³	46.2	52.8	58.0	55	60
42C	6HK36501025	23.1	28.5	31.1	30	35
	6HK36501525	34.6	41.0	45.0	45	45
	6HK36501825	41.6	48.7	53.4	50	55
	6HK46502025 ³	46.2	53.5	58.8	55	60
48C	6HK36501025	23.1	28.6	31.3	30	35
	6HK36501525	34.6	41.1	45.1	45	50
	6HK36501825	41.6	48.8	53.6	50	55
	6HK46502025 ³	46.2	53.6	58.9	55	60
48D	6HK36501025	23.1	28.6	31.3	30	35
	6HK36501525	34.6	41.1	45.1	45	50
	6HK36501825	41.6	48.8	53.6	50	55
	6HK46502025 ³	46.2	53.6	58.9	55	60
	6HK46502525 ³	57.7	66.2	72.7	70	80
60C	6HK36501025	23.1	30.1	32.8	35	35
	6HK36501525	34.6	42.6	46.6	45	50
	6HK36501825	41.6	50.3	55.1	55	60
	6HK46502025 ³	46.2	55.1	60.4	60	70
60D	6HK36501025	23.1	30.1	32.8	35	35
	6HK36501525	34.6	42.6	46.6	45	50
	6HK36501825	41.6	50.3	55.1	55	60
	6HK46502025 ³	46.2	55.1	60.4	60	70
	6HK46502525 ³	57.7	67.7	74.2	70	80

1. Asterisk (*) denotes the 20kW and 25kW heater models (6HK46502025 and 6HK46502525) come with service disconnects standard. Single source power MCA and MOP requirements are given here only for reference if used with field installed single point power modification (S1-32436041000).
2. MOP = Maximum Overcurrent Protection device; must be HACR type circuit breaker or time delay fuse. The 1st circuit includes blower motor amps. Refer to the latest edition of the National Electric Code or in Canada the Canadian electrical Code and local codes to determine correct wire sizing.
3. The 20kW and 25kW heater models (6HK46502025 and 6HK46502525) come with circuit breakers standard. Single source power MCA and MOP requirements are given here only for reference if used with field installed single point power modification.

ELECTRICAL DATA FOR MULTI-SOURCE POWER SUPPLY: 208/230-3-60

Air Handlers Models	Heater Models ¹	Total Heater Amp @ 240V	Min. Circuit Ampacity				MOP ²			
			208V		230V		208V		230V	
			Circuit				Circuit			
			1st ²	2nd	1st ²	2nd	1st ²	2nd	1st ²	2nd
36B	6HK46502025	46.2	28.3	25.0	30.9	27.6	30	25	35	30
36C	6HK46502025	46.2	27.8	25.0	30.4	27.6	30	25	35	30
37C	6HK46502025	46.2	34.0	31.3	37.3	34.6	30	25	35	30
42C	6HK46502025	46.2	28.5	25.0	31.1	27.6	30	25	35	30
48C	6HK46502025	46.2	28.6	25.0	31.3	27.6	30	25	35	30
48D	6HK46502025	46.2	28.6	25.0	31.3	27.6	30	25	35	30
	6HK46502525	57.7	34.9	31.3	38.2	34.6	35	35	40	35
60C	6HK46502025	46.2	30.1	25.0	32.8	27.6	35	25	35	30
60D	6HK46502025	46.2	30.5	25.0	33.1	27.6	35	25	35	30
	6HK46502525	57.7	36.8	31.3	40.1	34.6	40	35	45	35

1. The 20kW and 25kW heater models (6HK46502025 and 6HK46502525) come with service disconnects standard.

2. MOP = Maximum Overcurrent Protection device; must be HACR type circuit breaker or time delay fuse. The 1st circuit includes blower motor amps. Refer to the latest edition of the National Electric Code or in Canada the Canadian electrical Code and local codes to determine correct wire sizing.

AIR FLOW DATA (CFM)¹

Models	Blower Motor Speed	External Static Pressure (in. wc.)						
		0.10	0.20	0.30	0.40	0.50	0.60	0.70
208 Volt								
18B	High	723	702	666	576	523	373	317
	Medium	566	543	480	382	305	183	N/A
	Low	394	330	183	144	N/A	N/A	N/A
24B	High	990	973	953	924	885	797	713
	Medium	736	723	703	644	606	540	457
	Low	579	562	513	463	395	287	202
30B	High	1228	1192	1134	1078	1023	951	843
	Medium	1023	998	958	915	859	741	677
	Low	769	745	701	632	577	495	433
36B	High	1522	1475	1416	1349	1276	1188	1108
	Medium	1251	1217	1180	1135	1085	1042	968
	Low	965	951	936	914	886	836	742
36C	High	1539	1489	1450	1400	1283	1201	1110
	Medium	1159	1147	1096	1042	994	943	877
	Low	966	933	892	859	812	769	679
37C	High	1508	1471	1436	1382	1217	1054	1031
	Medium	1151	1138	1117	1053	923	837	758
	Low	959	939	904	829	745	698	616
42C	High	1827	1769	1707	1634	1545	1315	1236
	Medium	1444	1423	1392	1348	1204	1118	1050
	Low	1136	1140	1116	1041	982	893	842
48C	High	1686	1643	1583	1507	1441	1357	1062
	Medium	1482	1439	1392	1340	1280	1090	971
	Low	1252	1222	1186	1148	987	928	810
48D	High	1988	1931	1853	1775	1695	1606	1391
	Medium	1672	1636	1587	1522	1439	1302	1139
	Low	1376	1348	1309	1249	1138	1038	973
60C	High	1851	1813	1757	1680	1601	1513	1262
	Medium	1718	1687	1631	1562	1499	1417	1185
	Low	1560	1546	1505	1441	1383	1258	1144
60D	High	1971	1919	1844	1757	1664	1563	1190
	Medium	1812	1763	1698	1639	1561	1451	1142
	Low	1403	1394	1364	1327	1153	1079	968

Continued on next page.

AIR FLOW DATA (CFM)¹ (Continued)

Models	Blower Motor Speed	External Static Pressure (in. wc.)						
		0.10	0.20	0.30	0.40	0.50	0.60	0.70
230 Volt								
18B	High	806	780	745	687	623	508	380
	Medium	640	614	563	500	405	284	216
	Low	461	414	325	188	156	N/A	N/A
24B	High	1142	1114	1078	1051	988	931	778
	Medium	854	840	826	800	738	688	605
	Low	684	663	633	578	510	445	322
30B	High	1261	1231	1174	1116	1051	977	891
	Medium	1117	1091	1048	984	934	863	699
	Low	864	846	795	754	663	575	488
36B	High	1601	1552	1485	1414	1337	1258	1178
	Medium	1385	1352	1302	1252	1193	1106	1057
	Low	1117	1103	1079	1044	1001	945	889
36C	High	1671	1636	1581	1513	1439	1330	1210
	Medium	1326	1310	1280	1238	1162	1081	994
	Low	1125	1102	1059	1014	950	894	827
37C	High	1681	1630	1572	1493	1427	1175	1031
	Medium	1308	1284	1250	1213	1022	951	859
	Low	1109	1096	1063	964	856	807	723
42C	High	1924	1861	1778	1707	1618	1442	1271
	Medium	1629	1585	1541	1470	1403	1226	1073
	Low	1323	1295	1271	1232	1111	1045	954
48C	High	1775	1727	1668	1596	1513	1431	1190
	Medium	1591	1551	1500	1447	1380	1312	1059
	Low	1392	1363	1317	1267	1206	1025	924
48D	High	2150	2069	1988	1894	1812	1690	1481
	Medium	1878	1812	1752	1677	1604	1497	1258
	Low	1583	1543	1493	1437	1332	1164	1075
60C	High	1931	1889	1808	1739	1655	1566	1472
	Medium	1845	1798	1731	1659	1581	1498	1249
	Low	1726	1692	1640	1578	1503	1416	1174
60D	High	2060	2006	1922	1829	1717	1613	1224
	Medium	1949	1900	1817	1735	1640	1547	1176
	Low	1600	1563	1527	1476	1400	1132	1022

1. Air handler units have been tested to UL 1995 / CSA 22.2 No. 236 standards up to 0.50" wc. external static pressure.

Dry coil conditions only, tested without filters.

For optimal performance, external static pressures of 0.2" to 0.5" are recommended. Heating applications tested at 0.50" w.c. esp.

kW & MBH CONVERSIONS - FOR TOTAL POWER INPUT REQUIREMENT

For a power distribution voltage that is different than the provided nominal voltage, multiply the kW and MBH data from the table by the conversion factor in the following table.

DISTRIBUTION POWER	NOMINAL VOLTAGE	CONVERSION FACTOR
208V	240V	0.75
220V	240V	0.84
230V	240V	0.92

APPLICATION FACTORS - RATED CFM VS. ACTUAL CFM

% Of Rated Airflow (CFM)	80%	90%	100%	110%	120%
Capacity Factor	0.96	0.98	1.00	1.02	1.03

BLOWER SPEED CONNECTIONS

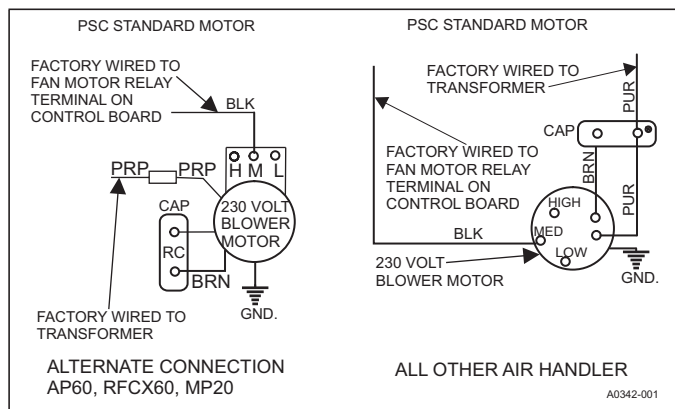

NOTICE

Filter frames are orientation specific. The block-off box provided with the kit is to be inserted after the air filter has been installed.

For upflow platform return applications, cut the hole in the return air platform the same size as the filter frame opening (dimensions for E x D in Table 1). DO NOT cut an oversized hole.

NOTICE

When attaching return air duct system to filter frame, mounting hardware should not have sharp extruding points exposed.

ACCESSORIES

Refer to Price Manual for specific model numbers where not shown.

TXV Kits - Air handlers are shipped with "Flex-coils" without a factory installed metering device. For added flexibility, an R-22 or R-410A TXV or orifice can be field installed to meet your refrigerant choice. All kits are chatteff style and require no brazing to install.

Electric Heaters - 6HK models shown under electrical data include sequential operation and temperature dual limit switches for safe, efficient operation. Service disconnects are provided where shown.

SINGLE SOURCE POWER ACCESSORIES (SINGLE PHASE)	
S1-02435670000	For heat kits with 2 service disconnects.
S1-02435671000	For heat kits with 3 service disconnects.
SINGLE SOURCE POWER ACCESSORY (THREE PHASE)	
S1-32436041000	Contains a terminal block and wiring to connect service disconnects together.

Combustible Floor Base Accessory - If an electric heat accessory which is rated for greater than zero clearance to combustible surfaces is installed in these air handlers in the downflow operating positions on a combustible floor, one of the following combustible floor base accessory models is required: S1-1FB1917, S1-1FB1921, S1-1FB1924.

Breaker Moisture Seal Accessory - A clear circuit breaker moisture barrier seals the breakers from humidity and dust. The flexibility of the clear cover allows circuit breakers to be turned ON or OFF without removing the cover. The cover firmly attaches to the access panel around the circuit breakers with the use of double backed adhesive tape. To ensure that moisture or dust does not contaminate circuit breakers, an S1-02435672000, Circuit Breaker, Cover Seal may be ordered.

Thermostat - Compatible thermostat controls are available through accessory sourcing. For optimum performance, these outdoor units are fully compatible with our residential touch screen thermostat with proprietary (patent-pending) hexagon interface. For more information, see the thermostat section of the Product Equipment Catalog.

POWER WIRING - LINE CONNECTIONS

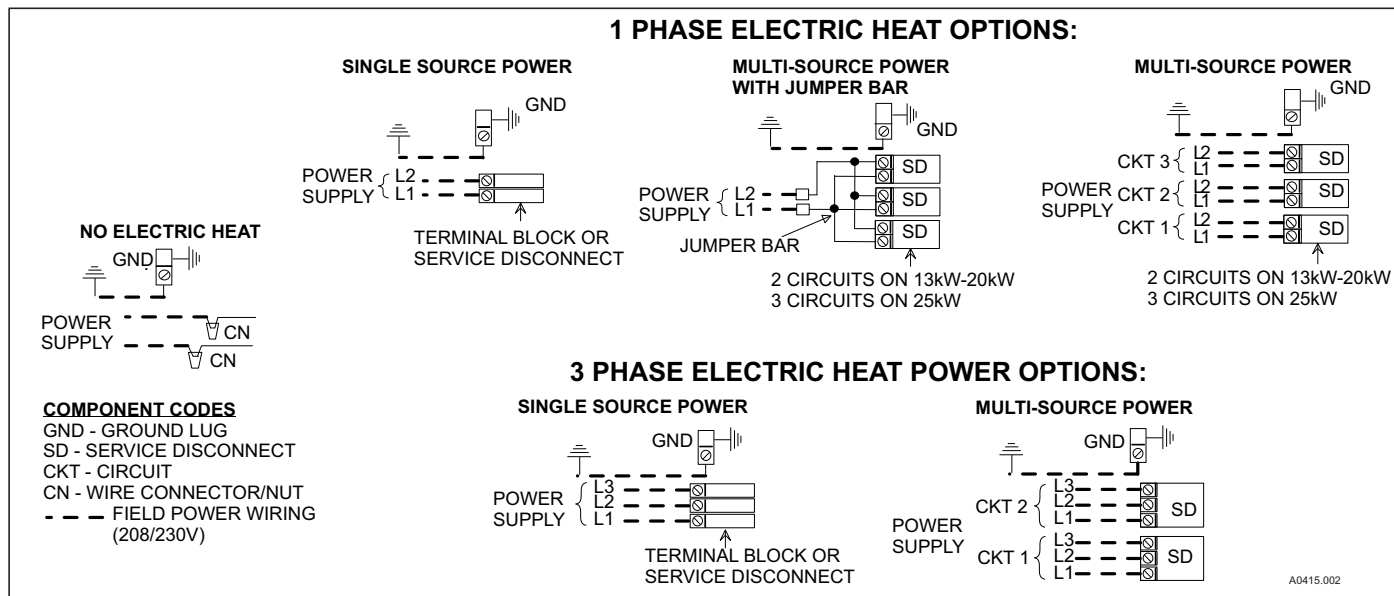

TYPICAL THERMOSTAT CONNECTION

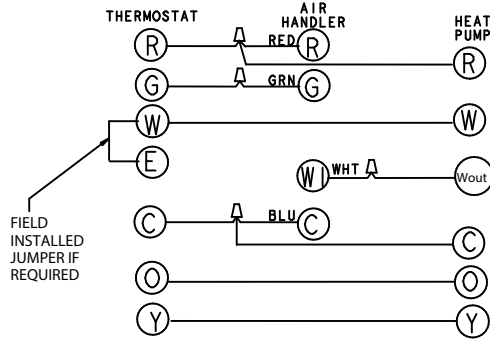
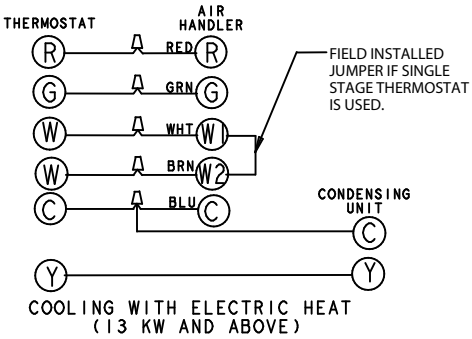
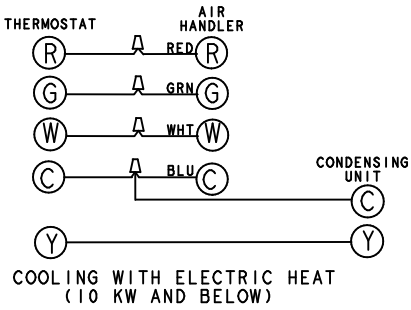
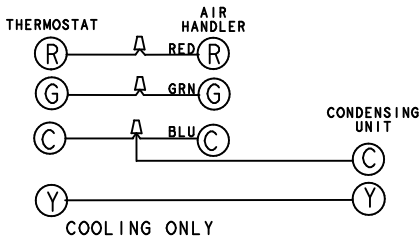

SINGLE STAGE HEAT PUMP AND ELECTRIC HEAT (10 KW AND BELOW)

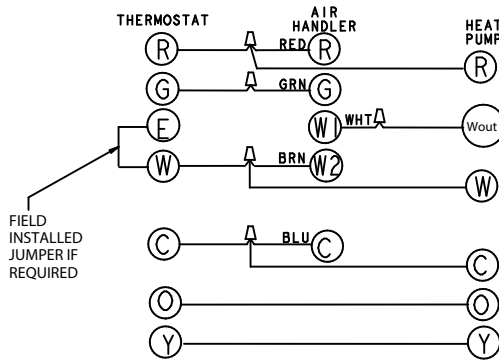

SINGLE STAGE HEAT PUMP AND ELECTRIC HEAT (13 KW AND ABOVE)

A0370-003

COMBUSTIBLE FLOOR BASE ACCESSORY

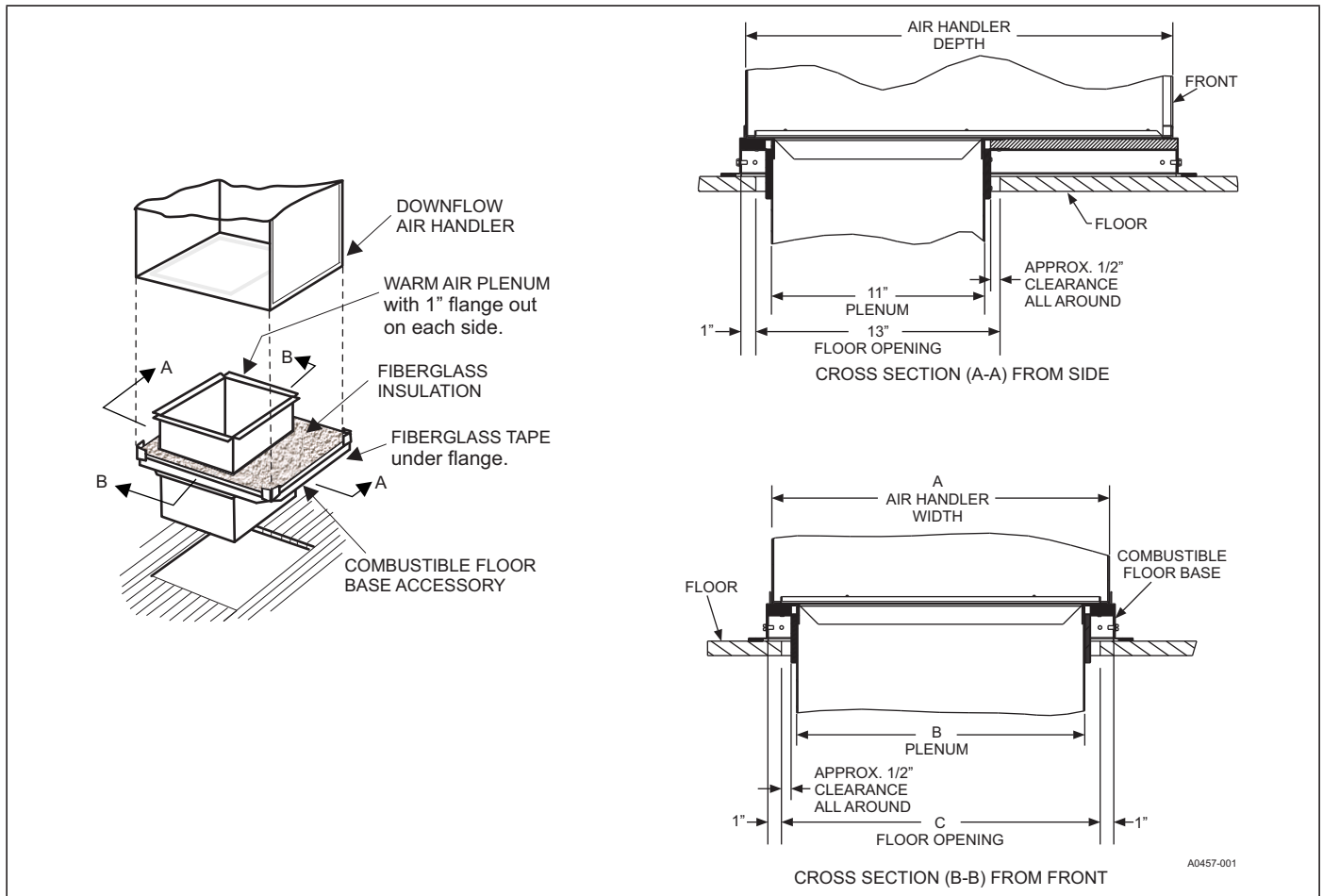

Floor Base Models	Used with	Dimensions		
		A	B	C
1FB1917	18B, 24B, 30B, 36B	17.5	14.0	16.0
1FB1921	36C, 37C, 42C, 48C, 60C	21.0	17.5	19.5
1FB1924	48D, 60D	24.5	21.0	23.0

LIMITATIONS

These units must be wired and installed in accordance with all national and local safety codes.

Voltage limits are as follows:

Air Handler Voltage	¹ Normal Operating Voltage Range
208/230-1-60	187-253

1. Rated in accordance with ARI Standard 110, utilization range "A".

Airflow must be within the minimum and maximum limits approved for electric heat, evaporator coils and outdoor units.

TYPICAL APPLICATIONS

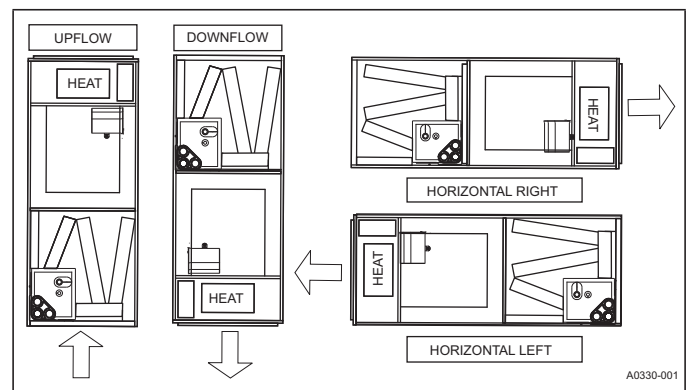

NOTES