

50TCQ
Packaged Heat Pump
3 to 12.5 Nominal Tons

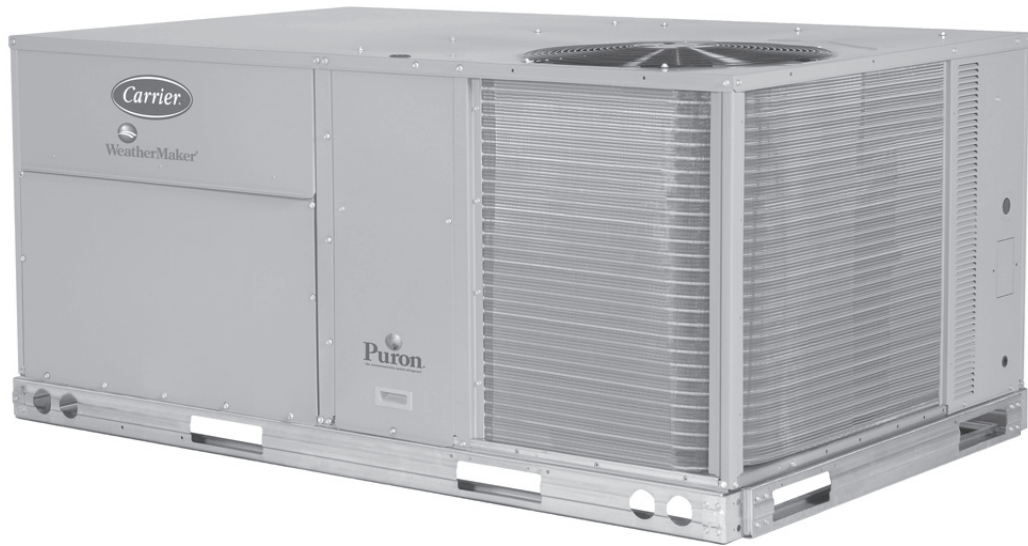

Product Data



C08613



TABLE OF CONTENTS

	PAGE		PAGE
FEATURES AND BENEFITS	3	COOLING TABLES	51
MODEL NUMBER NOMENCLATURE	4	STATIC PRESSURE TABLES	63
FACTORY OPTIONS & ACCESSORIES	5	FAN PERFORMANCE	66
AHRI CAPACITY RATING	8	ELECTRICAL INFORMATION	78
SOUND PERFORMANCE	9	MCA / MOCP	83
PHYSICAL DATA	10	TYPICAL WIRING DIAGRAMS	114
WEIGHTS & DIMENSIONS	32	SEQUENCE OF OPERATION	116
APPLICATION DATA	48	GUIDE SPECIFICATIONS	119

50TCQ



Turn to the Experts™

Your Carrier Packaged Heat Pump rooftop unit (RTU) was designed by customers for customers. With no-strip screw collars, handled access panels, and more we've made your unit easy to install, easy to maintain and easy to use.

Easy to install:

All WeatherMaker™ units are field-convertible to horizontal air flow which makes it easy to adjust to unexpected job site complications. Lighter units make easy replacement. Carrier 3 - 12.5 ton 50TCQ rooftops fit on existing Carrier curbs dating back to 1989. Also, our large control box gives you room to work and room to mount Carrier accessory controls.

Easy to maintain:

Easy access handles by Carrier provide quick and easy access to all normally serviced components. Our "no-strip" screw system has superior holding power and guides screws into position while preventing the screw from stripping the unit's metal. Take accurate pressure readings by reading condenser pressure with panels on. Simply remove the black, composite plug, route your gauge line(s) through the hole, and connect them to the refrigeration service valve(s). Now, you can take refrigeration system pressure readings without affecting the condenser airflow.

Easy to use:

The newly designed, central terminal board by Carrier puts all your connections and troubleshooting points in one convenient place, standard. Most low voltage connections are made to the same board and make it easy to find what you're looking for and easy to access it. Carrier rooftops have high and low pressure switches, a filter drier, and 2-in. (51mm) filters standard.



FEATURES AND BENEFITS

- SEER up to 13.4, EER up to 11.2.
- IEER up to 12.2 with single speed indoor fan motor and up to 12.5 with 2-speed/VFD indoor fan motor.
- Up to 28% lighter than similar industry units. Lighter rooftops make easier replacement jobs.
- 3 - 12.5 ton units fit on existing Carrier rooftop curbs making the utility connections the same. This saves time and money on replacement jobs.
- Standardized components and layout. Standardized components and controls make service and stocking parts easier.
- Scroll compressors on all units. This makes service, stocking parts, replacement, and trouble-shooting easier.
- Crankcase heater on all models (except 04 size) provides added protection in all applications.
- Precision-sized suction line accumulator provides high reliability by preventing liquid from entering the compressor during low ambient conditions and reverse cycle switch over.
- Field convertible from vertical to horizontal airflow configuration on all models. No special kit required on 04-12 models. Supply duct kit required for 14 model only.
- 4-way reversing valve rapidly changes the flow of refrigerant to quickly changeover from cooling to heating and heating to cooling.
- Easy-adjust, belt drive motor available on all sizes. There's no need for field-supplied drives or motors.
- 3-5 ton models come standard with Direct Drive X13, 5 speed/torque motor to provide exact performance in many applications. Belt drive motor optional.
- Provisions for bottom or side condensate drain.
- Capable of thru-the-base or thru-the-curb electrical routing.
- Dependable time/temperature defrost logic provides a defrost cycle, if needed, every 30, 60, 90 or 120 minutes and is adjustable.
- Single-point electrical connection.
- Sloped, composite drain pan sheds water; and won't rust.
- Standardized controls and control box layout. Standardized components and controls make stocking parts and service easier.
- Clean, large, easy to use control box.
- Standard coils are copper round tube, aluminum plate fin with optional coil coatings and copper fin design.
- Color-coded wiring.
- Large, laminated wiring and power wiring drawings which are affixed to unit make troubleshooting easy.
- Single, central terminal board for test and wiring connections.
- Fast-access, handled, panels for easy access to the blower and blower motor, control box, and compressors.
- "No-strip" screw system guides screws into the panel and captures them tightly without stripping the screw, the panel, or the unit.
- Exclusive, newly-designed indoor refrigerant header for easier maintenance and replacement.
- Mechanical cooling (115°F to 25°F or 46°C to -4°C) on Electro-Mechanical (E/M) and Direct Digital Controller (DDC) (PremierLink™ or RTU Open controller).
- 2-in. (51mm) disposable filters on all units.
- High capacity refrigerant filter drier on each circuit.
- High pressure switch, loss of charge switch and freeze protection adds greater unit reliability.
- Optional Staged Air Volume (SAV) system utilizes a Variable Frequency Drive (VFD) to automatically adjust the indoor fan motor speed between cooling stages. Available on 2-stage cooling models 08-14 with electromechanical controls or RTU Open.

MODEL NUMBER NOMENCLATURE

Position:	1	2	3	4	5	6	7	8	9	10	11	12	13	14	15	16	17	18
Example:	5	0	T	C	Q	A	0	6	A	0	A	6	-	0	B	2	A	0

Series - WeatherMaker®
50HC - Packaged Rooftop

Q = Heat Pump

Refrig. Systems Options

A = One Stage Cooling Models
D = Two Stage Cooling Models

Cooling Tons

04 - 3 ton
05 - 4 ton
06 - 5 ton
07 - 6 ton
08 - 7.5 ton
09 - 8.5 ton
12 - 10 ton
14 - 12.5 ton

Sensor Options

A = None
B = RA Smoke Detector
C = SA Smoke Detector
D = RA + SA Smoke Detector
E = CO₂
F = RA Smoke Detector and CO₂
G = SA Smoke Detector and CO₂
H = RA + SA Smoke Detector and CO₂

Indoor Fan Options

0 = Electric Drive X13 Motor (04-06)
1 = Standard Static Option - Belt Drive
2 = Medium Static Option - Belt Drive
3 = High Static Option - Belt Drive
C = High Static Option with High Efficiency Motor- Belt Drive (size 14 only)

Coil Options - Round Tube/Plate Fin Condenser Coil (Outdoor - Indoor - Hail Guard)

A = Al/Cu - Al/Cu
B = Precoat Al/Cu - Al/Cu
C = E-coat Al/Cu - Al/Cu
D = E-coat Al/Cu - E-coat Al/Cu
E = Cu/Cu - Al/Cu
F = Cu/Cu - Cu/Cu
M = Al/Cu - Al/Cu — Louvered Hail Guard
N = Precoat Al/Cu - Al/Cu — Louvered Hail Guard
P = E-coat Al/Cu - Al/Cu — Louvered Hail Guard
Q = E-coat Al/Cu - E-coat Al/Cu — Louvered Hail Guard
R = Cu/Cu - Al/Cu — Louvered Hail Guard
S = Cu/Cu - Cu/Cu — Louvered Hail Guard

Note: On single phase (-3 voltage code) models, the following are not available as a factory installed option:

- Coated Coils or Cu Fin Coils
- Louvered Hail Guards
- Economizer or 2 Position Damper
- Powered 115 Volt Convenience Outlet

Factory Assigned

0 = Standard
1 = LTL
3 = CA Seismic Compliant
4 = LTL and CA Seismic Compliant

Electrical Options

A = None
C = Non-Fused Disconnect
D = Thru-The-Base Connections
F = Non-Fused Disconnect and Thru-The-Base Connections
G = 2-Speed Indoor Fan Controller (VFD)

Service Options

0 = None
1 = Unpowered Convenience Outlet
2 = Powered Convenience Outlet
3 = Hinged Access Panels
4 = Hinged Access Panels and Unpowered Convenience Outlet
5 = Hinged Panels and Powered Convenience Outlet

Intake / Exhaust Options

A = None
B = Temperature Economizer w/ Barometric Relief
F = Enthalpy Economizer w/ Barometric Relief
K = 2-Position Damper
U = Temperature Ultra Low Leak Economizer w/ Barometric Relief
W = Enthalpy Ultra Low Leak Economizer w/ Barometric Relief

Base Unit Controls

0 = Electro-mechanical Controls can be used with W7212 EconoMi\$er IV (Non-Fault Detection and Diagnostic)
1 = PremierLink Controller
2 = RTU Open Multi-Protocol Controller
6 = Electro-mechanical w/ 2-speed fan and W7220 Economizer controller Controls. Can be used with W7220 EconoMi\$er X (with Fault Detection and Diagnostic)

Design Revision

- = Factory Design Revision

Voltage

1 = 575/3/60
3 = 208-230/1/60
5 = 208-230/3/60
6 = 460/3/60

50TCQ

FACTORY OPTIONS AND/OR ACCESSORIES

Table 1 – FACTORY-INSTALLED OPTIONS AND FIELD-INSTALLED ACCESSORIES

CATEGORY	ITEM	FACTORY INSTALLED OPTION	FIELD INSTALLED ACCESSORY
Cabinet	Thru-the-base electrical connections	X	X
	Disconnect Switch Bracket (Available 14 size only)		X
	Supply Duct Cover (Available 14 size only)		X
Coil Options	Cu/Cu indoor and/or outdoor coils ⁵	X	
	Pre-coated outdoor coils ⁵	X	
	Premium, E-coated outdoor coils ⁵	X	
Condenser Protection	Condenser coil hail guard (louvered design) ⁵	X	X
Controls	Thermostats, temperature sensors, and subbases		X
	PremierLink DDC communicating controller	X	X
	RTU Open Multi-protocol controller	X	
	Smoke detector (supply and/or return air)	X	
	Time Guard II compressor delay control circuit		X
	Phase Monitor		X
Economizers & Outdoor Air Dampers	EconoMi\$er IV (for electro-mechanical controlled – Non FDD, Standard air leak damper models) ^{5,6}	X	X
	EconoMi\$er 2 for DDC controls, complies with FDD (Standard and Ultra Low Leak air damper models) ^{5,7}	X	X
	Motorized 2 position outdoor air damper	X	X
	Manual outdoor air damper (25% and 50%)		X
	Barometric relief ¹	X	X
	Power exhaust		X
	EconoMi\$er for electro-mechanical controls, complies with FDD (Standard and Ultra Low Leak air damper controls) ^{5,6}	X	X
Economizer Sensors & IAQ Devices	Single dry bulb temperature sensors ²	X	X
	Differential dry bulb temperature sensors ²		X
	Single enthalpy sensors ²	X	X
	Differential enthalpy sensors ²		X
	CO ₂ sensor (wall, duct, or unit mounted) ²	X	X
Electric Heat	Electric Resistance Heaters		X
	Single Point Kit		X
Indoor Motor & Drive	Multiple motor and belt drive packages	X	
	Electric Drive, X13, 5-speed/torque (3–5 ton)	X	
	Staged Air Volume (SAV) system w/VFD controller (2-stage cool only with electrical mechanical and RTU Open controls)	X	
	Display Kit for SAV system with VFD		X
Low Ambient Control	Motormaster® head pressure controller ³		X
Power Options	Convenience outlet (powered) ⁵	X	
	Convenience outlet (unpowered)	X	
	Non-fused disconnect ⁴	X	
Roof Curbs	Roof curb 14-in. (356mm)		X
	Roof curb 24-in. (610mm)		X

NOTES:

1. Included with economizer.
2. Sensors for optimizing economizer.
3. See application data for assistance.
4. Available on size 04–12 units with MOCs of 80 amps or less and on size 14 units with MOCs of 100 amps or less.
5. Not available as a factory installed option on single phase (208/230/1/60) models. Use field-install accessory where available.
6. FDD – (Fault Detection and Diagnostic) capability per California Title 24 section 120.2.
7. Models with RTU Open DDC controls comply with California Title 24 Fault Detection and Diagnostic (FDD). PremierLink is not FDD.

50TCQ

FACTORY OPTIONS AND/OR ACCESSORIES (cont.)

Economizer

Economizers save money. They bring in fresh, outside air for ventilation; and provide cool, outside air to cool your building. This is the preferred method of low ambient cooling. When coupled to CO₂ sensors, Economizers can provide even more savings by coupling the ventilation air to only that amount required.

Economizers are available, installed and tested by the factory, with either enthalpy or dry bulb temperature inputs. There are also models for electromechanical as well as direct digital controllers. Additional sensors are available as accessories to optimize the economizers.

Economizers include gravity controlled, barometric relief which equalizes building pressure and ambient air pressures. This can be a cost effective solution to prevent building pressurization.

CO₂ Sensor

Improves productivity and saves money by working with the economizer to intake only the correct amount of outside air for ventilation. As occupants fill your building, the CO₂ sensor detects their presence through increasing CO₂ levels, and opens the economizer appropriately.

When the occupants leave, the CO₂ levels decrease, and the sensor appropriately closes the economizer. This intelligent control of the ventilation air, called Demand Control Ventilation (DCV) reduces the overall load on the rooftop, saving money.

Smoke Detectors

Trust the experts. Smoke detectors make your application safer and your job easier. Carrier smoke detectors immediately shut down the rooftop unit when smoke is detected. They are available, installed by the factory, for supply air, return air, or both.

Louvered Hail Guards

Sleek, louvered panels protect the condenser coil from hail damage, foreign objects, and incidental contact.

Convenience Outlet (powered or un-powered)

Lower service bills by including a convenience outlet in your specification. Carrier will install this service feature at our factory, powered. Provides a convenient, 15 amp, 115V GFCI receptacle.

Non-fused Disconnect

This OSHA-compliant, factory-installed, safety switch allows a service technician to locally secure power to the rooftop.

Power Exhaust Pressure Relief

Superior internal building pressure control. This field-installed accessory may eliminate the need for costly, external pressure control fans.

PremierLink™

This CCN controller regulates your rooftop's performance to tighter tolerances and expanded limits, as well as facilitates zoning systems and digital accessories. It also unites your Carrier HVAC equipment together on one, coherent CCN network. The PremierLink can be factory-installed, or easily field-installed.

RTU Open, Multi-protocol Controller

Connect the rooftop to an existing BAS without needing complicated translators or adapter modules using the RTU Open controller. This new controller speaks the 4 most common building automation system languages (Bacnet, Modbus, N2, and Lonworks). Use this controller when you have an existing BAS.

Time Guard II Control Circuit

This accessory protects your compressor by preventing short-cycling in the event of some other failure, prevents the compressor from restarting for 30 seconds after stopping. Not required with PremierLink®, RTU Open, or authorized commercial thermostats.

Filter or Fan Status Switches

Use these differential pressure switches to detect a filter clog or indoor fan motor failure. When used in conjunction with a compatible unit controller/thermostat, the switches will activate an alarm to warn the appropriate personnel.

Motorized 2-Position Damper

The new Carrier 2-position, motorized outdoor air damper admits up to 100% outside air. Using reliable, gear-driven technology, the 2-position damper opens to allow ventilation air and closes when the rooftop stops, stopping unwanted infiltration. Not available with Staged Air Volume (SAV).

FACTORY OPTIONS AND/OR ACCESSORIES (cont.)

Manual OA Damper

Manual outdoor air dampers are an economical way to bring in ventilation air. The dampers are available in 25% and 50% versions. Not available with Staged Air Volume (SAV).

Staged Air Volume (SAV) Indoor Fan Speed System

Carrier's Staged Air Volume (SAV) system saves energy and installation time by utilizing a Variable Frequency Drive (VFD) to automatically adjust the indoor fan motor speed in sequence with the units cooling operation. Per ASHRAE 90.1 standard section 6.4.3.10.b, during the first stage of cooling operation the VFD will adjust the fan motor to provide 2/3rd of the total cfm established for the unit. When a call for the second stage of cooling is required, the VFD will allow the total cfm for the unit established (100%). During the heating mode the VFD will allow total design cfm (100%) operation and during the ventilation mode the VFD will allow operation to 2/3rd of total cfm.

Compared to single speed indoor fan motor systems, Carrier's SAV system can save substantial energy, 25%+*, versus single speed indoor fan motor systems.

The VFD used in Carrier's SAV system has soft start capabilities to slowly ramp up the speeds, thus eliminating any high inrush air volume during initial start-up. It also has internal over current protection for the fan motor and a field installed display kit that allows adjustment and in depth diagnostics of the VFD.

This SAV system is available on models with 2-stage cooling operation with electrical mechanical or RTU Open, Multi Protocol controls. Both space sensor and conventional thermostats controls can be used to provide accurate control in any application.

The SAV system is very flexible for initial fan performance set up and adjustment. The standard factory shipped VFD is pre-programmed to automatically stage the fan speed between the first and second stage of cooling. The unit fan performance static pressure and cfm can be easily adjusted using the traditional means of pulley adjustments. The other means to adjust the unit static and cfm performance is to utilize the field installed Display Kit and adjust the frequency and voltage in the VFD to required performance requirements. In either case, once set up, the VFD will automatically adjust the speed between the cooling stage operations.

*Data based on .10 (\$/kWh) in an office application utilizing Carrier's HAP 4.6 simulation software program

Motormaster Head Pressure Controller

The Motormaster motor controller is a low ambient, head pressure controller kit that is designed to maintain the unit's condenser head pressure during periods of low ambient cooling operation. This device should be used as an alternative to economizer free cooling not when economizer usage is either not appropriate or desired. The Motormaster will either cycle the outdoor fan motors or operate them at reduced speed to maintain the unit operation, depending on the model.

Alternate Motors and Drives

Some applications need larger horsepower motors, some need more airflow, and some need both. Regardless of the case, your Carrier expert has a factory installed combination to meet your application. A wide selection of motors and pulleys (drives) are available, factory installed, to handle nearly any application.

Thru-the-Base Connections

Thru-the-base connections, available as either an accessory or as a factory option, are necessary to ensure proper connection and seal when routing wire and piping through the rooftop's basepan and curb. These couplings eliminate roof penetration and should be considered for gas lines, main power lines, as well as control power.

Disconnect Switch Bracket

Provides a pre-engineered and sized mounting bracket for applications requiring a unit mounted fused disconnect of greater than 100 amps. Bracket assures that no damage will occur to coils when mounting with screws and other fasteners.

Supply Duct Cover

This supply duct cover is required when field converting the factory standard vertical duct supply to horizontal duct supply configuration. One is required per unit. (14 size only.)

Electric Heaters

Carrier offers a full line of field-installed accessory heaters. The heaters are very easy to use and install. All are pre-engineered and certified.

Thru-the-Base Connections

Thru-the-base connections, available as either an accessory or as a factory option, are necessary to ensure proper connection and seal when routing wire and piping through the rooftop's basepan and curb. These couplings eliminate roof penetration and should be considered for gas lines, main power lines, as well as control power.

Table 2 – AHRI COOLING RATING TABLES

COOLING MODE							
50TCQ	COOLING STAGES	NOMINAL CAPACITY (TONS)	NET COOLING CAPACITY (BTUH)	TOTAL POWER (kW)	SEER	EER	IEER
A04	1	3	37,000	3.30	13.40*	11.00	N/A
A05	1	4	47,000	4.10	13.10*	11.20	N/A
A06	1	5	61,500	5.50	13.20*	11.15	N/A
A07	1	6	70,000	6.30	N/A	11.10	12.20

COOLING MODE								
50TCQ	COOLING STAGES	NOMINAL CAPACITY (TONS)	NET COOLING CAPACITY (BTUH)	TOTAL POWER (kW)	SEER	EER	IEER WITH SINGLE SPEED INDOOR MOTOR	IEER WITH 2-SPEED INDOOR MOTOR
D08	2	7.5	88,000	7.80	N/A	11.20	12.2	12.5
D09	2	8.5	99,000	8.80	N/A	11.20	12.2	12.5
D12	2	10	117,000	10.60	N/A	11.00	11.3	12.5
D14	2	12.5	142,000	13.30	N/A	10.60	10.7	12.0

NOTES:

* Electric Drive (direct drive) X13 5 speed/torque motor. SEER rating is 13.0 for belt drive.

NA Not applicable

HEATING MODE						
50TCQ	HSPF	HEATING, LOW AT 17°F (-8°C) AMBIENT		HEATING, HIGH AT 47°F (8°C) AMBIENT		
		CAPACITY (BTUH)	COP	CAPACITY (BTUH)	COP	
A04	7.70	18,200	N/A	35,600	N/A	
A05	7.70	23,600	N/A	45,500	N/A	
A06	7.70	31,200	N/A	58,000	N/A	
A07	N/A	34,800	2.25	67,000	3.30	
D08	N/A	48,000	2.25	86,000	3.40	
D09	N/A	54,500	2.25	96,000	3.30	
D12	N/A	62,300	2.25	116,000	3.40	
D14	N/A	76,000	2.05	142,000	3.20	

LEGEND

- AHRI – Air Conditioning, Heating and Refrigeration Institute
- ASHRAE – American Society of Heating, Refrigerating and Air Conditioning, Inc.
- COP – Coefficient of Performance
- EER – Energy Efficiency Ratio
- HSPF – Heating Seasonal Performance Factor
- IEER – Integrated Energy Efficiency Ratio
- SEER – Seasonal Energy Efficiency Ratio

NOTES:

1. Rated and certified under AHRI Standard 210/240 or 340/360, as appropriate.
2. Ratings are based on:
Cooling Standard: 80°F (27°C) db, 67°F (19°C) wb indoor air temp and 95°F db outdoor air temp.
IEER Standard: A measure that expresses cooling part-load EER efficiency for commercial unitary air conditioning and heat pump equipment on the basis of weighted operation at variable load capacities.
3. All 50TCQ units comply with ASHRAE 90.1 Energy Standard for minimum SEER and EER requirements.



Use of the AHRI Certified TM Mark indicates a manufacturer's participation in the program. For verification of certification for individual products, go to www.ahridirectory.org.

50TCQ

Table 3 – MINIMUM - MAXIMUM AIRFLOWS ELECTRIC HEAT

UNIT	COOLING		ELECTRIC HEATERS	
	MINIMUM	MAXIMUM	MINIMUM	MAXIMUM
50TCQ*04	900	1500	900	1500
50TCQ*05	1200	2000	1200	2000
50TCQ*06	1500	2500	1500	2500
50TCQ*07	1800	3000	1800	3000
50TCQ*08	2250 (1508)	3750	2250*	3750
50TCQ*09	2550 (1869)	4250	2550*	4250
50TCQ*12	3000 (1960)	5000	3000	5000
50TCQ*14	3750 (2680)	6250	3750	6250

() With Staged Air volume (SAV) 2-speed indoor fan motor system only. Values are minimum for VFD controller at 40Hz.

* Minimum electric heat CFM exceptions :

UNIT	UNIT VOLTAGE	HEATER kW	UNIT CONFIGURATION	REQUIRED MINIMUM CFM
50TCQ*08	575	17.0	Horizontal or Vertical	2800
50TCQ*09		34.0		2350

50TCQ

Table 4 – SOUND PERFORMANCE TABLE

50TCQ	OUTDOOR SOUND (dB)								
	A-WEIGHTED	63	125	250	500	1000	2000	4000	8000
A04	77	78.9	81.7	74.9	72.5	70.3	65.6	65.6	62.6
A05	80	90.4	84.6	77.6	77.5	74.8	70.6	68.0	64.2
A06	80	92.7	84.9	79.0	76.7	73.8	69.6	66.4	62.8
A07	78	88.0	79.5	76.2	75.8	72.5	68.6	65.7	62.4
D08	82	89.7	81.5	80.5	79.2	77.1	73.2	70.2	67.4
D09	84	90.8	85.2	81.6	79.5	78.1	74.0	70.4	66.5
D12	87	88.1	90.0	85.9	83.0	81.6	78.5	76.4	75.5
D14	83	89.3	85.2	80.3	78.0	77.0	74.4	73.7	68.9

LEGEND

dB – Decibel

NOTES:

1. Outdoor sound data is measured in accordance with AHRI standard 270.
2. Measurements are expressed in terms of sound power. Do not compare these values to sound pressure values because sound pressure accounts for specific environmental factors which do not match individual applications. Sound power values are independent of the environment and therefore more accurate.
3. A-weighted sound ratings filter out very high and very low frequencies, to better approximate the response of an "average" human ear. A-weighted measurements for Carrier units are taken in accordance with 270.

Table 5 – PHYSICAL DATA

(COOLING)

3 - 6 TONS

	50TCQA04	50TCQA05	50TCQA06	50TCQA07	
Refrigeration System					
# Circuits / # Comp. / Type	1 / 1 / Scroll	1 / 1 / Scroll	1 / 1 / Scroll	1 / 1 / Scroll	
Puron® refriger. (R-410A) charge per circuit A/B (lbs-oz)	9 – 8 / –	10 – 3 / –	12 – 13 / –	17 – 10 / –	
Metering Device	Acutrol	Acutrol	Acutrol	Acutrol	
High pressure Trip / Reset (psig)	630 / 505	630 / 505	630 / 505	630 / 505	
Loss of Charge Pressure Trip / Reset (psig)	27 / 44	27 / 44	27 / 44	27 / 44	
Compressor Capacity Staging (%)	100%	100%	100%	100%	
Evap. Coil					
Material – Tube / Fin	Cu / Al	Cu / Al	Cu / Al	Cu / Al	
Coil type	3/8-in RTPF	3/8-in RTPF	3/8-in RTPF	3/8-in RTPF	
Rows / FPI	3 / 15	3 / 15	4 / 15	4 / 15	
Total Face Area (ft ²)	5.5	5.5	7.3	7.3	
Condensate Drain Conn. Size	3/4-in	3/4-in	3/4-in	3/4-in	
Evap. Fan and Motor					
Standard Static 1 phase	Motor Qty / Drive Type	1 / Direct	1 / Direct	1 / Direct	N/A
	Max BHP	1.0	1.0	1.0	N/A
	RPM Range	600–1200	600–1200	600–1200	N/A
	Motor Frame Size	48	48	48	N/A
	Fan Qty / Type	1 / Centrifugal	1 / Centrifugal	1 / Centrifugal	N/A
	Fan Diameter x Length (in)	10 x 10	10 x 10	11 x 10	N/A
Standard Static 3 phase	Motor Qty / Drive Type	1 / Direct	1 / Direct	1 / Direct	1 / Belt
	Max BHP	1.0	1.0	1.0	1.5
	RPM Range	600–1200	600–1200	600–1200	878–1192
	Motor Frame Size	48	48	48	56
	Fan Qty / Type	1 / Centrifugal	1 / Centrifugal	1 / Centrifugal	1 / Centrifugal
	Fan Diameter x Length (in)	10 x 10	10 x 10	11 x 10	10 x 10
Medium Static 3 phase	Motor Qty / Drive Type	1 / Belt	1 / Belt	1 / Belt	1 / Belt
	Max BHP	1.5	1.5	2.0	2.9
	RPM Range	819–1251	920–1303	1066–1380	1066–1380
	Motor Frame Size	56	56	56	56
	Fan Qty / Type	1 / Centrifugal	1 / Centrifugal	1 / Centrifugal	1 / Centrifugal
	Fan Diameter x Length (in)	10 x 10	10 x 10	10 x 10	10 x 10
High Static 3 phase	Motor Qty / Drive Type	1 / Belt	1 / Belt	1 / Belt	1 / Belt
	Max BHP	2.0	2.0	2.9	2.9
	RPM Range	1035–1466	1035–1466	1208–1639	1208–1639
	Motor Frame Size	56	56	56	56
	Fan Qty / Type	1 / Centrifugal	1 / Centrifugal	1 / Centrifugal	1 / Centrifugal
	Fan Diameter x Length (in)	10 x 10	10 x 10	10 x 10	10 x 10
Cond. Coil					
Material – Tube / Fin	Cu / Al	Cu / Al	Cu / Al	Cu / Al	
Coil type	3/8-in RTPF	3/8-in RTPF	3/8-in RTPF	3/8-in RTPF	
Rows / FPI	2 / 17	2 / 17	2 / 17	2 / 17	
Total Face Area (ft ²)	10.7	12.7	15	21.3	
Cond. fan / motor					
Qty / Motor Drive Type	1 / Direct	1 / Direct	1 / Direct	1 / Direct	
Motor HP / RPM	1/8 / 825	1/4 / 1100	1/4 / 1100	1/4 / 1100	
Fan diameter (in)	22	22	22	22	
Filters					
RA Filter # / Size (in)	2 / 16 x 25 x 2	2 / 16 x 25 x 2	4 / 16 x 16 x 2	4 / 16 x 16 x 2	
OA inlet screen # / Size (in)	1 / 20 x 24 x 1	1 / 20 x 24 x 1	1 / 20 x 24 x 1	1 / 20 x 24 x 1	

50TCQ

Table 6 – 50TCQA04

ELECTRIC HEAT - ELECTRICAL DATA
SINGLE STAGE COOLING SINGLE SPEED INDOOR FAN MOTOR

NOM. V-Ph-Hz	IFM TYPE	ELECTRIC HEATER PART NUMBER CRHEATER	NOM PWR (kW)	APP PWR (kW)	SINGLE POINT KIT PART NUMBER CRSINGLE			
					WITHOUT C.O. or UNPWRD C.O.		WITH PWRD C.O.	
					WITHOUT P.E.	w/ P.E. (pwrd fr/unit)	WITHOUT P.E.	w/ P.E. (pwrd fr/unit)
208/ 230-1-60	STD DD	101A00	4.4	3.3/4.0	037A00	037A00	037A00	040A00
		102A00	6.5	4.9/6.0	040A00	040A00	040A00	040A00
		103B00	8.7	6.5/8.0	040A00	040A00	040A00	040A00
		104B00	10.5	7.9/9.6	040A00	040A00	040A00	040A00
		102A00,102A00	13.0	9.8/11.9	041A00	041A00	041A00	041A00
208/ 230-3-60	STD DD	101A00	4.4	3.3/4.0	-	-	-	-
		102A00	6.5	4.9/6.0	-	-	-	037A00
		103B00	8.7	6.5/8.0	037A00	037A00	037A00	037A00
		104B00	10.5	7.9/9.6	037A00	037A00	038A00	038A00
		105A00	16.0	12.0/14.7	038A00	038A00	038A00	038A00
	MED BD	101A00	4.4	3.3/4.0	-	-	-	-
		102A00	6.5	4.9/6.0	-	-	-	-
		103B00	8.7	6.5/8.0	-	037A00	037A00	037A00
		104B00	10.5	7.9/9.6	037A00	037A00	037A00	038A00
		105A00	16.0	12.0/14.7	038A00	038A00	038A00	038A00
	HIGH BD	101A00	4.4	3.3/4.0	-	-	-	-
		102A00	6.5	4.9/6.0	-	-	-	-
		103B00	8.7	6.5/8.0	-	037A00	037A00	037A00
		104B00	10.5	7.9/9.6	037A00	037A00	037A00	038A00
		105A00	16.0	12.0/14.7	038A00	038A00	038A00	038A00
460-3-60	STD DD	106A00	6.0	5.5	-	-	-	-
		107A00	8.8	8.1	-	-	-	-
		108A00	11.5	10.6	-	-	-	-
		109A00	14.0	12.9	-	-	-	-
	MED BD	106A00	6.0	5.5	-	-	-	-
		107A00	8.8	8.1	-	-	-	-
		108A00	11.5	10.6	-	-	-	-
		109A00	14.0	12.9	-	-	-	-
	HIGH BD	106A00	6.0	5.5	-	-	-	-
		107A00	8.8	8.1	-	-	-	-
		108A00	11.5	10.6	-	-	-	-
		109A00	14.0	12.9	-	-	-	-

50TCQ

LEGEND

- No Single Point Kit required
- APP PWR - 208 / 230V / 460V / 575V
- BD - Belt drive motor
- C.O. - Convenience outlet
- DD - Electric Drive X13 5 speed/torque motor
- FLA - Full load amps
- IFM - Indoor fan motor
- NOM PWR - 240V / 480V / 600V
- P.E. - Power exhaust
- PWRD - Powered convenience outlet
- UNPWRD - Unpowered convenience outlet

Table 7 – 50TCQA05

**ELECTRIC HEAT - ELECTRICAL DATA
SINGLE STAGE COOLING SINGLE SPEED INDOOR FAN MOTOR**

NOM. V-Ph-Hz	IFM TYPE	ELECTRIC HEATER PART NUMBER CRHEATER	NOM PWR (kW)	APP PWR (kW)	SINGLE POINT KIT PART NUMBER CRSINGLE			
					WITHOUT C.O. or UNPWRD C.O.		WITH PWRD C.O.	
					WITHOUT P.E.	w/ P.E. (pwrd fr/unit)	WITHOUT P.E.	w/ P.E. (pwrd fr/unit)
208/ 230-1-60	STD DD	101A00	4.4	3.3/4.0	037A00	040A00	040A00	040A00
		103B00	8.7	6.5/8.0	040A00	040A00	040A00	040A00
		102A00,102A00	13.0	9.8/11.9	041A00	041A00	041A00	041A00
		103B00,103B00	17.4	13.1/16.0	041A00	041A00	041A00	041A00
		104B00,104B00	21.0	15.8/19.3	041A00	041A00	041A00	041A00
208/ 230-3-60	STD DD	102A00	6.5	4.9/6.0	-	-	-	037A00
		103B00	8.7	6.5/8.0	037A00	037A00	037A00	037A00
		105A00	16.0	12.0/14.7	038A00	038A00	038A00	038A00
		104B00,104B00	21.0	15.8/19.3	039A00	039A00	039A00	039A00
	MED BD	102A00	6.5	4.9/6.0	-	-	-	-
		103B00	8.7	6.5/8.0	-	037A00	037A00	037A00
		105A00	16.0	12.0/14.7	038A00	038A00	038A00	038A00
		104B00,104B00	21.0	15.8/19.3	039A00	039A00	039A00	039A00
	HIGH BD	102A00	6.5	4.9/6.0	-	-	-	-
		103B00	8.7	6.5/8.0	-	037A00	037A00	037A00
		105A00	16.0	12.0/14.7	038A00	038A00	038A00	038A00
		104B00,104B00	21.0	15.8/19.3	039A00	039A00	039A00	039A00
460-3-60	STD DD	106A00	6.0	5.5	-	-	-	-
		108A00	11.5	10.6	-	-	-	-
		109A00	14.0	12.9	-	-	-	-
		108A00,108A00	23.0	21.1	037A00	037A00	037A00	037A00
	MED BD	106A00	6.0	5.5	-	-	-	-
		108A00	11.5	10.6	-	-	-	-
		109A00	14.0	12.9	-	-	-	-
		108A00,108A00	23.0	21.1	037A00	037A00	037A00	037A00
	HIGH BD	106A00	6.0	5.5	-	-	-	-
		108A00	11.5	10.6	-	-	-	-
		109A00	14.0	12.9	-	-	-	-
		108A00,108A00	23.0	21.1	037A00	037A00	037A00	037A00

50TCQ

LEGEND

- No Single Point Kit required
- APP PWR - 208 / 230V / 460V / 575V
- BD - Belt drive motor
- C.O. - Convenience outlet
- DD - Electric Drive X13 5 speed/torque motor
- FLA - Full load amps
- IFM - Indoor fan motor
- NOM PWR - 240V / 480V / 600V
- P.E. - Power exhaust
- PWRD - Powered convenience outlet
- UNPWRD - Unpowered convenience outlet

Table 8 – 50TCQA06

**ELECTRIC HEAT - ELECTRICAL DATA
SINGLE STAGE COOLING SINGLE SPEED INDOOR FAN MOTOR**

NOM. V-Ph-Hz	IFM TYPE	ELECTRIC HEATER PART NUMBER CRHEATER	NOM PWR (kW)	APP PWR (kW)	SINGLE POINT KIT PART NUMBER CRSINGLE			
					WITHOUT C.O. or UNPWRD C.O.		WITH PWRD C.O.	
					WITHOUT P.E.	w/ P.E. (pwrd fr/ unit)	WITHOUT P.E.	w/ P.E. (pwrd fr/ unit)
208/ 230-1-60	STD DD	102A00	6.5	4.9/6.0	040A00	040A00	040A00	040A00
		103B00	8.7	6.5/8.0	040A00	040A00	040A00	040A00
		102A00,102A00	13.0	9.8/11.9	041A00	041A00	041A00	041A00
		103B00,103B00	17.4	13.1/16.0	041A00	041A00	041A00	041A00
		104B00,104B00	21.0	15.8/19.3	041A00	041A00	041A00	041A00
208/ 230-3-60	STD DD	102A00	6.5	4.9/6.0	-	-	037A00	037A00
		104B00	10.5	7.9/9.6	038A00	038A00	038A00	038A00
		105A00	16.0	12.0/14.7	038A00	038A00	038A00	038A00
		104B00,104B00	21.0	15.8/19.3	039A00	039A00	039A00	039A00
		104B00,105A00	26.5	19.9/24.3	039A00	039A00	039A00	039A00
	MED BD	102A00	6.5	4.9/6.0	-	-	-	037A00
		104B00	10.5	7.9/9.6	037A00	037A00	038A00	038A00
		105A00	16.0	12.0/14.7	038A00	038A00	038A00	038A00
		104B00,104B00	21.0	15.8/19.3	039A00	039A00	039A00	039A00
		104B00,105A00	26.5	19.9/24.3	039A00	039A00	039A00	039A00
	HIGH BD	102A00	6.5	4.9/6.0	-	-	037A00	037A00
		104B00	10.5	7.9/9.6	038A00	038A00	038A00	038A00
		105A00	16.0	12.0/14.7	038A00	038A00	038A00	038A00
		104B00,104B00	21.0	15.8/19.3	039A00	039A00	039A00	039A00
		104B00,105A00	26.5	19.9/24.3	039A00	039A00	039A00	039A00
460-3-60	STD DD	106A00	6.0	5.5	-	-	-	-
		108A00	11.5	10.6	-	-	-	-
		109A00	14.0	12.9	-	-	-	-
		108A00,108A00	23.0	21.1	037A00	037A00	037A00	037A00
		108A00,109A00	25.5	23.4	037A00	037A00	037A00	037A00
	MED BD	106A00	6.0	5.5	-	-	-	-
		108A00	11.5	10.6	-	-	-	-
		109A00	14.0	12.9	-	-	-	-
		108A00,108A00	23.0	21.1	037A00	037A00	037A00	037A00
		108A00,109A00	25.5	23.4	037A00	037A00	037A00	037A00
	HIGH BD	106A00	6.0	5.5	-	-	-	-
		108A00	11.5	10.6	-	-	-	-
		109A00	14.0	12.9	-	-	-	-
		108A00,108A00	23.0	21.1	037A00	037A00	037A00	037A00
		108A00,109A00	25.5	23.4	037A00	037A00	037A00	037A00

50TCQ

LEGEND

- No Single Point Kit required
- APP PWR - 208 / 230V / 460V / 575V
- BD - Belt drive motor
- C.O. - Convenience outlet
- DD - Electric Drive X13 5 speed/torque motor
- FLA - Full load amps
- IFM - Indoor fan motor
- NOM PWR - 240V / 480V / 600V
- P.E. - Power exhaust
- PWRD - Powered convenience outlet
- UNPWRD - Unpowered convenience outlet

Table 9 – 50TCQA07

ELECTRIC HEAT - ELECTRICAL DATA
SINGLE STAGE COOLING SINGLE SPEED INDOOR FAN MOTOR

NOM. V-Ph-Hz	IFM TYPE	ELECTRIC HEATER PART NUMBER CRHEATER	NOM PWR (kW)	APP PWR (kW)	SINGLE POINT KIT PART NUMBER CRSINGLE			
					WITHOUT C.O. or UNPWRD C.O.		WITH PWRD C.O.	
					WITHOUT P.E.	w/ P.E. (pwrd fr/unit)	WITHOUT P.E.	w/ P.E. (pwrd fr/unit)
208/ 230-3-60	STD	102A00	6.5	4.9/6.0	-	037A00	037A00	037A00
		104B00	10.5	7.9/9.6	038A00	038A00	038A00	038A00
		105A00	16.0	12.0/14.7	038A00	038A00	038A00	038A00
		104B00,104B00	21.0	15.8/19.3	039A00	039A00	039A00	039A00
		104B00,105A00	26.5	19.9/24.3	039A00	039A00	039A00	039A00
	MED	102A00	6.5	4.9/6.0	037A00	037A00	037A00	037A00
		104B00	10.5	7.9/9.6	038A00	038A00	038A00	038A00
		105A00	16.0	12.0/14.7	038A00	038A00	038A00	038A00
		104B00,104B00	21.0	15.8/19.3	039A00	039A00	039A00	039A00
		104B00,105A00	26.5	19.9/24.3	039A00	039A00	039A00	039A00
	HIGH	102A00	6.5	4.9/6.0	037A00	037A00	037A00	037A00
		104B00	10.5	7.9/9.6	038A00	038A00	038A00	038A00
105A00		16.0	12.0/14.7	038A00	038A00	038A00	038A00	
104B00,104B00		21.0	15.8/19.3	039A00	039A00	039A00	039A00	
104B00,105A00		26.5	19.9/24.3	039A00	039A00	039A00	039A00	
460-3-60	STD	106A00	6.0	5.5	-	-	-	-
		108A00	11.5	10.6	-	-	-	-
		109A00	14.0	12.9	-	-	-	-
		108A00,108A00	23.0	21.1	037A00	037A00	037A00	037A00
		108A00,109A00	25.5	23.4	037A00	037A00	037A00	037A00
	MED	106A00	6.0	5.5	-	-	-	-
		108A00	11.5	10.6	-	-	-	-
		109A00	14.0	12.9	-	-	-	-
		108A00,108A00	23.0	21.1	037A00	037A00	037A00	037A00
		108A00,109A00	25.5	23.4	037A00	037A00	037A00	037A00
	HIGH	106A00	6.0	5.5	-	-	-	-
		108A00	11.5	10.6	-	-	-	-
109A00		14.0	12.9	-	-	-	-	
108A00,108A00		23.0	21.1	037A00	037A00	037A00	037A00	
108A00,109A00		25.5	23.4	037A00	037A00	037A00	037A00	

LEGEND

- No Single Point Kit required
- APP PWR - 208 / 230V / 460V / 575V
- C.O. - Convenience outlet
- FLA - Full load amps
- IFM - Indoor fan motor
- NOM PWR - 240V / 480V / 600V
- P.E. - Power exhaust
- PWRD - Powered convenience outlet
- UNPWRD - Unpowered convenience outlet

50TCQ

Table 10 – PHYSICAL DATA

(COOLING)

7.5 - 12.5 TONS

		50TCQD08	50TCQD09	50TCQD12	50TCQD14
Refrigeration System					
	# Circuits / # Comp. / Type	2 / 2 / Scroll	2 / 2 / Scroll	2 / 2 / Scroll	2 / 2 / Scroll
	Puron® refrig. (R-410A) charge per circuit A/B (lbs-oz)	10 - 3 / 10 - 3	11 - 2 / 11 - 2	12 - 2 / 11 - 2	14 - 8 / 13 - 8
	Metering Device	Acutrol	Acutrol	Acutrol	Acutrol
	High pressure Trip / Reset (psig)	630 / 505	630 / 505	630 / 505	630 / 505
	Loss of Charge Pressure Trip / Reset (psig)	27 / 44	27 / 44	27 / 44	27 / 44
	Compressor Capacity Staging (%)	50% / 100%	50% / 100%	50% / 100%	50% / 100%
Evap. Coil					
	Material – Tube / Fin	Cu / Al	Cu / Al	Cu / Al	Cu / Al
	Coil type	3/8-in RTPF	3/8-in RTPF	3/8-in RTPF	3/8-in RTPF
	Rows / FPI	3 / 15	4 / 15	4 / 15	3 / 15
	Total Face Area (ft ²)	11.1	11.1	11.1	17.5
	Condensate Drain Conn. Size	3/4"	3/4"	3/4"	3/4"
Evap. Fan and Motor					
Standard Static 3 phase	Motor Qty / Drive Type	1 / Belt	1 / Belt	1 / Belt	1 / Belt
	Max BHP	1.2	1.2	1.2	2.9
	RPM Range	460-652	460-652	460-652	507-676
	Motor Frame Size	56	56	56	56
	Fan Qty / Type	1 / Centrifugal	1 / Centrifugal	1 / Centrifugal	1 / Centrifugal
	Fan Diameter x Length (in)	15 x 15	15 x 15	15 x 15	18 x 18
Medium Static 3 phase	Motor Qty / Drive Type	1 / Belt	1 / Belt	1 / Belt	1 / Belt
	Max BHP	2.9	2.9	2.9	2.9
	RPM Range	591-838	591-838	591-838	634-833
	Motor Frame Size	56	56	56	56
	Fan Qty / Type	1 / Centrifugal	1 / Centrifugal	1 / Centrifugal	1 / Centrifugal
	Fan Diameter x Length (in)	15 x 15	15 x 15	15 x 15	18 x 18
High Static 3 phase	Motor Qty / Drive Type	1 / Belt	1 / Belt	1 / Belt	1 / Belt
	Max BHP	2.9	2.9	2.9	6.1
	RPM Range	838-1084	838-1084	838-1084	792-971
	Motor Frame Size	56	56	56	S184T
	Fan Qty / Type	1 / Centrifugal	1 / Centrifugal	1 / Centrifugal	1 / Centrifugal
	Fan Diameter x Length (in)	15 x 15	15 x 15	15 x 15	18 x 18
Cond. Coil					
	Material – Tube / Fin	Cu / Al	Cu / Al	Cu / Al	Cu / Al
	Coil type	3/8-in RTPF	3/8-in RTPF	3/8-in RTPF	3/8-in RTPF
	Rows / FPI	2 / 17	2 / 17	3 / 17	2 / 17
	Total Face Area (ft ²)	25.1	25.1	25.1	36.1
Cond. fan / motor					
	Qty / Motor Drive Type	2 / Direct	2 / Direct	1 / Direct	3 / Direct
	Motor HP / RPM	1/4 / 1100	1/4 / 1100	1 / 1175	1/4 / 1100
	Fan diameter (in)	22	22	30	22
Filters					
	RA Filter # / Size (in)	4 / 20 x 20 x 2	4 / 20 x 20 x 2	4 / 20 x 20 x 2	6 / 18 x 24 x 2
	OA inlet screen # / Size (in)	1 / 20 x 24 x 1	1 / 20 x 24 x 1	1 / 20 x 24 x 1	2 / 24 x 27 x 1 (Vertical) 1 / 30 x 39 x 1 (Horizontal)

50TCQ

Table 11 – 50TCQA04

**ELECTRIC HEAT - ELECTRICAL DATA
SINGLE STAGE COOLING SINGLE SPEED INDOOR FAN
AND FACTORY INSTALLED NON-FUSED DISCONNECT SWITCH**

NOM. V-Ph-Hz	IFM TYPE	ELECTRIC HEATER PART NUMBER CRHEATER	NOM PWR (kW)	APP PWR (kW)	SINGLE POINT KIT PART NUMBER CRSINGLE *****			
					WITHOUT C.O. Or UNPWRD C.O.		WITH PWRD C.O.	
					WITHOUT P.E.	w/ P.E. (pwrd fr/unit)	WITHOUT P.E.	w/ P.E. (pwrd fr/unit)
208/ 230-1-60	STD DD	101A00	4.4	3.3/4.0	037A00	037A00	-	-
		102A00	6.5	4.9/6.0	040A00	040A00	-	-
		103B00	8.7	6.5/8.0	040A00	040A00	-	-
		104B00	10.5	7.9/9.6	040A00	040A00	-	-
		102A00,102A00	13.0	9.8/11.9	041A00	041A00	-	-
208/ 230-3-60	STD DD	101A00	4.4	3.3/4.0	037A00	037A00	037A00	037A00
		102A00	6.5	4.9/6.0	037A00	037A00	037A00	037A00
		103B00	8.7	6.5/8.0	037A00	037A00	037A00	037A00
		104B00	10.5	7.9/9.6	037A00	037A00	038A00	038A00
		105A00	16.0	12.0/14.7	038A00	038A00	038A00	038A00
	MED BD	101A00	4.4	3.3/4.0	037A00	037A00	037A00	037A00
		102A00	6.5	4.9/6.0	037A00	037A00	037A00	037A00
		103B00	8.7	6.5/8.0	037A00	037A00	037A00	037A00
		104B00	10.5	7.9/9.6	037A00	037A00	037A00	038A00
		105A00	16.0	12.0/14.7	038A00	038A00	038A00	038A00
	HIGH BD	101A00	4.4	3.3/4.0	037A00	037A00	037A00	037A00
		102A00	6.5	4.9/6.0	037A00	037A00	037A00	037A00
		103B00	8.7	6.5/8.0	037A00	037A00	037A00	037A00
		104B00	10.5	7.9/9.6	037A00	037A00	037A00	038A00
		105A00	16.0	12.0/14.7	038A00	038A00	038A00	038A00
460-3-60	STD BD	106A00	6.0	5.5	-	-	-	-
		107A00	8.8	8.1	-	-	-	-
		108A00	11.5	10.6	-	-	-	-
		109A00	14.0	12.9	-	-	-	-
	MED BD	106A00	6.0	5.5	-	-	-	-
		107A00	8.8	8.1	-	-	-	-
		108A00	11.5	10.6	-	-	-	-
		109A00	14.0	12.9	-	-	-	-
	HIGH DD	106A00	6.0	5.5	-	-	-	-
		107A00	8.8	8.1	-	-	-	-
		108A00	11.5	10.6	-	-	-	-
		109A00	14.0	12.9	-	-	-	-

LEGEND

- No Single Point Kit required
- APP PWR - 208 / 230V / 460V / 575V
- BD - Belt drive motor
- C.O. - Convenience outlet
- DD - Drive X13 5 speed/torque motor
- FLA - Full load amps
- IFM - Indoor fan motor
- NOM PWR - 240V / 480V / 600V
- P.E. - Power exhaust
- PWRD - Powered convenience outlet
- UNPWRD - Unpowered convenience outlet

50TCQ

Table 12 – 50TCQA05

**ELECTRIC HEAT - ELECTRICAL DATA
SINGLE STAGE COOLING SINGLE SPEED INDOOR FAN
AND FACTORY INSTALLED NON-FUSED DISCONNECT SWITCH**

NOM. V-Ph-Hz	IFM TYPE	ELECTRIC HEATER PART NUMBER CRHEATER	NOM PWR (kW)	APP PWR (kW)	SINGLE POINT KIT PART NUMBER CRSINGLE *****			
					WITHOUT C.O. or UNPWRD C.O.		WITH PWRD C.O.	
					WITHOUT P.E.	w/ P.E. (pwrd fr/unit)	WITHOUT P.E.	w/ P.E. (pwrd fr/unit)
208/ 230-1-60	STD DD	101A00	4.4	3.3/4.0	037A00	040A00	-	-
		103B00	8.7	6.5/8.0	040A00	040A00	-	-
		102A00,102A00	13.0	9.8/11.9	041A00	041A00	-	-
		103B00,103B00	17.4	13.1/16.0	041A00	041A00	-	-
		104B00,104B00	21.0	15.8/19.3	041A00	041A00	-	-
208/ 230-3-60	STD DD	102A00	6.5	4.9/6.0	037A00	037A00	037A00	037A00
		103B00	8.7	6.5/8.0	037A00	037A00	037A00	037A00
		105A00	16.0	12.0/14.7	038A00	038A00	038A00	038A00
		104B00,104B00	21.0	15.8/19.3	039A00	039A00	039A00	039A00
	MED BD	102A00	6.5	4.9/6.0	037A00	037A00	037A00	037A00
		103B00	8.7	6.5/8.0	037A00	037A00	037A00	037A00
		105A00	16.0	12.0/14.7	038A00	038A00	038A00	038A00
		104B00,104B00	21.0	15.8/19.3	039A00	039A00	039A00	039A00
	HIGH BD	102A00	6.5	4.9/6.0	037A00	-	-	-
		103B00	8.7	6.5/8.0	037A00	037A00	037A00	037A00
		105A00	16.0	12.0/14.7	038A00	038A00	038A00	038A00
		104B00,104B00	21.0	15.8/19.3	039A00	039A00	039A00	039A00
460-3-60	STD DD	106A00	6.0	5.5	-	-	-	-
		108A00	11.5	10.6	-	-	-	-
		109A00	14.0	12.9	-	-	-	-
		108A00,108A00	23.0	21.1	037A00	037A00	037A00	037A00
	MED BD	106A00	6.0	5.5	-	-	-	-
		108A00	11.5	10.6	-	-	-	-
		109A00	14.0	12.9	-	-	-	-
		108A00,108A00	23.0	21.1	037A00	037A00	037A00	037A00
	HIGH BD	106A00	6.0	5.5	-	-	-	-
		108A00	11.5	10.6	-	-	-	-
		109A00	14.0	12.9	-	-	-	-
		108A00,108A00	23.0	21.1	037A00	037A00	037A00	037A00

50TCQ

LEGEND

- No Single Point Kit required
- APP PWR - 208 / 230V / 460V / 575V
- BD - Belt drive motor
- C.O. - Convenience outlet
- DD - Drive X13 5 speed/torque motor
- FLA - Full load amps
- IFM - Indoor fan motor
- NOM PWR - 240V / 480V / 600V
- P.E. - Power exhaust
- PWRD - Powered convenience outlet
- UNPWRD - Unpowered convenience outlet

Table 13 – 50TCQA06

**ELECTRIC HEAT - ELECTRICAL DATA
SINGLE STAGE COOLING SINGLE SPEED INDOOR FAN
AND FACTORY INSTALLED NON-FUSED DISCONNECT SWITCH**

NOM. V-Ph-Hz	IFM TYPE	ELECTRIC HEATER PART NUMBER CRHEATER	NOM PWR (kW)	APP PWR (kW)	SINGLE POINT KIT PART NUMBER CRSINGLE *****			
					WITHOUT C.O. or UNPWRD C.O.		WITH PWRD C.O.	
					WITHOUT P.E.	w/ P.E. (pwrd fr/ unit)	WITHOUT P.E.	w/ P.E. (pwrd fr/ unit)
208/ 230-1-60	STD DD	102A00	6.5	4.9/6.0	040A00	040A00	-	-
		103B00	8.7	6.5/8.0	040A00	040A00	-	-
		102A00,102A00	13.0	9.8/11.9	041A00	041A00	-	-
		103B00,103B00	17.4	13.1/16.0	041A00	041A00	-	-
		104B00,104B00	21.0	15.8/19.3	041A00	041A00	-	-
208/ 230-3-60	STD DD	102A00	6.5	4.9/6.0	038A00	038A00	037A00	037A00
		104B00	10.5	7.9/9.6	038A00	038A00	038A00	038A00
		105A00	16.0	12.0/14.7	038A00	038A00	038A00	038A00
		104B00,104B00	21.0	15.8/19.3	039A00	039A00	039A00	039A00
		104B00,105A00	26.5	19.9/24.3	039A00	039A00	039A00	039A00
	MED BD	102A00	6.5	4.9/6.0	038A00	038A00	038A00	037A00
		104B00	10.5	7.9/9.6	037A00	037A00	038A00	038A00
		105A00	16.0	12.0/14.7	038A00	038A00	038A00	038A00
		104B00,104B00	21.0	15.8/19.3	039A00	039A00	039A00	039A00
		104B00,105A00	26.5	19.9/24.3	039A00	039A00	039A00	039A00
	HIGH BD	102A00	6.5	4.9/6.0	038A00	038A00	037A00	037A00
		104B00	10.5	7.9/9.6	038A00	038A00	038A00	038A00
		105A00	16.0	12.0/14.7	038A00	038A00	038A00	038A00
		104B00,104B00	21.0	15.8/19.3	039A00	039A00	039A00	039A00
		104B00,105A00	26.5	19.9/24.3	039A00	039A00	039A00	039A00
460-3-60	STD DD	106A00	6.0	5.5	-	-	-	-
		108A00	11.5	10.6	-	-	-	-
		109A00	14.0	12.9	-	-	-	-
		108A00,108A00	23.0	21.1	037A00	037A00	037A00	037A00
		108A00,109A00	25.5	23.4	037A00	037A00	037A00	037A00
	MED BD	106A00	6.0	5.5	-	-	-	-
		108A00	11.5	10.6	-	-	-	-
		109A00	14.0	12.9	-	-	-	-
		108A00,108A00	23.0	21.1	037A00	037A00	037A00	037A00
		108A00,109A00	25.5	23.4	037A00	037A00	037A00	037A00
	HIGH BD	106A00	6.0	5.5	-	-	-	-
		108A00	11.5	10.6	-	-	-	-
		109A00	14.0	12.9	-	-	-	-
		108A00,108A00	23.0	21.1	037A00	037A00	037A00	037A00
		108A00,109A00	25.5	23.4	037A00	037A00	037A00	037A00

LEGEND

- No Single Point Kit required
- APP PWR - 208 / 230V / 460V / 575V
- BD - Belt drive motor
- C.O. - Convenience outlet
- DD - Drive X13 5 speed/torque motor
- FLA - Full load amps
- IFM - Indoor fan motor
- NOM PWR - 240V / 480V / 600V
- P.E. - Power exhaust
- PWRD - Powered convenience outlet
- UNPWRD - Unpowered convenience outlet

Table 14 – 50TCQA07

**ELECTRIC HEAT - ELECTRICAL DATA
SINGLE STAGE COOLING SINGLE SPEED INDOOR FAN
AND FACTORY INSTALLED NON-FUSED DISCONNECT SWITCH**

NOM. V-Ph-Hz	IFM TYPE	ELECTRIC HEATER PART NUMBER CRHEATER	NOM PWR (kW)	APP PWR (kW)	SINGLE POINT KIT PART NUMBER CRSINGLE *****			
					WITHOUT C.O. or UNPWRD C.O.		WITH PWRD C.O.	
					WITHOUT P.E.	w/ P.E. (pwrd fr/unit)	WITHOUT P.E.	w/ P.E. (pwrd fr/unit)
208/ 230-3-60	STD BD	102A00	6.5	4.9/6.0	037A00	037A00	037A00	037A00
		104B00	10.5	7.9/9.6	038A00	038A00	038A00	038A00
		105A00	16.0	12.0/14.7	038A00	038A00	038A00	038A00
		104B00,104B00	21.0	15.8/19.3	039A00	039A00	039A00	039A00
		104B00,105A00	26.5	19.9/24.3	039A00	039A00	039A00	039A00
	MED BD	102A00	6.5	4.9/6.0	037A00	037A00	037A00	038A00
		104B00	10.5	7.9/9.6	038A00	038A00	038A00	038A00
		105A00	16.0	12.0/14.7	038A00	038A00	038A00	038A00
		104B00,104B00	21.0	15.8/19.3	039A00	039A00	039A00	039A00
		104B00,105A00	26.5	19.9/24.3	039A00	039A00	039A00	039A00
	HIGH BD	102A00	6.5	4.9/6.0	037A00	037A00	037A00	038A00
		104B00	10.5	7.9/9.6	038A00	038A00	038A00	038A00
		105A00	16.0	12.0/14.7	038A00	038A00	038A00	038A00
		104B00,104B00	21.0	15.8/19.3	039A00	039A00	039A00	039A00
		104B00,105A00	26.5	19.9/24.3	039A00	039A00	039A00	039A00
460-3-60	STD BD	106A00	6.0	5.5	-	-	-	-
		108A00	11.5	10.6	-	-	-	-
		109A00	14.0	12.9	-	-	-	-
		108A00,108A00	23.0	21.1	037A00	037A00	037A00	037A00
		108A00,109A00	25.5	23.4	037A00	037A00	037A00	037A00
	MED BD	106A00	6.0	5.5	-	-	-	-
		108A00	11.5	10.6	-	-	-	-
		109A00	14.0	12.9	-	-	-	-
		108A00,108A00	23.0	21.1	037A00	037A00	037A00	037A00
		108A00,109A00	25.5	23.4	037A00	037A00	037A00	037A00
	HIGH BD	106A00	6.0	5.5	-	-	-	-
		108A00	11.5	10.6	-	-	-	-
		109A00	14.0	12.9	-	-	-	-
		108A00,108A00	23.0	21.1	037A00	037A00	037A00	037A00
		108A00,109A00	25.5	23.4	037A00	037A00	037A00	037A00

50TCQ

LEGEND

- No Single Point Kit required
- APP PWR - 208 / 230V / 460V / 575V
- C.O. - Convenience outlet
- DD - Drive X13 5 speed/torque motor
- FLA - Full load amps
- IFM - Indoor fan motor
- NOM PWR - 240V / 480V / 600V
- P.E. - Power exhaust
- PWRD - Powered convenience outlet
- UNPWRD - Unpowered convenience outlet

Table 15 – 50TCQA04

**ELECTRIC HEAT - ELECTRICAL DATA
SINGLE STAGE COOLING SINGLE SPEED INDOOR FAN
AND FACTORY INSTALLED NON-FUSED DISCONNECT SWITCH**

NOM. V-Ph-Hz	IFM TYPE	ELECTRIC HEATER PART NUMBER CRHEATER	NOM PWR (kW)	APP PWR (kW)	SINGLE POINT KIT PART NUMBER CRSINGLE *****			
					WITHOUT C.O. or UNPWRD C.O.		WITH PWRD C.O.	
					WITHOUT P.E.	w/ P.E. (pwrd fr/unit)	WITHOUT P.E.	w/ P.E. (pwrd fr/unit)
208/ 230-1-60	STD DD	101A00	4.4	3.3/4.0	037A00	037A00	-	-
		102A00	6.5	4.9/6.0	040A00	040A00	-	-
		103B00	8.7	6.5/8.0	040A00	040A00	-	-
		104B00	10.5	7.9/9.6	040A00	040A00	-	-
		102A00,102A00	13.0	9.8/11.9	041A00	041A00	-	-
208/ 230-3-60	STD DD	101A00	4.4	3.3/4.0	037A00	037A00	037A00	037A00
		102A00	6.5	4.9/6.0	037A00	037A00	037A00	037A00
		103B00	8.7	6.5/8.0	037A00	037A00	037A00	037A00
		104B00	10.5	7.9/9.6	037A00	037A00	038A00	038A00
		105A00	16.0	12.0/14.7	038A00	038A00	038A00	038A00
	MED BD	101A00	4.4	3.3/4.0	037A00	037A00	037A00	037A00
		102A00	6.5	4.9/6.0	037A00	037A00	037A00	037A00
		103B00	8.7	6.5/8.0	037A00	037A00	037A00	037A00
		104B00	10.5	7.9/9.6	037A00	037A00	037A00	038A00
		105A00	16.0	12.0/14.7	038A00	038A00	038A00	038A00
	HIGH BD	101A00	4.4	3.3/4.0	037A00	037A00	037A00	037A00
		102A00	6.5	4.9/6.0	037A00	037A00	037A00	037A00
		103B00	8.7	6.5/8.0	037A00	037A00	037A00	037A00
		104B00	10.5	7.9/9.6	037A00	037A00	037A00	038A00
		105A00	16.0	12.0/14.7	038A00	038A00	038A00	038A00
460-3-60	STD DD	106A00	6.0	5.5	-	-	-	-
		107A00	8.8	8.1	-	-	-	-
		108A00	11.5	10.6	-	-	-	-
		109A00	14.0	12.9	-	-	-	-
	MED BD	106A00	6.0	5.5	-	-	-	-
		107A00	8.8	8.1	-	-	-	-
		108A00	11.5	10.6	-	-	-	-
		109A00	14.0	12.9	-	-	-	-
	HIGH BD	106A00	6.0	5.5	-	-	-	-
		107A00	8.8	8.1	-	-	-	-
		108A00	11.5	10.6	-	-	-	-
		109A00	14.0	12.9	-	-	-	-

LEGEND

- No Single Point Kit required
- APP PWR - 208 / 230V / 460V / 575V
- BD - Belt drive motor
- C.O. - Convenience outlet
- DD - Drive X13 5 speed/torque motor
- FLA - Full load amps
- IFM - Indoor fan motor
- NOM PWR - 240V / 480V / 600V
- P.E. - Power exhaust
- PWRD - Powered convenience outlet
- UNPWRD - Unpowered convenience outlet

50TCQ

Table 16 – 50TCQA05

**ELECTRIC HEAT - ELECTRICAL DATA
SINGLE STAGE COOLING SINGLE SPEED INDOOR FAN
AND FACTORY INSTALLED NON-FUSED DISCONNECT SWITCH**

NOM. V-Ph-Hz	IFM TYPE	ELECTRIC HEATER PART NUMBER CRHEATER	NOM PWR (kW)	APP PWR (kW)	SINGLE POINT KIT PART NUMBER CRSINGLE *****			
					WITHOUT C.O. or UNPWRD C.O.		WITH PWRD C.O.	
					WITHOUT P.E.	w/ P.E. (pwrd fr/unit)	WITHOUT P.E.	w/ P.E. (pwrd fr/unit)
208/ 230-1-60	STD DD	101A00	4.4	3.3/4.0	037A00	040A00	-	-
		103B00	8.7	6.5/8.0	040A00	040A00	-	-
		102A00,102A00	13.0	9.8/11.9	041A00	041A00	-	-
		103B00,103B00	17.4	13.1/16.0	041A00	041A00	-	-
		104B00,104B00	21.0	15.8/19.3	041A00	041A00	-	-
208/ 230-3-60	STD DD	102A00	6.5	4.9/6.0	037A00	037A00	037A00	037A00
		103B00	8.7	6.5/8.0	037A00	037A00	037A00	037A00
		105A00	16.0	12.0/14.7	038A00	038A00	038A00	038A00
		104B00,104B00	21.0	15.8/19.3	039A00	039A00	039A00	039A00
	MED BD	102A00	6.5	4.9/6.0	037A00	037A00	037A00	037A00
		103B00	8.7	6.5/8.0	037A00	037A00	037A00	037A00
		105A00	16.0	12.0/14.7	038A00	038A00	038A00	038A00
		104B00,104B00	21.0	15.8/19.3	039A00	039A00	039A00	039A00
	HIGH BD	102A00	6.5	4.9/6.0	037A00	-	-	-
		103B00	8.7	6.5/8.0	037A00	037A00	037A00	037A00
		105A00	16.0	12.0/14.7	038A00	038A00	038A00	038A00
		104B00,104B00	21.0	15.8/19.3	039A00	039A00	039A00	039A00
460-3-60	STD DD	106A00	6.0	5.5	-	-	-	-
		108A00	11.5	10.6	-	-	-	-
		109A00	14.0	12.9	-	-	-	-
		108A00,108A00	23.0	21.1	037A00	037A00	037A00	037A00
	MED BD	106A00	6.0	5.5	-	-	-	-
		108A00	11.5	10.6	-	-	-	-
		109A00	14.0	12.9	-	-	-	-
		108A00,108A00	23.0	21.1	037A00	037A00	037A00	037A00
	HIGH BD	106A00	6.0	5.5	-	-	-	-
		108A00	11.5	10.6	-	-	-	-
		109A00	14.0	12.9	-	-	-	-
		108A00,108A00	23.0	21.1	037A00	037A00	037A00	037A00

50TCQ

LEGEND

- No Single Point Kit required
- APP PWR - 208 / 230V / 460V / 575V
- BD - Belt drive motor
- C.O. - Convenience outlet
- DD - Drive X13 5 speed/torque motor
- FLA - Full load amps
- IFM - Indoor fan motor
- NOM PWR - 240V / 480V / 600V
- P.E. - Power exhaust
- PWRD - Powered convenience outlet
- UNPWRD - Unpowered convenience outlet

Table 17 – 50TCQA06

**ELECTRIC HEAT - ELECTRICAL DATA
SINGLE STAGE COOLING SINGLE SPEED INDOOR FAN
AND FACTORY INSTALLED NON-FUSED DISCONNECT SWITCH**

NOM. V-Ph-Hz	IFM TYPE	ELECTRIC HEATER PART NUMBER CRHEATER	NOM PWR (kW)	APP PWR (kW)	SINGLE POINT KIT PART NUMBER CRSINGLE *****			
					WITHOUT C.O. or UNPWRD C.O.		WITH PWRD C.O.	
					WITHOUT P.E.	w/ P.E. (pwrd fr/ unit)	WITHOUT P.E.	w/ P.E. (pwrd fr/ unit)
208/ 230-1-60	STD DD	102A00	6.5	4.9/6.0	040A00	040A00	-	-
		103B00	8.7	6.5/8.0	040A00	040A00	-	-
		102A00,102A00	13.0	9.8/11.9	041A00	041A00	-	-
		103B00,103B00	17.4	13.1/16.0	041A00	041A00	-	-
		104B00,104B00	21.0	15.8/19.3	041A00	041A00	-	-
208/ 230-3-60	STD DD	102A00	6.5	4.9/6.0	038A00	038A00	037A00	037A00
		104B00	10.5	7.9/9.6	038A00	038A00	038A00	038A00
		105A00	16.0	12.0/14.7	038A00	038A00	038A00	038A00
		104B00,104B00	21.0	15.8/19.3	039A00	039A00	039A00	039A00
		104B00,105A00	26.5	19.9/24.3	039A00	039A00	039A00	039A00
	MED BD	102A00	6.5	4.9/6.0	038A00	038A00	038A00	037A00
		104B00	10.5	7.9/9.6	037A00	037A00	038A00	038A00
		105A00	16.0	12.0/14.7	038A00	038A00	038A00	038A00
		104B00,104B00	21.0	15.8/19.3	039A00	039A00	039A00	039A00
		104B00,105A00	26.5	19.9/24.3	039A00	039A00	039A00	039A00
	HIGH BD	102A00	6.5	4.9/6.0	038A00	038A00	037A00	037A00
		104B00	10.5	7.9/9.6	038A00	038A00	038A00	038A00
		105A00	16.0	12.0/14.7	038A00	038A00	038A00	038A00
		104B00,104B00	21.0	15.8/19.3	039A00	039A00	039A00	039A00
		104B00,105A00	26.5	19.9/24.3	039A00	039A00	039A00	039A00
460-3-60	STD DD	106A00	6.0	5.5	-	-	-	-
		108A00	11.5	10.6	-	-	-	-
		109A00	14.0	12.9	-	-	-	-
		108A00,108A00	23.0	21.1	037A00	037A00	037A00	037A00
		108A00,109A00	25.5	23.4	037A00	037A00	037A00	037A00
	MED BD	106A00	6.0	5.5	-	-	-	-
		108A00	11.5	10.6	-	-	-	-
		109A00	14.0	12.9	-	-	-	-
		108A00,108A00	23.0	21.1	037A00	037A00	037A00	037A00
		108A00,109A00	25.5	23.4	037A00	037A00	037A00	037A00
	HIGH BD	106A00	6.0	5.5	-	-	-	-
		108A00	11.5	10.6	-	-	-	-
		109A00	14.0	12.9	-	-	-	-
		108A00,108A00	23.0	21.1	037A00	037A00	037A00	037A00
		108A00,109A00	25.5	23.4	037A00	037A00	037A00	037A00

50TCQ

LEGEND

- No Single Point Kit required
- APP PWR - 208 / 230V / 460V / 575V
- BD - Belt drive motor
- C.O. - Convenience outlet
- DD - Drive X13 5 speed/torque motor
- FLA - Full load amps
- IFM - Indoor fan motor
- NOM PWR - 240V / 480V / 600V
- P.E. - Power exhaust
- PWRD - Powered convenience outlet
- UNPWRD - Unpowered convenience outlet

Table 18 – 50TCQA07

**ELECTRIC HEAT - ELECTRICAL DATA
SINGLE STAGE COOLING SINGLE SPEED INDOOR FAN
AND FACTORY INSTALLED NON-FUSED DISCONNECT SWITCH**

NOM. V-Ph-Hz	IFM TYPE	ELECTRIC HEATER PART NUMBER CRHEATER	NOM PWR (kW)	APP PWR (kW)	SINGLE POINT KIT PART NUMBER CRSINGLE *****			
					WITHOUT C.O. or UNPWRD C.O.		WITH PWRD C.O.	
					WITHOUT P.E.	w/ P.E. (pwrd fr/unit)	WITHOUT P.E.	w/ P.E. (pwrd fr/unit)
208/ 230-3-60	STD BD	102A00	6.5	4.9/6.0	037A00	037A00	037A00	037A00
		104B00	10.5	7.9/9.6	038A00	038A00	038A00	038A00
		105A00	16.0	12.0/14.7	038A00	038A00	038A00	038A00
		104B00,104B00	21.0	15.8/19.3	039A00	039A00	039A00	039A00
		104B00,105A00	26.5	19.9/24.3	039A00	039A00	039A00	039A00
	MED BD	102A00	6.5	4.9/6.0	037A00	037A00	037A00	038A00
		104B00	10.5	7.9/9.6	038A00	038A00	038A00	038A00
		105A00	16.0	12.0/14.7	038A00	038A00	038A00	038A00
		104B00,104B00	21.0	15.8/19.3	039A00	039A00	039A00	039A00
		104B00,105A00	26.5	19.9/24.3	039A00	039A00	039A00	039A00
	HIGH BD	102A00	6.5	4.9/6.0	037A00	037A00	037A00	038A00
		104B00	10.5	7.9/9.6	038A00	038A00	038A00	038A00
		105A00	16.0	12.0/14.7	038A00	038A00	038A00	038A00
		104B00,104B00	21.0	15.8/19.3	039A00	039A00	039A00	039A00
		104B00,105A00	26.5	19.9/24.3	039A00	039A00	039A00	039A00
460-3-60	STD BD	106A00	6.0	5.5	-	-	-	-
		108A00	11.5	10.6	-	-	-	-
		109A00	14.0	12.9	-	-	-	-
		108A00,108A00	23.0	21.1	037A00	037A00	037A00	037A00
		108A00,109A00	25.5	23.4	037A00	037A00	037A00	037A00
	MED BD	106A00	6.0	5.5	-	-	-	-
		108A00	11.5	10.6	-	-	-	-
		109A00	14.0	12.9	-	-	-	-
		108A00,108A00	23.0	21.1	037A00	037A00	037A00	037A00
		108A00,109A00	25.5	23.4	037A00	037A00	037A00	037A00
	HIGH BD	106A00	6.0	5.5	-	-	-	-
		108A00	11.5	10.6	-	-	-	-
		109A00	14.0	12.9	-	-	-	-
		108A00,108A00	23.0	21.1	037A00	037A00	037A00	037A00
		108A00,109A00	25.5	23.4	037A00	037A00	037A00	037A00

50TCQ

LEGEND

- No Single Point Kit required
- APP PWR - 208 / 230V / 460V / 575V
- C.O. - Convenience outlet
- DD - Drive X13 5 speed/torque motor
- FLA - Full load amps
- IFM - Indoor fan motor
- NOM PWR - 240V / 480V / 600V
- P.E. - Power exhaust
- PWRD - Powered convenience outlet
- UNPWRD - Unpowered convenience outlet

Table 19 – 50TCQD08

ELECTRIC HEAT - ELECTRICAL DATA
2-STAGE COOLING SINGLE SPEED INDOOR FAN MOTOR

NOM. V-Ph-Hz	IFM TYPE	ELECTRIC HEATER PART NUMBER CRHEATER	NOM PWR (kW)	APP PWR (kW)	SINGLE POINT KIT PART NUMBER CRSINGLE *****			
					WITHOUT C.O. or UNPWRD C.O.		WITH PWRD C.O.	
					WITHOUT P.E.	w/ P.E. (pwrd fr/ unit)	WITHOUT P.E.	w/ P.E. (pwrd fr/unit)
208/ 230-3-60	STD BD	117A00	10.4	7.8/9.6	049A00	049A00	049A00	049A00
		110A00	16.0	12.0/14.7	049A00	049A00	049A00	049A00
		111A00	24.8	18.6/22.8	051A00	051A00	051A00	051A00
		112A00	32.0	24.0/29.4	051A00	051A00	051A00	051A00
		112A00,117A00	42.4	31.8/38.9	053A00	053A00	053A00	053A00
	MED BD	117A00	10.4	7.8/9.6	049A00	049A00	049A00	049A00
		110A00	16.0	12.0/14.7	049A00	049A00	049A00	049A00
		111A00	24.8	18.6/22.8	051A00	051A00	051A00	051A00
		112A00	32.0	24.0/29.4	051A00	051A00	051A00	051A00
		112A00,117A00	42.4	31.8/38.9	053A00	053A00	053A00	053A00
	HIGH BD	117A00	10.4	7.8/9.6	049A00	049A00	049A00	049A00
		110A00	16.0	12.0/14.7	049A00	049A00	049A00	049A00
		111A00	24.8	18.6/22.8	051A00	051A00	051A00	051A00
		112A00	32.0	24.0/29.4	051A00	051A00	051A00	051A00
		112A00,117A00	42.4	31.8/38.9	053A00	053A00	053A00	053A00
460-3-60	STD BD	116A00	13.9	12.8	047A00	047A00	047A00	047A00
		113A00	16.5	15.2	047A00	047A00	047A00	047A00
		114A00	27.8	25.5	047A00	050A00	050A00	050A00
		115A00	33.0	30.3	050A00	050A00	050A00	050A00
		114A00,116A00	41.7	38.3	052A00	052A00	052A00	052A00
	MED BD	116A00	13.9	12.8	047A00	047A00	047A00	047A00
		113A00	16.5	15.2	047A00	047A00	047A00	047A00
		114A00	27.8	25.5	050A00	050A00	050A00	050A00
		115A00	33.0	30.3	050A00	050A00	050A00	050A00
		114A00,116A00	41.7	38.3	052A00	052A00	052A00	052A00
	HIGH BD	116A00	13.9	12.8	047A00	047A00	047A00	047A00
		113A00	16.5	15.2	047A00	047A00	047A00	047A00
		114A00	27.8	25.5	050A00	050A00	050A00	050A00
		115A00	33.0	30.3	050A00	050A00	050A00	050A00
		114A00,116A00	41.7	38.3	052A00	052A00	052A00	052A00
575-3-60	STD BD	118A00	17.0	17.0	047A00	047A00	047A00	047A00
		119A00	34.0	34.0	050A00	050A00	050A00	050A00
	MED BD	118A00	17.0	17.0	047A00	047A00	047A00	047A00
		119A00	34.0	34.0	050A00	050A00	050A00	050A00
	HIGH BD	118A00	17.0	17.0	047A00	047A00	047A00	047A00
		119A00	34.0	34.0	050A00	050A00	050A00	050A00

LEGEND

- No Single Point Kit required
- APP PWR - 208 / 230V / 460V / 575V
- C.O. - Convenience outlet
- DD - Drive X13 5 speed/torque motor
- FLA - Full load amps
- IFM - Indoor fan motor
- NOM PWR - 240V / 480V / 600V
- P.E. - Power exhaust
- PWRD - Powered convenience outlet
- UNPWRD - Unpowered convenience outlet

Table 20 – 50TCQD08

**ELECTRIC HEAT - ELECTRICAL DATA
2-STAGE COOLING WITH AND WITHOUT 2-SPEED INDOOR FAN
AND FACTORY INSTALLED NON-FUSED DISCONNECT SWITCH**

NOM. V-Ph-Hz	IFM TYPE	ELECTRIC HEATER PART NUMBER CRHEATER	NOM PWR (kW)	APP PWR (kW)	SINGLE POINT KIT PART NUMBER CRSINGLE *****			
					WITHOUT C.O. or UNPWRD C.O.		w/PWRD C.O.	
					WITHOUT P.E.	w/ P.E. (pwrd fr/ unit)	NO P.E.	w/ P.E. (pwrd fr/ unit)
208/ 230-3-60	STD BD	117A00	10.4	7.8/9.6	049A00	049A00	049A00	049A00
		110A00	16.0	12.0/14.7	049A00	049A00	049A00	049A00
		111A00	24.8	18.6/22.8	051A00	051A00	051A00	051A00
		112A00	32.0	24.0/29.4	051A00	051A00	051A00	051A00
		112A00,117A00	42.4	31.8/38.9	053A00	053A00	053A00	053A00
	MED BD	117A00	10.4	7.8/9.6	049A00	049A00	049A00	049A00
		110A00	16.0	12.0/14.7	049A00	049A00	049A00	049A00
		111A00	24.8	18.6/22.8	051A00	051A00	051A00	051A00
		112A00	32.0	24.0/29.4	051A00	051A00	051A00	051A00
		112A00,117A00	42.4	31.8/38.9	053A00	053A00	053A00	053A00
	HIGH BD	117A00	10.4	7.8/9.6	049A00	049A00	049A00	049A00
		110A00	16.0	12.0/14.7	049A00	049A00	049A00	049A00
111A00		24.8	18.6/22.8	051A00	051A00	051A00	051A00	
112A00		32.0	24.0/29.4	051A00	051A00	051A00	051A00	
112A00,117A00		42.4	31.8/38.9	053A00	053A00	053A00	053A00	
460-3-60	STD BD	116A00	13.9	12.8	047A00	047A00	047A00	047A00
		113A00	16.5	15.2	047A00	047A00	047A00	047A00
		114A00	27.8	25.5	047A00	050A00	050A00	050A00
		115A00	33.0	30.3	050A00	050A00	050A00	050A00
		114A00,116A00	41.7	38.3	052A00	052A00	052A00	052A00
	MED BD	116A00	13.9	12.8	047A00	047A00	047A00	047A00
		113A00	16.5	15.2	047A00	047A00	047A00	047A00
		114A00	27.8	25.5	050A00	050A00	050A00	050A00
		115A00	33.0	30.3	050A00	050A00	050A00	050A00
		114A00,116A00	41.7	38.3	052A00	052A00	052A00	052A00
	HIGH BD	116A00	13.9	12.8	047A00	047A00	047A00	047A00
		113A00	16.5	15.2	047A00	047A00	047A00	047A00
114A00		27.8	25.5	050A00	050A00	050A00	050A00	
115A00		33.0	30.3	050A00	050A00	050A00	050A00	
114A00,116A00		41.7	38.3	052A00	052A00	052A00	052A00	
575-3-60	STD BD	118A00	17.0	17.0	047A00	047A00	047A00	047A00
		119A00	34.0	34.0	050A00	050A00	050A00	050A00
	MED BD	118A00	17.0	17.0	047A00	047A00	047A00	047A00
		119A00	34.0	34.0	050A00	050A00	050A00	050A00
	HIGH BD	118A00	17.0	17.0	047A00	047A00	047A00	047A00
		119A00	34.0	34.0	050A00	050A00	050A00	050A00

50TCQ

LEGEND

- No Single Point Kit required
- APP PWR - 208 / 230V / 460V / 575V
- BD - Belt drive motor
- C.O. - Convenience outlet
- DD - Drive X13 5 speed/torque motor
- FLA - Full load amps
- IFM - Indoor fan motor
- NOM PWR - 240V / 480V / 600V
- P.E. - Power exhaust
- PWRD - Powered convenience outlet
- UNPWRD - Unpowered convenience outlet

Table 21 – 50TCQD09

ELECTRIC HEAT - ELECTRICAL DATA
2-STAGE COOLING SINGLE SPEED INDOOR FAN MOTOR

50TCQ

NOM. V-Ph-Hz	IFM TYPE	ELECTRIC HEATER PART NUMBER CRHEATER	NOM PWR (kW)	APP PWR (kW)	SINGLE POINT KIT PART NUMBER CRSINGLE *****			
					WITHOUT C.O. or UNPWRD C.O.		WITH PWRD C.O.	
					WITHOUT P.E.	w/ P.E. (pwrd fr/unit)	WITHOUT P.E.	w/ P.E. (pwrd fr/unit)
208/ 230-3-60	STD BD	117A00	10.4	7.8/9.6	049A00	049A00	049A00	049A00
		110A00	16.0	12.0/14.7	049A00	049A00	049A00	049A00
		111A00	24.8	18.6/22.8	051A00	051A00	051A00	051A00
		112A00	32.0	24.0/29.4	051A00	051A00	051A00	051A00
		112A00,117A00	42.4	31.8/38.9	053A00	053A00	053A00	053A00
	MED BD	117A00	10.4	7.8/9.6	049A00	049A00	049A00	049A00
		110A00	16.0	12.0/14.7	049A00	049A00	049A00	049A00
		111A00	24.8	18.6/22.8	051A00	051A00	051A00	051A00
		112A00	32.0	24.0/29.4	051A00	051A00	051A00	051A00
		112A00,117A00	42.4	31.8/38.9	053A00	053A00	053A00	053A00
	HIGH BD	117A00	10.4	7.8/9.6	049A00	049A00	049A00	049A00
		110A00	16.0	12.0/14.7	049A00	049A00	049A00	049A00
111A00		24.8	18.6/22.8	051A00	051A00	051A00	051A00	
112A00		32.0	24.0/29.4	051A00	051A00	051A00	051A00	
112A00,117A00		42.4	31.8/38.9	053A00	053A00	053A00	053A00	
460-3-60	STD BD	116A00	13.9	12.8	047A00	047A00	047A00	047A00
		113A00	16.5	15.2	047A00	047A00	047A00	047A00
		114A00	27.8	25.5	050A00	050A00	050A00	050A00
		115A00	33.0	30.3	050A00	050A00	050A00	050A00
		114A00,116A00	41.7	38.3	052A00	052A00	052A00	052A00
	MED BD	116A00	13.9	12.8	047A00	047A00	047A00	047A00
		113A00	16.5	15.2	047A00	047A00	047A00	047A00
		114A00	27.8	25.5	050A00	050A00	050A00	050A00
		115A00	33.0	30.3	050A00	050A00	050A00	050A00
		114A00,116A00	41.7	38.3	052A00	052A00	052A00	052A00
	HIGH BD	116A00	13.9	12.8	047A00	047A00	047A00	047A00
		113A00	16.5	15.2	047A00	047A00	047A00	047A00
114A00		27.8	25.5	050A00	050A00	050A00	050A00	
115A00		33.0	30.3	050A00	050A00	050A00	050A00	
114A00,116A00		41.7	38.3	052A00	052A00	052A00	052A00	
575-3-60	STD BD	118A00	17.0	17.0	047A00	047A00	047A00	047A00
		119A00	34.0	34.0	050A00	050A00	050A00	050A00
	MED BD	118A00	17.0	17.0	047A00	047A00	047A00	047A00
		119A00	34.0	34.0	050A00	050A00	050A00	050A00
	HIGH BD	118A00	17.0	17.0	047A00	047A00	047A00	047A00
		119A00	34.0	34.0	050A00	050A00	050A00	050A00

LEGEND

- No Single Point Kit required
- APP PWR - 208 / 230V / 460V / 575V
- C.O. - Convenience outlet
- DD - Drive X13 5 speed/torque motor
- FLA - Full load amps
- IFM - Indoor fan motor
- NOM PWR - 240V / 480V / 600V
- P.E. - Power exhaust
- PWRD - Powered convenience outlet
- UNPWRD - Unpowered convenience outlet

Table 22 – 50TCQD09

**ELECTRIC HEAT - ELECTRICAL DATA
2-STAGE COOLING WITH AND WITHOUT 2-SPEED INDOOR FAN
AND FACTORY INSTALLED NON-FUSED DISCONNECT SWITCH**

NOM. V-Ph-Hz	IFM TYPE	ELECTRIC HEATER PART NUMBER CRHEATER	NOM PWR (kW)	APP PWR (kW)	SINGLE POINT KIT PART NUMBER CRSINGLE *****			
					WITHOUT C.O. or UNPWRD C.O.		w/PWRD C.O.	
					WITHOUT P.E.	w/ P.E. (pwrd fr/ unit)	NO P.E.	w/ P.E. (pwrd fr/ unit)
208/ 203-3-60	STD BD	117A00	10.4	7.8/9.6	049A00	049A00	049A00	049A00
		110A00	16.0	12.0/14.7	049A00	049A00	049A00	049A00
		111A00	24.8	18.6/22.8	051A00	051A00	051A00	051A00
		112A00	32.0	24.0/29.4	051A00	051A00	051A00	051A00
		112A00,117A00	42.4	31.8/38.9	053A00	053A00	053A00	053A00
	MED BD	117A00	10.4	7.8/9.6	049A00	049A00	049A00	049A00
		110A00	16.0	12.0/14.7	049A00	049A00	049A00	049A00
		111A00	24.8	18.6/22.8	051A00	051A00	051A00	051A00
		112A00	32.0	24.0/29.4	051A00	051A00	051A00	051A00
		112A00,117A00	42.4	31.8/38.9	053A00	053A00	053A00	053A00
	HIGH BD	117A00	10.4	7.8/9.6	049A00	049A00	049A00	049A00
		110A00	16.0	12.0/14.7	049A00	049A00	049A00	049A00
111A00		24.8	18.6/22.8	051A00	051A00	051A00	051A00	
112A00		32.0	24.0/29.4	051A00	051A00	051A00	051A00	
112A00,117A00		42.4	31.8/38.9	053A00	053A00	053A00	053A00	
460-3-60	STD BD	116A00	13.9	12.8	047A00	047A00	047A00	047A00
		113A00	16.5	15.2	047A00	047A00	047A00	047A00
		114A00	27.8	25.5	050A00	050A00	050A00	050A00
		115A00	33.0	30.3	050A00	050A00	050A00	050A00
		114A00,116A00	41.7	38.3	052A00	052A00	052A00	052A00
	MED BD	116A00	13.9	12.8	047A00	047A00	047A00	047A00
		113A00	16.5	15.2	047A00	047A00	047A00	047A00
		114A00	27.8	25.5	050A00	050A00	050A00	050A00
		115A00	33.0	30.3	050A00	050A00	050A00	050A00
		114A00,116A00	41.7	38.3	052A00	052A00	052A00	052A00
	HIGH BD	116A00	13.9	12.8	047A00	047A00	047A00	047A00
		113A00	16.5	15.2	047A00	047A00	047A00	047A00
		114A00	27.8	25.5	050A00	050A00	050A00	050A00
		115A00	33.0	30.3	050A00	050A00	050A00	050A00
		114A00,116A00	41.7	38.3	052A00	052A00	052A00	052A00
575-3-60	STD BD	118A00	17.0	17.0	047A00	047A00	047A00	047A00
		119A00	34.0	34.0	050A00	050A00	050A00	050A00
	MED BD	118A00	17.0	17.0	047A00	047A00	047A00	047A00
		119A00	34.0	34.0	050A00	050A00	050A00	050A00
	HIGH BD	118A00	17.0	17.0	047A00	047A00	047A00	047A00
		119A00	34.0	34.0	050A00	050A00	050A00	050A00

50TCQ

LEGEND

- No Single Point Kit required
- APP PWR - 208 / 230V / 460V / 575V
- BD - Belt drive motor
- C.O. - Convenience outlet
- DD - Drive X13 5 speed/torque motor
- FLA - Full load amps
- IFM - Indoor fan motor
- NOM PWR - 240V / 480V / 600V
- P.E. - Power exhaust
- PWRD - Powered convenience outlet
- UNPWRD - Unpowered convenience outlet

Table 23 – 50TCQD12

ELECTRIC HEAT - ELECTRICAL DATA
2-STAGE COOLING SINGLE SPEED INDOOR FAN MOTOR

50TCQ

NOM. V-Ph-Hz	IFM TYPE	ELECTRIC HEATER PART NUMBER CRHEATER	NOM PWR (kW)	APP PWR (kW)	SINGLE POINT KIT PART NUMBER CRSINGLE *****			
					WITHOUT C.O. or UNPWRD C.O.		WITH PWRD C.O.	
					WITHOUT P.E.	w/ P.E. (pwrd fr/unit)	WITHOUT P.E.	w/ P.E. (pwrd fr/unit)
208/ 230-3-60	STD BD	117A00	10.4	7.8/9.6	049A00	049A00	049A00	051A00
		110A00	16.0	12.0/14.7	049A00	049A00	049A00	051A00
		112A00	32.0	24.0/29.4	051A00	051A00	051A00	053A00
		112A00,117A00	42.4	31.8/38.9	053A00	053A00	053A00	054A00
		112A00,110A00	50.0	37.6/45.9	053A00	053A00	053A00	054A00
	MED BD	117A00	10.4	7.8/9.6	049A00	051A00	051A00	051A00
		110A00	16.0	12.0/14.7	049A00	051A00	051A00	051A00
		112A00	32.0	24.0/29.4	051A00	053A00	053A00	053A00
		112A00,117A00	42.4	31.8/38.9	053A00	054A00	054A00	054A00
		112A00,110A00	50.0	37.6/45.9	053A00	054A00	054A00	054A00
	HIGH BD	117A00	10.4	7.8/9.6	049A00	051A00	051A00	051A00
		110A00	16.0	12.0/14.7	049A00	051A00	051A00	051A00
112A00		32.0	24.0/29.4	051A00	053A00	053A00	053A00	
112A00,117A00		42.4	31.8/38.9	053A00	054A00	054A00	054A00	
112A00,110A00		50.0	37.6/45.9	053A00	054A00	054A00	054A00	
460-3-60	STD BD	116A00	13.9	12.8	047A00	047A00	047A00	047A00
		113A00	16.5	15.2	047A00	047A00	047A00	047A00
		115A00	33.0	30.3	050A00	050A00	050A00	050A00
		114A00,116A00	41.7	38.3	052A00	052A00	052A00	052A00
		115A00,113A00	50.0	45.9	052A00	052A00	052A00	052A00
	MED BD	116A00	13.9	12.8	047A00	047A00	047A00	047A00
		113A00	16.5	15.2	047A00	047A00	047A00	047A00
		115A00	33.0	30.3	050A00	050A00	050A00	050A00
		114A00,116A00	41.7	38.3	052A00	052A00	052A00	052A00
		115A00,113A00	50.0	45.9	052A00	052A00	052A00	052A00
	HIGH BD	116A00	13.9	12.8	047A00	047A00	047A00	047A00
		113A00	16.5	15.2	047A00	047A00	047A00	047A00
115A00		33.0	30.3	050A00	050A00	050A00	050A00	
114A00,116A00		41.7	38.3	052A00	052A00	052A00	052A00	
115A00,113A00		50.0	45.9	052A00	052A00	052A00	052A00	
575-3-60	STD BD	118A00	17.0	17.0	047A00	047A00	047A00	047A00
		119A00	34.0	34.0	050A00	050A00	050A00	050A00
		118A00,119A00	51.0	51.0	052A00	052A00	052A00	052A00
	MED BD	118A00	17.0	17.0	047A00	047A00	047A00	047A00
		119A00	34.0	34.0	050A00	050A00	050A00	050A00
		118A00,119A00	51.0	51.0	052A00	052A00	052A00	052A00
	HIGH BD	118A00	17.0	17.0	047A00	047A00	047A00	047A00
		119A00	34.0	34.0	050A00	050A00	050A00	050A00
		118A00,119A00	51.0	51.0	052A00	052A00	052A00	052A00

LEGEND

- No Single Point Kit required
- APP PWR - 208 / 230V / 460V / 575V
- C.O. - Convenience outlet
- DD - Drive X13 5 speed/torque motor
- FLA - Full load amps
- IFM - Indoor fan motor
- NOM PWR - 240V / 480V / 600V
- P.E. - Power exhaust
- PWRD - Powered convenience outlet
- UNPWRD - Unpowered convenience outlet

Table 24 – 50TCQD12

**ELECTRIC HEAT - ELECTRICAL DATA
2-STAGE COOLING WITH AND WITHOUT 2-SPEED INDOOR FAN
AND FACTORY INSTALLED NON-FUSED DISCONNECT SWITCH**

NOM. V-Ph-Hz	IFM TYPE	ELECTRIC HEATER PART NUMBER CRHEATER	NOM PWR (kW)	APP PWR (kW)	SINGLE POINT KIT PART NUMBER CRSINGLE *****			
					WITHOUT C.O. or UNPWRD C.O.		w/PWRD C.O.	
					WITHOUT P.E.	w/ P.E. (pwrd fr/ unit)	NO P.E.	w/ P.E. (pwrd fr/ unit)
208/ 230-3-60	STD BD	117A00	10.4	7.8/9.6	049A00	049A00	049A00	051A00
		110A00	16.0	12.0/14.7	049A00	049A00	049A00	051A00
		112A00	32.0	24.0/29.4	051A00	051A00	051A00	053A00
		112A00,117A00	42.4	31.8/38.9	053A00	053A00	053A00	054A00
		112A00,110A00	50.0	37.6/45.9	053A00	053A00	053A00	054A00
	MED BD	117A00	10.4	7.8/9.6	049A00	051A00	051A00	051A00
		110A00	16.0	12.0/14.7	049A00	051A00	051A00	051A00
		112A00	32.0	24.0/29.4	051A00	053A00	053A00	053A00
		112A00,117A00	42.4	31.8/38.9	053A00	054A00	054A00	054A00
		112A00,110A00	50.0	37.6/45.9	053A00	054A00	054A00	054A00
	HIGH BD	117A00	10.4	7.8/9.6	049A00	051A00	051A00	051A00
		110A00	16.0	12.0/14.7	049A00	051A00	051A00	051A00
		112A00	32.0	24.0/29.4	051A00	053A00	053A00	053A00
		112A00,117A00	42.4	31.8/38.9	053A00	054A00	054A00	054A00
		112A00,110A00	50.0	37.6/45.9	053A00	054A00	054A00	054A00
460-3-60	STD BD	116A00	13.9	12.8	047A00	047A00	047A00	047A00
		113A00	16.5	15.2	047A00	047A00	047A00	047A00
		115A00	33.0	30.3	050A00	050A00	050A00	050A00
		114A00,116A00	41.7	38.3	052A00	052A00	052A00	052A00
		115A00,113A00	50.0	45.9	052A00	052A00	052A00	052A00
	MED BD	116A00	13.9	12.8	047A00	047A00	047A00	047A00
		113A00	16.5	15.2	047A00	047A00	047A00	047A00
		115A00	33.0	30.3	050A00	050A00	050A00	050A00
		114A00,116A00	41.7	38.3	052A00	052A00	052A00	052A00
		115A00,113A00	50.0	45.9	052A00	052A00	052A00	052A00
	HIGH BD	116A00	13.9	12.8	047A00	047A00	047A00	047A00
		113A00	16.5	15.2	047A00	047A00	047A00	047A00
		115A00	33.0	30.3	050A00	050A00	050A00	050A00
		114A00,116A00	41.7	38.3	052A00	052A00	052A00	052A00
		115A00,113A00	50.0	45.9	052A00	052A00	052A00	052A00
575-3-60	STD BD	118A00	17.0	17.0	047A00	047A00	047A00	047A00
		119A00	34.0	34.0	050A00	050A00	050A00	050A00
		118A00,119A00	51.0	51.0	052A00	052A00	052A00	052A00
	MED BD	118A00	17.0	17.0	047A00	047A00	047A00	047A00
		119A00	34.0	34.0	050A00	050A00	050A00	050A00
		118A00,119A00	51.0	51.0	052A00	052A00	052A00	052A00
	HIGH BD	118A00	17.0	17.0	047A00	047A00	047A00	047A00
		119A00	34.0	34.0	050A00	050A00	050A00	050A00
		118A00,119A00	51.0	51.0	052A00	052A00	052A00	052A00

50TCQ

LEGEND

- No Single Point Kit required
- APP PWR - 208 / 230V / 460V / 575V
- BD - Belt drive motor
- C.O. - Convenience outlet
- DD - Drive X13 5 speed/torque motor
- FLA - Full load amps
- IFM - Indoor fan motor
- NOM PWR - 240V / 480V / 600V
- P.E. - Power exhaust
- PWRD - Powered convenience outlet
- UNPWRD - Unpowered convenience outlet

Table 25 – 50TCQD14

ELECTRIC HEAT - ELECTRICAL DATA
2-STAGE COOLING SINGLE SPEED INDOOR FAN MOTOR

50TCQ

NOM. V-Ph-Hz	IFM TYPE	ELECTRIC HEATER PART NUMBER CRHEATER	NOM PWR (kW)	APP PWR (kW)	SINGLE POINT KIT PART NUMBER CRSINGLE *****			
					WITHOUT C.O. or UNPWRD C.O.		WITH PWRD C.O.	
					WITHOUT P.E.	w/ P.E. (pwrd fr/unit)	WITHOUT P.E.	w/ P.E. (pwrd fr/unit)
208/ 230-3-60	STD BD	291A00	16.5	12.4/15.2	051A00	051A00	051A00	051A00
		288A00,291A00	26.5	19.9/24.3	053A00	053A00	053A00	053A00
		294A00	33.5	25.2/30.8	053A00	053A00	053A00	053A00
		288A00,294A00	43.5	32.7/40.0	054A00	054A00	054A00	054A00
		291A00,294A00	50.0	37.6/45.9	054A00	054A00	054A00	054A00
	MED BD	291A00	16.5	12.4/15.2	051A00	051A00	051A00	051A00
		288A00,291A00	26.5	19.9/24.3	053A00	053A00	053A00	053A00
		294A00	33.5	25.2/30.8	053A00	053A00	053A00	053A00
		288A00,294A00	43.5	32.7/40.0	054A00	054A00	054A00	054A00
		291A00,294A00	50.0	37.6/45.9	054A00	054A00	054A00	054A00
	HIGH BD	291A00	16.5	12.4/15.2	051A00	051A00	051A00	051A00
		288A00,291A00	26.5	19.9/24.3	053A00	053A00	053A00	053A00
		294A00	33.5	25.2/30.8	053A00	053A00	053A00	053A00
		288A00,294A00	43.5	32.7/40.0	054A00	054A00	054A00	054A00
		291A00,294A00	50.0	37.6/45.9	054A00	054A00	054A00	054A00
460-3-60	STD BD	292A00	16.5	15.2	047A00	047A00	047A00	047A00
		289A00,292A00	26.5	24.3	050A00	050A00	050A00	050A00
		295A00	33.5	30.8	050A00	050A00	050A00	050A00
		289A00,295A00	43.5	40.0	052A00	052A00	052A00	052A00
		292A00,295A00	50.0	45.9	052A00	052A00	052A00	052A00
	MED BD	292A00	16.5	15.2	047A00	047A00	047A00	047A00
		289A00,292A00	26.5	24.3	050A00	050A00	050A00	050A00
		295A00	33.5	30.8	050A00	050A00	050A00	050A00
		289A00,295A00	43.5	40.0	052A00	052A00	052A00	052A00
		292A00,295A00	50.0	45.9	052A00	052A00	052A00	052A00
	HIGH BD	292A00	16.5	15.2	050A00	050A00	050A00	050A00
		289A00,292A00	26.5	24.3	050A00	050A00	050A00	050A00
		295A00	33.5	30.8	050A00	050A00	050A00	050A00
		289A00,295A00	43.5	40.0	052A00	052A00	052A00	052A00
		292A00,295A00	50.0	45.9	052A00	052A00	052A00	052A00
575-3-60	STD BD	293A00	16.5	15.2	047A00	047A00	047A00	047A00
		290A00,293A00	26.5	24.3	047A00	047A00	047A00	050A00
		296A00	33.5	30.8	050A00	050A00	050A00	050A00
		290A00,296A00	43.5	40.0	052A00	052A00	052A00	052A00
		293A00,296A00	50.0	45.9	052A00	052A00	052A00	052A00
	MED BD	293A00	16.5	15.2	047A00	047A00	047A00	047A00
		290A00,293A00	26.5	24.3	047A00	047A00	047A00	050A00
		296A00	33.5	30.8	050A00	050A00	050A00	050A00
		290A00,296A00	43.5	40.0	052A00	052A00	052A00	052A00
		293A00,296A00	50.0	45.9	052A00	052A00	052A00	052A00
	HIGH BD	293A00	16.5	15.2	047A00	047A00	047A00	047A00
		290A00,293A00	26.5	24.3	050A00	050A00	050A00	050A00
		296A00	33.5	30.8	050A00	050A00	050A00	050A00
		290A00,296A00	43.5	40.0	052A00	052A00	052A00	052A00
		293A00,296A00	50.0	45.9	052A00	052A00	052A00	052A00

LEGEND

- No Single Point Kit required
- APP PWR - 208 / 230V / 460V / 575V
- C.O. - Convenience outlet
- DD - Drive X13 5 speed/torque motor
- FLA - Full load amps
- IFM - Indoor fan motor
- NOM PWR - 240V / 480V / 600V
- P.E. - Power exhaust
- PWRD - Powered convenience outlet
- UNPWRD - Unpowered convenience outlet

Table 26 – 50TCQD14

**ELECTRIC HEAT - ELECTRICAL DATA
2-STAGE COOLING WITH AND WITHOUT 2-SPEED INDOOR FAN
AND FACTORY INSTALLED NON-FUSED DISCONNECT SWITCH**

NOM. V-Ph-Hz	IFM TYPE	ELECTRIC HEATER PART NUMBER CRHEATER	NOM PWR (kW)	APP PWR (kW)	SINGLE POINT KIT PART NUMBER CRSINGLE *****			
					WITHOUT C.O. or UNPWRD C.O.		w/PWRD C.O.	
					WITHOUT P.E.	w/ P.E. (pwrd fr/ unit)	NO P.E.	w/ P.E. (pwrd fr/ unit)
208/ 230-3-60	STD BD	291A00	16.5	12.4/15.2	051A00	051A00	051A00	051A00
		288A00,291A00	26.5	19.9/24.3	053A00	053A00	053A00	053A00
		294A00	33.5	25.2/30.8	053A00	053A00	053A00	053A00
		288A00,294A00	43.5	32.7/40.0	054A00	054A00	054A00	054A00
		291A00,294A00	50.0	37.6/45.9	054A00	054A00	054A00	054A00
	MED BD	291A00	16.5	12.4/15.2	051A00	051A00	051A00	051A00
		288A00,291A00	26.5	19.9/24.3	053A00	053A00	053A00	053A00
		294A00	33.5	25.2/30.8	053A00	053A00	053A00	053A00
		288A00,294A00	43.5	32.7/40.0	054A00	054A00	054A00	054A00
		291A00,294A00	50.0	37.6/45.9	054A00	054A00	054A00	054A00
	HIGH BD	291A00	16.5	12.4/15.2	051A00	051A00	051A00	051A00
		288A00,291A00	26.5	19.9/24.3	053A00	053A00	053A00	053A00
		294A00	33.5	25.2/30.8	053A00	053A00	053A00	053A00
		288A00,294A00	43.5	32.7/40.0	054A00	054A00	054A00	054A00
		291A00,294A00	50.0	37.6/45.9	054A00	054A00	054A00	054A00
460-3-60	STD BD	292A00	16.5	15.2	047A00	047A00	047A00	047A00
		289A00,292A00	26.5	24.3	050A00	050A00	050A00	050A00
		295A00	33.5	30.8	050A00	050A00	050A00	050A00
		289A00,295A00	43.5	40.0	052A00	052A00	052A00	052A00
		292A00,295A00	50.0	45.9	052A00	052A00	052A00	052A00
	MED BD	292A00	16.5	15.2	047A00	047A00	047A00	047A00
		289A00,292A00	26.5	24.3	050A00	050A00	050A00	050A00
		295A00	33.5	30.8	050A00	050A00	050A00	050A00
		289A00,295A00	43.5	40.0	052A00	052A00	052A00	052A00
		292A00,295A00	50.0	45.9	052A00	052A00	052A00	052A00
	HIGH BD	292A00	16.5	15.2	050A00	050A00	050A00	050A00
		289A00,292A00	26.5	24.3	050A00	050A00	050A00	050A00
		295A00	33.5	30.8	050A00	050A00	050A00	050A00
		289A00,295A00	43.5	40.0	052A00	052A00	052A00	052A00
		292A00,295A00	50.0	45.9	052A00	052A00	052A00	052A00
575-3-60	STD BD	293A00	16.5	15.2	047A00	047A00	047A00	047A00
		290A00,293A00	26.5	24.3	047A00	050A00	047A00	050A00
		296A00	33.5	30.8	050A00	050A00	050A00	050A00
		290A00,296A00	43.5	40.0	052A00	052A00	052A00	052A00
		293A00,296A00	50.0	45.9	052A00	052A00	052A00	052A00
	MED BD	293A00	16.5	15.2	047A00	047A00	047A00	047A00
		290A00,293A00	26.5	24.3	047A00	050A00	047A00	050A00
		296A00	33.5	30.8	050A00	050A00	050A00	050A00
		290A00,296A00	43.5	40.0	052A00	052A00	052A00	052A00
		293A00,296A00	50.0	45.9	052A00	052A00	052A00	052A00
	HIGH BD	293A00	16.5	15.2	047A00	047A00	047A00	047A00
		290A00,293A00	26.5	24.3	050A00	050A00	050A00	050A00
		296A00	33.5	30.8	050A00	050A00	050A00	050A00
		290A00,296A00	43.5	40.0	052A00	052A00	052A00	052A00
		293A00,296A00	50.0	45.9	052A00	052A00	052A00	052A00

50TCQ

LEGEND

- No Single Point Kit required
- APP PWR -208 / 230V / 460V / 575V
- C.O. - Convenience outlet
- DD - Drive X13 5 speed/torque motor
- FLA - Full load amps

- IFM - Indoor fan motor
- NOM PWR -240V / 480V / 600V
- PE. - Power exhaust
- PWRD - Powered convenience outlet
- UNPWRD - Unpowered convenience outlet

WEIGHTS & DIMENSIONS

50TCQ

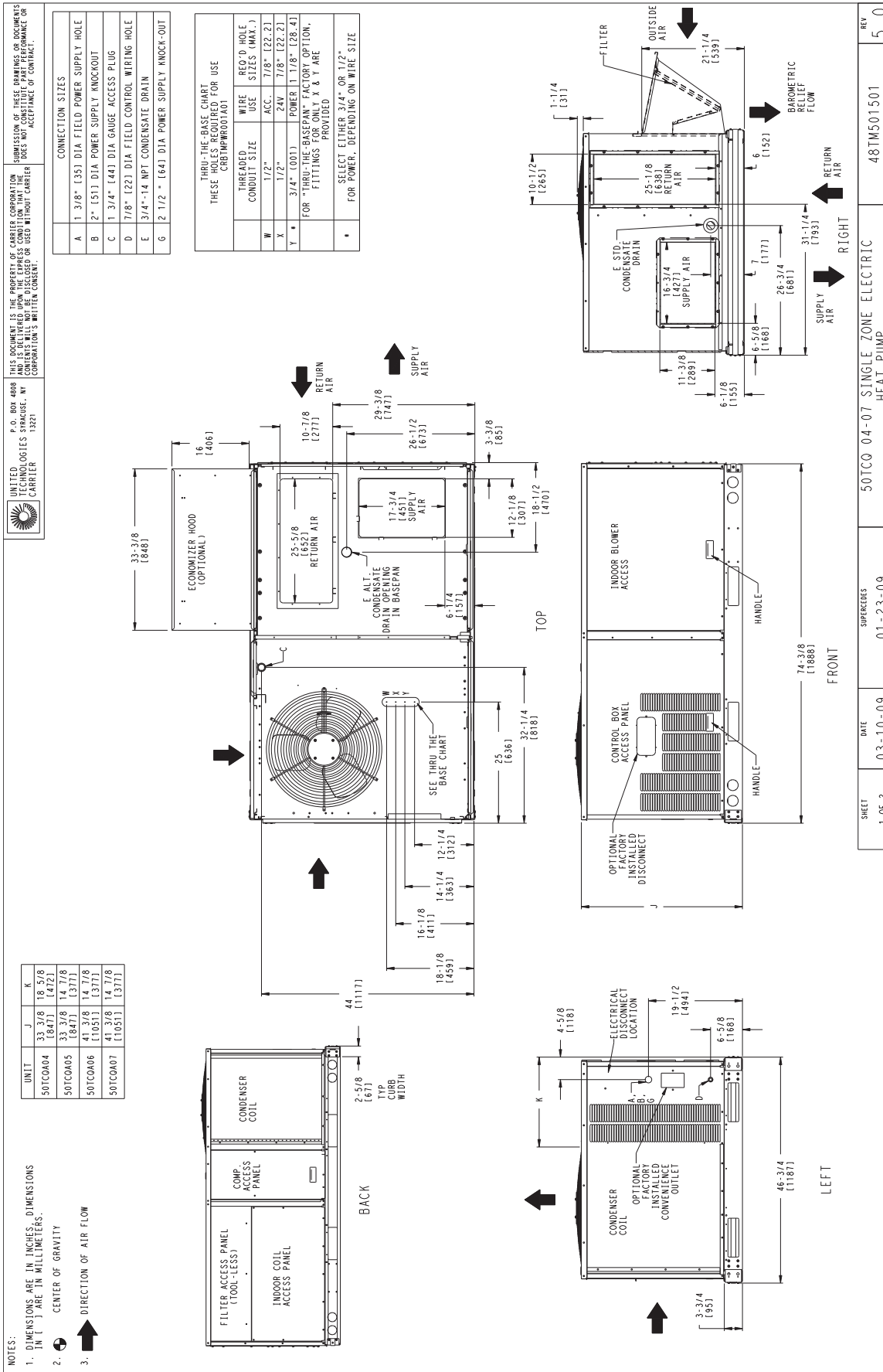
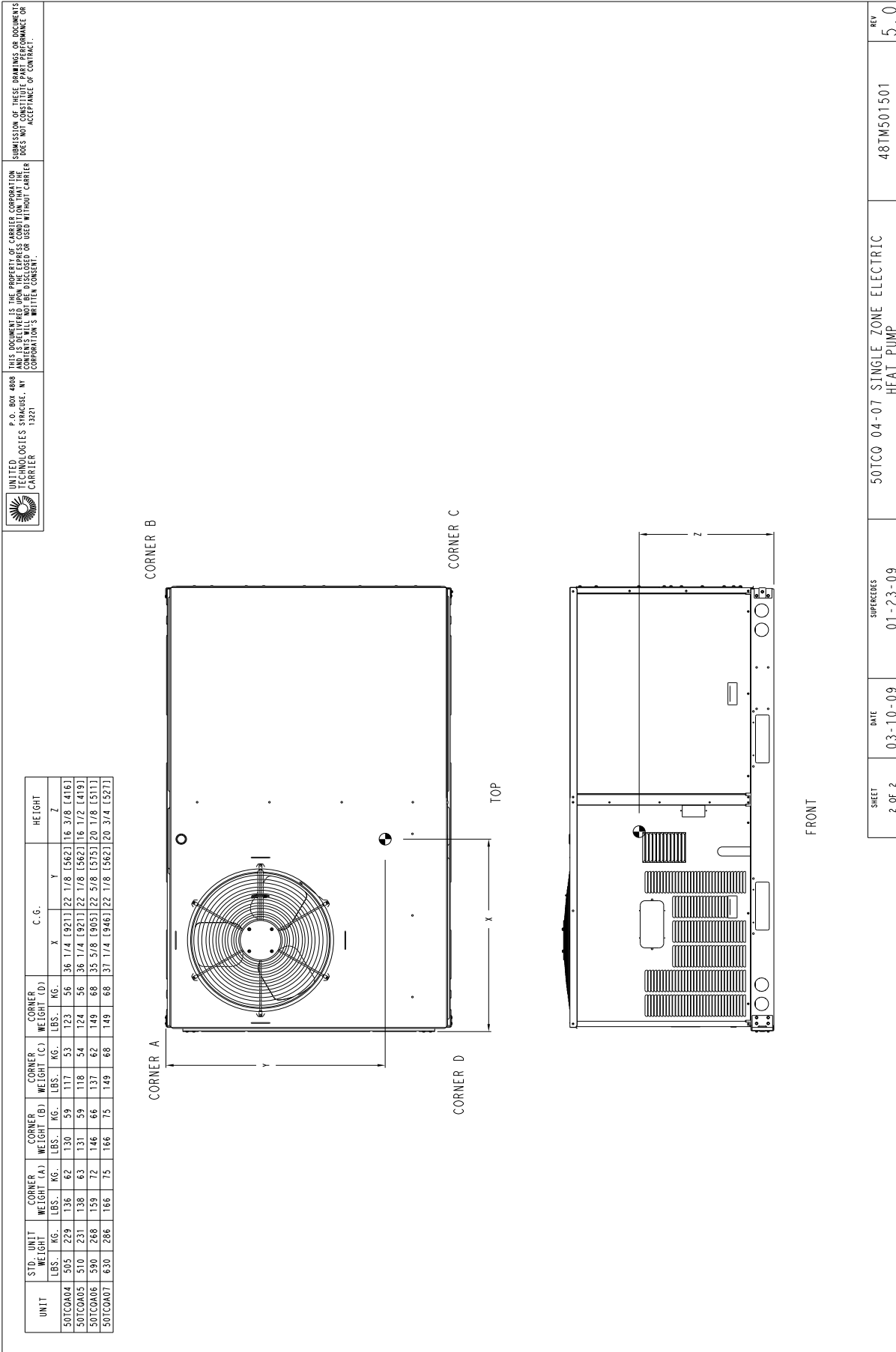

Fig. 1 - Dimensions 50TCQ 04-07

WEIGHTS & DIMENSIONS (cont.)



UNITED LOGISTICS CORPORATION
 100 W. 17th Street
 P.O. Box 4888
 White Plains, N.Y. 10601-4888
 (914) 941-1321

THIS DOCUMENT IS THE PROPERTY OF UNITED LOGISTICS CORPORATION AND IS LOANED TO YOU. IT IS NOT TO BE REPRODUCED, COPIED, OR TRANSMITTED IN ANY FORM OR BY ANY MEANS, ELECTRONIC OR MECHANICAL, INCLUDING PHOTOCOPYING, RECORDING, OR BY ANY INFORMATION STORAGE AND RETRIEVAL SYSTEM, WITHOUT THE WRITTEN CONSENT OF UNITED LOGISTICS CORPORATION.

SUBMISSION OF THESE DRAWINGS OR DOCUMENTS DOES NOT CONSTITUTE AN ACCEPTANCE OF CONTRACT.

SHEET 2 OF 2	DATE 03-10-09	SUPERSEDES 01-23-09	50TCQ 04-07 SINGLE ZONE ELECTRIC HEAT PUMP	48TMS01501	REV 5.0
-----------------	------------------	------------------------	--	------------	------------

50TCQ

Fig. 2 - Dimensions 50TCQ 04-07

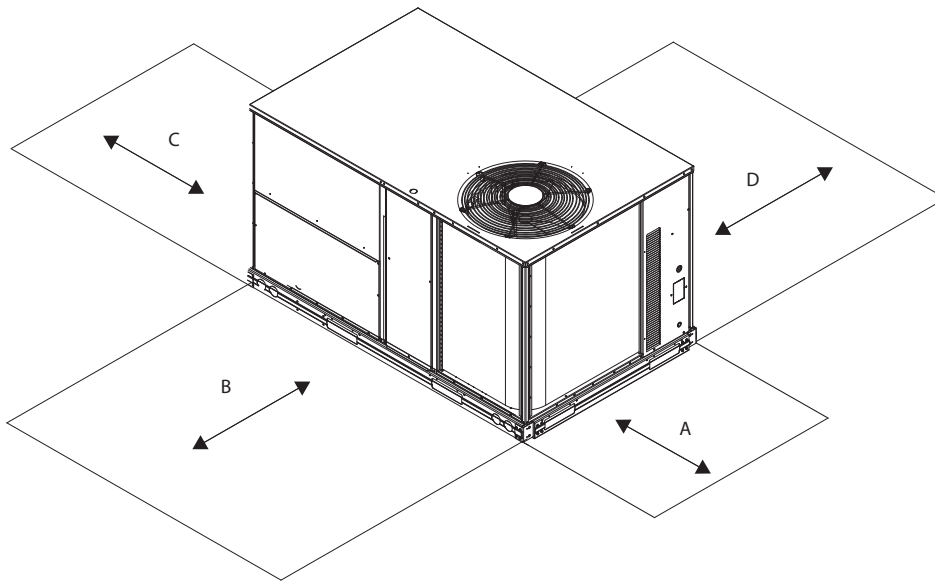

Fig. 3 - Service Clearance

C08337

LOC	DIMENSION	CONDITION
A	48-in. (1219 mm) 18-in. (457 mm) 18-in. (457 mm) 12-in. (305 mm)	Unit disconnect is mounted on panel No disconnect, convenience outlet option Recommended service clearance Minimum clearance
B	42-in. (1067 mm) 36-in. (914 mm) Special	Surface behind servicer is grounded (e.g., metal, masonry wall) Surface behind servicer is electrically non-conductive (e.g., wood, fiberglass) Check for sources of flue products within 10-ft of unit fresh air intake hood
C	36-in. (914 mm) 18-in. (457 mm)	Side condensate drain is used Minimum clearance
D	42-in. (1067 mm) 36-in. (914 mm)	Surface behind servicer is grounded (e.g., metal, masonry wall, another unit) Surface behind servicer is electrically non-conductive (e.g., wood, fiberglass)

NOTE: Unit not designed to have overhead obstruction. Contact Application Engineering for guidance on any application planning overhead obstruction or for vertical clearances.

WEIGHTS & DIMENSIONS (cont.)

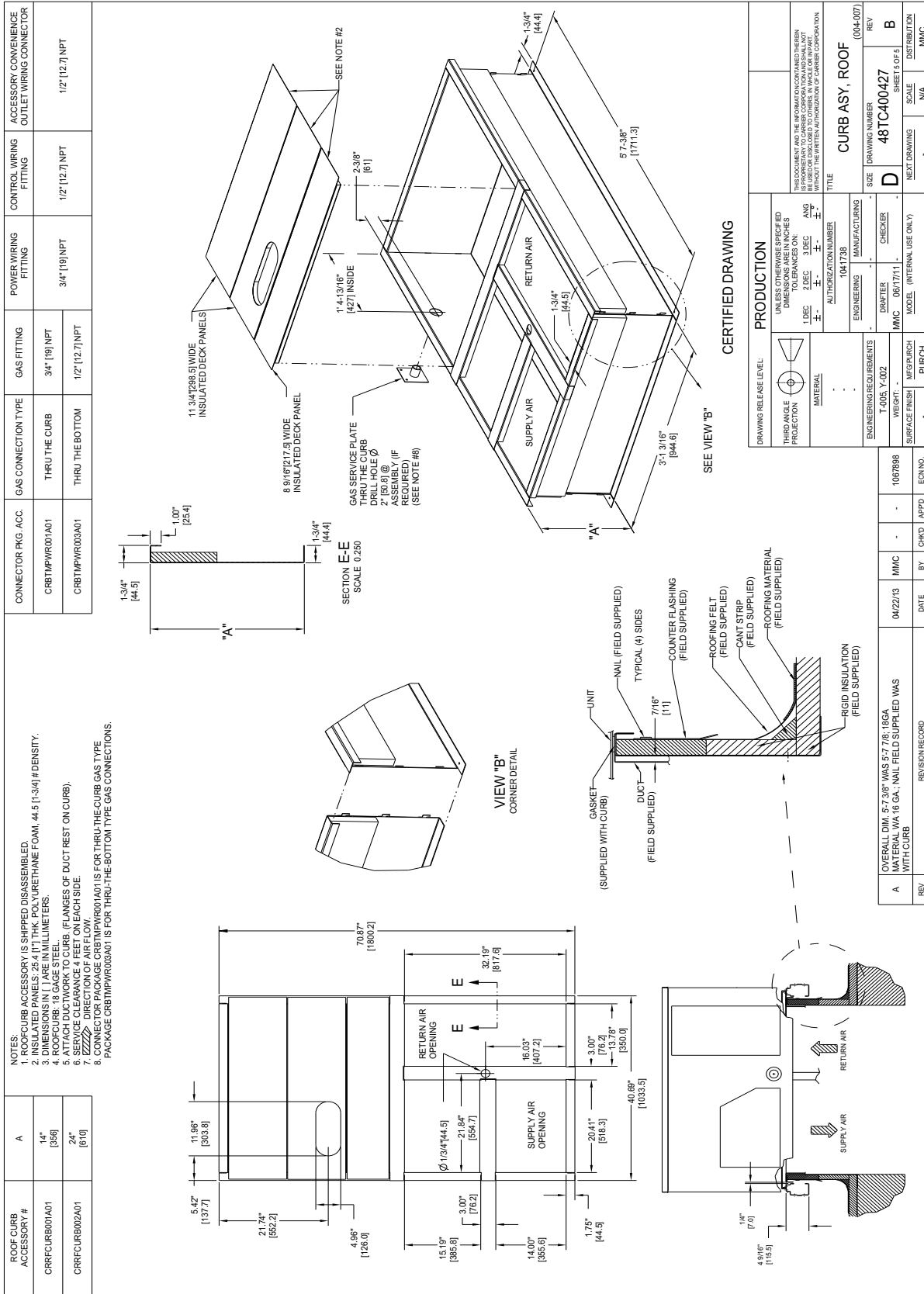

Fig. 4 - Curb Dimensions 50TCQ 04-07

50TCQ

WEIGHTS & DIMENSIONS (cont.)

50TCQ

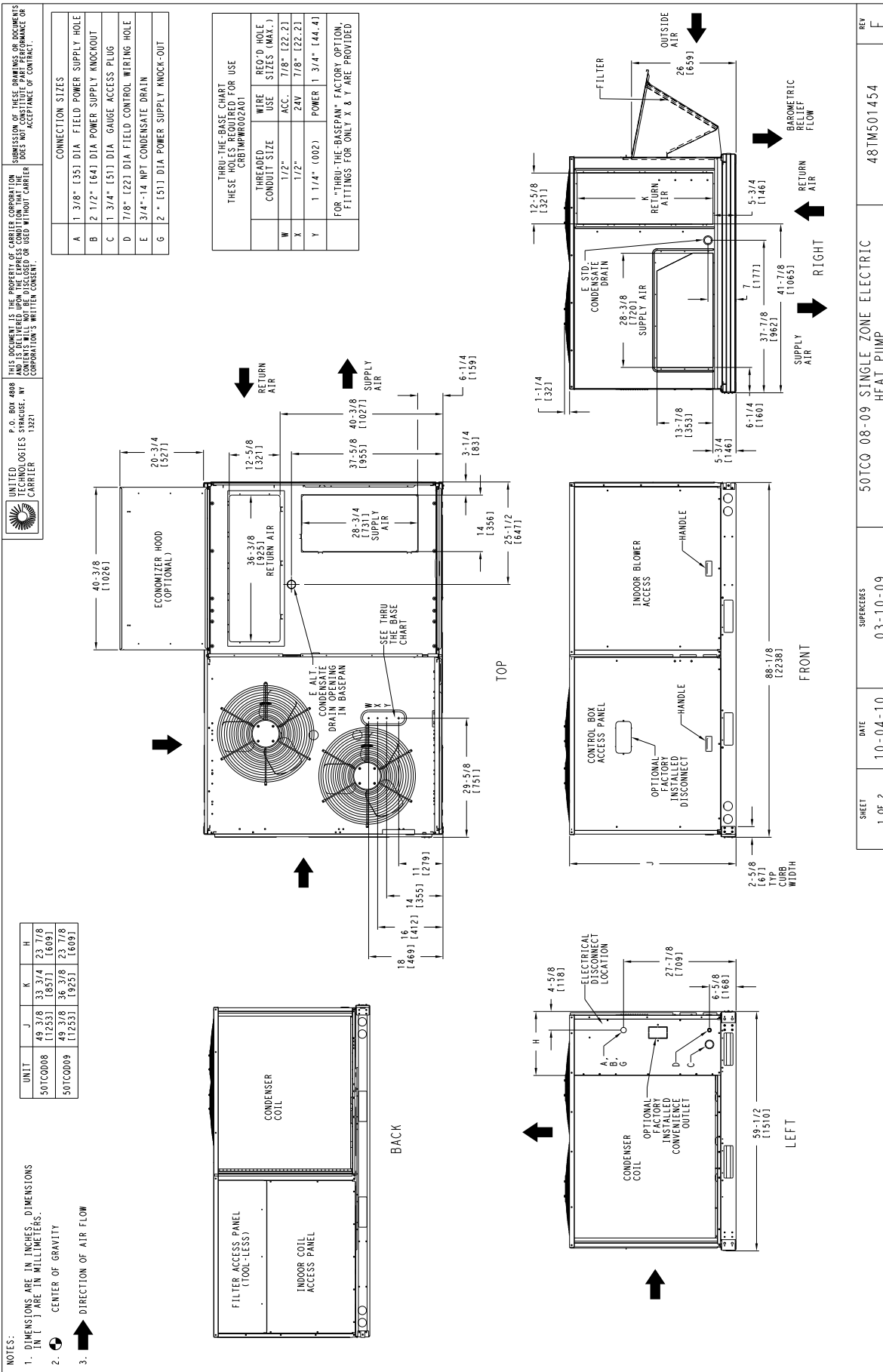
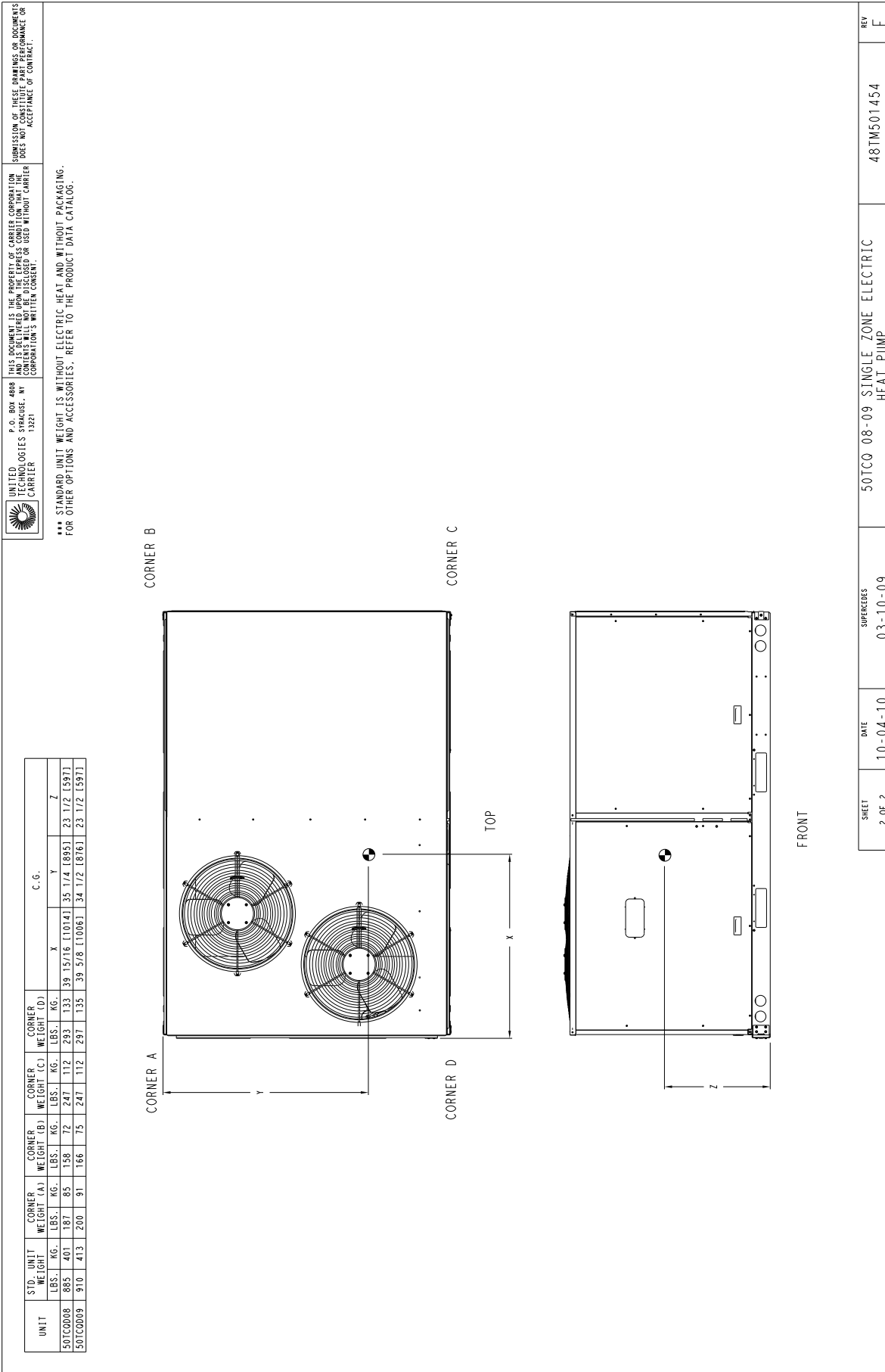

Fig. 5 - Dimensions 50TCQ 08-09

WEIGHTS & DIMENSIONS (cont.)



SHEET 2 OF 2	DATE 10-04-10	SUPERCEDES 03-10-09	50TCQ 08-09 SINGLE ZONE ELECTRIC HEAT PUMP	48TM501454	REV E
-----------------	------------------	------------------------	---	------------	----------

50TCQ

Fig. 6 - Dimensions 50TCQ 08-09

WEIGHTS & DIMENSIONS (cont.)

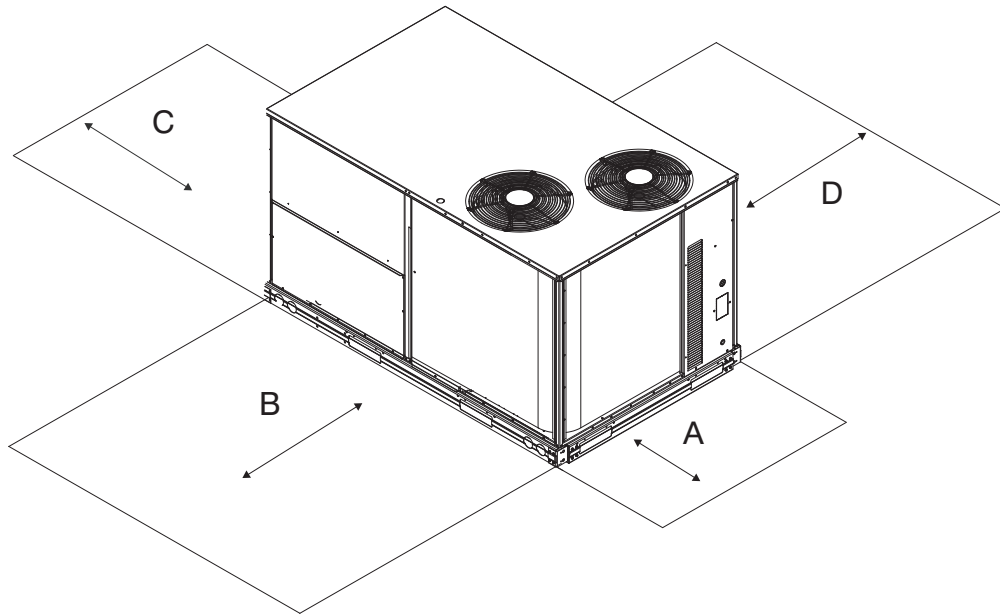

Fig. 7 - Service Clearance

C11247

LOC	DIMENSION	CONDITION
A	48-in. (1219 mm) 18-in. (457 mm) 18-in. (457 mm) 12-in. (305 mm)	Unit disconnect is mounted on panel No disconnect, convenience outlet option Recommended service clearance Minimum clearance
B	42-in. (1067 mm) 36-in. (914 mm) Special	Surface behind servicer is grounded (e.g., metal, masonry wall) Surface behind servicer is electrically non-conductive (e.g., wood, fiberglass) Check for sources of flue products within 10-ft of unit fresh air intake hood
C	36-in. (914 mm) 18-in. (457 mm)	Side condensate drain is used Minimum clearance
D	42-in. (1067 mm) 36-in. (914 mm)	Surface behind servicer is grounded (e.g., metal, masonry wall, another unit) Surface behind servicer is electrically non-conductive (e.g., wood, fiberglass)

NOTE: Unit not designed to have overhead obstruction. Contact Application Engineering for guidance on any application planning overhead obstruction or for vertical clearances.

WEIGHTS & DIMENSIONS (cont.)

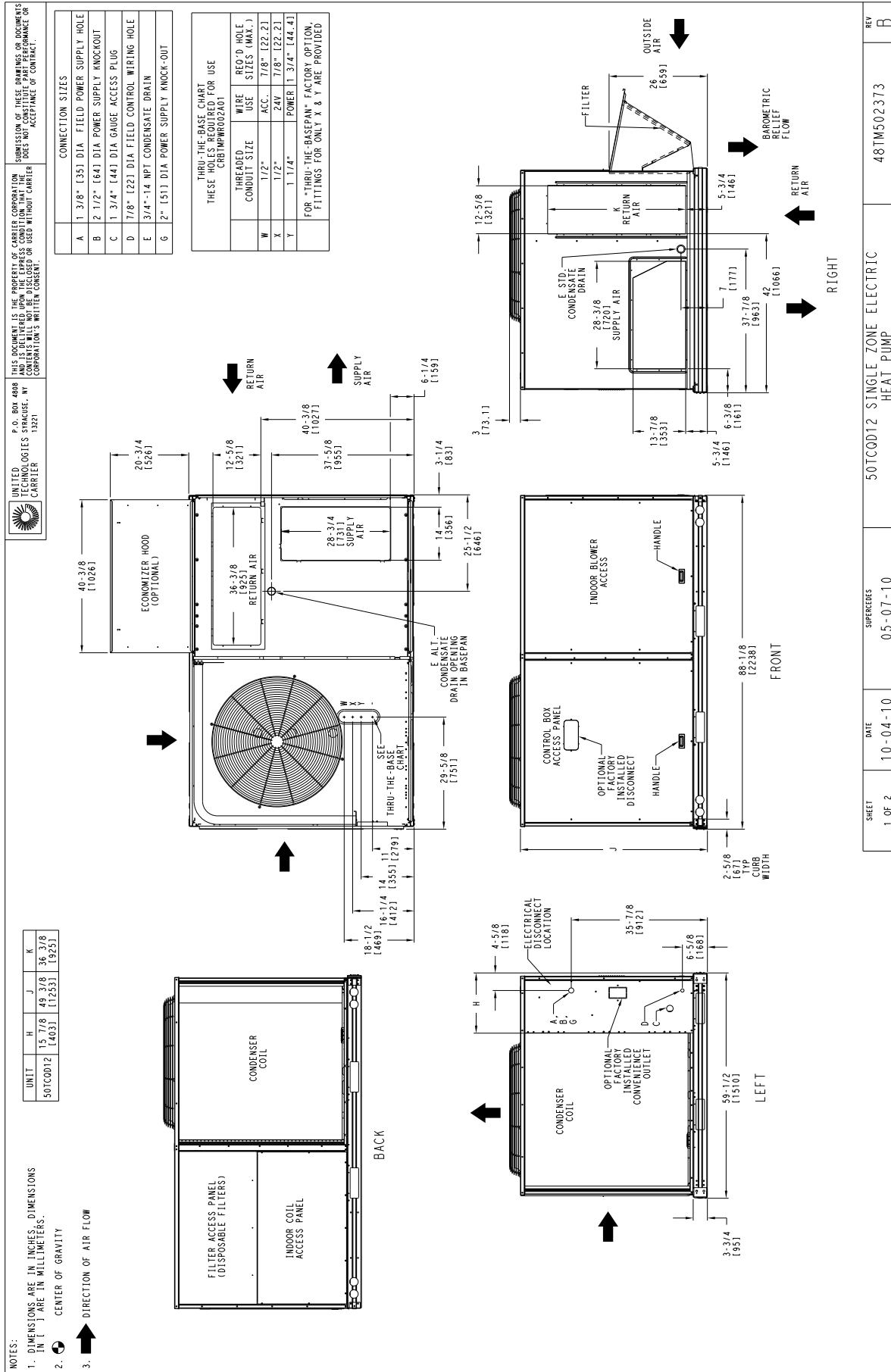

Fig. 8 - Dimensions 50TCQ 12

WEIGHTS & DIMENSIONS (cont.)

50TCQ

UNITED TECHNOLOGIES SYRACUSE, NY
 CARRIER
 P.O. BOX 4808
 THIS DOCUMENT IS THE PROPERTY OF CARRIER CORPORATION
 AND IS DELIVERED UPON THE EXPRESS CONDITION THAT THE
 INFORMATION CONTAINED HEREIN IS TO BE USED ONLY FOR THE
 PURPOSES FOR WHICH IT IS ISSUED AND NOT TO BE REPRODUCED OR
 TRANSMITTED IN ANY FORM OR BY ANY MEANS, ELECTRONIC OR
 MECHANICAL, INCLUDING PHOTOCOPYING, RECORDING, OR BY ANY
 INFORMATION STORAGE AND RETRIEVAL SYSTEM, WITHOUT THE
 WRITTEN CONSENT OF CARRIER CORPORATION.
 SUBMISSION OF THESE DRAWINGS OR DOCUMENTS
 DOES NOT CONSTITUTE AN OFFER OF INSURANCE OR
 ACCEPTANCE OF CONTRACT.

UNIT	CORNER WEIGHT*		CORNER WEIGHT (A)		CORNER WEIGHT (B)		CORNER WEIGHT (C)		CORNER WEIGHT (D)		C.G.			
	LBS.	KG.	LBS.	KG.	LBS.	KG.	LBS.	KG.	LBS.	KG.	X	Y	Z	Z
50TC0012	1050	476	284	129	201	91	234	106	331	150	36 1/2 [927]	32 [813]	23 1/2 [597]	

* STANDARD UNIT WEIGHT IS WITHOUT ELECTRIC HEAT AND WITHOUT PACKAGING. FOR OPTIONS AND ACCESSORIES REFER TO THE PRODUCT DATA CATALOG.

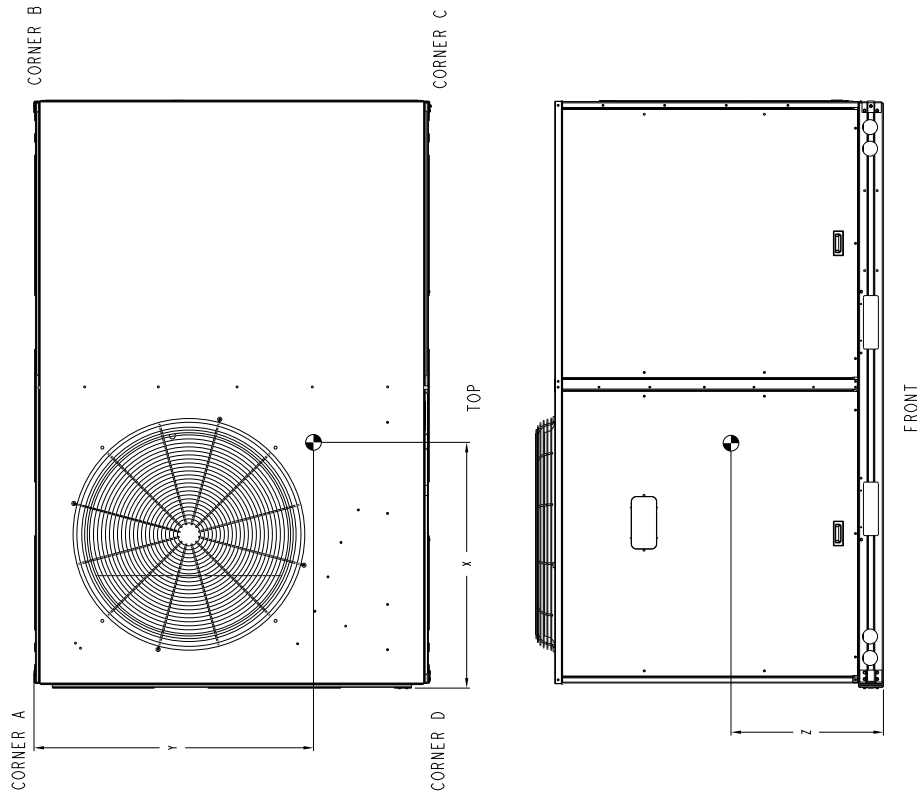

SHEET 2 OF 2	DATE 10-04-10	SUPERSEDES 05-07-10	50TC0012 SINGLE ZONE ELECTRIC HEAT PUMP	48TM502373	REV B
-----------------	------------------	------------------------	--	------------	----------

Fig. 9 - Dimensions 50TCQ 12

WEIGHTS & DIMENSIONS (cont.)

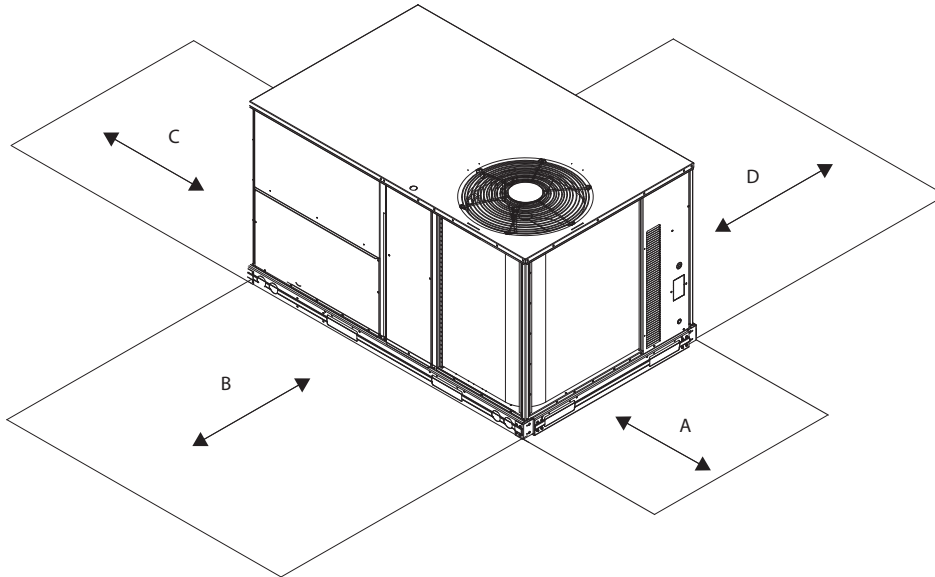

Fig. 10 - Service Clearance

C08337

50TCQ

LOC	DIMENSION	CONDITION
A	48-in. (1219 mm) 18-in. (457 mm) 18-in. (457 mm) 12-in. (305 mm)	Unit disconnect is mounted on panel No disconnect, convenience outlet option Recommended service clearance Minimum clearance
B	42-in. (1067 mm) 36-in. (914 mm) Special	Surface behind servicer is grounded (e.g., metal, masonry wall) Surface behind servicer is electrically non-conductive (e.g., wood, fiberglass) Check for sources of flue products within 10-ft of unit fresh air intake hood
C	36-in. (914 mm) 18-in. (457 mm)	Side condensate drain is used Minimum clearance
D	42-in. (1067 mm) 36-in. (914 mm)	Surface behind servicer is grounded (e.g., metal, masonry wall, another unit) Surface behind servicer is electrically non-conductive (e.g., wood, fiberglass)

NOTE: Unit not designed to have overhead obstruction. Contact Application Engineering for guidance on any application planning overhead obstruction or for vertical clearances.

WEIGHTS & DIMENSIONS (cont.)

50TCQ

UNITED TECHNOLOGIES STRATHESS, NY
 CARRIER
 P. O. BOX 4898
 THIS DOCUMENT IS THE PROPERTY OF CARRIER CORPORATION
 AND IS DELIVERED UPON THE EXPRESS CONDITION THAT THE
 USER WILL CONSIDER THESE DRAWINGS AS PERFORMANCE OR
 SUBMISSION OF THESE DRAWINGS OR COMMENTS
 HEREON WILL BE CONSIDERED AS AN ACCEPTANCE OF CONTRACT.

UNIT	CORNER WEIGHT (A)		CORNER WEIGHT (B)		CORNER WEIGHT (C)		CORNER WEIGHT (D)		C.G.					
	LBS.	KG.	LBS.	KG.	LBS.	KG.	LBS.	KG.	X	Y	Z			
50TCQ014	1370	623	369	168	361	164	324	147	57 1/2	1460	29 1/2	1750	24	1610

STANDARD UNIT WEIGHT IS WITHOUT ELECTRIC HEAT & WITHOUT PACKAGING.
FOR OPTIONS & ACCESSORIES, REFER TO THE PRODUCT DATA CATALOG.

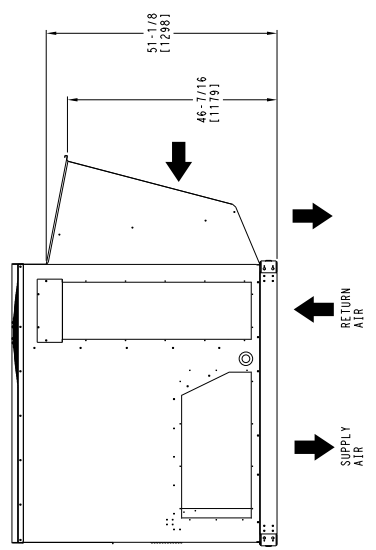
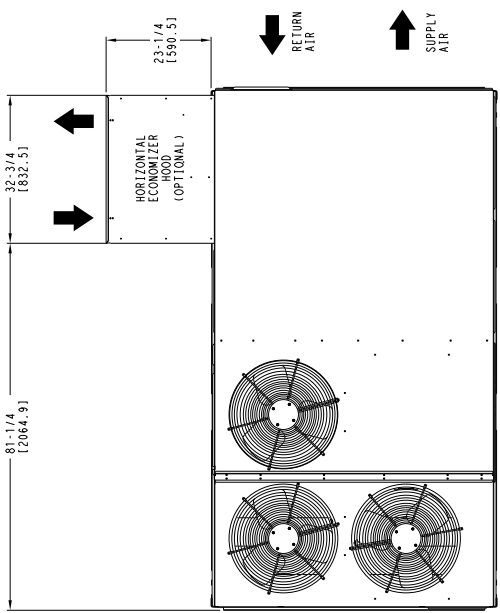
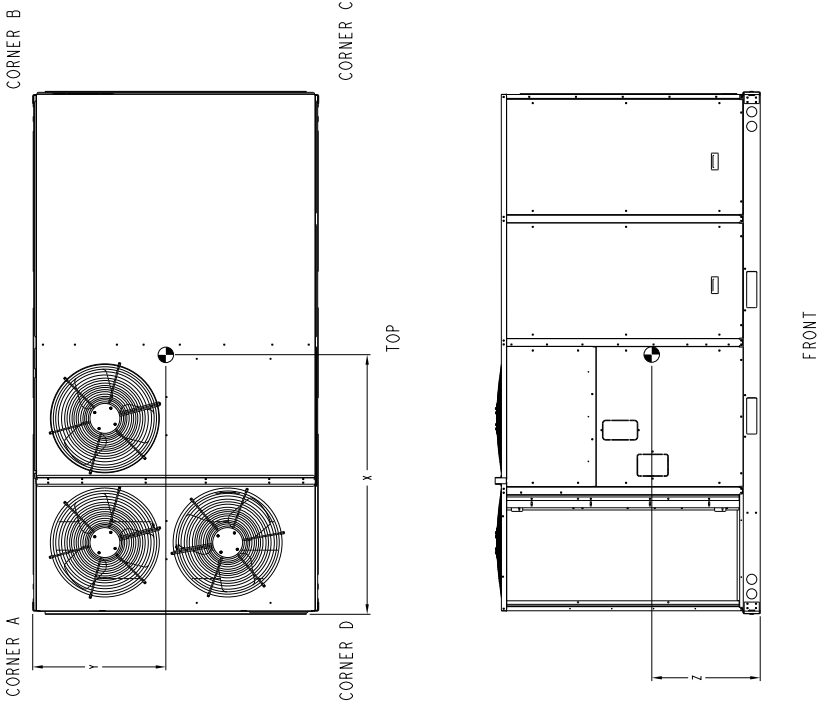

HORIZONTAL ECONOMIZER

DATE 05/22/12	SUPERCEDES -	50TCQ 14 SINGLE ZONE ELECTRIC HEAT PUMP	50TM500765	REV B
------------------	-----------------	--	------------	----------

Fig. 13 - Dimensions 50TCQ 14

WEIGHTS & DIMENSIONS (cont.)

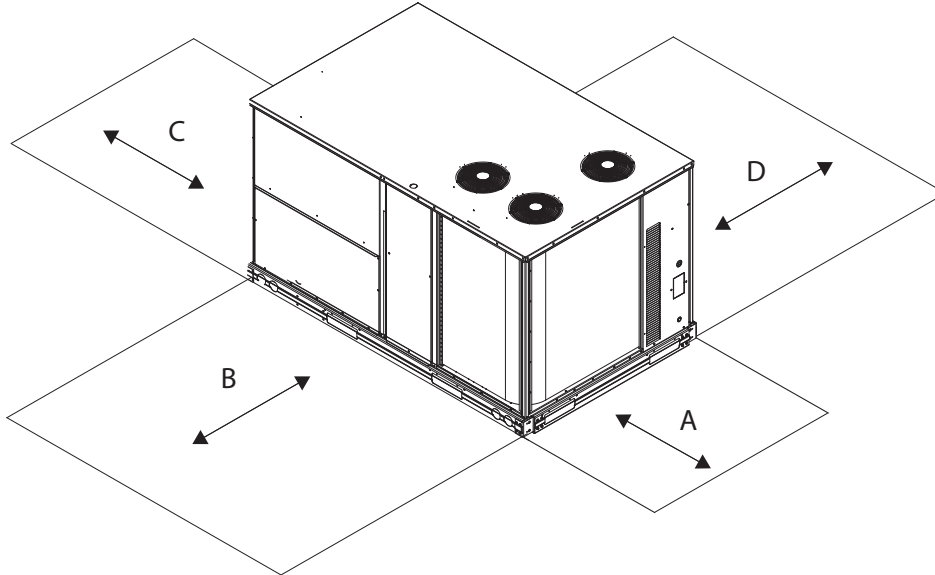

Fig. 14 - Service Clearance

C10578B

50TCQ

LOC	DIMENSION	CONDITION
A	48-in. (1219 mm) 18-in. (457 mm) 18-in. (457 mm) 12-in. (305 mm)	Unit disconnect is mounted on panel No disconnect, convenience outlet option Recommended service clearance Minimum clearance
B	42-in. (1067 mm) 36-in. (914 mm) Special	Surface behind servicer is grounded (e.g., metal, masonry wall) Surface behind servicer is electrically non-conductive (e.g., wood, fiberglass) Check for sources of flue products within 10-ft of unit fresh air intake hood
C	36-in. (914 mm) 18-in. (457 mm)	Side condensate drain is used Minimum clearance
D	42-in. (1067 mm) 36-in. (914 mm)	Surface behind servicer is grounded (e.g., metal, masonry wall, another unit) Surface behind servicer is electrically non-conductive (e.g., wood, fiberglass)

NOTE: Unit not designed to have overhead obstruction. Contact Application Engineering for guidance on any application planning overhead obstruction or for vertical clearances.

WEIGHTS & DIMENSIONS (cont.)

50TCQ

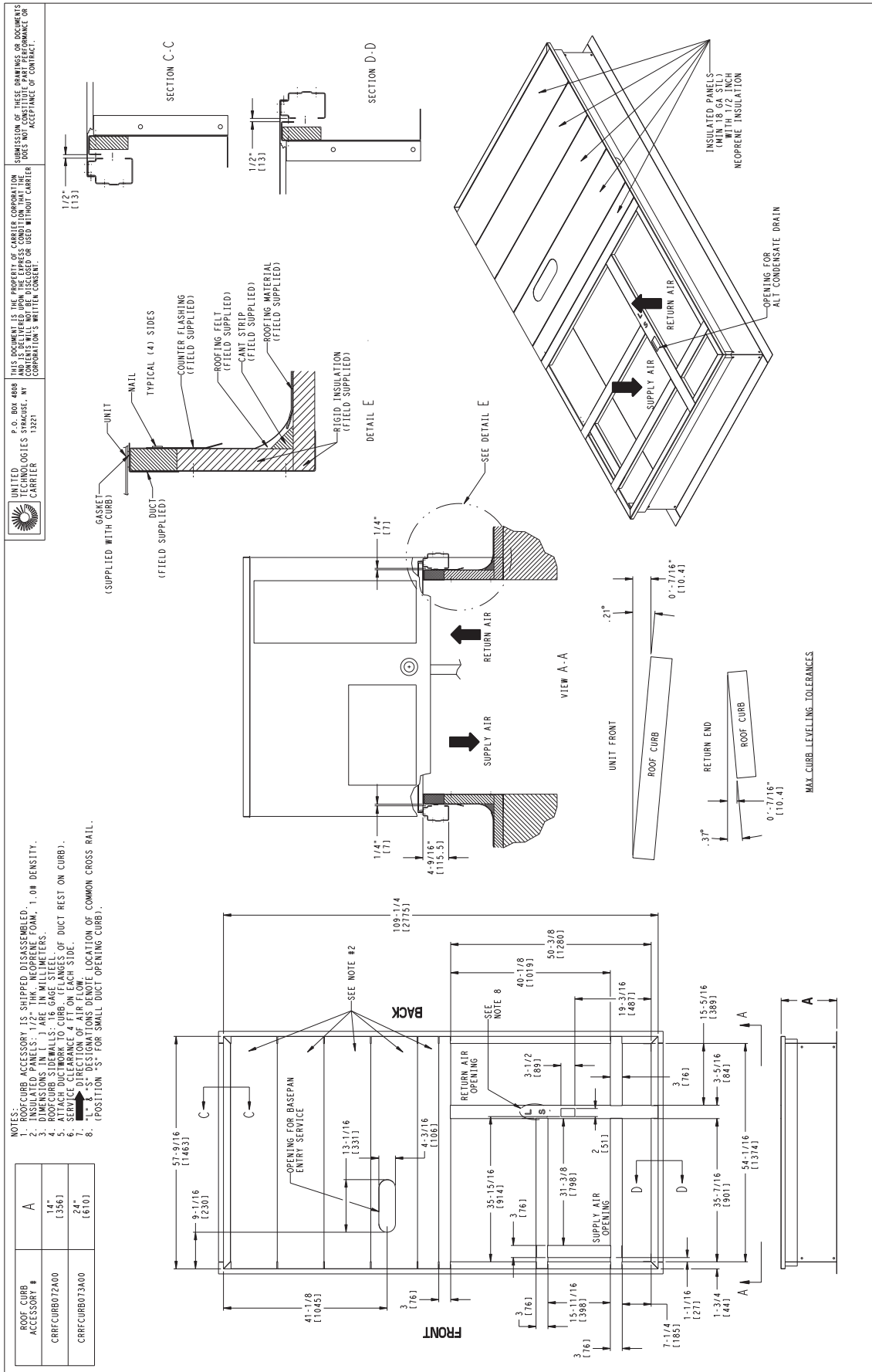

Fig. 15 - Curb Dimensions 50TCQ 14

C10365

OPTION / ACCESSORY WEIGHTS

OPTION / ACCESSORY	OPTION / ACCESSORY WEIGHTS															
	04		05		06		07		08		09		12		14	
	lb	kg	lb	kg	lb	kg	lb	kg	lb	kg	lb	kg	lb	kg	lb	kg
Power Exhaust – vertical	50	23	50	23	50	23	50	23	75	34	75	34	75	34	85	39
Power Exhaust – horizontal	30	14	30	14	30	14	30	14	30	14	30	14	30	14	75	34
EconoMi\$er (IV, X or 2)	50	23	50	23	50	23	50	23	75	34	75	34	75	34	115	52
Two Position damper	39	18	39	18	39	18	39	18	58	26	58	26	58	26	65	29
Manual Dampers	12	5	12	5	12	5	12	5	18	8	18	8	18	8	25	11
Hail Guard (louvered)	16	7	16	7	16	7	16	7	34	15	34	15	34	15	45	20
Cu/Cu Condenser Coil	35	16	35	16	35	16	95	43	95	43	95	43	170	77	190	86
Cu/Cu Cond. & Evaporator Coils	60	27	60	27	90	41	165	75	140	64	195	88	270	122	280	127
Roof Curb (14-in. curb)	115	52	115	52	115	52	115	52	143	65	143	65	143	65	180	82
Roof Curb (24-in. curb)	197	89	197	89	197	89	197	89	245	111	245	111	245	111	255	116
CO ₂ sensor	5	2	5	2	5	2	5	2	5	2	5	2	5	2	5	2
Electric Heater	30	14	30	14	30	14	30	14	45	20	45	20	45	20	25	11
Single Point Kit	10	5	10	5	10	5	10	5	12	5	12	5	12	5	25	11
Optional Indoor Motor / Drive	10	5	10	5	10	5	10	5	15	7	15	7	15	7	45	20
Motormaster Controller	35	16	35	16	35	16	35	16	35	16	35	16	35	16	35	16
Return Smoke Detector	5	2	5	2	5	2	5	2	5	2	5	2	5	2	5	2
Supply Smoke Detector	5	2	5	2	5	2	5	2	5	2	5	2	5	2	5	2
Non-Fused Disconnect	15	7	15	7	15	7	15	7	15	7	15	7	15	7	15	7
Powered Convenience outlet	35	16	35	16	35	16	35	16	35	16	35	16	35	16	35	16
Non-Powered Convenience outlet	5	2	5	2	5	2	5	2	5	2	5	2	5	2	4	2
Enthalpy Sensor	2	1	2	1	2	1	2	1	2	1	2	1	2	1	2	1
Differential Enthalpy Sensor	3	1	3	1	3	1	3	1	3	1	3	1	3	1	3	1
SAV System with VFD	–	–	–	–	–	–	–	–	20	9	20	9	20	9	20	9

50TCQ

NOTE: Where multiple variations are available, the heaviest combination is listed.
 – Not Available

APPLICATION DATA

Min operating ambient temp (cooling):

In mechanical cooling mode, your Carrier rooftop can safely operate down to an outdoor ambient temperature of 25°F (-4°C). It is possible to provide cooling at lower outdoor ambient temperatures by using less outside air, economizers, and/or accessory low ambient kits.

Max operating ambient temp (cooling):

The maximum operating ambient temperature for cooling mode is 115°F (46°C). While cooling operation above 115°F (46°C) may be possible, it could cause either a reduction in performance, reliability, or a protective action by the unit's internal safety devices.

Min and max airflow (cooling mode):

To maintain safe and reliable operation of your rooftop, operate within the cooling airflow limits. Operating above the max may cause blow-off, undesired airflow noise, or airflow related problems with the rooftop unit. Operating below the min may cause problems with coil freeze-up.

Airflow:

All units are draw-through in cooling mode.

Outdoor air application strategies:

Economizers reduce operating expenses and compressor run time by providing a free source of cooling and a means of ventilation to match application changing needs. In fact, they should be considered for most applications. Also, consider the various economizer control methods and their benefits, as well as sensors required to accomplish your application goals. Please contact your local Carrier representative for assistance.

Motor limits, Brake horsepower (BHP):

Due to Carrier's internal unit design, air path, and specially designed motors, the full horsepower (maximum continuous BHP) band, as listed in this manual, can be used with the utmost confidence. There is no need for extra safety factors, as Carrier's motors are designed and rigorously tested to use the entire, listed BHP range without either nuisance tripping or premature motor failure.

Sizing a rooftop

Bigger isn't necessarily better. While an air conditioner needs to have enough capacity to meet the load, it doesn't need excess capacity. In fact, having excess capacity typically results in very poor part load performance and humidity control.

Using higher design temperatures than ASHRAE recommends for your location, adding "safety factors" to the calculated load, and rounding up to the next largest unit, are all signs of oversizing air conditioners. Oversizing can cause short-cycling, and short cycling leads to poor humidity control, reduced efficiency, higher utility bills, drastic indoor temperature swings, excessive noise, and increased wear and tear on the air conditioner.

Rather than oversizing an air conditioner, wise contractors and engineers "right-size" or even slightly undersize air conditioners. Correctly sizing an air conditioner controls humidity better; promotes efficiency; reduces utility bills; extends equipment life, and maintains even, comfortable temperatures.

Low ambient applications

When equipped with a Carrier economizer, your rooftop unit can cool your space by bringing in fresh, cool outside air. In fact, when so equipped, accessory low ambient kit may not be necessary. In low ambient conditions, unless the outdoor air is excessively humid or contaminated, economizer-based "free cooling" is the preferred less costly and energy conscious method.

In low ambient applications where outside air might not be desired (such as contaminated or excessively humid outdoor environments), your Carrier rooftop can operate at ambient temperatures down to -20°F (-29°C) using the recommended accessory Motormaster low ambient controller.

50TCQ - Staged Air volume (SAV) - Variable Frequency Drive (VFD) HP Rating

UNIT SIZE	VOLTAGE	STATIC OPTION	VFD HP RATING
08	208/230, 460, 575	STD	3
	208/230, 460	MED	3
	575	MED	5
	208/230, 460	HIGH	3
	575	HIGH	5
09	208/230, 460, 575	STD	3
	208/230, 460	MED	3
	575	MED	5
	208/230, 460	HIGH	3
	575	HIGH	5
12	208/230, 460, 575	STD	3
	208/230, 460, 575	MED	5
	208/230, 460, 575	HIGH	7.5
14	208/230, 460	STD	3
	575	STD	5
	208/230, 460	MED	3
	575	MED	5
	208/230, 460, 575	HIGH	7.5

50TCQ

SELECTION PROCEDURE (WITH 50TCQA07 EXAMPLE)

(Selection software by Carrier saves time by performing many of the steps below.)

I. Determine cooling and heating loads.

Given:

Mixed Air Drybulb	80°F (27°C)
Mixed Air Wetbulb	67°F (19°C)
Ambient Drybulb	95°F (35°C)
TC _{Load}	65.0 MBH
SHC _{Load}	46.0 MBH
HC _{Load}	45.0 MBH
Outdoor-Air Winter Design Temp	0°F (-18°C)
Indoor Air Winter Design Temp	70°F (21°C)
Vertical Supply Air	2100 CFM
External Static Pressure	0.66 in.wg
Electrical Characteristics	230-3-60

$$\frac{20,700 \text{ Btuh}}{3413 \text{ Btuh/kW}} = 6.1 \text{ kW of heat required.}$$

Enter the Electric Heating Capacities table for 50TC-QA07 at 208/230, 3-phase. The 6.5-kW heater at 230V most closely satisfies the heating required.

$$6.5 \text{ kW} \times 3413 = 22,185 \text{ Btuh}$$

Total unit heating capacity is 46,485 Btuh (22,185 + 24,300).

VI. Calculate RTU Latent Heat Capacity

$$LC = TC - SHC$$

$$LC = 69.0 \text{ MBH} - 50.7 \text{ MBH} = 18.3 \text{ MBH}$$

VII. Compare RTU capacities to loads.

Compare the rooftop's SHC and LC to the building's Sensible and Latent Heat Loads.

See Notes 1 and 2.

VIII. Select factory options (FIOP)

Local code requires an economizer for any unit with TC larger than 65.0 MBH.

IX. Calculate the total static pressure.

External static pressure	0.66 in. wg
Sum of FIOP/Accessory static	+0.14 in. wg
Total Static Pressure	0.80 in. wg

X. Look up the Indoor Fan RPM & BHP.

Table 56 shows, at 2100 CFM & ESP= 0.8, RPM = 1268 & BHP = 1.52

XI. Determine electrical requirements

TABLE 97 shows the MCA and MOCP of a 50TC-QA07 (without convenience outlet) with 6.5 kW electric heater as:

MCA = 52.3 amps & MOCP = 60 amps
Min. Disconnect Size: FLA = 50 & LRA = 199.

II. Make an initial guess at cooling tons.

Refrig. tons = TC_{Load} / 12 MBH per ton
Refrig. tons = 65.0 / 12 = 5.42 tons

In this case, start by looking at the 50TCQA07.

III. Look up the rooftop's TC and SHC.

Table 22 shows that, at the application's supply air CFM, mixed air and ambient temperatures, the 50TC-QA07 supplies:

$$TC_{\text{Load}} = 69.0 \text{ MBH}$$

$$SHC_{\text{Load}} = 50.7 \text{ MBH.}$$

IV. Calculate RTU Latent Heat Capacity

$$LC_{\text{Load}} = TC_{\text{Load}} - SHC_{\text{Load}}$$

$$LC_{\text{Load}} = 65.0 \text{ MBH} - 46.0 \text{ MBH} = 19.0 \text{ MBH}$$

V. Select electric heat.

Enter the Instantaneous and Integrated Heating Ratings, Table 30 at 2100 cfm. At 70°F (21°C return indoor air and 0°F (-18°C) air entering outdoor coil, the integrated heating capacity after interpolation, is 24,300 BTUH. (Select integrated heating capacity value since deductions for outdoor-coil frost and defrosting have already been made. No correction is required.)

The required heating capacity is 45,000 Btuh. Therefore, 20,700 Btuh (45,000 – 24,300) additional electric heat is required. Determine additional electric heat capacity in kW.

NOTES:

1. Selecting a unit with a SHC slightly lower than the SHC_{Load} is often better than oversizing. Slightly lower SHC's will help control indoor humidity, and prevent temperature swings.

2. If the rooftop's capacity meets the Sensible Heat Load, but not the Latent Heat Load.

LEGEND:	
BHP – Brake horsepower	MCA – Minimum circuit ampacity
FLA – Full load amps	MOCP – Maximum over-current protection
HC – Heating Capacities	RPM – Revolutions per minute
LC – Latent capacity	RTU – Rooftop unit
LRA – Lock rotor amp	SHC – Sensible heat capacity
MBH – (1,000) BTUH	THC – Total capacity

Table 27 – COOLING CAPACITIES

1-STAGE COOLING

3 TONS

50TCQA04			AMBIENT TEMPERATURE												
			85			95			105			115			
			EAT (db)			EAT (db)			EAT (db)			EAT (db)			
			75	80	85	75	80	85	75	80	85	75	80	85	
900 Cfm	EAT (wb)	58	THC	31.4	31.4	35.7	29.6	29.6	33.6	27.6	27.6	31.5	25.6	25.6	29.1
		SHC	27.1	31.4	35.7	25.5	29.6	33.6	23.8	27.6	31.5	22.0	25.6	29.1	
	62	THC	33.5	33.5	34.4	30.9	30.9	33.2	28.3	28.3	31.9	25.7	25.7	30.4	
		SHC	24.8	29.6	34.4	23.6	28.4	33.2	22.3	27.1	31.9	20.9	25.7	30.4	
	67	THC	38.0	38.0	38.0	35.3	35.3	35.3	32.4	32.4	32.4	29.4	29.4	29.4	
		SHC	21.0	25.8	30.7	19.8	24.6	29.5	18.6	23.4	28.2	17.3	22.2	27.0	
72	THC	42.1	42.1	42.1	39.7	39.7	39.7	37.1	37.1	37.1	34.0	34.0	34.0		
	SHC	16.7	21.6	26.4	15.8	20.6	25.5	14.7	19.6	24.4	13.6	18.4	23.2		
76	THC	-	44.9	44.9	-	43.0	43.0	-	40.5	40.5	-	37.5	37.5		
	SHC	-	17.8	22.7	-	17.1	22.0	-	16.2	21.1	-	15.2	20.1		
1050 Cfm	EAT (wb)	58	THC	33.7	33.7	38.3	31.7	31.7	36.0	29.6	29.6	33.6	27.4	27.4	31.2
		SHC	29.1	33.7	38.3	27.3	31.7	36.0	25.5	29.6	33.6	23.6	27.4	31.2	
	62	THC	35.0	35.0	38.1	32.3	32.3	36.7	29.7	29.7	35.1	27.4	27.4	32.5	
		SHC	26.9	32.5	38.1	25.6	31.2	36.7	24.2	29.7	35.1	22.4	27.4	32.5	
	67	THC	39.4	39.4	39.4	36.7	36.7	36.7	33.7	33.7	33.7	30.5	30.5	30.5	
		SHC	22.4	28	33.6	21.2	26.8	32.4	20.0	25.6	31.2	18.7	24.3	29.9	
72	THC	43.3	43.3	43.3	41.0	41.0	41.0	38.3	38.3	38.3	35.2	35.2	35.2		
	SHC	17.2	22.8	28.4	16.4	22.0	27.7	15.3	21.0	26.6	14.2	19.8	25.4		
76	THC	-	45.8	45.8	-	44.0	44.0	-	41.6	41.6	-	38.6	38.6		
	SHC	-	18.4	24.2	-	17.8	23.5	-	16.9	22.7	-	15.9	21.6		
1200 Cfm	EAT (wb)	58	THC	35.7	35.7	40.5	33.5	33.5	38.1	31.3	31.3	35.6	28.9	28.9	32.9
		SHC	30.8	35.7	40.5	28.9	33.5	38.1	27.0	31.3	35.6	24.9	28.9	32.9	
	62	THC	36.3	36.3	41.5	33.6	33.6	39.7	31.3	31.3	37.1	29.0	29.0	34.3	
		SHC	28.9	35.2	41.5	27.4	33.6	39.7	25.6	31.3	37.1	23.6	29.0	34.3	
	67	THC	40.4	40.4	40.4	37.8	37.8	37.8	34.7	34.7	34.7	31.4	31.4	32.6	
		SHC	23.6	30.0	36.4	22.5	28.9	35.3	21.3	27.6	34.0	19.9	26.3	32.6	
72	THC	44.1	44.1	44.1	42.0	42.0	42.0	39.2	39.2	39.2	36.0	36.0	36.0		
	SHC	17.7	23.9	30.2	16.9	23.3	29.6	15.9	22.3	28.6	14.7	21.1	27.5		
76	THC	-	46.6	46.6	-	44.4	44.4	-	42.3	42.3	-	39.4	39.4		
	SHC	-	19.0	25.5	-	18.3	24.7	-	17.6	24.0	-	16.6	23.1		
1350 Cfm	EAT (wb)	58	THC	37.5	37.5	42.6	35.1	35.1	40.0	32.8	32.8	37.3	30.3	30.3	34.5
		SHC	32.4	37.5	42.6	30.3	35.1	40.0	28.3	32.8	37.3	26.1	30.3	34.5	
	62	THC	37.6	37.6	44.4	35.2	35.2	41.6	32.8	32.8	38.8	30.3	30.3	35.9	
		SHC	30.7	37.6	44.4	28.8	35.2	41.6	26.8	32.8	38.8	24.8	30.3	35.9	
	67	THC	41.2	41.2	41.2	38.6	38.6	38.6	35.6	35.6	36.7	32.2	32.2	35.3	
		SHC	24.8	31.9	39	23.7	30.8	38.0	22.5	29.6	36.7	21.1	28.2	35.3	
72	THC	44.7	44.7	44.7	42.7	42.7	42.7	39.9	39.9	39.9	36.7	36.7	36.7		
	SHC	18.0	24.9	31.8	17.3	24.4	31.5	16.3	23.5	30.6	15.2	22.3	29.5		
76	THC	-	47.2	47.2	-	44.9	44.9	-	42.9	42.9	-	39.9	39.9		
	SHC	-	19.5	26.6	-	18.7	25.7	-	18.1	25.2	-	17.2	24.4		
1500 Cfm	EAT (wb)	58	THC	38.8	38.8	44.1	36.6	36.6	41.6	34.1	34.1	38.8	31.5	31.5	35.8
		SHC	33.5	38.8	44.1	31.6	36.6	41.6	29.4	34.1	38.8	27.2	31.5	35.8	
	62	THC	38.8	38.8	45.9	36.6	36.6	43.3	34.1	34.1	40.4	31.6	31.6	37.3	
		SHC	31.7	38.8	45.9	29.9	36.6	43.3	27.9	34.1	40.4	25.8	31.6	37.3	
	67	THC	41.8	41.8	41.8	39.2	39.2	40.6	36.3	36.3	39.3	32.8	32.8	37.9	
		SHC	25.8	33.6	41.4	24.9	32.7	40.6	23.7	31.5	39.3	22.3	30.1	37.9	
72	THC	45.2	45.2	45.2	43.2	43.2	43.2	40.5	40.5	40.5	37.2	37.2	37.2		
	SHC	18.4	25.8	33.3	17.7	25.4	33.2	16.8	24.6	32.5	15.6	23.5	31.4		
76	THC	-	47.6	47.6	-	45.2	45.2	-	43.2	43.2	-	40.3	40.3		
	SHC	-	19.9	27.5	-	19.1	26.7	-	18.6	26.3	-	17.7	25.6		

50TCQ

LEGEND

- Do not operate in this region (Points are outside SST and SDT permissible operating range)
- Cfm - Cubic feet per minute (supply air)
- EAT(db) - Entering air temperature (dry bulb)
- EAT(wb) - Entering air temperature (wet bulb)
- SHC - Sensible heat capacity
- THC - Total capacity

Table 28 – COOLING CAPACITIES

1-STAGE COOLING

4 TONS

50TCQ

50TCQA05			AMBIENT TEMPERATURE												
			85			95			105			115			
			EAT (db)			EAT (db)			EAT (db)			EAT (db)			
			75	80	85	75	80	85	75	80	85	75	80	85	
1200 Cfm	EAT (wb)	58	THC	41.7	41.7	46.9	39.9	39.9	45.1	37.8	37.8	43.1	35.6	35.6	41.0
		SHC	36.5	41.7	46.9	34.7	39.9	45.1	32.5	37.8	43.1	30.3	35.6	41.0	
		62	THC	44.1	44.1	44.1	42.0	42.0	43.1	39.4	39.4	41.9	36.7	36.7	40.6
		SHC	33.7	38.9	44.1	32.6	37.8	43.1	31.3	36.6	41.9	29.8	35.2	40.6	
		67	THC	48.8	48.8	48.8	46.4	46.4	46.4	43.7	43.7	43.7	40.9	40.9	40.9
	SHC	28.2	33.4	38.6	27.1	32.4	37.6	25.9	31.3	36.6	24.6	30.0	35.4		
	72	THC	53.2	53.2	53.2	50.7	50.7	50.7	48.1	48.1	48.1	45.2	45.2	45.2	
	SHC	22.3	27.5	32.7	21.3	26.5	31.8	20.2	25.5	30.8	18.9	24.4	29.8		
	76	THC	-	56.2	56.2	-	53.8	53.8	-	51.1	51.1	-	48.0	48.0	
	SHC	-	22.5	27.7	-	21.7	27.0	-	20.8	26.1	-	19.7	25.1		
1400 Cfm	EAT (wb)	58	THC	44.1	44.1	50.2	42.2	42.2	48.3	40.2	40.2	46.4	38.0	38.0	44.3
		SHC	38.1	44.1	50.2	36.1	42.2	48.3	34.0	40.2	46.4	31.7	38.0	44.3	
		62	THC	45.8	45.8	48.3	43.3	43.3	47.1	40.8	40.8	45.8	38.0	38.0	44.3
		SHC	36.2	42.3	48.3	34.9	41.0	47.1	33.4	39.6	45.8	31.7	38.0	44.3	
		67	THC	50.2	50.2	50.2	47.7	47.7	47.7	44.9	44.9	44.9	42.0	42.0	42.0
	SHC	29.7	35.8	41.9	28.7	34.8	40.9	27.5	33.7	39.9	26.2	32.5	38.8		
	72	THC	54.4	54.4	54.4	52.0	52.0	52.0	49.2	49.2	49.2	46.2	46.2	46.2	
	SHC	22.9	28.9	35.0	21.9	28.0	34.1	20.8	27.0	33.2	19.5	25.8	32.2		
	76	THC	-	57.1	57.1	-	54.8	54.8	-	52.0	52.0	-	48.7	48.7	
	SHC	-	23.3	29.4	-	22.5	28.6	-	21.5	27.7	-	20.3	26.7		
1600 Cfm	EAT (wb)	58	THC	46.1	46.1	53.1	44.0	44.0	51.0	41.9	41.9	48.9	39.6	39.6	46.8
		SHC	39.2	46.1	53.1	37.1	44.0	51.0	34.8	41.9	48.9	32.4	39.6	46.8	
		62	THC	46.9	46.9	52.1	44.6	44.6	50.5	42.0	42.0	49.0	39.6	39.6	46.8
		SHC	38.2	45.2	52.1	36.5	43.5	50.5	34.9	42.0	49.0	32.4	39.6	46.8	
		67	THC	51.2	51.2	51.2	48.7	48.7	48.7	45.9	45.9	45.9	42.8	42.8	42.8
	SHC	31.1	38.0	45.0	30.1	37.1	44.0	28.9	35.9	43.0	27.5	34.7	42.0		
	72	THC	55.3	55.3	55.3	52.9	52.9	52.9	50.0	50.0	50.0	46.9	46.9	46.9	
	SHC	23.2	30.1	37.1	22.3	29.3	36.3	21.2	28.3	35.4	19.9	27.1	34.4		
	76	THC	-	57.8	57.8	-	55.4	55.4	-	52.6	52.6	-	49.3	49.3	
	SHC	-	23.9	30.8	-	23.1	30.1	-	22.1	29.2	-	20.9	28.2		
1800 Cfm	EAT (wb)	58	THC	47.7	47.7	55.5	45.6	45.6	53.5	43.4	43.4	51.3	41.0	41.0	49.1
		SHC	39.9	47.7	55.5	37.8	45.6	53.5	35.4	43.4	51.3	32.8	41.0	49.1	
		62	THC	47.9	47.9	55.7	45.7	45.7	53.5	43.4	43.4	51.4	41.0	41.0	49.1
		SHC	40.1	47.9	55.7	37.8	45.7	53.5	35.5	43.4	51.4	32.9	41.0	49.1	
		67	THC	52.0	52.0	52.0	49.4	49.4	49.4	46.6	46.6	46.6	43.5	43.5	45.0
	SHC	32.3	40.1	47.9	31.3	39.2	47.1	30.1	38.1	46.0	28.7	36.9	45.0		
	72	THC	55.9	55.9	55.9	53.5	53.5	53.5	50.6	50.6	50.6	47.4	47.4	47.4	
	SHC	23.4	31.3	39.1	22.6	30.5	38.3	21.5	29.5	37.4	20.1	28.3	36.4		
	76	THC	-	58.3	58.3	-	55.9	55.9	-	53.1	53.1	-	49.6	49.6	
	SHC	-	24.4	32.2	-	23.6	31.5	-	22.6	30.6	-	21.4	29.6		
2000 Cfm	EAT (wb)	58	THC	49.1	49.1	57.7	46.9	46.9	55.7	44.6	44.6	53.5	42.1	42.1	51.1
		SHC	40.4	49.1	57.7	38.2	46.9	55.7	35.8	44.6	53.5	33.1	42.1	51.1	
		62	THC	49.1	49.1	57.7	47.0	47.0	55.7	44.7	44.7	53.5	42.2	42.2	51.2
		SHC	40.4	49.1	57.7	38.2	47.0	55.7	35.8	44.7	53.5	33.1	42.2	51.2	
		67	THC	52.6	52.6	52.6	50.0	50.0	50.0	47.1	47.1	49.0	44.0	44.0	47.9
	SHC	33.4	42.0	50.7	32.5	41.2	49.9	31.2	40.1	49.0	29.8	38.8	47.9		
	72	THC	56.4	56.4	56.4	53.9	53.9	53.9	51.1	51.1	51.1	47.8	47.8	47.8	
	SHC	23.6	32.2	40.9	22.8	31.5	40.3	21.7	30.6	39.4	20.3	29.3	38.4		
	76	THC	-	58.6	58.6	-	56.3	56.3	-	53.4	53.4	-	49.9	49.9	
	SHC	-	24.8	33.5	-	24.0	32.8	-	23.1	32.0	-	21.8	30.9		

LEGEND

- Do not operate in this region (Points are outside SST and SDT permissible operating range)
- Cfm - Cubic feet per minute (supply air)
- EAT(db) - Entering air temperature (dry bulb)
- EAT(wb) - Entering air temperature (wet bulb)
- SHC - Sensible heat capacity
- THC - Total capacity

Table 29 – COOLING CAPACITIES

1-STAGE COOLING

5 TONS

50TCQA06			AMBIENT TEMPERATURE												
			85			95			105			115			
			EAT (db)			EAT (db)			EAT (db)			EAT (db)			
			75	80	85	75	80	85	75	80	85	75	80	85	
1500 Cfm	EAT (wb)	58	THC	52.7	52.7	59.2	49.9	49.9	56.5	46.9	46.9	53.6	43.6	43.6	50.4
			SHC	46.2	52.7	59.2	43.4	49.9	56.5	40.3	46.9	53.6	36.8	43.6	50.4
		62	THC	55.5	55.5	55.8	52.1	52.1	54.3	48.1	48.1	52.4	43.7	43.7	50.3
			SHC	42.8	49.3	55.8	41.1	47.7	54.3	39.2	45.8	52.4	36.7	43.5	50.3
		67	THC	61.7	61.7	61.7	58.1	58.1	58.1	54.1	54.1	54.1	49.6	49.6	49.6
		SHC	35.6	42.1	48.6	34.0	40.5	47.1	32.2	38.8	45.5	30.2	37.0	43.8	
	72	THC	68.0	68.0	68.0	64.3	64.3	64.3	60.1	60.1	60.1	55.5	55.5	55.5	
		SHC	27.9	34.4	40.9	26.4	33.0	39.6	24.7	31.4	38.1	22.8	29.7	36.5	
		76	THC	-	72.9	72.9	-	69.0	69.0	-	64.5	64.5	-	59.5	59.5
			SHC	-	28.0	34.5	-	26.6	33.2	-	25.1	31.8	-	23.4	30.2
1750 Cfm	EAT (wb)	58	THC	56.0	56.0	63.6	53.0	53.0	60.7	49.9	49.9	57.7	46.5	46.5	54.5
			SHC	48.4	56.0	63.6	45.4	53.0	60.7	42.2	49.9	57.7	38.6	46.5	54.5
		62	THC	57.6	57.6	61.6	54.1	54.1	59.9	50.1	50.1	57.6	46.6	46.6	54.5
			SHC	46.4	54.0	61.6	44.6	52.2	59.9	42.1	49.8	57.6	38.7	46.6	54.5
		67	THC	63.6	63.6	63.6	59.9	59.9	59.9	55.7	55.7	55.7	51.1	51.1	51.1
		SHC	38.0	45.6	53.2	36.4	44.0	51.7	34.5	42.3	50.1	32.5	40.5	48.4	
	72	THC	69.9	69.9	69.9	66.0	66.0	66.0	61.7	61.7	61.7	56.9	56.9	56.9	
		SHC	29.0	36.6	44.2	27.5	35.2	42.8	25.7	33.5	41.3	23.7	31.7	39.7	
		76	THC	-	74.6	74.6	-	70.6	70.6	-	65.8	65.8	-	60.5	60.5
			SHC	-	29.2	36.8	-	27.8	35.5	-	26.1	34.0	-	24.3	32.3
2000 Cfm	EAT (wb)	58	THC	58.8	58.8	67.4	55.8	55.8	64.5	52.5	52.5	61.4	48.8	48.8	57.9
			SHC	50.1	58.8	67.4	47.0	55.8	64.5	43.6	52.5	61.4	39.7	48.8	57.9
		62	THC	59.3	59.3	66.9	55.9	55.9	64.6	52.5	52.5	61.4	48.8	48.8	57.9
			SHC	49.5	58.2	66.9	47.1	55.9	64.6	43.6	52.5	61.4	39.8	48.8	57.9
		67	THC	65.1	65.1	65.1	61.3	61.3	61.3	56.9	56.9	56.9	52.2	52.2	52.8
		SHC	40.2	48.9	57.6	38.6	47.3	56.1	36.7	45.6	54.5	34.6	43.7	52.8	
	72	THC	71.3	71.3	71.3	67.3	67.3	67.3	62.8	62.8	62.8	57.8	57.8	57.8	
		SHC	29.9	38.6	47.3	28.3	37.1	45.9	26.5	35.5	44.4	24.5	33.6	42.7	
		76	THC	-	75.9	75.9	-	71.7	71.7	-	66.6	66.6	-	61.2	61.2
			SHC	-	30.2	38.9	-	28.7	37.6	-	27.0	36.0	-	25.1	34.3
2250 Cfm	EAT (wb)	58	THC	61.0	61.0	70.8	57.9	57.9	67.8	54.5	54.5	64.5	50.7	50.7	60.9
			SHC	51.3	61.0	70.8	48.1	57.9	67.8	44.5	54.5	64.5	40.5	50.7	60.9
		62	THC	61.1	61.1	70.8	58.0	58.0	67.8	54.6	54.6	64.6	50.7	50.7	61.0
			SHC	51.3	61.1	70.8	48.1	58.0	67.8	44.6	54.6	64.6	40.5	50.7	61.0
		67	THC	66.2	66.2	66.2	62.3	62.3	62.3	57.9	57.9	58.8	53.1	53.1	57.0
		SHC	42.3	52.0	61.8	40.6	50.5	60.4	38.7	48.7	58.8	36.6	46.8	57.0	
	72	THC	72.3	72.3	72.3	68.3	68.3	68.3	63.7	63.7	63.7	58.5	58.5	58.5	
		SHC	30.6	40.4	50.2	29.1	39.0	48.9	27.2	37.3	47.3	25.0	35.3	45.5	
		76	THC	-	76.9	76.9	-	72.5	72.5	-	67.4	67.4	-	61.8	61.8
			SHC	-	31.1	40.9	-	29.6	39.5	-	27.9	37.9	-	25.9	36.2
2500 Cfm	EAT (wb)	58	THC	63.0	63.0	73.8	59.8	59.8	70.7	56.2	56.2	67.3	52.3	52.3	63.7
			SHC	52.1	63.0	73.8	48.8	59.8	70.7	45.1	56.2	67.3	41.0	52.3	63.7
		62	THC	63.0	63.0	73.9	59.8	59.8	70.8	56.3	56.3	67.4	52.4	52.4	63.7
			SHC	52.2	63.0	73.9	48.9	59.8	70.8	45.2	56.3	67.4	41.0	52.4	63.7
		67	THC	67.2	67.2	67.2	63.1	63.1	64.5	58.7	58.7	62.8	53.8	53.8	61.0
		SHC	44.2	55.0	65.9	42.5	53.5	64.5	40.6	51.7	62.8	38.3	49.6	61.0	
	72	THC	73.2	73.2	73.2	69.0	69.0	69.0	64.3	64.3	64.3	59.0	59.0	59.0	
		SHC	31.3	42.2	53.1	29.7	40.7	51.7	27.8	38.9	50.1	25.5	36.9	48.3	
		76	THC	-	77.7	77.7	-	73.1	73.1	-	67.9	67.9	-	62.2	62.2
			SHC	-	32.0	42.9	-	30.5	41.5	-	28.6	39.8	-	26.6	38.0

50TCQ

LEGEND

- Do not operate in this region (Points are outside SST and SDT permissible operating range)
- Cfm - Cubic feet per minute (supply air)
- EAT(db) - Entering air temperature (dry bulb)
- EAT(wb) - Entering air temperature (wet bulb)
- SHC - Sensible heat capacity
- THC - Total capacity

Table 30 – COOLING CAPACITIES

1-STAGE COOLING

6 TONS

50TCQ

50TCQA07			AMBIENT TEMPERATURE												
			85			95			105			115			
			EAT (db)			EAT (db)			EAT (db)			EAT (db)			
			75	80	85	75	80	85	75	80	85	75	80	85	
1800 Cfm	EAT (wb)	58	THC	61.1	61.1	68.9	58.3	58.3	66.1	55.2	55.2	63.2	51.8	51.8	59.9
		SHC	53.3	61.1	68.9	50.4	58.3	66.1	47.2	55.2	63.2	43.7	51.8	59.9	
		62	THC	64.1	64.1	65.2	60.5	60.5	63.6	56.5	56.5	61.8	52.1	52.1	59.7
		SHC	49.6	57.4	65.2	47.8	55.7	63.6	45.8	53.8	61.8	43.4	51.6	59.7	
		67	THC	70.8	70.8	70.8	67.2	67.2	67.2	63.1	63.1	63.1	58.6	58.6	58.6
	SHC	40.7	48.5	56.3	39.1	47.0	54.9	37.3	45.3	53.3	35.3	43.5	51.7		
	72	THC	77.4	77.4	77.4	73.7	73.7	73.7	69.5	69.5	69.5	64.9	64.9	64.9	
	SHC	31.1	38.9	46.7	29.6	37.5	45.5	27.9	36.0	44.0	26.0	34.2	42.5		
	76	THC	-	82.0	82.0	-	78.4	78.4	-	73.9	73.9	-	68.8	68.8	
	SHC	-	30.9	38.8	-	29.7	37.6	-	28.1	36.2	-	26.4	34.6		
2100 Cfm	EAT (wb)	58	THC	64.6	64.6	73.7	61.6	61.6	70.8	58.4	58.4	67.7	54.8	54.8	64.3
		SHC	55.5	64.6	73.7	52.5	61.6	70.8	49.1	58.4	67.7	45.3	54.8	64.3	
		62	THC	66.1	66.1	71.7	62.5	62.5	69.9	58.5	58.5	67.8	54.9	54.9	64.4
		SHC	53.4	62.5	71.7	51.5	60.7	69.9	49.2	58.5	67.8	45.3	54.9	64.4	
		67	THC	72.8	72.8	72.8	69.0	69.0	69.0	64.8	64.8	64.8	60.2	60.2	60.2
	SHC	43.1	52.2	61.3	41.5	50.7	59.9	39.7	49.1	58.4	37.7	47.3	56.8		
	72	THC	79.2	79.2	79.2	75.4	75.4	75.4	71.0	71.0	71.0	66.2	66.2	66.2	
	SHC	31.9	41.1	50.2	30.5	39.7	49.0	28.7	38.1	47.5	26.7	36.3	45.9		
	76	THC	-	83.1	83.1	-	79.8	79.8	-	75.1	75.1	-	69.7	69.7	
	SHC	-	32.0	41.2	-	30.7	39.9	-	29.1	38.5	-	27.3	36.9		
2400 Cfm	EAT (wb)	58	THC	67.4	67.4	77.8	64.4	64.4	74.9	61.0	61.0	71.7	57.3	57.3	68.2
		SHC	57.0	67.4	77.8	53.9	64.4	74.9	50.3	61.0	71.7	46.4	57.3	68.2	
		62	THC	67.8	67.8	77.4	64.4	64.4	74.9	61.0	61.0	71.7	57.3	57.3	68.3
		SHC	56.5	66.9	77.4	53.9	64.4	74.9	50.3	61.0	71.7	46.4	57.3	68.3	
		67	THC	74.3	74.3	74.3	70.4	70.4	70.4	66.1	66.1	66.1	61.4	61.4	61.7
	SHC	45.3	55.7	66.1	43.7	54.2	64.7	41.9	52.6	63.3	39.9	50.8	61.7		
	72	THC	80.4	80.4	80.4	76.6	76.6	76.6	72.1	72.1	72.1	67.1	67.1	67.1	
	SHC	32.6	43.0	53.4	31.2	41.7	52.3	29.3	40.1	50.8	27.2	38.2	49.2		
	76	THC	-	84.0	84.0	-	80.7	80.7	-	76.0	76.0	-	70.4	70.4	
	SHC	-	32.6	43.1	-	31.6	42.2	-	30.0	40.8	-	28.1	39.1		
2700 Cfm	EAT (wb)	58	THC	69.7	69.7	81.5	66.6	66.6	78.5	63.1	63.1	75.2	59.3	59.3	71.6
		SHC	58.0	69.7	81.5	54.8	66.6	78.5	51.1	63.1	75.2	47.0	59.3	71.6	
		62	THC	69.8	69.8	81.5	66.6	66.6	78.4	63.2	63.2	75.2	59.4	59.4	71.7
		SHC	58.0	69.8	81.5	54.8	66.6	78.4	51.2	63.2	75.2	47.1	59.4	71.7	
		67	THC	75.4	75.4	75.4	71.4	71.4	71.4	67.1	67.1	67.9	62.3	62.3	66.4
	SHC	47.2	59.0	70.7	45.7	57.6	69.4	43.9	55.9	67.9	41.8	54.1	66.4		
	72	THC	81.3	81.3	81.3	77.5	77.5	77.5	72.9	72.9	72.9	67.8	67.8	67.8	
	SHC	33.0	44.8	56.5	31.7	43.6	55.5	29.8	41.9	54.0	27.7	40.0	52.4		
	76	THC	-	84.9	84.9	-	81.3	81.3	-	76.6	76.6	-	70.8	70.8	
	SHC	-	33.4	45.2	-	33.0	44.9	-	30.8	43.0	-	28.8	41.3		
3000 Cfm	EAT (wb)	58	THC	71.7	71.7	84.7	68.5	68.5	81.7	64.9	64.9	78.3	61.0	61.0	74.7
		SHC	58.7	71.7	84.7	55.4	68.5	81.7	51.6	64.9	78.3	47.3	61.0	74.7	
		62	THC	71.7	71.7	84.8	68.6	68.6	81.7	65.0	65.0	78.3	61.0	61.0	74.7
		SHC	58.7	71.7	84.8	55.4	68.6	81.7	51.6	65.0	78.3	47.4	61.0	74.7	
		67	THC	76.4	76.4	76.4	72.3	72.3	73.8	67.9	67.9	72.4	63.0	63.0	70.8
	SHC	49.0	62.1	75.1	47.5	60.7	73.8	45.7	59	72.4	43.4	57.1	70.8		
	72	THC	82.0	82.0	82.0	78.2	78.2	78.2	73.5	73.5	73.5	68.2	68.2	68.2	
	SHC	33.4	46.5	59.5	32.1	45.3	58.5	30.2	43.6	57.1	28.0	41.7	55.5		
	76	THC	-	85.5	85.5	-	81.8	81.8	-	77.1	77.1	-	71.3	71.3	
	SHC	-	34.2	47.2	-	33.0	46.3	-	31.6	45.1	-	29.5	43.3		

LEGEND

- Do not operate in this region (Points are outside SST and SDT permissible operating range)
- Cfm - Cubic feet per minute (supply air)
- EAT(db) - Entering air temperature (dry bulb)
- EAT(wb) - Entering air temperature (wet bulb)
- SHC - Sensible heat capacity
- THC - Total capacity

Table 31 – COOLING CAPACITIES

2-STAGE COOLING

7.5 TONS

50TCQD08			AMBIENT TEMPERATURE												
			85			95			105			115			
			EAT (db)			EAT (db)			EAT (db)			EAT (db)			
			75	80	85	75	80	85	75	80	85	75	80	85	
2250 Cfm	EAT (wb)	58	THC	77.4	77.4	87.8	74.1	74.1	84.1	69.8	69.8	79.2	65.2	65.2	74.1
			SHC	66.9	77.4	87.8	64.0	74.1	84.1	60.3	69.8	79.2	56.4	65.2	74.1
		62	THC	81.8	81.8	83.7	77.2	77.2	81.4	71.9	71.9	78.9	66.6	66.6	75.9
			SHC	60.6	72.1	83.7	58.4	69.9	81.4	55.9	67.4	78.9	53.2	64.5	75.9
		67	THC	90.6	90.6	90.6	86.0	86.0	86.0	80.8	80.8	80.8	75.1	75.1	75.1
			SHC	50.4	62.0	73.5	48.4	60.0	71.6	46.2	57.8	69.3	43.9	55.4	67.0
		72	THC	99.4	99.4	99.4	94.7	94.7	94.7	89.5	89.5	89.5	83.8	83.8	83.8
			SHC	39.6	51.3	62.9	37.7	49.4	61.0	35.8	47.4	59.0	33.6	45.2	56.8
		76	THC	-	105.7	105.7	-	100.8	100.8	-	95.5	95.5	-	89.7	89.7
			SHC	-	42.1	54.5	-	40.4	52.8	-	38.6	50.9	-	36.5	48.8
2625 Cfm	EAT (wb)	58	THC	81.8	81.8	92.8	78.0	78.0	88.6	74.1	74.1	84.2	69.5	69.5	78.9
			SHC	70.7	81.8	92.8	67.5	78.0	88.6	64.1	74.1	84.2	60.1	69.5	78.9
		62	THC	84.7	84.7	91.7	79.9	79.9	89.2	75.2	75.2	86.2	69.8	69.8	81.6
			SHC	65.2	78.5	91.7	62.9	76.1	89.2	60.3	73.3	86.2	56.8	69.2	81.6
		67	THC	93.4	93.4	93.4	88.6	88.6	88.6	83.2	83.2	83.2	77.4	77.4	77.4
			SHC	53.4	66.7	80.1	51.4	64.7	78.1	49.2	62.5	75.9	46.8	60.2	73.5
		72	THC	101.9	101.9	101.9	97.1	97.1	97.1	91.8	91.8	91.8	86.0	86.0	86.0
			SHC	40.8	54.1	67.5	38.9	52.3	65.6	36.9	50.3	63.6	34.8	48.1	61.5
		76	THC	-	107.7	107.7	-	102.6	102.6	-	97.2	97.2	-	91.2	91.2
			SHC	-	43.7	58.1	-	41.9	56.0	-	39.9	53.9	-	37.9	51.6
3000 Cfm	EAT (wb)	58	THC	85.6	85.6	97.2	81.8	81.8	92.9	77.6	77.6	88.0	72.9	72.9	82.8
			SHC	74.1	85.6	97.2	70.7	81.8	92.9	67.1	77.6	88.0	63.0	72.9	82.8
		62	THC	87.0	87.0	98.9	82.5	82.5	95.4	78.0	78.0	90.5	73.3	73.3	85.6
			SHC	69.4	84.1	98.9	66.6	81.0	95.4	63.1	76.8	90.5	59.6	72.6	85.6
		67	THC	95.5	95.5	95.5	90.5	90.5	90.5	85.1	85.1	85.1	79.0	79.0	79.6
			SHC	56.1	71.2	86.2	54.1	69.2	84.2	51.9	67.0	82.1	49.5	64.6	79.6
		72	THC	103.8	103.8	103.8	98.8	98.8	98.8	93.4	93.4	93.4	87.5	87.5	87.5
			SHC	41.8	56.7	71.6	39.9	54.8	69.8	37.9	52.9	67.8	35.8	50.7	65.7
		76	THC	-	109.1	109.1	-	104.0	104.0	-	98.3	98.3	-	92.2	92.2
			SHC	-	44.9	60.6	-	43.1	58.6	-	41.1	56.4	-	39.0	54.2
3375 Cfm	EAT (wb)	58	THC	88.9	88.9	100.9	84.9	84.9	96.4	80.5	80.5	91.4	75.7	75.7	86.0
			SHC	76.9	88.9	100.9	73.4	84.9	96.4	69.6	80.5	91.4	65.5	75.7	86.0
		62	THC	89.6	89.6	103.8	85.1	85.1	100.4	81.0	81.0	94.1	75.8	75.8	89.5
			SHC	72.4	88.1	103.8	69.7	85.0	100.4	65.6	79.8	94.1	62.1	75.8	89.5
		67	THC	97.1	97.1	97.1	92.1	92.1	92.1	86.5	86.5	87.9	80.3	80.3	85.4
			SHC	58.7	75.3	92.0	56.7	73.4	90.1	54.5	71.2	87.9	52.0	68.7	85.4
		72	THC	105.2	105.2	105.2	100.0	100.0	100.0	94.5	94.5	94.5	88.5	88.5	88.5
			SHC	42.6	59.0	75.3	40.7	57.1	73.5	38.8	55.2	71.6	36.6	53.1	69.5
		76	THC	-	110.1	110.1	-	105.0	105.0	-	99.2	99.2	-	92.9	92.9
			SHC	-	45.9	62.8	-	44.1	60.9	-	42.1	58.7	-	40.0	56.4
3750 Cfm	EAT (wb)	58	THC	91.6	91.6	104.0	87.5	87.5	99.4	83.0	83.0	94.3	78.1	78.1	88.7
			SHC	79.2	91.6	104.0	75.7	87.5	99.4	71.8	83.0	94.3	67.6	78.1	88.7
		62	THC	91.7	91.7	108.3	87.7	87.7	103.5	83.1	83.1	98.1	78.2	78.2	92.3
			SHC	75.2	91.7	108.3	71.8	87.7	103.5	68.1	83.1	98.1	64.1	78.2	92.3
		67	THC	98.4	98.4	98.4	93.3	93.3	95.6	87.7	87.7	93.4	81.5	81.5	90.9
			SHC	61.1	79.3	97.5	59.1	77.3	95.6	56.9	75.2	93.4	54.5	72.7	90.9
		72	THC	106.2	106.2	106.2	101.0	101.0	101.0	95.4	95.4	95.4	89.3	89.3	89.3
			SHC	43.4	61.1	78.8	41.5	59.2	76.9	39.5	57.3	75.0	37.4	55.2	73.0
		76	THC	-	111.0	111.0	-	105.8	105.8	-	99.8	99.8	-	93.5	93.5
			SHC	-	46.8	64.9	-	45.1	63.1	-	43.0	60.8	-	40.9	58.4

50TCQ

LEGEND

- Do not operate in this region (Points are outside SST and SDT permissible operating range)
- Cfm - Cubic feet per minute (supply air)
- EAT(db) - Entering air temperature (dry bulb)
- EAT(wb) - Entering air temperature (wet bulb)
- SHC - Sensible heat capacity
- THC - Total capacity

Table 32 – COOLING CAPACITIES

2-STAGE COOLING

8.5 TONS

50TCQ

50TCQD09			AMBIENT TEMPERATURE												
			85			95			105			115			
			EAT (db)			EAT (db)			EAT (db)			EAT (db)			
			75	80	85	75	80	85	75	80	85	75	80	85	
2550 Cfm	EAT (wb)	58	THC	91.1	91.1	102.9	86.4	86.4	97.5	81.2	81.2	91.7	75.7	75.7	85.5
		SHC	79.4	91.1	102.9	75.2	86.4	97.5	70.8	81.2	91.7	66.0	75.7	85.5	
		62	THC	96.0	96.0	99.4	89.2	89.2	96.4	83.0	83.0	93.4	76.5	76.5	88.0
		SHC	72.7	86.0	99.4	69.6	83.0	96.4	66.7	80.0	93.4	62.4	75.2	88.0	
		67	THC	106.4	106.4	106.4	100.4	100.4	100.4	92.9	92.9	92.9	86.0	86.0	86.0
	SHC	60.4	73.8	87.2	57.7	71.1	84.5	54.7	68.1	81.6	51.8	65.2	78.6		
	72	THC	117.3	117.3	117.3	111.2	111.2	111.2	104.3	104.3	104.3	97.0	97.0	97.0	
	SHC	47.4	60.9	74.4	45.1	58.5	72.0	42.4	55.9	69.4	39.7	53.1	66.6		
	76	THC	-	126.1	126.1	-	119.9	119.9	-	113.0	113.0	-	105.6	105.6	
	SHC	-	50.3	64.3	-	48.0	61.8	-	45.6	59.4	-	43.0	56.7		
2975 Cfm	EAT (wb)	58	THC	96.5	96.5	109.0	91.7	91.7	103.5	86.7	86.7	97.9	80.5	80.5	90.9
		SHC	84.1	96.5	109.0	79.9	91.7	103.5	75.5	86.7	97.9	70.1	80.5	90.9	
		62	THC	98.2	98.2	109.0	92.9	92.9	105.4	87.0	87.0	100.5	80.6	80.6	94.5
		SHC	78.1	93.6	109.0	75.1	90.2	105.4	71.3	85.9	100.5	66.7	80.6	94.5	
		67	THC	109.5	109.5	109.5	103.0	103.0	103.0	96.3	96.3	96.3	87.6	87.6	87.6
	SHC	64.1	79.6	95.2	61.4	76.9	92.5	58.7	74.3	89.8	55.3	70.9	86.5		
	72	THC	120.6	120.6	120.6	114.2	114.2	114.2	107.3	107.3	107.3	99.5	99.5	99.5	
	SHC	49.1	64.7	80.3	46.7	62.3	77.9	44.1	59.7	75.3	41.3	56.9	72.5		
	76	THC	-	129.2	129.2	-	122.9	122.9	-	115.7	115.7	-	108.1	108.1	
	SHC	-	52.3	68.4	-	50.0	65.8	-	47.6	63.5	-	45.0	60.8		
3400 Cfm	EAT (wb)	58	THC	101.0	101.0	114.0	96.7	96.7	109.1	90.9	90.9	102.6	84.9	84.9	95.8
		SHC	88.0	101.0	114.0	84.2	96.7	109.1	79.2	90.9	102.6	74.0	84.9	95.8	
		62	THC	102.3	102.3	116.5	96.9	96.9	112.5	90.7	90.7	106.3	84.6	84.6	99.1
		SHC	82.9	99.7	116.5	79.7	96.1	112.5	75.1	90.7	106.3	70.0	84.6	99.1	
		67	THC	112.1	112.1	112.1	105.5	105.5	105.5	98.4	98.4	98.4	90.8	90.8	94.2
	SHC	67.7	85.3	102.9	65.1	82.7	100.2	62.2	79.8	97.3	59.2	76.7	94.2		
	72	THC	123.0	123.0	123.0	116.5	116.5	116.5	109.4	109.4	109.4	101.6	101.6	101.6	
	SHC	50.5	68.2	85.9	48.2	65.8	83.5	45.6	63.2	80.8	42.8	60.4	78.1		
	76	THC	-	131.5	131.5	-	124.9	124.9	-	117.7	117.7	-	109.9	109.9	
	SHC	-	54.1	72.1	-	51.8	69.7	-	49.4	67.2	-	46.8	64.6		
3825 Cfm	EAT (wb)	58	THC	104.5	104.5	118.0	99.8	99.8	112.6	94.4	94.4	106.6	87.9	87.9	99.2
		SHC	91.1	104.5	118.0	86.9	99.8	112.6	82.3	94.4	106.6	76.6	87.9	99.2	
		62	THC	105.0	105.0	123.0	100.3	100.3	117.5	93.4	93.4	109.5	87.3	87.3	102.3
		SHC	86.9	105.0	123.0	83.0	100.3	117.5	77.4	93.4	109.5	72.3	87.3	102.3	
		67	THC	114.1	114.1	114.1	107.4	107.4	107.6	99.4	99.4	104.6	92.0	92.0	101.3
	SHC	71.2	90.8	110.4	68.5	88.1	107.6	65.4	85.0	104.6	62.4	81.9	101.3		
	72	THC	124.9	124.9	124.9	118.2	118.2	118.2	111.0	111.0	111.0	103.1	103.1	103.1	
	SHC	51.9	71.5	91.1	49.5	69.1	88.7	47.0	66.6	86.2	44.2	63.8	83.4		
	76	THC	-	133.3	133.3	-	126.5	126.5	-	119.2	119.2	-	111.2	111.2	
	SHC	-	55.7	75.6	-	53.5	73.3	-	51.1	70.8	-	48.5	68.1		
4250 Cfm	EAT (wb)	58	THC	108.6	108.6	122.6	102.7	102.7	115.9	97.4	97.4	110.0	90.8	90.8	102.5
		SHC	94.6	108.6	122.6	89.5	102.7	115.9	84.9	97.4	110.0	79.1	90.8	102.5	
		62	THC	109.0	109.0	126.4	103.4	103.4	121.2	97.5	97.5	114.2	91.3	91.3	106.9
		SHC	89.5	107.9	126.4	85.6	103.4	121.2	80.7	97.5	114.2	75.6	91.3	106.9	
		67	THC	115.6	115.6	117.4	108.9	108.9	114.7	101.6	101.6	111.4	93.6	93.6	108.1
	SHC	74.3	95.9	117.4	71.7	93.2	114.7	68.7	90.1	111.4	65.6	86.8	108.1		
	72	THC	126.4	126.4	126.4	119.7	119.7	119.7	112.3	112.3	112.3	104.2	104.2	104.2	
	SHC	53.1	74.6	96.1	50.8	72.3	93.8	48.2	69.8	91.4	45.4	67.0	88.5		
	76	THC	-	134.6	134.6	-	127.8	127.8	-	120.3	120.3	-	112.3	112.3	
	SHC	-	57.2	78.8	-	55.0	76.6	-	52.6	74.1	-	50.0	71.5		

LEGEND

- Do not operate in this region (Points are outside SST and SDT permissible operating range)
- Cfm - Cubic feet per minute (supply air)
- EAT(db) - Entering air temperature (dry bulb)
- EAT(wb) - Entering air temperature (wet bulb)
- SHC - Sensible heat capacity
- THC - Total capacity

Table 33 – COOLING CAPACITIES

2-STAGE COOLING

10 TONS

50TCQD12			AMBIENT TEMPERATURE												
			85			95			105			115			
			EAT (db)			EAT (db)			EAT (db)			EAT (db)			
			75	80	85	75	80	85	75	80	85	75	80	85	
3000 Cfm	EAT (wb)	58	THC	102.8	102.8	121.0	96.3	96.3	115.8	90.1	90.1	109.5	83.5	83.5	102.9
			SHC	82.1	101.5	121.0	76.8	96.3	115.8	70.6	90.1	109.5	64.0	83.5	102.9
		62	THC	108.0	108.0	114.3	100.4	100.4	111.1	92.1	92.1	107.1	84.2	84.2	102.0
			SHC	75.4	94.9	114.3	72.2	91.7	111.1	68.1	87.6	107.1	63.1	82.5	102.0
		67	THC	120.5	120.5	120.5	113.5	113.5	113.5	104.9	104.9	104.9	95.2	95.2	95.2
		SHC	60.2	79.7	99.2	57.7	77.2	96.7	54.4	73.9	93.4	50.8	70.3	89.7	
		72	THC	132.8	132.8	132.8	126.5	126.5	126.5	118.6	118.6	118.6	109.3	109.3	109.3
		SHC	44.5	64.0	83.4	42.2	61.7	81.2	39.5	59.0	78.5	36.4	55.9	75.3	
		76	THC	-	142.0	142.0	-	136.0	136.0	-	129.1	129.1	-	120.3	120.3
		SHC	-	50.9	70.4	-	48.8	68.2	-	46.6	66.0	-	43.7	63.2	
3500 Cfm	EAT (wb)	58	THC	108.2	108.2	130.9	102.5	102.5	125.2	95.5	95.5	118.2	88.3	88.3	111.0
			SHC	85.5	108.2	130.9	79.8	102.5	125.2	72.8	95.5	118.2	65.6	88.3	111.0
		62	THC	111.4	111.4	125.8	104.6	104.6	122.1	96.3	96.3	117.0	88.7	88.7	110.7
			SHC	80.4	103.1	125.8	76.7	99.4	122.1	71.6	94.3	117.0	65.3	88.0	110.7
		67	THC	123.4	123.4	123.4	116.3	116.3	116.3	107.9	107.9	107.9	97.5	97.5	98.9
		SHC	62.6	85.3	108.0	60.1	82.9	105.6	57.2	79.9	102.6	53.5	76.2	98.9	
		72	THC	135.4	135.4	135.4	129.2	129.2	129.2	121.2	121.2	121.2	112.0	112.0	112.0
		SHC	44.2	67.0	89.7	42.2	64.9	87.6	39.5	62.2	85.0	36.5	59.3	82.0	
		76	THC	-	144.6	144.6	-	138.4	138.4	-	131.3	131.3	-	-	-
		SHC	-	51.9	74.6	-	50.0	72.7	-	47.8	70.5	-	-	-	
4000 Cfm	EAT (wb)	58	THC	112.7	112.7	138.7	106.9	106.9	132.9	99.9	99.9	125.9	92.3	92.3	118.2
			SHC	86.7	112.7	138.7	81.0	106.9	132.9	74.0	99.9	125.9	66.3	92.3	118.2
		62	THC	114.0	114.0	135.3	107.6	107.6	131.3	100.4	100.4	125.5	92.3	92.3	118.3
			SHC	83.4	109.3	135.3	79.3	105.3	131.3	73.6	99.6	125.5	66.4	92.3	118.3
		67	THC	125.4	125.4	125.4	118.2	118.2	118.2	109.5	109.5	111.2	99.1	99.1	107.7
		SHC	64.5	90.5	116.4	62.2	88.1	114.1	59.3	85.3	111.2	55.8	81.8	107.7	
		72	THC	137.2	137.2	137.2	130.7	130.7	130.7	122.8	122.8	122.8	113.5	113.5	113.5
		SHC	43.6	69.6	95.5	41.7	67.6	93.6	39.2	65.1	91.1	36.3	62.2	88.2	
		76	THC	-	146.3	146.3	-	139.9	139.9	-	132.5	132.5	-	-	-
		SHC	-	52.8	78.7	-	50.8	76.8	-	48.6	74.6	-	-	-	
4500 Cfm	EAT (wb)	58	THC	115.9	115.9	145.2	110.4	110.4	139.6	103.4	103.4	132.6	95.4	95.4	124.6
			SHC	86.7	115.9	145.2	81.2	110.4	139.6	74.2	103.4	132.6	66.2	95.4	124.6
		62	THC	116.6	116.6	143.2	110.4	110.4	139.4	103.9	103.9	131.8	95.4	95.4	124.6
			SHC	84.8	114.0	143.2	81.0	110.2	139.4	73.4	102.6	131.8	66.2	95.4	124.6
		67	THC	126.5	126.5	126.5	119.5	119.5	122.2	110.6	110.6	119.6	100.2	100.2	116.1
		SHC	65.9	95.1	124.3	63.8	93.0	122.2	61.2	90.4	119.6	57.7	86.9	116.1	
		72	THC	138.0	138.0	138.0	131.5	131.5	131.5	123.9	123.9	123.9	114.2	114.2	114.2
		SHC	42.7	71.9	101.1	40.8	70.0	99.2	38.5	67.7	96.9	35.6	64.8	94.0	
		76	THC	-	147.3	147.3	-	140.6	140.6	-	-	-	-	-	-
		SHC	-	53.3	82.6	-	51.4	80.6	-	-	-	-	-	-	
5000 Cfm	EAT (wb)	58	THC	118.4	118.4	150.9	112.9	112.9	145.4	105.9	105.9	138.4	97.8	97.8	130.2
			SHC	86.0	118.4	150.9	80.5	112.9	145.4	73.5	105.9	138.4	65.3	97.8	130.2
		62	THC	118.5	118.5	150.7	113.5	113.5	144.5	106.0	106.0	138.4	97.9	97.9	130.3
			SHC	85.8	118.3	150.7	79.6	112.0	144.5	73.5	106.0	138.4	65.4	97.9	130.3
		67	THC	126.9	126.9	131.8	120.0	120.0	130.0	111.1	111.1	127.4	100.8	100.8	123.9
		SHC	66.9	99.4	131.8	65.1	97.5	130.0	62.5	94.9	127.4	59.0	91.4	123.9	
		72	THC	138.4	138.4	138.4	131.6	131.6	131.6	124.0	124.0	124.0	114.2	114.2	114.2
		SHC	41.4	73.8	106.3	39.5	71.9	104.4	37.3	69.8	102.2	34.6	67.0	99.5	
		76	THC	-	147.7	147.7	-	140.9	140.9	-	-	-	-	-	-
		SHC	-	53.6	86.1	-	51.7	84.2	-	-	-	-	-	-	

50TCQ

LEGEND

- Do not operate in this region (Points are outside SST and SDT permissible operating range)
- Cfm - Cubic feet per minute (supply air)
- EAT(db) - Entering air temperature (dry bulb)
- EAT(wb) - Entering air temperature (wet bulb)
- SHC - Sensible heat capacity
- THC - Total capacity

Table 34 – COOLING CAPACITIES

2-STAGE COOLING

12.5 TONS

50TCQ

50TCQD14			AMBIENT TEMPERATURE												
			85			95			105			115			
			EAT (DB)			EAT (DB)			EAT (DB)			EAT (DB)			
			75	80	85	75	80	85	75	80	85	75	80	85	
3750 Cfm	EAT (wb)	58	THC	126.4	126.4	143.6	119.1	119.1	135.3	111.8	111.8	127.0	104.0	104.0	118.2
			SHC	109.2	126.4	143.6	102.9	119.1	135.3	96.5	111.8	127.0	89.8	104.0	118.2
		62	THC	134.5	134.5	138.4	124.7	124.7	133.4	114.9	114.9	128.1	105.8	105.8	120.8
			SHC	100.3	119.4	138.4	95.5	114.4	133.4	90.5	109.3	128.1	84.6	102.7	120.8
		67	THC	149.6	149.6	149.6	140.5	140.5	140.5	130.0	130.0	130.0	118.8	118.8	118.8
		SHC	83.5	102.5	121.4	79.8	98.9	118.1	75.4	94.6	113.7	70.8	89.9	109.1	
	72	THC	161.4	161.4	161.4	155.2	155.2	155.2	146.4	146.4	146.4	135.7	135.7	135.7	
		SHC	64.5	83.5	102.5	62.1	81.2	100.4	58.8	78.1	97.3	54.8	74.1	93.3	
		76	THC	-	169.5	169.5	-	163.1	163.1	-	156.8	156.8	-	147.7	147.7
			SHC	-	68.1	88.7	-	65.7	86.2	-	63.4	83.7	-	60.3	80.3
4375 Cfm	EAT (wb)	58	THC	134.6	134.6	152.9	126.8	126.8	144.1	118.8	118.8	135.0	110.5	110.5	125.6
			SHC	116.3	134.6	152.9	109.6	126.8	144.1	102.7	118.8	135.0	95.5	110.5	125.6
		62	THC	139.9	139.9	151.3	130.0	130.0	145.7	120.7	120.7	138.1	111.2	111.2	130.1
			SHC	107.9	129.6	151.3	102.8	124.2	145.7	96.7	117.4	138.1	90.4	110.3	130.1
		67	THC	153.7	153.7	153.7	145.2	145.2	145.2	134.5	134.5	134.5	122.9	122.9	122.9
		SHC	87.9	109.4	131.0	84.8	106.8	128.8	80.6	102.6	124.7	75.8	97.9	120.0	
	72	THC	164.6	164.6	164.6	158.2	158.2	158.2	150.5	150.5	150.5	139.9	139.9	139.9	
		SHC	66.0	87.2	108.5	63.6	85.1	106.5	60.9	82.8	104.8	57.0	79.1	101.2	
		76	THC	-	172.4	172.4	-	165.7	165.7	-	159.3	159.3	-	150.8	150.8
			SHC	-	70.2	93.5	-	67.8	91.0	-	65.7	88.8	-	62.8	85.8
5000 Cfm	EAT (wb)	58	THC	141.4	141.4	160.6	133.5	133.5	151.6	125.0	125.0	142.0	116.2	116.2	132.0
			SHC	122.1	141.4	160.6	115.3	133.5	151.6	108.0	125.0	142.0	100.4	116.2	132.0
		62	THC	144.4	144.4	162.1	135.4	135.4	155.1	125.9	125.9	147.1	116.4	116.4	137.6
			SHC	114.3	138.2	162.1	108.5	131.8	155.1	102.2	124.6	147.1	95.3	116.4	137.6
		67	THC	156.6	156.6	156.6	148.8	148.8	148.8	138.1	138.1	138.1	126.3	126.3	130.2
		SHC	91.7	115.6	139.5	89.3	113.9	138.6	85.3	110.2	135.0	80.6	105.4	130.2	
	72	THC	167.0	167.0	167.0	160.5	160.5	160.5	153.3	153.3	153.3	142.9	142.9	142.9	
		SHC	67.3	90.6	113.9	64.9	88.6	112.2	62.5	87.0	111.4	58.9	83.7	108.5	
		76	THC	-	174.6	174.6	-	167.5	167.5	-	160.7	160.7	-	152.9	152.9
			SHC	-	72.2	98.1	-	69.8	95.6	-	67.4	92.9	-	64.8	90.2
5625 Cfm	EAT (wb)	58	THC	146.6	146.6	166.6	139.0	139.0	157.9	130.3	130.3	148.1	121.2	121.2	137.7
			SHC	126.6	146.6	166.6	120.0	139.0	157.9	112.6	130.3	148.1	104.7	121.2	137.7
		62	THC	148.4	148.4	169.8	139.9	139.9	163.3	130.5	130.5	154.3	121.3	121.3	143.4
			SHC	118.8	144.3	169.8	113.5	138.4	163.3	106.8	130.5	154.3	99.2	121.3	143.4
		67	THC	158.8	158.8	158.8	151.5	151.5	151.5	140.9	140.9	144.6	129.1	129.1	140.0
		SHC	95.1	121.2	147.3	93.3	120.4	147.4	89.6	117.1	144.6	85.0	112.5	140.0	
	72	THC	168.9	168.9	168.9	162.1	162.1	162.1	155.3	155.3	155.3	145.1	145.1	145.1	
		SHC	68.4	93.7	118.9	66.1	91.7	117.3	63.9	90.6	117.3	60.6	87.9	115.2	
		76	THC	-	176.2	176.2	-	168.9	168.9	-	161.7	161.7	-	154.3	154.3
			SHC	-	73.9	101.8	-	71.3	98.8	-	68.8	96.1	-	66.6	94.1
6250 Cfm	EAT (wb)	58	THC	150.6	150.6	171.1	143.5	143.5	163.1	134.9	134.9	153.3	125.5	125.5	142.6
			SHC	130.0	150.6	171.1	123.9	143.5	163.1	116.5	134.9	153.3	108.4	125.5	142.6
		62	THC	151.4	151.4	176.1	143.7	143.7	169.9	135.1	135.1	159.7	125.6	125.6	148.5
			SHC	122.6	149.3	176.1	117.6	143.7	169.9	110.5	135.1	159.7	102.7	125.6	148.5
		67	THC	160.4	160.4	160.4	153.4	153.4	155.3	143.2	143.2	153.4	131.3	131.3	148.7
		SHC	98.2	126.4	154.5	96.8	126.0	155.3	93.6	123.5	153.4	88.9	118.8	148.7	
	72	THC	170.3	170.3	170.3	163.4	163.4	163.4	156.7	156.7	156.7	146.8	146.8	146.8	
		SHC	69.5	96.5	123.5	67.1	94.5	121.9	65.1	93.8	122.5	62.0	91.7	121.3	
		76	THC	-	177.5	177.5	-	170.1	170.1	-	162.7	162.7	-	155.4	155.4
			SHC	-	75.2	104.7	-	72.6	101.8	-	70.2	99.2	-	68.2	97.7

LEGEND

- Do not operate in this region (Points are outside SST and SDT permissible operating range)
- Cfm - Cubic feet per minute (supply air)
- EAT(db) - Entering air temperature (dry bulb)
- EAT(wb) - Entering air temperature (wet bulb)
- SHC - Sensible heat capacity
- THC - Total capacity

Table 35 – HEATING CAPACITIES

3 TONS

50TCQA04											
RETURN AIR (°F db)	CFM (STANDARD AIR)		TEMPERATURE AIR ENTERING OUTDOOR COIL (°F db AT 70% RH)								
			-10	0	10	17	30	40	47	50	60
55	900	Capacity	11.6	15.1	18.9	21.7	27.6	32.7	36.0	37.1	41.8
		Int. Cap.	10.7	13.9	17.4	19.8	24.2	32.7	36.0	37.1	41.8
	1200	Capacity	12.0	15.5	19.4	22.3	28.4	33.5	36.7	37.8	42.7
		Int. Cap.	11.1	14.3	17.8	20.3	24.9	33.5	36.7	37.8	42.7
	1500	Capacity	12.6	16.3	20.2	23.1	29.5	34.2	37.5	38.6	43.5
		Int. Cap.	11.6	15.0	18.5	21.1	25.8	34.2	37.5	38.6	43.5
70	900	Capacity	9.8	13.3	17.2	20.0	25.6	30.4	34.5	35.5	40.2
		Int. Cap.	9.0	12.3	15.7	18.2	22.5	30.4	34.5	35.5	40.2
	1200	Capacity	10.1	13.8	17.7	20.7	26.6	31.7	35.4	36.5	41.2
		Int. Cap.	9.3	12.7	16.3	18.8	23.3	31.7	35.4	36.5	41.2
	1500	Capacity	10.8	14.6	18.6	21.5	27.7	33.0	36.4	37.4	42.0
		Int. Cap.	10.0	13.4	17.1	19.6	24.3	33.0	36.4	37.4	42.0
80	900	Capacity	8.3	11.9	15.7	18.6	24.1	29.0	32.7	34.1	39.0
		Int. Cap.	7.7	10.9	14.4	16.9	21.2	29.0	32.7	34.1	39.0
	1200	Capacity	8.6	12.4	16.3	19.3	25.1	30.2	34.3	35.4	40.1
		Int. Cap.	8.0	11.4	15.0	17.6	22.0	30.2	34.3	35.4	40.1
	1500	Capacity	9.3	13.2	17.2	20.2	26.2	31.4	35.5	36.5	41.1
		Int. Cap.	8.6	12.1	15.8	18.4	23.0	31.4	35.5	36.5	41.1

50TCQ

LEGEND

- Capacity – Instantaneous Capacity (1000 Btu/h) includes indoor fan motor heat @AHRI static conditions
- Int. Cap. – Integrated Capacity is Instantaneous Capacity minus the effects of frost on the outdoor coil and the heat required to defrost
- RH – Relative Humidity
- db – Dry Bulb

Table 36 – HEATING CAPACITIES

4 TONS

50TCQA05											
RETURN AIR (°F db)	CFM (STANDARD AIR)		TEMPERATURE AIR ENTERING OUTDOOR COIL (°F db AT 70% RH)								
			-10	0	10	17	30	40	47	50	60
55	1200	Capacity	17.5	22.0	26.6	30.0	36.8	42.6	47.1	48.9	55.3
		Int. Cap.	16.2	20.2	24.4	27.3	32.2	42.6	47.1	48.9	55.3
	1600	Capacity	17.5	22.1	26.7	30.2	37.3	43.5	47.9	49.8	56.1
		Int. Cap.	16.2	20.3	24.5	27.5	32.7	43.5	47.9	49.8	56.1
	2000	Capacity	18.5	23.1	27.8	31.3	38.7	44.9	49.1	50.9	57.1
		Int. Cap.	17.1	21.3	25.5	28.6	33.9	44.9	49.1	50.9	57.1
70	1200	Capacity	15.8	20.3	25.0	28.3	35.0	40.5	44.7	46.7	53.0
		Int. Cap.	14.6	18.7	22.9	25.8	30.6	40.5	44.7	46.7	53.0
	1600	Capacity	15.9	20.5	25.3	28.7	35.6	41.3	45.8	47.8	53.9
		Int. Cap.	14.7	18.9	23.2	26.1	31.2	41.3	45.8	47.8	53.9
	2000	Capacity	17.0	21.7	26.5	29.9	36.9	42.9	47.3	49.1	55.2
		Int. Cap.	15.7	20.0	24.3	27.3	32.4	42.9	47.3	49.1	55.2
80	1200	Capacity	14.2	18.8	23.5	26.9	33.6	39.0	43.2	45.1	51.4
		Int. Cap.	13.1	17.3	21.6	24.6	29.4	39.0	43.2	45.1	51.4
	1600	Capacity	14.4	19.1	23.9	27.4	34.2	39.8	44.2	46.1	52.4
		Int. Cap.	13.3	17.6	22.0	25.0	30.0	39.8	44.2	46.1	52.4
	2000	Capacity	15.5	20.3	25.2	28.7	35.6	41.4	45.9	47.8	53.8
		Int. Cap.	14.3	18.7	23.1	26.1	31.2	41.4	45.9	47.8	53.8

LEGEND

- Capacity – Instantaneous Capacity (1000 Btu/h) includes indoor fan motor heat @AHRI static conditions
- Int. Cap. – Integrated Capacity is Instantaneous Capacity minus the effects of frost on the outdoor coil and the heat required to defrost
- RH – Relative Humidity
- db – Dry Bulb

Table 37 – HEATING CAPACITY

5 TONS

50TCQ06											
RETURN AIR (°F db)	CFM (STANDARD AIR)		TEMPERATURE AIR ENTERING OUTDOOR COIL (°F db AT 70% RH)								
			-10	0	10	17	30	40	47	50	60
55	1500	Capacity	22.7	28.3	34.2	38.6	47.4	54.3	60.0	62.6	70.3
		Int. Cap.	21.0	26.1	31.4	35.2	41.5	54.3	60.0	62.6	70.3
	2000	Capacity	22.8	28.5	34.4	38.9	47.9	55.3	60.9	63.1	70.9
		Int. Cap.	21.1	26.2	31.6	35.4	42.0	55.3	60.9	63.1	70.9
	2500	Capacity	24.2	30.0	35.9	40.4	49.6	56.9	62.3	64.4	72.0
		Int. Cap.	22.4	27.6	33.0	36.8	43.5	56.9	62.3	64.4	72.0
70	1500	Capacity	19.9	25.8	31.9	36.3	45.2	51.7	57.6	60.0	67.9
		Int. Cap.	18.4	23.7	29.3	33.1	39.6	51.7	57.6	60.0	67.9
	2000	Capacity	20.1	26.1	32.3	36.7	45.8	52.9	58.4	61.0	68.8
		Int. Cap.	18.6	24.0	29.6	33.5	40.1	52.9	58.4	61.0	68.8
	2500	Capacity	21.5	27.6	33.8	38.3	47.5	54.7	60.4	62.7	70.2
		Int. Cap.	19.9	25.4	31.1	35.0	41.6	54.7	60.4	62.7	70.2
80	1500	Capacity	17.6	23.7	30.0	34.6	43.5	50.2	55.7	58.2	66.1
		Int. Cap.	16.3	21.9	27.6	31.5	38.1	50.2	55.7	58.2	66.1
	2000	Capacity	17.8	24.1	30.5	35.1	44.3	51.2	56.6	59.4	67.2
		Int. Cap.	16.5	22.2	28.0	32.0	38.8	51.2	56.6	59.4	67.2
	2500	Capacity	19.3	25.6	32.1	36.8	46.0	53.1	58.8	61.1	68.8
		Int. Cap.	17.8	23.6	29.4	33.5	40.3	53.1	58.8	61.1	68.8

LEGEND

- Capacity – Instantaneous Capacity (1000 Btuh) includes indoor fan motor heat @AHRI static conditions
- Int. Cap. – Integrated Capacity is Instantaneous Capacity minus the effects of frost on the outdoor coil and the heat required to defrost
- RH – Relative Humidity
- db – Dry Bulb

Table 38 – HEATING CAPACITY

6 TONS

50TCQ07											
RETURN AIR (°F db)	CFM (STANDARD AIR)		TEMPERATURE AIR ENTERING OUTDOOR COIL (°F db AT 70% RH)								
			-10	0	10	17	30	40	47	50	60
55	1800	Capacity	22.4	29.8	37.1	42.5	53.5	62.4	68.6	71.2	80.3
		Int. Cap.	20.7	27.4	34.1	38.8	46.9	62.4	68.6	71.2	80.3
	2400	Capacity	24.6	32.1	39.6	45.1	56.4	65.6	71.5	74.2	83.8
		Int. Cap.	22.7	29.5	36.3	41.1	49.4	65.6	71.5	74.2	83.8
	3000	Capacity	27.4	35.0	42.5	48.2	59.5	68.6	74.5	77.2	86.8
		Int. Cap.	25.3	32.2	39.0	43.9	52.1	68.6	74.5	77.2	86.8
70	1800	Capacity	17.7	25.5	33.2	38.6	49.5	58.5	65.0	67.7	76.5
		Int. Cap.	16.4	23.5	30.5	35.2	43.4	58.5	65.0	67.7	76.5
	2400	Capacity	19.9	27.9	35.8	41.4	52.7	62.0	68.4	71.0	80.3
		Int. Cap.	18.4	25.7	32.9	37.7	46.2	62.0	68.4	71.0	80.3
	3000	Capacity	22.8	30.9	38.9	44.5	56.1	65.5	71.7	74.4	83.9
		Int. Cap.	21.1	28.4	35.7	40.6	49.2	65.5	71.7	74.4	83.9
80	1800	Capacity	13.9	21.9	29.9	35.5	46.2	55.3	62.0	64.9	73.7
		Int. Cap.	12.8	20.2	27.4	32.3	40.5	55.3	62.0	64.9	73.7
	2400	Capacity	16.0	24.4	32.6	38.4	49.6	59.0	65.8	68.6	77.5
		Int. Cap.	14.8	22.5	29.9	35.0	43.5	59.0	65.8	68.6	77.5
	3000	Capacity	18.8	27.4	35.8	41.6	53.1	62.7	69.4	72.1	81.4
		Int. Cap.	17.4	25.2	32.8	37.9	46.6	62.7	69.4	72.1	81.4

LEGEND

- Capacity – Instantaneous Capacity (1000 Btuh) includes indoor fan motor heat @AHRI static conditions
- Int. Cap. – Integrated Capacity is Instantaneous Capacity minus the effects of frost on the outdoor coil and the heat required to defrost
- RH – Relative Humidity
- db – Dry Bulb

Table 39 – HEATING CAPACITY

7.5 TONS

50TCQD08											
RETURN AIR (°F db)	CFM (STANDARD AIR)		TEMPERATURE AIR ENTERING OUTDOOR COIL (°F db AT 70% RH)								
			-10	0	10	17	30	40	47	50	60
55	2250	Capacity	[Hatched]		46.9	53.5	66.3	77.2	86.2	89.4	103.3
		Int. Cap.			43.1	48.7	58.1	77.2	86.2	89.4	103.3
	3000	Capacity	[Hatched]				68.5	80.2	89.8	93.1	106.7
		Int. Cap.					60.0	80.2	89.8	93.1	106.7
	3750	Capacity	[Hatched]			58.9	72.5	84.6	94.5	97.6	110.6
		Int. Cap.				53.7	63.5	84.6	94.5	97.6	110.6
70	2250	Capacity	25.9	34.6	43.6	50.2	62.7	73.0	81.4	84.5	98.0
		Int. Cap.	23.9	31.8	40.0	45.7	55.0	73.0	81.4	84.5	98.0
	3000	Capacity	27.4	36.2	45.5	52.2	65.1	75.9	85.0	88.2	102.1
		Int. Cap.	25.3	33.4	41.8	47.6	57.0	75.9	85.0	88.2	102.1
	3750	Capacity	31.0	40.0	49.3	56.1	69.1	80.4	89.8	93.2	106.5
		Int. Cap.	28.6	36.8	45.3	51.1	60.6	80.4	89.8	93.2	106.5
80	2250	Capacity	22.5	31.5	40.7	47.3	60.1	70.3	78.2	81.2	94.3
		Int. Cap.	20.8	29.0	37.3	43.1	52.6	70.3	78.2	81.2	94.3
	3000	Capacity	24.1	33.3	42.7	49.5	62.5	73.1	81.6	84.7	98.6
		Int. Cap.	22.3	30.6	39.2	45.2	54.8	73.1	81.6	84.7	98.6
	3750	Capacity	27.8	37.1	46.6	53.5	66.7	77.5	86.4	89.7	103.4
		Int. Cap.	25.7	34.1	42.8	48.8	58.4	77.5	86.4	89.7	103.4

[Hatched] – Indicates operation not permissible

LEGEND

- Capacity – Instantaneous Capacity (1000 Btuh) includes indoor fan motor heat @AHRI static conditions
- Int. Cap. – Integrated Capacity is Instantaneous Capacity minus the effects of frost on the outdoor coil and the heat required to defrost
- RH – Relative Humidity
- db – Dry Bulb

Table 40 – HEATING CAPACITY

8.5 TONS

50TCQD09											
RETURN AIR (°F db)	CFM (STANDARD AIR)		TEMPERATURE AIR ENTERING OUTDOOR COIL (°F db AT 70% RH)								
			-10	0	10	17	30	40	47	50	60
55	2550	Capacity	33.1	42.7	52.7	60.0	75.6	87.4	97.5	100.6	113.8
		Int. Cap.	30.7	39.3	48.3	54.7	66.2	87.4	97.5	100.6	113.8
	3400	Capacity	34.4	44.0	54.2	61.8	77.5	89.9	100.2	103.1	115.7
		Int. Cap.	31.8	40.5	49.8	56.4	67.9	89.9	100.2	103.1	115.7
	4250	Capacity	38.0	47.7	58.0	65.8	81.5	94.2	103.9	106.6	118.2
		Int. Cap.	35.2	43.9	53.2	60.0	71.4	94.2	103.9	106.6	118.2
70	2550	Capacity	29.0	38.6	48.6	55.9	70.7	83.5	93.1	96.2	109.5
		Int. Cap.	26.8	35.5	44.6	51.0	61.9	83.5	93.1	96.2	109.5
	3400	Capacity	30.3	40.2	50.4	58.0	73.5	86.1	96.5	99.2	111.9
		Int. Cap.	28.0	37.0	46.3	52.9	64.4	86.1	96.5	99.2	111.9
	4250	Capacity	34.0	44.0	54.4	62.1	77.8	90.5	100.5	103.3	115.2
		Int. Cap.	31.5	40.5	50.0	56.6	68.2	90.5	100.5	103.3	115.2
80	2550	Capacity	25.3	35.0	45.2	52.6	67.1	80.0	90.0	93.2	106.5
		Int. Cap.	23.4	32.2	41.5	48.0	58.8	80.0	90.0	93.2	106.5
	3400	Capacity	26.6	36.7	47.2	54.8	69.8	83.0	93.1	96.2	109.2
		Int. Cap.	24.6	33.8	43.3	50.0	61.2	83.0	93.1	96.2	109.2
	4250	Capacity	30.4	40.6	51.2	59.0	74.4	87.7	97.7	100.7	112.8
		Int. Cap.	28.1	37.4	47.0	53.8	65.1	87.7	97.7	100.7	112.8

LEGEND

- Capacity – Instantaneous Capacity (1000 Btuh) includes indoor fan motor heat @AHRI static conditions
- Int. Cap. – Integrated Capacity is Instantaneous Capacity minus the effects of frost on the outdoor coil and the heat required to defrost
- RH – Relative Humidity
- db – Dry Bulb

50TCQ

Table 41 – HEATING CAPACITY

10 TONS

50TCQD12											
RETURN AIR (°F db)	CFM (STANDARD AIR)		TEMPERATURE AIR ENTERING OUTDOOR COIL (°F db AT 70% RH)								
			-10	0	10	17	30	40	47	50	60
55	3000	Capacity	41.8	52.4	64.1	72.8	90.4	105.3	118.0	121.9	140.3
		Int. Cap.	38.7	48.2	58.8	66.3	79.2	105.3	118.0	121.9	140.3
	4000	Capacity	43.3	54.0	66.0	74.5	92.7	107.8	120.2	124.1	142.1
		Int. Cap.	40.0	49.7	60.6	68.0	81.2	107.8	120.2	124.1	142.1
	5000	Capacity	46.9	57.7	69.7	78.2	96.6	111.5	123.5	127.3	142.3
		Int. Cap.	43.3	53.1	64.0	71.3	84.6	111.5	123.5	127.3	142.3
70	3000	Capacity	37.4	48.2	59.7	68.5	86.2	100.6	113.0	117.1	135.3
		Int. Cap.	34.6	44.4	54.8	62.4	75.5	100.6	113.0	117.1	135.3
	4000	Capacity	39.0	49.9	61.6	70.7	88.5	103.3	115.9	119.8	137.6
		Int. Cap.	36.1	45.9	56.6	64.5	77.5	103.3	115.9	119.8	137.6
	5000	Capacity	42.6	53.7	65.5	74.8	92.5	107.5	119.6	123.4	140.6
		Int. Cap.	39.4	49.4	60.1	68.2	81.1	107.5	119.6	123.4	140.6
80	3000	Capacity	33.9	44.8	56.5	65.1	83.2	97.3	109.5	113.4	131.6
		Int. Cap.	31.4	41.3	51.8	59.3	72.9	97.3	109.5	113.4	131.6
	4000	Capacity	35.5	46.6	58.5	67.3	85.5	100.0	112.5	116.5	134.2
		Int. Cap.	32.8	42.9	53.7	61.4	75.0	100.0	112.5	116.5	134.2
	5000	Capacity	39.1	50.4	62.3	71.3	89.6	104.3	116.6	120.4	137.5
		Int. Cap.	36.2	46.4	57.2	65.0	78.5	104.3	116.6	120.4	137.5

50TCQ

LEGEND

- Capacity – Instantaneous Capacity (1000 Btuh) includes indoor fan motor heat @AHRI static conditions
- Int. Cap. – Integrated Capacity is Instantaneous Capacity minus the effects of frost on the outdoor coil and the heat required to defrost
- RH – Relative Humidity
- db – Dry Bulb

Table 42 – HEATING CAPACITY

12.5 TONS

50TCQD14											
RETURN AIR (°F dB)	CFM (STANDARD AIR)		TEMPERATURE AIR ENTERING OUTDOOR COIL (°F db AT 70% RH)								
			-10	0	10	17	30	40	47	50	60
55	3750	Capacity	33.7	47.5	69.8	83.1	109.3	131.7	149.7	155.6	180.1
		Int. Cap.	31.2	43.7	64.0	75.8	95.8	131.7	149.7	155.6	180.1
	5000	Capacity	35.7	49.7	72.4	85.8	112.9	136.1	152.9	158.1	178.7
		Int. Cap.	33.0	45.7	66.5	78.2	99.0	136.1	152.9	158.1	178.7
	6250	Capacity	38.9	53.0	76.2	89.5	117.1	139.4	153.5	158.0	175.6
		Int. Cap.	36.0	48.8	70.0	81.6	102.6	139.4	153.5	158.0	175.6
70	3750	Capacity	24.4	38.2	59.4	73.1	99.8	121.2	138.5	144.5	169.7
		Int. Cap.	22.6	35.2	54.5	66.7	87.4	121.2	138.5	144.5	169.7
	5000	Capacity	26.4	40.4	62.1	76.6	103.2	125.4	143.0	148.6	170.3
		Int. Cap.	24.4	37.2	57.0	69.8	90.4	125.4	143.0	148.6	170.3
	6250	Capacity	29.6	43.8	65.9	80.7	107.3	129.8	145.5	150.4	169.1
		Int. Cap.	27.3	40.3	60.5	73.6	94.0	129.8	145.5	150.4	169.1
80	3750	Capacity	17.5	31.4	52.6	65.6	93.3	114.2	131.1	137.0	162.4
		Int. Cap.	16.2	28.9	48.3	59.8	81.8	114.2	131.1	137.0	162.4
	5000	Capacity	19.3	33.4	55.2	68.7	96.6	118.2	135.7	141.5	164.0
		Int. Cap.	17.8	30.8	50.7	62.6	84.6	118.2	135.7	141.5	164.0
	6250	Capacity	22.4	40.3	58.8	72.7	100.6	122.6	139.3	144.3	163.8
		Int. Cap.	20.7	37.1	54.0	66.3	88.2	122.6	139.3	144.3	163.8

LEGEND

- Capacity – Instantaneous Capacity (1000 Btuh) includes indoor fan motor heat @AHRI static conditions
- Int. Cap. – Integrated Capacity is Instantaneous Capacity minus the effects of frost on the outdoor coil and the heat required to defrost
- RH – Relative Humidity
- db – Dry Bulb

Table 43 – STATIC PRESSURE ADDERS (FACTORY OPTIONS AND/OR ACCESSORIES)

Economizer

3 – 6 TONS											
CFM (in. wg)	600	800	1000	1250	1500	1750	2000	2250	2500	2750	3000
Vertical Econo- mizer	0.01	0.02	0.04	0.05	0.07	0.09	0.12	0.15	0.18	0.22	0.26
Horizontal Economizer	0.02	0.03	0.04	0.06	0.08	0.10	0.13	0.15	0.18	0.23	0.28

7.5 – 12.5 TONS																
CFM (in. wg)	2250	2500	2750	3000	3250	3500	3750	4000	4250	4500	4750	5000	5250	5500	5750	6000
Vertical Econo- mizer	0.06	0.08	0.09	0.12	0.13	0.15	0.17	0.20	0.22	0.25	0.29	0.33	0.36	0.40	0.44	0.48
Horizontal Economizer	0.08	0.10	0.13	0.15	0.18	0.21	0.25	0.28	0.30	0.34	0.39	0.43	0.47	0.51	0.56	0.60

Electric Heaters

3 – 6 TONS										
CFM (in. wg)	600	900	1200	1400	1600	1800	2000	2200	2400	2600
1 Electric Heater Module	0.03	0.05	0.07	0.09	0.09	0.10	0.11	0.11	0.12	0.13
2 Electric Heater Modules	0.13	0.15	0.16	0.16	0.16	0.17	0.17	0.17	0.18	0.18

7.5 – 10 TONS																
CFM (in. wg)	2250	2500	2750	3000	3250	3500	3750	4000	4250	4500	4750	5000	5250	5500	5750	6000
1 Electric Heater Module	0.03	0.04	0.04	0.05	0.06	0.07	0.08	0.09	0.10	0.11	0.12	0.13	0.14	0.15	0.16	0.18
2 Electric Heater Modules	0.04	0.05	0.05	0.06	0.07	0.08	0.09	0.10	0.11	0.12	0.13	0.15	0.16	0.17	0.19	0.20

12.5 TONS													
CFM (in. wg)	2813	3125	3438	3750	4063	4375	4688	5000	5313	5625	5938	6250	
Vertical – 1 Electric Heater Module	0.01	0.01	0.02	0.02	0.02	0.02	0.02	0.03	0.03	0.03	0.03	0.04	
Vertical – 2 Electric Heater Modules	0.02	0.03	0.03	0.03	0.04	0.04	0.05	0.05	0.06	0.06	0.07	0.08	
Horizontal – 1 Electric Heater Module	0.03	0.03	0.04	0.04	0.05	0.05	0.06	0.06	0.07	0.07	0.08	0.09	
Horizontal – 2 Electric Heater Modules	0.02	0.03	0.03	0.04	0.04	0.04	0.05	0.05	0.06	0.06	0.07	0.08	

50TCQ

ECONOMIZER, BAROMETRIC RELIEF AND PE PERFORMANCE

50TCQ

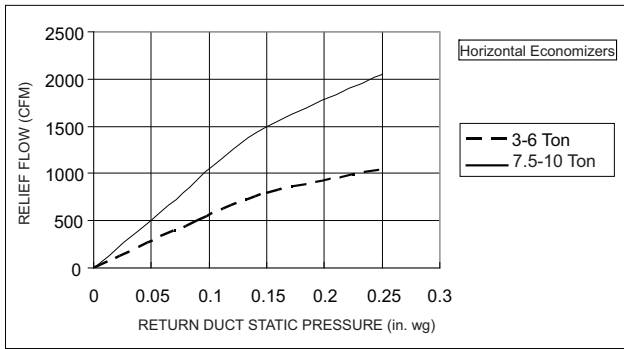

C09879

Fig. 16 - Barometric Relief Flow Capacity

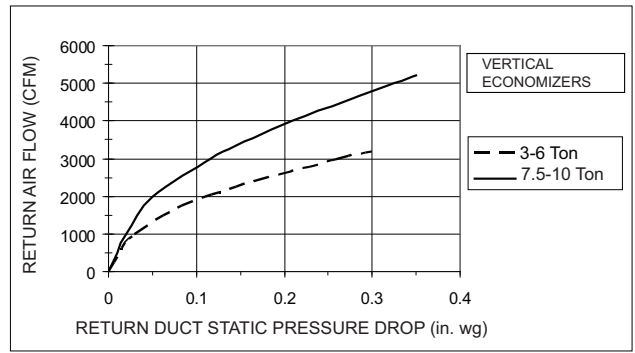

C09885

Fig. 19 - Return Air Pressure Drop

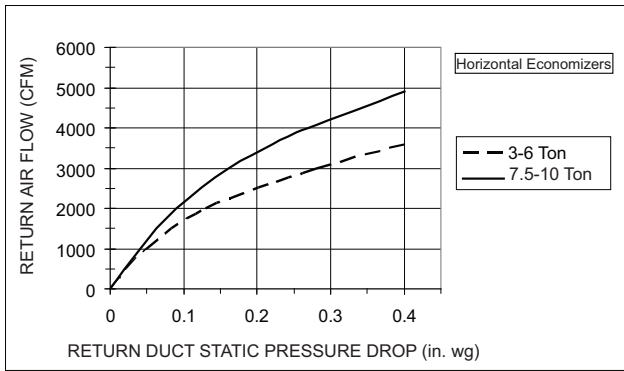

C09881

Fig. 17 - Return Air Pressure Drop

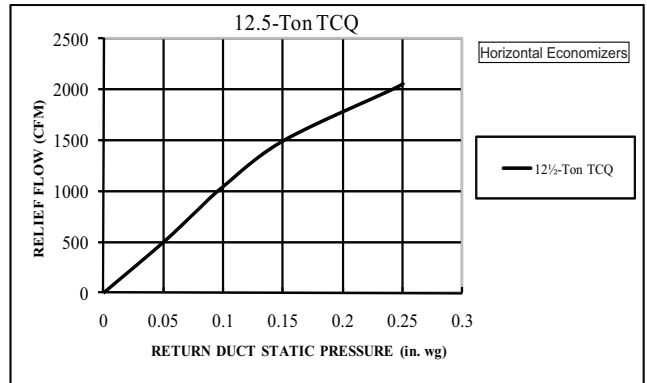

C10258

Fig. 20 - Relief Flow

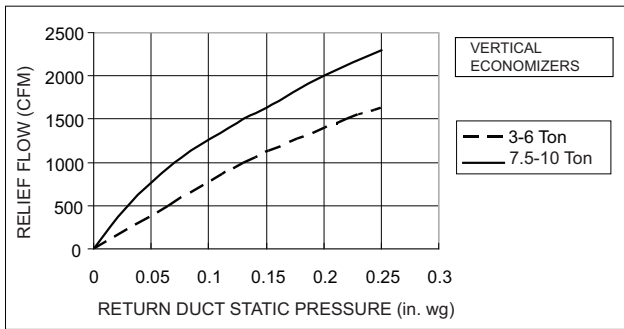

C09883

Fig. 18 - Barometric Relief Flow Capacity

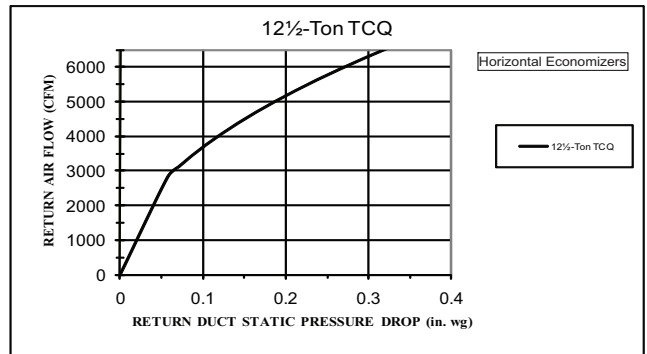

C10260

Fig. 21 - Return Air Flow

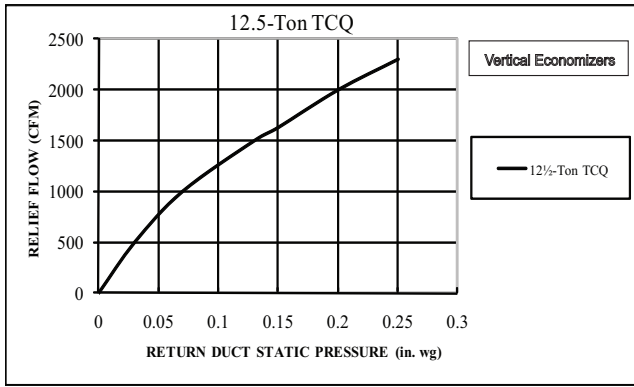

C10262

Fig. 22 - Relief Flow

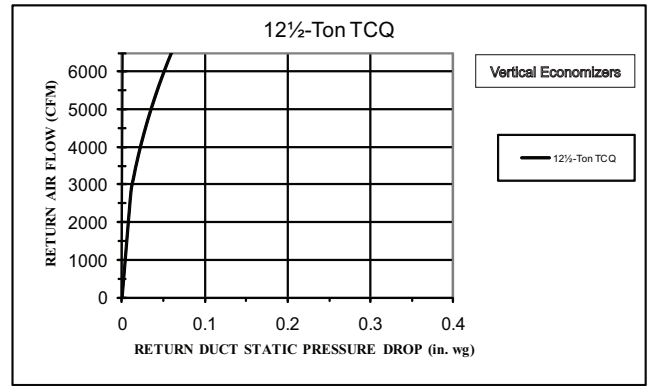

C10264

Fig. 23 - Return Air Flow

GENERAL FAN PERFORMANCE NOTES

1. Interpolation is permissible. Do not extrapolate.
2. External static pressure is the static pressure difference between the return duct and the supply duct plus the static pressure caused by any FIOPs or accessories.
3. Tabular data accounts for pressure loss due to clean filters, unit casing, and wet coils. Factory options and accessories may add static pressure losses, as shown in Table 43. Selection software is available, through your salesperson, to help you select the best motor/drive combination for your application.
4. The Fan Performance tables offer motor/drive recommendations. In cases when two motor/drive combinations would work, Carrier recommended the lower horsepower option.
5. For information on the electrical properties of Carrier motors, please see the Electrical information section of this book.
6. For more information on the performance limits of Carrier motors, see the application data section of this book.

FAN PERFORMANCE

Table 44 – 50TCQA04 ELECTRIC DRIVE, X13 MOTOR, 3 TON HORIZONTAL SUPPLY

SPEED (TORQUE) TAP	CFM	ESP	BHP
1	900	0.70	0.31
	975	0.60	0.30
	1050	0.50	0.29
	1125	0.39	0.27
	1200	0.29	0.26
	1275	0.21	0.24
	1350	0.12	0.23
	1425	0.03	0.21
1500	–	–	
2	900	0.85	0.37
	975	0.76	0.36
	1050	0.66	0.36
	1125	0.55	0.34
	1200	0.46	0.34
	1275	0.36	0.32
	1350	0.27	0.31
	1425	0.17	0.29
1500	0.07	0.27	
3	900	1.02	0.44
	975	0.94	0.45
	1050	0.86	0.45
	1125	0.79	0.45
	1200	0.71	0.45
	1275	0.61	0.44
	1350	0.51	0.43
	1425	0.40	0.41
1500	0.29	0.39	
4	900	1.12	0.49
	975	1.06	0.50
	1050	1.00	0.52
	1125	0.95	0.53
	1200	0.89	0.54
	1275	0.80	0.53
	1350	0.70	0.52
	1425	0.57	0.50
1500	0.46	0.49	
5	900	1.18	0.52
	975	1.14	0.54
	1050	1.10	0.56
	1125	1.06	0.58
	1200	1.02	0.60
	1275	0.98	0.63
	1350	0.94	0.65
	1425	0.90	0.68
1500	0.87	0.71	

Table 45 – 50TCQA04 ELECTRIC DRIVE, X13 MOTOR, 3 TON VERTICAL SUPPLY

SPEED (TORQUE) TAP	CFM	ESP	BHP
1	900	0.44	0.22
	975	0.35	0.21
	1050	0.24	0.20
	1125	0.15	0.19
	1200	0.08	0.19
	1275	0.02	0.18
	1350	–	–
	1425	–	–
1500	–	–	
2	900	0.64	0.30
	975	0.53	0.29
	1050	0.42	0.28
	1125	0.32	0.27
	1200	0.24	0.26
	1275	0.15	0.25
	1350	0.07	0.24
	1425	–	–
1500	–	–	
3	900	0.93	0.42
	975	0.80	0.41
	1050	0.68	0.39
	1125	0.57	0.38
	1200	0.47	0.37
	1275	0.35	0.36
	1350	0.26	0.34
	1425	0.13	0.33
1500	0.08	0.32	
4	900	1.04	0.47
	975	0.92	0.46
	1050	0.80	0.45
	1125	0.71	0.45
	1200	0.62	0.45
	1275	0.52	0.44
	1350	0.43	0.44
	1425	0.27	0.42
1500	0.22	0.41	
5	900	1.10	0.50
	975	1.00	0.49
	1050	0.90	0.49
	1125	0.82	0.50
	1200	0.75	0.51
	1275	0.70	0.54
	1350	0.67	0.57
	1425	0.60	0.60
1500	0.62	0.64	

50TCQ

FAN PERFORMANCE (cont.)

Table 46 – 50TCQA05 ELECTRIC DRIVE, X13 MOTOR, 4 TON HORIZONTAL SUPPLY

SPEED (TORQUE) TAP	CFM	ESP	BHP
1	1200	0.75	0.48
	1300	0.63	0.46
	1400	0.48	0.44
	1500	0.33	0.41
	1600	0.19	0.39
	1700	0.05	0.36
	1800	–	–
	1900	–	–
	2000	–	–
2	1200	0.97	0.58
	1300	0.88	0.59
	1400	0.77	0.59
	1500	0.64	0.59
	1600	0.50	0.57
	1700	0.36	0.54
	1800	0.21	0.52
	1900	0.06	0.49
	2000	–	–
3	1200	0.98	0.59
	1300	0.91	0.60
	1400	0.82	0.62
	1500	0.71	0.62
	1600	0.58	0.61
	1700	0.45	0.60
	1800	0.31	0.58
	1900	0.16	0.56
	2000	0.03	0.52
4	1200	0.98	0.59
	1300	0.92	0.62
	1400	0.86	0.64
	1500	0.79	0.66
	1600	0.70	0.68
	1700	0.62	0.70
	1800	0.52	0.71
	1900	0.37	0.69
	2000	0.21	0.67
5	1200	1.02	0.60
	1300	0.97	0.64
	1400	0.92	0.67
	1500	0.87	0.71
	1600	0.82	0.75
	1700	0.77	0.79
	1800	0.71	0.84
	1900	0.65	0.88
	2000	0.58	0.92

Table 47 – 50TCQA05 ELECTRIC DRIVE, X13 MOTOR, 4 TON VERTICAL SUPPLY

SPEED (TORQUE) TAP	CFM	ESP	BHP
1	1200	0.50	0.39
	1300	0.36	0.37
	1400	0.19	0.35
	1500	0.10	0.33
	1600	0.02	0.32
	1700	–	–
	1800	–	–
	1900	–	–
	2000	–	–
2	1200	0.80	0.55
	1300	0.69	0.55
	1400	0.50	0.54
	1500	0.38	0.52
	1600	0.24	0.50
	1700	0.13	0.48
	1800	0.01	0.46
	1900	–	–
	2000	–	–
3	1200	0.89	0.59
	1300	0.78	0.61
	1400	0.59	0.60
	1500	0.46	0.58
	1600	0.31	0.56
	1700	0.20	0.54
	1800	0.07	0.52
	1900	–	–
	2000	–	–
4	1200	0.89	0.60
	1300	0.80	0.63
	1400	0.67	0.64
	1500	0.57	0.65
	1600	0.43	0.65
	1700	0.31	0.66
	1800	0.23	0.65
	1900	0.12	0.63
	2000	0.01	0.62
5	1200	0.94	0.62
	1300	0.85	0.65
	1400	0.73	0.68
	1500	0.65	0.70
	1600	0.55	0.72
	1700	0.47	0.75
	1800	0.42	0.78
	1900	0.39	0.82
	2000	0.38	0.88

50TCQ

FAN PERFORMANCE (cont.)

Table 48 – 50TCQA06 ELECTRIC DRIVE, X13 MOTOR, 5 TON HORIZONTAL SUPPLY

SPEED (TORQUE) TAP	CFM	ESP	BHP
1	1500	1.19	0.74
	1625	1.01	0.73
	1750	0.82	0.70
	1875	0.60	0.66
	2000	0.38	0.62
	2125	0.16	0.57
	2250	–	–
	2375	–	–
	2500	–	–
2	1500	1.40	0.86
	1625	1.25	0.88
	1750	1.08	0.86
	1875	0.90	0.84
	2000	0.67	0.80
	2125	0.44	0.75
	2250	0.20	0.71
	2375	–	–
	2500	–	–
3	1500	1.41	0.87
	1625	1.28	0.89
	1750	1.13	0.89
	1875	0.96	0.88
	2000	0.74	0.85
	2125	0.51	0.80
	2250	0.27	0.75
	2375	0.02	0.70
	2500	–	–
4	1500	1.44	0.89
	1625	1.35	0.93
	1750	1.24	0.96
	1875	1.11	0.98
	2000	0.90	0.96
	2125	0.69	0.92
	2250	0.43	0.86
	2375	0.17	0.81
	2500	–	–
5	1500	1.49	0.90
	1625	1.38	0.95
	1750	1.28	1.00
	1875	1.18	1.05
	2000	1.11	1.09
	2125	0.97	1.11
	2250	0.72	1.07
	2375	0.47	1.02
	2500	0.20	0.96

Table 49 – 50TCQA06 ELECTRIC DRIVE, X13 MOTOR, 5 TON VERTICAL SUPPLY

SPEED (TORQUE) TAP	CFM	ESP	BHP
1	1500	1.00	0.70
	1625	0.72	0.65
	1750	0.46	0.60
	1875	0.28	0.55
	2000	0.14	0.51
	2125	0.00	0.52
	2250	–	–
	2375	–	–
	2500	–	–
2	1500	1.18	0.88
	1625	1.00	0.90
	1750	0.75	0.87
	1875	0.51	0.83
	2000	0.30	0.79
	2125	0.13	0.75
	2250	–	–
	2375	–	–
	2500	–	–
3	1500	1.19	0.88
	1625	1.03	0.91
	1750	0.80	0.90
	1875	0.56	0.87
	2000	0.35	0.83
	2125	0.19	0.80
	2250	0.01	0.77
	2375	–	–
	2500	–	–
4	1500	1.25	0.89
	1625	1.09	0.93
	1750	0.89	0.96
	1875	0.65	0.94
	2000	0.45	0.93
	2125	0.26	0.89
	2250	0.12	0.86
	2375	–	–
	2500	–	–
5	1500	1.26	0.90
	1625	1.16	0.96
	1750	0.99	1.01
	1875	0.80	1.05
	2000	0.67	1.07
	2125	0.48	1.07
	2250	0.26	1.03
	2375	0.11	1.00
	2500	–	–

50TCQ

FAN PERFORMANCE (cont.)

Table 50 – 50TCQA04

3 TON HORIZONTAL SUPPLY

CFM	AVAILABLE EXTERNAL STATIC PRESSURE (IN. WG)									
	0.2		0.4		0.6		0.8		1.0	
	RPM	BHP	RPM	BHP	RPM	BHP	RPM	BHP	RPM	BHP
900	574	0.13	707	0.23	817	0.34	913	0.47	999	0.61
975	597	0.15	727	0.25	835	0.37	929	0.50	1015	0.64
1050	621	0.18	747	0.28	853	0.40	946	0.53	1030	0.68
1125	646	0.20	768	0.31	872	0.43	964	0.57	1047	0.72
1200	671	0.23	790	0.34	892	0.47	982	0.61	1064	0.76
1275	696	0.26	812	0.38	912	0.51	1001	0.65	1082	0.81
1350	723	0.30	835	0.42	933	0.55	1020	0.70	1100	0.86
1425	749	0.34	859	0.46	955	0.60	1040	0.75	1119	0.91
1500	776	0.38	883	0.51	977	0.65	1061	0.80	1138	0.97

Med static – 819–1251 RPM, Max BHP 1.5

High static – 1035–1466 RPM, Max BHP 2.0

CFM	AVAILABLE EXTERNAL STATIC PRESSURE (IN. WG)									
	1.2		1.4		1.6		1.8		2.0	
	RPM	BHP	RPM	BHP	RPM	BHP	RPM	BHP	RPM	BHP
900	1078	0.77	1151	0.93	1220	1.11	1284	1.30	1346	1.49
975	1093	0.80	1165	0.97	1233	1.15	1297	1.33	1358	1.53
1050	1108	0.84	1180	1.01	1247	1.19	1311	1.38	1371	1.58
1125	1123	0.88	1195	1.05	1261	1.23	1325	1.42	1385	1.62
1200	1140	0.92	1210	1.10	1276	1.28	1339	1.47	1399	1.68
1275	1157	0.97	1226	1.15	1292	1.33	1354	1.53	1414	1.73
1350	1174	1.02	1243	1.20	1308	1.39	1370	1.59	1429	1.80
1425	1192	1.08	1260	1.26	1325	1.45	1386	1.65	1444	1.86
1500	1210	1.14	1278	1.33	1342	1.52	1403	1.72	1461	1.93

Med static – 819–1251 RPM, Max BHP 1.5

High static – 1035–1466 RPM, Max BHP 2.0

50TCQ

Table 51 – 50TCQA04

3 TON VERTICAL SUPPLY

CFM	AVAILABLE EXTERNAL STATIC PRESSURE (IN. WG)									
	0.2		0.4		0.6		0.8		1.0	
	RPM	BHP	RPM	BHP	RPM	BHP	RPM	BHP	RPM	BHP
900	594	0.15	740	0.25	867	0.37	981	0.52	1084	0.68
975	618	0.17	758	0.28	881	0.40	991	0.55	1092	0.71
1050	642	0.19	777	0.30	896	0.43	1003	0.58	1102	0.75
1125	668	0.22	797	0.34	912	0.47	1017	0.62	1113	0.79
1200	695	0.25	818	0.37	930	0.51	1032	0.66	1126	0.83
1275	722	0.29	841	0.41	949	0.55	1048	0.71	1140	0.88
1350	750	0.33	864	0.46	968	0.60	1065	0.76	1155	0.93
1425	778	0.37	888	0.50	989	0.65	1083	0.81	1171	0.99
1500	807	0.42	913	0.56	1011	0.71	1103	0.87	1188	1.05

Med static – 819–1251 RPM, Max BHP 1.5

High static – 1035–1466 RPM, Max BHP 2.0

CFM	AVAILABLE EXTERNAL STATIC PRESSURE (IN. WG)									
	1.2		1.4		1.6		1.8		2.0	
	RPM	BHP	RPM	BHP	RPM	BHP	RPM	BHP	RPM	BHP
900	1180	0.86	1269	1.05	1354	1.25	1434	1.47	1511	1.70
975	1186	0.89	1275	1.08	1358	1.29	1437	1.51	1513	1.74
1050	1194	0.92	1281	1.12	1363	1.32	1441	1.54	1516	1.78
1125	1204	0.97	1289	1.16	1370	1.37	1447	1.59	1520	1.82
1200	1215	1.01	1298	1.21	1378	1.42	1454	1.64	1526	1.87
1275	1227	1.06	1309	1.26	1387	1.47	1462	1.69	1533	1.92
1350	1240	1.12	1321	1.32	1397	1.53	1471	1.75	1541	1.99
1425	1254	1.18	1333	1.38	1409	1.59	1481	1.82	–	–
1500	1270	1.24	1347	1.45	1421	1.66	1492	1.89	–	–

Med static – 819–1251 RPM, Max BHP 1.5

High static – 1035–1466 RPM, Max BHP 2.0

Bold Face indicates field–supplied drive

Recommend using field–supplied fan pulley (part no. KR11AD561), motor pulley (part no. KR11HY181) and belt (part no. KR29AF041).

FAN PERFORMANCE (cont.)

Table 52 – 50TCQA05

4 TON HORIZONTAL SUPPLY

CFM	AVAILABLE EXTERNAL STATIC PRESSURE (IN. WG)									
	0.2		0.4		0.6		0.8		1.0	
	RPM	BHP	RPM	BHP	RPM	BHP	RPM	BHP	RPM	BHP
1200	671	0.23	790	0.34	892	0.47	982	0.61	1064	0.76
1300	705	0.28	820	0.39	919	0.52	1007	0.67	1088	0.82
1400	740	0.33	851	0.45	947	0.58	1034	0.73	1113	0.89
1500	776	0.38	883	0.51	977	0.65	1061	0.80	1138	0.97
1600	813	0.45	916	0.58	1007	0.73	1089	0.89	1165	1.05
1700	851	0.52	949	0.66	1038	0.81	1118	0.97	1192	1.15
1800	888	0.60	984	0.75	1069	0.90	1148	1.07	1221	1.25
1900	927	0.69	1019	0.84	1102	1.00	1179	1.18	1250	1.36
2000	965	0.78	1054	0.94	1135	1.11	1210	1.29	1280	1.48

Med static – 920–1303 RPM, Max BHP 1.5

High static – 1035–1466 RPM, Max BHP 2.0

50TCQ

CFM	AVAILABLE EXTERNAL STATIC PRESSURE (IN. WG)									
	1.2		1.4		1.6		1.8		2.0	
	RPM	BHP	RPM	BHP	RPM	BHP	RPM	BHP	RPM	BHP
1200	1140	0.92	1210	1.10	1276	1.28	1339	1.47	1399	1.68
1300	1162	0.99	1232	1.16	1297	1.35	1360	1.55	1419	1.75
1400	1186	1.06	1254	1.24	1319	1.43	1381	1.63	1439	1.84
1500	1210	1.14	1278	1.33	1342	1.52	1403	1.72	1461	1.93
1600	1236	1.23	1302	1.42	1365	1.62	1425	1.82	1483	2.04
1700	1262	1.33	1328	1.52	1390	1.72	1449	1.93	1505	2.15
1800	1289	1.44	1354	1.63	1415	1.84	1473	2.05	1529	2.27
1900	1317	1.55	1380	1.75	1441	1.96	1498	2.18	–	–
2000	1345	1.68	1408	1.88	1467	2.10	1524	2.32	–	–

Med static – 920–1303 RPM, Max BHP 1.5

High static – 1035–1466 RPM, Max BHP 2.0

Bold Face indicates field–supplied drive

Recommend using field–supplied fan pulley (part no. KR11AD561), motor pulley (part no. KR11HY181) and belt (part no. KR29AF041).

Table 53 – 50TCQA05

4 TON VERTICAL SUPPLY

CFM	AVAILABLE EXTERNAL STATIC PRESSURE (IN. WG)									
	0.2		0.4		0.6		0.8		1.0	
	RPM	BHP	RPM	BHP	RPM	BHP	RPM	BHP	RPM	BHP
1200	695	0.25	818	0.37	930	0.51	1032	0.66	1126	0.83
1300	731	0.30	849	0.43	955	0.57	1053	0.72	1145	0.89
1400	769	0.36	880	0.49	982	0.63	1077	0.79	1166	0.97
1500	807	0.42	913	0.56	1011	0.71	1103	0.87	1188	1.05
1600	847	0.49	948	0.63	1042	0.79	1130	0.96	1213	1.14
1700	887	0.57	983	0.72	1073	0.88	1158	1.06	1239	1.24
1800	928	0.66	1020	0.82	1106	0.98	1188	1.16	1266	1.35
1900	969	0.76	1057	0.92	1140	1.09	1219	1.28	1295	1.48
2000	1010	0.87	1095	1.04	1175	1.21	1251	1.41	1325	1.61

Med static – 920–1303 RPM, Max BHP 1.5

High static – 1035–1466 RPM, Max BHP 2.0

CFM	AVAILABLE EXTERNAL STATIC PRESSURE (IN. WG)									
	1.2		1.4		1.6		1.8		2.0	
	RPM	BHP	RPM	BHP	RPM	BHP	RPM	BHP	RPM	BHP
1200	1215	1.01	1298	1.21	1378	1.42	1454	1.64	1526	1.87
1300	1231	1.08	1313	1.28	1390	1.49	1465	1.71	1536	1.94
1400	1249	1.16	1329	1.36	1405	1.57	1478	1.79	–	–
1500	1270	1.24	1347	1.45	1421	1.66	1492	1.89	–	–
1600	1292	1.34	1367	1.54	1440	1.76	1509	1.99	–	–
1700	1315	1.44	1389	1.65	1459	1.88	1527	2.11	–	–
1800	1341	1.56	1412	1.77	1481	2.00	–	–	–	–
1900	1367	1.68	1437	1.90	1504	2.13	–	–	–	–
2000	1395	1.82	1463	2.04	1528	2.28	–	–	–	–

Med static – 920–1303 RPM, Max BHP 1.5

High static – 1035–1466 RPM, Max BHP 2.0

Bold Face indicates field–supplied drive

Recommend using field–supplied fan pulley (part no. KR11AD561), motor pulley (part no. KR11HY181) and belt (part no. KR29AF041).

FAN PERFORMANCE (cont.)

Table 54 – 50TCQA06

5 TON HORIZONTAL SUPPLY

CFM	AVAILABLE EXTERNAL STATIC PRESSURE (IN. WG)									
	0.2		0.4		0.6		0.8		1.0	
	RPM	BHP	RPM	BHP	RPM	BHP	RPM	BHP	RPM	BHP
1500	725	0.33	840	0.46	937	0.60	1023	0.75	1101	0.90
1625	765	0.40	876	0.54	970	0.68	1054	0.84	1131	1.00
1750	806	0.48	912	0.63	1004	0.78	1087	0.94	1162	1.11
1875	847	0.57	950	0.72	1039	0.88	1120	1.05	1194	1.23
2000	889	0.66	988	0.83	1075	1.00	1154	1.18	1226	1.36
2125	931	0.78	1027	0.95	1112	1.13	1189	1.31	1260	1.50
2250	974	0.90	1067	1.08	1149	1.27	1224	1.46	1294	1.66
2375	1018	1.03	1107	1.23	1187	1.43	1261	1.63	1329	1.84
2500	1061	1.19	1148	1.39	1226	1.59	1297	1.81	1364	2.02

Med static – 1066–1380 RPM, Max BHP 2.0

High static – 1208–1639 RPM, Max BHP 2.9

CFM	AVAILABLE EXTERNAL STATIC PRESSURE (IN. WG)									
	1.2		1.4		1.6		1.8		2.0	
	RPM	BHP	RPM	BHP	RPM	BHP	RPM	BHP	RPM	BHP
1500	1172	1.06	1239	1.23	1302	1.40	1361	1.58	1418	1.77
1625	1201	1.16	1267	1.34	1329	1.52	1388	1.71	1444	1.90
1750	1231	1.28	1296	1.46	1358	1.65	1416	1.84	1472	2.04
1875	1262	1.41	1326	1.60	1387	1.79	1445	1.99	1499	2.20
2000	1294	1.55	1357	1.74	1417	1.95	1474	2.15	1528	2.36
2125	1326	1.70	1388	1.90	1447	2.11	1504	2.33	1557	2.55
2250	1359	1.87	1420	2.08	1479	2.29	1534	2.51	1587	2.74
2375	1393	2.05	1453	2.27	1511	2.49	1566	2.72	1618	2.95
2500	1427	2.24	1487	2.47	1543	2.70	1597	2.94	1649	3.18

Med static – 1066–1380 RPM, Max BHP 2.0

High static – 1208–1639 RPM, Max BHP 2.9

Table 55 – 50TCQA06

5 TON VERTICAL SUPPLY

CFM	AVAILABLE EXTERNAL STATIC PRESSURE (IN. WG)									
	0.2		0.4		0.6		0.8		1.0	
	RPM	BHP	RPM	BHP	RPM	BHP	RPM	BHP	RPM	BHP
1500	794	0.41	902	0.55	993	0.69	1074	0.85	1147	1.00
1625	840	0.49	945	0.64	1034	0.80	1113	0.96	1185	1.13
1750	888	0.59	988	0.75	1075	0.92	1153	1.09	1223	1.26
1875	936	0.70	1033	0.87	1117	1.05	1193	1.23	1263	1.41
2000	984	0.82	1078	1.00	1160	1.19	1235	1.39	1303	1.58
2125	1033	0.96	1124	1.15	1204	1.35	1277	1.56	1343	1.76
2250	1083	1.11	1170	1.32	1248	1.53	1319	1.74	1385	1.96
2375	1133	1.28	1217	1.50	1293	1.72	1363	1.95	1427	2.17
2500	1183	1.47	1265	1.70	1339	1.93	1406	2.17	1470	2.41

Med static – 1066–1380 RPM, Max BHP 2.0

High static – 1208–1639 RPM, Max BHP 2.9

CFM	AVAILABLE EXTERNAL STATIC PRESSURE (IN. WG)									
	1.2		1.4		1.6		1.8		2.0	
	RPM	BHP	RPM	BHP	RPM	BHP	RPM	BHP	RPM	BHP
1500	1214	1.16	1277	1.33	1336	1.50	1392	1.67	1445	1.85
1625	1251	1.30	1313	1.47	1371	1.65	1427	1.83	1479	2.02
1750	1289	1.44	1350	1.63	1407	1.81	1462	2.01	1514	2.20
1875	1327	1.60	1387	1.80	1444	1.99	1498	2.19	1550	2.40
2000	1366	1.78	1426	1.98	1482	2.19	1535	2.40	1586	2.61
2125	1406	1.97	1464	2.18	1520	2.40	1573	2.62	1623	2.84
2250	1446	2.18	1504	2.40	1559	2.62	1611	2.85	1661	3.09
2375	1487	2.40	1544	2.63	1598	2.87	1650	3.11	-	-
2500	1529	2.64	1585	2.89	1638	3.13	-	-	-	-

Med static – 1066–1380 RPM, Max BHP 2.0

High static – 1208–1639 RPM, Max BHP 2.9

50TCQ

FAN PERFORMANCE (cont.)

Table 56 – 50TCQA07

6 TON HORIZONTAL SUPPLY

CFM	AVAILABLE EXTERNAL STATIC PRESSURE (IN. WG)									
	0.2		0.4		0.6		0.8		1.0	
	RPM	BHP	RPM	BHP	RPM	BHP	RPM	BHP	RPM	BHP
1800	822	0.51	927	0.66	1018	0.82	1100	0.98	1174	1.15
1950	872	0.62	973	0.79	1061	0.95	1140	1.13	1213	1.31
2100	923	0.75	1019	0.92	1104	1.10	1182	1.29	1253	1.48
2250	974	0.90	1067	1.08	1149	1.27	1224	1.46	1294	1.66
2400	1026	1.06	1115	1.26	1195	1.46	1268	1.66	1336	1.87
2550	1079	1.25	1164	1.46	1241	1.67	1312	1.88	1379	2.10
2700	1132	1.46	1214	1.67	1289	1.90	1358	2.12	1422	2.35
2850	1186	1.69	1264	1.92	1336	2.15	1404	2.39	1467	2.63
3000	1240	1.94	1315	2.18	1385	2.43	1451	2.68	1512	2.93

Std static – 878–1192 RPM, Max BHP 1.5

Med static – 1066–1380 RPM, Max BHP 2.9

High static – 1208–1639 RPM, Max BHP 2.9

50TCQ

CFM	AVAILABLE EXTERNAL STATIC PRESSURE (IN. WG)									
	1.2		1.4		1.6		1.8		2.0	
	RPM	BHP	RPM	BHP	RPM	BHP	RPM	BHP	RPM	BHP
1800	1244	1.33	1308	1.51	1369	1.70	1427	1.90	1483	2.10
1950	1281	1.49	1345	1.68	1405	1.88	1462	2.09	1517	2.30
2100	1320	1.67	1382	1.87	1441	2.08	1498	2.29	1552	2.51
2250	1359	1.87	1420	2.08	1479	2.29	1534	2.51	1587	2.74
2400	1400	2.09	1460	2.31	1517	2.53	1572	2.76	1624	2.99
2550	1441	2.33	1500	2.55	1557	2.79	1610	3.03	1662	3.27
2700	1483	2.59	1541	2.83	1597	3.07	1650	3.32	–	–
2850	1527	2.87	1583	3.12	1638	3.37	–	–	–	–
3000	1571	3.18	1626	3.44	1680	3.70	–	–	–	–

Std static – 878–1192 RPM, Max BHP 1.5

Med static – 1066–1380 RPM, Max BHP 2.9

High static – 1208–1639 RPM, Max BHP 2.9

Table 57 – 50TCQA07

6 TON VERTICAL SUPPLY

CFM	AVAILABLE EXTERNAL STATIC PRESSURE (IN. WG)									
	0.2		0.4		0.6		0.8		1.0	
	RPM	BHP	RPM	BHP	RPM	BHP	RPM	BHP	RPM	BHP
1800	907	0.63	1006	0.80	1092	0.97	1169	1.14	1239	1.32
1950	965	0.77	1060	0.95	1143	1.13	1218	1.32	1287	1.51
2100	1024	0.93	1115	1.12	1195	1.32	1268	1.52	1335	1.72
2250	1083	1.11	1170	1.32	1248	1.53	1319	1.74	1385	1.96
2400	1143	1.32	1227	1.54	1302	1.76	1371	1.99	1435	2.22
2550	1203	1.55	1284	1.78	1357	2.02	1424	2.26	1487	2.50
2700	1264	1.81	1342	2.06	1412	2.31	1478	2.56	1539	2.82
2850	1326	2.09	1400	2.36	1469	2.62	1532	2.89	1592	3.16
3000	1387	2.41	1459	2.69	1525	2.97	1587	3.25	1646	3.53

Std static – 878–1192 RPM, Max BHP 1.5

Med static – 1066–1380 RPM, Max BHP 2.9

High static – 1208–1639 RPM, Max BHP 2.9

CFM	AVAILABLE EXTERNAL STATIC PRESSURE (IN. WG)									
	1.2		1.4		1.6		1.8		2.0	
	RPM	BHP	RPM	BHP	RPM	BHP	RPM	BHP	RPM	BHP
1800	1304	1.51	1365	1.69	1422	1.88	1477	2.08	1528	2.28
1950	1350	1.71	1410	1.91	1467	2.11	1520	2.31	1572	2.52
2100	1398	1.93	1457	2.14	1512	2.35	1565	2.57	1616	2.79
2250	1446	2.18	1504	2.40	1559	2.62	1611	2.85	1661	3.09
2400	1496	2.45	1552	2.68	1606	2.92	1658	3.16	–	–
2550	1546	2.75	1601	2.99	1654	3.24	–	–	–	–
2700	1597	3.07	1651	3.33	–	–	–	–	–	–
2850	1648	3.43	–	–	–	–	–	–	–	–
3000	–	–	–	–	–	–	–	–	–	–

Std static – 878–1192 RPM, Max BHP 1.5

Med static – 1066–1380 RPM, Max BHP 2.9

High static – 1208–1639 RPM, Max BHP 2.9

FAN PERFORMANCE (cont.)

Table 58 – 50TCQD08

7.5 TON HORIZONTAL SUPPLY

CFM	AVAILABLE EXTERNAL STATIC PRESSURE (IN. WG)									
	0.2		0.4		0.6		0.8		1.0	
	RPM	BHP	RPM	BHP	RPM	BHP	RPM	BHP	RPM	BHP
2250	423	0.28	509	0.40	587	0.52	659	0.66	725	0.80
2438	444	0.34	525	0.46	600	0.59	669	0.73	733	0.88
2625	465	0.40	543	0.53	614	0.67	680	0.82	743	0.97
2813	487	0.47	561	0.61	629	0.76	693	0.91	753	1.08
3000	510	0.55	580	0.70	646	0.86	707	1.02	765	1.19
3188	534	0.65	600	0.80	663	0.96	722	1.13	779	1.31
3375	557	0.75	621	0.91	681	1.08	738	1.26	793	1.44
3563	582	0.86	642	1.03	700	1.21	755	1.39	808	1.58
3750	606	0.99	664	1.17	720	1.35	773	1.54	824	1.74

Std static – 460–652 RPM, Max BHP 1.2

Med static – 591–838 RPM, Max BHP 2.9

High static – 838–1084 RPM, Max BHP 2.9

CFM	AVAILABLE EXTERNAL STATIC PRESSURE (IN. WG)									
	1.2		1.4		1.6		1.8		2.0	
	RPM	BHP	RPM	BHP	RPM	BHP	RPM	BHP	RPM	BHP
2250	788	0.94	847	1.09	903	1.25	957	1.41	1009	1.58
2438	794	1.03	852	1.19	907	1.36	959	1.52	1010	1.70
2625	802	1.13	858	1.30	911	1.47	963	1.64	1012	1.82
2813	811	1.24	865	1.41	917	1.59	967	1.77	1016	1.96
3000	821	1.36	874	1.54	925	1.72	974	1.91	1021	2.11
3188	832	1.49	884	1.68	933	1.87	981	2.06	1028	2.26
3375	845	1.63	895	1.82	943	2.02	990	2.22	1035	2.43
3563	858	1.78	907	1.98	954	2.19	1000	2.40	1044	2.61
3750	873	1.94	920	2.15	966	2.36	1011	2.58	1054	2.80

Std static – 460–652 RPM, Max BHP 1.2

Med static – 591–838 RPM, Max BHP 2.9

High static – 838–1084 RPM, Max BHP 2.9

Table 59 – 50TCQD08

7.5 TON VERTICAL SUPPLY

CFM	AVAILABLE EXTERNAL STATIC PRESSURE (IN. WG)									
	0.2		0.4		0.6		0.8		1.0	
	RPM	BHP	RPM	BHP	RPM	BHP	RPM	BHP	RPM	BHP
2250	447	0.31	528	0.43	597	0.54	658	0.66	713	0.78
2438	470	0.37	548	0.50	615	0.62	675	0.75	729	0.88
2625	494	0.45	569	0.58	634	0.71	692	0.85	745	0.99
2813	518	0.53	590	0.67	653	0.82	710	0.96	763	1.11
3000	543	0.62	612	0.77	673	0.93	729	1.08	780	1.24
3188	568	0.72	635	0.89	694	1.05	749	1.21	799	1.38
3375	593	0.84	658	1.01	716	1.19	769	1.36	818	1.53
3563	619	0.97	681	1.15	737	1.33	789	1.52	837	1.70
3750	645	1.11	705	1.30	760	1.49	810	1.68	857	1.88

Std static – 460–652 RPM, Max BHP 1.2

Med static – 591–838 RPM, Max BHP 2.9

High static – 838–1084 RPM, Max BHP 2.9

CFM	AVAILABLE EXTERNAL STATIC PRESSURE (IN. WG)									
	1.2		1.4		1.6		1.8		2.0	
	RPM	BHP	RPM	BHP	RPM	BHP	RPM	BHP	RPM	BHP
2250	764	0.89	812	1.02	856	1.14	899	1.26	939	1.39
2438	779	1.00	826	1.13	870	1.26	912	1.40	952	1.53
2625	795	1.12	841	1.26	885	1.40	926	1.54	966	1.68
2813	811	1.25	857	1.40	900	1.55	941	1.69	980	1.84
3000	828	1.39	873	1.55	916	1.70	956	1.86	995	2.02
3188	846	1.54	890	1.71	932	1.87	972	2.04	1010	2.21
3375	864	1.70	907	1.88	949	2.05	988	2.23	1026	2.40
3563	882	1.88	925	2.06	966	2.25	1005	2.43	1042	2.62
3750	902	2.07	944	2.26	984	2.45	1022	2.65	1059	2.84

Std static – 460–652 RPM, Max BHP 1.2

Med static – 591–838 RPM, Max BHP 2.9

High static – 838–1084 RPM, Max BHP 2.9

50TCQ

FAN PERFORMANCE (cont.)

Table 60 – 50TCQD09

8.5 TON HORIZONTAL SUPPLY

CFM	AVAILABLE EXTERNAL STATIC PRESSURE (IN. WG)									
	0.2		0.4		0.6		0.8		1.0	
	RPM	BHP	RPM	BHP	RPM	BHP	RPM	BHP	RPM	BHP
2550	468	0.39	546	0.52	618	0.66	684	0.80	747	0.96
2763	493	0.47	567	0.61	635	0.76	699	0.91	760	1.07
2975	520	0.57	589	0.72	654	0.87	716	1.03	774	1.20
3188	547	0.68	613	0.83	675	1.00	733	1.17	789	1.34
3400	575	0.80	637	0.96	696	1.14	752	1.31	806	1.50
3613	603	0.94	662	1.11	719	1.29	773	1.48	824	1.67
3825	631	1.09	688	1.27	742	1.46	794	1.66	843	1.86
4038	660	1.26	714	1.45	766	1.65	816	1.85	864	2.06
4250	689	1.45	741	1.65	790	1.86	838	2.07	885	2.29

Std static – 460–652 RPM, Max BHP 1.2

Med static – 591–838 RPM, Max BHP 2.9

High static – 838–1084 RPM, Max BHP 2.9

50TCQ

CFM	AVAILABLE EXTERNAL STATIC PRESSURE (IN. WG)									
	1.2		1.4		1.6		1.8		2.0	
	RPM	BHP	RPM	BHP	RPM	BHP	RPM	BHP	RPM	BHP
2550	806	1.11	863	1.28	916	1.45	968	1.62	1018	1.80
2763	817	1.24	871	1.41	924	1.59	974	1.77	1022	1.95
2975	829	1.37	882	1.55	932	1.74	981	1.93	1028	2.12
3188	843	1.53	894	1.71	943	1.90	990	2.10	1036	2.30
3400	858	1.69	907	1.88	955	2.09	1001	2.29	1046	2.50
3613	874	1.87	922	2.07	968	2.28	1013	2.49	1057	2.71
3825	891	2.07	938	2.28	983	2.49	1027	2.71	1069	2.94
4038	910	2.28	955	2.50	999	2.72	1041	2.95	1083	3.19
4250	930	2.51	973	2.74	1015	2.97	1057	3.21	1097	3.45

Std static – 460–652 RPM, Max BHP 1.2

Med static – 591–838 RPM, Max BHP 2.9

High static – 838–1084 RPM, Max BHP 2.9

Table 61 – 50TCQD09

8.5 VERTICAL SUPPLY

CFM	AVAILABLE EXTERNAL STATIC PRESSURE (IN. WG)									
	0.2		0.4		0.6		0.8		1.0	
	RPM	BHP	RPM	BHP	RPM	BHP	RPM	BHP	RPM	BHP
2550	495	0.43	570	0.56	634	0.70	693	0.83	746	0.96
2763	524	0.53	595	0.67	657	0.81	714	0.95	766	1.09
2975	552	0.63	620	0.79	681	0.94	736	1.09	787	1.24
3188	582	0.76	647	0.92	705	1.08	759	1.25	808	1.41
3400	611	0.89	674	1.07	730	1.24	782	1.42	831	1.59
3613	641	1.05	701	1.23	756	1.42	806	1.60	854	1.79
3825	672	1.22	729	1.42	782	1.61	831	1.81	877	2.00
4038	702	1.41	758	1.62	809	1.83	857	2.03	901	2.24
4250	733	1.62	787	1.84	836	2.06	883	2.28	926	2.49

Std static – 460–652 RPM, Max BHP 1.2

Med static – 591–838 RPM, Max BHP 2.9

High static – 838–1084 RPM, Max BHP 2.9

CFM	AVAILABLE EXTERNAL STATIC PRESSURE (IN. WG)									
	1.2		1.4		1.6		1.8		2.0	
	RPM	BHP	RPM	BHP	RPM	BHP	RPM	BHP	RPM	BHP
2550	795	1.09	841	1.23	885	1.36	926	1.50	965	1.64
2763	814	1.24	859	1.38	902	1.53	943	1.68	982	1.82
2975	834	1.40	878	1.55	921	1.71	961	1.86	999	2.02
3188	855	1.57	898	1.74	940	1.90	979	2.07	1017	2.24
3400	876	1.76	919	1.94	960	2.12	998	2.29	1036	2.47
3613	898	1.97	940	2.16	980	2.34	1018	2.53	1055	2.72
3825	921	2.20	962	2.40	1001	2.59	1039	2.79	1075	2.99
4038	944	2.45	984	2.65	1023	2.86	1060	3.07	1096	3.27
4250	968	2.71	1007	2.93	1045	3.15	1081	3.36	1117	3.58

Std static – 460–652 RPM, Max BHP 1.2

Med static – 591–838 RPM, Max BHP 2.9

High static – 838–1084 RPM, Max BHP 2.9

FAN PERFORMANCE (cont.)

Table 62 – 50TCQD12

10 TON HORIZONTAL SUPPLY

CFM	AVAILABLE EXTERNAL STATIC PRESSURE (IN. WG)									
	0.2		0.4		0.6		0.8		1.0	
	RPM	BHP	RPM	BHP	RPM	BHP	RPM	BHP	RPM	BHP
3000	523	0.58	592	0.73	657	0.88	718	1.05	775	1.22
3250	555	0.71	620	0.87	681	1.04	739	1.21	794	1.39
3500	588	0.86	649	1.03	707	1.21	762	1.39	815	1.58
3750	621	1.03	679	1.21	734	1.40	786	1.59	837	1.79
4000	655	1.23	709	1.42	761	1.61	812	1.82	860	2.03
4250	689	1.45	741	1.65	790	1.86	838	2.07	885	2.29
4500	723	1.69	773	1.90	820	2.12	866	2.35	910	2.57
4750	758	1.96	805	2.19	850	2.42	894	2.65	937	2.89
5000	793	2.26	838	2.50	881	2.74	923	2.98	965	3.23

Std static – 591–839 RPM, Max BHP 1.2

Med static – 733–949 RPM, Max BHP 2.9

High static – 838–1084 RPM, Max BHP 3.7

CFM	AVAILABLE EXTERNAL STATIC PRESSURE (IN. WG)									
	1.2		1.4		1.6		1.8		2.0	
	RPM	BHP	RPM	BHP	RPM	BHP	RPM	BHP	RPM	BHP
3000	830	1.39	883	1.57	934	1.76	982	1.95	1029	2.14
3250	847	1.57	897	1.76	946	1.96	993	2.16	1039	2.36
3500	865	1.77	914	1.97	961	2.18	1007	2.38	1051	2.60
3750	885	1.99	932	2.20	978	2.42	1022	2.64	1065	2.86
4000	907	2.24	952	2.46	996	2.68	1038	2.91	1080	3.14
4250	930	2.51	973	2.74	1015	2.97	1057	3.21	1097	3.45
4500	954	2.81	996	3.05	1037	3.29	1076	3.54	1115	3.79
4750	979	3.13	1019	3.38	1059	3.63	1097	3.89	1135	4.15
5000	1005	3.49	1044	3.74	1082	4.01	1119	4.27	1156	4.55

Std static – 591–839 RPM, Max BHP 2.4

Med static – 733–949 RPM, Max BHP 2.9

High static – 838–1084 RPM, Max BHP 3.7

Table 63 – 50TCQD12

10 VERTICAL SUPPLY

CFM	AVAILABLE EXTERNAL STATIC PRESSURE (IN. WG)									
	0.2		0.4		0.6		0.8		1.0	
	RPM	BHP	RPM	BHP	RPM	BHP	RPM	BHP	RPM	BHP
3000	556	0.65	623	0.80	684	0.95	738	1.11	789	1.26
3250	590	0.79	655	0.96	713	1.13	766	1.29	815	1.46
3500	625	0.96	687	1.14	742	1.32	794	1.50	841	1.68
3750	661	1.16	719	1.35	773	1.54	822	1.73	869	1.93
4000	697	1.37	753	1.58	804	1.79	852	1.99	897	2.20
4250	733	1.62	787	1.84	836	2.06	883	2.28	926	2.49
4500	770	1.89	821	2.13	869	2.36	914	2.59	956	2.82
4750	807	2.20	856	2.45	902	2.69	945	2.94	986	3.18
5000	844	2.54	891	2.80	936	3.06	978	3.31	1018	3.57

Std static – 591–839 RPM, Max BHP 2.4

Med static – 733–949 RPM, Max BHP 2.9

High static – 838–1084 RPM, Max BHP 3.7

CFM	AVAILABLE EXTERNAL STATIC PRESSURE (IN. WG)									
	1.2		1.4		1.6		1.8		2.0	
	RPM	BHP	RPM	BHP	RPM	BHP	RPM	BHP	RPM	BHP
3000	836	1.42	881	1.57	923	1.73	963	1.89	1001	2.05
3250	861	1.63	904	1.79	945	1.96	985	2.13	1023	2.30
3500	886	1.86	929	2.04	969	2.22	1008	2.40	1045	2.58
3750	912	2.12	954	2.31	994	2.50	1031	2.70	1068	2.89
4000	940	2.40	980	2.61	1019	2.81	1056	3.02	1092	3.22
4250	968	2.71	1007	2.93	1045	3.15	1081	3.36	1117	3.58
4500	996	3.05	1035	3.28	1072	3.51	1108	3.74	1142	3.97
4750	1026	3.42	1063	3.66	1100	3.91	1135	4.15	1168	4.39
5000	1056	3.82	1093	4.08	1128	4.34	1162	4.59	–	–

Std static – 591–839 RPM, Max BHP 2.4

Med static – 733–949 RPM, Max BHP 2.9

High static – 838–1084 RPM, Max BHP 3.7

50TCQ

FAN PERFORMANCE (cont.)

Table 64 – 50TCQD14

12.5 TON HORIZONTAL SUPPLY

CFM	AVAILABLE EXTERNAL STATIC PRESSURE (IN. WG)									
	0.2		0.4		0.6		0.8		1.0	
	RPM	BHP	RPM	BHP	RPM	BHP	RPM	BHP	RPM	BHP
3750	381	0.53	452	0.74	520	0.98	584	1.26	645	1.56
4063	401	0.63	468	0.86	531	1.11	592	1.39	651	1.69
4375	421	0.75	484	0.99	544	1.25	601	1.53	657	1.85
4688	441	0.89	501	1.14	558	1.40	612	1.70	666	2.02
5000	462	1.04	519	1.30	573	1.58	625	1.88	675	2.21
5313	483	1.21	537	1.49	589	1.77	638	2.08	686	2.42
5625	504	1.40	556	1.69	605	1.99	653	2.31	699	2.65
5938	525	1.61	575	1.91	622	2.22	668	2.55	712	2.90
6250	546	1.84	595	2.15	640	2.48	684	2.82	726	3.17

Std static – 507–676 RPM, Max BHP 2.9

Med static – 634–833 RPM, Max BHP 2.9

High static – 792–971 RPM, 208V: Max BHP 5.0; 230V/460V: Max BHP 6.1; 575V: Max BHP 5.9

Bold Face requires standard static drive package with KR11HY153 (1VP34) motor pulley (338–507)

Italics requires high static drive package with KR11HY186 (1VM50) motor pulley (684–864)

50TCQ

CFM	AVAILABLE EXTERNAL STATIC PRESSURE (IN. WG)											
	1.2		1.4		1.6		1.8		1.9		2.0	
	RPM	BHP	RPM	BHP	RPM	BHP	RPM	BHP	RPM	BHP	RPM	BHP
3750	703	1.88	757	2.23	808	2.59	855	2.97	878	3.17	900	3.36
4063	707	2.03	760	2.38	810	2.75	857	3.14	880	3.34	902	3.55
4375	711	2.18	763	2.55	812	2.93	859	3.33	882	3.53	904	3.74
4688	717	2.36	767	2.73	815	3.12	862	3.52	884	3.73	906	3.94
5000	725	2.55	773	2.93	820	3.32	865	3.73	887	3.95	908	4.16
5313	734	2.77	780	3.15	825	3.55	869	3.96	890	4.18	912	4.40
5625	744	3.07	788	3.39	832	3.79	874	4.22	895	4.44	916	4.66
5938	755	3.27	798	3.65	840	4.06	881	4.49	901	4.71	921	4.94
6250	768	3.55	808	3.94	849	4.36	888	4.79	908	5.01	927	5.24

Std static – 507–676 RPM, Max BHP 2.9

Med static – 634–833 RPM, Max BHP 2.9

High static – 792–971 RPM, 208V: Max BHP 5.0; 230V/460V: Max BHP 6.1; 575V: Max BHP 5.9

Italics requires high static drive package with KR11HY186 (1VM50) motor pulley (684–864)

Table 65 – 50TCQD14

12.5 VERTICAL SUPPLY

CFM	AVAILABLE EXTERNAL STATIC PRESSURE (IN. WG)									
	0.2		0.4		0.6		0.8		1.0	
	RPM	BHP	RPM	BHP	RPM	BHP	RPM	BHP	RPM	BHP
3750	441	0.65	513	0.88	582	1.15	647	1.45	707	1.78
4063	466	0.78	533	1.03	598	1.30	660	1.61	718	1.95
4375	491	0.94	554	1.19	615	1.48	674	1.80	730	2.14
4688	517	1.11	576	1.38	634	1.68	690	2.00	744	2.36
5000	543	1.31	599	1.59	653	1.90	706	2.23	758	2.59
5313	570	1.54	622	1.82	674	2.14	724	2.48	774	2.85
5625	596	1.78	646	2.08	695	2.41	743	2.76	790	3.14
5938	623	2.06	671	2.37	717	2.71	763	3.07	808	3.45
6250	650	2.36	695	2.69	740	3.03	784	3.40	827	3.80

Std static – 507–676 RPM, Max BHP 2.9

Med static – 634–833 RPM, Max BHP 2.9

High static – 792–971 RPM, 208V: Max BHP 5.0; 230V/460V: Max BHP 6.1; 575V: Max BHP 5.9

Bold Face requires standard static drive package with KR11HY153 (1VP34) motor pulley (338–507)

Italics requires high static drive package with KR11HY186 (1VM50) motor pulley (684–864)

CFM	AVAILABLE EXTERNAL STATIC PRESSURE (IN. WG)											
	1.2		1.4		1.6		1.8		1.9		2.0	
	RPM	BHP	RPM	BHP	RPM	BHP	RPM	BHP	RPM	BHP	RPM	BHP
3750	764	2.12	816	2.48	866	2.86	912	3.24	935	3.44	956	3.64
4063	773	2.31	825	2.68	874	3.07	921	3.47	943	3.68	965	3.88
4375	784	2.51	835	2.90	883	3.30	929	3.72	951	3.93	973	4.14
4688	795	2.73	845	3.13	893	3.54	938	3.98	960	4.19	981	4.42
5000	808	2.98	856	3.38	903	3.81	947	4.25	969	4.48	990	4.71
5313	822	3.25	868	3.66	914	4.10	957	4.55	978	4.78	999	5.02
5625	837	3.54	882	3.96	925	4.41	968	4.87	989	5.11	1009	5.35
5938	852	3.86	896	4.30	938	4.75	980	5.22	1000	5.46	1020	5.71
6250	869	4.22	911	4.65	952	5.12	992	5.59	1012	5.84	1032	6.09

Std static – 507–676 RPM, Max BHP 2.9

Med static – 634–833 RPM, Max BHP 2.9

High static – 792–971 RPM, 208V: Max BHP 5.0; 230V/460V: Max BHP 6.1; 575V: Max BHP 5.9

Bold Face requires standard static drive package with KR11HY153 (1VP34) motor pulley (338–507)

Italics requires high static drive package with KR11HY186 (1VM50) motor pulley (684–864)

Underline requires high static drive package with KR11HY194 (1VP60) motor pulley (864–1061).

FAN PERFORMANCE (cont.)

Table 66 – PULLEY ADJUSTMENT - BELT DRIVE

UNIT		MOTOR/DRIVE COMBO	MOTOR PULLEY TURNS OPEN											5.5	6
			0	0.5	1	1.5	2	2.5	3	3.5	4	4.5	5		
04	3 phase	Medium Static	1251	1208	1165	1121	1078	1035	992	949	905	862	819	–	–
		High Static	1466	1423	1380	1337	1294	1251	1207	1164	1121	1078	1035	–	–
05	3 phase	Medium Static	1303	1265	1226	1188	1150	1112	1073	1035	997	958	920	–	–
		High Static	1466	1423	1380	1337	1294	1251	1207	1164	1121	1078	1035	–	–
06	3 phase	Medium Static	1380	1349	1317	1286	1254	1223	1192	1160	1129	1097	1066	–	–
		High Static	1639	1596	1553	1510	1467	1424	1380	1337	1294	1251	1208	–	–
07	3 phase	Standard Static	1192	1161	1129	1098	1066	1035	1004	972	941	909	878	–	–
		Medium Static	1380	1349	1317	1286	1254	1223	1192	1160	1129	1097	1066	–	–
		High Static	1639	1596	1553	1510	1467	1424	1380	1337	1294	1251	1208	–	–
08	3 phase	Standard Static	652	633	614	594	575	556	537	518	498	479	460	–	–
		Medium Static	838	813	789	764	739	715	690	665	640	616	591	–	–
		High Static	1084	1059	1035	1010	986	961	936	912	887	863	838	–	–
09	3 phase	Standard Static	652	633	614	594	575	556	537	518	498	479	460	–	–
		Medium Static	838	813	789	764	739	715	690	665	640	616	591	–	–
		High Static	1084	1059	1035	1010	986	961	936	912	887	863	838	–	–
12	3 phase	Standard Static	652	633	614	594	575	556	537	518	498	479	460	–	–
		Medium Static	838	813	789	764	739	715	690	665	640	616	591	–	–
		High Static	1084	1059	1035	1010	986	961	936	912	887	863	838	–	–
14	3 phase	Standard Static	676	659	642	625	608	592	575	558	541	524	507	*	*
		Medium Static	**	**	833	813	793	773	753	734	714	694	674	654	634
		High Static	**	**	971	953	935	917	899	882	864	846	828	810	792

NOTE: Do not adjust pulley further than 5 turns open.

■ – Factory settings

* Do not set motor pulley above 5 turns open for A or AX section belts

** Do not set motor pulley below 1 turn open for B or BX section belts

50TCQ

ELECTRICAL INFORMATION

Table 67 – 50TCQA04
SINGLE STAGE COOLING WITH SINGLE SPEED INDOOR FAN MOTOR

V-Ph-Hz	VOLTAGE RANGE		COMP (ea)		OFM (ea)		IFM		
	MIN	MAX	RLA	LRA	WATTS	FLA	TYPE	EFF at Full Load	FLA
208-1-60	187	253	17.9	112	190	0.9	DD-STD	78%	7.4
230-1-60	187	253	17.9	112	190	0.9	DD-STD	78%	7.4
208-3-60	187	253	13.2	88	190	0.9	DD-STD	78%	7.4
							MED	87%	5.2
							HIGH	87%	6.9
230-3-60	187	253	13.2	88	190	0.9	DD-STD	78%	7.4
							MED	87%	4.9
							HIGH	87%	6.7
460-3-60	414	506	6.0	44	190	0.5	DD-STD	78%	4.0
							MED	87%	2.5
							HIGH	87%	3.4
575-3-60	518	633	4.2	30	190	0.4	DD-STD	78%	4.0
							MED	72%	1.6
							HIGH	78%	2.0

See Legend and Notes for Tables 67 – 108 on Page 113.

Table 68 – 50TCQA05
SINGLE STAGE COOLING WITH SINGLE SPEED INDOOR FAN MOTOR

V-Ph-Hz	VOLTAGE RANGE		COMP (ea)		OFM (ea)		IFM		
	MIN	MAX	RLA	LRA	WATTS	FLA	TYPE	EFF at Full Load	FLA
208-1-60	187	253	21.8	117	325	1.5	DD-STD	78%	7.4
230-1-60	187	253	21.8	117	325	1.5	DD-STD	78%	7.4
208-3-60	187	253	13.7	83	325	1.5	DD-STD	78%	7.4
							MED	87%	5.2
							HIGH	87%	6.9
230-3-60	187	253	13.7	83	325	1.5	DD-STD	78%	7.4
							MED	87%	4.9
							HIGH	87%	6.7
460-3-60	414	506	6.2	41	325	0.8	DD-STD	78%	4.0
							MED	87%	2.5
							HIGH	87%	3.4
575-3-60	518	633	4.8	33	325	0.6	DD-STD	78%	4.0
							MED	72%	1.6
							HIGH	78%	2.0

See Legend and Notes for Tables 67 – 108 on Page 113.

Table 69 – 50TCQA06
SINGLE STAGE COOLING WITH SINGLE SPEED INDOOR FAN MOTOR

V-Ph-Hz	VOLTAGE RANGE		COMP (ea)		OFM (ea)		IFM		
	MIN	MAX	RLA	LRA	WATTS	FLA	TYPE	EFF at Full Load	FLA
208-1-60	187	253	26.2	134	325	1.5	DD-STD	84%	7.4
230-1-60	187	253	26.2	134	325	1.5	DD-STD	84%	7.4
208-3-60	187	253	15.6	110	325	1.5	DD-STD	84%	7.4
							MED	80%	5.2
							HIGH	81%	7.5
230-3-60	187	253	15.6	110	325	1.5	DD-STD	84%	7.4
							MED	80%	5.2
							HIGH	81%	7.5
460-3-60	414	506	7.7	52	325	0.8	DD-STD	84%	7.6
							MED	80%	2.6
							HIGH	81%	3.4
575-3-60	518	633	5.8	39	325	0.6	DD-STD	84%	4.0
							MED	80%	2.0
							HIGH	81%	2.8

See Legend and Notes for Tables 67 – 108 on Page 113.

50TCQ

ELECTRICAL INFORMATION (cont.)

Table 70 – 50TCQA07

SINGLE STAGE COOLING WITH SINGLE SPEED INDOOR FAN MOTOR

(Units Produced On or After 02/09/2015)

V-Ph-Hz	VOLTAGE RANGE		COMP (ea)		OFM (ea)		IFM		
	MIN	MAX	RLA	LRA	WATTS	FLA	TYPE	EFF at Full Load	FLA
208-3-60	187	253	19.6	136	325	1.5	STD	80%	5.2
							MED	81%	8.4
							HIGH	81%	8.4
230-3-60	187	253	19.6	136	325	1.5	STD	80%	4.9
							MED	81%	8.3
							HIGH	81%	8.3
460-3-60	414	506	8.2	66	325	0.8	STD	80%	2.5
							MED	81%	4.2
							HIGH	81%	4.2
575-3-60	518	633	6.6	55	325	0.6	STD	80%	1.6
							MED	81%	2.8
							HIGH	81%	2.8

See Legend and Notes for Tables 67–108 on Page 113.

(Units Produced on or Prior to 02/08/2015)

V-Ph-Hz	VOLTAGE RANGE		COMP (ea)		OFM (ea)		IFM		
	MIN	MAX	RLA	LRA	WATTS	FLA	TYPE	EFF at Full Load	FLA
208-3-60	187	253	19.0	123	325	1.5	STD	80%	5.2
							MED	81%	8.4
							HIGH	81%	8.4
230-3-60	187	253	19.0	123	325	1.5	STD	80%	4.9
							MED	81%	8.3
							HIGH	81%	8.3
460-3-60	414	506	9.7	62	325	0.8	STD	80%	2.5
							MED	81%	4.2
							HIGH	81%	4.2
575-3-60	518	633	7.4	50	325	0.6	STD	80%	1.6
							MED	81%	2.8
							HIGH	81%	2.8

See Legend and Notes for Tables 67–108 on Page 113.

Table 71 – 50TCQD08

2-STAGE COOLING WITH SINGLE SPEED INDOOR FAN MOTOR

V-Ph-Hz	VOLTAGE RANGE		COMP (Cir 1)		COMP (Cir 2)		OFM (ea)		IFM		
	MIN	MAX	RLA	LRA	RLA	LRA	WATTS	FLA	TYPE	EFF at Full Load	FLA
208-3-60	187	253	13.1	83	13.1	83	325	1.5	STD	80%	5.2
									MED	81%	8.4
									HIGH	81%	8.4
230-3-60	187	253	13.1	83	13.1	83	325	1.5	STD	80%	4.9
									MED	81%	8.3
									HIGH	81%	8.3
460-3-60	414	506	6.1	41	6.1	41	325	0.8	STD	80%	2.5
									MED	81%	4.2
									HIGH	81%	4.2
575-3-60	518	633	4.4	33	4.4	33	325	0.6	STD	80%	1.6
									MED	81%	2.8
									HIGH	81%	2.8

See Legend and Notes for Tables 67–108 on Page 113.

50TCQ

Table 72 – 50TCQD08

2-STAGE COOLING WITH 2-SPEED INDOOR FAN MOTOR

V-Ph-Hz	VOLTAGE RANGE		COMP 1		COMP 2		OFM (ea)		IFM		
	MIN	MAX	RLA	LRA	RLA	LRA	WATTS	FLA	TYPE	EFF at Full Load	FLA
208-3-60	187	253	13.1	83	13.1	83	325	1.5	STD	84%	5.8
							325	1.5	MED	85%	8.6
							325	1.5	HIGH	85%	8.6
230-3-60	187	253	13.1	83	13.1	83	325	1.5	STD	84%	5.6
							325	1.5	MED	85%	7.8
							325	1.5	HIGH	85%	7.8
460-3-60	414	506	6.1	41	6.1	41	325	0.8	STD	79%	2.9
							325	0.8	MED	85%	3.8
							325	0.8	HIGH	85%	3.8
575-3-60	518	633	4.4	33	4.4	33	325	0.6	STD	81%	2.8
							325	0.6	MED	84%	4.5
							325	0.6	HIGH	84%	4.5

See Legend and Notes for Tables 67 – 108 on Page 113.

Table 73 – 50TCQD09

2-STAGE COOLING WITH SINGLE SPEED INDOOR FAN MOTOR

(Units Produced On or After 02/09/2015)

V-Ph-Hz	VOLTAGE RANGE		COMP (Cir 1)		COMP (Cir 2)		OFM (ea)		IFM		
	MIN	MAX	RLA	LRA	RLA	LRA	WATTS	FLA	TYPE	EFF at Full Load	FLA
208-3-60	187	253	14.5	98	13.7	83	325	1.5	STD	80%	5.2
									MED	80%	8.4
									HIGH	80%	8.4
230-3-60	187	253	14.5	98	13.7	83	325	1.5	STD	80%	4.9
									MED	80%	8.3
									HIGH	80%	8.3
460-3-60	414	506	6.3	55	6.2	41	325	0.8	STD	80%	2.5
									MED	80%	4.2
									HIGH	80%	4.2
575-3-60	518	633	6.0	41	4.8	33	325	0.6	STD	80%	1.6
									MED	80%	2.8
									HIGH	81%	2.8

See Legend and Notes for Tables 67 – 108 on Page 113.

(Units Produced on or Prior to 02/08/2015)

V-Ph-Hz	VOLTAGE RANGE		COMP (Cir 1)		COMP (Cir 2)		OFM (ea)		IFM		
	MIN	MAX	RLA	LRA	RLA	LRA	WATTS	FLA	TYPE	EFF at Full Load	FLA
208-3-60	187	253	16.0	91	13.7	83	325	1.5	STD	90%	5.2
									MED	90%	8.4
									HIGH	90%	8.4
230-3-60	187	253	16.0	91	13.7	83	325	1.5	STD	90%	4.9
									MED	90%	8.3
									HIGH	90%	8.3
460-3-60	414	506	7.0	46	6.2	41	325	0.8	STD	90%	2.5
									MED	90%	4.2
									HIGH	90%	4.2
575-3-60	518	633	5.6	37	4.8	33	325	0.6	STD	90%	1.6
									MED	80%	2.8
									HIGH	80%	2.8

See Legend and Notes for Tables 67 – 108 on Page 113.

ELECTRICAL INFORMATION (cont.)

Table 74 – 50TCQD09

2-STAGE COOLING WITH 2-SPEED INDOOR FAN MOTOR

(Units Produced On or After 02/09/2015)

V-Ph-Hz	VOLTAGE RANGE		COMP 1		COMP 2		OFM (ea)		IFM		
	MIN	MAX	RLA	LRA	RLA	LRA	WATTS	FLA	TYPE	EFF at Full Load	FLA
208-3-60	187	253	14.5	98	13.7	83	325	1.5	STD	84%	5.8
							325	1.5	MED	85%	8.6
							325	1.5	HIGH	85%	8.6
230-3-60	187	253	14.5	98	13.7	83	325	1.5	STD	84%	5.6
							325	1.5	MED	85%	7.8
							325	1.5	HIGH	85%	7.8
460-3-60	414	506	6.3	55	6.2	41	325	0.8	STD	79%	2.9
							325	0.8	MED	85%	3.8
							325	0.8	HIGH	85%	3.8
575-3-60	518	633	6.0	41	4.8	33	325	0.6	STD	81%	2.8
							325	0.6	MED	84%	4.5
							325	0.6	HIGH	84%	4.5

See Legend and Notes for Tables 67 – 108 on Page 113.

(Units Produced on or Prior to 02/08/2015)

V-Ph-Hz	VOLTAGE RANGE		COMP 1		COMP 2		OFM (ea)		IFM		
	MIN	MAX	RLA	LRA	RLA	LRA	WATTS	FLA	TYPE	EFF at Full Load	FLA
208-3-60	187	253	16.0	91	13.7	83	325	1.5	STD	80%	5.8
							325	1.5	MED	90%	8.6
							325	1.5	HIGH	90%	8.6
230-3-60	187	253	16.0	91	13.7	83	325	1.5	STD	90%	5.6
							325	1.5	MED	90%	7.8
							325	1.5	HIGH	80%	7.8
460-3-60	414	506	7.0	46	6.2	41	325	0.8	STD	80%	2.9
							325	0.8	MED	90%	3.8
							325	0.8	HIGH	90%	3.8
575-3-60	518	633	5.6	37	4.8	33	325	0.6	STD	80%	2.8
							325	0.6	MED	80%	4.5
							325	0.6	HIGH	80%	4.5

See Legend and Notes for Tables 67 – 108 on Page 113.

Table 75 – 50TCQD12

2-STAGE COOLING WITH SINGLE SPEED INDOOR FAN MOTOR

V-Ph-Hz	VOLTAGE RANGE		COMP (Cir 1)		COMP (Cir 2)		OFM (ea)		IFM		
	MIN	MAX	RLA	LRA	RLA	LRA	WATTS	FLA	TYPE	EFF at Full Load	FLA
208-3-60	187	253	15.6	110	15.9	110	1070	6.2	STD	80%	6.9
									MED	80%	10.6
									HIGH	80%	13.6
230-3-60	187	253	15.6	110	15.9	110	1070	6.2	STD	80%	6.7
									MED	80%	10.6
									HIGH	80%	12.7
460-3-60	414	506	7.7	52	7.7	52	1070	3.1	STD	80%	3.4
									MED	80%	5.3
									HIGH	80%	6.4
575-3-60	518	633	5.8	39	5.7	39	1070	2.5	STD	80%	2
									MED	80%	2.8
									HIGH	81%	5.6

See Legend and Notes for Tables 67 – 108 on Page 113.

50TCQ

ELECTRICAL INFORMATION (cont.)

Table 76 – 50TCQD12
2-STAGE COOLING WITH 2-SPEED INDOOR FAN MOTOR

V-Ph-Hz	VOLTAGE RANGE		COMP 1		COMP 2		OFM (ea)		IFM		
	MIN	MAX	RLA	LRA	RLA	LRA	WATTS	FLA	TYPE	EFF at Full Load	FLA
208-3-60	187	253	15.6	110	15.9	110	1070	6.2	STD	77%	7.1
							1070	6.2	MED	82%	10.8
							1070	6.2	HIGH	84%	13.6
230-3-60	187	253	15.6	110	15.9	110	1070	6.2	STD	77%	6.8
							1070	6.2	MED	82%	9.8
							1070	6.2	HIGH	84%	12.7
460-3-60	414	506	7.7	52	7.7	52	1070	3.1	STD	77%	3.8
							1070	3.1	MED	82%	4.9
							1070	3.1	HIGH	84%	6.4
575-3-60	518	633	5.8	39	5.7	39	1070	2.5	STD	80%	3.5
							1070	2.5	MED	84%	4.5
							1070	2.5	HIGH	83%	6.2

See Legend and Notes for Tables 67 – 108 on Page 113.

Table 77 – 50TCQD14
2-STAGE COOLING WITH SINGLE SPEED INDOOR FAN MOTOR

V-Ph-Hz	VOLTAGE RANGE		COMP (Cir 1)		COMP (Cir 2)		OFM (ea)		IFM		
	MIN	MAX	RLA	LRA	RLA	LRA	WATTS	FLA	TYPE	EFF at Full Load	FLA
208-3-60	187	253	22.4	149	22.4	149	280	1.5	STD	90%	8.4
									MED	90%	8.4
									HIGH	90%	17
230-3-60	187	253	22.4	149	22.4	149	280	1.5	STD	90%	8.3
									MED	90%	8.3
									HIGH	90%	15
460-3-60	414	506	10.6	75	10.6	75	280	0.8	STD	90%	4.2
									MED	90%	4.2
									HIGH	80%	7.6
575-3-60	518	633	8.5	54	8.5	54	280	0.7	STD	80%	2.8
									MED	90%	2.8
									HIGH	90%	6.1

See Legend and Notes for Tables 67 – 108 on Page 113.

Table 78 – 50TCQD14
2-STAGE COOLING WITH 2-SPEED INDOOR FAN MOTOR

V-Ph-Hz	VOLTAGE RANGE		COMP 1		COMP 2		OFM (ea)		IFM		
	MIN	MAX	RLA	LRA	RLA	LRA	WATTS	FLA	TYPE	EFF at Full Load	FLA
208-3-60	187	253	22.4	149	22.4	149	280	1.5	STD	90%	8.6
							280	1.5	MED	90%	8.6
							280	1.5	HIGH	90%	20.4
230-3-60	187	253	22.4	149	22.4	149	280	1.5	STD	90%	7.8
							280	1.5	MED	90%	7.8
							280	1.5	HIGH	90%	20.4
460-3-60	414	506	10.6	75	10.6	75	280	0.8	STD	90%	3.8
							280	0.8	MED	90%	3.8
							280	0.8	HIGH	90%	10.2
575-3-60	518	633	8.5	54	8.5	54	280	0.7	STD	80%	4.5
							280	0.7	MED	80%	4.5
							280	0.7	HIGH	90%	9.0

See Legend and Notes for Tables 67 – 108 on Page 113.

50TCQ

MCA/MOCP

Table 79 – 50TCQA04

MCA/MOCP DETERMINATION NO C.O. OR UNPWRD C.O. SINGLE STAGE COOLING WITH SINGLE SPEED INDOOR FAN MOTOR

UNIT	NOM. V-PH-HZ	IFMTYPE	ELEC. HTR			NO C.O. or UNPWR C.O.							
			CRHEATER ****00	Nom (kW)	FLA	NO P.E.				w/ P.E. (pwrd fr/unit)			
						MCA	MAX FUSE or HACR BRKR	DISC. SIZE		MCA	MAX FUSE or HACR BRKR	DISC. SIZE	
								FLA	LRA			FLA	LRA
50TCQA04	208/230-1-60	DD-STD	NONE	-	-	31	45	30	121	-	-	-	-
			101A	3.3/4.4	15.9/18.3	51/54	60/60	48/51	137/139	-	-	-	-
			102A	4.9/6.5	23.5/27.1	61/65	70/70	57/61	145/148	-	-	-	-
			103B	6.5/8.7	31.4/36.3	70/77	70/80	66/72	152/157	-	-	-	-
			104B	7.9/10.5	37.9/43.8	79/86	80/90	74/81	159/165	-	-	-	-
			102A+102A	9.8/13.0	46.9/54.2	90/99	90/100	84/92	215/229	-	-	-	-
	208/230-3-60	DD-STD	NONE	-	-	25	30	25	97	27	30	27	99
			101A	3.3/4.4	9.2/10.6	37/39	45/45	35/37	106/108	39/40	45/50	37/39	108/110
			102A	4.9/6.5	13.6/15.6	42/45	50/50	40/43	111/113	44/47	50/50	43/45	113/115
			103B	6.5/8.7	18.1/20.9	48/51	50/60	46/49	115/118	50/53	50/60	48/51	117/120
			104B	7.9/10.5	21.9/25.3	53/57	60/60	50/54	119/122	55/59	60/60	52/56	121/124
			105A	12.0/16.0	33.4/38.5	67/73	70/80	63/69	130/136	69/75	70/80	65/71	132/138
		MED	NONE	-	-	23/23	30/30	22/22	126	25/25	30/30	24/24	128
			101A	3.3/4.4	9.2/10.6	35/36	45/45	33/34	135/137	36/38	45/45	35/36	137/139
			102A	4.9/6.5	13.6/15.6	40/42	45/50	38/40	140/142	42/44	50/50	40/42	142/144
			103B	6.5/8.7	18.1/20.9	46/49	50/50	43/46	144/147	48/51	50/60	45/48	146/149
			104B	7.9/10.5	21.9/25.3	50/54	50/60	47/51	148/151	52/56	60/60	50/53	150/153
			105A	12.0/16.0	33.4/38.5	65/71	70/80	61/66	159/165	67/73	70/80	63/68	161/167
		HIGH	NONE	-	-	25/25	30/30	24/24	147	27/26	30/30	26/26	149
			101A	3.3/4.4	9.2/10.6	36/38	45/45	35/36	156/158	38/40	45/45	37/38	158/160
			102A	4.9/6.5	13.6/15.6	42/44	50/50	40/42	161/163	44/46	50/50	42/44	163/165
			103B	6.5/8.7	18.1/20.9	47/51	50/60	45/48	165/168	49/53	50/60	47/50	167/170
			104B	7.9/10.5	21.9/25.3	52/56	60/60	49/53	169/172	54/58	60/60	52/55	171/174
			105A	12.0/16.0	33.4/38.5	67/73	70/80	63/68	180/186	68/75	70/80	65/70	182/188
	460-3-60	DD-STD	NONE	-	-	12	15	12	49	13	15	13	50
			106A	6.0	7.2	21	25	20	56	22	25	22	57
			107A	8.8	10.6	26	30	24	60	27	30	25	61
			108A	11.5	13.8	30	30	28	63	31	35	29	64
109A			14.0	16.8	33	35	31	66	34	35	33	67	
MED		NONE	-	-	11	15	10	63	12	15	12	64	
		106A	6.0	7.2	20	20	19	70	21	25	20	71	
		107A	8.8	10.6	24	25	23	74	25	25	24	75	
		108A	11.5	13.8	28	30	26	77	29	30	27	78	
		109A	14.0	16.8	32	35	30	80	33	35	31	81	
HIGH		NONE	-	-	12	15	11	73	13	15	13	74	
		106A	6.0	7.2	21	25	20	80	22	25	21	81	
	107A	8.8	10.6	25	25	24	84	26	30	25	85		
	108A	11.5	13.8	29	30	27	87	30	30	28	88		
	109A	14.0	16.8	33	35	31	90	34	35	32	91		
575-3-60	DD-STD	NONE	-	-	10	15	10	35	12	15	12	37	
	MED	NONE	-	-	8	15	7	38	10	15	9	40	
	HIGH	NONE	-	-	8	15	8	42	10	15	10	44	

50TCQ

See Legend and Notes for Tables 67 – 108 on Page 113.

MCA/MOCP (cont.)

Table 80 – 50TCQA05

**MCA/MOCP DETERMINATION NO C.O. OR UNPWRD C.O.
SINGLE STAGE COOLING WITH SINGLE SPEED INDOOR FAN MOTOR**

UNIT	NOM. V – PH – HZ	IFMTYPE	ELEC. HTR			NO C.O. or UNPWR C.O.							
			CRHEATER ****00	Nom (kW)	FLA	NO P.E.				w/ P.E. (pwrd fr/unit)			
						MCA	MAX FUSE or HACR BRKR	DISC. SIZE		MCA	MAX FUSE or HACR BRKR	DISC. SIZE	
								FLA	LRA			FLA	LRA
50TCQA05	208/230–1–60	DD–STD	NONE	–	–	37	50	35	128	–	–	–	–
			101A	3.3/4.4	15.9/18.3	56/59	60/60	54/56	144/146	–	–	–	–
			103B	6.5/8.7	31.4/36.3	76/82	80/90	71/77	159/164	–	–	–	–
			102A+102A	9.8/13.0	46.9/54.2	95/104	100/110	89/98	222/236	–	–	–	–
			103B+103B	13.1/17.4	62.8/72.5	115/127	125/150	108/119	254/273	–	–	–	–
	104B+104B	15.8/21.0	75.8/87.5	131/146	150/150	122/136	280/303	–	–	–	–		
	208/230–3–60	DD–STD	NONE	–	–	26	30	26	94	28	40	28	96
			102A	4.9/6.5	13.6/15.6	43/46	50/50	42/44	108/110	45/48	50/50	44/46	110/112
			103B	6.5/8.7	18.1/20.9	49/53	50/60	47/50	112/115	51/55	60/60	49/52	114/117
			105A	12.0/16.0	33.4/38.5	68/75	70/80	64/70	127/133	70/77	70/80	67/72	129/135
			104B+104B	15.8/21.0	43.8/50.5	81/90	90/90	76/84	182/195	83/92	90/100	79/86	184/197
		MED	NONE	–	–	24/24	30/30	23/23	123	26/26	30/30	26/25	125
			102A	4.9/6.5	13.6/15.6	41/43	50/50	39/41	137/139	43/45	50/50	41/43	139/141
			103B	6.5/8.7	18.1/20.9	47/50	50/50	44/47	141/144	49/52	50/60	46/49	143/146
			105A	12.0/16.0	33.4/38.5	66/72	70/80	62/67	156/162	68/74	70/80	64/70	158/164
			104B+104B	15.8/21.0	43.8/50.5	79/87	80/90	74/81	211/224	81/89	90/90	76/83	213/226
		HIGH	NONE	–	–	26/26	30/30	25/25	144	28/28	40/40	28/27	146
			102A	4.9/6.5	13.6/15.6	43/45	50/50	41/43	158/160	45/47	50/50	43/45	160/162
			103B	6.5/8.7	18.1/20.9	49/52	50/60	46/49	162/165	51/54	60/60	48/51	164/167
			105A	12.0/16.0	33.4/38.5	68/74	70/80	64/69	177/183	70/76	70/80	66/72	179/185
			104B+104B	15.8/21.0	43.8/50.5	81/89	90/90	76/83	232/245	83/91	90/100	78/85	234/247
	460–3–60	DD–STD	NONE	–	–	13	15	13	47	14	20	14	48
			106A	6.0	7.2	22	25	21	54	23	25	22	55
			108A	11.5	13.8	30	30	29	61	31	35	30	62
109A			14.0	16.8	34	35	32	64	35	35	33	65	
108A+108A			23.0	27.7	48	50	45	102	49	50	46	103	
MED		NONE	–	–	12	15	11	61	13	15	12	62	
		106A	6.0	7.2	21	25	19	68	22	25	20	69	
		108A	11.5	13.8	29	30	27	75	30	30	28	76	
		109A	14.0	16.8	33	35	30	78	34	35	31	79	
108A+108A		23.0	27.7	46	50	43	116	47	50	44	117		
HIGH		NONE	–	–	12	15	12	71	13	15	13	72	
		106A	6.0	7.2	21	25	20	78	22	25	21	79	
	108A	11.5	13.8	30	30	28	85	31	35	29	86		
	109A	14.0	16.8	33	35	31	88	34	35	32	89		
108A+108A	23.0	27.7	47	50	44	126	48	50	45	127			
575–3–60	DD–STD	NONE	–	–	11	15	11	39	13	15	13	41	
	MED	NONE	–	–	9	15	8	42	11	15	10	44	
	HIGH	NONE	–	–	9	15	9	46	11	15	11	48	

See Legend and Notes for Tables 67–108 on Page 113.

MCA/MOCP (cont.)

Table 81 – 50TCQA06

MCA/MOCP DETERMINATION NO C.O. OR UNPWRD C.O. SINGLE STAGE COOLING WITH SINGLE SPEED INDOOR FAN MOTOR

UNIT	NOM. V – PH – HZ	IFMTYPE	ELEC. HTR			NO C.O. or UNPWR C.O.								
			CRHEATER ****00	Nom (kW)	FLA	NO P.E.				w/ P.E. (pwrd fr/unit)				
						MCA	MAX FUSE or HACR BRKR	DISC. SIZE		MCA	MAX FUSE or HACR BRKR	DISC. SIZE		
								FLA	LRA			FLA	LRA	
50TCQA06	208/230 – 1 – 60	DD – STD	NONE	–	–	42	60	40	145	–	–	–	–	
			102A	4.9/6.5	23.5/27.1	71/76	80/80	67/72	169/172	–	–	–	–	
			103B	6.5/8.7	31.4/36.3	81/87	90/100	76/82	176/181	–	–	–	–	
			102A+102A	9.8/13.0	46.9/54.2	101/110	110/110	94/103	239/253	–	–	–	–	
			103B+103B	13.1/17.4	62.8/72.5	121/133	125/150	113/124	271/290	–	–	–	–	
			104B+104B	15.8/21.0	75.8/87.5	137/151	150/175	128/141	297/320	–	–	–	–	
	208/230 – 3 – 60	DD – STD	NONE	–	–	29	40	28	121	31	45	30	123	
			102A	4.9/6.5	13.6/15.6	46/48	50/50	44/46	135/137	48/50	50/60	46/48	137/139	
			104B	7.9/10.5	21.9/25.3	56/60	60/70	53/57	143/146	58/62	60/70	56/59	145/148	
			105A	12.0/16.0	33.4/38.5	71/77	80/80	67/72	154/160	73/79	80/80	69/75	156/162	
			104B+104B	15.8/21.0	43.8/50.5	84/92	90/100	79/86	209/222	86/94	90/100	81/88	211/224	
				104B+105A	19.9/26.5	55.2/63.8	98/109	100/110	92/102	231/249	100/111	100/125	94/104	233/251
		MED	NONE	–	–	28/28	40/40	28/27	171	30/30	45/45	30/30	173	
			102A	4.9/6.5	13.6/15.6	45/48	50/50	43/45	185/187	47/50	50/60	45/47	187/189	
			104B	7.9/10.5	21.9/25.3	56/60	60/60	53/56	193/196	58/62	60/70	55/59	195/198	
			105A	12.0/16.0	33.4/38.5	70/76	70/80	66/72	204/210	72/78	80/80	68/74	206/212	
			104B+104B	15.8/21.0	43.8/50.5	83/91	90/100	78/85	259/272	85/93	90/100	80/88	261/274	
				104B+105A	19.9/26.5	55.2/63.8	97/108	100/110	91/101	281/299	99/110	100/110	93/103	283/301
		HIGH	NONE	–	–	30/30	45/40	29/29	186	32/32	45/45	32/31	188	
			102A	4.9/6.5	13.6/15.6	47/49	50/60	45/47	200/202	49/51	60/60	47/49	202/204	
104B			7.9/10.5	21.9/25.3	57/61	60/70	55/58	208/211	59/63	60/70	57/60	210/213		
105A	12.0/16.0		33.4/38.5	72/78	80/80	68/73	219/225	74/80	80/80	70/76	221/227			
104B+104B	15.8/21.0		43.8/50.5	85/93	90/100	80/87	274/287	87/95	90/100	82/89	276/289			
		104B+105A	19.9/26.5	55.2/63.8	99/110	100/110	93/103	296/314	101/111	110/125	95/105	298/316		
460 – 3 – 60	DD – STD	NONE	–	–	15	20	14	58	16	20	16	59		
		106A	6.0	7.2	24	25	23	65	25	30	24	66		
		108A	11.5	13.8	32	35	30	72	33	35	31	73		
		109A	14.0	16.8	36	40	34	75	37	40	35	76		
		108A+108A	23.0	27.7	50	50	46	113	51	60	47	114		
			108A+109A	25.5	30.7	53	60	50	119	54	60	51	120	
	MED	NONE	–	–	14	20	14	82	15	20	15	83		
		106A	6.0	7.2	23	25	22	89	24	25	23	90		
		108A	11.5	13.8	32	35	30	96	33	35	31	97		
		109A	14.0	16.8	35	35	33	99	36	40	34	100		
		108A+108A	23.0	27.7	49	50	46	137	50	50	47	138		
			108A+109A	25.5	30.7	53	60	49	143	54	60	50	144	
HIGH	NONE	–	–	15	20	15	90	16	20	16	91			
	106A	6.0	7.2	24	25	23	97	25	30	24	98			
	108A	11.5	13.8	32	35	30	104	33	35	32	105			
	109A	14.0	16.8	36	40	34	107	37	40	35	108			
	108A+108A	23.0	27.7	50	50	46	145	51	60	48	146			
		108A+109A	25.5	30.7	53	60	50	151	54	60	51	152		
575 – 3 – 60	DD – STD	NONE	–	–	12	15	12	45	14	20	14	47		
	MED	NONE	–	–	10	15	10	52	12	15	12	54		
	HIGH	NONE	–	–	11	15	11	63	13	15	13	65		

50TCQ

See Legend and Notes for Tables 67 – 108 on Page 113.

MCA/MOCP (cont.)

Table 82 – 50TCQA07

MCA/MOCP DETERMINATION NO C.O. OR UNPWRD C.O. SINGLE STAGE COOLING WITH SINGLE SPEED INDOOR FAN MOTOR

(Units Produced On or After 02/09/2015)

UNIT	NOM. V – PH – HZ	IFMTYPE	ELEC. HTR			NO C.O. or UNPWR C.O.								
			CRHEATER ****00	Nom (kW)	FLA	NO P.E.				w/ P.E. (pwrd fr/unit)				
						MCA	MAX FUSE or HACR BRKR	DISC. SIZE		MCA	MAX FUSE or HACR BRKR	DISC. SIZE		
								FLA	LRA			FLA	LRA	
50TCQ	208/230 – 3 – 60	STD	NONE	–	–	32/31	50/50	30/30	176	34/33	50/50	32/32	178	
			102A	4.9/6.5	13.6/15.6	49/51	60/60	46/48	190/192	51/53	60/60	48/50	192/194	
			104B	7.9/10.5	21.9/25.3	59/63	60/70	55/59	198/201	61/65	70/70	58/61	200/203	
			105A	12.0/16.0	33.4/38.5	73/79	80/80	69/74	209/215	75/81	80/90	71/76	211/217	
			104B+104B	15.8/21.0	43.8/50.5	86/94	90/100	81/88	264/277	88/96	90/100	83/90	266/279	
			104B+105A	19.9/26.5	55.2/63.8	101/111	110/125	94/103	286/304	103/113	110/125	96/105	288/306	
		MED	NONE	–	–	35/35	50/50	34/34	212	37/37	50/50	36/36	214	
			102A	4.9/6.5	13.6/15.6	52/54	60/60	50/52	226/228	54/56	60/60	52/54	228/230	
			104B	7.9/10.5	21.9/25.3	62/66	70/70	59/63	234/237	64/68	70/80	61/65	236/239	
			105A	12.0/16.0	33.4/38.5	77/83	80/90	72/78	245/251	79/85	80/90	75/80	247/253	
			104B+104B	15.8/21.0	43.8/50.5	90/98	90/100	84/92	300/313	92/100	100/100	86/94	302/315	
			104B+105A	19.9/26.5	55.2/63.8	104/115	110/125	97/107	322/340	106/116	110/125	100/109	324/342	
		HIGH	NONE	–	–	35/35	50/50	34/34	212	37/37	50/50	36/36	214	
			102A	4.9/6.5	13.6/15.6	52/54	60/60	50/52	226/228	54/56	60/60	52/54	228/230	
			104B	7.9/10.5	21.9/25.3	62/66	70/70	59/63	234/237	64/68	70/80	61/65	236/239	
			105A	12.0/16.0	33.4/38.5	77/83	80/90	72/78	245/251	79/85	80/90	75/80	247/253	
			104B+104B	15.8/21.0	43.8/50.5	90/98	90/100	84/92	300/313	92/100	100/100	86/94	302/315	
			104B+105A	19.9/26.5	55.2/63.8	104/115	110/125	97/107	322/340	106/116	110/125	100/109	324/342	
	50TCQA07	460 – 3 – 60	STD	NONE	–	–	14	20	13	86	15	20	14	87
				106A	6.0	7.2	23	25	22	93	24	25	23	94
				108A	11.5	13.8	31	35	29	100	32	35	30	101
				109A	14.0	16.8	35	35	33	103	36	40	34	104
				108A+108A	23.0	27.7	49	50	45	141	50	50	46	142
				108A+109A	25.5	30.7	52	60	49	147	53	60	50	148
			MED	NONE	–	–	16	20	15	104	17	20	16	105
				106A	6.0	7.2	25	30	23	111	26	30	25	112
				108A	11.5	13.8	33	35	31	118	34	35	32	119
HIGH		NONE	–	–	16	20	15	104	17	20	16	105		
		106A	6.0	7.2	25	30	23	111	26	30	25	112		
		108A	11.5	13.8	33	35	31	118	34	35	32	119		
575 – 3 – 60		STD	NONE	–	–	11	15	10	64	13	15	12	66	
			MED	NONE	–	–	12	15	12	79	14	20	14	81
			HIGH	NONE	–	–	12	15	12	79	14	20	14	81

See Legend and Notes for Tables 67 – 108 on Page 113.

MCA/MOCP (cont.)

Table 83 – 50TCQA07

MCA/MOCP DETERMINATION NO C.O. OR UNPWRD C.O. SINGLE STAGE COOLING WITH SINGLE SPEED INDOOR FAN MOTOR

(Units Produced on or Prior to 02/08/2015)

UNIT	NOM. V – PH – HZ	IFMTYPE	ELEC. HTR			NO C.O. or UNPWR C.O.							
			CRHEATER ****00	Nom (kW)	FLA	NO P.E.				w/ P.E. (pwrd fr/unit)			
						MCA	MAX FUSE or HACR BRKR	DISC. SIZE		MCA	MAX FUSE or HACR BRKR	DISC. SIZE	
								FLA	LRA			FLA	LRA
50TCQA07	208/230 – 3 – 60	STD	NONE	–	–	31/31	45/45	30/29	163	33/33	50/50	32/31	165
			102A	4.9/6.5	13.6/15.6	48/50	60/60	45/47	177/179	50/52	60/60	47/49	179/181
			104B	7.9/10.5	21.9/25.3	58/62	60/70	55/58	185/188	60/64	60/70	57/60	187/190
			105A	12.0/16.0	33.4/38.5	73/79	80/80	68/73	196/202	75/81	80/90	70/76	198/204
			104B+104B	15.8/21.0	43.8/50.5	86/94	90/100	80/87	251/264	88/96	90/100	82/89	253/266
			104B+105A	19.9/26.5	55.2/63.8	100/110	100/110	93/103	273/291	102/112	110/125	95/105	275/293
		MED	NONE	–	–	34/34	50/50	33/33	199	36/36	50/50	35/35	201
			102A	4.9/6.5	13.6/15.6	51/54	60/60	49/51	213/215	53/55	60/60	51/53	215/217
			104B	7.9/10.5	21.9/25.3	61/66	70/70	58/62	221/224	63/68	70/70	61/64	223/226
			105A	12.0/16.0	33.4/38.5	76/82	80/90	72/77	232/238	78/84	80/90	74/80	234/240
			104B+104B	15.8/21.0	43.8/50.5	89/97	90/100	84/91	287/300	91/99	100/100	86/93	289/302
			104B+105A	19.9/26.5	55.2/63.8	103/114	110/125	97/106	309/327	105/116	110/125	99/109	311/329
	HIGH	NONE	–	–	34/34	50/50	33/33	199	36/36	50/50	35/35	201	
		102A	4.9/6.5	13.6/15.6	51/54	60/60	49/51	213/215	53/55	60/60	51/53	215/217	
		104B	7.9/10.5	21.9/25.3	61/66	70/70	58/62	221/224	63/68	70/70	61/64	223/226	
		105A	12.0/16.0	33.4/38.5	76/82	80/90	72/77	232/238	78/84	80/90	74/80	234/240	
		104B+104B	15.8/21.0	43.8/50.5	89/97	90/100	84/91	287/300	91/99	100/100	86/93	289/302	
		104B+105A	19.9/26.5	55.2/63.8	103/114	110/125	97/106	309/327	105/116	110/125	99/109	311/329	
	460 – 3 – 60	STD	NONE	–	–	16	25	15	82	17	25	16	83
			106A	6.0	7.2	25	30	23	89	26	30	24	90
			108A	11.5	13.8	33	35	31	96	34	35	32	97
			109A	14.0	16.8	37	40	34	99	38	40	35	100
			108A+108A	23.0	27.7	51	60	47	137	52	60	48	138
			108A+109A	25.5	30.7	54	60	50	143	55	60	51	144
MED		NONE	–	–	18	25	17	100	19	25	18	101	
		106A	6.0	7.2	27	30	25	107	28	30	26	108	
		108A	11.5	13.8	35	40	33	114	36	40	34	115	
		109A	14.0	16.8	39	40	36	117	40	40	37	118	
		108A+108A	23.0	27.7	52	60	49	155	53	60	50	156	
		108A+109A	25.5	30.7	56	60	52	161	57	60	53	162	
HIGH		NONE	–	–	18	25	17	100	19	25	18	101	
		106A	6.0	7.2	27	30	25	107	28	30	26	108	
		108A	11.5	13.8	35	40	33	114	36	40	34	115	
		109A	14.0	16.8	39	40	36	117	40	40	37	118	
		108A+108A	23.0	27.7	52	60	49	155	53	60	50	156	
		108A+109A	25.5	30.7	56	60	52	161	57	60	53	162	
575 – 3 – 60	STD	NONE	–	–	12	15	11	59	14	20	13	61	
	MED	NONE	–	–	13	20	12	74	15	20	15	76	
	HIGH	NONE	–	–	13	20	12	74	15	20	15	76	

50TCQ

See Legend and Notes for Tables 67 – 108 on Page 113.

MCA/MOCP (cont.)

Table 84 – 50TCQD08

MCA/MOCP DETERMINATION NO C.O. OR UNPWRD C.O. 2-STAGE COOLING WITH SINGLE SPEED INDOOR FAN MOTOR

UNIT	NOM. V – PH – HZ	IFM TYPE	ELEC. HTR			NO C.O. or UNPWR C.O.							
			CRHEATER ****00	Nom (kW)	FLA	NO P.E.				w/ P.E. (pwrd fr/unit)			
						MCA	MAX FUSE or HACR BRKR	DISC. SIZE		MCA	MAX FUSE or HACR BRKR	DISC. SIZE	
								FLA	LRA			FLA	LRA
50TCQ	208/230 – 3 – 60	STD	NONE	–	–	38/38	50/50	40/39	210	42/42	50/50	44/44	214
			117A	7.8/10.4	21.7/25.0	65/69	70/70	65/68	232/235	69/73	70/80	69/72	236/239
			110A	12.0/16.0	33.4/38.5	80/86	80/90	78/83	243/249	84/90	90/90	82/88	247/253
			111A	18.6/24.8	51.7/59.7	103/112	110/125	99/108	262/270	107/116	110/125	103/112	266/274
			112A	24.0/32.0	66.7/77.0	122/134	125/150	116/128	277/287	125/138	125/150	121/132	281/291
		112A+117A	31.8/42.4	88.4/102.0	149/165	150/175	141/157	387/414	152/169	175/175	146/161	391/418	
		MED	NONE	–	–	41/41	50/50	43/43	246	45/45	50/50	48/47	250
			117A	7.8/10.4	21.7/25.0	68/72	70/80	68/72	268/271	72/76	80/80	73/76	272/275
			110A	12.0/16.0	33.4/38.5	83/89	90/90	82/87	279/285	87/93	90/100	86/92	283/289
			111A	18.6/24.8	51.7/59.7	106/116	110/125	103/112	298/306	110/120	110/125	107/116	302/310
			112A	24.0/32.0	66.7/77.0	125/137	125/150	120/132	313/323	129/141	150/150	124/136	317/327
		112A+117A	31.8/42.4	88.4/102.0	152/169	175/175	145/160	423/450	156/173	175/175	149/165	427/454	
		HIGH	NONE	–	–	41/41	50/50	43/43	246	45/45	50/50	48/47	250
			117A	7.8/10.4	21.7/25.0	68/72	70/80	68/72	268/271	72/76	80/80	73/76	272/275
			110A	12.0/16.0	33.4/38.5	83/89	90/90	82/87	279/285	87/93	90/100	86/92	283/289
	111A		18.6/24.8	51.7/59.7	106/116	110/125	103/112	298/306	110/120	110/125	107/116	302/310	
	112A		24.0/32.0	66.7/77.0	125/137	125/150	120/132	313/323	129/141	150/150	124/136	317/327	
	112A+117A	31.8/42.4	88.4/102.0	152/169	175/175	145/160	423/450	156/173	175/175	149/165	427/454		
50TCQD08	460 – 3 – 60	STD	NONE	–	–	18	20	19	104	20	25	21	106
			116A	13.9	16.7	39	40	38	121	41	45	40	123
			113A	16.5	19.8	43	45	42	124	45	45	44	126
			114A	27.8	33.4	60	60	57	137	62	70	59	139
			115A	33.0	39.7	68	70	64	144	70	70	66	146
		114A+116A	41.7	50.2	81	90	76	204	83	90	79	206	
	MED	NONE	–	–	20	25	21	122	22	25	23	124	
		116A	13.9	16.7	41	45	40	139	43	45	42	141	
		113A	16.5	19.8	45	45	43	142	47	50	46	144	
		114A	27.8	33.4	62	70	59	155	64	70	61	157	
		115A	33.0	39.7	70	70	66	162	71	80	68	164	
	114A+116A	41.7	50.2	83	90	78	222	85	90	81	224		
	HIGH	NONE	–	–	20	25	21	122	22	25	23	124	
		116A	13.9	16.7	41	45	40	139	43	45	42	141	
		113A	16.5	19.8	45	45	43	142	47	50	46	144	
114A		27.8	33.4	62	70	59	155	64	70	61	157		
115A		33.0	39.7	70	70	66	162	71	80	68	164		
114A+116A	41.7	50.2	83	90	78	222	85	90	81	224			
575 – 3 – 60	STD	NONE	–	–	13	15	13	77	17	20	18	81	
		118A	17.0	20.4	39	40	37	97	42	45	41	101	
		119A	34.0	40.9	64	70	60	118	68	70	65	122	
	MED	NONE	–	–	14	20	15	92	18	20	19	96	
		118A	17.0	20.4	40	40	38	112	44	45	43	116	
		119A	34.0	40.9	65	70	62	133	69	70	66	137	
	HIGH	NONE	–	–	14	20	15	92	18	20	19	96	
		118A	17.0	20.4	40	40	38	112	44	45	43	116	
		119A	34.0	40.9	65	70	62	133	69	70	66	137	

See Legend and Notes for Tables 67 – 108 on Page 113.

MCA/MOCP (cont.)

Table 85 – 50TCQD08

MCA/MOCP DETERMINATION NO C.O. OR UNPWRD C.O. 2-STAGE COOLING WITH 2-SPEED INDOOR FAN MOTOR

UNIT	NOM. V – PH – HZ	IFM TYPE	ELEC. HTR			NO C.O. or UNPWR C.O.							
			CRHEATER ****00	Nom (kW)	FLA	NO P.E.				w/ P.E. (pwrdr fr/unit)			
						MCA	MAX FUSE or HACR BRKR	DISC. SIZE		MCA	MAX FUSE or HACR BRKR	DISC. SIZE	
								FLA	LRA			FLA	LRA
50TCQD08	208/230 – 3 – 60	STD	NONE	–	–	39/39	50/50	40/40	197	43/42	50/50	45/44	201
			117A	7.8/10.4	21.7/25.0	66/70	70/70	65/69	219/222	70/74	70/80	70/73	223/226
			110A	12.0/16.0	33.4/38.5	80/87	90/90	79/84	230/236	84/90	90/90	83/89	234/240
			111A	18.6/24.8	51.7/59.7	103/113	110/125	100/109	249/257	107/117	110/125	104/113	253/261
			112A	24.0/32.0	66.7/77.0	122/135	125/150	117/129	264/274	126/139	150/150	121/133	268/278
		112A+117A	31.8/42.4	88.4/102.0	149/166	150/175	142/157	374/401	153/170	175/175	146/162	378/405	
		MED	NONE	–	–	42/41	50/50	43/43	227	45/45	50/50	48/47	231
			117A	7.8/10.4	21.7/25.0	69/72	70/80	68/71	249/252	72/76	80/80	73/76	253/256
			110A	12.0/16.0	33.4/38.5	83/89	90/90	82/87	260/266	87/93	90/100	86/91	264/270
	111A		18.6/24.8	51.7/59.7	106/115	110/125	103/111	279/287	110/119	110/125	107/116	283/291	
	112A		24.0/32.0	66.7/77.0	125/137	125/150	120/131	294/304	129/141	150/150	125/135	298/308	
	112A+117A	31.8/42.4	88.4/102.0	152/168	175/175	145/160	404/431	156/172	175/175	150/164	408/435		
	HIGH	NONE	–	–	42/41	50/50	43/43	227	45/45	50/50	48/47	231	
		117A	7.8/10.4	21.7/25.0	69/72	70/80	68/71	249/252	72/76	80/80	73/76	253/256	
		110A	12.0/16.0	33.4/38.5	83/89	90/90	82/87	260/266	87/93	90/100	86/91	264/270	
		111A	18.6/24.8	51.7/59.7	106/115	110/125	103/111	279/287	110/119	110/125	107/116	283/291	
		112A	24.0/32.0	66.7/77.0	125/137	125/150	120/131	294/304	129/141	150/150	125/135	298/308	
	112A+117A	31.8/42.4	88.4/102.0	152/168	175/175	145/160	404/431	156/172	175/175	150/164	408/435		
460 – 3 – 60	STD	NONE	–	–	19	20	19	97	20	25	21	99	
		116A	13.9	16.7	40	40	38	114	41	45	40	116	
		113A	16.5	19.8	43	45	42	117	45	45	44	119	
		114A	27.8	33.4	60	60	58	130	62	70	60	132	
		115A	33.0	39.7	68	70	65	137	70	70	67	139	
	114A+116A	41.7	50.2	81	90	77	197	83	90	79	199		
	MED	NONE	–	–	20	25	20	113	21	25	22	115	
		116A	13.9	16.7	40	40	39	130	42	45	42	132	
		113A	16.5	19.8	44	45	43	133	46	50	45	135	
114A		27.8	33.4	61	70	59	146	63	70	61	148		
115A		33.0	39.7	69	70	66	153	71	80	68	155		
114A+116A	41.7	50.2	82	90	78	213	84	90	80	215			
HIGH	NONE	–	–	20	25	20	113	21	25	22	115		
	116A	13.9	16.7	40	40	39	130	42	45	42	132		
	113A	16.5	19.8	44	45	43	133	46	50	45	135		
	114A	27.8	33.4	61	70	59	146	63	70	61	148		
	115A	33.0	39.7	69	70	66	153	71	80	68	155		
114A+116A	41.7	50.2	82	90	78	213	84	90	80	215			
575 – 3 – 60	STD	NONE	–	–	14	20	15	79	18	20	19	83	
		118A	17.0	20.4	40	40	38	99	44	45	43	103	
		119A	34.0	40.9	65	70	62	120	69	70	66	124	
	MED	NONE	–	–	16	20	17	92	20	25	21	96	
		118A	17.0	20.4	42	45	40	112	45	45	45	116	
		119A	34.0	40.9	67	70	64	133	71	80	68	137	
	HIGH	NONE	–	–	16	20	17	92	20	25	21	96	
		118A	17.0	20.4	42	45	40	112	45	45	45	116	
		119A	34.0	40.9	67	70	64	133	71	80	68	137	

50TCQ

See Legend and Notes for Tables 67 – 108 on Page 113.

MCA/MOCP (cont.)

Table 86 – 50TCQD09

MCA/MOCP DETERMINATION NO C.O. OR UNPWRD C.O. 2-STAGE COOLING WITH SINGLE SPEED INDOOR FAN MOTOR

(Units Produced On or After 02/09/2015)

UNIT	NOM. V-PH-HZ	IFM TYPE	ELEC. HTR			NO C.O. or UNPWR C.O.							
			CRHEATER ****00	Nom (kW)	FLA	NO P.E.				w/ P.E. (pwrd fr/unit)			
						MCA	MAX FUSE or HACR BRKR	DISC. SIZE		MCA	MAX FUSE or HACR BRKR	DISC. SIZE	
								FLA	LRA			FLA	LRA
50TCQ	208/230-3-60	STD	NONE	-	-	40/40	50/50	42/42	225	44/44	50/50	46/46	229
			117A	7.8/10.4	21.7/25.0	68/71	70/80	67/70	247/250	71/75	80/80	71/75	251/254
			110A	12.0/16.0	33.4/38.5	82/88	90/90	80/86	258/264	86/92	90/100	85/90	262/268
			111A	18.6/24.8	51.7/59.7	105/115	110/125	101/110	277/285	109/119	110/125	106/115	281/289
			112A	24.0/32.0	66.7/77.0	124/136	125/150	119/130	292/302	128/140	150/150	123/134	296/306
			112A+117A	31.8/42.4	88.4/102.0	151/168	175/175	144/159	402/429	155/171	175/175	148/163	406/433
		MED	NONE	-	-	44/44	50/50	46/45	261	47/47	60/60	50/50	265
			117A	7.8/10.4	21.7/25.0	71/75	80/80	70/74	283/286	75/79	80/80	75/79	287/290
			110A	12.0/16.0	33.4/38.5	85/92	90/100	84/90	294/300	89/96	90/100	88/94	298/304
			111A	18.6/24.8	51.7/59.7	108/118	110/125	105/114	313/321	112/122	125/125	109/118	317/325
			112A	24.0/32.0	66.7/77.0	127/140	150/150	122/134	328/338	131/144	150/150	127/138	332/342
			112A+117A	31.8/42.4	88.4/102.0	154/171	175/175	147/163	438/465	158/175	175/175	152/167	442/469
		HIGH	NONE	-	-	44/44	50/50	46/45	261	47/47	60/60	50/50	265
			117A	7.8/10.4	21.7/25.0	71/75	80/80	70/74	283/286	75/79	80/80	75/79	287/290
			110A	12.0/16.0	33.4/38.5	85/92	90/100	84/90	294/300	89/96	90/100	88/94	298/304
	111A		18.6/24.8	51.7/59.7	108/118	110/125	105/114	313/321	112/122	125/125	109/118	317/325	
	112A		24.0/32.0	66.7/77.0	127/140	150/150	122/134	328/338	131/144	150/150	127/138	332/342	
	112A+117A		31.8/42.4	88.4/102.0	154/171	175/175	147/163	438/465	158/175	175/175	152/167	442/469	
50TCQD09	460-3-60	STD	NONE	-	-	19	20	19	118	20	25	21	120
			116A	13.9	16.7	40	40	38	135	41	45	40	137
			113A	16.5	19.8	43	45	42	138	45	45	44	140
			114A	27.8	33.4	60	60	58	151	62	70	60	153
			115A	33.0	39.7	68	70	65	158	70	70	67	160
			114A+116A	41.7	50.2	81	90	77	218	83	90	79	220
		MED	NONE	-	-	20	25	21	136	22	25	23	138
			116A	13.9	16.7	41	45	40	153	43	45	42	155
			113A	16.5	19.8	45	45	44	156	47	50	46	158
	HIGH	114A	27.8	33.4	62	70	59	169	64	70	62	171	
		115A	33.0	39.7	70	70	67	176	72	80	69	178	
		114A+116A	41.7	50.2	83	90	79	236	85	90	81	238	
		NONE	-	-	20	25	21	136	22	25	23	138	
		116A	13.9	16.7	41	45	40	153	43	45	42	155	
		113A	16.5	19.8	45	45	44	156	47	50	46	158	
	575-3-60	STD	114A	27.8	33.4	62	70	59	169	64	70	62	171
			115A	33.0	39.7	70	70	67	176	72	80	69	178
			114A+116A	41.7	50.2	83	90	79	236	85	90	81	238
MED		NONE	-	-	17	20	17	100	21	25	21	104	
		118A	17.0	20.4	42	45	40	120	46	50	45	124	
		119A	34.0	40.9	68	70	64	141	72	80	68	145	
HIGH		NONE	-	-	17	20	17	100	21	25	21	104	
		118A	17.0	20.4	42	45	40	120	46	50	45	124	
		119A	34.0	40.9	68	70	64	141	72	80	68	145	

See Legend and Notes for Tables 67 – 108 on Page 113.

MCA/MOCP (cont.)

Table 87 – 50TCQD09

MCA/MOCP DETERMINATION NO C.O. OR UNPWRD C.O. 2-STAGE COOLING WITH SINGLE SPEED INDOOR FAN MOTOR

(Units Produced on or Prior to 02/08/2015)

UNIT	NOM. V-PH-HZ	IFM TYPE	ELEC. HTR			NO C.O. or UNPWR C.O.							
			CRHEATER ****00	Nom (kW)	FLA	NO P.E.				w/ P.E. (pwrd fr/unit)			
						MCA	MAX FUSE or HACR BRKR	DISC. SIZE		MCA	MAX FUSE or HACR BRKR	DISC. SIZE	
								FLA	LRA			FLA	LRA
50TCQD09	208/230-3-60	STD	NONE	-	-	40/40	50/50	42/42	225	44/44	50/50	46/46	229
			117A	7.8/10.4	21.7/25.0	68/71	70/80	67/70	247/250	71/75	80/80	71/75	251/254
			110A	12.0/16.0	33.4/38.5	82/88	90/90	80/86	258/264	86/92	90/100	85/90	262/268
			111A	18.6/24.8	51.7/59.7	105/115	110/125	101/110	277/285	109/119	110/125	106/115	281/289
			112A	24.0/32.0	66.7/77.0	124/136	125/150	119/130	292/302	128/140	150/150	123/134	296/306
			112A+117A	31.8/42.4	88.4/102.0	151/168	175/175	144/159	402/429	155/171	175/175	148/163	406/433
		MED	NONE	-	-	44/44	50/50	46/45	261	47/47	60/60	50/50	265
			117A	7.8/10.4	21.7/25.0	71/75	80/80	70/74	283/286	75/79	80/80	75/79	287/290
			110A	12.0/16.0	33.4/38.5	85/92	90/100	84/90	294/300	89/96	90/100	88/94	298/304
			111A	18.6/24.8	51.7/59.7	108/118	110/125	105/114	313/321	112/122	125/125	109/118	317/325
			112A	24.0/32.0	66.7/77.0	127/140	150/150	122/134	328/338	131/144	150/150	127/138	332/342
			112A+117A	31.8/42.4	88.4/102.0	154/171	175/175	147/163	438/465	158/175	175/175	152/167	442/469
		HIGH	NONE	-	-	44/44	50/50	46/45	261	47/47	60/60	50/50	265
			117A	7.8/10.4	21.7/25.0	71/75	80/80	70/74	283/286	75/79	80/80	75/79	287/290
			110A	12.0/16.0	33.4/38.5	85/92	90/100	84/90	294/300	89/96	90/100	88/94	298/304
	111A		18.6/24.8	51.7/59.7	108/118	110/125	105/114	313/321	112/122	125/125	109/118	317/325	
	112A		24.0/32.0	66.7/77.0	127/140	150/150	122/134	328/338	131/144	150/150	127/138	332/342	
	112A+117A		31.8/42.4	88.4/102.0	154/171	175/175	147/163	438/465	158/175	175/175	152/167	442/469	
50TCQD09	460-3-60	STD	NONE	-	-	19	20	19	118	20	25	21	120
			116A	13.9	16.7	40	40	38	135	41	45	40	137
			113A	16.5	19.8	43	45	42	138	45	45	44	140
			114A	27.8	33.4	60	60	58	151	62	70	60	153
			115A	33.0	39.7	68	70	65	158	70	70	67	160
			114A+116A	41.7	50.2	81	90	77	218	83	90	79	220
		MED	NONE	-	-	20	25	21	136	22	25	23	138
			116A	13.9	16.7	41	45	40	153	43	45	42	155
			113A	16.5	19.8	45	45	44	156	47	50	46	158
	HIGH	NONE	-	-	20	25	21	136	22	25	23	138	
		116A	13.9	16.7	41	45	40	153	43	45	42	155	
		113A	16.5	19.8	45	45	44	156	47	50	46	158	
		114A	27.8	33.4	62	70	59	169	64	70	62	171	
		115A	33.0	39.7	70	70	67	176	72	80	69	178	
		114A+116A	41.7	50.2	83	90	79	236	85	90	81	238	
50TCQD09	STD	NONE	-	-	16	20	16	85	19	25	20	89	
		118A	17.0	20.4	41	45	39	105	45	45	43	109	
		119A	34.0	40.9	67	70	63	126	70	80	67	130	
	MED	NONE	-	-	17	20	17	100	21	25	21	104	
		118A	17.0	20.4	42	45	40	120	46	50	45	124	
		119A	34.0	40.9	68	70	64	141	72	80	68	145	
	HIGH	NONE	-	-	17	20	17	100	21	25	21	104	
		118A	17.0	20.4	42	45	40	120	46	50	45	124	
		119A	34.0	40.9	68	70	64	141	72	80	68	145	

50TCQ

See Legend and Notes for Tables 67 – 108 on Page 113.

MCA/MOCP (cont.)

Table 88 – 50TCQD09

**MCA/MOCP DETERMINATION NO C.O. OR UNPWRD C.O.
2-STAGE COOLING WITH 2-SPEED INDOOR FAN MOTOR**

(Units Produced On or After 02/09/2015)

UNIT	NOM. V-PH-HZ	IFM TYPE	ELEC. HTR			NO C.O. or UNPWR C.O.							
			CRHEATER ****00	Nom (kW)	FLA	NO P.E.				w/ P.E. (pwrd fr/unit)			
						MCA	MAX FUSE or HACR BRKR	DISC. SIZE		MCA	MAX FUSE or HACR BRKR	DISC. SIZE	
								FLA	LRA			FLA	LRA
50TCQ	208/230-3-60	STD	NONE	–	–	41/41	50/50	43/42	212	45/45	50/50	47/47	216
			117A	7.8/10.4	21.7/25.0	68/72	70/80	68/71	234/237	72/76	80/80	72/75	238/241
			110A	12.0/16.0	33.4/38.5	83/89	90/90	81/87	245/251	87/93	90/100	85/91	249/255
			111A	18.6/24.8	51.7/59.7	106/116	110/125	102/111	264/272	110/119	110/125	106/115	268/276
			112A	24.0/32.0	66.7/77.0	124/137	125/150	119/131	279/289	128/141	150/150	124/135	283/293
			112A+117A	31.8/42.4	88.4/102.0	152/168	175/175	144/160	389/416	155/172	175/175	149/164	393/420
		MED	NONE	–	–	44/43	50/50	46/45	242	48/47	60/60	50/49	246
			117A	7.8/10.4	21.7/25.0	71/74	80/80	71/74	264/267	75/78	80/80	75/78	268/271
			110A	12.0/16.0	33.4/38.5	86/91	90/100	84/89	275/281	89/95	90/100	89/93	279/285
			111A	18.6/24.8	51.7/59.7	109/118	110/125	105/114	294/302	112/122	125/125	110/118	298/306
			112A	24.0/32.0	66.7/77.0	127/139	150/150	122/133	309/319	131/143	150/150	127/138	313/323
			112A+117A	31.8/42.4	88.4/102.0	154/171	175/175	147/162	419/446	158/174	175/175	152/167	423/450
		HIGH	NONE	–	–	44/43	50/50	46/45	242	48/47	60/60	50/49	246
			117A	7.8/10.4	21.7/25.0	71/74	80/80	71/74	264/267	75/78	80/80	75/78	268/271
			110A	12.0/16.0	33.4/38.5	86/91	90/100	84/89	275/281	89/95	90/100	89/93	279/285
			111A	18.6/24.8	51.7/59.7	109/118	110/125	105/114	294/302	112/122	125/125	110/118	298/306
			112A	24.0/32.0	66.7/77.0	127/139	150/150	122/133	309/319	131/143	150/150	127/138	313/323
			112A+117A	31.8/42.4	88.4/102.0	154/171	175/175	147/162	419/446	158/174	175/175	152/167	423/450
50TCQD09	460-3-60	STD	NONE	–	–	19	25	20	111	21	25	22	113
			116A	13.9	16.7	40	40	39	128	42	45	41	130
			113A	16.5	19.8	44	45	42	131	46	50	44	133
			114A	27.8	33.4	61	70	58	144	63	70	60	146
			115A	33.0	39.7	69	70	65	151	70	80	67	153
			114A+116A	41.7	50.2	82	90	77	211	84	90	79	213
		MED	NONE	–	–	20	25	21	127	22	25	23	129
			116A	13.9	16.7	41	45	40	144	43	45	42	146
			113A	16.5	19.8	45	45	43	147	46	50	45	149
			114A	27.8	33.4	62	70	59	160	63	70	61	162
			115A	33.0	39.7	70	70	66	167	71	80	68	169
			114A+116A	41.7	50.2	83	90	78	227	84	90	80	229
		HIGH	NONE	–	–	20	25	21	127	22	25	23	129
			116A	13.9	16.7	41	45	40	144	43	45	42	146
			113A	16.5	19.8	45	45	43	147	46	50	45	149
			114A	27.8	33.4	62	70	59	160	63	70	61	162
			115A	33.0	39.7	70	70	66	167	71	80	68	169
			114A+116A	41.7	50.2	83	90	78	227	84	90	80	229
575-3-60	STD	NONE	–	–	17	20	17	87	21	25	21	91	
		118A	17.0	20.4	42	45	40	107	46	50	45	111	
		119A	34.0	40.9	68	70	64	128	72	80	68	132	
	MED	NONE	–	–	18	20	19	100	22	25	23	104	
		118A	17.0	20.4	44	45	42	120	48	50	47	124	
		119A	34.0	40.9	70	70	66	141	73	80	70	145	
	HIGH	NONE	–	–	18	20	19	100	22	25	23	104	
		118A	17.0	20.4	44	45	42	120	48	50	47	124	
		119A	34.0	40.9	70	70	66	141	73	80	70	145	

See Legend and Notes for Tables 67 – 108 on Page 113.

MCA/MOCP (cont.)

Table 89 – 50TCQD09

**MCA/MOCP DETERMINATION NO C.O. OR UNPWRD C.O.
2-STAGE COOLING WITH 2-SPEED INDOOR FAN MOTOR**

(Units Produced on or Prior to 02/08/2015)

UNIT	NOM. V-PH-HZ	IFM TYPE	ELEC. HTR			NO C.O. or UNPWR C.O.							
			CRHEATER ****00	Nom (kW)	FLA	NO P.E.				w/ P.E. (pwrd fr/unit)			
						MCA	MAX FUSE or HACR BRKR	DISC. SIZE		MCA	MAX FUSE or HACR BRKR	DISC. SIZE	
								FLA	LRA			FLA	LRA
50TCQD09	208/230-3-60	STD	NONE	–	–	41/41	50/50	43/42	212	45/45	50/50	47/47	216
			117A	7.8/10.4	21.7/25.0	68/72	70/80	68/71	234/237	72/76	80/80	72/75	238/241
			110A	12.0/16.0	33.4/38.5	83/89	90/90	81/87	245/251	87/93	90/100	85/91	249/255
			111A	18.6/24.8	51.7/59.7	106/116	110/125	102/111	264/272	110/119	110/125	106/115	268/276
			112A	24.0/32.0	66.7/77.0	124/137	125/150	119/131	279/289	128/141	150/150	124/135	283/293
			112A+117A	31.8/42.4	88.4/102.0	152/168	175/175	144/160	389/416	155/172	175/175	149/164	393/420
		MED	NONE	–	–	44/43	50/50	46/45	242	48/47	60/60	50/49	246
			117A	7.8/10.4	21.7/25.0	71/74	80/80	71/74	264/267	75/78	80/80	75/78	268/271
			110A	12.0/16.0	33.4/38.5	86/91	90/100	84/89	275/281	89/95	90/100	89/93	279/285
			111A	18.6/24.8	51.7/59.7	109/118	110/125	105/114	294/302	112/122	125/125	110/118	298/306
			112A	24.0/32.0	66.7/77.0	127/139	150/150	122/133	309/319	131/143	150/150	127/138	313/323
			112A+117A	31.8/42.4	88.4/102.0	154/171	175/175	147/162	419/446	158/174	175/175	152/167	423/450
		HIGH	NONE	–	–	44/43	50/50	46/45	242	48/47	60/60	50/49	246
			117A	7.8/10.4	21.7/25.0	71/74	80/80	71/74	264/267	75/78	80/80	75/78	268/271
			110A	12.0/16.0	33.4/38.5	86/91	90/100	84/89	275/281	89/95	90/100	89/93	279/285
	111A		18.6/24.8	51.7/59.7	109/118	110/125	105/114	294/302	112/122	125/125	110/118	298/306	
	112A		24.0/32.0	66.7/77.0	127/139	150/150	122/133	309/319	131/143	150/150	127/138	313/323	
	112A+117A		31.8/42.4	88.4/102.0	154/171	175/175	147/162	419/446	158/174	175/175	152/167	423/450	
	460-3-60	STD	NONE	–	–	19	25	20	111	21	25	22	113
			116A	13.9	16.7	40	40	39	128	42	45	41	130
			113A	16.5	19.8	44	45	42	131	46	50	44	133
			114A	27.8	33.4	61	70	58	144	63	70	60	146
			115A	33.0	39.7	69	70	65	151	70	80	67	153
			114A+116A	41.7	50.2	82	90	77	211	84	90	79	213
MED		NONE	–	–	20	25	21	127	22	25	23	129	
		116A	13.9	16.7	41	45	40	144	43	45	42	146	
		113A	16.5	19.8	45	45	43	147	46	50	45	149	
		114A	27.8	33.4	62	70	59	160	63	70	61	162	
		115A	33.0	39.7	70	70	66	167	71	80	68	169	
		114A+116A	41.7	50.2	83	90	78	227	84	90	80	229	
HIGH		NONE	–	–	20	25	21	127	22	25	23	129	
		116A	13.9	16.7	41	45	40	144	43	45	42	146	
		113A	16.5	19.8	45	45	43	147	46	50	45	149	
		114A	27.8	33.4	62	70	59	160	63	70	61	162	
		115A	33.0	39.7	70	70	66	167	71	80	68	169	
		114A+116A	41.7	50.2	83	90	78	227	84	90	80	229	
575-3-60	STD	NONE	–	–	17	20	17	87	21	25	21	91	
		118A	17.0	20.4	42	45	40	107	46	50	45	111	
		119A	34.0	40.9	68	70	64	128	72	80	68	132	
	MED	NONE	–	–	18	20	19	100	22	25	23	104	
		118A	17.0	20.4	44	45	42	120	48	50	47	124	
		119A	34.0	40.9	70	70	66	141	73	80	70	145	
	HIGH	NONE	–	–	18	20	19	100	22	25	23	104	
		118A	17.0	20.4	44	45	42	120	48	50	47	124	
		119A	34.0	40.9	70	70	66	141	73	80	70	145	

50TCQ

See Legend and Notes for Tables 67 – 108 on Page 113.

MCA/MOCP (cont.)

Table 90 – 50TCQD12

MCA/MOCP DETERMINATION NO C.O. OR UNPWRD C.O. 2-STAGE COOLING WITH SINGLE SPEED INDOOR FAN MOTOR

UNIT	NOM. V – PH – HZ	IFM TYPE	ELEC. HTR			NO C.O. or UNPWR C.O.								
			CRHEATER *****00	Nom (kW)	FLA	NO P.E.				w/ P.E. (pwrdr fr/unit)				
						MCA	MAX FUSE or HACR BRKR	DISC. SIZE		MCA	MAX FUSE or HACR BRKR	DISC. SIZE		
								FLA	LRA			FLA	LRA	
50TCQ	208/230 – 3 – 60	STD	NONE	–	–	49/49	60/60	51/51	309	53/53	60/60	56/55	313	
			117A	7.8/10.4	21.7/25.0	76/80	80/80	76/80	331/334	80/84	80/90	81/84	335/338	
			110A	12.0/16.0	33.4/38.5	91/97	100/100	90/95	342/348	95/101	100/110	94/100	346/352	
			112A	24.0/32.0	66.7/77.0	132/145	150/150	128/140	376/386	136/149	150/150	132/144	380/390	
			112A+117A	31.8/42.4	88.4/102.0	160/176	175/200	153/168	486/513	163/180	175/200	157/173	490/517	
		112A+110A	37.6/50.0	104.2/120.3	179/169	200/175	171/189	517/550	183/173	200/200	175/194	521/554		
		MED	NONE	–	–	53	60	56	338	57	70	60	342	
			117A	7.8/10.4	21.7/25.0	80/84	80/90	81/84	360/363	84/88	90/90	85/89	364/367	
			110A	12.0/16.0	33.4/38.5	94/101	100/110	94/100	371/377	98/105	100/110	98/104	375/381	
			112A	24.0/32.0	66.7/77.0	136/149	150/150	132/144	405/415	140/153	150/175	137/148	409/419	
			112A+117A	31.8/42.4	88.4/102.0	163/180	175/200	157/173	515/542	167/184	175/200	162/177	519/546	
		112A+110A	37.6/50.0	104.2/120.3	183/173	200/200	175/194	546/579	187/177	200/200	180/198	550/583		
		HIGH	NONE	–	–	56/55	60/60	59/58	340	60/59	70/70	63/62	344	
			117A	7.8/10.4	21.7/25.0	83/86	90/90	84/87	362/365	87/90	90/90	88/91	366/369	
			110A	12.0/16.0	33.4/38.5	97/103	100/110	97/102	373/379	101/107	110/110	102/107	377/383	
	112A		24.0/32.0	66.7/77.0	139/151	150/175	136/147	407/417	143/155	150/175	140/151	411/421		
	112A+117A		31.8/42.4	88.4/102.0	166/182	175/200	161/175	517/544	170/186	175/200	165/180	521/548		
	112A+110A	37.6/50.0	104.2/120.3	186/175	200/200	179/196	548/581	190/179	200/200	183/201	552/585			
	50TCQD12	460 – 3 – 60	STD	NONE	–	–	24	30	25	148	26	30	27	150
				116A	13.9	16.7	45	45	44	165	47	50	46	167
				113A	16.5	19.8	49	50	48	168	51	60	50	170
				115A	33.0	39.7	74	80	71	188	76	80	73	190
				114A+116A	41.7	50.2	87	90	83	248	89	90	85	250
			115A+113A	50.0	60.1	84	90	94	268	86	90	96	270	
MED		NONE	–	–	26	30	27	163	28	30	29	165		
		116A	13.9	16.7	47	50	47	180	49	50	49	182		
		113A	16.5	19.8	51	60	50	183	53	60	52	185		
		115A	33.0	39.7	76	80	73	203	78	80	75	205		
		114A+116A	41.7	50.2	89	90	85	263	91	100	87	265		
115A+113A		50.0	60.1	86	90	96	283	88	90	99	285			
HIGH		NONE	–	–	27	30	29	164	29	35	31	166		
		116A	13.9	16.7	48	50	48	181	50	50	50	183		
		113A	16.5	19.8	52	60	51	184	54	60	53	186		
	115A	33.0	39.7	77	80	74	204	79	80	76	206			
	114A+116A	41.7	50.2	90	90	86	264	92	100	88	266			
115A+113A	50.0	60.1	87	90	98	284	89	100	100	286				
575 – 3 – 60	STD	NONE	–	–	18	20	18	105	22	25	23	109		
		118A	17.0	20.4	43	45	42	125	47	50	46	129		
		119A	34.0	40.9	69	70	65	146	73	80	70	150		
		118A+119A	51.0	61.3	79	90	89	228	83	90	93	232		
	MED	NONE	–	–	19	20	19	116	23	25	24	120		
		118A	17.0	20.4	44	45	43	136	48	50	47	140		
		119A	34.0	40.9	70	70	66	157	74	80	71	161		
		118A+119A	51.0	61.3	80	90	90	239	84	90	94	243		
	HIGH	NONE	–	–	22	25	23	130	25	30	27	134		
		118A	17.0	20.4	47	50	46	150	51	60	50	154		
		119A	34.0	40.9	73	80	70	171	76	80	74	175		
		118A+119A	51.0	61.3	83	90	93	253	87	90	97	257		

See Legend and Notes for Tables 67 – 108 on Page 113.

MCA/MOCP (cont.)

Table 91 – 50TCQD12

MCA/MOCP DETERMINATION NO C.O. OR UNPWRD C.O. 2-STAGE COOLING WITH 2-SPEED INDOOR FAN MOTOR

UNIT	NOM. V – PH – HZ	IFM TYPE	ELEC. HTR			NO C.O. or UNPWR C.O.							
			CRHEATER *****00	Nom (kW)	FLA	NO P.E.				w/ P.E. (pwrdr fr/unit)			
						MCA	MAX FUSE or HACR BRKR	DISC. SIZE		MCA	MAX FUSE or HACR BRKR	DISC. SIZE	
								FLA	LRA			FLA	LRA
50TCQD12	208/230 – 3 – 60	STD	NONE	–	–	49/49	60/60	52/51	279	53/53	60/60	56/56	283
			117A	7.8/10.4	21.7/25.0	76/80	80/80	76/80	301/304	80/84	80/90	81/84	305/308
			110A	12.0/16.0	33.4/38.5	91/97	100/100	90/95	312/318	95/101	100/110	94/100	316/322
			112A	24.0/32.0	66.7/77.0	133/145	150/150	128/140	346/356	136/149	150/150	133/144	350/360
			112A+117A	31.8/42.4	88.4/102.0	160/176	175/200	153/168	456/483	164/180	175/200	158/173	460/487
		112A+110A	37.6/50.0	104.2/120.3	179/169	200/175	171/190	487/520	183/173	200/200	176/194	491/524	
		MED	NONE	–	–	53/52	60/60	56/55	329	57/56	70/60	60/59	333
			117A	7.8/10.4	21.7/25.0	80/83	80/90	81/83	351/354	84/87	90/90	85/88	355/358
			110A	12.0/16.0	33.4/38.5	95/100	100/100	94/99	362/368	98/104	100/110	99/103	366/372
			112A	24.0/32.0	66.7/77.0	136/148	150/150	132/143	396/406	140/152	150/175	137/148	400/410
			112A+117A	31.8/42.4	88.4/102.0	163/179	175/200	157/172	506/533	167/183	175/200	162/176	510/537
		112A+110A	37.6/50.0	104.2/120.3	183/172	200/200	176/193	537/570	187/176	200/200	180/197	541/574	
		HIGH	NONE	–	–	56/55	60/60	59/58	340	60/59	70/70	63/62	344
			117A	7.8/10.4	21.7/25.0	83/86	90/90	84/87	362/365	87/90	90/90	88/91	366/369
			110A	12.0/16.0	33.4/38.5	97/103	100/110	97/102	373/379	101/107	110/110	102/107	377/383
	112A		24.0/32.0	66.7/77.0	139/151	150/175	136/147	407/417	143/155	150/175	140/151	411/421	
	112A+117A		31.8/42.4	88.4/102.0	166/182	175/200	161/175	517/544	170/186	175/200	165/180	521/548	
	112A+110A	37.6/50.0	104.2/120.3	186/175	200/200	179/196	548/581	190/179	200/200	183/201	552/585		
	460 – 3 – 60	STD	NONE	–	–	25	30	26	134	26	30	28	136
			116A	13.9	16.7	46	50	45	151	47	50	47	153
			113A	16.5	19.8	49	50	48	154	51	60	50	156
			115A	33.0	39.7	74	80	71	174	76	80	73	176
			114A+116A	41.7	50.2	87	90	83	234	89	90	85	236
		115A+113A	50.0	60.1	85	90	95	254	87	90	97	256	
MED		NONE	–	–	26	30	27	159	28	30	29	161	
		116A	13.9	16.7	47	50	46	176	48	50	48	178	
		113A	16.5	19.8	51	60	50	179	52	60	52	181	
		115A	33.0	39.7	75	80	73	199	77	80	75	201	
		114A+116A	41.7	50.2	89	90	85	259	90	90	87	261	
115A+113A		50.0	60.1	86	90	96	279	88	90	98	281		
HIGH		NONE	–	–	27	30	29	164	29	35	31	166	
		116A	13.9	16.7	48	50	48	181	50	50	50	183	
		113A	16.5	19.8	52	60	51	184	54	60	53	186	
	115A	33.0	39.7	77	80	74	204	79	80	76	206		
	114A+116A	41.7	50.2	90	90	86	264	92	100	88	266		
115A+113A	50.0	60.1	87	90	98	284	89	100	100	286			
575 – 3 – 60	STD	NONE	–	–	19	25	20	107	23	25	24	111	
		118A	17.0	20.4	45	45	44	127	49	50	48	131	
		119A	34.0	40.9	71	80	67	148	74	80	72	152	
		118A+119A	51.0	61.3	81	90	91	230	85	90	95	234	
	MED	NONE	–	–	20	25	21	116	24	30	26	120	
		118A	17.0	20.4	46	50	45	136	50	50	49	140	
		119A	34.0	40.9	72	80	68	157	75	80	73	161	
		118A+119A	51.0	61.3	82	90	92	239	86	90	96	243	
	HIGH	NONE	–	–	22	25	23	130	26	30	28	134	
		118A	17.0	20.4	48	50	47	150	52	60	51	154	
		119A	34.0	40.9	73	80	70	171	77	80	75	175	
		118A+119A	51.0	61.3	84	90	94	253	87	90	98	257	

50TCQ

See Legend and Notes for Tables 67 – 108 on Page 113.

MCA/MOCP (cont.)

Table 92 – 50TCQD14

MCA/MOCP DETERMINATION NO C.O. OR UNPWRD C.O. 2-STAGE COOLING WITH SINGLE SPEED INDOOR FAN MOTOR

UNIT	NOM. V – PH – HZ	IFM TYPE	ELEC. HTR			NO C.O. or UNPWR C.O.							
			CRHEATER *****00	Nom (kW)	FLA	NO P.E.				w/ P.E. (pwrd fr/unit)			
						MCA	MAX FUSE or HACR BRKR	DISC. SIZE		MCA	MAX FUSE or HACR BRKR	DISC. SIZE	
								FLA	LRA			FLA	LRA
50TCQ	208/230 – 3 – 60	STD	NONE	–	–	64/64	80/80	66/66	382	68/67	80/80	71/71	386
			291A	12.4/16.5	34.4/39.7	107/113	110/125	106/112	416/422	111/117	125/125	110/116	420/426
			288A+291A	19.9/26.5	55.3/63.8	133/143	150/150	130/140	493/510	137/147	150/150	134/144	497/514
			294A	25.2/33.5	69.9/80.6	151/164	175/175	147/159	452/463	155/168	175/175	151/163	456/467
			288A+294A	32.7/43.5	90.7/104.7	177/195	200/200	171/187	563/591	181/198	200/200	175/191	567/595
		291A+294A	37.6/50.0	104.3/120.3	194/184	200/200	186/205	591/623	198/188	200/200	191/209	595/627	
		MED	NONE	–	–	64/64	80/80	66/66	382	68/67	80/80	71/71	386
			291A	12.4/16.5	34.4/39.7	107/113	110/125	106/112	416/422	111/117	125/125	110/116	420/426
			288A+291A	19.9/26.5	55.3/63.8	133/143	150/150	130/140	493/510	137/147	150/150	134/144	497/514
			294A	25.2/33.5	69.9/80.6	151/164	175/175	147/159	452/463	155/168	175/175	151/163	456/467
			288A+294A	32.7/43.5	90.7/104.7	177/195	200/200	171/187	563/591	181/198	200/200	175/191	567/595
		291A+294A	37.6/50.0	104.3/120.3	194/184	200/200	186/205	591/623	198/188	200/200	191/209	595/627	
		HIGH	NONE	–	–	76	90	80	402	80	100	85	406
			291A	12.4/16.5	34.4/39.7	119/125	125/125	120/126	436/442	123/129	125/150	124/130	440/446
			288A+291A	19.9/26.5	55.3/63.8	145/156	150/175	144/154	513/530	149/159	150/175	148/158	517/534
294A	25.2/33.5		69.9/80.6	163/177	175/200	161/173	472/483	167/180	175/200	165/177	476/487		
288A+294A	32.7/43.5		90.7/104.7	189/207	200/225	184/201	583/611	193/210	200/225	189/205	587/615		
291A+294A	37.6/50.0	104.3/120.3	206/196	225/225	200/219	611/643	210/200	225/225	204/223	615/647			
50TCQD14	460 – 3 – 60	STD	NONE	–	–	31	40	32	192	33	40	34	194
			292A	16.5	19.9	56	60	55	212	58	60	57	214
			289A+292A	26.5	31.9	71	80	69	256	73	80	71	258
			295A	33.5	40.3	81	90	78	232	83	90	80	234
			289A+295A	43.5	52.3	96	100	92	297	98	100	94	299
		292A+295A	50.0	60.2	91	100	101	312	93	100	103	314	
		MED	NONE	–	–	31	40	32	192	33	40	34	194
			292A	16.5	19.9	56	60	55	212	58	60	57	214
			289A+292A	26.5	31.9	71	80	69	256	73	80	71	258
			295A	33.5	40.3	81	90	78	232	83	90	80	234
			289A+295A	43.5	52.3	96	100	92	297	98	100	94	299
		292A+295A	50.0	60.2	91	100	101	312	93	100	103	314	
		HIGH	NONE	–	–	37	45	39	202	39	45	41	204
			292A	16.5	19.9	62	70	62	222	64	70	64	224
			289A+292A	26.5	31.9	77	80	76	266	79	80	78	268
295A	33.5		40.3	87	90	85	242	89	90	87	244		
289A+295A	43.5		52.3	102	110	99	307	104	110	101	309		
292A+295A	50.0	60.2	97	100	108	322	99	110	110	324			
50TCQD14	575 – 3 – 60	STD	NONE	–	–	24	30	25	136	28	30	30	140
			293A	16.5	15.9	44	45	43	152	48	50	48	156
			290A+293A	26.5	25.5	56	60	55	187	60	60	59	191
			296A	33.5	32.2	65	70	62	168	69	70	67	172
			290A+296A	43.5	41.8	77	80	73	220	81	90	78	224
		293A+296A	50.0	48.1	73	80	81	232	76	80	85	236	
		MED	NONE	–	–	24	30	25	136	28	30	30	140
			293A	16.5	15.9	44	45	43	152	48	50	48	156
			290A+293A	26.5	25.5	56	60	55	187	60	60	59	191
			296A	33.5	32.2	65	70	62	168	69	70	67	172
			290A+296A	43.5	41.8	77	80	73	220	81	90	78	224
		293A+296A	50.0	48.1	73	80	81	232	76	80	85	236	
		HIGH	NONE	–	–	31	35	32	148	35	40	37	152
			293A	16.5	15.9	51	60	51	164	54	60	55	168
			290A+293A	26.5	25.5	63	70	62	199	66	70	66	203
296A	33.5		32.2	71	80	69	180	75	80	74	184		
290A+296A	43.5		41.8	83	90	80	232	87	90	85	236		
293A+296A	50.0	48.1	79	90	88	244	83	90	92	248			

See Legend and Notes for Tables 67 – 108 on Page 113.

MCA/MOCP (cont.)

Table 93 – 50TCQD14

MCA/MOCP DETERMINATION NO C.O. OR UNPWRD C.O. 2-STAGE COOLING WITH 2-SPEED INDOOR FAN MOTOR

UNIT	NOM. V – PH – HZ	IFM TYPE	ELEC. HTR			NO C.O. or UNPWR C.O.							
			CRHEATER *****00	Nom (kW)	FLA	NO P.E.				w/ P.E. (pwrdr fr/unit)			
						MCA	MAX FUSE or HACR BRKR	DISC. SIZE		MCA	MAX FUSE or HACR BRKR	DISC. SIZE	
								FLA	LRA			FLA	LRA
50TCQD14	208/230 – 3 – 60	STD	NONE	–	–	64/63	80/80	67/66	363	68/67	80/80	71/70	367
			291A	12.4/16.5	34.4/39.7	107/113	110/125	106/111	397/403	111/117	125/125	111/116	401/407
			288A+291A	19.9/26.5	55.3/63.8	133/143	150/150	130/139	474/491	137/147	150/150	135/143	478/495
			294A	25.2/33.5	69.9/80.6	151/164	175/175	147/158	433/444	155/168	175/175	151/163	437/448
			288A+294A	32.7/43.5	90.7/104.7	177/194	200/200	171/186	544/572	181/198	200/200	175/190	548/576
		291A+294A	37.6/50.0	104.3/120.3	194/183	200/200	187/204	572/604	198/187	200/200	191/208	576/608	
		MED	NONE	–	–	64/63	80/80	67/66	363	68/67	80/80	71/70	367
			291A	12.4/16.5	34.4/39.7	107/113	110/125	106/111	397/403	111/117	125/125	111/116	401/407
			288A+291A	19.9/26.5	55.3/63.8	133/143	150/150	130/139	474/491	137/147	150/150	135/143	478/495
			294A	25.2/33.5	69.9/80.6	151/164	175/175	147/158	433/444	155/168	175/175	151/163	437/448
			288A+294A	32.7/43.5	90.7/104.7	177/194	200/200	171/186	544/572	181/198	200/200	175/190	548/576
		291A+294A	37.6/50.0	104.3/120.3	194/183	200/200	187/204	572/604	198/187	200/200	191/208	576/608	
		HIGH	NONE	–	–	76	90	80	402	80	100	85	406
			291A	12.4/16.5	34.4/39.7	119/125	125/125	120/126	436/442	123/129	125/150	124/130	440/446
			288A+291A	19.9/26.5	55.3/63.8	145/156	150/175	144/154	513/530	149/159	150/175	148/158	517/534
294A	25.2/33.5		69.9/80.6	163/177	175/200	161/173	472/483	167/180	175/200	165/177	476/487		
288A+294A	32.7/43.5		90.7/104.7	189/207	200/225	184/201	583/611	193/210	200/225	189/205	587/615		
291A+294A	37.6/50.0	104.3/120.3	206/196	225/225	200/219	611/643	210/200	225/225	204/223	615/647			
50TCQD14	460 – 3 – 60	STD	NONE	–	–	31	40	32	183	32	40	34	185
			292A	16.5	19.9	55	60	54	203	57	60	56	205
			289A+292A	26.5	31.9	70	70	68	247	72	80	70	249
			295A	33.5	40.3	81	90	78	223	83	90	80	225
			289A+295A	43.5	52.3	96	100	92	288	98	100	94	290
		292A+295A	50.0	60.2	91	100	101	303	93	100	103	305	
		MED	NONE	–	–	31	40	32	183	32	40	34	185
			292A	16.5	19.9	55	60	54	203	57	60	56	205
			289A+292A	26.5	31.9	70	70	68	247	72	80	70	249
			295A	33.5	40.3	81	90	78	223	83	90	80	225
			289A+295A	43.5	52.3	96	100	92	288	98	100	94	290
		292A+295A	50.0	60.2	91	100	101	303	93	100	103	305	
		HIGH	NONE	–	–	37	45	39	202	39	45	41	204
			292A	16.5	19.9	62	70	62	222	64	70	64	224
			289A+292A	26.5	31.9	77	80	76	266	79	80	78	268
295A	33.5		40.3	87	90	85	242	89	90	87	244		
289A+295A	43.5		52.3	102	110	99	307	104	110	101	309		
292A+295A	50.0	60.2	97	100	108	322	99	110	110	324			
50TCQD14	575 – 3 – 60	STD	NONE	–	–	26	30	27	136	30	35	32	140
			293A	16.5	15.9	46	50	45	152	50	50	50	156
			290A+293A	26.5	25.5	58	60	56	187	62	70	61	191
			296A	33.5	32.2	66	70	64	168	70	70	69	172
			290A+296A	43.5	41.8	78	80	75	220	82	90	80	224
		293A+296A	50.0	48.1	74	80	82	232	78	80	87	236	
		MED	NONE	–	–	26	30	27	136	30	35	32	140
			293A	16.5	15.9	46	50	45	152	50	50	50	156
			290A+293A	26.5	25.5	58	60	56	187	62	70	61	191
			296A	33.5	32.2	66	70	64	168	70	70	69	172
			290A+296A	43.5	41.8	78	80	75	220	82	90	80	224
		293A+296A	50.0	48.1	74	80	82	232	78	80	87	236	
		HIGH	NONE	–	–	31	35	32	148	35	40	37	152
			293A	16.5	15.9	51	60	51	164	54	60	55	168
			290A+293A	26.5	25.5	63	70	62	199	66	70	66	203
296A	33.5		32.2	71	80	69	180	75	80	74	184		
290A+296A	43.5		41.8	83	90	80	232	87	90	85	236		
293A+296A	50.0	48.1	79	90	88	244	83	90	92	248			

50TCQ

See Legend and Notes for Tables 67 – 108 on Page 113.

MCA/MOCP (cont.)

Table 94 – 50TCQA04

MCA/MOCP DETERMINATION WITH PWRD C.O. SINGLE STAGE COOLING WITH SINGLE SPEED INDOOR FAN MOTOR

UNIT	NOM. V – PH – HZ	IFMTYPE	ELEC. HTR			w/ PWRD C.O.							
			CRHEATER ****00	Nom (kW)	FLA	NO P.E.				w/ P.E. (pwrd fr/unit)			
						MCA	MAX FUSE or HACR BRKR	DISC. SIZE		MCA	MAX FUSE or HACR BRKR	DISC. SIZE	
								FLA	LRA			FLA	LRA
50TCQA04	208/230 – 1 – 60	DD – STD	NONE	–	–	36	50	36	126	–	–	–	–
			101A	3.3/4.4	15.9/18.3	56/59	60/60	54/57	142/144	–	–	–	–
			102A	4.9/6.5	23.5/27.1	65/70	70/80	63/67	150/153	–	–	–	–
			103B	6.5/8.7	31.4/36.3	75/81	80/90	72/77	157/162	–	–	–	–
			104B	7.9/10.5	37.9/43.8	83/91	90/100	79/86	164/170	–	–	–	–
	102A+102A	9.8/13.0	46.9/54.2	95/104	100/110	90/98	220/234	–	–	–	–		
	208/230 – 3 – 60	DD – STD	NONE	–	–	30	40	30	102	32	40	32	104
			101A	3.3/4.4	9.2/10.6	42/43	50/50	41/42	111/113	43/45	50/50	43/45	113/115
			102A	4.9/6.5	13.6/15.6	47/50	50/50	46/48	116/118	49/51	50/60	48/50	118/120
			103B	6.5/8.7	18.1/20.9	53/56	60/60	51/54	120/123	55/58	60/60	53/56	122/125
			104B	7.9/10.5	21.9/25.3	57/62	60/70	55/59	124/127	59/64	60/70	58/62	126/129
		105A	12.0/16.0	33.4/38.5	72/78	80/80	69/75	135/141	74/80	80/80	71/77	137/143	
		MED	NONE	–	–	28/28	40/40	28/27	131	30/29	40/40	30/30	133
			101A	3.3/4.4	9.2/10.6	39/41	45/50	38/40	140/142	41/43	50/50	40/42	142/144
			102A	4.9/6.5	13.6/15.6	45/47	50/50	43/45	145/147	47/49	50/50	46/47	147/149
			103B	6.5/8.7	18.1/20.9	50/54	60/60	49/51	149/152	52/56	60/60	51/54	151/154
			104B	7.9/10.5	21.9/25.3	55/59	60/60	53/56	153/156	57/61	60/70	55/59	155/158
		105A	12.0/16.0	33.4/38.5	70/76	70/80	66/72	164/170	72/78	80/80	68/74	166/172	
		HIGH	NONE	–	–	30/29	40/40	30/29	152	31/31	40/40	32/32	154
			101A	3.3/4.4	9.2/10.6	41/43	50/50	40/42	161/163	43/45	50/50	42/44	163/165
102A			4.9/6.5	13.6/15.6	47/49	50/50	45/47	166/168	48/51	50/60	47/50	168/170	
103B	6.5/8.7		18.1/20.9	52/55	60/60	50/53	170/173	54/57	60/60	53/56	172/175		
104B	7.9/10.5		21.9/25.3	57/61	60/70	55/59	174/177	59/63	60/70	57/61	176/179		
105A	12.0/16.0	33.4/38.5	71/77	80/80	68/74	185/191	73/79	80/80	70/76	187/193			
460 – 3 – 60	DD – STD	NONE	–	–	15	20	15	51	16	20	16	52	
		106A	6.0	7.2	24	25	23	58	25	25	24	59	
		107A	8.8	10.6	28	30	27	62	29	30	28	63	
		108A	11.5	13.8	32	35	30	65	33	35	32	66	
		109A	14.0	16.8	36	40	34	68	37	40	35	69	
	MED	NONE	–	–	13	15	13	65	14	20	14	66	
		106A	6.0	7.2	22	25	21	72	23	25	22	73	
		107A	8.8	10.6	26	30	25	76	27	30	26	77	
		108A	11.5	13.8	30	30	29	79	31	35	30	80	
		109A	14.0	16.8	34	35	32	82	35	35	33	83	
	HIGH	NONE	–	–	14	20	14	75	15	20	15	76	
		106A	6.0	7.2	23	25	22	82	24	25	23	83	
		107A	8.8	10.6	27	30	26	86	28	30	27	87	
		108A	11.5	13.8	31	35	30	89	32	35	31	90	
		109A	14.0	16.8	35	35	33	92	36	40	34	93	
575 – 3 – 60	DD – STD	NONE	–	–	12	15	12	37	14	15	14	39	
	MED	NONE	–	–	9	15	9	40	11	15	11	42	
	HIGH	NONE	–	–	10	15	10	44	12	15	12	46	

See Legend and Notes for Tables 67 – 108 on Page 113.

MCA/MOCP (cont.)

Table 95 – 50TCQA05

MCA/MOCP DETERMINATION WITH PWRD C.O. SINGLE STAGE COOLING WITH SINGLE SPEED INDOOR FAN MOTOR

UNIT	NOM. V – PH – HZ	IFMTYPE	ELEC. HTR			w/ PWRD C.O.							
			CRHEATER ****00	Nom (kW)	FLA	NO P.E.				w/ P.E. (pwrd fr/unit)			
						MCA	MAX FUSE or HACR BRKR	DISC. SIZE		MCA	MAX FUSE or HACR BRKR	DISC. SIZE	
								FLA	LRA			FLA	LRA
50TCQA05	208/230-1-60	DD-STD	NONE	-	-	41	60	41	133	-	-	-	-
			101A	3.3/4.4	15.9/18.3	61/64	70/80	59/62	149/151	-	-	-	-
			103B	6.5/8.7	31.4/36.3	81/87	90/90	77/83	164/169	-	-	-	-
			102A+102A	9.8/13.0	46.9/54.2	100/109	100/110	95/103	227/241	-	-	-	-
			103B+103B	13.1/17.4	62.8/72.5	120/132	125/150	113/124	259/278	-	-	-	-
	104B+104B	15.8/21.0	75.8/87.5	136/151	150/175	128/141	285/308	-	-	-	-		
	208/230-3-60	DD-STD	NONE	-	-	31	40	32	99	33	45	34	101
			102A	4.9/6.5	13.6/15.6	48/51	50/60	47/49	113/115	50/53	60/60	49/52	115/117
			103B	6.5/8.7	18.1/20.9	54/57	60/60	52/56	117/120	56/59	60/60	55/58	119/122
			105A	12.0/16.0	33.4/38.5	73/79	80/80	70/76	132/138	75/81	80/90	72/78	134/140
			104B+104B	15.8/21.0	43.8/50.5	86/94	90/100	82/90	187/200	88/96	90/100	84/92	189/202
		MED	NONE	-	-	29/29	40/40	29/29	128	31/31	40/40	31/31	130
			102A	4.9/6.5	13.6/15.6	46/48	50/50	45/47	142/144	48/50	50/50	47/49	144/146
			103B	6.5/8.7	18.1/20.9	52/55	60/60	50/53	146/149	54/57	60/60	52/55	148/151
			105A	12.0/16.0	33.4/38.5	71/77	80/80	67/73	161/167	73/79	80/80	70/75	163/169
			104B+104B	15.8/21.0	43.8/50.5	84/92	90/100	79/87	216/229	86/94	90/100	82/89	218/231
		HIGH	NONE	-	-	31/31	40/40	31/31	149	33/32	45/45	33/33	151
			102A	4.9/6.5	13.6/15.6	48/50	50/50	47/49	163/165	50/52	50/60	49/51	165/167
			103B	6.5/8.7	18.1/20.9	53/57	60/60	52/55	167/170	55/59	60/60	54/57	169/172
			105A	12.0/16.0	33.4/38.5	73/79	80/80	69/75	182/188	74/81	80/90	72/77	184/190
			104B+104B	15.8/21.0	43.8/50.5	86/94	90/100	81/89	237/250	87/96	90/100	83/91	239/252
	460-3-60	DD-STD	NONE	-	-	15	20	15	49	16	20	16	50
			106A	6.0	7.2	24	25	23	56	25	25	25	57
			108A	11.5	13.8	32	35	31	63	33	35	32	64
109A			14.0	16.8	36	40	35	66	37	40	36	67	
108A+108A			23.0	27.7	50	50	47	104	51	60	48	105	
MED		NONE	-	-	14	15	13	63	15	20	15	64	
		106A	6.0	7.2	23	25	22	70	24	25	23	71	
		108A	11.5	13.8	31	35	29	77	32	35	30	78	
		109A	14.0	16.8	35	35	33	80	36	40	34	81	
108A+108A		23.0	27.7	48	50	45	118	49	50	46	119		
HIGH		NONE	-	-	15	20	14	73	16	20	16	74	
		106A	6.0	7.2	24	25	23	80	25	25	24	81	
	108A	11.5	13.8	32	35	30	87	33	35	32	88		
	109A	14.0	16.8	36	40	34	90	37	40	35	91		
	108A+108A	23.0	27.7	49	50	46	128	50	50	47	129		
575-3-60	DD-STD	NONE	-	-	13	15	13	41	15	20	15	43	
	MED	NONE	-	-	10	15	10	44	12	15	12	46	
	HIGH	NONE	-	-	11	15	10	48	13	15	13	50	

50TCQ

See Legend and Notes for Tables 67 – 108 on Page 113.

MCA/MOCP (cont.)

Table 96 – 50TCQA06

MCA/MOCP DETERMINATION WITH PWRD C.O. SINGLE STAGE COOLING WITH SINGLE SPEED INDOOR FAN MOTOR

UNIT	NOM. V – PH – HZ	IFMTYPE	ELEC. HTR			w/ PWRD C.O.							
			CRHEATER ****00	Nom (kW)	FLA	NO P.E.				w/ P.E. (pwrd fr/unit)			
						MCA	MAX FUSE or HACR BRKR	DISC. SIZE		MCA	MAX FUSE or HACR BRKR	DISC. SIZE	
								FLA	LRA			FLA	LRA
50TCQA06	208/230 – 1 – 60	DD – STD	NONE	–	–	47	60	46	150	–	–	–	–
			102A	4.9/6.5	23.5/27.1	76/81	80/90	73/77	174/177	–	–	–	–
			103B	6.5/8.7	31.4/36.3	86/92	100/100	82/88	181/186	–	–	–	–
			102A+102A	9.8/13.0	46.9/54.2	106/115	110/125	100/108	244/258	–	–	–	–
			103B+103B	13.1/17.4	62.8/72.5	125/138	125/150	118/129	276/295	–	–	–	–
	104B+104B	15.8/21.0	75.8/87.5	142/156	150/175	133/147	302/325	–	–	–	–		
	208/230 – 3 – 60	DD – STD	NONE	–	–	34	45	34	126	36	50	36	128
			102A	4.9/6.5	13.6/15.6	51/53	60/60	49/52	140/142	53/55	60/60	52/54	142/144
			104B	7.9/10.5	21.9/25.3	61/65	70/70	59/63	148/151	63/67	70/70	61/65	150/153
			105A	12.0/16.0	33.4/38.5	75/82	80/90	72/78	159/165	77/84	80/90	74/80	161/167
			104B+104B	15.8/21.0	43.8/50.5	88/97	90/100	84/92	214/227	90/99	90/100	86/94	216/229
		104B+105A	19.9/26.5	55.2/63.8	103/113	110/125	97/107	236/254	105/115	110/125	99/109	238/256	
		MED	NONE	–	–	33/33	45/45	33/33	176	35/35	50/50	35/35	178
			102A	4.9/6.5	13.6/15.6	50/52	60/60	49/51	190/192	52/54	60/60	51/53	192/194
			104B	7.9/10.5	21.9/25.3	61/65	70/70	58/62	198/201	62/66	70/70	60/64	200/203
			105A	12.0/16.0	33.4/38.5	75/81	80/90	72/77	209/215	77/83	80/90	74/79	211/217
			104B+104B	15.8/21.0	43.8/50.5	88/96	90/100	83/91	264/277	90/98	90/100	86/93	266/279
		104B+105A	19.9/26.5	55.2/63.8	102/113	110/125	97/106	286/304	104/115	110/125	99/108	288/306	
		HIGH	NONE	–	–	35/35	45/45	35/35	191	37/36	50/50	37/37	193
			102A	4.9/6.5	13.6/15.6	52/54	60/60	50/53	205/207	54/56	60/60	53/55	207/209
104B			7.9/10.5	21.9/25.3	62/66	70/70	60/64	213/216	64/68	70/70	62/66	215/218	
105A	12.0/16.0		33.4/38.5	76/83	80/90	73/79	224/230	78/85	80/90	75/81	226/232		
104B+104B	15.8/21.0		43.8/50.5	89/98	90/100	85/93	279/292	91/100	100/100	87/95	281/294		
104B+105A	19.9/26.5	55.2/63.8	104/114	110/125	98/108	301/319	106/116	110/125	101/110	303/321			
460 – 3 – 60	DD – STD	NONE	–	–	17	20	17	60	18	25	18	61	
		106A	6.0	7.2	26	30	25	67	27	30	26	68	
		108A	11.5	13.8	34	35	33	74	35	35	34	75	
		109A	14.0	16.8	38	40	36	77	39	40	37	78	
		108A+108A	23.0	27.7	52	60	49	115	53	60	50	116	
	108A+109A	25.5	30.7	55	60	52	121	56	60	53	122		
	MED	NONE	–	–	16	20	16	84	17	20	17	85	
		106A	6.0	7.2	25	30	24	91	26	30	26	92	
		108A	11.5	13.8	34	35	32	98	35	35	33	99	
		109A	14.0	16.8	37	40	36	101	38	40	37	102	
		108A+108A	23.0	27.7	51	60	48	139	52	60	49	140	
	108A+109A	25.5	30.7	55	60	52	145	56	60	53	146		
	HIGH	NONE	–	–	17	20	17	92	18	25	18	93	
		106A	6.0	7.2	26	30	25	99	27	30	27	100	
		108A	11.5	13.8	35	35	33	106	36	40	34	107	
109A		14.0	16.8	38	40	36	109	39	40	38	110		
108A+108A		23.0	27.7	52	60	49	147	53	60	50	148		
108A+109A	25.5	30.7	56	60	52	153	57	60	54	154			
575 – 3 – 60	DD – STD	NONE	–	–	14	15	14	47	16	20	16	49	
	MED	NONE	–	–	12	15	12	54	14	15	14	56	
	HIGH	NONE	–	–	13	15	13	65	15	20	15	67	

See Legend and Notes for Tables 67 – 108 on Page 113.

MCA/MOCP (cont.)

Table 97 – 50TCQA07

MCA/MOCP DETERMINATION WITH PWRD C.O. SINGLE STAGE COOLING WITH SINGLE SPEED INDOOR FAN MOTOR

(Units Produced On or After 02/09/2015)

UNIT	NOM. V-PH-HZ	IFMTYPE	ELEC. HTR			w/ PWRD C.O.							
			CRHEATER ****00	Nom (kW)	FLA	NO P.E.				w/ P.E. (pwrd fr/unit)			
						MCA	MAX FUSE or HACR BRKR	DISC. SIZE		MCA	MAX FUSE or HACR BRKR	DISC. SIZE	
								FLA	LRA			FLA	LRA
50TCQA07	208/230-3-60	STD	NONE	–	–	36/35	50/50	35/35	168	38/37	50/50	37/37	170
			102A	4.9/6.5	13.6/15.6	53/55	60/60	51/53	182/184	55/57	60/60	53/55	184/186
			104B	7.9/10.5	21.9/25.3	63/67	70/70	60/64	190/193	65/69	70/80	62/66	192/195
			105A	12.0/16.0	33.4/38.5	77/84	80/90	73/79	201/207	79/85	80/90	76/81	203/209
			104B+104B	15.8/21.0	43.8/50.5	90/99	90/100	85/93	256/269	92/100	100/100	88/95	258/271
			104B+105A	19.9/26.5	55.2/63.8	105/115	110/125	99/108	278/296	107/117	110/125	101/110	280/298
		MED	NONE	–	–	39/39	50/50	39/39	204	41/41	50/50	41/41	206
			102A	4.9/6.5	13.6/15.6	56/58	60/60	54/57	218/220	58/60	60/70	57/59	220/222
			104B	7.9/10.5	21.9/25.3	66/70	70/80	64/68	226/229	68/72	80/80	66/70	228/231
			105A	12.0/16.0	33.4/38.5	81/87	90/90	77/83	237/243	83/89	90/90	79/85	239/245
			104B+104B	15.8/21.0	43.8/50.5	94/102	100/110	89/97	292/305	96/104	100/110	91/99	294/307
			104B+105A	19.9/26.5	55.2/63.8	108/119	110/125	102/112	314/332	110/120	110/125	104/114	316/334
		HIGH	NONE	–	–	39/39	50/50	39/39	204	41/41	50/50	41/41	206
			102A	4.9/6.5	13.6/15.6	56/58	60/60	54/57	218/220	58/60	60/70	57/59	220/222
			104B	7.9/10.5	21.9/25.3	66/70	70/80	64/68	226/229	68/72	80/80	66/70	228/231
			105A	12.0/16.0	33.4/38.5	81/87	90/90	77/83	237/243	83/89	90/90	79/85	239/245
			104B+104B	15.8/21.0	43.8/50.5	94/102	100/110	89/97	292/305	96/104	100/110	91/99	294/307
			104B+105A	19.9/26.5	55.2/63.8	108/119	110/125	102/112	314/332	110/120	110/125	104/114	316/334
50TCQA07	460-3-60	STD	NONE	–	–	18	25	17	84	19	25	19	85
			106A	6.0	7.2	27	30	26	91	28	30	27	92
			108A	11.5	13.8	35	40	33	98	36	40	35	99
			109A	14.0	16.8	39	40	37	101	40	45	38	102
			108A+108A	23.0	27.7	53	60	49	139	54	60	50	140
			108A+109A	25.5	30.7	56	60	53	145	57	60	54	146
		MED	NONE	–	–	20	25	19	102	21	30	21	103
			106A	6.0	7.2	29	30	28	109	30	30	29	110
			108A	11.5	13.8	37	40	35	116	38	40	36	117
			109A	14.0	16.8	41	45	39	119	42	45	40	120
			108A+108A	23.0	27.7	54	60	51	157	55	60	52	158
			108A+109A	25.5	30.7	58	60	55	163	59	60	56	164
		HIGH	NONE	–	–	20	25	19	102	21	30	21	103
			106A	6.0	7.2	29	30	28	109	30	30	29	110
			108A	11.5	13.8	37	40	35	116	38	40	36	117
			109A	14.0	16.8	41	45	39	119	42	45	40	120
			108A+108A	23.0	27.7	54	60	51	157	55	60	52	158
			108A+109A	25.5	30.7	58	60	55	163	59	60	56	164
575-3-60	STD	NONE	–	–	14	20	13	61	16	20	15	63	
	MED	NONE	–	–	15	20	14	76	17	20	17	78	
	HIGH	NONE	–	–	15	20	14	76	17	20	17	78	

50TCQ

See Legend and Notes for Tables 67–108 on Page 113.

MCA/MOCP (cont.)

Table 98 – 50TCQA07

MCA/MOCP DETERMINATION WITH PWRD C.O. SINGLE STAGE COOLING WITH SINGLE SPEED INDOOR FAN MOTOR

(Units Produced on or Prior to 02/08/2015)

UNIT	NOM. V-PH-HZ	IFMTYPE	ELEC. HTR			w/ PWRD C.O.							
			CRHEATER ****00	Nom (kW)	FLA	NO P.E.				w/ P.E. (pwrd fr/unit)			
						MCA	MAX FUSE or HACR BRKR	DISC. SIZE		MCA	MAX FUSE or HACR BRKR	DISC. SIZE	
								FLA	LRA			FLA	LRA
50TCQA07	208/230-3-60	STD	NONE	-	-	36/35	50/50	35/35	168	38/37	50/50	37/37	170
			102A	4.9/6.5	13.6/15.6	53/55	60/60	51/53	182/184	55/57	60/60	53/55	184/186
			104B	7.9/10.5	21.9/25.3	63/67	70/70	60/64	190/193	65/69	70/80	62/66	192/195
			105A	12.0/16.0	33.4/38.5	77/84	80/90	73/79	201/207	79/85	80/90	76/81	203/209
			104B+104B	15.8/21.0	43.8/50.5	90/99	90/100	85/93	256/269	92/100	100/100	88/95	258/271
			104B+105A	19.9/26.5	55.2/63.8	105/115	110/125	99/108	278/296	107/117	110/125	101/110	280/298
		MED	NONE	-	-	39/39	50/50	39/39	204	41/41	50/50	41/41	206
			102A	4.9/6.5	13.6/15.6	56/58	60/60	54/57	218/220	58/60	60/70	57/59	220/222
			104B	7.9/10.5	21.9/25.3	66/70	70/80	64/68	226/229	68/72	80/80	66/70	228/231
			105A	12.0/16.0	33.4/38.5	81/87	90/90	77/83	237/243	83/89	90/90	79/85	239/245
			104B+104B	15.8/21.0	43.8/50.5	94/102	100/110	89/97	292/305	96/104	100/110	91/99	294/307
			104B+105A	19.9/26.5	55.2/63.8	108/119	110/125	102/112	314/332	110/120	110/125	104/114	316/334
		HIGH	NONE	-	-	39/39	50/50	39/39	204	41/41	50/50	41/41	206
			102A	4.9/6.5	13.6/15.6	56/58	60/60	54/57	218/220	58/60	60/70	57/59	220/222
			104B	7.9/10.5	21.9/25.3	66/70	70/80	64/68	226/229	68/72	80/80	66/70	228/231
			105A	12.0/16.0	33.4/38.5	81/87	90/90	77/83	237/243	83/89	90/90	79/85	239/245
			104B+104B	15.8/21.0	43.8/50.5	94/102	100/110	89/97	292/305	96/104	100/110	91/99	294/307
			104B+105A	19.9/26.5	55.2/63.8	108/119	110/125	102/112	314/332	110/120	110/125	104/114	316/334
50TCQA07	460-3-60	STD	NONE	-	-	18	25	17	84	19	25	19	85
			106A	6.0	7.2	27	30	26	91	28	30	27	92
			108A	11.5	13.8	35	40	33	98	36	40	35	99
			109A	14.0	16.8	39	40	37	101	40	45	38	102
			108A+108A	23.0	27.7	53	60	49	139	54	60	50	140
			108A+109A	25.5	30.7	56	60	53	145	57	60	54	146
		MED	NONE	-	-	20	25	19	102	21	30	21	103
			106A	6.0	7.2	29	30	28	109	30	30	29	110
			108A	11.5	13.8	37	40	35	116	38	40	36	117
			109A	14.0	16.8	41	45	39	119	42	45	40	120
			108A+108A	23.0	27.7	54	60	51	157	55	60	52	158
			108A+109A	25.5	30.7	58	60	55	163	59	60	56	164
		HIGH	NONE	-	-	20	25	19	102	21	30	21	103
			106A	6.0	7.2	29	30	28	109	30	30	29	110
			108A	11.5	13.8	37	40	35	116	38	40	36	117
			109A	14.0	16.8	41	45	39	119	42	45	40	120
			108A+108A	23.0	27.7	54	60	51	157	55	60	52	158
			108A+109A	25.5	30.7	58	60	55	163	59	60	56	164
575-3-60	STD	NONE	-	-	14	20	13	61	16	20	15	63	
	MED	NONE	-	-	15	20	14	76	17	20	17	78	
	HIGH	NONE	-	-	15	20	14	76	17	20	17	78	

See Legend and Notes for Tables 67-108 on Page 113.

MCA/MOCP (cont.)

Table 99 – 50TCQD08

MCA/MOCP DETERMINATION WITH PWRD C.O. 2-STAGE COOLING WITH SINGLE SPEED INDOOR FAN MOTOR

UNIT	NOM. V – PH – HZ	IFM TYPE	ELEC. HTR			w/ PWRD C.O.							
			CRHEATER ****00	Nom (kW)	FLA	NO P.E.				w/ P.E. (pwrd fr/unit)			
						MCA	MAX FUSE or HACR BRKR	DISC. SIZE		MCA	MAX FUSE or HACR BRKR	DISC. SIZE	
								FLA	LRA			FLA	LRA
50TCQD08	208/230 – 3 – 60	STD	NONE	–	–	43/43	50/50	45/45	215	47/46	50/50	49/49	219
			117A	7.8/10.4	21.7/25.0	70/74	70/80	70/73	237/240	74/78	80/80	74/78	241/244
			110A	12.0/16.0	33.4/38.5	85/91	90/100	83/89	248/254	88/95	90/100	88/93	252/258
			111A	18.6/24.8	51.7/59.7	108/117	110/125	105/113	267/275	111/121	125/125	109/118	271/279
			112A	24.0/32.0	66.7/77.0	126/139	150/150	122/133	282/292	130/143	150/150	126/138	286/296
		112A+117A	31.8/42.4	88.4/102.0	153/170	175/175	147/162	392/419	157/174	175/175	151/166	396/423	
		MED	NONE	–	–	46/46	50/50	49/49	251	50/50	60/60	53/53	255
			117A	7.8/10.4	21.7/25.0	73/77	80/80	74/77	273/276	77/81	80/90	78/82	277/280
			110A	12.0/16.0	33.4/38.5	88/94	90/100	87/93	284/290	92/98	100/100	92/97	288/294
	111A		18.6/24.8	51.7/59.7	111/121	125/125	108/117	303/311	115/124	125/125	113/122	307/315	
	HIGH	112A	24.0/32.0	66.7/77.0	130/142	150/150	125/137	318/328	133/146	150/150	130/142	322/332	
		112A+117A	31.8/42.4	88.4/102.0	157/174	175/175	150/166	428/455	160/177	175/200	155/170	432/459	
		NONE	–	–	46/46	50/50	49/49	251	50/50	60/60	53/53	255	
		117A	7.8/10.4	21.7/25.0	73/77	80/80	74/77	273/276	77/81	80/90	78/82	277/280	
		110A	12.0/16.0	33.4/38.5	88/94	90/100	87/93	284/290	92/98	100/100	92/97	288/294	
460 – 3 – 60	STD	NONE	–	–	20	25	21	106	22	25	23	108	
		116A	13.9	16.7	41	45	40	123	43	45	43	125	
		113A	16.5	19.8	45	45	44	126	47	50	46	128	
		114A	27.8	33.4	62	70	60	139	64	70	62	141	
		115A	33.0	39.7	70	70	67	146	72	80	69	148	
	114A+116A	41.7	50.2	83	90	79	206	85	90	81	208		
	MED	NONE	–	–	22	25	23	124	24	30	25	126	
		116A	13.9	16.7	43	45	42	141	45	45	45	143	
		113A	16.5	19.8	47	50	46	144	49	50	48	146	
114A		27.8	33.4	64	70	62	157	66	70	64	159		
HIGH	115A	33.0	39.7	72	80	69	164	74	80	71	166		
	114A+116A	41.7	50.2	85	90	81	224	87	90	83	226		
	NONE	–	–	22	25	23	124	24	30	25	126		
	116A	13.9	16.7	43	45	42	141	45	45	45	143		
	113A	16.5	19.8	47	50	46	144	49	50	48	146		
575 – 3 – 60	STD	NONE	–	–	15	20	15	79	19	20	20	83	
		118A	17.0	20.4	40	40	39	99	44	45	43	103	
		119A	34.0	40.9	66	70	62	120	70	70	67	124	
	MED	NONE	–	–	16	20	17	94	20	25	21	98	
		118A	17.0	20.4	42	45	40	114	45	45	45	118	
	HIGH	119A	34.0	40.9	67	70	64	135	71	80	68	139	
		NONE	–	–	16	20	17	94	20	25	21	98	
		118A	17.0	20.4	42	45	40	114	45	45	45	118	
		119A	34.0	40.9	67	70	64	135	71	80	68	139	

50TCQ

See Legend and Notes for Tables 67 – 108 on Page 113.

MCA/MOCP (cont.)

Table 100 – 50TCQD08

MCA/MOCP DETERMINATION WITH PWRD C.O. 2-STAGE COOLING WITH 2-SPEED INDOOR FAN MOTOR

UNIT	NOM. V – PH – HZ	IFM TYPE	ELEC. HTR			w/ PWRD C.O.							
			CRHEATER ****00	Nom (kW)	FLA	NO P.E.				w/ P.E. (pwrd fr/unit)			
						MCA	MAX FUSE or HACR BRKR	DISC. SIZE		MCA	MAX FUSE or HACR BRKR	DISC. SIZE	
								FLA	LRA			FLA	LRA
50TCQ	208/230 – 3 – 60	STD	NONE	–	–	44/43	50/50	46/46	202	47/47	60/50	50/50	206
			117A	7.8/10.4	21.7/25.0	71/75	80/80	71/74	224/227	74/78	80/80	75/79	228/231
			110A	12.0/16.0	33.4/38.5	85/91	90/100	84/90	235/241	89/95	90/100	89/94	239/245
			111A	18.6/24.8	51.7/59.7	108/118	110/125	105/114	254/262	112/122	125/125	110/119	258/266
			112A	24.0/32.0	66.7/77.0	127/140	150/150	122/134	269/279	131/143	150/150	127/138	273/283
		112A+117A	31.8/42.4	88.4/102.0	154/171	175/175	147/163	379/406	158/175	175/175	152/167	383/410	
		MED	NONE	–	–	46/46	50/50	49/48	232	50/49	60/60	53/52	236
			117A	7.8/10.4	21.7/25.0	73/77	80/80	74/77	254/257	77/81	80/90	78/81	258/261
			110A	12.0/16.0	33.4/38.5	88/94	90/100	87/92	265/271	92/97	100/100	92/97	269/275
			111A	18.6/24.8	51.7/59.7	111/120	125/125	108/117	284/292	115/124	125/125	113/121	288/296
			112A	24.0/32.0	66.7/77.0	130/142	150/150	126/137	299/309	134/146	150/150	130/141	303/313
		112A+117A	31.8/42.4	88.4/102.0	157/173	175/175	151/165	409/436	161/177	175/200	155/170	413/440	
		HIGH	NONE	–	–	46/46	50/50	49/48	232	50/49	60/60	53/52	236
			117A	7.8/10.4	21.7/25.0	73/77	80/80	74/77	254/257	77/81	80/90	78/81	258/261
			110A	12.0/16.0	33.4/38.5	88/94	90/100	87/92	265/271	92/97	100/100	92/97	269/275
	111A		18.6/24.8	51.7/59.7	111/120	125/125	108/117	284/292	115/124	125/125	113/121	288/296	
	112A		24.0/32.0	66.7/77.0	130/142	150/150	126/137	299/309	134/146	150/150	130/141	303/313	
	112A+117A	31.8/42.4	88.4/102.0	157/173	175/175	151/165	409/436	161/177	175/200	155/170	413/440		
50TCQD08	460 – 3 – 60	STD	NONE	–	–	21	25	22	99	23	25	24	101
			116A	13.9	16.7	42	45	41	116	44	45	43	118
			113A	16.5	19.8	46	50	45	119	47	50	47	121
			114A	27.8	33.4	63	70	60	132	64	70	62	134
			115A	33.0	39.7	71	80	67	139	72	80	69	141
		114A+116A	41.7	50.2	84	90	79	199	85	90	82	201	
	MED	NONE	–	–	22	25	23	115	24	25	25	117	
		116A	13.9	16.7	43	45	42	132	44	45	44	134	
		113A	16.5	19.8	47	50	46	135	48	50	48	137	
		114A	27.8	33.4	64	70	61	148	65	70	63	150	
		115A	33.0	39.7	71	80	68	155	73	80	70	157	
	114A+116A	41.7	50.2	85	90	81	215	86	90	83	217		
	HIGH	NONE	–	–	22	25	23	115	24	25	25	117	
		116A	13.9	16.7	43	45	42	132	44	45	44	134	
		113A	16.5	19.8	47	50	46	135	48	50	48	137	
114A		27.8	33.4	64	70	61	148	65	70	63	150		
115A		33.0	39.7	71	80	68	155	73	80	70	157		
114A+116A	41.7	50.2	85	90	81	215	86	90	83	217			
575 – 3 – 60	STD	NONE	–	–	16	20	17	81	20	25	21	85	
		118A	17.0	20.4	42	45	40	101	45	45	45	105	
		119A	34.0	40.9	67	70	64	122	71	80	68	126	
	MED	NONE	–	–	18	20	19	94	22	25	23	98	
		118A	17.0	20.4	43	45	42	114	47	50	46	118	
		119A	34.0	40.9	69	70	66	135	73	80	70	139	
	HIGH	NONE	–	–	18	20	19	94	22	25	23	98	
		118A	17.0	20.4	43	45	42	114	47	50	46	118	
		119A	34.0	40.9	69	70	66	135	73	80	70	139	

See Legend and Notes for Tables 67 – 108 on Page 113.

MCA/MOCP (cont.)

Table 101 – 50TCQD09

MCA/MOCP DETERMINATION WITH PWRD C.O. 2-STAGE COOLING WITH SINGLE SPEED INDOOR FAN MOTOR (Units Produced On or After 02/09/2015)

UNIT	NOM. V-PH-HZ	IFM TYPE	ELEC. HTR			w/ PWRD C.O.							
			CRHEATER ****00	Nom (kW)	FLA	NO P.E.				w/ P.E. (pwrd fr/unit)			
						MCA	MAX FUSE or HACR BRKR	DISC. SIZE		MCA	MAX FUSE or HACR BRKR	DISC. SIZE	
								FLA	LRA			FLA	LRA
50TCQD09	208/230-3-60	STD	NONE	-	-	45/45	50/50	47/47	230	49/49	60/60	52/51	234
			117A	7.8/10.4	21.7/25.0	72/76	80/80	72/76	252/255	76/80	80/80	77/80	256/259
			110A	12.0/16.0	33.4/38.5	87/93	90/100	86/91	263/269	91/97	100/100	90/96	267/273
			111A	18.6/24.8	51.7/59.7	110/120	110/125	107/116	282/290	114/123	125/125	111/120	286/294
			112A	24.0/32.0	66.7/77.0	129/141	150/150	124/136	297/307	132/145	150/150	128/140	301/311
			112A+117A	31.8/42.4	88.4/102.0	156/172	175/175	149/164	407/434	160/176	175/200	153/169	411/438
		MED	NONE	-	-	48/48	60/60	51/51	266	52/52	60/60	55/55	270
			117A	7.8/10.4	21.7/25.0	76/80	80/80	76/80	288/291	79/83	80/90	80/84	292/295
			110A	12.0/16.0	33.4/38.5	90/97	90/100	89/95	299/305	94/100	100/100	94/100	303/309
			111A	18.6/24.8	51.7/59.7	113/123	125/125	111/120	318/326	117/127	125/150	115/124	322/330
			112A	24.0/32.0	66.7/77.0	132/145	150/150	128/139	333/343	136/148	150/150	132/144	337/347
			112A+117A	31.8/42.4	88.4/102.0	159/176	175/200	153/168	443/470	163/180	175/200	157/173	447/474
	HIGH	NONE	-	-	48/48	60/60	51/51	266	52/52	60/60	55/55	270	
		117A	7.8/10.4	21.7/25.0	76/80	80/80	76/80	288/291	79/83	80/90	80/84	292/295	
		110A	12.0/16.0	33.4/38.5	90/97	90/100	89/95	299/305	94/100	100/100	94/100	303/309	
		111A	18.6/24.8	51.7/59.7	113/123	125/125	111/120	318/326	117/127	125/150	115/124	322/330	
		112A	24.0/32.0	66.7/77.0	132/145	150/150	128/139	333/343	136/148	150/150	132/144	337/347	
		112A+117A	31.8/42.4	88.4/102.0	159/176	175/200	153/168	443/470	163/180	175/200	157/173	447/474	
	460-3-60	STD	NONE	-	-	21	25	22	120	23	25	24	122
			116A	13.9	16.7	42	45	41	137	44	45	43	139
			113A	16.5	19.8	46	50	44	140	47	50	46	142
			114A	27.8	33.4	63	70	60	153	64	70	62	155
			115A	33.0	39.7	70	80	67	160	72	80	69	162
			114A+116A	41.7	50.2	84	90	79	220	85	90	81	222
MED		NONE	-	-	23	25	24	138	24	30	26	140	
		116A	13.9	16.7	43	45	43	155	45	45	45	157	
		113A	16.5	19.8	47	50	46	158	49	50	48	160	
		114A	27.8	33.4	64	70	62	171	66	70	64	173	
		115A	33.0	39.7	72	80	69	178	74	80	71	180	
		114A+116A	41.7	50.2	85	90	81	238	87	90	83	240	
HIGH		NONE	-	-	23	25	24	138	24	30	26	140	
		116A	13.9	16.7	43	45	43	155	45	45	45	157	
		113A	16.5	19.8	47	50	46	158	49	50	48	160	
		114A	27.8	33.4	64	70	62	171	66	70	64	173	
		115A	33.0	39.7	72	80	69	178	74	80	71	180	
		114A+116A	41.7	50.2	85	90	81	238	87	90	83	240	
575-3-60	STD	NONE	-	-	17	20	18	87	21	25	22	91	
		118A	17.0	20.4	43	45	41	107	47	50	45	111	
		119A	34.0	40.9	68	70	65	128	72	80	69	132	
	MED	NONE	-	-	18	20	19	102	22	25	23	106	
		118A	17.0	20.4	44	45	42	122	48	50	47	126	
		119A	34.0	40.9	70	70	66	143	73	80	70	147	
	HIGH	NONE	-	-	18	20	19	102	22	25	23	106	
		118A	17.0	20.4	44	45	42	122	48	50	47	126	
		119A	34.0	40.9	70	70	66	143	73	80	70	147	

50TCQ

See Legend and Notes for Tables 67 – 108 on Page 113.

MCA/MOCP (cont.)

Table 102 – 50TCQD09

**MCA/MOCP DETERMINATION WITH PWRD C.O.
2-STAGE COOLING WITH SINGLE SPEED INDOOR FAN MOTOR
(Units Produced on or Prior to 02/08/2015)**

UNIT	NOM. V-PH-HZ	IFM TYPE	ELEC. HTR			w/ PWRD C.O.							
			CRHEATER ****00	Nom (kW)	FLA	NO P.E.				w/ P.E. (pwrd fr/unit)			
						MCA	MAX FUSE or HACR BRKR	DISC. SIZE		MCA	MAX FUSE or HACR BRKR	DISC. SIZE	
								FLA	LRA			FLA	LRA
50TCQ	208/230-3-60	STD	NONE	–	–	45/45	50/50	47/47	230	49/49	60/60	52/51	234
			117A	7.8/10.4	21.7/25.0	72/76	80/80	72/76	252/255	76/80	80/80	77/80	256/259
			110A	12.0/16.0	33.4/38.5	87/93	90/100	86/91	263/269	91/97	100/100	90/96	267/273
			111A	18.6/24.8	51.7/59.7	110/120	110/125	107/116	282/290	114/123	125/125	111/120	286/294
			112A	24.0/32.0	66.7/77.0	129/141	150/150	124/136	297/307	132/145	150/150	128/140	301/311
			112A+117A	31.8/42.4	88.4/102.0	156/172	175/175	149/164	407/434	160/176	175/200	153/169	411/438
		MED	NONE	–	–	48/48	60/60	51/51	266	52/52	60/60	55/55	270
			117A	7.8/10.4	21.7/25.0	76/80	80/80	76/80	288/291	79/83	80/90	80/84	292/295
			110A	12.0/16.0	33.4/38.5	90/97	90/100	89/95	299/305	94/100	100/100	94/100	303/309
			111A	18.6/24.8	51.7/59.7	113/123	125/125	111/120	318/326	117/127	125/150	115/124	322/330
			112A	24.0/32.0	66.7/77.0	132/145	150/150	128/139	333/343	136/148	150/150	132/144	337/347
			112A+117A	31.8/42.4	88.4/102.0	159/176	175/200	153/168	443/470	163/180	175/200	157/173	447/474
		HIGH	NONE	–	–	48/48	60/60	51/51	266	52/52	60/60	55/55	270
			117A	7.8/10.4	21.7/25.0	76/80	80/80	76/80	288/291	79/83	80/90	80/84	292/295
			110A	12.0/16.0	33.4/38.5	90/97	90/100	89/95	299/305	94/100	100/100	94/100	303/309
			111A	18.6/24.8	51.7/59.7	113/123	125/125	111/120	318/326	117/127	125/150	115/124	322/330
			112A	24.0/32.0	66.7/77.0	132/145	150/150	128/139	333/343	136/148	150/150	132/144	337/347
			112A+117A	31.8/42.4	88.4/102.0	159/176	175/200	153/168	443/470	163/180	175/200	157/173	447/474
50TCQD09	460-3-60	STD	NONE	–	–	21	25	22	120	23	25	24	122
			116A	13.9	16.7	42	45	41	137	44	45	43	139
			113A	16.5	19.8	46	50	44	140	47	50	46	142
			114A	27.8	33.4	63	70	60	153	64	70	62	155
			115A	33.0	39.7	70	80	67	160	72	80	69	162
			114A+116A	41.7	50.2	84	90	79	220	85	90	81	222
		MED	NONE	–	–	23	25	24	138	24	30	26	140
			116A	13.9	16.7	43	45	43	155	45	45	45	157
			113A	16.5	19.8	47	50	46	158	49	50	48	160
			114A	27.8	33.4	64	70	62	171	66	70	64	173
			115A	33.0	39.7	72	80	69	178	74	80	71	180
			114A+116A	41.7	50.2	85	90	81	238	87	90	83	240
		HIGH	NONE	–	–	23	25	24	138	24	30	26	140
			116A	13.9	16.7	43	45	43	155	45	45	45	157
			113A	16.5	19.8	47	50	46	158	49	50	48	160
			114A	27.8	33.4	64	70	62	171	66	70	64	173
			115A	33.0	39.7	72	80	69	178	74	80	71	180
			114A+116A	41.7	50.2	85	90	81	238	87	90	83	240
50TCQD09	575-3-60	STD	NONE	–	–	17	20	18	87	21	25	22	91
			118A	17.0	20.4	43	45	41	107	47	50	45	111
			119A	34.0	40.9	68	70	65	128	72	80	69	132
		MED	NONE	–	–	18	20	19	102	22	25	23	106
			118A	17.0	20.4	44	45	42	122	48	50	47	126
			119A	34.0	40.9	70	70	66	143	73	80	70	147
		HIGH	NONE	–	–	18	20	19	102	22	25	23	106
			118A	17.0	20.4	44	45	42	122	48	50	47	126
			119A	34.0	40.9	70	70	66	143	73	80	70	147

See Legend and Notes for Tables 67 – 108 on Page 113.

MCA/MOCP (cont.)

Table 103 – 50TCQD09

MCA/MOCP DETERMINATION WITH PWRD C.O. 2-STAGE COOLING WITH 2-SPEED INDOOR FAN MOTOR

(Units Produced On or After 02/09/2015)

UNIT	NOM. V-PH-HZ	IFM TYPE	ELEC. HTR			w/ PWRD C.O.							
			CRHEATER ****00	Nom (kW)	FLA	NO P.E.				w/ P.E. (pwrd fr/unit)			
						MCA	MAX FUSE or HACR BRKR	DISC. SIZE		MCA	MAX FUSE or HACR BRKR	DISC. SIZE	
								FLA	LRA			FLA	LRA
50TCQD09	208/230-3-60	STD	NONE	–	–	46/46	50/50	48/48	217	50/49	60/60	52/52	221
			117A	7.8/10.4	21.7/25.0	73/77	80/80	73/77	239/242	77/81	80/90	77/81	243/246
			110A	12.0/16.0	33.4/38.5	88/94	90/100	86/92	250/256	91/98	100/100	91/96	254/260
			111A	18.6/24.8	51.7/59.7	111/120	125/125	108/116	269/277	114/124	125/125	112/121	273/281
			112A	24.0/32.0	66.7/77.0	129/142	150/150	125/136	284/294	133/146	150/150	129/141	288/298
			112A+117A	31.8/42.4	88.4/102.0	156/173	175/175	150/165	394/421	160/177	175/200	154/170	398/425
		MED	NONE	–	–	49/48	60/60	51/50	247	52/52	60/60	56/55	251
			117A	7.8/10.4	21.7/25.0	76/79	80/80	76/79	269/272	80/83	80/90	81/83	273/276
			110A	12.0/16.0	33.4/38.5	90/96	90/100	90/95	280/286	94/100	100/100	94/99	284/290
			111A	18.6/24.8	51.7/59.7	113/123	125/125	111/119	299/307	117/126	125/150	115/123	303/311
			112A	24.0/32.0	66.7/77.0	132/144	150/150	128/139	314/324	136/148	150/150	132/143	318/328
			112A+117A	31.8/42.4	88.4/102.0	159/175	175/175	153/168	424/451	163/179	175/200	157/172	428/455
		HIGH	NONE	–	–	49/48	60/60	51/50	247	52/52	60/60	56/55	251
			117A	7.8/10.4	21.7/25.0	76/79	80/80	76/79	269/272	80/83	80/90	81/83	273/276
			110A	12.0/16.0	33.4/38.5	90/96	90/100	90/95	280/286	94/100	100/100	94/99	284/290
	111A		18.6/24.8	51.7/59.7	113/123	125/125	111/119	299/307	117/126	125/150	115/123	303/311	
	112A		24.0/32.0	66.7/77.0	132/144	150/150	128/139	314/324	136/148	150/150	132/143	318/328	
	112A+117A		31.8/42.4	88.4/102.0	159/175	175/175	153/168	424/451	163/179	175/200	157/172	428/455	
	460-3-60	STD	NONE	–	–	21	25	22	113	23	25	24	115
			116A	13.9	16.7	42	45	41	130	44	45	43	132
			113A	16.5	19.8	46	50	45	133	48	50	47	135
			114A	27.8	33.4	63	70	60	146	65	70	63	148
			115A	33.0	39.7	71	80	68	153	73	80	70	155
			114A+116A	41.7	50.2	84	90	80	213	86	90	82	215
MED		NONE	–	–	22	25	23	129	24	30	25	131	
		116A	13.9	16.7	43	45	42	146	45	45	44	148	
		113A	16.5	19.8	47	50	46	149	49	50	48	151	
		114A	27.8	33.4	64	70	62	162	66	70	64	164	
		115A	33.0	39.7	72	80	69	169	74	80	71	171	
		114A+116A	41.7	50.2	85	90	81	229	87	90	83	231	
HIGH		NONE	–	–	22	25	23	129	24	30	25	131	
		116A	13.9	16.7	43	45	42	146	45	45	44	148	
		113A	16.5	19.8	47	50	46	149	49	50	48	151	
		114A	27.8	33.4	64	70	62	162	66	70	64	164	
		115A	33.0	39.7	72	80	69	169	74	80	71	171	
		114A+116A	41.7	50.2	85	90	81	229	87	90	83	231	
575-3-60	STD	NONE	–	–	18	20	19	89	22	25	23	93	
		118A	17.0	20.4	44	45	42	109	48	50	47	113	
		119A	34.0	40.9	70	70	66	130	73	80	70	134	
	MED	NONE	–	–	20	25	21	102	24	30	25	106	
		118A	17.0	20.4	46	50	44	122	49	50	49	126	
		119A	34.0	40.9	71	80	68	143	75	80	72	147	
	HIGH	NONE	–	–	20	25	21	102	24	30	25	106	
		118A	17.0	20.4	46	50	44	122	49	50	49	126	
		119A	34.0	40.9	71	80	68	143	75	80	72	147	

50TCQ

See Legend and Notes for Tables 67 – 108 on Page 113.

MCA/MOCP (cont.)

Table 104 – 50TCQD09

**MCA/MOCP DETERMINATION WITH PWRD C.O.
2-STAGE COOLING WITH 2-SPEED INDOOR FAN MOTOR**

(Units Produced on or Prior to 02/08/2015)

UNIT	NOM. V-PH-HZ	IFM TYPE	ELEC. HTR			w/ PWRD C.O.							
			CRHEATER ****00	Nom (kW)	FLA	NO P.E.				w/ P.E. (pwrd fr/unit)			
						MCA	MAX FUSE or HACR BRKR	DISC. SIZE		MCA	MAX FUSE or HACR BRKR	DISC. SIZE	
								FLA	LRA			FLA	LRA
50TCQ	208/230-3-60	STD	NONE	–	–	46/46	50/50	48/48	217	50/49	60/60	52/52	221
			117A	7.8/10.4	21.7/25.0	73/77	80/80	73/77	239/242	77/81	80/90	77/81	243/246
			110A	12.0/16.0	33.4/38.5	88/94	90/100	86/92	250/256	91/98	100/100	91/96	254/260
			111A	18.6/24.8	51.7/59.7	111/120	125/125	108/116	269/277	114/124	125/125	112/121	273/281
			112A	24.0/32.0	66.7/77.0	129/142	150/150	125/136	284/294	133/146	150/150	129/141	288/298
			112A+117A	31.8/42.4	88.4/102.0	156/173	175/175	150/165	394/421	160/177	175/200	154/170	398/425
		MED	NONE	–	–	49/48	60/60	51/50	247	52/52	60/60	56/55	251
			117A	7.8/10.4	21.7/25.0	76/79	80/80	76/79	269/272	80/83	80/90	81/83	273/276
			110A	12.0/16.0	33.4/38.5	90/96	90/100	90/95	280/286	94/100	100/100	94/99	284/290
			111A	18.6/24.8	51.7/59.7	113/123	125/125	111/119	299/307	117/126	125/150	115/123	303/311
			112A	24.0/32.0	66.7/77.0	132/144	150/150	128/139	314/324	136/148	150/150	132/143	318/328
			112A+117A	31.8/42.4	88.4/102.0	159/175	175/175	153/168	424/451	163/179	175/200	157/172	428/455
		HIGH	NONE	–	–	49/48	60/60	51/50	247	52/52	60/60	56/55	251
			117A	7.8/10.4	21.7/25.0	76/79	80/80	76/79	269/272	80/83	80/90	81/83	273/276
			110A	12.0/16.0	33.4/38.5	90/96	90/100	90/95	280/286	94/100	100/100	94/99	284/290
			111A	18.6/24.8	51.7/59.7	113/123	125/125	111/119	299/307	117/126	125/150	115/123	303/311
			112A	24.0/32.0	66.7/77.0	132/144	150/150	128/139	314/324	136/148	150/150	132/143	318/328
			112A+117A	31.8/42.4	88.4/102.0	159/175	175/175	153/168	424/451	163/179	175/200	157/172	428/455
50TCQD09	460-3-60	STD	NONE	–	–	21	25	22	113	23	25	24	115
			116A	13.9	16.7	42	45	41	130	44	45	43	132
			113A	16.5	19.8	46	50	45	133	48	50	47	135
			114A	27.8	33.4	63	70	60	146	65	70	63	148
			115A	33.0	39.7	71	80	68	153	73	80	70	155
			114A+116A	41.7	50.2	84	90	80	213	86	90	82	215
		MED	NONE	–	–	22	25	23	129	24	30	25	131
			116A	13.9	16.7	43	45	42	146	45	45	44	148
			113A	16.5	19.8	47	50	46	149	49	50	48	151
			114A	27.8	33.4	64	70	62	162	66	70	64	164
			115A	33.0	39.7	72	80	69	169	74	80	71	171
			114A+116A	41.7	50.2	85	90	81	229	87	90	83	231
		HIGH	NONE	–	–	22	25	23	129	24	30	25	131
			116A	13.9	16.7	43	45	42	146	45	45	44	148
			113A	16.5	19.8	47	50	46	149	49	50	48	151
			114A	27.8	33.4	64	70	62	162	66	70	64	164
			115A	33.0	39.7	72	80	69	169	74	80	71	171
			114A+116A	41.7	50.2	85	90	81	229	87	90	83	231
50TCQD09	575-3-60	STD	NONE	–	–	18	20	19	89	22	25	23	93
			118A	17.0	20.4	44	45	42	109	48	50	47	113
			119A	34.0	40.9	70	70	66	130	73	80	70	134
		MED	NONE	–	–	20	25	21	102	24	30	25	106
			118A	17.0	20.4	46	50	44	122	49	50	49	126
			119A	34.0	40.9	71	80	68	143	75	80	72	147
		HIGH	NONE	–	–	20	25	21	102	24	30	25	106
			118A	17.0	20.4	46	50	44	122	49	50	49	126
			119A	34.0	40.9	71	80	68	143	75	80	72	147

See Legend and Notes for Tables 67 – 108 on Page 113.

MCA/MOCP (cont.)

Table 105 – 50TCQD12

MCA/MOCP DETERMINATION WITH PWRD C.O. 2-STAGE COOLING WITH SINGLE SPEED INDOOR FAN MOTOR

UNIT	NOM. V – PH – HZ	IFM TYPE	ELEC. HTR			w/ PWRD C.O.							
			CRHEATER *****00	Nom (kW)	FLA	NO P.E.				w/ P.E. (pwrd fr/unit)			
						MCA	MAX FUSE or HACR BRKR	DISC. SIZE		MCA	MAX FUSE or HACR BRKR	DISC. SIZE	
								FLA	LRA			FLA	LRA
50TCQD12	208/230 – 3 – 60	STD	NONE	–	–	54/54	60/60	57/57	314	58/57	70/70	61/61	318
			117A	7.8/10.4	21.7/25.0	81/85	90/90	82/85	336/339	85/89	90/90	86/90	340/343
			110A	12.0/16.0	33.4/38.5	96/102	100/110	95/101	347/353	99/106	100/110	100/105	351/357
			112A	24.0/32.0	66.7/77.0	137/150	150/150	134/145	381/391	141/154	150/175	138/150	385/395
			112A+117A	31.8/42.4	88.4/102.0	164/181	175/200	158/174	491/518	168/185	175/200	163/178	495/522
		112A+110A	37.6/50.0	104.2/120.3	184/174	200/200	177/195	522/555	188/178	200/200	181/199	526/559	
		MED	NONE	–	–	58	70	61	343	61	70	65	347
			117A	7.8/10.4	21.7/25.0	85/89	90/90	86/90	365/368	88/93	90/100	90/94	369/372
			110A	12.0/16.0	33.4/38.5	99/106	100/110	99/105	376/382	103/109	110/110	104/110	380/386
			112A	24.0/32.0	66.7/77.0	141/154	150/175	138/150	410/420	145/158	150/175	142/154	414/424
			112A+117A	31.8/42.4	88.4/102.0	168/185	175/200	163/178	520/547	172/189	175/200	167/183	524/551
		112A+110A	37.6/50.0	104.2/120.3	188/178	200/200	181/199	551/584	192/182	200/200	185/204	555/588	
		HIGH	NONE	–	–	61/60	70/70	65/63	345	64/63	70/70	69/68	349
			117A	7.8/10.4	21.7/25.0	88/91	90/100	89/92	367/370	91/95	100/100	94/97	371/374
			110A	12.0/16.0	33.4/38.5	102/108	110/110	103/108	378/384	106/112	110/125	107/112	382/388
112A	24.0/32.0		66.7/77.0	144/156	150/175	141/152	412/422	148/160	150/175	146/156	416/426		
112A+117A	31.8/42.4		88.4/102.0	171/187	175/200	166/181	522/549	175/191	175/200	171/185	526/553		
112A+110A	37.6/50.0	104.2/120.3	191/180	200/200	184/202	553/586	195/184	200/200	189/206	557/590			
50TCQD12	460 – 3 – 60	STD	NONE	–	–	26	30	28	150	28	30	30	152
			116A	13.9	16.7	47	50	47	167	49	50	49	169
			113A	16.5	19.8	51	60	50	170	53	60	53	172
			115A	33.0	39.7	76	80	73	190	78	80	75	192
			114A+116A	41.7	50.2	89	90	85	250	91	100	88	252
		115A+113A	50.0	60.1	87	90	97	270	88	90	99	272	
		MED	NONE	–	–	28	30	30	165	30	35	32	167
			116A	13.9	16.7	49	50	49	182	51	60	51	184
			113A	16.5	19.8	53	60	53	185	55	60	55	187
			115A	33.0	39.7	78	80	76	205	80	80	78	207
			114A+116A	41.7	50.2	91	100	88	265	93	100	90	267
		115A+113A	50.0	60.1	88	90	99	285	90	100	101	287	
		HIGH	NONE	–	–	29	35	31	166	31	35	33	168
			116A	13.9	16.7	50	50	50	183	52	60	52	185
			113A	16.5	19.8	54	60	54	186	56	60	56	188
115A	33.0		39.7	79	80	77	206	81	90	79	208		
114A+116A	41.7		50.2	92	100	89	266	94	100	91	268		
115A+113A	50.0	60.1	90	100	100	286	91	100	102	288			
50TCQD12	575 – 3 – 60	STD	NONE	–	–	20	25	20	107	23	25	25	111
			118A	17.0	20.4	45	45	44	127	49	50	48	131
			119A	34.0	40.9	71	80	67	148	75	80	72	152
			118A+119A	51.0	61.3	81	90	91	230	85	90	95	234
		MED	NONE	–	–	20	25	21	118	24	30	26	122
			118A	17.0	20.4	46	50	45	138	50	50	49	142
			119A	34.0	40.9	72	80	68	159	75	80	73	163
			118A+119A	51.0	61.3	82	90	92	241	86	90	96	245
		HIGH	NONE	–	–	23	25	24	132	27	30	29	136
			118A	17.0	20.4	49	50	48	152	53	60	52	156
			119A	34.0	40.9	74	80	72	173	78	80	76	177
			118A+119A	51.0	61.3	85	90	95	255	88	90	99	259

50TCQ

See Legend and Notes for Tables 67 – 108 on Page 113.

MCA/MOCP (cont.)

Table 106 – 50TCQD12

MCA/MOCP DETERMINATION WITH PWRD C.O. 2-STAGE COOLING WITH 2-SPEED INDOOR FAN MOTOR

UNIT	NOM. V – PH – HZ	IFM TYPE	ELEC. HTR			w/ PWRD C.O.								
			CRHEATER *****00	Nom (kW)	FLA	NO P.E.				w/ P.E. (pwrd fr/unit)				
						MCA	MAX FUSE or HACR BRKR	DISC. SIZE		MCA	MAX FUSE or HACR BRKR	DISC. SIZE		
								FLA	LRA			FLA	LRA	
50TCQ	208/230 – 3 – 60	STD	NONE	–	–	54/54	60/60	57/57	284	58/58	70/70	61/61	288	
			117A	7.8/10.4	21.7/25.0	81/85	90/90	82/85	306/309	85/89	90/90	86/90	310/313	
			110A	12.0/16.0	33.4/38.5	96/102	100/110	95/101	317/323	100/106	100/110	100/105	321/327	
			112A	24.0/32.0	66.7/77.0	137/150	150/150	134/145	351/361	141/154	150/175	138/150	355/365	
			112A+117A	31.8/42.4	88.4/102.0	165/181	175/200	159/174	461/488	168/185	175/200	163/178	465/492	
		112A+110A	37.6/50.0	104.2/120.3	184/174	200/200	177/195	492/525	188/178	200/200	181/199	496/529		
		MED	NONE	–	–	58/57	70/70	61/60	334	62/61	70/70	66/65	338	
			117A	7.8/10.4	21.7/25.0	85/88	90/90	86/89	356/359	89/92	90/100	91/93	360/363	
			110A	12.0/16.0	33.4/38.5	99/105	100/110	100/104	367/373	103/109	110/110	104/109	371/377	
			112A	24.0/32.0	66.7/77.0	141/153	150/175	138/149	401/411	145/157	150/175	142/153	405/415	
			112A+117A	31.8/42.4	88.4/102.0	168/184	175/200	163/177	511/538	172/188	175/200	167/182	515/542	
		112A+110A	37.6/50.0	104.2/120.3	188/177	200/200	181/198	542/575	192/181	200/200	185/203	546/579		
		HIGH	NONE	–	–	61/60	70/70	65/63	345	64/63	70/70	69/68	349	
			117A	7.8/10.4	21.7/25.0	88/91	90/100	89/92	367/370	91/95	100/100	94/97	371/374	
			110A	12.0/16.0	33.4/38.5	102/108	110/110	103/108	378/384	106/112	110/125	107/112	382/388	
	112A		24.0/32.0	66.7/77.0	144/156	150/175	141/152	412/422	148/160	150/175	146/156	416/426		
	112A+117A		31.8/42.4	88.4/102.0	171/187	175/200	166/181	522/549	175/191	175/200	171/185	526/553		
	112A+110A	37.6/50.0	104.2/120.3	191/180	200/200	184/202	553/586	195/184	200/200	189/206	557/590			
	50TCQD12	460 – 3 – 60	STD	NONE	–	–	27	30	28	136	29	35	30	138
				116A	13.9	16.7	48	50	47	153	50	50	49	155
				113A	16.5	19.8	52	60	51	156	53	60	53	158
				115A	33.0	39.7	77	80	74	176	78	80	76	178
				114A+116A	41.7	50.2	90	90	86	236	91	100	88	238
			115A+113A	50.0	60.1	87	90	97	256	89	100	99	258	
MED		NONE	–	–	28	30	29	161	30	35	32	163		
		116A	13.9	16.7	49	50	49	178	51	60	51	180		
		113A	16.5	19.8	53	60	52	181	55	60	54	183		
		115A	33.0	39.7	78	80	75	201	79	80	77	203		
		114A+116A	41.7	50.2	91	100	87	261	93	100	89	263		
115A+113A		50.0	60.1	88	90	99	281	90	100	101	283			
HIGH		NONE	–	–	29	35	31	166	31	35	33	168		
		116A	13.9	16.7	50	50	50	183	52	60	52	185		
		113A	16.5	19.8	54	60	54	186	56	60	56	188		
	115A	33.0	39.7	79	80	77	206	81	90	79	208			
	114A+116A	41.7	50.2	92	100	89	266	94	100	91	268			
115A+113A	50.0	60.1	90	100	100	286	91	100	102	288				
575 – 3 – 60	STD	NONE	–	–	21	25	22	109	25	30	26	113		
		118A	17.0	20.4	47	50	46	129	50	50	50	133		
		119A	34.0	40.9	72	80	69	150	76	80	73	154		
		118A+119A	51.0	61.3	82	90	93	232	86	90	97	236		
	MED	NONE	–	–	22	25	23	118	26	30	28	122		
		118A	17.0	20.4	48	50	47	138	51	60	51	142		
		119A	34.0	40.9	73	80	70	159	77	80	75	163		
		118A+119A	51.0	61.3	83	90	94	241	87	90	98	245		
	HIGH	NONE	–	–	24	30	25	132	28	30	30	136		
		118A	17.0	20.4	49	50	49	152	53	60	53	156		
		119A	34.0	40.9	75	80	72	173	79	80	77	177		
		118A+119A	51.0	61.3	85	90	96	255	89	100	100	259		

See Legend and Notes for Tables 67 – 108 on Page 113.

MCA/MOCP (cont.)

Table 107 – 50TCQD14

MCA/MOCP DETERMINATION WITH PWRD C.O. 2-STAGE COOLING WITH SINGLE SPEED INDOOR FAN MOTOR

UNIT	NOM. V – PH – HZ	IFM TYPE	ELEC. HTR			w/ PWRD C.O.							
			CRHEATER *****00	Nom (kW)	FLA	NO P.E.				w/ P.E. (pwrd fr/unit)			
						MCA	MAX FUSE or HACR BRKR	DISC. SIZE		MCA	MAX FUSE or HACR BRKR	DISC. SIZE	
								FLA	LRA			FLA	LRA
50TCQD14	208/230 – 3 – 60	STD	NONE	–	–	69/68	80/80	72/72	387	72/72	80/80	76/76	391
			291A	12.4/16.5	34.4/39.7	112/118	125/125	111/117	421/427	115/122	125/125	116/122	425/431
			288A+291A	19.9/26.5	55.3/63.8	138/148	150/150	135/145	498/515	141/152	150/175	140/150	502/519
			294A	25.2/33.5	69.9/80.6	156/169	175/175	152/164	457/468	160/173	175/175	157/169	461/472
			288A+294A	32.7/43.5	90.7/104.7	182/199	200/200	176/192	568/596	186/203	200/225	181/197	572/600
		291A+294A	37.6/50.0	104.3/120.3	199/189	200/200	192/210	596/628	203/193	225/200	196/214	600/632	
		MED	NONE	–	–	69/68	80/80	72/72	387	72/72	80/80	76/76	391
			291A	12.4/16.5	34.4/39.7	112/118	125/125	111/117	421/427	115/122	125/125	116/122	425/431
			288A+291A	19.9/26.5	55.3/63.8	138/148	150/150	135/145	498/515	141/152	150/175	140/150	502/519
	294A		25.2/33.5	69.9/80.6	156/169	175/175	152/164	457/468	160/173	175/175	157/169	461/472	
	288A+294A		32.7/43.5	90.7/104.7	182/199	200/200	176/192	568/596	186/203	200/225	181/197	572/600	
	291A+294A	37.6/50.0	104.3/120.3	199/189	200/200	192/210	596/628	203/193	225/200	196/214	600/632		
	HIGH	NONE	–	–	81	100	86	407	84	100	90	411	
		291A	12.4/16.5	34.4/39.7	124/130	125/150	125/131	441/447	127/134	150/150	130/136	445/451	
		288A+291A	19.9/26.5	55.3/63.8	150/160	150/175	149/159	518/535	153/164	175/175	154/163	522/539	
294A		25.2/33.5	69.9/80.6	168/181	175/200	166/178	477/488	172/185	175/200	170/183	481/492		
288A+294A		32.7/43.5	90.7/104.7	194/211	200/225	190/206	588/616	198/215	200/225	194/210	592/620		
291A+294A	37.6/50.0	104.3/120.3	211/201	225/225	206/224	616/648	215/205	225/225	210/228	620/652			
50TCQD14	460 – 3 – 60	STD	NONE	–	–	33	40	35	194	35	45	37	196
			292A	16.5	19.9	58	60	57	214	60	60	59	216
			289A+292A	26.5	31.9	73	80	71	258	75	80	73	260
			295A	33.5	40.3	83	90	81	234	85	90	83	236
			289A+295A	43.5	52.3	98	100	95	299	100	100	97	301
		292A+295A	50.0	60.2	93	100	104	314	95	100	106	316	
		MED	NONE	–	–	33	40	35	194	35	45	37	196
			292A	16.5	19.9	58	60	57	214	60	60	59	216
			289A+292A	26.5	31.9	73	80	71	258	75	80	73	260
	295A		33.5	40.3	83	90	81	234	85	90	83	236	
	289A+295A		43.5	52.3	98	100	95	299	100	100	97	301	
	292A+295A	50.0	60.2	93	100	104	314	95	100	106	316		
	HIGH	NONE	–	–	39	45	41	204	41	50	43	206	
		292A	16.5	19.9	64	70	64	224	66	70	66	226	
		289A+292A	26.5	31.9	79	80	78	268	81	90	80	270	
295A		33.5	40.3	89	90	88	244	91	100	90	246		
289A+295A		43.5	52.3	104	110	102	309	106	110	104	311		
292A+295A	50.0	60.2	99	110	111	324	101	110	113	326			
50TCQD14	575 – 3 – 60	STD	NONE	–	–	26	30	27	138	30	35	32	142
			293A	16.5	15.9	46	50	45	154	50	50	50	158
			290A+293A	26.5	25.5	58	60	56	189	62	70	61	193
			296A	33.5	32.2	66	70	64	170	70	70	69	174
			290A+296A	43.5	41.8	78	80	75	222	82	90	80	226
		293A+296A	50.0	48.1	74	80	82	234	78	80	87	238	
		MED	NONE	–	–	26	30	27	138	30	35	32	142
			293A	16.5	15.9	46	50	45	154	50	50	50	158
			290A+293A	26.5	25.5	58	60	56	189	62	70	61	193
	296A		33.5	32.2	66	70	64	170	70	70	69	174	
	290A+296A		43.5	41.8	78	80	75	222	82	90	80	226	
	293A+296A	50.0	48.1	74	80	82	234	78	80	87	238		
	HIGH	NONE	–	–	33	40	34	150	36	40	39	154	
		293A	16.5	15.9	52	60	53	166	56	60	57	170	
		290A+293A	26.5	25.5	64	70	64	201	68	70	68	205	
296A		33.5	32.2	73	80	71	182	77	80	76	186		
290A+296A		43.5	41.8	85	90	82	234	89	90	87	238		
293A+296A	50.0	48.1	81	90	90	246	84	90	94	250			

50TCQ

See Legend and Notes for Tables 67 – 108 on Page 113.

MCA/MOCP (cont.)

Table 108 – 50TCQD14

MCA/MOCP DETERMINATION WITH PWRD C.O. 2-STAGE COOLING WITH 2-SPEED INDOOR FAN MOTOR

UNIT	NOM. V – PH – HZ	IFM TYPE	ELEC. HTR			w/ PWRD C.O.							
			CRHEATER ****00	Nom (kW)	FLA	NO P.E.				w/ P.E. (pwrd fr/unit)			
						MCA	MAX FUSE or HACR BRKR	DISC. SIZE		MCA	MAX FUSE or HACR BRKR	DISC. SIZE	
								FLA	LRA			FLA	LRA
50TCQ	208/230 – 3 – 60	STD	NONE	–	–	69/68	80/80	72/71	368	73/72	80/80	76/76	372
			291A	12.4/16.5	34.4/39.7	112/118	125/125	112/117	402/408	116/121	125/125	116/121	406/412
			288A+291A	19.9/26.5	55.3/63.8	138/148	150/150	136/145	479/496	142/152	150/175	140/149	483/500
			294A	25.2/33.5	69.9/80.6	156/169	175/175	152/164	438/449	160/173	175/175	157/168	442/453
			288A+294A	32.7/43.5	90.7/104.7	182/199	200/200	176/192	549/577	186/203	200/225	181/196	553/581
		291A+294A	37.6/50.0	104.3/120.3	199/188	200/200	192/210	577/609	203/192	225/200	196/214	581/613	
		MED	NONE	–	–	69/68	80/80	72/71	368	73/72	80/80	76/76	372
			291A	12.4/16.5	34.4/39.7	112/118	125/125	112/117	402/408	116/121	125/125	116/121	406/412
			288A+291A	19.9/26.5	55.3/63.8	138/148	150/150	136/145	479/496	142/152	150/175	140/149	483/500
			294A	25.2/33.5	69.9/80.6	156/169	175/175	152/164	438/449	160/173	175/175	157/168	442/453
			288A+294A	32.7/43.5	90.7/104.7	182/199	200/200	176/192	549/577	186/203	200/225	181/196	553/581
		291A+294A	37.6/50.0	104.3/120.3	199/188	200/200	192/210	577/609	203/192	225/200	196/214	581/613	
		HIGH	NONE	–	–	81	100	86	407	84	100	90	411
			291A	12.4/16.5	34.4/39.7	124/130	125/150	125/131	441/447	127/134	150/150	130/136	445/451
			288A+291A	19.9/26.5	55.3/63.8	150/160	150/175	149/159	518/535	153/164	175/175	154/163	522/539
294A	25.2/33.5		69.9/80.6	168/181	175/200	166/178	477/488	172/185	175/200	170/183	481/492		
288A+294A	32.7/43.5		90.7/104.7	194/211	200/225	190/206	588/616	198/215	200/225	194/210	592/620		
291A+294A	37.6/50.0	104.3/120.3	211/201	225/225	206/224	616/648	215/205	225/225	210/228	620/652			
50TCQD14	460 – 3 – 60	STD	NONE	–	–	33	40	34	185	35	40	36	187
			292A	16.5	19.9	58	60	57	205	59	60	59	207
			289A+292A	26.5	31.9	73	80	71	249	74	80	73	251
			295A	33.5	40.3	83	90	80	225	85	90	82	227
			289A+295A	43.5	52.3	98	100	94	290	100	100	96	292
		292A+295A	50.0	60.2	93	100	103	305	95	100	105	307	
		MED	NONE	–	–	33	40	34	185	35	40	36	187
			292A	16.5	19.9	58	60	57	205	59	60	59	207
			289A+292A	26.5	31.9	73	80	71	249	74	80	73	251
			295A	33.5	40.3	83	90	80	225	85	90	82	227
			289A+295A	43.5	52.3	98	100	94	290	100	100	96	292
		292A+295A	50.0	60.2	93	100	103	305	95	100	105	307	
		HIGH	NONE	–	–	39	45	41	204	41	50	43	206
			292A	16.5	19.9	64	70	64	224	66	70	66	226
			289A+292A	26.5	31.9	79	80	78	268	81	90	80	270
295A	33.5		40.3	89	90	88	244	91	100	90	246		
289A+295A	43.5		52.3	104	110	102	309	106	110	104	311		
292A+295A	50.0	60.2	99	110	111	324	101	110	113	326			
50TCQD14	575 – 3 – 60	STD	NONE	–	–	28	30	29	138	32	35	33	142
			293A	16.5	15.9	48	50	47	154	52	60	52	158
			290A+293A	26.5	25.5	60	60	58	189	64	70	63	193
			296A	33.5	32.2	68	70	66	170	72	80	70	174
			290A+296A	43.5	41.8	80	80	77	222	84	90	82	226
		293A+296A	50.0	48.1	76	80	84	234	80	90	89	238	
		MED	NONE	–	–	28	30	29	138	32	35	33	142
			293A	16.5	15.9	48	50	47	154	52	60	52	158
			290A+293A	26.5	25.5	60	60	58	189	64	70	63	193
			296A	33.5	32.2	68	70	66	170	72	80	70	174
			290A+296A	43.5	41.8	80	80	77	222	84	90	82	226
		293A+296A	50.0	48.1	76	80	84	234	80	90	89	238	
		HIGH	NONE	–	–	33	40	34	150	36	40	39	154
			293A	16.5	15.9	52	60	53	166	56	60	57	170
			290A+293A	26.5	25.5	64	70	64	201	68	70	68	205
296A	33.5		32.2	73	80	71	182	77	80	76	186		
290A+296A	43.5		41.8	85	90	82	234	89	90	87	238		
293A+296A	50.0	48.1	81	90	90	246	84	90	94	250			

See Legend and Notes for Tables 67 – 108 on Page 113.

Legend and Notes for Tables 67–108

LEGEND

- C.O. – Convenience outlet
- DD – Electric Drive X13 Motor
- DISC – Disconnect
- FLA – Full load amps
- IFM – Indoor fan motor
- LRA – Locked rotor amps
- MCA – Minimum circuit amps
- MOCP – Maximum over current protection
- PE. – Power exhaust
- RLA – Rated load amps
- UNPWRD C.O. – Unpowered Convenience outlet

NOTES:

1. In compliance with NEC requirements for multimotor and combination load equipment (refer to NEC Articles 430 and 440), the overcurrent protective device for the unit shall be fuse or HACR breaker. Canadian units may be fuse or circuit breaker.
2. **Unbalanced 3-Phase Supply Voltage**
 Never operate a motor where a phase imbalance in supply voltage is greater than 2%. Use the following formula to determine the percentage of voltage imbalance.

$$\% \text{ Voltage Imbalance} = 100 \times \frac{\text{max voltage deviation from average voltage}}{\text{average voltage}}$$

Example: Supply voltage is 230-3-60



AB = 224V
 BC = 231V
 AC = 226V

$$\text{Average Voltage} = \frac{(224 + 231 + 226)}{3} = \frac{681}{3} = 227$$

Determine maximum deviation from average voltage.

(AB) 227 – 224 = 3V Maximum deviation is 4V.

(BC) 231 – 227 = 4V Determine percent of voltage imbalance.

$$\% \text{ Voltage Imbalance} = 100 \times \frac{4}{227} = 1.76\%$$

This amount of phase imbalance is satisfactory as it is below the maximum allowable 2%.

IMPORTANT: If the supply voltage phase imbalance is more than 2%, contact your local electric utility company immediately.

50TCQ

TYPICAL WIRING DIAGRAMS

HEAT PUMP CONTROL 208/230V, 460V, 575V
 10TON HP (2)COMPR T1
 8.5TON HP(2)COMPR T2

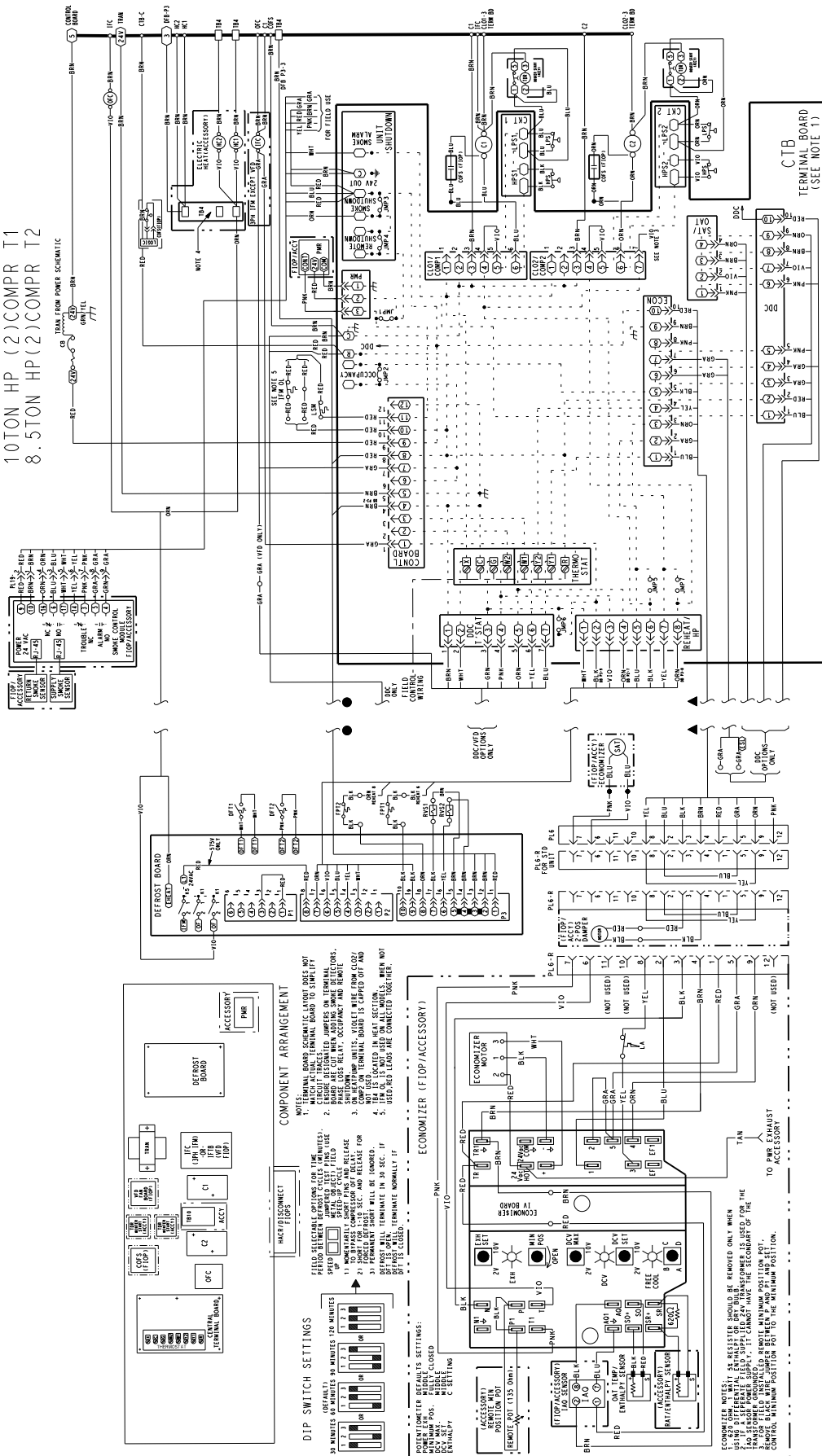

Fig. 25 - Typical Control Wiring Diagram: 2-Stage Unit with Electro-Mechanical Control Shown
NOTE: For details pertaining to a specific unit, see the Control Wiring Diagram label on the unit.

SEQUENCE OF OPERATION

Cooling, unit without economizer

Cooling (Single speed indoor fan motor) —

When thermostat calls for cooling, terminals G and Y1 are energized. The indoor fan contactor (IFC), reversing valve solenoid (RVS) and compressor contactor are energized and indoor fan motor, compressor, and outdoor fan starts. The outdoor fan motor runs continuously while unit is cooling.

Two-stage models: If Stage 1 cooling does not satisfy the space load, the space temperature will rise until thermostat calls for Stage 2 cooling (Y2 closes). Defrost Board activates Stage 2 Compressor. Reversing valve 2 switches to Cooling position. Compressor 2 contactor is energized; Compressor 2 starts and Circuit 2 operates in Cooling mode.

When Cooling Stage 2 is satisfied, thermostat Y2 opens. Compressor 2 contactor is de-energized; Compressor 2 stops. Reversing Valve 2 remains energized.

When Cooling Stage 1 is satisfied, thermostat Y1 opens. Compressor 1 contactor is de-energized; Compressor 1 stops. Outdoor fan relay is de-energized; outdoor fans stop. After the Fan Delay period, the Indoor fan contactor is de-energized; indoor fan stops (unless Continuous Fan operation has been selected). Reversing Valve 1 remains energized.

Reversing valve solenoids are energized in Cooling modes. Each solenoid will remain energized until the next Heating mode is initiated for this circuit.

Cooling (2-speed indoor fan motor) —

Per ASHRAE 90.1 standard section 6.4.3.10.b, during the first stage of cooling operation the VFD will adjust the fan motor to provide 2/3rd of the total cfm established for the unit. When a call for the second stage of cooling is required, the VFD will allow the total cfm for the unit established (100%).

Heating, unit without economizer

Upon a request for heating from the space thermostat, terminal W1 will be energized with 24V. The IFC, outdoor fan contactor (OFC), C1, and C2 will be energized. The indoor fan, outdoor fans, and compressor no. 1, and compressor no. 2 are energized and reversing valves are de-energized and switch position.

If the space temperature continues to fall while W1 is energized, W2 will be energized with 24V, and the heater contactor(s) (HC) will be energized, which will energize the electric heater(s).

When the space thermostat is satisfied, W2 will be de-energized first, and the electric heater(s) will be de-energized.

Upon a further rise in space temperature, W1 will be de-energized.

Two compressor models: When the thermostat calls for heating, terminal W1 is energized. Defrost Board de-energizes both reversing valve solenoids and reversing valves move to Heating position. The indoor fan contactor is energized; indoor fan motor starts. Outdoor fan relay is energized; both outdoor fan motors run. Compressor contactors C1 and C2 are energized; both refrigeration circuits operate in Heating mode.

If Stage 1 heating does not satisfy the space load, the space temperature will fall until thermostat calls for Stage 2 heating (W2 closes). Terminal W2 is energized. Defrost Board issues an output at EHEAT. Heater contactor 1 and heater contactor 2 (if installed) are energized; all electric heaters are energized.

When space heating load is partially satisfied, thermostat terminal W2 is de-energized; heater contactors are de-energized and all electric heat is terminated. Stage 1 heating continues.

When the space heating load is fully satisfied, thermostat terminal W1 is also de-energized.

Reversing valve solenoids remain de-energized until the next call for Cooling mode is initiated.

Cooling, unit with EconoMiSer IV

When free cooling is not available, the compressors will be controlled by the zone thermostat. When free cooling is available, the outdoor air damper is modulated by the EconoMiSer IV control to provide a 50 to 55°F (10° to 13°C) mixed air temperature into the zone. As the mixed air temperature fluctuates above 55 or below 50°F (13° to 10°C), the dampers will be modulated (open or close) to bring the mixed air temperature back within control.

If mechanical cooling is utilized with free cooling, the outdoor air damper will maintain its current position at the time the compressor is started. If the increase in cooling capacity causes the mixed air temperature to drop below 45°F (7°C), then the outdoor air damper position will be decreased to the minimum position. If the mixed air temperature continues to fall, the outdoor air damper will close. Control returns to normal once the mixed air temperature rises above 48°F (9°C).

If optional power exhaust is installed, as the outdoor air damper opens and closes, the power exhaust fans will be energized and de-energized.

If field-installed accessory CO₂ sensors are connected to the EconoMiSer IV control, a demand controlled ventilation strategy will begin to operate. As the CO₂ level in the zone increases above the CO₂ setpoint, the minimum position of the damper will be increased proportionally. As the CO₂ level decreases because of the increase in fresh air, the outdoor air damper will be proportionally closed.

SEQUENCE OF OPERATION (cont.)

For EconoMi\$er IV operation, there must be a thermostat call for the fan (G). If the unit is occupied and the fan is on, the damper will operate at minimum position. Otherwise, the damper will be closed.

When the EconoMi\$er IV control is in the occupied mode and a call for cooling exists (Y1 on the thermostat), the control will first check for indoor fan operation. If the fan is not on, then cooling will not be activated. If the fan is on, then the control will open the EconoMi\$er IV damper to the minimum position.

On the initial power to the EconoMi\$er IV control, it will take the damper up to 2¹/₂ minutes before it begins to position itself. Any change in damper position will take up to 30 seconds to initiate. Damper movement from full closed to full open (or vice versa) will take between 1¹/₂ and 2¹/₂ minutes.

If free cooling can be used as determined from the appropriate changeover command (switch, dry bulb, enthalpy curve, differential dry bulb, or differential enthalpy), then the control will modulate the dampers open to maintain the mixed air temperature setpoint at 50° to 55°F (10° to 13°C).

If there is a further demand for cooling (cooling second stage — Y2 is energized), then the control will bring on compressor stage 1 to maintain the mixed air temperature setpoint. The EconoMi\$er IV damper will be open at maximum position. EconoMi\$er IV operation is limited to a single compressor.

2-Speed Note: When operating in ventilation mode only, the indoor fan motor will automatically adjust to 2/3rd of the total cfm established.

Heating, unit with EconoMi\$er

When the room temperature calls for heat through terminal W1, the indoor (evaporator) fan contactor (IFC) and heater contactor no. 1 (HC1) are energized and the reversing valve(s) de-energize and switches position. On units equipped for 2 stages of heat, when additional heat is needed, heater contactor no. 2 is energized through W2. The economizer damper moves to the minimum position. When the thermostat is satisfied, the damper moves to the fully closed position.

Cooling, unit with EconoMi\$er2, PremierLink control and a thermostat

When free cooling is not available, the compressors will be controlled by the PremierLink control in response to the Y1 and Y2 inputs from the thermostat.

The PremierLink control will use the following information to determine if free cooling is available:

- Indoor fan has been on for at least 30 seconds.
- The SPT, SAT, and OAT inputs must have valid readings.
- OAT must be less than 75°F (24°C).

- OAT must be less than SPT.
- Enthalpy must be LOW (may be jumpered if an enthalpy sensor not available).
- Economizer position is NOT forced.

Pre-cooling occurs when there is no call from the thermostat except G. Pre-cooling is defined as the economizer modulates to provide 70°F (21°C) supply air.

When free cooling is available the PremierLink control will control the compressors, energize the reversing valve(s) and economizer to provide a supply air temperature determined to meet the Y1 and Y2 calls from the thermostat.

If optional power exhaust is installed, as the outdoor air damper opens and closes, the power exhaust fans will be energized and de-energized.

If field-installed accessory CO₂ sensors are connected to the PremierLink control, a PID controlled demand ventilation strategy will begin to operate. As the CO₂ level in the zone increases above the CO₂ setpoint, the minimum position of the damper will be increased proportionally. As the CO₂ level decreases because of the increase in fresh air, the outdoor air damper will be proportionally closed.

Heating, unit with EconoMi\$er2, PremierLink control and a thermostat

When the thermostat calls for heating, terminal W1 is energized. The PremierLink control will move the economizer damper to the minimum position if there is a call for G and closed if there is a call for W1 without G. In order to prevent thermostat from short cycling, the unit is locked into the heating mode for at least 10 minutes when W1 is energized. The reversing valve solenoid(s) de-energizes and switches position.

On units equipped for two stages of heat, when additional heat is needed, W2 is energized and the electric heat (if used) comes on. When the thermostat is satisfied and W1 is de-energized, the IFM stops.

Cooling, unit with EconoMi\$er2, PremierLink control and a room sensor

When free cooling is not available, the compressors will be controlled by the PremierLink controller using a PID Error reduction calculation.

The PremierLink controller will use the following information to determine if free cooling is available:

- Indoor fan has been on for at least 30 seconds.
- The SPT, SAT, and OAT inputs must have valid readings.
- OAT must be less than 75°F (24°C).
- OAT must be less than SPT.

SEQUENCE OF OPERATION (cont.)

- Enthalpy must be LOW (may be jumpered if an enthalpy sensor is not available).
- Economizer position is NOT forced.

When free cooling is available, the outdoor air damper is positioned through the use of a Proportional Integral (PID) control process to provide a calculated supply air temperature into the zone. The supply air will maintain the space temperature between the heating and cooling setpoints.

The PremierLink control will integrate the compressors stages with the economizer based on similar logic as the three routines listed in the previous section. The SASP will float up and down based on the error reduction calculations that compare space temperature and space setpoint. The reversing valves will be energized.

If an optional power exhaust is installed, as the outdoor air damper opens and closes, the power exhaust fans will be energized and de-energized.

If field- installed accessory CO₂ sensors are connected to the PremierLink control, a PID-controlled demand ventilation strategy will begin to operate. As the CO₂ level in the zone increases above the CO₂ setpoint, the minimum position of the damper will be increased proportionally. As the CO₂ level decreases because of the increase in fresh air, the outdoor air damper will be proportionally closed.

Heating, unit with EconoMiSer2, PremierLink control and a room sensor

Every 40 seconds the controller will calculate the required heat stages (maximum of 3) to maintain Supply Air Temperature (SAT) if the following qualifying conditions are met:

- Indoor fan has been on for at least 30 seconds.
- COOL mode is not active.
- OCCUPIED, TEMP.COMPENSATED START or HEAT mode is active.
- SAT reading is available.
- Fire shutdown mode is not active.

If all of the above conditions are met, the number of heat stages is calculated; otherwise the required number of heat stages will be set to 0.

If the PremierLink controller determines that heat stages are required, the economizer damper will be moved to minimum position if occupied and closed if unoccupied.

Defrost

When the temperature of the outdoor coil drops below 28°F (-2°C) as sensed by the defrost thermostat (DFT2) and the defrost timer is at the end of a timed period (adjustable at 30, 60, 90 or 120 minutes), reversing valve solenoids (RVS1 and RVS2) are energized and the OFC is de-energized. This switches the position of the reversing valves and shuts off the outdoor fan. The electric heaters (if installed) will be energized.

The unit continues to defrost until the coil temperature as measured by DFT2 reaches 65°F (18°C), or the duration of defrost cycle completes a 10-minute period.

During the Defrost mode, if circuit 1 defrosts first, RVS1 will oscillate between Heating and Cooling modes until the Defrost mode is complete.

At the end of the defrost cycle, the electric heaters (if installed) will be de-energized; the reversing valves switch and the outdoor fan motor will be energized. The unit will now operate in the Heating mode.

If the space thermostat is satisfied during a defrost cycle, the unit will continue in the Defrost mode until the time or temperature constraints are satisfied.

Automatic changeover

When the system selection switch is set at AUTO. position, unit automatically changes from heating operation to cooling operation when the temperature of the conditioned space rises to the cooling level setting. When the temperature of the conditioned space falls to the heating level setting, unit automatically changes from cooling to heating operation (with a 3°F deadband in between).

Continuous air circulation

Turn unit power on. Set system control at OFF position. Set fan switch at ON position. The indoor fan contactor is energized through the thermostat switch and the indoor fan runs continuously.

Emergency heat

When the switch is on (thermostat is set to the EM HT position), compressor circuit and outdoor thermostats are bypassed, and the second stage of thermostat energizes the indoor blower and the electric resistance heaters.

GUIDE SPECIFICATIONS - 50TCQ*04-14

Note about this specification:

Carrier created this specification in “Masterformat” as published by the Construction Specification Institute. Please feel free to copy this specification directly into your building specifications.

Rooftop Packaged Heat Pump

HVAC Guide Specifications

Size Range: 3 to 12.5 Nominal Tons



<u>Section</u>	<u>Description</u>
----------------	--------------------

23 06 80	Schedules for Decentralized HVAC Equipment
-----------------	---

23 06 80.13	Decentralized Unitary HVAC Equipment Schedule
-------------	---

23 06 80.13.A.	Rooftop unit schedule
----------------	-----------------------

1. Schedule is per the project specification requirements.

23 07 16	HVAC Equipment Insulation
-----------------	----------------------------------

23 07 16.13	Decentralized, Rooftop Units:
-------------	-------------------------------

23 07 16.13.A.	Evaporator fan compartment:
----------------	-----------------------------

1. Interior cabinet surfaces shall be insulated with a minimum 1/2-in. thick, minimum 1 1/2 lb density, flexible fiberglass insulation bonded with a phenolic binder, neoprene coated on the air side.
2. Insulation and adhesive shall meet NFPA 90A requirements for flame spread and smoke generation.

23 07 16.13.B.	Electric heat compartment:
----------------	----------------------------

1. Aluminum foil-faced fiberglass insulation shall be used.
2. Insulation and adhesive shall meet NFPA 90A requirements for flame spread and smoke generation.

23 09 13	Instrumentation and Control Devices for HVAC
-----------------	---

23 09 13.23	Sensors and Transmitters
-------------	--------------------------

23 09 13.23.A.	Thermostats
----------------	-------------

1. Thermostat must
 - a. have capability to energize 2 different stages of cooling, and 2 different stages of heating.
 - b. include capability for occupancy scheduling.

23 09 23	Direct-digital Control system for HVAC
-----------------	---

23 09 23.13	Decentralized, Rooftop Units:
-------------	-------------------------------

23 09 23.13.A.	PremierLink™ controller
----------------	-------------------------

1. Shall be ASHRAE compliant.
2. Shall accept 18-32VAC input power.
3. Shall have an operating temperature range from -40°F (-40°C) to 158°F (70°C), 10% - 95% RH (non-condensing).
4. Shall include an integrated economizer controller to support an economizer with 4 to 20 mA actuator input and no microprocessor controller.
5. Controller shall accept the following inputs: space temperature, setpoint adjustment, outdoor air temperature, indoor air quality, outdoor air quality, indoor relative humidity, compressor lock-out, fire shutdown, enthalpy, fan status, remote time clock/door switch.
6. Shall accept a CO₂ sensor in the conditioned space, and be Demand Control Ventilation (DCV) ready.
7. Shall provide the following outputs: Economizer, fan, cooling stage 1, cooling stage 2, heat stage 1, heat stage 2, heat stage 3/ exhaust/ reversing valve/ dehumidify/ occupied.
8. Unit shall provide surge protection for the controller through a circuit breaker.
9. Shall be Internet capable, and communicate at a Baud rate of 38.4K or faster
10. Shall have an LED display independently showing the status of activity on the communication bus, and processor operation.
11. Shall include an EIA-485 protocol communication port, an access port for connection of either a computer or a Carrier technician tool, an EIA-485 port for network communication to intelligent space sensors and displays, and a port to connect an optional LonWorks plug-in communications card.

12. Shall have built-in Carrier Comfort Network (CCN) protocol, and be compatible with other CCN devices, including ComfortLink and ComfortVIEW controllers.
13. Shall have built-in support for Carrier technician tool.
14. Software upgrades will be accomplished by local download. Software upgrades through chip replacements are not allowed.
15. Shall be shock resistant in all planes to 5G peak, 11ms during operation, and 100G peak, 11ms during storage.
16. Shall be vibration resistant in all planes to 1.5G @ 20-300 Hz.
17. Shall support a bus length of 4000 ft max, 60 devices per 1000 ft section, and 1 RS-485 repeater per 1000ft sections.

23 09 23.13.B. RTU Open Multi-protocol, direct digital controller:

1. Shall be ASHRAE 62 compliant.
2. Shall accept 18-30VAC, 50-60Hz, and consumer 15VA or less power.
3. Shall have an operating temperature range from -40°F (-40°C) to 130°F (54°C), 10% - 90% RH (non-condensing).
4. Shall include built-in protocol for BACNET (MS/TP and PTP modes), Modbus (RTU and ASCII), Johnson N2 and LonWorks. LonWorks Echelon processor required for all Lon applications shall be contained in separate communication board.
5. Shall allow access of up to 62 network variables (SNVT). Shall be compatible with all open controllers
6. Baud rate Controller shall be selectable using a dipswitch.
7. Shall have an LED display independently showing the status of serial communication, running, errors, power, all digital outputs, and all analog inputs.
8. Shall accept the following inputs: space temperature, setpoint adjustment, outdoor air temperature, indoor air quality, outdoor air quality, compressor lock-out, fire shutdown, enthalpy switch, and fan status/filter status/humidity/remote occupancy.
9. Shall provide the following outputs: economizer, fan, cooling stage 1, cooling stage 2, heat stage 1, heat stage 2, heat stage 3/ exhaust/ reversing valve.
10. Shall have built-in surge protection circuitry through solid state polyswitches. Polyswitches shall be used on incoming power and network connections. Polyswitches will return to normal when the "trip" condition clears.
11. Shall have a battery back-up capable of a minimum of 10,000 hours of data and time clock retention during power outages.
12. Shall have built-in support for Carrier technician tool.
13. Shall include an EIA-485 protocol communication port, an access port for connection of either a computer or a Carrier technician tool, an EIA-485 port for network communication to intelligent space sensors and displays, and a port to connect an optional LonWorks communications card.
14. Software upgrades will be accomplished by either local or remote download. No software upgrades through chip replacements are allowed.

23 09 33 Electric and Electronic Control System for HVAC

23 09 33.13 Decentralized, Rooftop Units:

23 09 33.13.A. General:

1. Shall be complete with self-contained low voltage control circuit protected by a resettable circuit breaker on the 24-v transformer side. Transformer shall have 75VA capability.
2. Shall utilize color-coded wiring.
3. Shall include a central control terminal board to conveniently and safely provide connection points for vital control functions such as: smoke detectors, phase monitor, economizer, thermostat, DDC control options, loss of charge, freeze switch, high pressure switches.
4. Unit shall include a minimum of one 8-pin screw terminal connection board for connection of control wiring.
5. Shall include integrated defrost system to prevent excessive frost accumulation during heating duty, and shall be controlled as follows:
 - a. Defrost shall be initiated on the basis of time and coil temperature.
 - b. A 30,60,90,120 minute timer shall activate the defrost cycle only if the coil temperature is low enough to indicate a heavy frost condition.
 - c. Defrost cycle shall terminate when defrost thermostat is satisfied and shall have a positive termination time of 10 minutes.
6. Defrost system shall also include:
 - a. Defrost Cycle Indicator LED.
 - b. Dip switch selectable defrost time between 30,60,90 and 120 minutes. Factory set at 30 minutes.

- c. Molded plug connection to insure proper connection.

23 09 33.23.B. Safeties:

1. Compressor overtemperature, overcurrent.
2. Loss of charge switch.
 - a. Units with 2 compressors shall have different sized connectors for the circuit 1 and circuit 2 low and high pressure switches. They shall physically prevent the cross-wiring of the safety switches between circuits 1 and 2.
 - b. Loss of charge switch shall use different color wire than the high pressure switch. The purpose is to assist the installer and service technician to correctly wire and or troubleshoot the rooftop unit.
3. High pressure switch.
 - a. Units with 2 compressors shall have different sized connectors for the circuit 1 and circuit 2 low and high pressure switches. They shall physically prevent the cross-wiring of the safety switches between circuits 1 and 2.
 - b. High pressure switch shall use different color wire than the low pressure switch. The purpose is to assist the installer and service technician to correctly wire and or troubleshoot the rooftop unit.
4. Freeze protection thermostat, evaporator coil.
5. Automatic reset, motor thermal overload protector.

23 09 93 Sequence of Operations for HVAC Controls

23 09 93.13 Decentralized, Rooftop Units:

23 09 93.13 INSERT SEQUENCE OF OPERATION

23 40 13 Panel Air Filters

23 40 13.13 Decentralized, Rooftop Units:

23 40 13.13.A. Standard filter section

1. Shall consist of factory-installed, low velocity, throwaway 2-in. thick fiberglass filters of commercially available sizes.
2. Unit shall use only one filter size. Multiple sizes are not acceptable.
3. Filters shall be accessible through an access panel with “no-tool” removal as described in the unit cabinet section of this specification (23 81 19.13.H).

23 81 19 Self-Contained Air Conditioners

23 81 19.13 Small-Capacity Self-Contained Air Conditioners (50TCQ*04-14)

23 81 19.13.A. General

1. Outdoor, rooftop mounted, electrically controlled, heating and cooling unit utilizing a(n) hermetic scroll compressor(s) for cooling duty and heat pump for heating duty.
2. Factory assembled, single piece heating and cooling rooftop unit. Contained within the unit enclosure shall be all factory wiring, piping, controls, and special features required prior to field startup.
3. Unit shall use Puron refrigerant.
4. Unit shall be installed in accordance with the manufacturer’s instructions.
5. Unit must be selected and installed in compliance with local, state, and federal codes.

23 81 19.13.B. Quality Assurance

1. Unit meets ASHRAE 90.1 minimum efficiency requirements.
2. Unit shall be rated in accordance with AHRI Standards 210/240 and 340/360.
3. Unit shall be designed to conform to ASHRAE 15.
4. Unit shall be UL-tested and certified in accordance with ANSI Z21.47 Standards and UL or ETL-listed and certified under Canadian standards as a total package for safety requirements.
5. Insulation and adhesive shall meet NFPA 90A requirements for flame spread and smoke generation.
6. Unit casing shall be capable of withstanding 500-hour salt spray exposure per ASTM B117 (scribed specimen).
7. Unit shall be designed in accordance with ISO 9001:2000, and shall be manufactured in a facility registered by ISO 9001:2000.
8. Roof curb shall be designed to conform to NRCA Standards.
9. Unit shall be subjected to a completely automated run test on the assembly line. The data for each unit will be stored at the factory, and must be available upon request.
10. Unit shall be designed in accordance with UL Standard 1995, including tested to withstand rain.
11. Unit shall be constructed to prevent intrusion of snow and tested to prevent snow intrusion into the control box up to 40 mph.

12. Unit shake tested to assurance level 1, ASTM D4169 to ensure shipping reliability.
 13. High Efficient Motors listed shall meet Section 313 of the Energy Independence and Security Act of 2007 (EISA 2007).
- 23 81 19.13.C. Delivery, Storage, and Handling
1. Unit shall be stored and handled per manufacturer's recommendations.
 2. Lifted by crane requires either shipping top panel or spreader bars.
 3. Unit shall only be stored or positioned in the upright position.
- 23 81 19.13.D. Project Conditions
1. As specified in the contract.
- 23 81 19.13.E. Operating Characteristics
1. Unit shall be capable of starting and running at 115°F (46°C) ambient outdoor temperature, meeting maximum load criteria of AHRI Standard 210/240 or 340/360 at ± 10% voltage.
 2. Compressor with standard controls shall be capable of operation from 25°F (-4°C), ambient outdoor temperatures. Accessory winter start kit is necessary if mechanically cooling at ambient temperatures below 25°F (-4°C).
 3. Unit shall be capable of simultaneous heating duty and defrost cycle operation when using accessory electric heaters.
 4. Unit shall discharge supply air vertically or horizontally as shown on contract drawings.
 5. Unit shall be factory configured for vertical supply & return configurations.
 6. Unit shall be field convertible from vertical to horizontal configuration
 7. Unit shall be capable of mixed operation: vertical supply with horizontal return or horizontal supply with vertical return.
- 23 81 19.13.F. Electrical Requirements
1. Main power supply voltage, phase, and frequency must match those required by the manufacturer.
- 23 81 19.13.G. Unit Cabinet
1. Unit cabinet shall be constructed of galvanized steel, and shall be bonderized and coated with a prepainted baked enamel finish on all externally exposed surfaces.
 2. Unit cabinet exterior paint shall be: film thickness, (dry) 0.003 inches minimum, gloss (per ASTM D523, 60°F): 60, Hardness: H-2H Pencil hardness.
 3. Evaporator fan compartment interior cabinet insulation shall conform to AHRI Standards 210/240 or 340/360 minimum exterior sweat criteria. Interior surfaces shall be insulated with a minimum 1/2-in. thick, 1 lb density, flexible fiberglass insulation, neoprene coated on the air side. Aluminum foil-faced fiberglass insulation shall be used in the heat compartment.
 4. Base of unit shall have a minimum of three locations for thru-the-base electrical connections (factory-installed or field-installed), standard.
 5. Base Rail
 - a. Unit shall have base rails on a minimum of 2 sides.
 - b. Holes shall be provided in the base rails for rigging shackles to facilitate maneuvering and overhead rigging.
 - c. Holes shall be provided in the base rail for moving the rooftop by fork truck.
 - d. Base rail shall be a minimum of 16 gauge thickness.
 6. Condensate pan and connections:
 - a. Shall be a sloped condensate drain pan made of a non-corrosive material.
 - b. Shall comply with ASHRAE Standard 62.
 - c. Shall use a 3/4-in. -14 NPT drain connection, possible either through the bottom or end of the drain pan. Connection shall be made per manufacturer's recommendations.
 7. Top panel:
 - a. Shall be a single piece top panel on 04 thru 09 sizes.
 8. Electrical Connections
 - a. All unit power wiring shall enter unit cabinet at a single, factory prepared, knockout location.
 - b. Thru-the-base capability.
 - (1.) Standard unit shall have a thru-the-base electrical location (s) using a raised, embossed portion of the unit basepan.
 - (2.) Optional, factory-approved, water-tight connection method must be used for thru-the-base electrical connections.
 - (3.) No basepan penetration, other than those authorized by the manufacturer, is permitted.

9. Component access panels (standard)
 - a. Cabinet panels shall be easily removable for servicing.
 - b. Unit shall have one factory-installed, tool-less, removable, filter access panel.
 - c. Panels covering control box, indoor fan, indoor fan motor, gas components (where applicable), and compressors shall have molded composite handles.
 - d. Handles shall be UV modified, composite, permanently attached, and recessed into the panel.
 - e. Screws on the vertical portion of all removable access panel shall engage into heat resistant, molded composite collars.
 - f. Collars shall be removable and easily replaceable using manufacturer recommended parts.

23 81 19.13.H. Coils

1. Standard Aluminum/Copper Coils: on all models.
 - a. Standard evaporator and condenser coils shall have aluminum lanced plate fins mechanically bonded to seamless internally grooved copper tubes with all joints brazed.
 - b. Evaporator coils shall be leak tested to 150 psig, pressure tested to 450 psig, and qualified to UL 1995 burst test at 1775 psig.
 - c. Condenser coils shall be leak tested to 150 psig, pressure tested to 650 psig, and qualified to UL 1995 burst test at 1980 psig.
2. Optional Pre-coated aluminum fin condenser coils: on all models.
 - a. Shall have a durable epoxy-phenolic coating to provide protection in mildly corrosive coastal environments.
 - b. Coating shall be applied to the aluminum fin stock prior to the fin stamping process to create an inert barrier between the aluminum fin and copper tube.
 - c. Epoxy-phenolic barrier shall minimize galvanic action between dissimilar metals.
3. Optional Copper-fin evaporator and condenser coils: on all models.
 - a. Shall be constructed of copper fins mechanically bonded to copper tubes and copper tube sheets.
 - b. Galvanized steel tube sheets shall not be acceptable.
 - c. A polymer strip shall prevent coil assembly from contacting the sheet metal coil pan to minimize potential for galvanic corrosion between coil and pan.
4. Optional E-coated aluminum-fin evaporator and condenser coils: on all models.
 - a. Shall have a flexible epoxy polymer coating uniformly applied to all coil surface areas without material bridging between fins.
 - b. Coating process shall ensure complete coil encapsulation of tubes, fins and headers.
 - c. Color shall be high gloss black with gloss per ASTM D523-89.
 - d. Uniform dry film thickness from 0.8 to 1.2 mil on all surface areas including fin edges.
 - e. Superior hardness characteristics of 2H per ASTM D3363-92A and cross-hatch adhesion of 4B-5B per ASTM D3359-93.
 - f. Impact resistance shall be up to 160 in.-lb (ASTM D2794-93).
 - g. Humidity and water immersion resistance shall be up to minimum 1000 and 250 hours respectively (ASTM D2247-92 and ASTM D870-92).
 - h. Corrosion durability shall be confirmed through testing to be no less than 1000 hours salt spray per ASTM B117-90.

23 81 19.13.I. Refrigerant Components

1. Refrigerant circuit shall include the following control, safety, and maintenance features:
 - a. Fixed orifice metering system shall prevent mal-distribution of two-phase refrigerant by including multiple fixed orifice devices in each refrigeration circuit. Each orifice is to be optimized to the coil circuit it serves.
 - b. Refrigerant filter drier.
 - c. Service gauge connections on suction and discharge lines.
 - d. Pressure gauge access through a specially designed access port in the top panel of the unit.
 - e. Suction line accumulator to provide protection in all operating modes from cooling, heating and reverse cycle switching.
2. There shall be gauge line access port in the top of the rooftop, covered by a black, removable plug.
 - a. The plug shall be easy to remove and replace.
 - b. When the plug is removed, the gauge access port shall enable maintenance personnel to route their pressure gauge lines.

- c. This gauge access port shall facilitate correct and accurate condenser pressure readings by enabling the reading with the compressor access panel on.
- d. The plug shall be made of a leak proof, UV-resistant, composite material.

3. Compressors

- a. Unit shall use one fully hermetic, scroll compressor for each independent refrigeration circuit.
- b. Models shall be available with single compressor designs on 04-07 models, plus additional 2 compressor (stage) models from 08-14 sizes.
- c. Compressor motors shall be cooled by refrigerant gas passing through motor windings.
- d. Compressors shall be internally protected from high discharge temperature conditions.
- e. Compressors shall be protected from an overtemperature and over-ampereage conditions by an internal, motor overload device.
- f. Compressor shall be factory mounted on rubber grommets.
- g. Compressor motors shall have internal line break thermal, current overload and high pressure differential protection.
- h. Crankcase heaters shall be utilized on all models (except 04 size) to protect compressor with specific refrigerant charge.

23 81 19.13.J. Filter Section

- 1. Filters access is specified in the unit cabinet section of this specification.
- 2. Filters shall be held in place by a pivoting filter tray, facilitating easy removal and installation.
- 3. Shall consist of factory-installed, low velocity, throw-away 2-in. thick fiberglass filters.
- 4. Filters shall be standard, commercially available sizes.
- 5. Only one size filter per unit is allowed.

23 81 19.13.K. Evaporator Fan and Motor

- 1. Evaporator fan motor:
 - a. Shall have permanently lubricated bearings.
 - b. Shall have inherent automatic-reset thermal overload protection or circuit breaker.
 - c. Shall have a maximum continuous bhp rating for continuous duty operation; no safety factors above that rating shall be required.
- 2. Electric Drive (Direct Drive) X13 – 5 Speed/Torque Evaporator Fan:
 - a. Multi speed motor with easy quick adjustment settings.
 - b. Blower fan shall be double inlet type with forward curved blades.
 - c. Shall be constructed from steel with a corrosion resistant finish and dynamically balanced.
 - d. Standard on all 04-06 models.
- 3. Belt-driven Evaporator Fan:
 - a. Belt drive shall include an adjustable pitch motor pulley.
 - b. Shall use sealed, permanently lubricated ball-bearing type.
 - c. Blower fan shall be double inlet type with forward curved blades.
 - d. Shall be constructed from steel with a corrosion resistant finish and dynamically balanced.
 - e. Standard on all 07-14 size models. Optional on all 04-06 3-phase models.

23 81 19.13.L. Condenser Fans and Motors

- 1. Condenser fan motors:
 - a. Shall be a totally enclosed motor.
 - b. Shall use permanently lubricated bearings.
 - c. Shall have inherent thermal overload protection with an automatic reset feature.
 - d. Shall use a shaft down design on 04 to 14 models.
- 2. Condenser Fans:
 - a. Shall be a direct driven propeller type fan.
 - b. Shall have aluminum blades riveted to corrosion resistant steel spiders and shall be dynamically balanced.

23 81 19.13.M. Special Features, Options and Accessories

- 1. Staged Air Volume System (SAV) for 2-stage cooling models only.
 - a. Evaporator fan motor:
 - (1.) Shall have permanently lubricated bearings.
 - (2.) Shall have a maximum continuous bhp rating for continuous duty operation; no safety factors above that rating.

- (3.) Shall be Variable Frequency duty and 2-speed control.
 - (4.) Shall contain motor shaft grounding ring to prevent electrical bearing fluting damage by safely diverting harmful shaft voltages and bearing currents to ground.
2. Variable Frequency Drive (VFD). Only available on 2-speed indoor fan motor option (SAV):
 - a. Shall be installed inside the unit cabinet, mounted, wired and tested.
 - b. Shall contain Electromagnetic Interference (EMI) frequency protection.
 - c. Insulated Gate Bi-Polar Transistors (IGBT) used to produce the output pulse width modulated (PWM) waveform, allowing for quiet motor operation.
 - d. Self diagnostics with fault and power code LED indicator. Field accessory Display Kit available for further diagnostics and special setup applications.
 - e. RS485 capability standard.
 - f. Electronic thermal overload protection.
 - g. 5% swinging chokes for harmonic reduction and improved power factor.
 - h. All printed circuit boards shall be conformal coated.
 3. Integrated EconoMiSer IV, EconoMiSer2, and EconoMiSer X **standard leak rate models**. (Factory installed on 3 phase models only. Field installed on all 3 and 1 phase models)
 - a. Integrated, gear driven opposing modulating blade design type capable of simultaneous economizer and compressor operation.
 - b. Independent modules for vertical or horizontal return configuration shall be available. Vertical return modules shall be available as a factory installed option.
 - c. Damper blades shall be galvanized steel with composite gears. Plastic or composite blades on intake or return shall not be acceptable.
 - d. Shall include all hardware and controls to provide free cooling with outdoor air when temperature and/or humidity are below setpoints.
 - e. Shall be equipped with gear driven dampers for both the outdoor ventilation air and the return air for positive air stream control.
 - f. Standard leak rate shall be equipped with dampers not to exceed 2% leakage at 1 in. wg pressure differential.
 - g. Economizer controller on EconoMiSer IV models shall be Honeywell W7212 that provides:
 - (1.) Combined minimum and DCV maximum damper position potentiometers with compressor staging relay.
 - (2.) Functions with solid state analog enthalpy or dry bulb changeover control sensing.
 - (3.) Contain LED indicates for:
 - when free cooling is available, when module is in DCV mode, when exhaust fan contact is closed.
 - h. Economizer controller on EconoMiSer X models shall be the Honeywell W7220 that provides:
 - (1.) 2-line LCD interface screen for setup, configuration and troubleshooting.
 - (2.) On-board Fault Detection and Diagnostics (FDD) that senses and alerts when the economizer is not operating properly, per California Title 24.
 - (3.) Sensor failure loss of communication identification
 - (4.) Automatic sensor detection
 - (5.) Capabilities for use with multiple-speed indoor fan systems
 - (6.) Utilize digital sensors: Dry bulb and Enthalpy
 - i. Economizer controller on EconoMiSer 2 models with PremierLink shall be 4-20mA design and controlled by the PremierLink controller. PremierLink does not comply with California Title 24 Fault Detection & Diagnostic (FDD) requirements.
 - j. Economizer controller on EconoMiSer 2 models with RTU Open models shall be a 4-20mA design controlled directly by the RTU Open controller. RTU Open meets California Title 24 Fault Detection & Diagnostic (FDD) requirements.
 - k. Shall be capable of introducing up to 100% outdoor air.
 - l. Shall be equipped with a barometric relief damper capable of relieving up to 100% return air and contain seals that meet ASHRAE 90.1 requirements.
 - m. Shall be designed to close damper(s) during loss-of-power situations with spring return built into motor.
 - n. Dry bulb outdoor air temperature sensor shall be provided as standard. Enthalpy sensor is also available on factory installed only. Outdoor air sensor setpoint shall be adjustable and shall range from 40 to 100F /4 to 38C. Additional sensor options shall be available as accessories.

- o. The economizer controller shall also provide control of an accessory power exhaust unit function. Factory set at 100%, with a range of 0% to 100%.
 - p. The economizer shall maintain minimum airflow into the building during occupied period and provide design ventilation rate for full occupancy.
 - q. Dampers shall be completely closed when the unit is in the unoccupied mode.
 - r. Economizer controller shall accept a 2-10 Vdc CO₂ sensor input for IAQ/DCV control. In this mode, dampers shall modulate the outdoor air damper to provide ventilation based on the sensor input.
 - s. Compressor lockout temperature on W7220 is adjustable from -45°F to 80°F, set at a factory default of 32°F. Others shall open at 35°F (2°C) and closes at 50°F (10°C).
 - t. Actuator shall be direct coupled to economizer gear. No linkage arms or control rods shall be acceptable.
 - u. Economizer controller shall provide indications when in free cooling mode, in the DCV mode, or the exhaust fan contact is closed.
4. Integrated EconoMi\$er2, and EconoMi\$er X **Ultra Low Leak rate models**. (Factory installed on 3 phase models only. Field installed on all 3 and 1 phase models)
- a. Integrated, gear driven opposing modulating blade design type capable of simultaneous economizer and compressor operation.
 - b. Independent modules for vertical or horizontal return configuration shall be available. Vertical return modules shall be available as a factory installed option.
 - c. Damper blades shall be galvanized steel with composite gears. Plastic or composite blades on intake or return shall not be acceptable.
 - d. Shall include all hardware and controls to provide free cooling with outdoor air when temperature and/or humidity are below setpoints.
 - e. Shall be equipped with gear driven dampers for both the outdoor ventilation air and the return air for positive air stream control
 - f. Ultra Low Leak design meets California Title 24 section 140.4 and ASHRAE90.1 requirements for 4 cfm per sq.ft. on the outside air dampers and 10 cfm per sq. ft. on the return dampers.
 - g. Economizer controller on EconoMi\$er X models shall be the Honeywell W7220 that provides:
 - (1.) 2-line LCD interface screen for setup, configuration and troubleshooting
 - (2.) On-board Fault Detection and Diagnostics (FDD) that senses and alerts when the economizer is not operating properly, per California Title 24.
 - (3.) Sensor failure loss of communication identification
 - (4.) Automatic sensor detection
 - (5.) Capabilities for use with multiple-speed indoor fan systems
 - (6.) Utilize digital sensors: Dry bulb and Enthalpy
 - h. Economizer controller on EconoMi\$er 2 models with RTU Open models shall be a 4-20mA design controlled directly by the RTU Open controller. RTU Open meets California Title 24 Fault Detection & Diagnostic (FDD) requirements.
 - i. Shall be capable of introducing up to 100% outdoor air.
 - j. Shall be equipped with a barometric relief damper capable of relieving up to 100% return air and contain seals that meet ASHRAE 90.1 requirements.
 - k. Shall be designed to close damper(s) during loss-of-power situations with spring return built into motor.
 - l. Dry bulb outdoor air temperature sensor shall be provided as standard. Enthalpy sensor is also available on factory installed only. Outdoor air sensor setpoint shall be adjustable and shall range from 40 to 100° F / 4 to 38° C. Additional sensor options shall be available as accessories.
 - m. The economizer controller shall also provide control of an accessory power exhaust unit function. Factory set at 100%, with a range of 0% to 100%.
 - n. The economizer shall maintain minimum airflow into the building during occupied period and provide design ventilation rate for full occupancy.
 - o. Dampers shall be completely closed when the unit is in the unoccupied mode.
 - p. Economizer controller shall accept a 2-10 Vdc CO₂ sensor input for IAQ/DCV control. In this mode, dampers shall modulate the outdoor air damper to provide ventilation based on the sensor input.
 - q. Compressor lockout temperature on W7220 is adjustable from -45° F to 80° F, set at a factory default of 32° F. Others shall open at 35°F (2°C) and closes at 50°F (10°C).
 - r. Actuator shall be direct coupled to economizer gear. No linkage arms or control rods shall be acceptable.
 - s. Economizer controller shall provide indications when in free cooling mode, in the DCV mode, or the exhaust fan contact is closed.

5. Two-Position Damper (Factory installed on 3 Phase Models Only. Field installed on all 3 and 1 Phase Models)
 - a. Damper shall be a Two-Position Damper. Damper travel shall be from the full closed position to the field adjustable %-open setpoint.
 - b. Damper shall include adjustable damper travel from 25% to 100% (full open).
 - c. Damper shall include single or dual blade, gear driven dampers and actuator motor.
 - d. Actuator shall be direct coupled to damper gear. No linkage arms or control rods shall be acceptable.
 - e. Damper will admit up to 100% outdoor air for applicable rooftop units.
 - f. Damper shall close upon indoor (evaporator) fan shutoff and/or loss of power.
 - g. The damper actuator shall plug into the rooftop unit's wiring harness plug. No hard wiring shall be required.
 - h. Outside air hood shall include aluminum water entrainment filter
 - i. Not available with Staged Air Volume (SAV) models.
6. Head Pressure Control Package
 - a. Controller shall control coil head pressure by condenser fan speed modulation or condenser fan cycling and wind baffles.
 - b. Shall consist of solid state control and condenser coil temperature sensor to maintain condensing temperature between 90°F (32°C) and 110°F (43°C) at outdoor ambient temperatures down to -20°F (-29°C).
7. Condenser Coil Hail Guard Assembly
 - a. Shall protect against damage from hail.
 - b. Shall be louvered design.
8. Unit Mounted, Non-Fused Disconnect Switch:
 - a. Switch shall be factory-installed, internally mounted.
 - b. National Electric Code (NEC) and UL approved non-fused switch shall provide unit power shutoff.
 - c. Shall be accessible from outside the unit
 - d. Shall provide local shutdown and lockout capability.
9. Convenience Outlet:
 - a. Powered convenience outlet. (Not available on single phase models)
 - (1.) Outlet shall be powered from main line power to the rooftop unit.
 - (2.) Outlet shall be powered from line side or load side of disconnect by installing contractor, as required by code. If outlet is powered from load side of disconnect, unit electrical ratings shall be UL certified and rated for additional outlet amperage.
 - (3.) Outlet shall be factory-installed and internally mounted with easily accessible 115-v female receptacle.
 - (4.) Outlet shall include 15 amp GFI receptacles with independent fuse protection.
 - (5.) Voltage required to operate convenience outlet shall be provided by a factory-installed step down transformer.
 - (6.) Outlet shall be accessible from outside the unit.
 - b. Non-Powered convenience outlet.
 - (1.) Outlet shall be powered from a separate 115-120v power source.
 - (2.) A transformer shall not be included.
 - (3.) Outlet shall be factory-installed and internally mounted with easily accessible 115-v female receptacle.
 - (4.) Outlet shall include 15 amp GFI receptacles.
 - (5.) Outlet shall be accessible from outside the unit.
10. Thru-the-Base Connectors:
 - a. Kits shall provide connectors to permit electrical connections to be brought to the unit through the unit basepan.
 - b. Minimum of three connection locations per unit.
11. Propeller Power Exhaust:
 - a. Power exhaust shall be used in conjunction with an integrated economizer.
 - b. Independent modules for vertical or horizontal return configurations shall be available.
 - c. Horizontal power exhaust shall be mounted in return ductwork.
 - d. Power exhaust shall be controlled by economizer controller operation. Exhaust fans shall be energized when dampers open past the 0-100% adjustable setpoint on the economizer control.
12. Roof Curbs (Vertical):

- a. Full perimeter roof curb with exhaust capability providing separate air streams for energy recovery from the exhaust air without supply air contamination.
 - b. Formed galvanized steel with wood nailer strip and shall be capable of supporting entire unit weight.
 - c. Permits installation and securing of ductwork to curb prior to mounting unit on the curb.
13. High Static Indoor Fan Motor(s) and Drive(s) (04-14):
- a. High static motor(s) and drive(s) shall be factory-installed to provide additional performance range.
14. Thru-the-Bottom Utility Connectors:
- a. Kit shall provide connectors to permit gas and electrical connections to be brought to the unit through the basepan.
15. Outdoor Air Enthalpy Sensor:
- a. The outdoor air enthalpy sensor shall be used to provide single enthalpy control. When used in conjunction with a return air enthalpy sensor, the unit will provide differential enthalpy control. The sensor allows the unit to determine if outside air is suitable for free cooling.
16. Return Air Enthalpy Sensor:
- a. The return air enthalpy sensor shall be used in conjunction with an outdoor air enthalpy sensor to provide differential enthalpy control.
17. Indoor Air Quality (CO₂) Sensor:
- a. Shall be able to provide demand ventilation indoor air quality (IAQ) control.
 - b. The IAQ sensor shall be available in duct mount, wall mount, or wall mount with LED display. The set-point shall have adjustment capability.
18. Smoke detectors (Factory-Installed Only):
- a. Shall be a Four-Wire Controller and Detector.
 - b. Shall be environmental compensated with differential sensing for reliable, stable, and drift-free sensitivity.
 - c. Shall use magnet activated test/reset sensor switches.
 - d. Shall have tool-less connection terminal access.
 - e. Shall have a recessed momentary switch for testing and resetting the detector.
 - f. Controller shall include:
 - (1.) One set of normally open alarm initiation contacts for connection to an initiating device circuit on a fire alarm control panel.
 - (2.) Two Form-C auxiliary alarm relays for interface with rooftop unit or other equipment.
 - (3.) One Form-C supervision (trouble) relay to control the operation of the Trouble LED on a remote test/reset station.
 - (4.) Capable of direct connection to two individual detector modules.
 - (5.) Can be wired to up to 14 other duct smoke detectors for multiple fan shutdown applications.
19. Time Guard
- a. Shall prevent compressor short cycling by providing a 5-minute delay (± 2 minutes) before restarting a compressor after shutdown for any reason.
 - b. One device shall be required per compressor.
20. Electric Heat:
- a. Heating Section
 - (1.) Heater element open coil resistance wire, nickel-chrome alloy, 0.29 inches inside diameter, strung through ceramic insulators mounted on metal frame. Coil ends are staked and welded to terminal screw slots.
 - (2.) Heater assemblies are provided with integral fusing for protection of internal heater circuits not exceeding 48 amps each. Auto reset thermo limit controls, magnetic heater contactors (24V coil) and terminal block all mounted in electric heater control box (minimum 18 ga galvanized steel) attached to end of heater assembly.
21. California OSHPD Seismic Certification Label
- a. Units meet the seismic requirements of the International Code Council Evaluation Service (ICC-ES) document AC156 (Acceptance Criteria for Seismic Qualification by Shake-Table Testing of Nonstructural Components and Systems) and per International Building Code (IBC 2009) at an SDS (g) value of 2.00 z/h=1.0, Ip=1.5 and certified by independent structural engineers.
 - b. Units shall include a certification label that meets the CA OSHPD Special Seismic Certification pre-approval labeling requirements on the external chassis of the unit.
22. Hinged Access Panels
- a. Shall provide easy access through integrated quarter turn latches.

- b. Shall be on major panels of: filters, control box, fan motor and compressor.
- 23. Display Kit for Variable Frequency Drive
 - a. Kit allows the ability to access the VFD controller programs to provide special setup capabilities and diagnostics.
 - b. Kit contains display module and communication cable.
 - c. Display Kit can be permanently installed in the unit or used on any SAV system VFD controller as needed.
- 24. Manual Damper
 - a. Manual Damper package shall consist of damper, air inlet screen, and rain hood which can be preset to admit up to 25 or 50% outdoor air for year-round ventilation. Not available with Staged Air Volume (SAV) models.

