

Submittal

4.0 Ton Variable Speed Convertible Air Handler A4AH6V48A1C30B

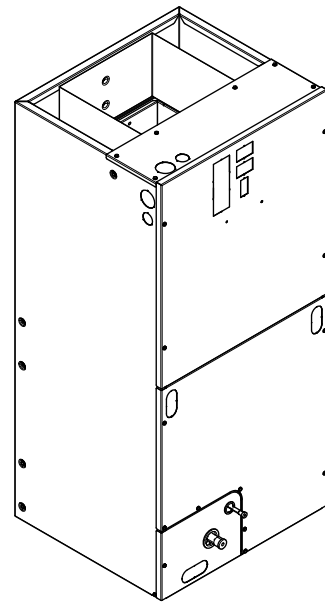

March 2022

A4AH6V48A1C-SUB-1B-EN

Outline Drawing

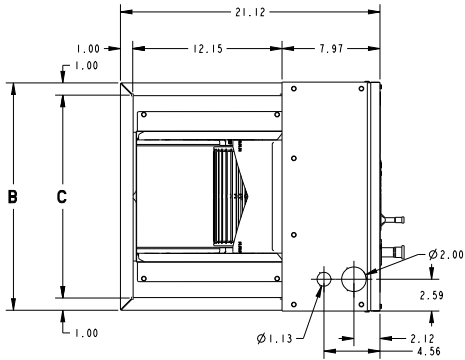

MINIMUM UNIT CLEARANCE TABLE	
	SERVICE CLEARANCE (RECOMMENDED)
SIDES	2"
FRONT	21"
BACK	0"
INLET DUCT	1"
OUTLET DUCT	N/A

NOTE: THIS UNIT IS APPROVED FOR INSTALLATION CLEARANCES TO COMBUSTIBLE MATERIAL AS STATED ON THE UNIT RATING NAMEPLATE

ALL DIMENSIONS ARE REFERENCE DIMENSIONS

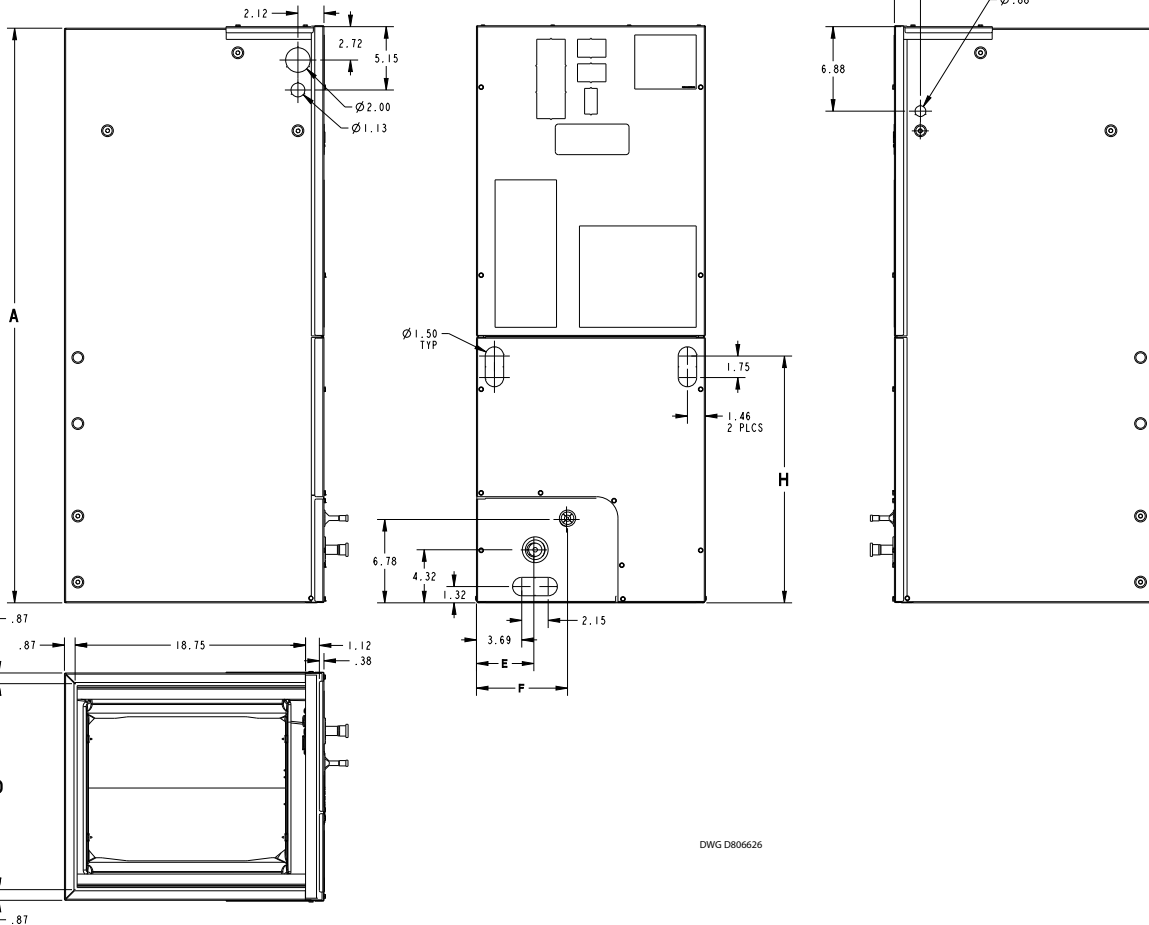

DWG D806626

PRODUCT DIMENSIONS									
Air Handler Model	A	B	C	D	E	F	H	Flow Control	Gas Line Braze
A4AH6V48A1C	57.40	23.50	21.50	21.75	4.68	9.66	27.19	TXV	7/8
All dimensions are in inches									

Product Specifications

MODEL	A4AH6V48A1C30B
RATED VOLTS/PH/HZ	208-230/1/60
RATINGS^(a)	See O.D. Specifications
INDOOR COIL — Type	Plate Fin
Rows — F.P.I.	3 - 16
Face Area (sq. ft.)	7.9
Tube Size (in.)	3/8
Refrigerant Control	TXV
Drain Conn. Size (in.) ^(b)	3/4 NPT
DUCT CONNECTIONS	See Outline Drawing
INDOOR FAN — Type	Centrifugal
Diameter-Width (In.)	11 X 11
No. Used	1
Drive - No. Speeds	Direct - 16
CFM vs. in. w.g.	See Fan Performance Table
No. Motors — H.P.	1 - 3/4
Motor Speed R.P.M.	Variable
Volts/Ph/Hz	208-230/1/60

F.L. Amps	6.8
FILTER	
Filter Furnished? ^(c)	No
REFRIGERANT	R-410A
Ref. Line Connections	Brazed
Coupling or Conn. Size — in. Gas	7/8
Coupling or Conn. Size — in. Liq.	3/8
DIMENSIONS	H x W x D
Crated (In.)	57-1/8 x 27-1/2 x 25-1/2
Uncrated	55-3/4 x 23-1/2 x 21-1/8
WEIGHT	
Shipping (Lbs.) / Net (Lbs.)	185/174

^(a) These Air Handlers are A.H.R.I certified with various Split System Air Conditioners and Heat Pumps (AHRI STANDARD 210/240). Refer to the Split System Outdoor Unit Product Data Guides for performance data.

^(b) 3/4" Male Plastic Pipe (Ref: ASTM 1785-76)

^(c) Remote filter required.

Minimum Airflow CFM

A4AH6V48A1C30B		
Heater	Minimum Heater Airflow CFM	
	With Heat Pump	Without Heat Pump
BAYHTR1504BRK, BAYHTR1504LUG BAYHTR1505BRK, BAYHTR1505LUG	1200	975
BAYHTR1508BRK, BAYHTR1508LUG	1350	975
BAYHTR1510BRK, BAYHTR1510LUG	1350	975
BAYHTR1517BRK	1365	975
BAYHTR3510LUG	1300	975
BAYHTR3517LUG	1365	1120
BAYHTR1523BRK	1365	1300
BAYHTR1525BRK	1810	1505

A4AH6V48A1C30B Airflow Performance with Auxiliary Heat				
Airflow Settings	Dip Switch Settings		Nominal Airflow	See following tables for heater application: - Pressure Drop for Electrical Heaters - Minimum Heating Airflow Matrix (on unit nameplates)
	Switch 7	Switch 8		
Low	ON	ON	1000	
Med-Lo	OFF	ON	1130	
Med-Hi	ON	OFF	1354	
High	OFF	OFF	1596	

Heater Pressure Drop Table

Airflow CFM	Number of Racks				Heater Racks	
	1	2	3	4	Heater Model	No. of Racks
	Air Pressure Drop — Inches W.G.					
1800	0.02	0.04	0.06	0.14	BAYHTR1504	1
1700	0.02	0.04	0.06	0.14	BAYHTR1505	1
1600	0.02	0.04	0.06	0.13	BAYHTR1508	2
1500	0.02	0.04	0.06	0.12	BAYHTR1510	2
1400	0.02	0.04	0.06	0.12	BAYHTR1517	3
1300	0.02	0.04	0.05	0.11	BAYHTR3510	3
1200	0.01	0.04	0.05	0.10	BAYHTR3517	3
1100	0.01	0.03	0.05	0.09	BAYHTR3515	3
1000	0.01	0.03	0.04	0.09	BAYHTR1523	4
900	0.01	0.03	0.04	0.08	BAYHTR1525	4
800	0.01	0.03				
700	0.01	0.02				
600	0.01	0.02				

Subcooling Adjustment for A4AH6V48A1 and A4AH6V60B1

Sub-Cooling Charge Specification For AHRI Rated Performance		
OD Equipment	Up Flow / Horizontal	Down Flow
AC UNIT	OD Name Plate	OD Name Plate
HP UNIT ≤ 3.5 Tons	OD Name Plate	OD Name Plate + 4 Degrees
HP UNIT = 4 and 5 Tons	OD Name Plate	OD Name Plate

Performance and Electrical Data

1. See Product Data or Air Handler nameplate for approved combinations of Air Handlers and Heaters.
2. Heater model numbers may have additional suffix digits.

Table 1. Air Flow Performance

A4AH6V48A1C30B COOLING AIRFLOW PERFORMANCE, WET COIL, NO FILTER, NO HEATER												
OUTDOOR UNIT SIZE (TONS)	SPEED SETTING	AIRFLOW SETTING	DIP SWITCH SETTING				AIRFLOW POWER	EXTERNAL STATIC PRESSURE				
			SW1	SW2	SW3	SW4		0.1	0.3	0.5	0.7	0.9
3	LOW	324 CFM/ton	ON	ON	OFF	ON	CFM Watts	991 89	985 133	974 186	984 237	994 303
	NORMAL	368 CFM/ton	ON	ON	OFF	OFF	CFM Watts	1120 118	1119 167	1110 224	1116 279	1122 333
	HIGH	423 CFM/ton	ON	ON	ON	OFF	CFM Watts	1282 162	1286 219	1281 280	1280 343	1282 402
3.5	LOW	314 CFM/ton	OFF	ON	OFF	ON	CFM Watts	1116 117	1114 165	1105 222	1111 277	1117 331
	NORMAL	357 CFM/ton	OFF	ON	OFF	OFF	CFM Watts	1263 156	1266 212	1261 273	1261 334	1263 392
	HIGH	411 CFM/ton	OFF	ON	ON	OFF	CFM Watts	1449 218	1458 287	1456 352	1449 421	1447 496
4	LOW	298 CFM/ton	ON	OFF	OFF	ON	CFM Watts	1207 140	1208 193	1201 252	1203 311	1207 366
	NORMAL	339 CFM/ton	ON	OFF	OFF	OFF	CFM Watts	1368 190	1374 252	1370 315	1367 381	1367 448
	HIGH	389 CFM/ton	ON	OFF	ON	OFF	CFM Watts	1564 264	1577 343	1577 411	1567 484	1561 570
5	LOW	305 CFM/ton	OFF	OFF	OFF	ON	CFM Watts	1534 251	1545 328	1545 394	1536 467	1531 550
	NORMAL (a)	347 CFM/ton	OFF	OFF	OFF	OFF	CFM Watts	1740 344	1758 444	1762 518	1745 594	1734 684
	HIGH (b)	399 CFM/ton	OFF	OFF	ON	OFF	CFM Watts	1995 484	2022 629	2030 717	2005 783	1987 828

(a) Factory Default Setting

(b) Airflow must not exceed 1800 cfm in horizontal right, horizontal left, and downflow applications due to condensate blowoff. The 5 ton high tap shall not be used in these applications.

Table 2. Air Flow Performance

A4AH6V48A1C30B HEATING AIRFLOW PERFORMANCE, NO FILTER, NO HEATER												
OUTDOOR UNIT SIZE (TONS)	SPEED SETTING	AIRFLOW SETTING	DIP SWITCH SETTING				AIRFLOW POWER	EXTERNAL STATIC PRESSURE				
			SW1	SW2	SW3	SW4		0.1	0.3	0.5	0.7	0.9
3	LOW	360 CFM/ton	ON	ON	OFF	ON	CFM Watts	1097 112	1094 160	1086 216	1092 271	1099 326
	NORMAL	400 CFM/ton	ON	ON	OFF	OFF	CFM Watts	1215 142	1216 196	1210 255	1211 314	1215 369
	HIGH	440 CFM/ton	ON	ON	ON	OFF	CFM Watts	1333 178	1338 238	1333 300	1331 365	1332 428
3.5	LOW	348 CFM/ton	OFF	ON	OFF	ON	CFM Watts	1232 147	1234 202	1228 261	1229 322	1233 377
	NORMAL	387 CFM/ton	OFF	ON	OFF	OFF	CFM Watts	1366 189	1373 252	1369 314	1366 381	1365 447
	HIGH	426 CFM/ton	OFF	ON	ON	OFF	CFM Watts	1500 238	1511 311	1510 377	1502 449	1498 529
4	LOW	338 CFM/ton	ON	OFF	OFF	ON	CFM Watts	1364 188	1370 251	1366 313	1363 379	1363 446
	NORMAL	375 CFM/ton	ON	OFF	OFF	OFF	CFM Watts	1509 241	1520 315	1519 382	1511 453	1506 535
	HIGH	413 CFM/ton	ON	OFF	ON	OFF	CFM Watts	1659 305	1674 395	1676 466	1662 541	1654 632

Performance and Electrical Data

Table 2. Air Flow Performance (continued)

A4AH6V48A1C30B HEATING AIRFLOW PERFORMANCE, NO FILTER, NO HEATER												
5	LOW	326 CFM/ton	OFF	OFF	OFF	ON	CFM Watts	1637 295	1652 383	1653 453	1641 528	1632 618
	NORMAL (a)	362 CFM/ton	OFF	OFF	OFF	OFF	CFM Watts	1814 381	1834 493	1839 570	1820 645	1807 730
	HIGH	398 CFM/ton	OFF	OFF	ON	OFF	CFM Watts	1990 481	2017 625	2025 713	2000 779	1982 826

(a) Factory Default Setting

Table 3. Electrical Data

A4AH6V48A1C30B											
Heater Model No.	No. of Circuits/ Phases	240 Volt					208 Volt				
		Capacity		Heater Amps per Circuit	Minimum Circuit Ampacity	Maximum Overload Protection	Capacity		Heater Amps per Circuit	Minimum Circuit Ampacity	Maximum Overload Protection
		kW	BTUH				kW	BTUH			
No Heater				6.8 *	9	15			6.8 *	9	15
BAYHTR1504BRK BAYHTR1504LUG	1/1	3.84	13100	16.0	29	30	2.88	9800	13.8	26	30
BAYHTR1505BRK BAYHTR1505LUG	1/1	4.80	16400	20.0	34	35	3.60	12300	17.3	30	30
BAYHTR1508BRK BAYHTR1508LUG	1/1	7.68	26200	32.0	49	50	5.76	19700	27.7	43	45
BAYHTR1510BRK BAYHTR1510LUG	1/1	9.60	32800	40.0	59	60	7.20	24600	34.6	52	60
BAYHTR1517BRK Circuit 1 (a)	2/1	9.60	32800	40.0	59	60	7.20	24600	34.6	52	60
BAYHTR1517BRK Circuit 2		4.80	16400	20.0	25	25	3.60	12300	17.3	22	25
BAYHTR1523BRK Circuit 1	2/1	9.60	32800	40.0	59	60	7.20	24600	34.6	52	60
BAYHTR1523BRK Circuit 2		9.60	32800	40.0	50	50	7.20	24600	34.6	43	45
BAYHTR1525BRK Circuit 1	4/1	6.00	20500	25.0	40	40	4.50	15400	21.6	36	40
BAYHTR1525BRK Circuit 2		6.00	20500	25.0	31	35	4.50	15400	21.6	27	30
BAYHTR1525BRK Circuit 3		6.00	20500	25.0	31	35	4.50	15400	21.6	27	30
BAYHTR1525BRK Circuit 4		6.00	20500	25.0	31	35	4.50	15400	21.6	27	30
BAYHTR3510LUG	1/3	9.60	32800	23.1	36	40	7.20	24600	20.0	33	35
BAYHTR3517LUG	1/3	14.40	49100	34.6	51	60	10.80	36900	30.0	45	45

* = Motor Amps

(a) MCA and MOP for circuit 1 contains the motor amps

Features and Benefits

- Galvanized metal cabinet with captured foil face insulation
- 2% or less air leakage
- R-4.2 Insulating Value
- Multi-Position UP/Down Flow, Horizontal Left /Right
- ALL Aluminum Coil
- Electric Heaters with polarized plug connections (sold as accessory)
- R-410A Thermal Expansion Valve
- Variable Speed ECM Motor
- Low Voltage Pigtail Connections

- Draw Through Design
- Horizontal Drain pan
- Single Color
- Fused 24V Power
- **5 year warranty**
- **Optional extended warranty available**

Important: *Condensate management kit is required for all 5 ton air handler models installed in downflow applications.*

About Trane and American Standard Heating and Air Conditioning

Trane and American Standard create comfortable, energy efficient indoor environments for residential applications. For more information, please visit www.trane.com or www.americanstandardair.com.



The manufacturer has a policy of continuous data improvement and it reserves the right to change design and specifications without notice. We are committed to using environmentally conscious print practices.