

Submittal

**4.0 Ton
Variable Speed Convertible Air Handler
A4AH6V48A1D30A**

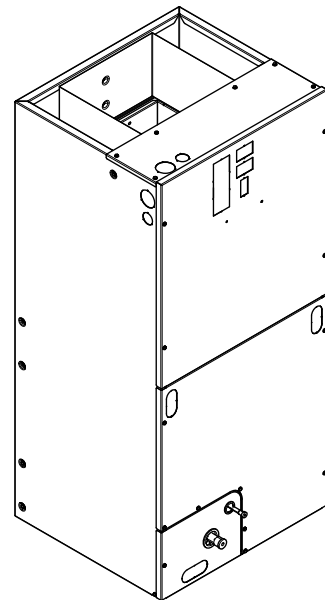

Outline Drawing

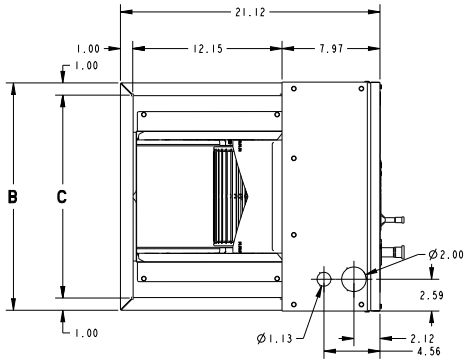

MINIMUM UNIT CLEARANCE TABLE	
	SERVICE CLEARANCE (RECOMMENDED)
SIDES	2"
FRONT	21"
BACK	0"
INLET DUCT	1"
OUTLET DUCT	N/A

NOTE: THIS UNIT IS APPROVED FOR INSTALLATION CLEARANCES TO COMBUSTIBLE MATERIAL AS STATED ON THE UNIT RATING NAMEPLATE

ALL DIMENSIONS ARE REFERENCE DIMENSIONS

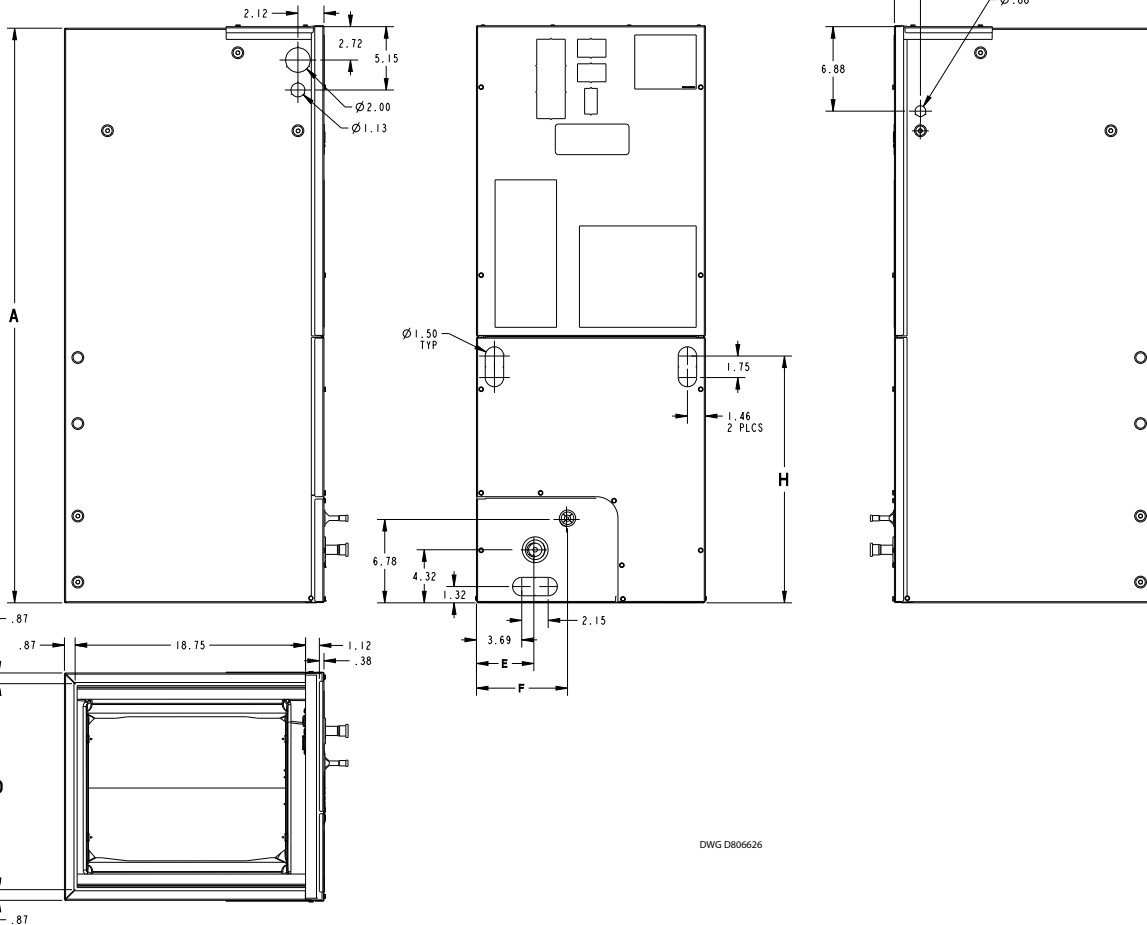

DWG D806626

PRODUCT DIMENSIONS									
Air Handler Model	A	B	C	D	E	F	H	Flow Control	Gas Line Braze
A4AH6V48A1D	53.87	26.50	24.50	24.75	7.01	9.66	27.19	TXV	7/8
All dimensions are in inches									

Product Specifications

MODEL	A4AH6V48A1D30A
RATED VOLTS/PH/HZ	208-230/1/60
RATINGS^(a)	See O.D. Specifications
INDOOR COIL — Type	Plate Fin
Rows — F.P.I.	4 - 16
Face Area (sq. ft.)	6.47
Tube Size (in.)	3/8
Refrigerant Control	TXV
Drain Conn. Size (in.) ^(b)	3/4 NPT
DUCT CONNECTIONS	See Outline Drawing
INDOOR FAN — Type	Centrifugal
Diameter-Width (In.)	11 X 11
No. Used	1
Drive - No. Speeds	Direct - 16
CFM vs. in. w.g.	See Fan Performance Table
No. Motors — H.P.	1 - 3/4
Motor Speed R.P.M.	Variable
Volts/Ph/Hz	208-230/1/60

F.L. Amps	6.8
FILTER	
Filter Furnished? ^(c)	No
REFRIGERANT	R-410A
Ref. Line Connections	Brazed
Coupling or Conn. Size — in. Gas	7/8
Coupling or Conn. Size — in. Liq.	3/8
DIMENSIONS	H x W x D
Crated (In.)	55-3/8 x 30-1/2 x 25-1/2
Uncrated	53-7/8 x 26-1/2 x 21-1/8
WEIGHT	
Shipping (Lbs.) / Net (Lbs.)	181/168

^(a) These Air Handlers are A.H.R.I certified with various Split System Air Conditioners and Heat Pumps (AHRI STANDARD 210/240). Refer to the Split System Outdoor Unit Product Data Guides for performance data.

^(b) 3/4" Male Plastic Pipe (Ref: ASTM 1785-76)

^(c) Remote filter required.

Minimum Airflow CFM

A4AH6V48A1D30A		
Heater	Minimum Heater Airflow CFM	
	With Heat Pump	Without Heat Pump
BAYHTR1504BRK, BAYHTR1504LUG BAYHTR1505BRK, BAYHTR1505LUG	1150	975
BAYHTR1508BRK, BAYHTR1508LUG	1150	975
BAYHTR1510BRK, BAYHTR1510LUG	1150	975
BAYHTR1517BRK	1300	1125
BAYHTR3510LUG	1150	975
BAYHTR3517LUG	1300	1125
BAYHTR1523BRK	1380	1125
BAYHTR1525BRK	1550	1345

A4AH6V48A1D30A Airflow Performance with Auxiliary Heat				
Airflow Settings	Dip Switch Settings		Nominal Airflow	See following tables for heater application: - Pressure Drop for Electrical Heaters - Minimum Heating Airflow Matrix (on unit nameplates)
	Switch 7	Switch 8		
Low	ON	ON	997	
Med-Lo	OFF	ON	1129	
Med-Hi	ON	OFF	1350	
High	OFF	OFF	1597	

Heater Pressure Drop Table

Airflow CFM	Number of Racks				Heater Racks	
	1	2	3	4	Heater Model	No. of Racks
	Air Pressure Drop — Inches W.G.					
1800	0.02	0.04	0.06	0.14	BAYHTR1504	1
1700	0.02	0.04	0.06	0.14	BAYHTR1505	1
1600	0.02	0.04	0.06	0.13	BAYHTR1508	2
1500	0.02	0.04	0.06	0.12	BAYHTR1510	2
1400	0.02	0.04	0.06	0.12	BAYHTR1517	3
1300	0.02	0.04	0.05	0.11	BAYHTR3510	3
1200	0.01	0.04	0.05	0.10	BAYHTR3517	3
1100	0.01	0.03	0.05	0.09	BAYHTR3515	3
1000	0.01	0.03	0.04	0.09	BAYHTR1523	4
900	0.01	0.03	0.04	0.08	BAYHTR1525	4
800	0.01	0.03				
700	0.01	0.02				
600	0.01	0.02				

Performance and Electrical Data

1. See Product Data or Air Handler nameplate for approved combinations of Air Handlers and Heaters.
2. Heater model numbers may have additional suffix digits.

Table 1. Air Flow Performance

A4AH6V48A1D30A COOLING AIRFLOW PERFORMANCE, WET COIL, NO FILTER, NO HEATER												
OUTDOOR UNIT SIZE (TONS)	SPEED SETTING	AIRFLOW SETTING	DIP SWITCH SETTING				AIRFLOW POWER	EXTERNAL STATIC PRESSURE				
			SW1	SW2	SW3	SW4		0.1	0.3	0.5	0.7	0.9
3	LOW	323 CFM/ton	ON	ON	OFF	ON	CFM Watts	979 87	978 126	959 170	922 217	867 269
	NORMAL	367 CFM/ton	ON	ON	OFF	OFF	CFM Watts	1111 124	1113 168	1101 215	1075 265	1036 317
	HIGH	415 CFM/ton	ON	ON	ON	OFF	CFM Watts	1252 165	1259 214	1254 264	1239 314	1212 364
3.5	LOW	315 CFM/ton	OFF	ON	OFF	ON	CFM Watts	1111 124	1113 168	1101 215	1075 265	1036 317
	NORMAL	358 CFM/ton	OFF	ON	OFF	OFF	CFM Watts	1259 167	1266 217	1261 267	1246 317	1220 368
	HIGH	404 CFM/ton	OFF	ON	ON	OFF	CFM Watts	1419 223	1428 279	1425 334	1411 389	1386 444
4	LOW	309 CFM/ton	ON	OFF	OFF	ON	CFM Watts	1241 161	1248 210	1243 259	1227 309	1201 359
	NORMAL	351 CFM/ton	ON	OFF	OFF	OFF	CFM Watts	1407 218	1416 273	1413 328	1399 383	1373 437
	HIGH	396 CFM/ton	ON	OFF	ON	OFF	CFM Watts	1583 296	1593 359	1594 422	1586 485	1570 547
5	LOW	295 CFM/ton	OFF	OFF	OFF	ON	CFM Watts	1478 249	1487 307	1486 365	1474 423	1452 481
	NORMAL ^(a)	335 CFM/ton	OFF	OFF	OFF	OFF	CFM Watts	1671 344	1681 412	1684 479	1678 545	1635 565
	HIGH	379 CFM/ton	OFF	OFF	ON	OFF	CFM Watts	1880 476	1892 556	1900 635	1902 714	1760 650

^(a) Factory Default Setting

Table 2. Air Flow Performance

A4AH6V48A1D30A HEATING AIRFLOW PERFORMANCE, NO FILTER, NO HEATER												
OUTDOOR UNIT SIZE (TONS)	SPEED SETTING	AIRFLOW SETTING	DIP SWITCH SETTING				AIRFLOW POWER	EXTERNAL STATIC PRESSURE				
			SW1	SW2	SW3	SW4		0.1	0.3	0.5	0.7	0.9
3	LOW	360 CFM/ton	ON	ON	OFF	ON	CFM Watts	1087 111	1091 153	1081 199	1055 249	1015 301
	NORMAL	400 CFM/ton	ON	ON	OFF	OFF	CFM Watts	1205 139	1213 186	1211 234	1198 283	1173 333
	HIGH	440 CFM/ton	ON	ON	ON	OFF	CFM Watts	1322 175	1333 227	1332 279	1321 332	1297 384
3.5	LOW	347 CFM/ton	OFF	ON	OFF	ON	CFM Watts	1219 143	1228 191	1226 240	1213 289	1189 339
	NORMAL	386 CFM/ton	OFF	ON	OFF	OFF	CFM Watts	1351 184	1363 237	1363 290	1351 344	1328 397
	HIGH	424 CFM/ton	OFF	ON	ON	OFF	CFM Watts	1482 232	1495 291	1497 349	1489 408	1471 466
4	LOW	351 CFM/ton	ON	OFF	OFF	ON	CFM Watts	1405 201	1417 256	1418 311	1408 367	1385 422
	NORMAL	390 CFM/ton	ON	OFF	OFF	OFF	CFM Watts	1555 262	1568 323	1572 385	1567 447	1553 509
	HIGH	429 CFM/ton	ON	OFF	ON	OFF	CFM Watts	1703 334	1717 403	1723 472	1722 540	1665 560

Performance and Electrical Data

Table 2. Air Flow Performance (continued)

A4AH6V48A1D30A HEATING AIRFLOW PERFORMANCE, NO FILTER, NO HEATER												
5	LOW	327 CFM/ton	OFF	OFF	OFF	ON	CFM Watts	1625 294	1639 359	1644 424	1641 489	1630 554
	NORMAL (a)	363 CFM/ton	OFF	OFF	OFF	OFF	CFM Watts	1797 384	1812 459	1820 533	1822 606	1750 615
	HIGH	400 CFM/ton	OFF	OFF	ON	OFF	CFM Watts	1970 495	1986 581	1999 667	2010 740	1910 680

(a) Factory Default Setting

Table 3. Electrical Data

A4AH6V48A1D30A											
Heater Model No.	No. of Circuits/ Phases	240 Volt					208 Volt				
		Capacity		Heater Amps per Circuit	Minimum Circuit Ampacity	Maximum Overload Protection	Capacity		Heater Amps per Circuit	Minimum Circuit Ampacity	Maximum Overload Protection
		kW	BTUH				kW	BTUH			
No Heater				6.8 *	9	15			6.8 *	9	15
BAYHTR1504BRK BAYHTR1504LUG	1/1	3.84	13100	16.0	29	30	2.88	9800	13.8	26	30
BAYHTR1505BRK BAYHTR1505LUG	1/1	4.80	16400	20.0	34	35	3.60	12300	17.3	30	30
BAYHTR1508BRK BAYHTR1508LUG	1/1	7.68	26200	32.0	49	50	5.76	19700	27.7	43	45
BAYHTR1510BRK BAYHTR1510LUG	1/1	9.60	32800	40.0	59	60	7.20	24600	34.6	52	60
BAYHTR1517BRK Circuit 1 (a)	2/1	9.60	32800	40.0	59	60	7.20	24600	34.6	52	60
BAYHTR1517BRK Circuit 2		4.80	16400	20.0	25	25	3.60	12300	17.3	22	25
BAYHTR1523BRK Circuit 1	2/1	9.60	32800	40.0	59	60	7.20	24600	34.6	52	60
BAYHTR1523BRK Circuit 2		9.60	32800	40.0	50	50	7.20	24600	34.6	43	45
BAYHTR1525BRK Circuit 1	4/1	6.00	20500	25.0	40	40	4.50	15400	21.6	36	40
BAYHTR1525BRK Circuit 2		6.00	20500	25.0	31	35	4.50	15400	21.6	27	30
BAYHTR1525BRK Circuit 3		6.00	20500	25.0	31	35	4.50	15400	21.6	27	30
BAYHTR1525BRK Circuit 4		6.00	20500	25.0	31	35	4.50	15400	21.6	27	30
BAYHTR3510LUG	1/3	9.60	32800	23.1	36	40	7.20	24600	20.0	33	35
BAYHTR3517LUG	1/3	14.40	49100	34.6	51	60	10.80	36900	30.0	45	45

* = Motor Amps

(a) MCA and MOP for circuit 1 contains the motor amps

Features and Benefits

- Galvanized metal cabinet with captured foil face insulation
- 2% or less air leakage
- R-4.2 Insulating Value
- Multi-Position UP/Down Flow, Horizontal Left /Right
- ALL Aluminum Coil with Enhanced Patented Coil Fin
- Electric Heaters with polarized plug connections (sold as accessory)
- R-410A Thermal Expansion Valve
- Variable Speed ECM Motor
- Low Voltage Pigtail Connections
- Draw Through Design
- Horizontal Drain pan
- Single Color
- Fused 24V Power
- **5 year warranty**
- **Optional extended warranty available**

Important: Condensate management kit is required for all 5 ton air handler models installed in downflow applications.

About Trane and American Standard Heating and Air Conditioning

Trane and American Standard create comfortable, energy efficient indoor environments for residential applications. For more information, please visit www.trane.com or www.americanstandardair.com.



The manufacturer has a policy of continuous data improvement and it reserves the right to change design and specifications without notice. We are committed to using environmentally conscious print practices.