

TAG: \_\_\_\_\_

# Specification

**Upflow / Horizontal  
Gas Furnace - Variable  
Speed - 2 Stage Heat**

**AUD2B060A9V3VB**

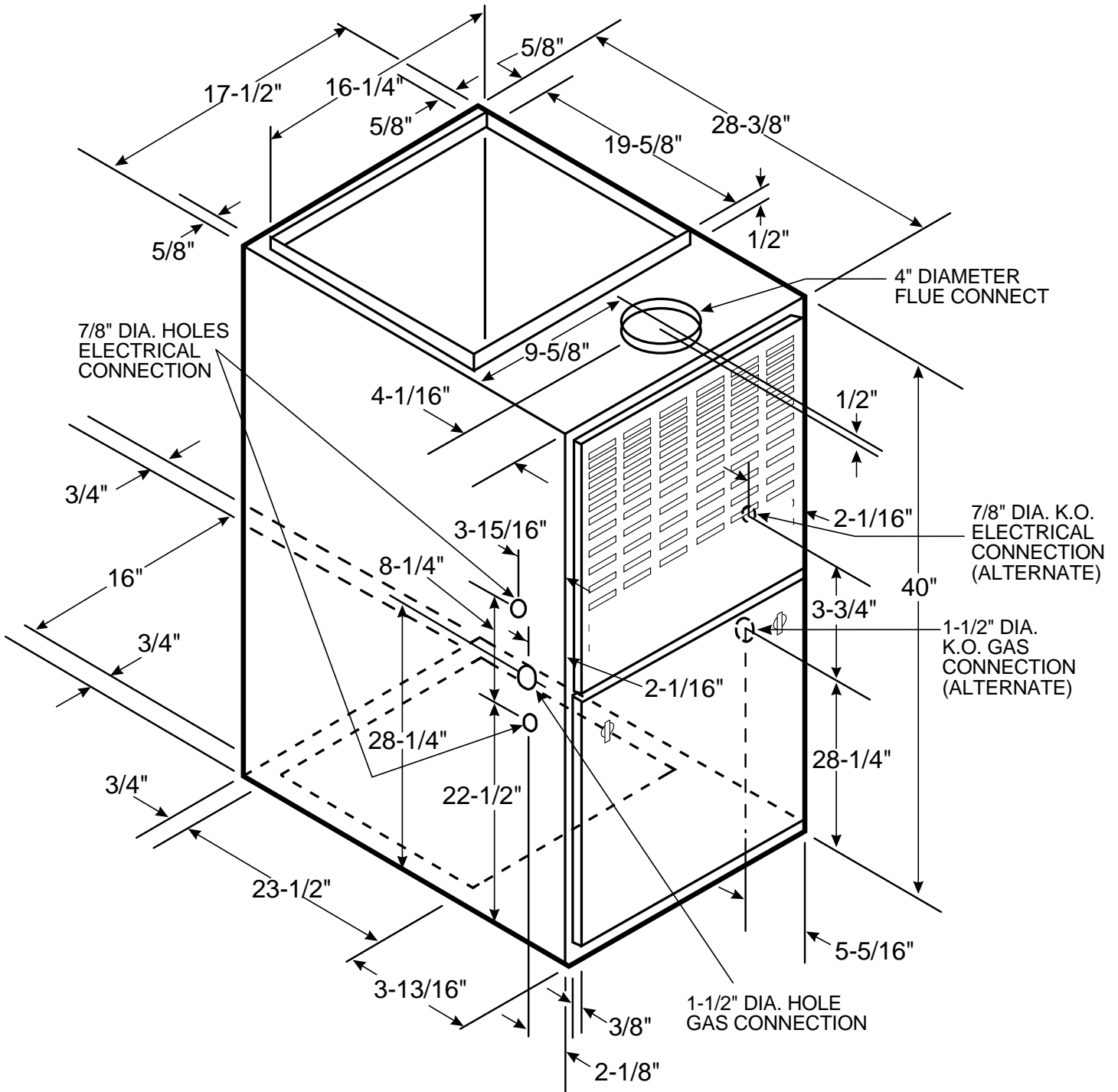

<b>*UD2B060A9V3VB FURNACE HEATING AIRFLOW (CFM) AND POWER (WATTS) VS. EXTERNAL STATIC PRESSURE WITH FILTER</b>									
	AIRFLOW SETTING	DIP SWITCH SETTING			EXTERNAL STATIC PRESSURE				
		SW7	SW8		0.1	0.3	0.5	0.7	0.9
HEATING 1ST STAGE	LOW	ON	ON	CFM	589	604	619	604	607
				TEMP. RISE	49	48	47	48	48
				WATTS	65	95	125	160	200
	MEDIUM **	ON	OFF	CFM	663	694	684	681	686
				TEMP. RISE	44	42	42	42	42
				WATTS	75	120	145	185	220
	HIGH	OFF	OFF	CFM	775	781	776	805	811
				TEMP. RISE	37	37	37	36	36
				WATTS	105	145	180	230	270
HEATING 2ND STAGE	LOW	ON	ON	CFM	813	818	818	837	842
				TEMP. RISE	55	54	54	53	53
				WATTS	110	150	185	240	280
	MEDIUM **	ON	OFF	CFM	907	919	942	958	959
				TEMP. RISE	49	48	47	46	46
				WATTS	140	200	240	300	330
	HIGH	OFF	OFF	CFM	1038	1066	1086	1089	1079
				TEMP. RISE	43	42	41	41	41
				WATTS	190	260	325	365	415

<b>*UD2B060A9V3VB FURNACE COOLING AIRFLOW (CFM) AND POWER (WATTS) VS. EXTERNAL STATIC PRESSURE WITH FILTER</b>											
OUTDOOR UNIT SIZE (TONS)	AIRFLOW SETTING	DIP SWITCH SETTING					EXTERNAL STATIC PRESSURE				
		SW1	SW2	SW3	SW4		0.1	0.3	0.5	0.7	0.9
1.5	LOW (350 CFM/TON)	ON	ON	OFF	ON	CFM	499	537	520	520	500
						WATTS	50	80	110	145	175
	NORMAL (400 CFM/TON)	ON	ON	OFF	OFF	CFM	605	610	610	597	593
						WATTS	60	80	120	155	180
	HIGH (450 CFM/TON)	ON	ON	ON	OFF	CFM	649	681	665	665	672
						WATTS	75	110	145	180	220
2	LOW (350 CFM/TON)	OFF	ON	OFF	ON	CFM	680	722	680	696	696
						WATTS	80	125	150	190	225
	NORMAL (400 CFM/TON)	OFF	ON	OFF	OFF	CFM	798	804	809	823	818
						WATTS	105	145	170	235	280
	HIGH (450 CFM/TON)	OFF	ON	ON	OFF	CFM	884	896	924	931	931
						WATTS	145	180	240	280	330
2.5	LOW (350 CFM/TON)	ON	OFF	OFF	ON	CFM	858	863	882	894	895
						WATTS	125	175	220	275	320
	NORMAL (400 CFM/TON)	ON	OFF	OFF	OFF	CFM	984	1017	1038	1017	1017
						WATTS	170	225	295	330	375
	HIGH (450 CFM/TON)	ON	OFF	ON	OFF	CFM	1125	1138	1150	1161	1161
						WATTS	245	315	370	435	475
3 **	LOW (350 CFM/TON)	OFF	OFF	OFF	ON	CFM	1035	1056	1076	1076	1076
						WATTS	205	265	330	370	430
	NORMAL (400 CFM/TON)	OFF	OFF	OFF	OFF	CFM	1208	1247	1268	1278	1200
						WATTS	300	360	440	485	490
	HIGH (450 CFM/TON)	OFF	OFF	ON	OFF	CFM	1380	1410	1402	1350	1235
						WATTS	440	500	550	550	525

**NOTES:**

- \*FIRST LETTER MAY BE "A" OR "T"
- \*\*FACTORY SETTING.
- CONTINUOUS FAN SETTING: HEATING OR COOLING AIRFLOW IS APPROXIMATELY 50% OF SELECTED COOLING VALUE.
- FOR VARIABLE SPEED: LOW SPEED AIRFLOWS ARE APPROXIMATELY 30% OF LISTED VALUES.
- LOW 350 CFM/TON IS RECOMMENDED FOR VARIABLE SPEED APPLICATION FOR COMFORT & HUMID CLIMATE SETTING: NORMAL IS 400 CFM/TON: HIGH 450 CFM/TON IS FOR DRY CLIMATE SETTING.

## INDOOR BLOWER TIMING

**Heating:** The ECM Fan Control controls the variable speed indoor blower. The blower "on" time is fixed at 45 seconds after ignition. The FAN-OFF period is field selectable by dip switches #2 and #3 on the Integrated Furnace Control at 60, 100, 140, or 180 seconds. The factory setting is 100 seconds. (See unit wiring diagram).

**Cooling:** The fan delay-off period is set by dip switches on the ECM Fan Control board connected to the Integrated Furnace Control. The options for cooling delay off is field selectable by dip switches #5 and #6. However, dip switch #1 on the Integrated Furnace Control must be set to "ON" for cooling mode to function properly.

The following table and graph explain the delay-off settings:

\*\* - This selection provides a ramping up and ramping down of the blower speed to provide improved comfort, quietness, and potential energy savings. The graph below shows the ramping process.

## COOLING OFF - DELAY OPTIONS

SWITCH SETTINGS		SELECTION	NOMINAL AIRFLOW
5 - OFF	6 - OFF	NONE	SAME
5 - ON	6 - OFF	1.5 MINUTES	100% *
5 - OFF	6 - ON	3 MINUTES	50%
5 - ON	6 - ON	**	50 - 100%

\* - This setting is equivalent to BAY24X045 relay benefit

\*\* - This selection provides **ENHANCED MODE**, which is a ramping up and ramping down of the blower speed to provide improved comfort, quietness, and potential energy savings. See Wiring Diagram notes on the unit or in the Service Facts for complete wiring setup for **ENHANCED MODE**. The graph which follows, shows the ramping process.

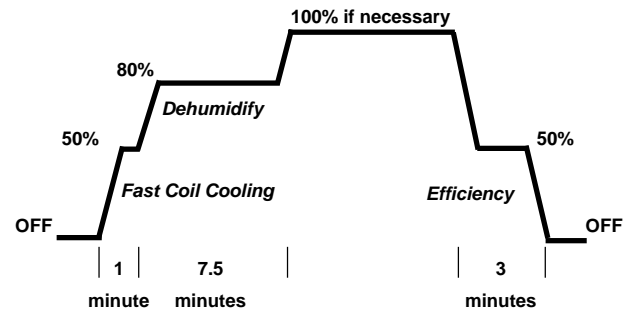

## General Data ①

TYPE	Upflow / Horizontal
<b>RATINGS 2</b>	
1st Stage Input BTUH	39,000
1st Stage Capacity BTUH (ICS) 3	31,200
2nd Stage Input BTUH	60,000
2nd Stage Capacity BTUH (ICS) 3	48,000
Temp. rise (Min.-Max.) °F.	30 - 60
<b>BLOWER DRIVE</b>	
	DIRECT
Diameter-Width (In.)	10 x 7
No. Used	1
Speeds (No.)	VARIABLE SPEED
CFM vs. in. w.g.	See Fan Performance
Motor HP	1/2
R.P.M.	VARIABLE
Volts/Ph/Hz	115/1/60
<b>COMBUSTION FAN - Type</b>	
	Centrifugal
Drive - No. Speeds	Direct - 2
Motor HP - RPM	1/100 - 2543 / 1727
Volts/Ph/Hz	115/1/60
F.L. Amps	0.70 / 0.40
<b>FILTER — Furnished?</b>	
	Yes
Type Recommended	High Velocity
Hi Vel. (No.-Size-Thk.) Shipped	1 - 17 x 25 - 1in.

<b>VENT COLLAR — Size (in.)</b>	4 Round
<b>HEAT EXCHANGER</b>	
Type-Fired	Alum. Steel
-Unfired	
Gauge (Fired)	20
<b>ORIFICES — Main</b>	
Nat. Gas. Qty. — Drill Size	3 — 45
L.P. Gas Qty. — Drill Size	3 — 56
<b>GAS VALVE</b>	Redundant - Two Stage
<b>PILOT SAFETY DEVICE</b>	
Type	Hot Surface Ignition
<b>BURNERS — Type</b>	
	Multiport Inshot
Number	3
<b>POWER CONN. — V/Ph/Hz ④</b>	
	115/1/60
Ampacity (In Amps)	10.5
Max. Overcurrent Protection (amps)	15
<b>PIPE CONN. SIZE (IN.)</b>	
	1/2
<b>DIMENSIONS</b>	
	H x W x D
Crated (In.)	41- 3/4 x 19-1/2 x 30-1/2
Uncrated (In.)	40 x 17-1/2 x 28-1/2
<b>WEIGHT</b>	
Shipping (Lbs.) / Net (Lbs)	136 / 126

① Central Furnace heating designs are certified to ANSI Z21.47 / CSA 2.3

② Ratings shown are for elevations up to 2000 feet. For elevations above 2000 feet; Ratings should be reduced at the rate of 4% for each 1000 feet above sea level.

③ Based on U.S. Government Standard Tests.

④ The above wiring specifications are in accordance with National Electrical Code; however, installations must comply with local codes.

# Mechanical Specifications

**NATURAL GAS MODELS** — Central heating furnace designs are certified to ANSI Z21.47 / CSA 2.3 for both natural and L.P. gas. Limit setting and rating data were established and approved under standard rating conditions using American National Standards Institute standards.

**SAFE OPERATION** — The Integrated System Control has solid state devices, which continuously monitor for presence of flame, when the system is in the heating mode of operation. Dual solenoid combination gas valve and regulator provide extra safety.

**QUICK HEATING**— Durable, cycle tested, heavy gauge **aluminized steel heat exchanger** quickly transfers heat to provide warm conditioned air to the structure. **Low energy power vent blower**, to increase efficiency and provide discharge of gas fumes to the outside, allows common venting with hot water heater.

**BURNERS** — Multi-port, in-shot burners will give years of quiet and efficient service. All models can be converted to **L.P. gas** without changing burners.

**INTEGRATED SYSTEM CONTROL**— Exclusively designed operational program provides total control of furnace limit sensors, blowers, gas valve, flame control and includes self diagnostics for ease of service.

**AIR DELIVERY** — The variable speed, direct-drive blower motor, with sufficient air-flow range for most heating and cooling requirements, will switch from heating to cooling speeds on demand from room thermostat. The blower door safety switch will prevent or terminate furnace operation when the blower door is removed. (Fan relay and 35VA control transformer is standard).

**STYLING**— **Heavy gauge steel and "wrap-around" cabinet construction** is used in the cabinet with baked-on enamel finish for strength and beauty. The heat exchanger section of the cabinet is completely lined with foil-faced fiberglass insulation. This results in quiet and efficient operation due to the excellent acoustical and insulating qualities of fiberglass.

**FEATURES AND GENERAL OPERATION** — These High Efficiency Gas Furnaces employ a Hot Surface Ignition system, which eliminates the waste of a constantly burning pilot. The integrated system control lights the main burners upon a demand for heat from the room thermostat. Complete front service access.

- a. Low energy power venter.
- b. Vent proving differential switch.

*American Standard*  
HEATING & AIR CONDITIONING

Since American Standard Heating & Air Conditioning has a policy of continuous product and product data improvement, it reserves the right to change specifications and design without notice.

Technical Literature - Printed in U.S.A.

**American Standard**  
**Heating & Air Conditioning**  
6200 Troup Highway  
Tyler, TX 75707



Library	-
Product Section	-
Product	Furnace
Model	AUD2-9V
Literature Type	Specification
Sequence	-
Date	08/10
File No.	AUD2B060A9V-SPEC-1
Supersedes	AUD060R9V-SPEC-1