

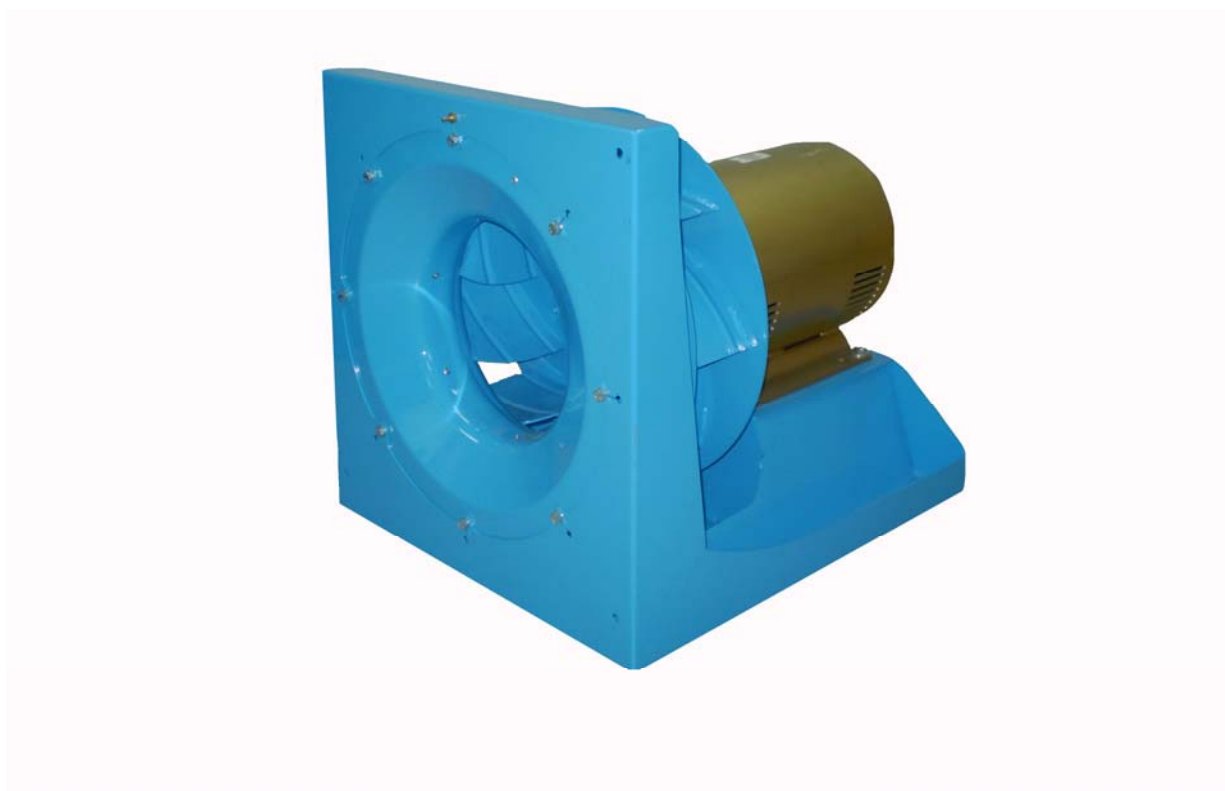

comefri

ATE-ANPL-ANPA

Fan Installation, Operation &
Maintenance





ATE-ANPL-ANPA

Fan Installation, Operation & Maintenance

This document contains information on proper storage, installation, operation and general maintenance of Comefri USA fans ATE, ANPL, ANPA. Failure to comply with proper installation procedures may void the warranty. The technical data and the permissible limits of the fan are clearly listed on the fan plate. All fans are balanced and tested before leaving the factory.

All Comefri USA Fans are manufactured according to our Quality Management System, in conformity with ISO 9001:2000. Comefri USA Quality System is certified by BSI.

Receiving and Handling

Each fan is carefully checked before shipment. When receiving a fan it is necessary to verify that it has not been damaged during transit, especially the rotating parts and any electric part (Motor). In case of damage, immediately document the damage on the delivery notes and contact the delivery company. Comefri will not take any responsibility for the transport and the handling of the fan at the customer's premises. The handling of the fan requires adequate care. Lifting tools according to the weight and packaging of the fan should be used. When moving the fan with crane, four lifting points have to be provided.

Special care must be taken to ensure that the fan will never be lifted by the shaft ends, motor lifting lug, bearing supports and/or inlet or outlet flanges. Fixing points of the fans are the base frame, housing frames or lifting eyes if available.

Note: Any improper handling, even though it may not visually damage the fan, often produces a need to re-balance the impeller.

Storage

Adequate storage must be provided to protect the fan from dirt and moisture. Do not use plastic sheets, as they will promote condensation and rust especially in hot and humid environments. Indoor storage is recommended. Store in a dry, clean area. Storage temperature should range between -4 °F and +113 °F.

Vibration Isolation Base

High vibrations can cause mechanical and structural failure. Bases must have sufficient rigidity to prevent the generation of vibrations and resonances while supporting the fan and motor. Isolators are used to reduce and prevent vibrations and noises from being transferred to the surrounding structure. When properly selected the isolators will attenuate the vibration forces transmitted to the surrounding structure by approximately 90%.

Fan Foundations

Many fan problems are caused by a poorly designed foundation. The foundation must be strong enough to hold the weight of the fan, motor, isolation base plus the loads created by its running. The natural frequency of the foundation should be at least twice the natural frequency of the base isolators.

Installation

Installation is only to be carried out by trained personnel in observance of these operating instructions. The fans must be firmly fixed on isolation base frames. The fixing must be made avoiding any stress or deformation of the supporting structure.

Duct Connections

It is important to design proper ducting. Poor ducting can affect the fan performances reducing the volume flow and pressure and increasing the system noise.

Inlet Connections

Inlet spin is caused by improper ducting on the inlet of the fan and will result in a reduction in fan performance. The change in performance is directly related to the amount of the spin. Installing elbows or duct turns too close to the fan inlet will also affect the fan performance. If the elbow is too close to the fan inlet, the air will flow uneven into the fan. Allowing at least one wheel diameter from the elbow to the fan inlet will produce a uniform inlet flow distribution. In installations where the inlet is un-ducted, there should be a least half wheel diameter of free space on the inlet side, as shown in figure 1.



comefri

ATE-ANPL-ANPA

Fan Installation, Operation & Maintenance

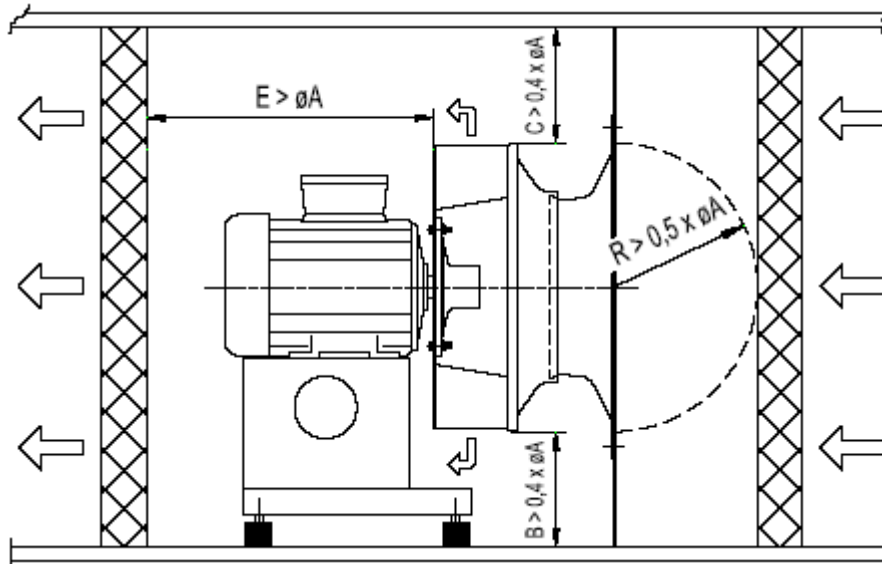

Figure 1

Fans that are mounted on vibration isolators will require flex connectors. These are used to avoid the transferring of vibration and sound into the system. Improperly mounted flex connectors will also cause a system effect.

Electrical Wiring

The connection of the motor terminal box must be made in accordance with the information given by the motor manufacturer.

Startup & Safety Checks

Particular attention must be paid to safety. Be sure to isolate electrical power before working on the fan. Check that all nuts, bolts, and set-screws are tightened. The fan should be switched on briefly to check the direction of rotation of the impeller, which should correspond to the one indicated by the arrow.

Should the motor run in the wrong direction, interchanging any two of the three electrical leads would reverse the direction of rotation of the three phase motors. Changing the internal connections, as described on the motor label or wiring diagram, can reverse single-phase motors. Always observe the electrical safety instructions.

Following is a pre-start checklist that should be followed before starting any fan.

Pre-Start Check List

- _ Make sure electrical power is isolated.
- _ Check power settings for voltage and verify that correspond with the data on the motor plate.
- _ Check that Motor is grounded.
- _ Check that all electrical leads are sufficiently insulated.
- _ Check the ducts and the fan for extraneous material (tools, small components, etc.)
- _ Check that all electrical and system connections are properly made and tightened.
- _ Check that all nuts, bolts, and set-screws are tightened.
- _ Check that the Wheel turns freely without rubbing.
- _ "Bump the Assembly" - turn it on - then off, quickly.
- _ Check rotation.

Lubrication

Refer to the motor manufacturer requirement for the appropriate grease and lubrication frequency.

Fan maintenance

The fans are designed to operate with clean air. Some amount of dirt can be expected on the impeller ('build up' of materials, dust). Regular inspection and cleaning must take place. No high-pressure cleaners (steam rod cleaners) are to be used.



ATE-ANPL-ANPA

Fan Installation, Operation & Maintenance

Periodical Inspection

The following periodical inspections are recommended:

- _ Clean the wheel.
- _ Check that all nuts, bolts, and set-screws are tightened.

Comefri declines any responsibility for damages and inconveniences, which can be sustained as direct or indirect consequences of methods, procedures and applications in contradiction or not in full correspondence with the instructions and guidelines given in this document. Comefri reserves the right to modify and update this document without any duty to give notice to the previous users. For any further information and clarification concerning the above contents, contact Comefri USA at 270 881-1444.