



# PHS

## Product Specifications

### 10 SEER COMMERCIAL PACKAGE HEAT PUMP UNIT R-22, SINGLE PACKAGE ROOFTOP, 3 - 5 TONS, (3-Phase)

#### BUILT TO LAST, EASY TO INSTALL AND SERVICE

- One-piece, high efficiency heat pump with a low profile, prewired, tested, and charged at the factory.
- Field convertible supply and return openings are intended for installation on a roof top or ground level.
- Scroll compressors on all sizes
- Liquid line filter drier
- Non-corrosive condensate pan with self-draining sloping design and bottom or side drain connections
- Loss-of-charge, freeze protection, and high pressure safety switches
- Single-point electrical connections on field installed electric heat units
- Direct drier models standard
- Direct-drive propeller outdoor fan totally enclosed with permanently lubricated bearings
- Prepainted, galvanized steel cabinet with primer inner panels, certified at 500-hr salt spray test and noncorrosive screws
- Large, easily removable panels provide ready access to components for removal or maintenance
- Two inch disposable type return air filters in dedicated rack with filter access door requiring no tools
- Four-way valve operation
- Low outdoor temperature cooling operation 25°F to 125°F
- Fixed orifice metering devices precisely control flow to circuits individually
- State of the art defrost control board, easily configured for defrost cycles at 30, 50, or 90 minutes
- 24-Volt control circuit with circuit breaker
- Thru-the-bottom power entry capability
- Indoor and outdoor coils constructed of aluminum fins mechanically bonded to seamless copper tubes
- Factory-run test printout included in each rooftop



PHS036-060

#### WARRANTY

- 5 Year compressor limited warranty
- 1 Year parts limited warranty



#### UNIT PERFORMANCE DATA

Model Number *	Nominal Tons	COOLING			HEATING		Unit Dimensions H X W X L	Unit Weight
		Rated Capacity BTUH	SEER		Capacity (BTUH)	HSPF		
			Belt Drive	Direct Drive				
PHS036*0A00AAA	3	35,600	10.20	10.00	34,400	6.7	33-5/16" x 73-11/16" x 45"	500
PHS048*0A00AAA	4	46,500	10.00	9.70	46,500	7.0	33-5/16" x 73-11/16" x 45"	520
PHS060*0A00AAA	5	57,000	10.00	9.90	57,000	7.5	33-5/16" x 73-11/16" x 45"	550

\* Indicates Unit voltage: H = 208/230v (3 Phase), L = 460v (3 Phase)

**NOTE:** Base model numbers listed. See model nomenclature listing for additional options

## TABLE OF CONTENTS

Model Nomenclature .....	2
Features/Benefits .....	3
ARI Capacity Ratings .....	4
Options and Accessories .....	5-7
Electric Heat Capacities .....	8
<b>PHS036-060</b>	
Physical Data .....	9
Base Unit Dimensions .....	10
Performance Data .....	11-20
Electrical Data .....	21-24
Typical Wiring Schematics .....	25-27
Typical Piping and Wiring .....	28
Guide Specifications .....	29-30
Sequence of Operation .....	31

## MODEL NOMENCLATURE

<b>MODEL SERIES</b>	<b>PHS</b>	<b>036</b>	<b>H</b>	<b>0</b>	<b>A</b>	<b>00</b>	<b>A</b>	<b>A</b>	<b>A</b>
PHS = Package Heat Pump, ASHRAE Efficiency									
036 = 36,000		<b>NOMINAL COOLING BTU/h</b>							
048 = 48,000									
060 = 60,000									
072 = 72,000									
090 = 90,000									
102 = 102,000									
120 = 120,000									
150 = 150,000									
180 = 180,000									
H = 208/230-3-60									
L = 460-3-60				<b>VOLTAGE</b>					
0 = No Heat									
A = Standard Motor									
B = High Static Motor					<b>MOTOR OPTION</b>				
00 = No Factory Installed Options									
0A - 0S = See FIOP selection guide for details						<b>FACTORY INSTALLED OPTIONS</b>			
A = Aluminum/Copper Outdoor Coil									
B = Copper/Copper Outdoor Coil							<b>OUTDOOR COIL OPTION</b>		
Sales Model Digit									
Engineering Digit									

## FEATURES/BENEFITS

Every compact one-piece unit arrives fully assembled, charged, tested, and ready to run.

**QUIET, EFFICIENT OPERATION AND DEPENDABLE PERFORMANCE** — Compressors have vibration isolators for quiet operation. Efficient fan and motor design permits operation at low sound levels.

Quiet and efficient operation is provided by belt-driven indoor fans (alternate and high static units). The belt-driven indoor fan is equipped with variable-pitch pulleys which allow adjustment within the rpm ranges of the factory-supplied pulleys. Increased operating efficiency is achieved through computer-designed coils featuring staggered internally enhanced copper tubes. Fins are ripple-edged for strength, lanced, and double waved for higher heat transfer.

**DURABLE, DEPENDABLE CONSTRUCTION** — Designed for durability in any climate, the weather-resistant cabinets are constructed of galvanized steel and bonderized, and all exterior panels are coated with a prepainted baked enamel finish. The paint finish is non-chalking, and is capable of withstanding ASTM (American Society for Testing and Materials) B117 500-hour Salt Spray Test. All internal cabinet panels are primed, permitting longer life and a more attractive appearance for the entire unit.

Totally enclosed outdoor-fan motors and permanently lubricated bearings provide additional unit dependability.

**Patented State-of-the-Art Defrost System** uses time and temperature to keep the outdoor coil frost-free for economical, dependable operation. The defrost board can be easily configured for defrost cycles every 30, 50, or 90 minutes.

**Dependable 4-Way Valve Operation** safely and efficiently accomplishes cycle reversals, defrost, and normal operation.

### **EASY INSTALLATION AND CONVERSION**

**All Units are Shipped in the Vertical Duct Configuration** for fit-up to standard roof curbs. (one curb size fits sizes 036-060.) The contractor can order and install the roof curb early in the construction stage, before decisions on size requirements are made.

All units feature a base rail design with forklift slots and rigging holes for easier maneuvering. Durable packaging protects all units during shipment and storage.

The units can be easily converted from a vertical to a horizontal duct configuration by relocating the panels supplied with the unit.

**To Convert 036-060 Units** from vertical to horizontal discharge, simply relocate 2 panels. The same basic unit can be used for a variety of applications and can be quickly modified at the jobsite.

**NOTE:** On units using horizontal supply and return, the accessory barometric relief or power exhaust **MUST** be installed on the return ductwork. Thru-the-bottom service connection capability comes standard with the rooftop unit to allow power and control wiring to be routed through the unit's basepan, thereby minimizing roof penetrations (to prevent water leaks). Power and control connections are made on the same side of the unit to simplify installation.

**The Non-Corrosive Sloped Condensate Drain Pan** permits either an external horizontal side condensate drain (outside the roof curb) or an internal vertical bottom drain (inside the roof curb). Both options require an external, field-supplied P-trap.

**Standard 2-in. Throwaway Filters** are easily accessed through a removable panel located above the air intake hood. No tools are required to change unit filters.

**All 036-060 Units are Designed With a Single, Continuous Top Piece** to eliminate leaking at the seams or gasketing.

**Field-Installed Accessory Electric heaters** are available in a wide range of capacities. An available single-point wiring kit makes installation simple.

**Low Voltage Wiring Connections** are easily made due to the large terminal board which is located for quick, convenient access. In addition, color-coded wires permit easy tracing and diagnostics.

### **PROVEN COMPRESSOR RELIABILITY**

Design techniques feature computer-programmed balance between compressor, condenser, and evaporator. Hermetic compressors are equipped with compressor overcurrent and overtemperature protection to ensure dependability.

All units have a fixed orifice metering device which precisely controls refrigerant flow, preventing slugging and flood-back, while maintaining optimum unit performance. Refrigerant filter driers are standard.

**Standard Low Ambient Cooling Operation to 25°F;** optional head pressure control kit available for outdoor ambient conditions to -20°F.

### **INTEGRATED ECONOMIZERS AND OUTDOOR-AIR DAMPERS**

Available as options or accessories, economizers and manual outdoor-air dampers introduce outdoor air which mixes with the conditioned air, improving indoor-air quality and often reducing energy consumption.

During a first stage call for cooling, if the outdoor-air temperature is below the economizer control changeover set point, the mixed-air sensor modulates the economizer outdoor-air damper open to take advantage of free cooling provided by the outside air. When second-stage cooling is called for, the compressor is energized in addition to the economizer. If the outdoor-air temperature is above the changeover set point, the first stage of compression is activated and the economizer damper stays at minimum position.

All economizers incorporate a parallel blade, gear driven damper system for efficient air mixing and reliable control.

In addition, the standard damper actuator includes a spring return to provide reliable closure on power loss. The economizers for sizes 036-060 are equipped with up to 100% barometric relief capability for high outdoor airflow operations. Economizers are available, factory-installed, for vertical return only.

In addition, single-stage power exhaust is available as a field-installed accessory for economizer to help maintain proper building pressure.

For units without economizer, year-round ventilation is enhanced by a manual outdoor-air damper. Manual damper is available as a field-installed accessory.

### **INDOOR-AIR QUALITY**

Sloped condensate pans minimize biological growth in rooftop units in accordance with ASHRAE Standard 62. Two-inch filters with optional dirty filter indicator switch provide for greater particle reduction in the return air. The face-split evaporator coils improve the dehumidification capability of standard units, maximize building humidity control.

## ARI CAPACITY RATINGS - PHS036-060

UNIT PHH	NOMINAL TONS	COOLING			HEATING (High Temp)		SOUND RATING (decibels)
		Net Cap. (Btuh)	SEER	SEER	Cap. (Btuh)	HSPF†	
			Belt Drive	Direct Drive			
036	3	35,600	10.2	10.0	34,400	6.7	84
048	4	46,500	10.0	9.70	46,500	7.0	80
060	5	57,000	10.0	9.70	57,000	7.5	82

**LEGEND**

**HSPF** — Heating Seasonal Performance Factor

**SEER** — Seasonal Energy Efficiency Ratio

**NOTES:**

1. Rated in accordance with ARI Standards 210/240-95 and 270-95.
2. Ratings are net values, reflecting the effects of circulating fan heat.
3. ALL the PHS036-060 units are in compliance with ASHRAE 90.1 2001 Energy Standard for minimum SEER and EER requirements. Refer to state and local codes or visit the following website:  
<http://solstice.crest.org/efficiency/bcap> to determine if compliance with this standard pertains to a given geographical area of the United States.
4. Ratings are based on:

**Cooling Standard:** 80°F db, 67°F wb indoor entering-air temperature and 95°F db air entering outdoor unit.

**IPLV Standard:** 80°F db, 67°F wb indoor entering-air temperature and 80°F db outdoor entering-air temperature.

**High-Temp Heating Standard:** 70°F db indoor entering-air temperature and 47°F db, 43°F wb outdoor entering-air temperature.

**Low-Temp Heating Standard:** 70°F db indoor entering-air temperature and 17°F db, 15°F wb outdoor entering-air temperature.

**OPTIONS AND ACCESSORIES - PHS 036-060**

<b>ITEM</b>	<b>OPTION*</b>	<b>ACCESSORY†</b>
Alternate Motors and Drives	X	X
Convenience Outlet (Load Side)	X	
Copper Fins Outdoor Coil	X	
Economizer with Controller	X	X
Electric Heat		X
Electronic Programmable Thermostat**		X
Hinged Filter Door for Economizer		X
Indoor Air Quality (CO <sub>2</sub> ) Sensor (For Return Air)		X
Manual Outdoor–Air Damper	X	
Low Ambient Kits		X
Outdoor Air Enthalpy Sensor		X
Outdoor Coil Grille		X
Outdoor Coil Hail Guard Assembly		X
Outdoor Air/Return Air Temperature Sensor		X
Power Exhaust with Barometric Relief		X
Return Air Enthalpy Sensor		X
Return Air Temperature Sensor		X
Roof Curbs (Vertical and Horizontal Discharge)		X
Smoke Detector Return		X
Smoke Detector Supply	X	
Smoke Detector Supply and Return		X
Thermostats and Subbases**		X
Thru–the–Bottom Utility Connections		X
Compressor Cycle Delay		X
Unit–Mounted Non–Fused Disconnect	X	

\*Factory-installed.

†Field-installed.

\*\* Available thru Fast Parts

**NOTES:**

1. Refer to unit guide specifications or contact your local representative for accessory and option package information.
2. Some options may increase product lead times.

**Roof Curbs (Horizontal and Vertical)** permit installation and securing of ductwork to curb prior to mounting unit on the curb. Both 14-in. and 24-in. roof curbs are available as field-installed accessories.

**Economizer** is available as a factory-installed option in vertical supply/return configuration. (Economizer is available as a field-installed accessory for horizontal and/or vertical supply return configurations.) The Economizer is provided with an industry standard, standalone, solid-state controller that is easy to configure and troubleshoot. The Economizer is compatible with non-DDC applications. Economizer is equipped with a barometric relief damper capable of relieving up to 100% return air. Dry bulb outdoor-air temperature sensor is provided as standard. The return air sensor, indoor enthalpy sensor, and outdoor enthalpy sensor are provided as field-installed accessories to provide enthalpy control, differential enthalpy control, and differential dry bulb temperature control.

**Manual Outdoor-Air Damper** accessory can be preset to admit up to 50% outdoor air for year round ventilation.

**Low Ambient Control** accessory package maintains condensing temperature between 90°F and 110°F at outdoor ambient temperatures down to –20°F by condenser-fan speed modulation or condenser-fan cycling and wind baffles.

**Electric Resistance Heaters** are UL listed and available to match heating requirements. Single point kits available for each heater when required. Heaters are field-installed accessories.

**Unit-Mounted, Non-Fused Disconnect Switch** provides unit power shutoff. The switch is accessible from outside the unit and

provides power off lockout capability and is available as factory-installed option.

**Convenience Outlet** is factory-installed and internally mounted with easily accessible 115-v female receptacle.

**Compressor Cycle Delay** prevents unit from restarting for minimum of 5 minutes after shutdown.

**Thru-the-Bottom Utility Connectors** permit electrical connections to be brought to the unit through the basepan. Connectors are a field-installed accessory.

**Power Exhaust** accessory will provide system exhaust of up to 100% of return air (vertical only). The power exhaust is a field-installed accessory (separate vertical and horizontal design).

**OPTIONS AND ACCESSORIES (cont)**

**ECONOMIZER CONTROL**

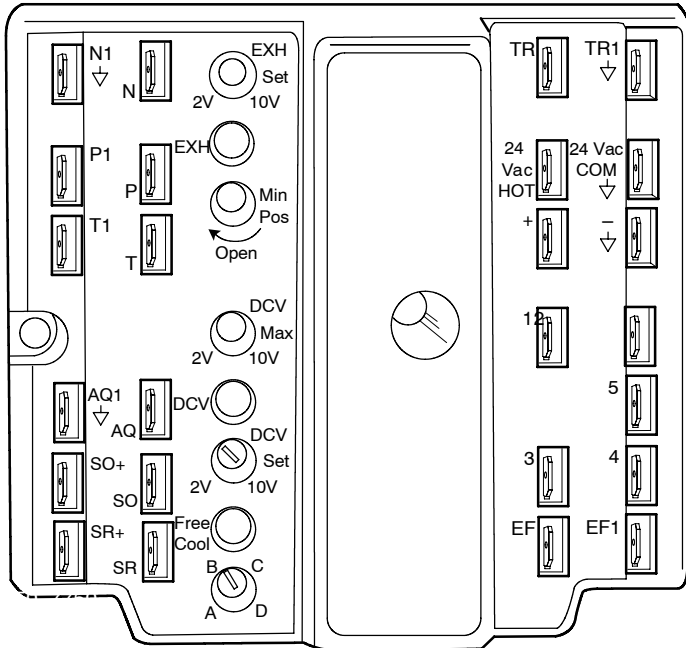

**GEAR-DRIVEN ECONOMIZER COMPONENT PARTS (3 to 5 Ton Unit Shown)**

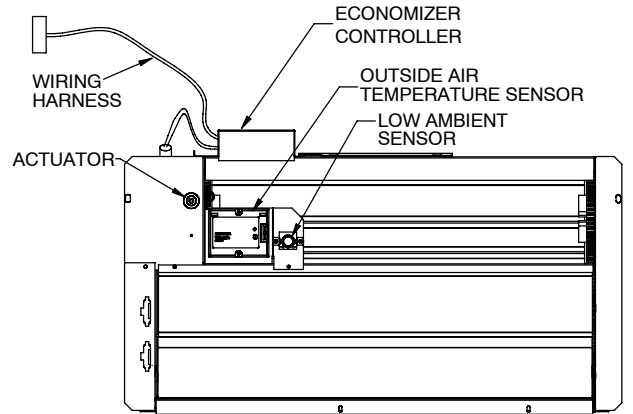

**UNIT-MOUNTED DISCONNECT (Sizes 036-060)**

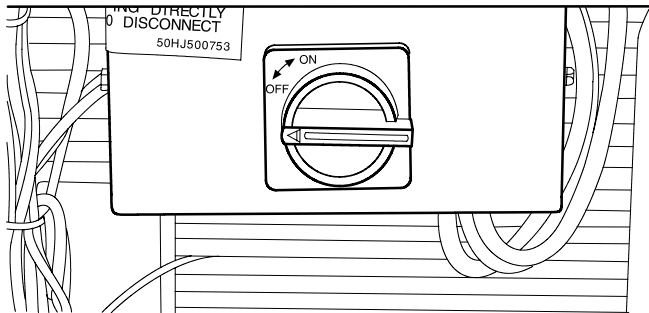
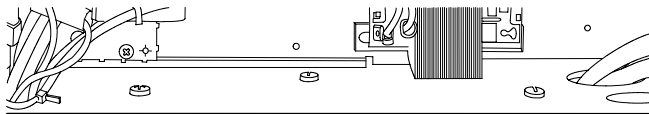

**CONVENIENCE OUTLET**

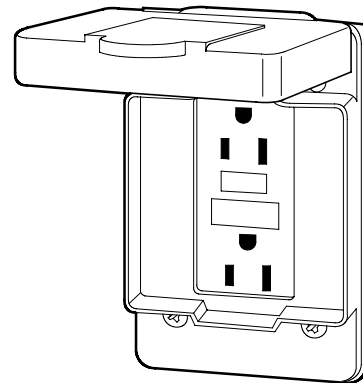

## ACCESSORIES - PHS036-060

### FLAT ROOF CURBS

Model Number	Height	Use With Model Size
DNRFCURB101A01	14"	ALL
DNRFCURB102A01	24"	ALL

### ECONOMIZERS

Model Number	Description	Use With Model Size
DNECOMZR020A02	Vertical - with W7212 controller	ALL
DNECOMZR024A02	Horizontal - with W7212 controller	ALL

### HINGED PANELS - FOR USE WITH ECONOMIZERS (FILTER & COMPRESSOR ACCESS)

Model Number	Description	Use With Model Size
DNHNGPNL001A00	Horizontal Economizers	ALL
DNHNGPNL003A00	Vertical Economizers	ALL

### POWER EXHAUST

Model Number	Description	Use With Model Size
DNPWREXH021A01	460-3-60, Vertical	ALL
DNPWREXH028A01	208/230-3-60, Horizontal	ALL
DNPWREXH029A01	460-3-60, Horizontal	ALL
DNPWREXH030A01	208/230-3-60, Vertical	ALL

### MANUAL OUTDOOR AIR DAMPERS

Model Number	Description	Use With Model Size
DNMANDPR001A02	50% Open	ALL

### PHASE MONITOR CONTROL

Model Number	Description	Use With Model Size
DNPHASE3001A01	Electronic phase monitor breaks "R" control signal if trouble is detected	ALL

### THROUGH-THE-BOTTOM/CURB POWER CONNECTION

Model Number	Description	Use With Model Size
DNBTMPWR001A01	Thru-the bottom electrical + thru-the curb Gas	ALL
DNBTMPWR003A01	Thru-the bottom electrical and Gas	ALL

### SMOKE DETECTORS

Model Number	Description	Use With Model Size
DNSMKDET001D00	Return Airstream Sensor	ALL
DNSMKSUP001B00	Supply Airstream Sensor	ALL
DNSMKSEN001A00	Both Return & Supply Sensors	ALL

### ECONOMIZER SENSORS

Model Number	Description	Use With Model Size
DNTEMPSN001A00	Outdoor Air Temperature (dry bulb) Sensor	ALL Economizers With W7212 Controller
DNTEMPSN002A00	Single or Differential Temp' (dry bulb) Control	ALL Economizers With W7212 Controller
DNCBDIOX005A00	CO <sub>2</sub> Sensor	ALL Economizers With W7212 Controller
DNENTDIF004A00	Return Air Enthalpy Sensor	ALL Economizers With W7212 Controller

### ANTI-CYCLE TIMER

Model Number	Description	Use With Model Size
DNTIMEGD001A00	Five minute compressor delay	ALL

**ACCESSORIES - PHS036-060**

<b>ELECTRIC HEATERS</b>				
<b>UNIT PHS</b>	<b>VOLTAGE</b>	<b>ACCESSORY kW</b>	<b>ACCESSORY HEATER PART NUMBER</b>	<b>SINGLE POINT BOX PACKAGE NO.</b>
<b>036</b>	208/230/240 (3 phase)	3.3/ 4.0/ 4.4 4.9/ 6.0/ 6.5 6.5/ 8.0/ 8.7 7.9/ 9.6/ 10.5 12.0/ 14.7/ 16.0	AES001EHA AES002EHA AES003EHA AES009EHA AES015EHA	- - - - AXB002SPA
	460/480 (3 phase)	5.5/ 6.0 8.1/ 8.8 10.6/ 11.5 12.9/ 14.0	AES006ELA AES008ELA AES011ELA AES013ELA	- - - -
<b>048</b>	208/230/240 (3 phase)	4.9/ 6.0/ 6.5 6.5/ 8.0/ 8.7 12.0/ 14.7/ 16.0 15.8/ 19.3/ 21.0*	AES007EHA AES003EHA AES015EHA AES009EHA+AES009EHA	- - AXB002SPA AXB003SPA
	460/480 (3 phase)	5.5/ 6.0 10.6/ 11.5 12.9/ 14.0 21.1/ 23.0*	AES006ELA AES011ELA AES013ELA AES011ELA+AES011ELA	- - - -
<b>060</b>	208/230/240 (3 phase)	4.9/ 6.0/ 6.5 7.9/ 9.6/ 10.5 12.0/ 14.7/ 16.0 15.8/ 19.3/ 21.0* 19.9/ 24.3/ 26.5*	AES007EHA AES009EHA AES015EHA AES009EHA+AES009EHA AES009EHA+AES015EHA	- -†† AXB002SPA AXB003SPA AXB003SPA
	460/480 (3 phase)	5.5/ 6.0 10.6/ 11.5 12.9/ 14.0 21.1/ 23.0* 23.4/ 25.5*	AES006ELA AES011ELA AES013ELA AES011EL+AAES011ELA AES011ELA+AES013ELA	- - - - -

\* Two heater packages required to provide KW indicated.

††Use AXB002SPA for units with convenience outlet.



## PHYSICAL DATA - PHS036-060

UNIT SIZE	036	048	060
NOMINAL CAPACITY (tons)	3	4	5
<b>OPERATING WEIGHT (lb)</b>			
Unit	500	520	550
Economizer	50	50	50
Roof Curb*	115	115	115
<b>COMPRESSOR</b>			
	Hermetic		
Quantity	1	1	1
Oil (oz)	45	54	50
<b>REFRIGERANT TYPE</b>			
	R22		
Operating Charge (lb-oz)			
Circuit 1	5-1	6-0	8-0
Circuit 2	—	—	—
<b>OUTDOOR COIL</b>			
	3/8-in. OD Enhanced Copper Tubes, Aluminum Lanced Fins, Fixed Orifice Metering Device		
Rows...Fins/in.	1...17	1...17	2...17
Total Face Area (sq ft)	10.31	14.58	12.25
<b>OUTDOOR FAN</b>			
	Propeller Type		
Nominal Cfm	4000	4000	4000
Quantity...Diameter (in.)	1...22.0	1...22.0	1...22.0
Motor Hp...Rpm	1/4...1100	1/4...1100	1/4...1100
Watts Input (Total)	325	325	325
<b>INDOOR COIL</b>			
	3/8-in. OD Enhanced Copper Tubes, Aluminum Double-Wavy Fins, Fixed Orifice Metering Device		
Rows...Fins/in.	2...15	2...15	3...15
Total Face Area (sq ft)	4.2	4.2	5.5
<b>INDOOR FAN</b>			
	Centrifugal Type		
Quantity...Size (in.)	Std 1...10 x 10 High-Static	1...10 x 10 1...10 x 10	1...11 x 10 1...10 x 10
Type Drive	Std Direct High-Static	Direct Belt	Direct Belt
Nominal Cfm	1200	1600	2000
Maximum Continuous Bhp	Std .34 High-Static	.75 2.40	1.20 2.90
Motor Frame Size	Std 48 High-Static	48 56	48 56
Nominal Rpm High/Low	Std 860/800 High-Static	1075/970 1725	1075/970 1725
Fan Rpm Range	Std — High-Static	—	—
Motor Bearing Type	1075-1455 Ball	1075-1455 Ball	1300-1685 Ball
Maximum Allowable Rpm	2100	2100	2100
Motor Pulley Pitch Diameter Min/Max (in.)	Std — High-Static	—	—
Nominal Motor Shaft Diameter (in.)	Std 2.8/3.8 High-Static	2.8/3.8	3.4/4.4
Fan Pulley Pitch Diameter (in.)	Std 1/2 High-Static	1/2 5/8	1/2 5/8
Belt, Quantity...Type...Length (in.)	Std — High-Static	—	—
Pulley Center Line Distance (in.)	Std 10.0-12.4 High-Static	10.0-12.4	14.7-15.5
Speed Change per Full Turn of Movable Pulley Flange (rpm)	Std 65 High-Static	65	60
Movable Pulley Maximum Full Turns From Closed Position	Std — High-Static	—	—
Factory Setting	Std 6 High-Static	6	5
Factory Speed Setting (rpm)	Std — High-Static	—	—
Fan Shaft Diameter at Pulley (in.)	Std 3 1/2 High-Static	3 1/2	3 1/2
	856 5/8	932 5/8	1035 5/8
<b>HIGH-PRESSURE SWITCH (psig)</b>			
Standard Compressor Internal Relief (Differential)		450 ± 50	
Cutout		428	
Reset (Auto.)		320	
<b>LOSS-OF-CHARGE SWITCH (psig)</b>			
Cutout		7 ± 3	
Reset (Auto.)		22 ± 7	
<b>FREEZE-PROTECTION THERMOSTAT (F)</b>			
Opens		30 ± 5	
Closes		45 ± 5	
<b>OUTDOOR-AIR INLET SCREENS</b>			
	Cleanable. Quantity and size depend on options selected.		
<b>RETURN-AIR FILTERS</b>			
	Throwaway		
Quantity...Size (in.)	2...16 x 25 x 2		

**LEGEND:** Bhp — Brake Horsepower, \*Weight of 14-in. roof curb, †Three phase.

**NOTE:** The PHS units have a loss-of-charge switch located in the liquid line.

# Base Unit Dimensions - PHS036-060

CONNECTION SIZES	
A	1 3/8" DIA. [351] FIELD POWER SUPPLY HOLE
B	2" DIA. [513] POWER SUPPLY KNOCK-OUT
C	1 3/4" DIA. [441] CHARGING PORT HOLE
D	7/8" DIA. [221] FIELD CONTROL WIRING HOLE
E	3/4" - 1/4 NPT CONDENSATE DRAIN
F	2 1/2" DIA. [641] POWER SUPPLY KNOCK-OUT

BOTTOM POWER CHART, THESE UNITS ARE PROVIDED WITH NECESSARY PACKAGES - DN1PHR001A01	
THREADED WIRE CONDUIT SIZE	REQ'D HOLE USE SIZES (MAX.)
1/2"	7/8" [22.2]
3/4"	1 1/8" [28.6]
1"	1 3/8" [34.9]
1 1/2"	2 1/8" [57.1]
2"	3 1/8" [82.5]

PHS	STD UNIT WEIGHT		ECONOMIZER WEIGHT		VERT. ECON. W/P.P.E. WEIGHT		CORNER WEIGHT (A)		CORNER WEIGHT (B)		CORNER WEIGHT (C)		CORNER WEIGHT (D)	
	LB	KG	LB	KG	LB	KG	LB	KG	LB	KG	LB	KG	LB	KG
036	500	227	50	22.7	90	40.9	123	57	120	54	125	57	130	59
048	520	236	50	22.7	90	40.9	130	59	125	57	130	59	135	61
060	550	249	50	22.7	90	40.9	138	63	132	60	138	62	142	64

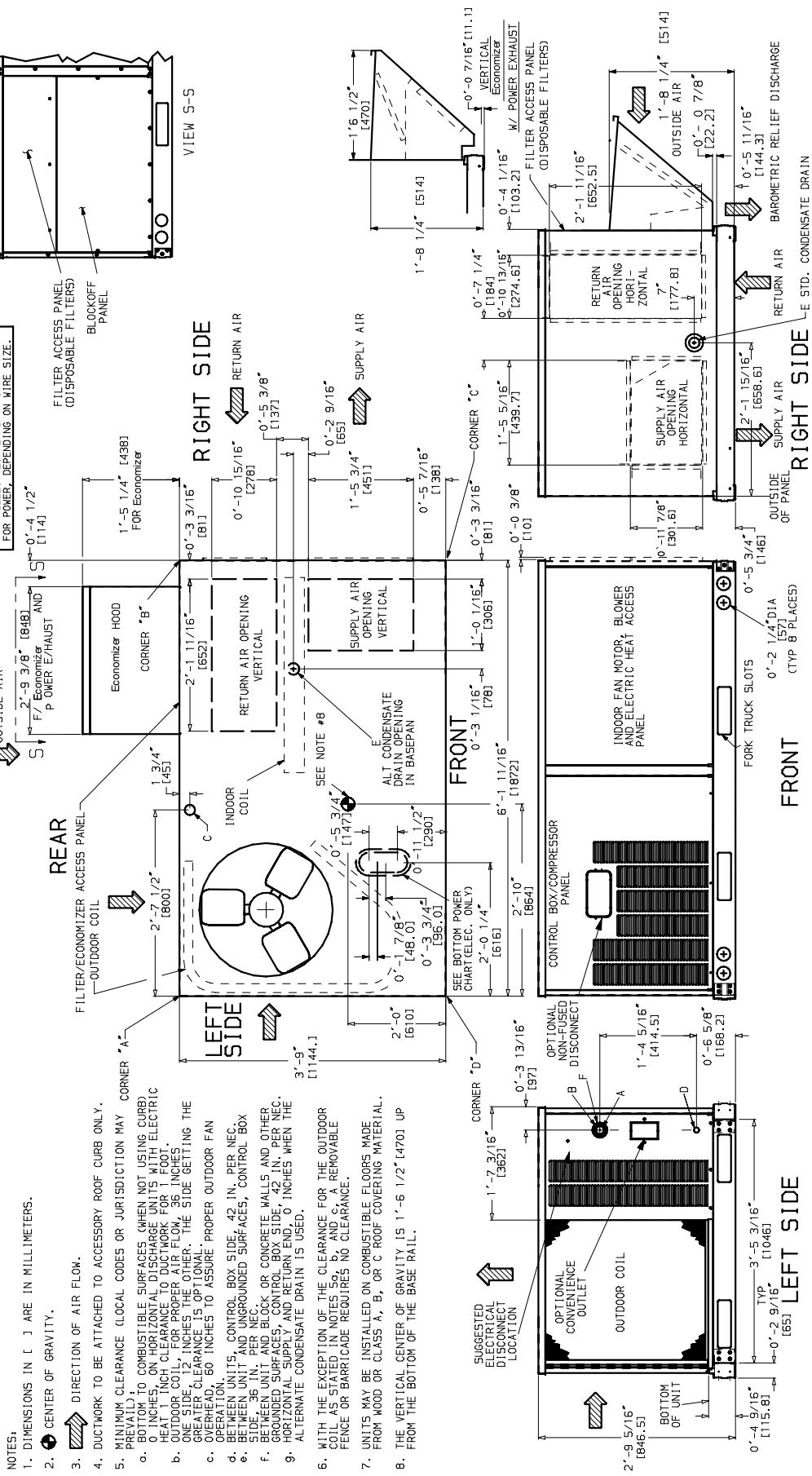

- NOTES:**
- DIMENSIONS IN [ ] ARE IN MILLIMETERS.
  - CENTER OF GRAVITY.
  - DIRECTION OF AIR FLOW.
  - DUCTWORK TO BE ATTACHED TO ACCESSORY ROOF CURB ONLY.
  - MINIMUM CLEARANCE (LOCAL CODES OR JURISDICTION MAY PREVAIL).
    - BOTTOM TO COMBUSTIBLE SURFACES (WHEN NOT USING CURB). INCHES. MINIMUM CLEARANCE UNDER UNIT TO FLAT ELECTRIC HEAT EXCHANGER OR DISCHARGE UNIT IS 36 INCHES.
    - INDOOR COIL - FOR PROPER AIR FLOW, 36 INCHES. ONE SIDE, 12 INCHES THE OTHER. THE SIDE GETTING THE GREATER CLEARANCE IS OPTIONAL.
    - OVERHEAD, 60 INCHES TO ASSURE PROPER OUTDOOR FAN OPERATION.
    - BETWEEN UNITS AND UNGROUND SURFACES, CONTROL BOX SIDE IS 36 IN. PER NEC.
    - BETWEEN UNITS AND BLOCK OR CONCRETE WALLS AND OTHER GROUNDED SURFACES, CONTROL BOX SIDE, 42 IN. PER NEC.
    - HORIZONTAL SUPPLY AND RETURN END, 0 INCHES WHEN THE ALTERNATE CONDENSATE DRAIN IS USED.
  - WITH THE EXCEPTION OF THE CLEARANCE FOR THE OUTDOOR COIL AS STATED IN NOTES 5 AND 6, ALL CLEARANCES ARE NON-REMOVABLE FENCE OR BARRICADE REQUIRES NO CLEARANCE.
  - UNITS MAY BE INSTALLED ON COMBUSTIBLE FLOORS MADE FROM WOOD OR CLASS A, B, OR C ROOF COVERING MATERIAL.
  - THE VERTICAL CENTER OF GRAVITY IS 1'-6 1/2" [470] UP FROM THE BOTTOM OF THE BASE RAIL.

**PERFORMANCE DATA - PHS036-060**

**COOLING CAPACITIES**

PHS036 (3 TONS)										
Temp (F) Outdoor Entering Air (Edb)		Indoor Entering Air — Cfm/BF								
		900/0.10			1200/0.15			1500/0.21		
		Indoor Entering Air — Ewb (F)								
		72	67	62	72	67	62	72	67	62
75	TC	42.4	39.9	36.5	43.0	41.2	38.7	45.1	42.8	40.3
	SHC	16.7	22.0	26.8	17.5	24.2	30.9	19.3	26.9	34.1
	kW	2.77	2.71	2.62	2.78	2.74	2.68	2.85	2.79	2.73
85	TC	41.5	38.4	34.8	43.3	40.4	37.0	44.0	41.7	38.7
	SHC	16.6	21.6	26.2	18.2	24.6	30.3	19.3	27.2	33.7
	kW	3.01	2.92	2.80	3.07	2.98	2.88	3.09	3.03	2.94
95	TC	40.0	36.3	33.0	42.3	38.5	35.2	43.4	40.0	36.7
	SHC	16.2	20.9	25.7	18.2	24.2	29.8	19.7	27.2	32.7
	kW	3.24	3.10	2.99	3.32	3.19	3.07	3.36	3.24	3.13
105	TC	38.4	34.7	31.0	40.0	36.7	33.1	41.2	37.7	35.2
	SHC	15.7	20.5	24.8	17.5	23.9	28.8	19.3	26.6	31.7
	kW	3.47	3.32	3.16	3.53	3.41	3.26	3.58	3.44	3.35
115	TC	36.1	32.5	28.9	38.1	34.3	31.1	39.3	35.5	33.2
	SHC	15.1	19.8	23.9	17.2	23.2	27.8	19.1	26.2	30.2
	kW	3.66	3.50	3.32	3.76	3.59	3.44	3.81	3.65	3.54
125	TC	34.2	30.5	26.8	35.9	32.0	29.3	36.8	33.0	31.3
	SHC	14.6	19.2	22.9	16.7	22.6	26.3	18.5	25.5	28.4
	kW	3.88	3.68	3.49	3.97	3.77	3.62	4.02	3.83	3.74

PHS048 (4 TONS)										
Temp (F) Outdoor Entering Air (Edb)		Indoor Entering Air — Cfm/BF								
		1200/0.11			1600/0.15			2000/0.22		
		Indoor Entering Air — Ewb (F)								
		72	67	62	72	67	62	72	67	62
75	TC	55.5	51.9	47.4	56.9	54.6	50.3	59.3	56.5	52.1
	SHC	24.5	31.2	37.4	26.0	35.2	43.4	28.4	39.0	47.6
	kW	3.80	3.70	3.55	3.84	3.79	3.66	3.93	3.86	3.71
85	TC	53.4	49.7	45.3	56.3	52.6	47.8	57.5	54.1	49.8
	SHC	23.8	30.4	36.7	26.3	34.9	42.6	28.3	38.6	46.9
	kW	4.10	3.99	3.84	4.23	4.11	3.94	4.27	4.16	4.01
95	TC	52.0	47.4	43.0	53.7	49.9	45.5	54.5	51.6	47.4
	SHC	23.4	29.6	35.8	25.5	33.9	41.6	27.3	38.2	45.2
	kW	4.47	4.28	4.11	4.53	4.39	4.23	4.56	4.48	4.29
105	TC	49.3	45.0	40.6	51.8	47.2	43.0	52.6	48.7	45.4
	SHC	22.5	28.8	34.7	25.3	33.0	40.3	27.1	37.1	43.3
	kW	4.77	4.59	4.39	4.90	4.68	4.52	4.92	4.76	4.63
115	TC	46.6	42.4	38.0	48.8	44.6	40.6	50.2	45.8	43.2
	SHC	21.7	27.9	33.6	24.3	32.4	38.7	26.8	36.1	41.2
	kW	5.08	4.90	4.66	5.21	5.01	4.81	5.29	5.06	4.96
125	TC	44.0	39.6	35.4	45.6	41.6	38.3	47.0	42.9	40.9
	SHC	20.9	26.9	32.4	23.3	31.6	36.5	25.9	35.6	39.0
	kW	5.45	5.21	4.96	5.51	5.34	5.14	5.60	5.41	5.30

**PERFORMANCE DATA - PHS036-060 (cont.)**

**COOLING CAPACITIES**

Temp (F) Outdoor Entering Air (Edb)		Indoor Entering Air — Cfm/BF								
		1500/0.05			2000/0.08			2500/0.14		
		Indoor Entering Air — Ewb (F)								
		72	67	62	72	67	62	72	67	62
75	TC	69.3	64.5	59.3	70.8	67.9	62.8	72.9	69.3	65.4
	SHC	30.9	39.2	47.4	33.1	44.9	55.4	35.8	49.4	61.4
	kW	4.28	4.15	4.03	4.32	4.25	4.12	4.38	4.29	4.19
85	TC	67.7	62.4	56.8	69.1	65.7	60.2	71.1	67.7	63.2
	SHC	30.4	38.6	46.5	32.8	44.6	54.4	35.8	50.0	59.8
	kW	4.76	4.61	4.49	4.79	4.72	4.56	4.86	4.78	4.65
95	TC	65.2	59.8	54.4	67.7	62.9	57.6	69.1	64.8	60.7
	SHC	29.6	37.6	45.5	32.8	43.6	53.2	35.6	49.3	57.7
	kW	5.27	5.10	4.97	5.35	5.20	5.07	5.39	5.27	5.14
105	TC	62.3	57.2	51.8	65.1	59.6	54.9	66.8	61.7	58.3
	SHC	28.6	33.8	44.4	32.1	42.6	51.6	35.4	48.2	55.5
	kW	5.79	5.66	5.50	5.90	5.73	5.61	5.97	5.79	5.68
115	TC	59.7	54.2	49.0	61.7	57.0	52.5	63.2	58.4	55.8
	SHC	27.6	35.8	43.2	31.1	41.9	49.6	34.3	47.0	53.2
	kW	6.37	6.24	6.06	6.47	6.34	6.20	6.53	6.36	6.31
125	TC	56.5	51.0	46.0	58.2	53.5	49.8	59.4	55.1	53.0
	SHC	26.8	34.7	41.9	30.0	40.8	47.3	33.0	46.5	50.5
	kW	7.03	6.87	6.65	7.07	6.96	6.82	7.13	7.03	6.96

**LEGEND**

- |  |   |
|--|---|
| <b>BF</b> — Bypass Factor                    | <b>Ldb</b> — Leaving Dry-Bulb                         |
| <b>Edb</b> — Entering Dry-Bulb               | <b>Lwb</b> — Leaving Wet-Bulb                         |
| <b>Ewb</b> — Entering Wet-Bulb               | <b>SHC</b> — Sensible Heat Capacity (1000 Btuh) Gross |
| <b>kW</b> — Compressor Motor Power Input     |   |
| <b>TC</b> — Total Capacity (1000 Btuh) Gross |   |

**NOTES:**

1. Direct interpolation is permissible. Do not extrapolate.
2. The following formulas may be used:

$$t_{ldb} = t_{edb} - \frac{\text{sensible capacity (Btuh)}}{1.10 \times \text{cfm}}$$

$$t_{lwb} = \text{Wet-bulb temperature corresponding to enthalpy of air leaving indoor coil (} h_{lwb} \text{) total capacity (Btuh)} / h_{lwb} = h_{ewb} - 4.5 \times \text{cfm}$$

Where:  $h_{ewb}$  = Enthalpy of air entering evaporator coil

3. The SHC is based on 80°F edb temperature of air entering indoor coil. Below 80°F edb, subtract (corr factor x cfm) from SHC. Above 80°F edb, add (corr factor x cfm) to SHC.

**INSTANTANEOUS AND INTEGRATED HEATING RATINGS**

PHS036																			
Return Air (F db)	Cfm (Standard Air)	Air Temperature Entering Outdoor Coil (F)																	
		0		10		17		30		40		47		50		60			
55	900	Cap	15.4	13.1	19.2	17.6	21.7	19.8	27.4	24.0	31.9	31.9	35.3	35.3	36.9	36.9	41.4	41.4	
		kW	2.25		2.44		2.57		2.86		3.10		3.29		3.38		3.64		
	1200	Cap	15.9	13.5	19.4	17.8	22.5	20.5	28.3	24.8	32.9	32.9	35.8	35.8	37.0	37.0	40.1	40.1	
		kW	2.24		2.40		2.54		2.80		3.02		3.15		3.21		3.35		
	1500	Cap	16.2	13.8	19.8	18.2	22.9	20.9	28.8	25.2	33.1	33.1	35.3	35.3	36.5	36.5	38.6	38.6	
		kW	2.23		2.38		2.52		2.76		2.94		3.03		3.08		3.17		
70	900	Cap	13.2	11.2	17.1	15.7	20.0	18.2	25.4	22.2	29.8	29.8	33.2	33.2	34.7	34.7	40.1	40.1	
		kW	2.29		2.50		2.67		2.98		3.24		3.45		3.55		3.91		
	1200	Cap	13.7	11.6	17.7	16.3	20.3	18.5	26.3	23.1	30.8	30.8	34.4	34.4	36.0	36.0	40.9	40.9	
		kW	2.28		2.49		2.62		2.93		3.17		3.36		3.45		3.72		
	1500	Cap	14.0	11.9	18.1	16.6	20.7	18.9	26.9	23.6	31.6	31.6	35.1	35.1	36.9	36.9	40.2	40.2	
		kW	2.27		2.47		2.60		2.89		3.12		3.30		3.38		3.54		
80	900	Cap	11.5	9.8	15.5	14.2	18.4	16.8	23.7	20.8	28.1	28.1	31.7	31.7	33.2	33.2	38.5	38.5	
		kW	2.30		2.54		2.71		3.04		3.32		3.55		3.65		4.03		
	1200	Cap	12.0	10.2	16.2	14.8	19.2	17.5	24.7	21.6	29.3	29.3	33.0	33.0	34.5	34.5	40.2	40.2	
		kW	2.30		2.52		2.69		2.99		3.26		3.47		3.56		3.91		
	1500	Cap	12.3	10.5	16.6	15.2	19.7	18.0	25.4	22.3	30.1	30.1	33.7	33.7	35.3	35.3	39.2	39.2	
		kW	2.29		2.51		2.68		2.97		3.22		3.41		3.50		3.70		

**PERFORMANCE DATA - PHS036-060 (cont.)**

**INSTANTANEOUS AND INTEGRATED HEATING RATINGS**

<b>PHS048</b>																		
Return Air (F db)	Cfm (Standard Air)	Air Temperature Entering Outdoor Coil (F)																
		0		10		17		30		40		47		50		60		
55	1200	Cap	22.7	19.3	26.6	24.4	30.2	27.6	37.4	32.7	43.1	43.1	47.6	47.6	49.8	49.8	57.2	57.2
		kW	2.91		3.14		3.35		3.77		4.12		4.40		4.54		5.04	
	1600	Cap	23.1	19.7	27.2	25.0	30.8	28.1	38.2	33.5	44.1	44.1	48.9	48.9	51.1	51.1	59.0	59.0
		kW	2.87		3.09		3.28		3.66		3.97		4.23		4.34		4.80	
	2000	Cap	23.4	19.9	27.4	25.2	31.2	28.4	38.7	33.9	44.8	44.8	49.7	49.7	52.0	52.0	60.2	60.2
		kW	2.85		3.05		3.23		3.59		3.88		4.11		4.23		4.65	
70	1200	Cap	20.6	17.5	25.5	23.4	28.4	25.9	35.6	31.2	41.0	41.0	45.5	45.5	47.5	47.5	54.9	54.9
		kW	3.00		3.33		3.52		4.01		4.39		4.71		4.85		5.40	
	1600	Cap	21.2	18.0	25.6	23.5	29.1	26.6	36.3	31.8	42.1	42.1	46.8	46.8	48.9	48.9	56.5	56.5
		kW	2.99		3.25		3.47		3.90		4.25		4.54		4.67		5.15	
	2000	Cap	21.6	18.3	25.9	23.8	29.5	26.9	36.9	32.3	42.8	42.8	47.5	47.5	49.7	49.7	57.6	57.6
		kW	2.97		3.22		3.43		3.84		4.16		4.42		4.55		5.00	
80	1200	Cap	18.6	15.8	23.9	21.9	27.1	24.7	34.2	29.9	39.7	39.7	44.1	44.1	46.1	46.1	53.2	53.2
		kW	3.01		3.40		3.62		4.15		4.56		4.90		5.06		5.63	
	1600	Cap	19.4	16.4	24.7	22.6	27.8	25.4	35.1	30.8	40.7	40.7	45.3	45.3	47.3	47.3	54.9	54.9
		kW	3.01		3.37		3.58		4.06		4.43		4.74		4.88		5.39	
	2000	Cap	19.8	16.8	25.1	23.1	28.2	25.7	35.7	31.3	41.5	41.5	46.0	46.0	48.2	48.2	55.8	55.8
		kW	3.01		3.35		3.54		4.00		4.35		4.63		4.76		5.24	

<b>PHS060</b>																		
Return Air (F db)	Cfm (Standard Air)	Air Temperature Entering Outdoor Coil (F)																
		0		10		17		30		40		47		50		60		
55	1500	Cap	29.7	25.2	34.5	31.7	38.4	35.0	46.0	40.3	52.4	52.4	57.2	57.2	59.6	59.6	67.9	67.9
		kW	3.96		4.14		4.30		4.62		4.90		5.14		5.25		5.67	
	2000	Cap	29.8	25.4	34.7	31.8	38.6	35.2	46.3	40.6	52.9	52.9	57.7	57.7	60.1	60.1	68.7	68.7
		kW	3.83		3.98		4.12		4.38		4.63		4.82		4.91		5.25	
	2500	Cap	29.8	25.4	34.8	31.9	38.7	35.3	46.6	40.8	53.1	53.1	58.0	58.0	60.4	60.4	68.4	68.4
		kW	3.76		3.89		4.01		4.26		4.47		4.63		4.72		4.99	
70	1500	Cap	28.7	24.4	33.8	31.0	37.8	34.4	45.4	39.8	51.5	51.5	56.2	56.2	58.4	58.4	66.5	66.5
		kW	4.43		4.66		4.84		5.21		5.53		5.79		5.91		6.39	
	2000	Cap	29.0	24.7	34.0	31.2	38.0	34.7	45.7	40.1	51.9	51.9	56.7	56.7	59.0	59.0	67.4	67.4
		kW	4.30		4.48		4.63		4.94		5.20		5.41		5.52		5.91	
	2500	Cap	29.2	24.8	34.2	31.4	38.2	34.8	45.8	40.2	52.2	52.2	57.1	57.1	59.4	59.4	67.9	67.9
		kW	4.22		4.38		4.51		4.78		5.01		5.21		5.30		5.63	
80	1500	Cap	28.1	23.8	33.1	30.4	37.2	33.9	44.9	39.3	51.0	51.0	55.6	55.6	57.8	57.8	65.7	65.7
		kW	4.77		5.03		5.23		5.64		5.99		6.27		6.41		6.92	
	2000	Cap	28.4	24.2	33.5	30.7	37.6	34.2	45.3	39.7	51.4	51.4	56.1	56.1	58.3	58.3	66.5	66.5
		kW	4.63		4.84		5.01		5.34		5.63		5.86		5.97		6.39	
	2500	Cap	28.6	24.3	33.7	30.9	37.7	34.4	45.5	39.8	51.6	51.6	56.4	56.4	58.7	58.7	67.0	67.0
		kW	4.55		4.73		4.88		5.17		5.42		5.62		5.72		6.09	

**LEGEND**

Cap. — Heating Capacity (1000 Btuh) (includes indoor-fan motor heat)

db — dry bulb

kW — Total Power Input (includes compressor motor power input, outdoor-fan motor input, and indoor-fan motor input)

**NOTES**

1. Shaded areas indicate integrated ratings

2. Integrated capacity is maximum (instantaneous) capacity less the effect of frost on the outdoor coil and the heat required to defrost it.

**PERFORMANCE DATA - PHS036-060 (cont.)**

**FAN PERFORMANCE VERTICAL DISCHARGE UNITS**

PHS036 (3 TONS) — STANDARD MOTOR (DIRECT DRIVE)												
Airflow (Cfm)	Low Speed						High Speed					
	208 v			230, 460, 575 v			208 v			230, 460, 575 v		
	ESP	Bhp	Watts	ESP	Bhp	Watts	ESP	Bhp	Watts	ESP	Bhp	Watts
900	0.67	0.21	253	0.68	0.23	277	0.69	0.26	307	0.69	0.31	363
1000	0.60	0.23	270	0.61	0.25	292	0.61	0.27	321	0.63	0.32	374
1100	0.55	0.24	287	0.56	0.26	307	0.57	0.28	335	0.58	0.33	385
1200	0.51	0.26	304	0.51	0.27	323	0.52	0.29	349	0.53	0.34	397
1300	0.45	0.27	321	0.46	0.29	338	0.46	0.31	364	0.47	0.34	408
1400	0.38	0.29	338	0.41	0.30	354	0.43	0.32	378	—	—	—
1500	0.34	0.30	355	0.36	0.31	369	0.38	0.33	392	—	—	—

**LEGEND**

**Bhp** — Brake Horsepower Input to Fan

**ESP** — External Static Pressure (in. wg)

**Watts** — Input Watts to Motor

See GENERAL FAN PERFORMANCE NOTES following this section.

PHS036 (3 TONS) — HIGH-STATIC MOTOR AND DRIVE* (Belt Drive)															
Airflow (Cfm)	External Static Pressure (in. wg)														
	0.2			0.4			0.6			0.8			1.0		
	Rpm	Bhp	Watts	Rpm	Bhp	Watts	Rpm	Bhp	Watts	Rpm	Bhp	Watts	Rpm	Bhp	Watts
900	643	0.15	152	768	0.22	222	870	0.30	296	958	0.37	373	1037	0.46	454
1000	683	0.19	191	804	0.27	268	904	0.35	348	991	0.43	430	1069	0.52	517
1100	725	0.24	237	842	0.32	321	939	0.41	407	1025	0.50	496	1102	0.59	588
1200	767	0.29	291	880	0.38	382	976	0.48	474	1060	0.57	570	1136	0.67	668
1300	811	0.35	352	920	0.45	451	1013	0.55	550	1095	0.66	652	1170	0.76	756
1400	855	0.43	423	960	0.53	529	1051	0.64	636	1132	0.75	744	1205	0.86	855
1500	900	0.51	504	1002	0.62	617	1090	0.74	731	1169	0.85	846	1242	0.97	963

PHS036 (3 TONS) — HIGH-STATIC MOTOR AND DRIVE* (Belt Drive) (cont)															
Airflow (Cfm)	External Static Pressure (in. wg)														
	1.2			1.4			1.6			1.8			2.0		
	Rpm	Bhp	Watts	Rpm	Bhp	Watts	Rpm	Bhp	Watts	Rpm	Bhp	Watts	Rpm	Bhp	Watts
900	1110	0.54	538	1177	0.63	627	1239	0.72	718	1298	0.82	813	1355	0.92	911
1000	1141	0.61	607	1207	0.70	700	1269	0.80	796	1328	0.90	895	1384	1.00	998
1100	1173	0.69	683	1238	0.79	781	1300	0.89	883	1358	0.99	987	1414	1.10	1094
1200	1205	0.77	768	1270	0.88	872	1332	0.98	979	1389	1.09	1088	1444	1.21	1200
1300	1239	0.87	863	1303	0.98	972	1364	1.09	1084	1421	1.21	1199	<b>1475</b>	<b>1.32</b>	<b>1316</b>
1400	1273	0.97	967	1337	1.09	1082	1397	1.21	1200	1453	1.33	1320	<b>1507</b>	<b>1.45</b>	<b>1443</b>
1500	1309	1.09	1082	1371	1.21	1204	1430	1.33	1327	<b>1486</b>	<b>1.46</b>	<b>1453</b>	<b>1540</b>	<b>1.59</b>	<b>1581</b>

**LEGEND**

**Bhp** — Brake Horsepower Input to Fan

**Watts** — Input Watts to Motor

\*Motor drive range: 1075 to 1455 rpm. All other rpms require a field-supplied drive.

**NOTES**

1. Bold data indicates field-supplied drive is required.

2. Maximum continuous Bhp is 2.40.

3. See GENERAL FAN PERFORMANCE NOTES following this section.

PERFORMANCE DATA - PHS036-060 (cont.)

FAN PERFORMANCE VERTICAL DISCHARGE UNITS

PHS048 (4 TONS) — STANDARD MOTOR (DIRECT DRIVE)												
Airflow (Cfm)	Low Speed						High Speed					
	208 v			230, 460, 575 v			208 v			230, 460, 575 v		
	ESP	Bhp	Watts	ESP	Bhp	Watts	ESP	Bhp	Watts	ESP	Bhp	Watts
1200	0.93	0.41	458	0.94	0.45	506	0.94	0.51	572	0.99	0.56	632
1300	0.86	0.42	471	0.87	0.46	521	0.87	0.52	589	0.92	0.58	651
1400	0.78	0.45	503	0.79	0.49	556	0.79	0.54	616	0.87	0.60	681
1500	0.70	0.47	536	0.73	0.52	593	0.73	0.56	631	0.80	0.62	698
1600	0.61	0.49	557	0.64	0.54	616	0.66	0.58	654	0.76	0.64	723
1700	0.51	0.52	584	0.54	0.57	646	0.58	0.60	678	0.68	0.66	750
1800	0.40	0.54	610	0.44	0.60	674	0.51	0.62	698	0.63	0.68	772
1900	0.29	0.56	629	0.37	0.62	696	0.46	0.64	720	0.56	0.70	796
2000	0.25	0.58	651	0.30	0.64	720	0.39	0.66	744	0.50	0.73	823

PHS048 (4 TONS) — HIGH-STATIC MOTOR AND DRIVE* (Belt Drive)															
Airflow (Cfm)	External Static Pressure (in. wg)														
	0.2			0.4			0.6			0.8			1.0		
	Rpm	Bhp	Watts	Rpm	Bhp	Watts	Rpm	Bhp	Watts	Rpm	Bhp	Watts	Rpm	Bhp	Watts
1200	767	0.29	291	880	0.38	382	976	0.48	474	1060	0.57	570	1136	0.67	668
1300	811	0.35	352	920	0.45	451	1013	0.55	550	1095	0.66	652	1170	0.76	756
1400	855	0.43	423	960	0.53	529	1051	0.64	636	1132	0.75	744	1205	0.86	855
1500	900	0.51	504	1002	0.62	617	1090	0.74	731	1169	0.85	846	1242	0.97	963
1600	945	0.60	594	1044	0.72	716	1130	0.84	837	1207	0.96	959	1278	1.09	1083
1700	991	0.70	696	1086	0.83	825	1170	0.96	954	1246	1.09	1083	1316	1.22	1214
1800	1038	0.81	810	1130	0.95	947	1211	1.09	1083	1286	1.23	1219	1354	1.36	1357
1900	1085	0.94	936	1174	1.09	1081	1253	1.23	1224	1326	1.38	1368	1393	1.52	1513
2000	1132	1.08	1075	1218	1.23	1228	1296	1.39	1379	1367	1.54	1531	1432	1.69	1682

PHS048 (4 TONS) — HIGH-STATIC MOTOR AND DRIVE* (Belt Drive) (cont)															
Airflow (Cfm)	External Static Pressure (in. wg)														
	1.2			1.4			1.6			1.8			2.0		
	Rpm	Bhp	Watts	Rpm	Bhp	Watts	Rpm	Bhp	Watts	Rpm	Bhp	Watts	Rpm	Bhp	Watts
1200	1205	0.77	768	1270	0.88	872	1332	0.98	979	1389	1.09	1088	1444	1.21	1200
1300	1239	0.87	863	1303	0.98	972	1364	1.09	1084	1421	1.21	1199	1475	1.32	1316
1400	1273	0.97	967	1337	1.09	1082	1397	1.21	1200	1453	1.33	1320	1507	1.45	1443
1500	1309	1.09	1082	1371	1.21	1204	1430	1.33	1327	1486	1.46	1453	1540	1.59	1581
1600	1344	1.21	1208	1406	1.34	1336	1465	1.47	1465	1520	1.61	1597	1573	1.74	1731
1700	1381	1.35	1346	1442	1.49	1480	1500	1.62	1616	1555	1.76	1753	1607	1.90	1893
1800	1418	1.50	1496	1478	1.64	1636	1535	1.79	1778	1589	1.93	1922	1641	2.08	2068
1900	1456	1.67	1658	1515	1.82	1806	1571	1.96	1954	1625	2.12	2104	1676	2.27	2256
2000	1494	1.84	1835	1553	2.00	1989	1608	2.16	2144	1661	2.31	2301	—	—	—

LEGEND

Bhp — Brake Horsepower Input to Fan

Watts — Input Watts to Motor

\*Motor drive range: 1075 to 1455 rpm. All other rpms require a field-supplied drive.

NOTES

1. Bold data indicates field-supplied drive is required.

2. Maximum continuous Bhp is 2.40.

3. See GENERAL FAN PERFORMANCE NOTES following this section.

**PERFORMANCE DATA - PHS036-060 (cont.)**

**FAN PERFORMANCE VERTICAL DISCHARGE UNITS**

<b>PHS060 (5 TONS) — STANDARD MOTOR (DIRECT DRIVE)</b>																		
Air-flow (Cfm)	Low Speed						Medium Speed						High Speed					
	208 v			230, 460, 575 v			208 v			230, 460, 575 v			208 v			230, 460, 575 v		
	ESP	Bhp	Watts	ESP	Bhp	Watts	ESP	Bhp	Watts	ESP	Bhp	Watts	ESP	Bhp	Watts	ESP	Bhp	Watts
1500	0.88	0.67	750	1.20	0.71	791	1.19	0.70	782	1.36	0.76	845	1.38	0.79	875	1.44	0.85	949
1600	0.68	0.70	780	1.04	0.74	824	1.04	0.74	821	1.22	0.79	883	1.25	0.82	913	1.33	0.89	988
1700	0.51	0.73	810	0.89	0.77	857	0.89	0.77	861	1.09	0.83	921	1.13	0.85	950	1.22	0.92	1027
1800	0.35	0.75	839	0.73	0.80	891	0.74	0.81	900	0.96	0.86	959	1.00	0.89	988	1.11	0.96	1066
1900	0.26	0.78	873	0.58	0.83	924	0.59	0.84	940	0.86	0.90	997	0.88	0.92	1025	1.00	0.99	1105
2000	0.18	0.81	905	0.42	0.86	957	0.44	0.88	979	0.73	0.93	1035	0.78	0.95	1063	0.92	1.03	1144
2100	0.08	0.84	940	0.27	0.89	990	0.29	0.91	1018	0.59	0.96	1073	0.63	0.99	1101	0.81	1.06	1183
2200	—	—	—	0.19	0.92	1023	0.19	0.93	1035	0.46	1.00	1111	0.49	1.02	1138	0.69	1.10	1222
2300	—	—	—	0.11	0.95	1056	0.11	0.97	1076	0.34	1.03	1149	0.41	1.06	1176	0.59	1.13	1261
2400	—	—	—	0.03	0.98	1096	0.04	1.00	1113	0.19	1.07	1187	0.22	1.09	1213	0.43	1.17	1300
2500	—	—	—	—	—	—	—	—	—	0.09	1.10	1225	0.12	1.12	1251	0.34	1.20	1340

<b>PHS060 (5 TONS) — HIGH-STATIC MOTOR AND DRIVE* (Belt Drive)</b>																	
Airflow (Cfm)	External Static Pressure (in. wg)																
	0.2			0.4			0.6			0.8			1.0				
	Rpm	Bhp	Watts	Rpm	Bhp	Watts	Rpm	Bhp	Watts	Rpm	Bhp	Watts	Rpm	Bhp	Watts		
1500	807	0.42	369	913	0.56	489	1011	0.71	621	1103	0.87	766	1188	1.05	923		
1600	847	0.49	432	948	0.63	557	1042	0.79	694	1130	0.96	843	1213	1.14	1003		
1700	887	0.57	501	983	0.72	632	1073	0.88	774	1158	1.06	928	1239	1.24	1092		
1800	928	0.66	579	1020	0.82	715	1106	0.98	863	1188	1.16	1021	1266	1.35	1189		
1900	969	0.76	666	1057	0.92	808	1140	1.09	960	1219	1.28	1123	1295	1.48	1296		
2000	1010	0.87	761	1095	1.04	909	1175	1.21	1066	1251	1.41	1234	1325	1.61	1411		
2100	1052	0.99	866	1133	1.16	1019	1211	1.35	1182	1285	1.54	1355	1355	1.75	1537		
2200	1095	1.12	981	1173	1.30	1140	1247	1.49	1308	1319	1.69	1486	1387	1.91	1673		
2300	1137	1.26	1105	1212	1.45	1271	1284	1.65	1445	1353	1.85	1628	1420	2.07	1820		
2400	1180	1.41	1241	1252	1.61	1412	1322	1.81	1592	1389	2.03	1781	1454	2.25	1977		
2500	1223	1.58	1388	1293	1.78	1565	1360	1.99	1751	1425	2.22	1945	1488	2.45	2147		

<b>PHS060 (5 TONS) — HIGH-STATIC MOTOR AND DRIVE* (Belt Drive) (cont)</b>																	
Airflow (Cfm)	External Static Pressure (in. wg)																
	1.2			1.4			1.6			1.8			2.0				
	Rpm	Bhp	Watts	Rpm	Bhp	Watts	Rpm	Bhp	Watts	Rpm	Bhp	Watts	Rpm	Bhp	Watts		
1500	1270	1.24	1091	1347	1.45	1269	1421	1.66	1458	1492	1.89	1657	1561	2.13	1865		
1600	1292	1.34	1174	1367	1.54	1356	1440	1.76	1547	1509	1.99	1748	1576	2.23	1959		
1700	1315	1.44	1267	1389	1.65	1451	1459	1.88	1646	1527	2.11	1849	1593	2.35	2062		
1800	1341	1.56	1368	1412	1.77	1556	1481	2.00	1753	1547	2.23	1960	1612	2.48	2175		
1900	1367	1.68	1478	1437	1.90	1670	1504	2.13	1871	1569	2.37	2080	1632	2.62	2299		
2000	1395	1.82	1598	1463	2.04	1794	1528	2.28	1998	1591	2.52	2212	1653	2.77	2433		
2100	1424	1.97	1728	1490	2.20	1928	1554	2.43	2136	1615	2.68	2353	—	—	—		
2200	1454	2.13	1869	1518	2.36	2073	1580	2.60	2285	1641	2.85	2505	—	—	—		
2300	1485	2.30	2020	1547	2.54	2228	1608	2.79	2445	—	—	—	—	—	—		
2400	1516	2.49	2182	1577	2.73	2395	—	—	—	—	—	—	—	—	—		
2500	1549	2.69	2357	—	—	—	—	—	—	—	—	—	—	—	—		

**LEGEND**

**Bhp** — Brake Horsepower Input to Fan

**Watts** — Input Watts to Motor

\*Motor drive range: 1300 to 1685 rpm. All other rpms require a field-supplied drive.

**NOTES**

1. Bold data indicates field-supplied drive is required.

2. Maximum continuous Bhp is 2.90.

3. See GENERAL FAN PERFORMANCE NOTES following this section.

**GENERAL NOTES FOR FAN PERFORMANCE TABLES:**

1. Extensive motor and electrical testing on these units ensures that the full range of the motor can be utilized with confidence. Using your fan motors up to the wattage ratings shown will not result in nuisance tripping or premature motor failure. Unit warranty will not be affected. For additional information on motor performance, refer to Indoor Fan Motor Performance table.
2. Values include losses for filters, unit casing, and wet coils. Refer to Accessory/FIOP Static Pressure tables for accessory static pressure information.
3. Use of a field-supplied motor may affect wire sizing. Contact your dealer or representative for details.
4. Interpolation is permissible. Do not extrapolate.



**PERFORMANCE DATA - PHS036-060 (cont.)**

**FAN PERFORMANCE HORIZONTAL DISCHARGE UNITS**

PHS036 (3 TONS) — STANDARD MOTOR (DIRECT DRIVE)												
Airflow (Cfm)	Low Speed						High Speed					
	208 v			230, 460 v			208 v			230, 460 v		
	ESP	Bhp	Watts	ESP	Bhp	Watts	ESP	Bhp	Watts	ESP	Bhp	Watts
900	0.72	0.21	253	0.75	0.23	277	0.73	0.26	307	0.76	0.31	363
1000	0.67	0.23	270	0.69	0.25	292	0.70	0.27	321	0.71	0.32	374
1100	0.61	0.24	287	0.63	0.26	307	0.64	0.28	335	0.65	0.33	385
1200	0.57	0.26	304	0.58	0.27	323	0.56	0.29	349	0.59	0.34	397
1300	0.51	0.27	321	0.53	0.29	338	0.53	0.31	364	0.54	0.34	408
1400	0.44	0.29	338	0.46	0.30	354	0.47	0.32	378	—	—	—
1500	0.39	0.30	355	0.41	0.31	369	0.43	0.33	392	—	—	—

**LEGEND**

**Bhp** — Brake Horsepower Input to Fan

**ESP** — External Static Pressure (in. wg)

**Watts** — Input Watts to Motor

See GENERAL FAN PERFORMANCE NOTES following this section.

PHS036 (3 TONS) — HIGH-STATIC MOTOR (BELT DRIVE)*															
Airflow (Cfm)	External Static Pressure (in. wg)														
	0.2			0.4			0.6			0.8			1.0		
	Rpm	Bhp	Watts	Rpm	Bhp	Watts	Rpm	Bhp	Watts	Rpm	Bhp	Watts	Rpm	Bhp	Watts
900	607	0.14	142	745	0.22	221	856	0.31	304	952	0.39	393	1037	0.49	485
1000	640	0.18	174	775	0.26	261	884	0.35	351	978	0.45	446	1062	0.55	545
1100	674	0.21	212	805	0.31	307	912	0.41	404	1005	0.51	506	1089	0.61	611
1200	708	0.26	256	836	0.36	359	941	0.47	464	1033	0.57	572	1116	0.69	683
1300	743	0.31	307	868	0.42	417	971	0.53	530	1062	0.65	645	1143	0.77	764
1400	780	0.37	364	900	0.49	483	1002	0.61	603	1091	0.73	726	1172	0.86	851
1500	816	0.43	428	934	0.56	556	1033	0.69	685	1121	0.82	815	1201	0.95	947

PHS036 (3 TONS) — HIGH-STATIC MOTOR * (BELT DRIVE) (cont)															
Airflow (Cfm)	External Static Pressure (in. wg)														
	1.2			1.4			1.6			1.8			2.0		
	Rpm	Bhp	Watts	Rpm	Bhp	Watts	Rpm	Bhp	Watts	Rpm	Bhp	Watts	Rpm	Bhp	Watts
900	1114	0.59	582	1186	0.69	684	1253	0.79	789	1316	0.90	898	1375	1.02	1010
1000	1139	0.65	648	1210	0.76	754	1277	0.87	865	1340	0.98	979	1399	1.10	1097
1100	1165	0.72	720	1236	0.84	832	1302	0.95	948	1364	1.07	1068	1423	1.20	1191
1200	1191	0.80	799	1261	0.92	917	1327	1.04	1039	1389	1.17	1165	1448	1.30	1293
1300	1218	0.89	885	1288	1.02	1010	1353	1.14	1138	1414	1.28	1270	1473	1.41	1404
1400	1246	0.99	980	1315	1.12	1111	1379	1.25	1246	1440	1.39	1383	1499	1.53	1523
1500	1274	1.09	1083	1342	1.23	1221	1406	1.37	1362	1467	1.51	1505	1525	1.66	1652

**LEGEND**

**Bhp** — Brake Horsepower Input to Fan

**Watts** — Input Watts to Motor

\*Motor drive range: 1075 to 1455 rpm. All other rpms require a field-supplied drive.

**NOTES**

1. Bold data indicates field-supplied drive is required.

2. Maximum continuous Bhp is 2.40.

3. See GENERAL FAN PERFORMANCE NOTES following this section.

**PERFORMANCE DATA - PHS036-060 (cont.)**

**FAN PERFORMANCE HORIZONTAL DISCHARGE UNITS**

PHS048 (4 TONS) — STANDARD MOTOR (DIRECT DRIVE)												
Airflow (Cfm)	Low Speed						High Speed					
	208 v			230, 460 v			208 v			230, 460 v		
	ESP	Bhp	Watts	ESP	Bhp	Watts	ESP	Bhp	Watts	ESP	Bhp	Watts
1200	0.93	0.41	458	0.94	0.45	506	0.94	0.51	572	0.99	0.56	632
1300	0.86	0.42	471	0.87	0.46	521	0.87	0.52	589	0.92	0.58	651
1400	0.78	0.45	503	0.79	0.49	556	0.79	0.54	616	0.87	0.60	681
1500	0.70	0.47	536	0.73	0.52	593	0.73	0.56	631	0.80	0.62	698
1600	0.61	0.49	557	0.64	0.54	616	0.66	0.58	654	0.76	0.64	723
1700	0.51	0.52	584	0.54	0.57	646	0.58	0.60	678	0.68	0.66	750
1800	0.40	0.54	610	0.44	0.60	674	0.51	0.62	698	0.63	0.68	772
1900	0.29	0.56	629	0.37	0.62	696	0.46	0.64	720	0.56	0.70	796
2000	0.25	0.58	651	0.30	0.64	720	0.39	0.66	744	0.50	0.73	823

**LEGEND**

**Bhp** — Brake Horsepower Input to Fan

**ESP** — External Static Pressure (in. wg)

**Watts** — Input Watts to Motor

See GENERAL FAN PERFORMANCE NOTES following this section.

PHS048 (4 TONS) — HIGH-STATIC MOTOR (BELT DRIVE)*															
Airflow (Cfm)	External Static Pressure (in. wg)														
	0.2			0.4			0.6			0.8			1.0		
	Rpm	Bhp	Watts	Rpm	Bhp	Watts	Rpm	Bhp	Watts	Rpm	Bhp	Watts	Rpm	Bhp	Watts
1200	708	0.26	256	836	0.36	359	941	0.47	464	1033	0.57	572	1116	0.69	683
1300	743	0.31	307	868	0.42	417	971	0.53	530	1062	0.65	645	1143	0.77	764
1400	780	0.37	364	900	0.49	483	1002	0.61	603	1091	0.73	726	1172	0.86	851
1500	816	0.43	428	934	0.56	556	1033	0.69	685	1121	0.82	815	1201	0.95	947
1600	854	0.50	501	968	0.64	638	1065	0.78	774	1152	0.92	912	1230	1.06	1052
1700	892	0.59	582	1002	0.73	728	1098	0.88	872	1183	1.02	1018	1260	1.17	1166
1800	930	0.68	672	1038	0.83	826	1131	0.99	980	1215	1.14	1134	1291	1.30	1289
1900	969	0.78	772	1073	0.94	935	1165	1.10	1097	1247	1.27	1259	1322	1.43	1422
2000	1008	0.89	881	1110	1.06	1054	1199	1.23	1224	1280	1.40	1395	1354	1.57	1566

PHS048 (4 TONS) — HIGH-STATIC MOTOR (BELT DRIVE)* (cont)															
Air-flow (Cfm)	External Static Pressure (in. wg)														
	1.2			1.4			1.6			1.8			2.0		
	Rpm	Bhp	Watts	Rpm	Bhp	Watts	Rpm	Bhp	Watts	Rpm	Bhp	Watts	Rpm	Bhp	Watts
1200	1191	0.80	799	1261	0.92	917	1327	1.04	1039	1389	1.17	1165	1448	1.30	1293
1300	1218	0.89	885	1288	1.02	1010	1353	1.14	1138	1414	1.28	1270	1473	1.41	1404
1400	1246	0.99	980	1315	1.12	1111	1379	1.25	1246	1440	1.39	1383	1499	1.53	1523
1500	1274	1.09	1083	1342	1.23	1221	1406	1.37	1362	1467	1.51	1505	1525	1.66	1652
1600	1303	1.20	1194	1370	1.35	1339	1434	1.49	1487	1494	1.65	1637	1551	1.80	1790
1700	1332	1.32	1315	1399	1.48	1467	1462	1.63	1622	1522	1.79	1778	1579	1.95	1938
1800	1362	1.45	1446	1428	1.61	1605	1490	1.78	1767	1550	1.94	1930	1606	2.11	2096
1900	1392	1.60	1587	1458	1.76	1753	1519	1.93	1922	1578	2.10	2092	1634	2.28	2265
2000	1423	1.75	1738	1488	1.92	1912	1549	2.10	2088	1607	2.28	2266	—	—	—

**LEGEND**

**Bhp** — Brake Horsepower Input to Fan

**Watts** — Input Watts to Motor

\*Motor drive range: 1075 to 1455 rpm. All other rpms require a field-supplied drive.

**NOTES**

1. Bold data indicates field-supplied drive is required.

2. Maximum continuous Bhp is 2.40.

3. See GENERAL FAN PERFORMANCE NOTES following this section.

**PERFORMANCE DATA - PHS036-060 (cont.)**

**FAN PERFORMANCE HORIZONTAL DISCHARGE UNITS**

PHS060 (5 TONS) — STANDARD MOTOR (DIRECT DRIVE)*																		
Air-flow (Cfm)	Low Speed						Medium Speed						High Speed					
	208 v			230, 460, 575 v			208 v			230, 460, 575 v			208 v			230, 460, 575 v		
	ESP	Bhp	Watts	ESP	Bhp	Watts	ESP	Bhp	Watts	ESP	Bhp	Watts	ESP	Bhp	Watts	ESP	Bhp	Watts
1500	1.01	0.67	750	1.25	0.71	791	1.26	0.70	782	1.46	0.76	845	1.46	0.79	875	1.52	0.85	949
1600	0.82	0.70	780	1.09	0.74	824	1.11	0.74	821	1.32	0.79	883	1.33	0.82	913	1.41	0.89	988
1700	0.64	0.73	810	0.97	0.77	857	0.99	0.77	861	1.22	0.83	921	1.24	0.85	950	1.33	0.92	1027
1800	0.44	0.75	839	0.81	0.80	891	0.84	0.80	900	1.09	0.86	959	1.11	0.89	988	1.22	0.96	1066
1900	0.32	0.78	869	0.66	0.83	924	0.69	0.83	940	0.96	0.90	997	0.99	0.92	1025	1.11	0.99	1105
2000	0.21	0.81	899	0.47	0.86	957	0.51	0.86	979	0.80	0.93	1035	0.83	0.95	1063	0.97	1.03	1144
2100	0.13	0.83	929	0.32	0.89	990	0.36	0.89	1018	0.64	0.96	1073	0.71	0.99	1101	0.86	1.06	1183
2200	0.05	0.86	959	0.19	0.92	1023	0.21	0.92	1058	0.50	1.00	1111	0.58	1.02	1138	0.75	1.10	1222
2300	—	—	—	0.08	0.95	1057	0.08	0.95	1097	0.34	1.03	1149	0.39	1.06	1176	0.57	1.13	1261
2400	—	—	—	—	—	—	—	—	—	0.24	1.07	1187	0.29	1.09	1213	0.49	1.17	1300
2500	—	—	—	—	—	—	—	—	—	0.15	1.10	1225	0.15	1.12	1251	0.34	1.20	1340

**LEGEND**

**Bhp** — Brake Horsepower Input to Fan

**ESP** — External Static Pressure (in. wg)

**Watts** — Input Watts to Motor

See GENERAL FAN PERFORMANCE NOTES following this section.

PHS060 (5 TONS) — HIGH-STATIC MOTOR (BELT DRIVE)*																
Airflow	External Static Pressure (in. wg)															
	0.2			0.4			0.6			0.8			1.0			
	Rpm	Bhp	Watts	Rpm	Bhp	Watts	Rpm	Bhp	Watts	Rpm	Bhp	Watts	Rpm	Bhp	Watts	
1500	776	0.38	340	883	0.51	454	977	0.65	579	1061	0.80	715	1138	0.97	860	
1600	813	0.45	397	916	0.58	517	1007	0.73	646	1089	0.89	786	1165	1.05	935	
1700	851	0.52	461	949	0.66	586	1038	0.81	721	1118	0.97	865	1192	1.15	1018	
1800	888	0.60	532	984	0.75	662	1069	0.90	802	1148	1.07	951	1221	1.25	1109	
1900	927	0.69	610	1019	0.84	747	1102	1.00	892	1179	1.18	1046	1250	1.36	1208	
2000	965	0.78	697	1054	0.94	839	1135	1.11	990	1210	1.29	1149	1280	1.48	1316	
2100	1004	0.89	792	1090	1.06	940	1169	1.23	1096	1242	1.42	1260	1310	1.61	1432	
2200	1044	1.01	896	1127	1.18	1050	1203	1.36	1211	1274	1.55	1381	1341	1.75	1557	
2300	1084	1.14	1009	1164	1.32	1169	1238	1.50	1336	1308	1.70	1511	1373	1.91	1693	
2400	1123	1.27	1132	1201	1.46	1298	1273	1.66	1471	1341	1.86	1651	1405	2.07	1838	
2500	1164	1.42	1265	1239	1.62	1437	1309	1.82	1616	1375	2.03	1801	1438	2.24	1994	

PHS060 (5 TONS) — HIGH-STATIC MOTOR (BELT DRIVE)* (cont)																
Airflow (Cfm)	External Static Pressure (in. wg)															
	1.2			1.4			1.6			1.8			2.0			
	Rpm	Bhp	Watts	Rpm	Bhp	Watts	Rpm	Bhp	Watts	Rpm	Bhp	Watts	Rpm	Bhp	Watts	
1500	1210	1.14	1014	1278	1.33	1178	1342	1.52	1350	1403	1.72	1530	1461	1.93	1717	
1600	1236	1.23	1094	1302	1.42	1261	1365	1.62	1436	1425	1.82	1618	1483	2.04	1809	
1700	1262	1.33	1181	1328	1.52	1351	1390	1.72	1530	1449	1.93	1716	1505	2.15	1910	
1800	1289	1.44	1276	1354	1.63	1450	1415	1.84	1632	1473	2.05	1822	1529	2.27	2019	
1900	1317	1.55	1379	1380	1.75	1557	1441	1.96	1743	1498	2.18	1937	1553	2.41	2137	
2000	1345	1.68	1491	1408	1.88	1673	1467	2.10	1863	1524	2.32	2060	1579	2.55	2264	
2100	1375	1.81	1611	1436	2.03	1798	1494	2.24	1993	1550	2.47	2194	1604	2.70	2401	
2200	1405	1.96	1742	1465	2.18	1933	1522	2.40	2132	1578	2.63	2337	1631	2.87	2548	
2300	1435	2.12	1882	1494	2.34	2078	1551	2.57	2280	1605	2.80	2490	—	—	—	
2400	1466	2.29	2032	1524	2.51	2232	1580	2.75	2440	—	—	—	—	—	—	
2500	1498	2.47	2193	1555	2.70	2398	—	—	—	—	—	—	—	—	—	

**LEGEND**

**Bhp** — Brake Horsepower Input to Fan

**Watts** — Input Watts to Motor

\*Motor drive range: 1300 to 1685 rpm. All other rpms require a field-supplied drive.

**NOTES**

1. Bold data indicates field-supplied drive is required.

2. Maximum continuous Bhp is 2.90.

3. See GENERAL FAN PERFORMANCE NOTES following this section.

**GENERAL NOTES FOR FAN PERFORMANCE TABLES:**

1. Extensive motor and electrical testing on these units ensures that the full range of the motor can be utilized with confidence. Using your fan motors up to the wattage ratings shown will not result in nuisance tripping or premature motor failure. Unit warranty will not be affected. For additional information on motor performance, refer to Indoor Fan Motor Performance table.
2. Values include losses for filters, unit casing, and wet coils. Refer to Accessory/FIOP Static Pressure tables for accessory static pressure information.
3. Use of a field-supplied motor may affect wire sizing. Contact your dealer or representative for details.
4. Interpolation is permissible. Do not extrapolate.

**PERFORMANCE DATA - PHS036-060 (cont.)**

**FAN RPM AT MOTOR PULLEY SETTINGS\***

UNIT	MOTOR PULLEY TURNS OPEN												
	0	1/2	1	1 1/2	2	2 1/2	3	3 1/2	4	4 1/2	5	5 1/2	6
<b>036**</b>	1455	1423	1392	1360	1328	1297	1265	1233	1202	1170	1138	1107	1075
<b>048**</b>	1455	1423	1392	1360	1328	1297	1265	1233	1202	1170	1138	1107	1075
<b>060**</b>	1685	1647	1608	1570	1531	1493	1454	1416	1377	1339	1300	—	—

\*Approximate fan rpm shown

\*\*Indicates high-static motor and drive packaged drive package

**ACCESSORY/HEATER STATIC PRESSURE\* (in. wg)**

COMPONENT	CFM										
	900	1200	1400	1600	1800	2000	2200	2400	2600	3000	
<b>1 Heater Module</b>	0.05	0.07	0.09	0.09	0.10	0.11	0.11	0.12	0.13	0.15	
<b>2 Heater Modules</b>	0.15	0.16	0.16	0.16	0.17	0.17	0.17	0.18	0.18	0.19	

\*The static pressure must be added to external static pressure. The sum and the evaporator entering-air cfm should then be used in conjunction with the Fan Performance tables to determine blower rpm and watts.

**ACCESSORY/FIOP STATIC PRESSURE\* (in. wg)**

COMPONENT	CFM							
	1250	1500	1750	2000	2250	2500	2750	3000
<b>Vertical Economizer</b>	0.045	0.065	0.08	0.12	0.145	0.175	0.22	0.255
<b>Horizontal Economizer</b>	—	—	0.1	0.125	0.15	0.18	0.225	0.275

FIOP - Factory Installed Option

\*The static pressure must be added to external static pressure. The sum and the evaporator entering-air cfm should then be used in conjunction with the Fan Performance tables to determine blower rpm and watts.

**INDOOR FAN MOTOR PERFORMANCE**

PHS 036-060	INDOOR-FAN MOTOR	UNIT VOLTAGE	MAXIMUM ACCEPTABLE CONTINUOUS BHP*	MAXIMUM ACCEPTABLE OPERATING WATTS	MAXIMUM AMP DRAW	MOTOR EFFICIENCY (%)
<b>036</b>	Standard	208/230	0.34	440	2.8	75
		460			1.3	
		575			1.3	
	High Static	208/230	2.40	2120	6.0	
		460			3.0	
		575			3.0	
<b>048</b>	Standard	208/230	0.75	850	3.5	75
		460			1.8	
		575			1.8	
	High Static	208/230	2.40	2120	6.0	
		460			3.0	
		575			3.0	
<b>060</b>	Standard	208/230	1.20	1340	5.9	74
		460			3.2	
		575			3.2	
	High Static	208/230	2.90	2562	8.6	
		460			3.9	
		575			3.9	

**NOTES:**

**BHP** — Brake Horsepower

\*Extensive motor and electrical testing on these units ensures that the full horsepower range of the motors can be utilized with confidence. Using your fan motors up to the horsepower ratings shown in this table will not result in nuisance tripping or premature motor failure. Unit warranty will not be affected.

1. All indoor-fan motors 5 hp and larger meet the minimum efficiency requirements as established by the Energy Policy Act of 1992 (EPACT) effective - October 24, 1997.

**ELECTRICAL DATA - PHS036-060**

**UNITS WITHOUT ELECTRICAL CONVENIENCE OUTLET**

UNIT PHS	NOMINAL V-PH-Hz	IFM TYPE	VOLTAGE RANGE		COMPRESSOR (each)		OFM FLA	IFM FLA	ELECTRIC HEAT*		POWER SUPPLY		DISCONNECT SIZE†		
			Min	Max	RLA	LRA			Nominal kW**	FLA	MCA	MOCP	FLA	LRA	
036 (3 Tons)	208/230-3-60	STD	187	254	10.2	75.0	1.5	3.1	—	—	17.8/ 17.8	20/ 20††	17/ 17	86/ 86	
									3.3/ 4.4	9.2/10.6	29.3/ 31.0	30/ 35††	28/ 30	95/ 97	
									4.9/ 6.5	13.6/15.6	34.8/ 37.3	35/ 40††	33/ 35	100/102	
									6.5/ 8.7	18.0/20.9	40.3/ 43.9	45/ 45††	38/ 42	104/107	
									7.9/10.5	21.9/25.3	45.1/ 49.4	50/ 50††	43/ 47	108/111	
									12.0/16.0	33.3/38.5	59.4/ 65.9	60/ 70	56/ 62	119/124	
		HIGH-STATIC	187	254	10.2	75.0	1.5	5.8	—	—	20.1/ 20.1	25/ 25††	20/ 20	120/120	
									3.3/ 4.4	9.2/10.6	31.6/ 33.3	35/ 35††	31/ 32	129/130	
	460-3-60	STD	414	508	4.8	40.0	0.8	1.7	—	—	8.1	15††	8	45	
									6.0	7.2	17.1	20††	16	52	
									8.8	10.6	21.4	25††	20	55	
									11.5	13.8	25.4	30††	24	59	
		HIGH-STATIC	414	508	4.8	40.0	0.8	2.6	—	—	9.4	15††	9	62	
									6.0	7.2	18.4	20††	18	70	
									8.8	10.6	22.7	25††	22	73	
									11.5	13.8	26.7	30††	25	76	
048 (4 Tons)	208/230-3-60	STD	187	254	16.8	91.0	1.5	3.5	—	—	26.0/ 26.0	30/ 30††	25/ 25	102/102	
									4.9/ 6.5	13.6/15.6	43.0/ 45.5	45/ 50††	41/ 43	115/117	
									6.5/ 8.7	18.0/20.9	48.5/ 52.1	50/ 60††	46/ 49	120/123	
									12.0/16.0	33.3/38.5	67.6/ 74.1	70/ 80	63/ 69	135/140	
									15.8/21.0	43.9/50.5	80.9/ 89.1	90/ 90	76/ 83	146/152	
	460-3-60	HIGH-STATIC	187	254	16.8	91.0	1.5	5.8	—	—	28.3/ 28.3	30/ 30††	28/ 28	136/136	
									4.9/ 6.5	13.6/15.6	45.3/ 47.8	50/ 50††	43/ 46	149/151	
									6.5/ 8.7	18.0/20.9	50.8/ 54.4	60/ 60††	48/ 52	154/157	
									12.0/16.0	33.3/38.5	69.9/ 76.4	70/ 80	66/ 72	169/174	
									15.8/21.0	43.9/50.5	83.2/ 91.4	90/100	78/ 86	180/186***	
060 (5 Tons)	460-3-60	STD	414	508	8.4	50.0	0.8	1.8	—	—	13.1	15††	13	56	
									6.0	7.2	22.1	25††	21	63	
									11.5	13.8	30.4	35††	29	70	
									14.0	16.8	34.1	35††	32	73	
									23.0	27.7	47.7	50††	45	84	
		HIGH-STATIC	414	508	8.4	50.0	0.8	2.6	—	—	13.9	15††	14	72	
									6.0	7.2	22.9	25††	22	80	
									11.5	13.8	31.2	35††	29	86	
									14.0	16.8	34.9	35††	33	89	
									23.0	27.7	48.5	50††	45	100	
	208/230-3-60	STD	187	254	15.4	124.0	1.5	5.9	—	—	26.7/ 26.7	30/ 30††	26/ 26	138/138	
									4.9/ 6.5	13.6/15.6	43.7/ 46.2	45/ 50††	42/ 44	152/154	
									7.9/10.5	21.9/25.3	54.0/ 58.3	60/ 60††	51/ 55	160/163	
									12.0/16.0	33.3/38.5	68.3/ 74.8	70/ 80	65/ 70	171/177	
									15.8/21.0	43.9/50.5	81.5/ 89.8	90/ 90	77/ 84	182/189***	
									19.9/26.5	55.2/63.8	95.7/106.4	100/110	90/100	193/202***	
									HIGH-STATIC	187	254	15.4	124.0	1.5	7.5
		4.9/ 6.5	13.6/15.6	45.3/ 47.8	50/ 50††	44/ 46	201/203								
		7.9/10.5	21.9/25.3	55.6/ 59.9	60/ 60††	53/ 57	210/213								
		12.0/16.0	33.3/38.5	69.9/ 76.4	70/ 80	66/ 72	221/226								
		15.8/21.0	43.9/50.5	83.1/ 91.4	90/100	79/ 86	232/238***								
		19.9/26.5	55.2/63.8	97.3/108.0	100/110	92/101	243/252***								
		460-3-60	STD	414	508	7.7	59.6	0.8							
									6.0	7.2	22.6	25††	22	75	
11.5	13.8								30.9	35††	29	81			
14.0	16.8								34.6	35††	33	84			
HIGH-STATIC	414		508	7.7	59.6	0.8	3.4	—	—	13.8	15††	14	92		
								6.0	7.2	22.8	25††	22	99		
								11.5	13.8	31.1	35††	30	105		
								14.0	16.8	34.8	35††	33	108		

NOTE: See Legend and Notes for Electrical Data following this section.

## ELECTRICAL DATA - PHS036-060 (cont.)

### LEGEND

**FLA** — Full Load Amps  
**HACR** — Heating, Air Conditioning and Refrigeration  
**IFM** — Indoor Fan Motor  
**LRA** — Locked Rotor Amps  
**MCA** — Minimum Circuit Amps  
**MOCP** — Maximum Overcurrent Protection  
**NEC** — National Electrical Code  
**OFM** — Outdoor Fan Motor  
**RLA** — Rated Load Amps



\*Heaters are field installed only.

†Used to determine minimum disconnect size per NEC.

\*\*Heater capacity (kW) is based on heater voltage of 208 v, 240 v and 480 v. If power distribution voltage to unit varies from rated heater voltage, heater kW will vary accordingly.

††Fuse or HACR circuit breaker.

\*\*\*Optional disconnect switch is unavailable.

### NOTES:

1. In compliance with NEC requirements for multimotor and combination load equipment (refer to NEC Articles 430 and 440), the overcurrent protective device for the unit shall be fuse or HACR breaker.

2. **Unbalanced 3-Phase Supply Voltage** *Never operate a motor where a phase imbalance in supply voltage is greater than 2%.* Use the following formula to determine the percent of voltage imbalance.

% Voltage Imbalance

$$= 100 \times \frac{\text{max voltage deviation from average voltage}}{\text{average voltage}}$$

Example: Supply voltage is 460-3-60.

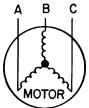

AB = 452 v  
 BC = 464 v  
 AC = 455 v

$$\text{Average Voltage} = \frac{452 + 464 + 455}{3}$$

$$= \frac{31371}{3}$$

$$= 457$$

Determine maximum deviation from average voltage.

$$\text{(AB)} \ 457 - 452 = 5 \text{ v}$$

$$\text{(BC)} \ 464 - 457 = 7 \text{ v}$$

$$\text{(AC)} \ 457 - 455 = 2 \text{ v}$$

Maximum deviation is 7 v.

Determine percent of voltage imbalance.

$$\begin{aligned} \% \text{ Voltage Imbalance} &= 100 \times \frac{7}{457} \\ &= 1.53\% \end{aligned}$$

This amount of phase imbalance is satisfactory as it is below the maximum allowable 2%.

**IMPORTANT:** If the supply voltage phase imbalance is more than 2%, contact your local electric utility company immediately.

### POWER EXHAUST ELECTRICAL DATA

POWER EXHAUST PART NO.	MCA (230 v)	MCA (460 v)	MCA (575 v)	MOCP (for separate power source)
DNPWREXH021A01	N/A	0.68	N/A	15
DNPWREXH022A01	3.4	N/A	1.32	15
DNPWREXH023A01	N/A	1.4	N/A	15
DNPWREXH028A01	1.7	N/A	0.68	15
DNPWREXH029A01	N/A	0.7	N/A	15
DNPWREXH030A01	1.6	N/A	0.64	15

N/A — Not available

NOTE: If a single power source is to be used, size wire to include power exhaust MCA and MOCP.

Check MCA and MOCP when power exhaust is powered through the unit. Determine the new MCA including the power exhaust using the following formula:

$$\text{MCA New} = \text{MCA unit only} + \text{MCA of Power Exhaust}$$

For example, using a PHS060 unit with MCA = 35.6 and

MOCP = 40, with DNPWREXH030A01 power exhaust.

$$\text{MCA New} = 35.6 \text{ amps} + 1.6 \text{ amps} = 37.2 \text{ amps}$$

If the new MCA does not exceed the published MOCP, then MOCP would not change. The MOCP in this example is 40 amps and the MCA New is below 40; therefore the MOCP is acceptable. If "MCA New" is larger than the published MOCP, raise the MOCP to the next larger size. In all cases, the MOCP for the power exhaust should be 15 amps per NEC.

**ELECTRICAL DATA - PHS036-060 (cont.)**

**UNITS WITH ELECTRICAL CONVENIENCE OUTLET**

UNIT PHS	NOMINAL V-PH-Hz	IFM TYPE	VOLTAGE RANGE		COMPRESSOR (each)		OFM FLA	IFM FLA	ELECTRIC HEAT*		POWER SUPPLY		DISCONNECT SIZE†		
			Min	Max	RLA	LRA			Nominal kW**	FLA	MCA	MOCP	FLA	LRA	
			(3 Tons) 036	208/230-3-60	STD	187			254	10.2	75.0	1.5	3.1	—	—
3.3/ 4.4	9.2/ 10.6	34.1/ 35.8					35/ 40††	34/ 35						100/ 101	
4.9/ 6.5	13.6/ 15.6	39.6/ 42.1					40/ 45††	39/ 41						104/ 106	
High-Static	187	254			10.2	75.0	1.5	5.8	—	—	24.9/ 24.9	25/ 25††	26/ 26	125/ 125	
									3.3/ 4.4	9.2/ 10.6	36.4/ 38.1	40/ 40††	36/ 38	134/ 135	
									4.9/ 6.5	13.6/ 15.6	41.9/ 44.4	45/ 45††	41/ 44	138/ 140	
460-3-60	STD	414		508	4.8	40.0	0.8	1.7	—	—	10.3	15††	10	47	
									6.0	7.2	19.3	20††	19	54	
									8.8	10.6	23.5	25††	23	58	
	High-Static	414		508	4.8	40.0	0.8	2.6	—	—	11.6	15††	12	65	
									6.0	7.2	20.6	25††	20	72	
									8.8	10.6	24.8	25††	24	75	
(048) 048	208/230-3-60	STD		187	254	16.8	91.0	1.5	3.5	—	—	30.8/ 30.8	35/ 35††	31/ 31	107/ 107
										4.9/ 6.5	13.6/ 15.6	47.8/ 50.3	50/ 60††	46/ 49	120/ 122
										6.5/ 8.7	18.0/ 20.9	53.3/ 56.9	60/ 60††	51/ 55	125/ 127
		High-Static		187	254	16.8	91.0	1.5	5.8	—	—	33.1/ 33.1	35/ 35††	33/ 33	141/ 141
			4.9/ 6.5							13.6/ 15.6	50.1/ 52.6	60/ 60††	49/ 51	154/ 156	
			6.5/ 8.7							18.0/ 20.9	55.6/ 59.2	60/ 60††	54/ 57	159/ 161	
	460-3-60	STD	414	508	8.4	50.0	0.8	1.8	—	—	15.3	20††	15	58	
									6.0	7.2	24.3	25††	23	66	
									11.5	13.8	32.5	35††	31	72	
		HIGH-STATIC	414	508	8.4	50.0	0.8	2.6	—	—	16.1	20††	16	75	
									6.0	7.2	25.1	30††	24	82	
									11.5	13.8	33.3	35††	32	88	
	(060) 060	208/230-3-60	STD	187	254	15.4	124.0	1.5	5.9	—	—	31.5/ 31.5	35/ 40††	32/ 32	143/ 143
										4.9/ 6.5	13.6/ 15.6	48.5/ 51.0	50/ 60††	47/ 50	157/ 159
										7.9/ 10.5	21.9/ 25.3	58.8/ 63.1	60/ 70	57/ 61	165/ 168
			HIGH-STATIC	187	254	15.4	124.0	1.5	7.5	—	—	33.1/ 33.1	35/ 35††	34/ 34	193/ 193
4.9/ 6.5										13.6/ 15.6	50.1/ 52.6	60/ 60††	49/ 52	206/ 208	
7.9/ 10.5										21.9/ 25.3	60.4/ 64.7	70/ 70	59/ 63	214/ 218	
460-3-60		STD	414	508	7.7	59.6	0.8	3.2	—	—	15.8	20††	16	70	
									6.0	7.2	24.8	25††	24	77	
									11.5	13.8	33.1	35††	32	83	
		HIGH-STATIC	414	508	7.7	59.6	0.8	3.4	—	—	16.0	20††	16	94	
									6.0	7.2	25.0	25††	24	101	
									11.5	13.8	33.3	35††	32	107	

NOTE: See Legend and Notes for Electrical Data following this section.

## ELECTRICAL DATA - PHS036-060 (cont.)

### LEGEND

**FLA** — Full Load Amps  
**HACR** — Heating, Air Conditioning and Refrigeration  
**IFM** — Indoor Fan Motor  
**LRA** — Locked Rotor Amps  
**MCA** — Minimum Circuit Amps  
**MOCP** — Maximum Overcurrent Protection  
**NEC** — National Electrical Code  
**OFM** — Outdoor Fan Motor  
**RLA** — Rated Load Amps



\*Heaters are field installed only.

†Used to determine minimum disconnect size per NEC.

\*\*Heater capacity (kW) is based on heater voltage of 208 v, 240 v and 480 v. If power distribution voltage to unit varies from rated heater voltage, heater kW will vary accordingly.

††Fuse or HACR circuit breaker.

\*\*\*Optional disconnect switch is unavailable.

### NOTES:

1. In compliance with NEC requirements for multimotor and combination load equipment (refer to NEC Articles 430 and 440), the overcurrent protective device for the unit shall be fuse or HACR breaker.

2. **Unbalanced 3-Phase Supply Voltage** *Never operate a motor where a phase imbalance in supply voltage is greater than 2%.* Use the following formula to determine the percent of voltage imbalance.

% Voltage Imbalance

$$= 100 \times \frac{\text{max voltage deviation from average voltage}}{\text{average voltage}}$$

Example: Supply voltage is 460-3-60.

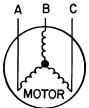

AB = 452 v  
 BC = 464 v  
 AC = 455 v

$$\text{Average Voltage} = \frac{452 + 464 + 455}{3}$$

$$= \frac{31371}{3}$$

$$= 457$$

Determine maximum deviation from average voltage.

$$\text{(AB)} \quad 457 - 452 = 5 \text{ v}$$

$$\text{(BC)} \quad 464 - 457 = 7 \text{ v}$$

$$\text{(AC)} \quad 457 - 455 = 2 \text{ v}$$

Maximum deviation is 7 v.

Determine percent of voltage imbalance.

$$\begin{aligned} \% \text{ Voltage Imbalance} &= 100 \times \frac{7}{457} \\ &= 1.53\% \end{aligned}$$

This amount of phase imbalance is satisfactory as it is below the maximum allowable 2%.

**IMPORTANT:** If the supply voltage phase imbalance is more than 2%, contact your local electric utility company immediately.

### POWER EXHAUST ELECTRICAL DATA

POWER EXHAUST PART NO.	MCA (230 v)	MCA (460 v)	MCA (575 v)	MOCP (for separate power source)
DNPWREXH021A01	N/A	0.68	N/A	15
DNPWREXH022A01	3.4	N/A	1.32	15
DNPWREXH023A01	N/A	1.4	N/A	15
DNPWREXH028A01	1.7	N/A	0.68	15
DNPWREXH029A01	N/A	0.7	N/A	15
DNPWREXH030A01	1.6	N/A	0.64	15

N/A — Not available

NOTE: If a single power source is to be used, size wire to include power exhaust MCA and MOCP.

Check MCA and MOCP when power exhaust is powered through the unit. Determine the new MCA including the power exhaust using the following formula:

$$\text{MCA New} = \text{MCA unit only} + \text{MCA of Power Exhaust}$$

For example, using a PHS060 unit with MCA = 35.6 and

MOCP = 40, with DNPWREXH030A01 power exhaust.

$$\text{MCA New} = 35.6 \text{ amps} + 1.6 \text{ amps} = 37.2 \text{ amps}$$

If the new MCA does not exceed the published MOCP, then MOCP would not change. The MOCP in this example is 40 amps and the MCA New is below 40; therefore the MOCP is acceptable. If "MCA New" is larger than the published MOCP, raise the MOCP to the next larger size. In all cases, the MOCP for the power exhaust should be 15 amps per NEC.



# Typical Schematic and Component Arrangement (208/230-3-60 Shown)

## SCHEMATIC

208/230-3-60

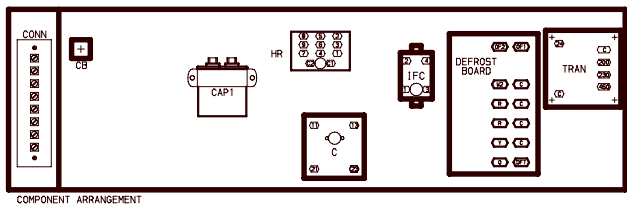
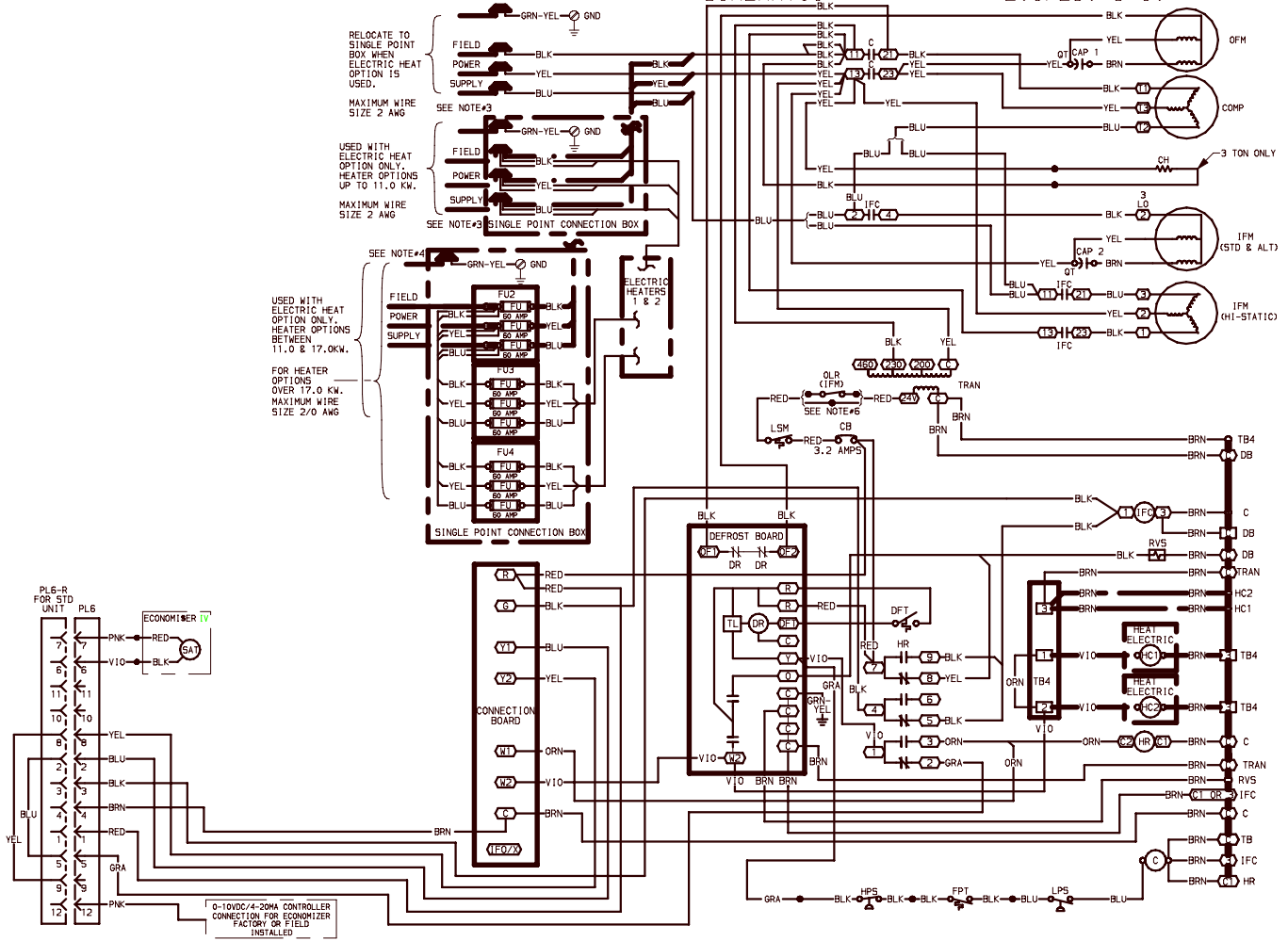

## LEGEND

- |  |  |
|--|--|
| <b>C</b> — Contactor, Compressor             | <b>TB</b> — Terminal Block                                 |
| <b>CAP</b> — Capacitor                       | <b>TRAN</b> — Transformer                                  |
| <b>CB</b> — Circuit Breaker                  | Field Splice   |
| <b>CH</b> — Crankcase Heater                 | Marked Wire  |
| <b>COMP</b> — Compressor Motor               | Terminal (Marked)  |
| <b>DB</b> — Defrost Board                    | Terminal (Unmarked)  |
| <b>DFT</b> — Defrost Thermostat              | Terminal Block   |
| <b>EQUIP</b> — Equipment                     | Splice   |
| <b>FPT</b> — Freeze-Up Protection Thermostat | Splice (Marked)  |
| <b>FU</b> — Fuse                             | Factory Wiring   |
| <b>GND</b> — Ground                          | Field Control Wiring                                       |
| <b>HC</b> — Heater Contactor                 | Field Power Wiring   |
| <b>HPS</b> — High-Pressure Switch            | Accessory or Optional Wiring                               |
| <b>HR</b> — Heat Relay                       | To indicate common potential only, not to represent wiring |
| <b>IFC</b> — Indoor Fan Contactor            |  |
| <b>IFM</b> — Indoor-Fan Motor                |  |
| <b>LPS</b> — Low-Pressure Switch             |  |
| <b>LSM</b> — Limit Switch (Motor)            |  |
| <b>OFM</b> — Outdoor-Fan Motor               |  |
| <b>OLR</b> — Overload Relay                  |  |
| <b>P</b> — Plug                              |  |
| <b>PL</b> — Plug Assembly                    |  |
| <b>QT</b> — Quadruple Terminal               |  |
| <b>RVS</b> — Reversing Valve Solenoid        |  |
| <b>SAT</b> — Supply Air Thermostat           |  |

## NOTES:

- If any of the original wire furnished must be replaced, it must be replaced with type 90 C wire or its equivalent.
- Three phase motors are protected under primary single phasing conditions.
- Use copper conductors only.
- Use copper, copper-clad aluminum or aluminum conductors.
- | Voltage Rating |                    | Must Trip Amps |
|----------------|--------------------|----------------|
| 24V            | POTTER & BRUMFIELD | 3.2            |
|                | W2BX-1024-3.2      |                |
- Unit will have either OLR or LSM, but not both.

# ECONOMIZER WIRING - PHS

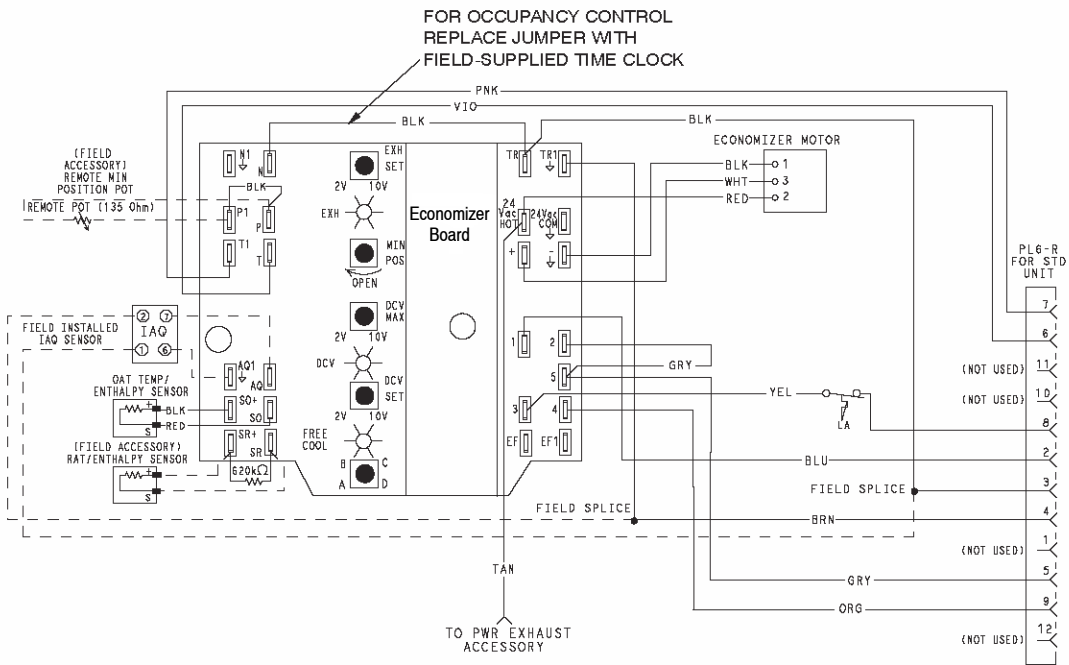

## LEGEND

**DCV**— Demand Controlled Ventilation  
**IAQ** — Indoor Air Quality  
**LA** — Low Ambient Lockout Device  
**OAT** — Outdoor-Air Temperature  
**POT** — Potentiometer  
**RAT** — Return-Air Temperature

## Potentiometer Defaults Settings:

**Power Exhaust** Middle  
**Minimum Pos.** Fully Closed  
**DCV Max.** Middle  
**DCV Set** Middle  
**Enthalpy** C Setting

## NOTES:

1. 620 ohm, 1 watt 5% resistor should be removed only when using differential enthalpy or dry bulb.
2. If a separate field-supplied 24 v transformer is used for the IAQ sensor power supply, it cannot have the secondary of the transformer grounded.
3. For field-installed remote minimum position POT, remove black wire jumper between P and P1 and set control minimum position POT to the minimum position.

TYPICAL WIRING SCHEMATICS (cont.)

CONVENIENCE OUTLET (Optional) PHS036-060

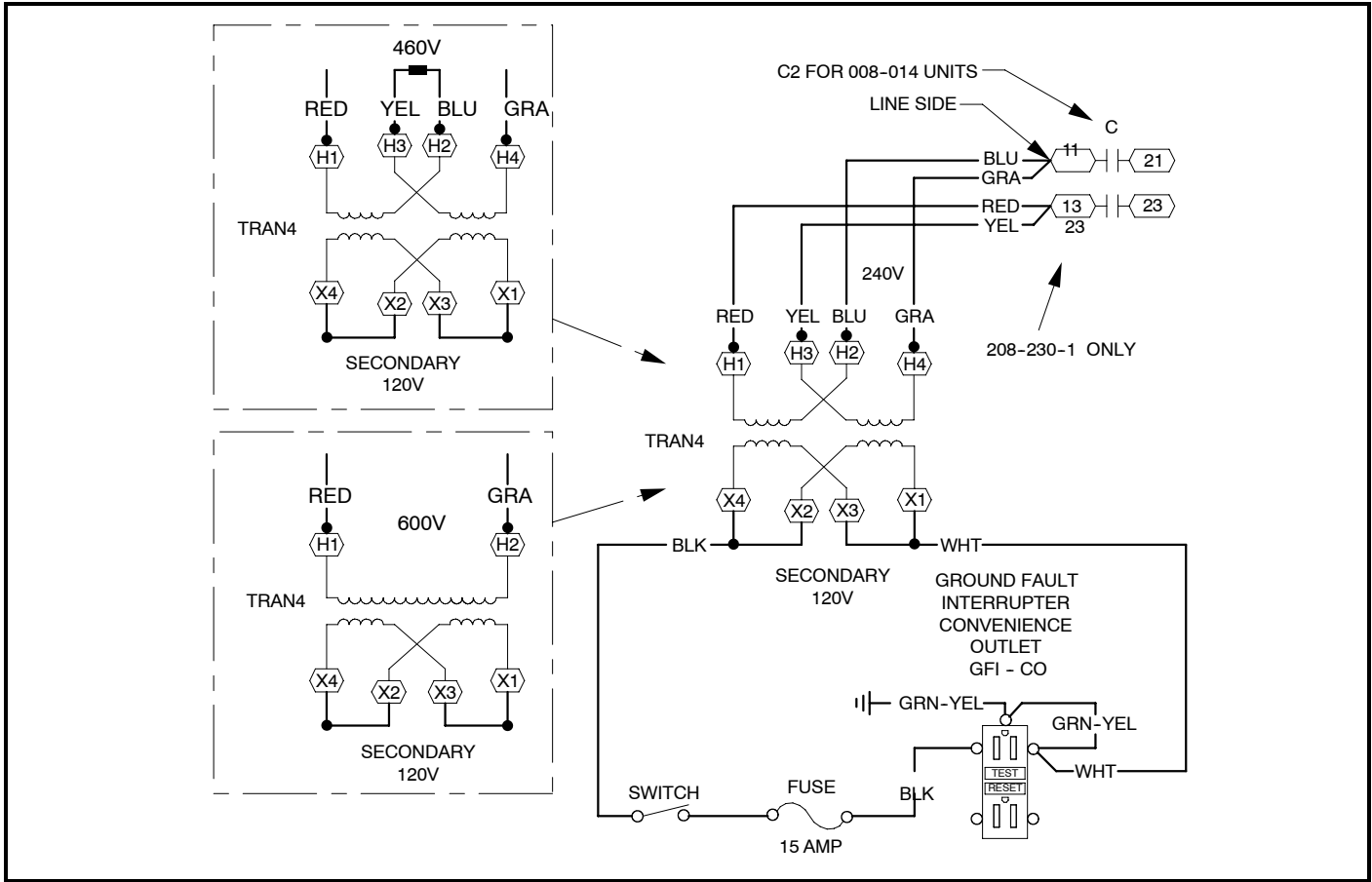

NON-FUSED DISCONNECT - PHS036-060

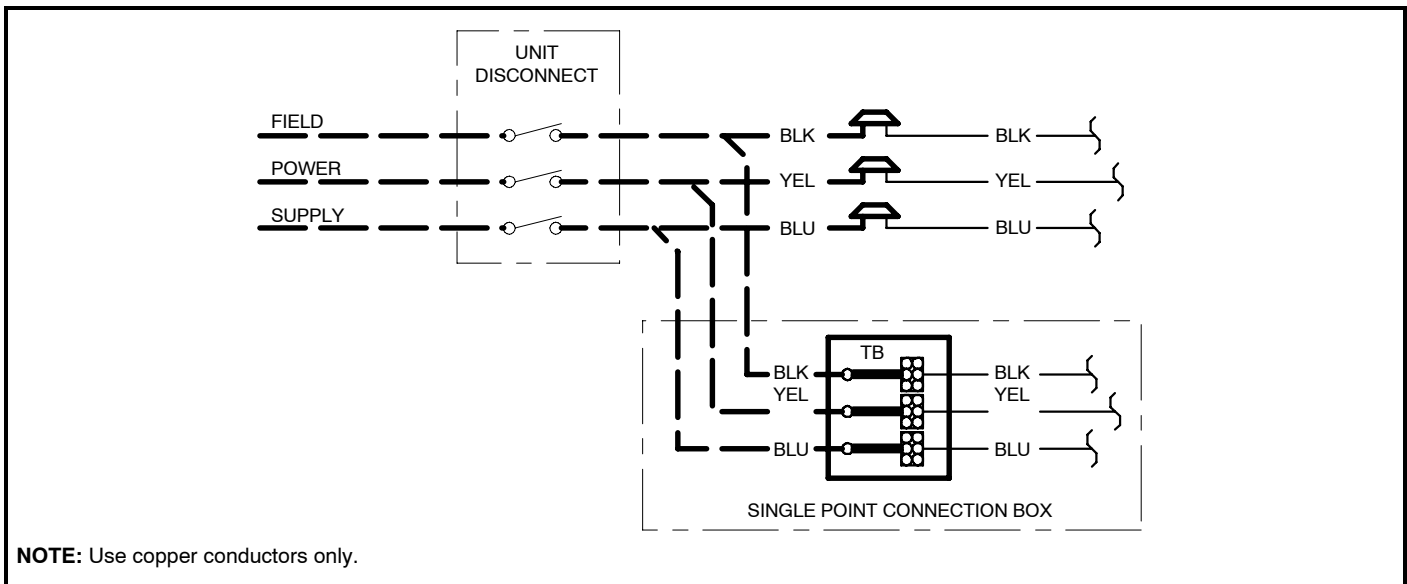

# TYPICAL PIPING AND WIRING

## VERTICAL DISCHARGE DUCTING - PHS

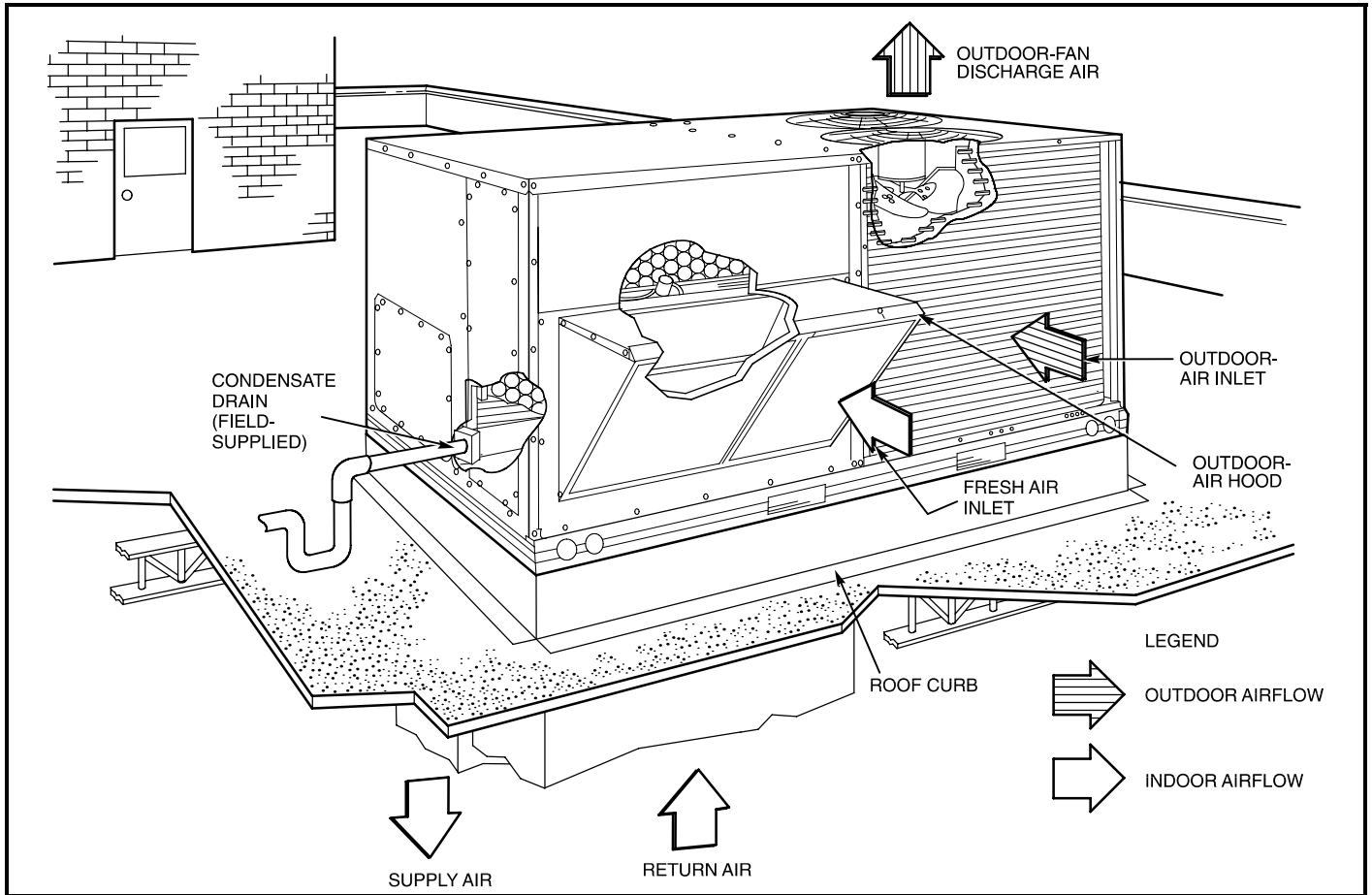

## GUIDE SPECIFICATIONS - PHS036-060

### PACKAGED ROOFTOP HEAT PUMP WITH ELECTRIC HEAT OPTION — CONSTANT VOLUME APPLICATION

#### HVAC GUIDE SPECIFICATIONS

SIZE RANGE: 3 TO 5 TONS, NOMINAL (COOLING)

#### PART 1 — GENERAL

1.01 SYSTEM DESCRIPTION Outdoor rooftop-mounted or slab-mounted, electrically controlled air-to-air heat pump utilizing a hermetic compressor for heating and cooling duty. Unit shall discharge supply air vertically or horizontally.

#### 1.02 QUALITY ASSURANCE

- A. Unit shall be rated in accordance with ARI Standards 210/240 and 270.
- B. Unit shall be designed to conform to ASHRAE 15, latest revision, and in accordance with UL 1995.
- C. Unit shall be UL tested and certified in accordance with ANSI Z21.47 Standard and UL listed and certified under Canadian Standards as a total package for safety requirements.
- D. Roof curb shall be designed to conform to NRCA Standards.
- E. Insulation and adhesive shall meet NFPA 90A requirements for flame spread and smoke generation.
- F. Unit casing shall be capable of withstanding Federal Test Method Standard No. 141 (Method 6061) 500-hour salt spray test.

#### 1.03 DELIVERY, STORAGE, AND HANDLING

Unit(s) shall be stored and handled per manufacturer's recommendations.

#### PART 2 — PRODUCTS

##### 2.01 EQUIPMENT (STANDARD)

###### A. General:

Factory-assembled, single-piece, air-to-air heat pump. Contained within the unit enclosure shall be all factory wiring, piping, controls, refrigerant charge (R-22), and special features required prior to field start-up.

###### B. Unit Cabinet:

1. Unit cabinet shall be constructed of galvanized steel, bonderized and coated with a baked enamel finish on all externally exposed surfaces with primer coated internal panels.
2. Indoor fan cabinet interior shall be insulated with a minimum 1/2-in. thick flexible fiberglass insulation coated on the air side.
3. Cabinet panels shall be easily removable for servicing.
4. Holes shall be provided in the base rails for rigging shackles to facilitate overhead rigging, and forklift slots shall be provided to facilitate maneuvering.
5. Unit shall have a factory-installed, sloped condensate drain pan made of a non-corrosive material, providing a minimum 3/4-in. connection with both vertical and horizontal drains and shall comply with ASHRAE 62.
6. Unit shall have factory-installed filter access panel to provide filter access with tool-less removal.
7. Unit shall have standard thru-the-bottom power connection capability.

###### C. Fans:

1. Indoor blower shall be of the direct-driven or belt-driven, double inlet, forward-curved centrifugal type. Belt drive shall include an adjustable-pitch motor pulley.

2. Indoor blower shall be made from steel with a corrosion-resistant finish and shall be dynamically balanced.
3. Bearings shall be of the sealed, permanently lubricated, ball-bearing type for longer life and lower maintenance.
4. Outdoor fan shall be of the direct-driven propeller type and shall discharge air vertically.
5. Outdoor fan shall have aluminum blades riveted to corrosion-resistant steel spiders and shall be dynamically balanced.

###### D. Compressor(s):

1. Fully hermetic type, internally protected.
2. Factory rubber shock-mounted and internally spring mounted for vibration isolation.

###### E. Coils:

1. Outdoor and indoor coils shall have aluminum plate fins mechanically bonded to enhanced copper tubes with all joints brazed.
2. Tube sheet openings shall be belled to prevent tube wear.
3. Indoor coil shall be of the face split design.
4. Condenser Coils: Copper-fin coils shall be constructed of copper fins mechanically bonded to copper tubes and copper tube sheets. Galvanized steel tube sheets shall not be acceptable. A polymer strip shall prevent coil assembly from contacting the sheet metal coil pan to minimize potential for galvanic corrosion between coil and pan. All copper construction shall provide protection in moderate coastal environments.

###### F. Refrigerant Components: Refrigerant circuit components shall include:

1. Fixed orifice multiple independent circuit metering system.
2. Service gage connections on suction, discharge, and liquid line to charge, evacuate, and contain refrigerant.
3. Accumulator.
4. Reversing valve.

###### G. Filter Section:

1. Standard filter section shall consist of factory-installed low-velocity, throwaway 2-in. thick fiberglass filters of commercially available sizes.
2. Filter face velocity shall not exceed 300 fpm at nominal airflows.
3. Filter section shall use only one size filter.
4. Filters shall be accessible through an access panel with "no-tool" removal.

###### H. Controls and Safeties:

###### 1. Unit Controls:

- a. Unit shall be complete with self-contained low-voltage control circuit.
- b. Unit shall incorporate an outdoor coil defrost system to prevent excessive frost accumulation during heating duty, and shall be controlled as follows:
  - 1) Defrost shall be initiated on the basis of time and coil temperature.
  - 2) A 30/50/90-minute timer shall activate defrost cycle only if coil temperature is low enough to indicate a heavy frost condition.
  - 3) Defrost cycle shall terminate when defrost thermostat is satisfied and shall have a positive termination time of 10 minutes.

c. Unit shall contain high-pressure, loss-of-charge/low-pressure, and freeze protection switches. It shall mount on factory-installed Schrader fittings.

1. Standard Safeties: Unit shall incorporate compressor overtemperature and overcurrent safety devices to shut off compressor.

I. Operating Characteristics:

1. Unit shall be capable of starting and running in cooling at 115°F ambient outdoor temperature, meeting maximum load criteria of ARI Standard 210/240 at  $\pm 10\%$  voltage.
2. Compressor with standard controls shall be capable of cooling operation down to 25°F ambient outdoor temperature.
3. Compressor shall be capable of operation in heating duty down to -10°F ambient outdoor-air temperature.
4. Unit shall be capable of simultaneous heating duty and defrost cycle operation when using electric heaters indicated in Section L, Special Features.

J. Electrical Requirements:

All unit power wiring shall enter unit cabinet at a single factory-predrilled location.

K. Motors:

1. Compressor motors shall be cooled by refrigerant passing through motor windings and shall have line break thermal and current overload protection.
2. Indoor blower motor shall have permanently lubricated bearings and inherent automatic-reset thermal overload protection.
3. Totally enclosed outdoor-fan motor shall have permanently lubricated bearings, and inherent automatic-reset thermal overload protection.

## SEQUENCE OF OPERATION — PHS036–060

**Units Without Economizer** — When thermostat calls for cooling, terminals G and Y1 are energized. The indoor–fan contactor (IFC), reversing valve solenoid and compressor contactor are energized and indoor–fan motor, compressor, and outdoor fan starts. The outdoor–fan motor runs continuously while unit is cooling.

**Heating, Units Without Economizer** — Upon a request for heating from the space thermostat, terminal W1 will be energized with 24 v. The IFC, outdoor–fan contactor (OFC), C1, and C2 will be energized. The indoor fan, outdoor fans, and compressor no. 1, and compressor no. 2 are energized and reversing valves are deenergized and switch position.

If the space temperature continues to fall while W1 is energized, W2 will be energized with 24 v, and the heater contactor(s) (HC) will be energized, which will energize the electric heater(s).

When the space thermostat is satisfied, W2 will be deenergized first, and the electric heater(s) will be deenergized. Upon a further rise in space temperature, W1 will be deenergized.

**Cooling, Units With Economizer** — When free cooling is not available, the compressors will be controlled by the zone thermostat. When free cooling is available, the outdoor–air damper is modulated by the Economizer control to provide a 50° to 55°F mixed–air temperature into the zone. As the mixed–air temperature fluctuates above 55° or below 50°F, the dampers will be modulated (open or close) to bring the mixed–air temperature back within control.

If mechanical cooling is utilized with free cooling, the outdoor–air damper will maintain its current position at the time the compressor is started. If the increase in cooling capacity causes the mixed–air temperature to drop below 45°F, then the outdoor–air damper position will be decreased to the minimum position. If the mixed–air temperature continues to fall, the outdoor–air damper will close. Control returns to normal once the mixed–air temperature rises above 48°F.

If optional power exhaust is installed, as the outdoor–air damper opens and closes, the power exhaust fans will be energized and deenergized.

If field–installed accessory CO<sub>2</sub> sensors are connected to the Economizer control, a demand controlled ventilation strategy will begin to operate. As the CO<sub>2</sub> level in the zone increases above the CO<sub>2</sub> set point, the minimum position of the damper will be increased proportionally. As the CO<sub>2</sub> level decreases because of the increase in fresh air, the outdoor–air damper will be proportionally closed.

For Economizer operation, there must be a thermostat call for the fan (G). If the unit is occupied and the fan is on, the damper will operate at minimum position. Otherwise, the damper will be closed.

When the Economizer control is in the occupied mode and a call for cooling exists (Y1 on the thermostat), the control will first check for indoor fan operation. If the fan is not on, then cooling will not be activated. If the fan is on, then the control will open the Economizer damper to the minimum position.

On the initial power to the Economizer control, it will take the damper up to 2½ minutes before it begins to position itself. Any change in damper position will take up to 30 seconds to initiate. Damper movement from full closed to full open (or vice versa) will take between 1½ and 2½ minutes.

If free cooling can be used as determined from the appropriate changeover command (switch, dry bulb, enthalpy curve, differential dry bulb, or differential enthalpy), then the control will modulate the dampers open to maintain the mixed–air temperature set point at 50 to 55°F.

If there is a further demand for cooling (cooling second stage — Y2 is energized), then the control will bring on compressor stage 1 to maintain the mixed–air temperature set point. The Economizer damper will be open at maximum position. Economizer operation is limited to a single compressor.

**Heating, Units With Economizer** — When the room temperature calls for heat through terminal W1, the indoor (evaporator) fan contactor (IFC) and heater contactor no. 1 (HC1) are energized and the reversing valve(s) deenergize and switches position. On units equipped for 2 stages of heat, when additional heat is needed, heater contactor no. 2 is energized through W2. The economizer damper moves to the minimum position. When the thermostat is satisfied, the damper moves to the fully closed position.

**Defrost** — As frost builds up on the outdoor coil, the coil temperature drops below 28°F. When this outdoor–coil temperature drop is sensed by the defrost thermostat (DFT) and the defrost timer is at the end of a timed period (adjustable at 30, 50, or 90 minutes), the unit operates in a defrost cycle controlled by the defrost timer and thermostat. During this cycle, the reversing valve solenoid (RVS) is energized and the outdoor fan shuts off. The electric heaters (if installed) will be energized.

The unit continues to defrost until the coil temperature as measured by DFT reaches 65°F, or the duration of defrost cycle completes a 10–minute period.

At the end of the defrost cycle, the electric heaters (if installed) and the reversing valve will be deenergized, and the outdoor–fan motor will be energized. The unit will now operate in the Heating mode.

If the thermostat is satisfied during a defrost cycle, the unit will continue in the Defrost mode until the time or temperature constraints are satisfied.

**Automatic Changeover** — When the system selection switch is set at AUTO. position, unit automatically changes from heating operation to cooling operation when the temperature of the conditioned space rises to the cooling level setting. When the temperature of the conditioned space falls to the heating level setting, unit automatically changes from cooling to heating operation (with a 3°F deadband in between).

**Continuous Air Circulation** — Turn unit power on. Set system control at OFF position. Set fan switch at ON position. The indoor–fan contactor is energized through the thermostat switch and the indoor fan runs continuously.

**Compressor Protection** — If unit operation is interrupted by an open high–pressure switch, low–pressure switch, indoor coil freezestat, or by compressor internal line–break device (overcurrent or overtemperature), and compressor is calling for either cooling or heating, the cycle locking protection device simultaneously locks out unit and lights a warning light on the thermostat. Restart the unit by manually turning thermostat to OFF and then to ON position. If any of the protective devices opens again, the unit continues to lock out until corrective action is taken.

**NOTE:** If the unit fails to operate due to compressor overcurrent condition, restart by manually resetting circuit breakers at the unit. Restart cannot be accomplished at the room thermostat.

**Emergency Heat** — If compressor is inoperative due to a tripped safety device (high or low pressure, indoor coil freezestat, overcurrent, or overtemperature), the cycle–locking device locks out the compressor and lights a warning light on the room thermostat. When the switch is on (thermostat is set to the EM HT position), compressor circuit and outdoor thermostats are bypassed, and the second stage of thermostat energizes the indoor blower and the electric resistance heaters.