

ENERGY STAR

3 to 6 Tons

Net Cooling Capacity - 34,800 to 72,000 Btuh

Gas Input Heat Capacity - 65,000 to 150,000 Btuh

MODEL NUMBER IDENTIFICATION

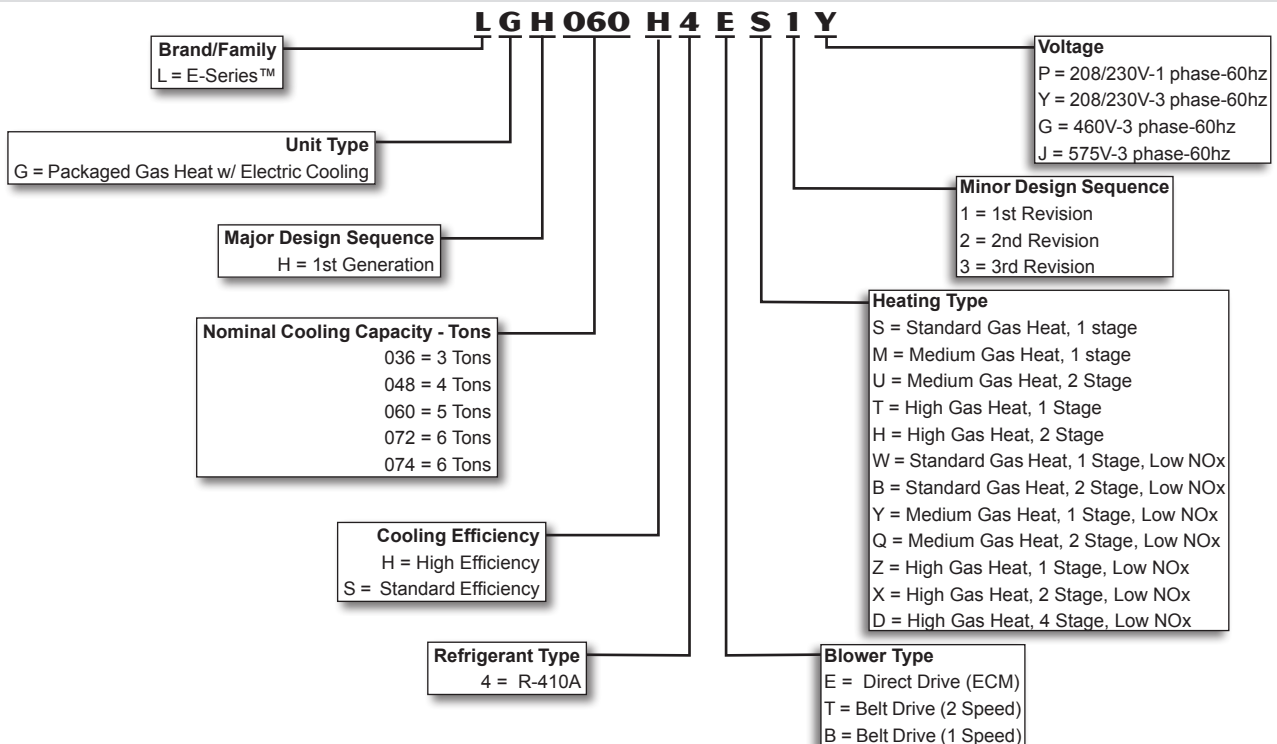

FEATURES AND BENEFITS

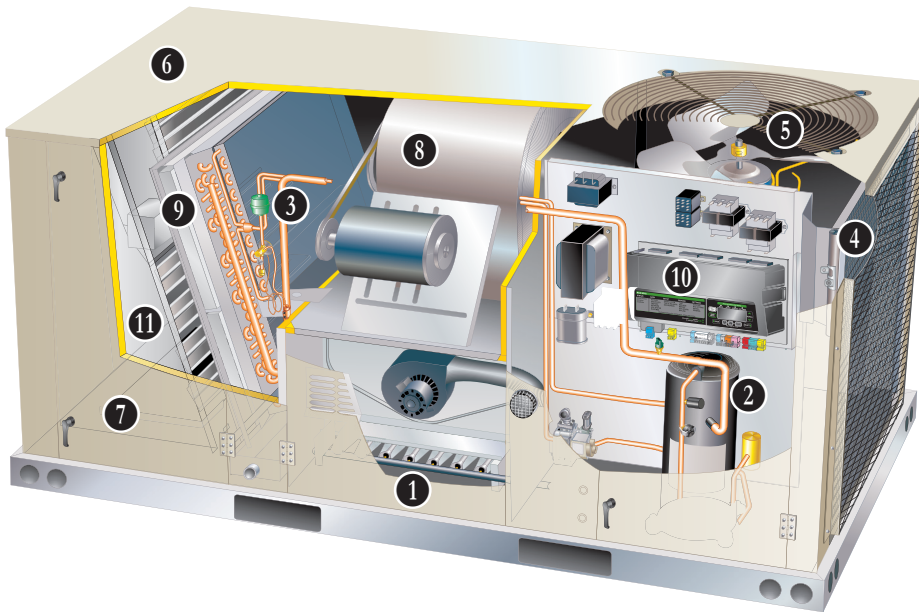

Allied's E-Series™ packaged rooftop unit product line was created to save energy with intelligence by offering some of the highest energy efficiency ratings available with a powerful, easy to use unit controller. This makes E-Series rooftop units perfect for business owners looking for an HVAC product with the lowest total cost of ownership. Allied's E-Series packaged rooftop units feature:

- **ECM Blower And Condenser Fan Motors** - Direct drive units features ECM blower and condenser fan motors to allow energy efficient Single Zone VAV operation during all operating conditions. Blower setpoints can be easily set in the field through the Intelli-Guide™ Unit Controller reducing setup time.
- **Two-Stage Scroll Compressor** - All 3 to 5 ton and 6 ton 074 models feature a two-stage scroll compressor which allows Emergence rooftop units to deliver just the necessary amount of cooling needed to meet the space's demand. Single speed scroll compressor is furnished on 6 ton 072 models.
- **Eco-Last™ Coil System** - Smaller, lighter condenser coil.
- **Hinged Access Panels** - Provide quick access to components and protect panels and roof from damage during servicing.
- **Isolated Compressor Compartment** - Allows performance check during normal compressor operation without disrupting airflow.
- **Corrosion-Resistant Removable, Reversible Drain Pan** - Provides application flexibility, durability and improved serviceability.
- **Thermostatic Expansion Valves** - Provide peak cooling performance across the entire application range.
- **Dehumidification System Option** - Patented system allows for independent control of temperature and humidity, providing enhanced comfort control.
- **MERV 13 Filters** - Available as factory or field option, provide an enhanced level of indoor air quality, and can help the building qualify for additional LEED credits.
- **Foil-Faced Insulation** - Insulation on all internal surfaces that have contact with airflow helps minimize airborne fibers and improve IAQ.
- **Common Components** - Many maintenance items are standard throughout the entire product line, reducing the need to carry different parts to the job or maintain in inventory.

Intelli-Guide™ Control System

Standard on every E-Series™ rooftop unit, the new Intelli-Guide™ unit controller is the heart of the Allied controls offering. The intuitive user interface makes setup, troubleshooting and service easier than ever. Each unit tracks the runtime of every major component and records the date and time when service or maintenance is performed.



WireRight™ System

The WireRight system simplifies field sensor or thermostat installation through advanced connectors that are keyed and color-coded to help prevent miswiring. Not only is the wire coloring scheme standardized across all models, each connection is intuitively labeled to make troubleshooting and servicing quick and easy.

FEATURES AND BENEFITS

CONTENTS

AHRI Data - Heating - 1 Ph Models	22
Blower Data	28
Cooling Ratings	22
Dimensions - Accessories.	50
Dimensions - Unit	49
Electrical Data.	41
Features And Benefits	2
High Altitude Derate	21
Dehumidification System Ratings.	26
Model Number Identification	1
Options / Accessories.	15
Outdoor Sound Data	47
Intelli-Guide™ Control System	7
Sequence Of Operation.	12
Specifications - Belt Drive.	20
Specifications - Direct Drive.	19
Specifications - Standard Gas Heat - Three Phase Models	21
Unit Clearances.	48
Weight Data.	47

APPROVALS

AHRI Certified to AHRI Standard 210/240 (3 thru 5 ton models) and AHRI Standard 340/360 (6 ton models).

ETL and CSA listed.

Efficiency rating certified by CSA.

Components bonded for grounding to meet safety standards for servicing required by UL, ULC and National and Canadian Electrical Codes.

All models are ASHRAE 90.1 compliant.

ENERGY STAR® certified units are designed to use less energy, help save money on utility bills, and help protect the environment.

ISO 9001 Registered Manufacturing Quality System.

WARRANTY

Limited ten years aluminized heat exchanger, limited fifteen years optional stainless steel heat exchanger.

Limited five years on compressors.

Limited three years on the Eco-Last™ Coil System.

Limited three years on Intelli-Guide™ unit controller.

Limited five years optional high performance economizers.

Limited one year all other covered components.

HEATING SYSTEM

- 1 Aluminized steel inshot burners, direct spark ignition, electronic flame sensor, combustion air inducer, redundant automatic single or dual stage gas valve with manual shut-off.

Heat Exchanger

Tubular construction, aluminized steel, life cycle tested.

Stainless Steel Heat Exchanger is required if mixed air temperature is below 45°F.

Limit Controls

Factory installed, redundant limit controls with fixed temperature setting.

Heat limit controls protect heat exchanger and other components from overheating.

Safety Switches

Flame roll-out switch, flame sensor and combustion air inducer proving switch protect system operation.

All safety switches are monitored by the Intelli-Guide™ Unit Controller and diagnostic information is reported and recorded.

Low NOx Models

All models are available in low NOx versions.

Required Selections

Gas Input Choice - Order one:

- Standard Gas Heat (1 Stage) 65,000 Btuh
- Standard Gas Heat (2 Stage) 70,000/53,000 Btuh
- Medium Gas Heat (1 Stage) 108,000 Btuh
- Medium Gas Heat (2 Stage) 81,000/108,000 Btuh
- High Gas Heat (1 Stage) 150,000 Btuh
- High Gas Heat (2 Stage) 113,000/150,000 Btuh
- High Gas Heat (4 Stage) 28,000/81,000/113,000/150,000 Btuh

Standard or Low NOx

Specify standard gas heat or low NOx option.

NOTE - Standard Gas Heat (2 Stage) is only available with low NOx models.

NOTE - High Gas Heat (4 Stage) is only available with LGH060H4E high efficiency, direct drive, Low NOx, models.

FEATURES AND BENEFITS

HEATING SYSTEM (continued)

Options/Accessories

Factory Installed

Stainless Steel Heat Exchanger

Required if mixed air temperature is below 45 °F.

Factory or Field Installed

Low Temperature Vestibule Heater

Extends gas heat operation from -40°F (standard) down to -60°F. Electric heater automatically controls minimum temperature in gas burner compartment when temperature falls below -40°F.

Field Installed

Combustion Air Intake

Extensions

Recommended for use with existing flue extension kits in areas where high snow can block intake air.

LPG/Propane Kits

Conversion kit to field change over units from Natural Gas to LPG/Propane.

Vertical Vent Extension Kit

Use to exhaust flue gases vertically above unit. Required when unit vent is too close to fresh air intakes per building codes. The vent kit also prevents ice formation on intake louvers.

Kit contains vent transition, drain cap and installation hardware.

NOTE - Straight vent pipe (3 in. B-Vent), vent tee and vent cap are not furnished and must be field supplied. Refer to kit instructions for additional information.

COOLING SYSTEM

Designed to maximize sensible and latent cooling performance at design conditions.

System can operate from 0°F to 125°F without any additional controls.

R-410A Refrigerant

Non-chlorine based, ozone friendly, R-410A.

2 Two-Stage Compressor (3 to 5 and 6 Ton 074 Models)

Scroll compressors on all models for high performance, reliability and quiet operation. Two-stage scroll compressors are furnished on 3 to 5 ton and 6 ton 074 models for increased part load efficiency. Single speed scroll furnished on 6 ton 072 models.

Resiliently mounted on rubber grommets for quiet operation.

Compressor Crankcase Heater

Protects against refrigerant migration that can occur during low ambient operation.

Thermal Expansion Valve

Assures optimal performance throughout the application range.

Removable element head.

3 Filter/Drier

High capacity filter/drier protects the system from dirt and moisture.

High Pressure Switch

Protects the compressor from overload conditions such as dirty condenser coils, blocked refrigerant flow, or loss of outdoor fan operation.

Low Pressure Switch

Protects the compressor from low pressure conditions such as low refrigerant charge, or low/no airflow.

Freezestat

Protects the evaporator coil from damaging ice build-up due to conditions such as low/no airflow, or low refrigerant charge.

4 Eco-Last™ Coil System

Condenser coil features lightweight, all aluminum brazed fin construction.

Constructed of three

components: a flat extrusion tube, fins in-between the flat extrusion tube and two refrigerant manifolds.

Eco-Last™ Coil System Features:

- Improved heat transfer performance due to high primary surface area (flat tubes) versus secondary surface (fins).
- Smaller internal volume (reduced refrigerant charge).
- High durability (all aluminum construction).
- Fewer brazed joints.
- Compact design (reduces unit weight).
- Easy maintenance/cleaning.

Face-split design.

Mounting brackets with rubber inserts secure coil to unit providing vibration dampening and corrosion protection.

Evaporator Coil

Copper tube construction, enhanced rippled-edge aluminum fins, flared shoulder tubing connections, silver soldered construction for improved heat transfer. Factory leak tested. Cross row circuiting with rifled tubing optimizes both sensible and latent cooling capacity.

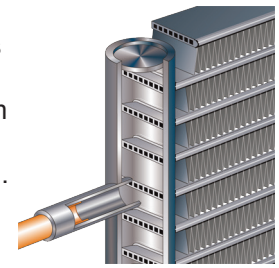

FEATURES AND BENEFITS

COOLING SYSTEM (continued)

Condensate Drain Pan

Plastic pan, sloped to meet drainage requirements of ASHRAE 62.1.

Side or bottom drain connections.

Reversible to allow connection at back of unit.

5 Variable Speed Outdoor Coil Fan Motor (3, 4, 5 Ton High Efficiency models only)

Variable speed (ECM) fan motor for energy efficient Single Zone VAV operation and quiet operation.

Thermal overload protected, totally enclosed, permanently lubricated ball bearings, shaft up, wire basket mount.

Outdoor Coil Fan

PVC coated fan guard furnished.

Required Selections

Cooling Capacity

Specify nominal cooling capacity of the unit.

Cooling Efficiency (3 to 5 Ton models only)

Specify either standard or high efficiency.

Options/Accessories

Factory Installed

Conventional Fin/Tube Condenser Coil (replaces Eco-Last™ Coil System)

Copper tube construction, enhanced rippled-edge aluminum fins, flared shoulder tubing connections, silver soldered construction.

Service Valves

Fully serviceable brass valves installed in discharge & liquid lines.

Not available for units equipped with Eco-Last™ Coil System or Dehumidification Option.

Factory or Field Installed

Condensate Drain Trap

Field installed only, may be factory enclosed to ship with unit.

Available in copper or PVC.

Drain Pan Overflow Switch

Monitors condensate level in drain pan, shuts down unit if drain becomes clogged.

CABINET

6 Construction

Heavy-gauge steel panels and full perimeter heavy-gauge galvanized steel base rail provides structural integrity for transportation, handling, and installation.

Base rails have rigging holes.

Three sides of the base rail have forklift slots.

Raised edges around duct and power entry openings in the bottom of the unit provide additional protection against water entering the building.

Airflow Choice

Units are shipped in downflow (vertical) configuration, can be field converted to horizontal airflow configuration without any optional kits.

Duct Flanges

Provided for horizontal duct attachment.

Power/Gas Entry

Electrical and gas lines can be brought through the unit base or through horizontal access knock-outs.

Exterior Panels

Constructed of heavy-gauge, galvanized steel with a two-layer enamel paint finish.

Insulation

All panels adjacent to conditioned air are fully insulated with non-hygroscopic fiberglass insulation.

Unit base is fully insulated. The insulation also serves as an air seal to the roof curb, eliminating the need to add a seal during installation.

7 Access Panels

Hinged tool-less access panels are provided for the economizer/filter section, and compressor/controls section.

All hinged panels have seals and quarter-turn latching handles to provide a tight air and water seal.

NOTE - Optional Economizers, Power Exhaust, Outdoor Air Dampers and Barometric Relief Dampers for 060/072/074 models include a filler panel for proper cabinet fit.

Required Selections

Airflow Configuration

Specify horizontal or downflow.

Options/Accessories

Factory Installed

Corrosion Protection

A completely flexible immersed coating with an electrodeposited dry film process. (AST ElectroFin E-Coat) Meets Mil Spec MIL-P-53084, ASTM B117 Standard Method Salt Spray Testing.

Indoor Corrosion Protection:

- Coated coil
- Coated reheat coil (Dehumidification)
- Painted blower housing
- Painted base

Outdoor Corrosion Protection:

- Coated coil
- Painted base

Field Installed

Combination Coil/Hail Guards

Heavy gauge steel frame painted to match cabinet with expanded metal mesh to protect the outdoor coil from damage.

FEATURES AND BENEFITS

BLOWER

A wide selection of supply air blower options are available to meet a variety of airflow requirements.

Blower Motor Choice

Overload protected, equipped with ball bearings.

Variable-speed ECM direct drive motors are offered on 036, 048 and 060 models.

Belt drive motors with two-speed capability (low static/high static) are available on 036, 048, 060 and 074 models in several different sizes to maximize air performance.

Single speed belt drive motors are available in different sizes to meet static requirements on 072 models.

8 Supply Air Blower

Forward curved blades, blower wheel is statically and dynamically balanced.

All belt drive motors have adjustable pulley for speed change.

Ordering Information

Specify motor horsepower and drive kit number when base unit is ordered.

Required Selections

Order one drive kit, see Drive Kit Specifications Table.

Options/Accessories

Factory Installed

Blower Belt Auto Tensioner

Provides proper tension to belt drive blower belt without the need for regular adjustments. Maintains airflow and proper performance.

ELECTRICAL

WireRight™ System

Advanced wiring connectors are keyed and color-coded to prevent miswiring. Wire coloring scheme is standardized across all models. Each connection is intuitively labeled to make troubleshooting and servicing quick and easy.

Electrical Plugs

Positive connection electrical plugs are used to connect common accessories or maintenance parts for easy removal or installation.

Required Selections

Voltage Choice

Specify when ordering base unit.

Options/Accessories

Factory Installed

Circuit Breakers

HACR type. For overload and short circuit protection. Factory wired and mounted in the power entry panel. Current sensitive and temperature activated. Manual reset.

Phase/Voltage Detection (3 Phase models only)

Phase detection monitors power supply to assure phase is correct at unit start-up. If phase is incorrect, the unit will not start and an alarm code is reported to the unit controller. Protects unit from being started with incorrect phasing which could lead to issues such as compressors running backwards.

Voltage detection monitors power supply voltage to assure proper voltage. If voltage is not correct (over/under voltage conditions) the unit will not start and an alarm code is reported to the unit controller.

Factory or Field Installed

Disconnect Switch

Accessible from outside of unit, spring loaded weatherproof cover furnished.

GFI Service Outlets (2)

115V ground fault circuit interrupter (GFCI) type, non-powered, field-wired.

INDOOR AIR QUALITY

9 Air Filters

Disposable 2 inch filters furnished as standard.

Options/Accessories

Factory or Field Installed

High Efficiency Air Filters

Disposable MERV 8 or MERV 13 (Minimum Efficiency Reporting Value based on ASHRAE 52.2) efficiency 2 inch pleated filters.

Germicidal Lamps

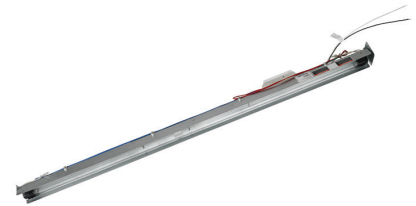

Helps eliminate mold and bacterial growth on the evaporator and drain pans. Improves indoor air quality and maintains efficiency of system by reducing fouling of evaporator coil.

Indoor Air Quality (CO₂) Sensors

Monitors CO₂ levels, reports to the Intelli-Guide™ Unit Controller which adjusts economizer dampers as needed.

INTELLI-GUIDE™ CONTROL SYSTEM

10 INTELLI-GUIDE UNIT CONTROLLER



The Intelli-Guide™ unit controller is a microprocessor-based controller that provides flexible control of all unit functions.

Features:

LCD Display - Easy to read menu with buttons for menu navigation. during setup and diagnostics. 4 lines x 20 character display.

Menu LEDs - Four LEDs (*Data, Setup, Service, Settings*) aid in menu navigation.

Main Menu and Help Buttons - Quick navigation to home screen and built-in help functions.

Scroll, Value Adjustment Select and Save Buttons

Simplified Setup Procedure - SETUP menu insures proper installation and setup of the rooftop unit.

Profile Setup - Copy key settings between units with the same configuration greatly reducing setup time.

USB Port - Allows a technician to download and transfer unit information to help verify service was performed.



USB drive will also allow updating software on the Intelli-Guide Control System to obtain enhanced functionality without the need to change components.

Unit Controller Software

Unit Self-Test - Unit Controller can perform a rooftop unit self-test to verify individual critical component and system performance. Included is an economizer test function that helps assure the economizer is operating correctly.

Time Clock with Run-time Information

Built-In Functions Include:

Adjustable Blower On/Off Delay

Built-in Control Parameter Defaults

Compressor Time-Off Delay

DDC Compatible

Dirty Filter Switch Input

Discharge Air Temperature Control

Display/Sensor Readout

Economizer Control Options - See Economizer / Outdoor Air / Exhaust Options.

Fresh Air Tempering

Extensive Unit Diagnostics - Over 100 diagnostic and status messages in English.

Exhaust Fan Control Modes - Fresh air damper position.

Permanent Diagnostic Code Storage

Field Adjustable Control Parameters - Over 200 different control settings.

Indoor Air Quality Input - Demand Control Ventilation ready

Low Ambient Controls - Cooling operation down to 0°F.

Gas Valve Time Delay Between First and Second Stage

Minimum Compressor Run Time

Network Capable - Can be daisy chained to other units or controls.

Night Setback Mode

Return Air Temperature Limit Control

Safety Switch Input - Allows Controller to respond to a external safety switch trip.

Service Relay Output

Smoke Alarm Mode - Four choices (unit off, positive pressure, negative pressure, purge).

Staging - Up to 2 heat/2 cool (standard Intelli-Guide unit controller thermostat input). Up to 3 cool with additional relay. Up to 4 cool with room sensor or network operation.

“Strike Three” Protection

Gas Reheat Control - Simultaneous heating and cooling operation for controlling humidity for process air applications such as supermarkets.

NOTE - Intelli-Guide Control System features shown vary with the type of rooftop unit the control is installed

On Demand Dehumidification - Monitors and controls condenser hot gas reheat operation with dehumidification option.

Thermostat Bounce Delay

Warm Up Mode Delay

LED Indicators

PC Interface - Connect to the Intelli-Guide unit controller from a PC with the Unit Controller Software.

Room Sensor Operation - Controls temperature.

Options/Accessories

Factory or Field Installed

Blower Proving Switch

Monitors blower operation, shuts down unit if blower fails.

Dirty Filter Switch

Senses static pressure increase indicating dirty filter condition.

Control Options

Factory Installed

Airflow Control System (Available for 3, 4, and 5 Ton High Efficiency Models Equipped With a Direct Drive Blower and Economizer)

Complete airflow management system that precisely controls the economizer damper for accurate ventilation. Allows the installer to directly enter the design-specified supply air (blower) and outdoor air volume (economizer minimum position) parameters without the need to manually take measurements and adjust settings. Also monitors supply air volume and outside air volume as well as customizable diagnostics.

NOTE - Airflow Control is not available on units with the High Gas Heat (4 Stage) option on LGH060H4E high efficiency, direct drive, Low NOx, models.

Factory or Field Installed

Fresh Air Tempering

Used in applications with high outside air requirements. The Controller energizes the first stage heat as needed to maintain a minimum supply air temperature for comfort, regardless of the thermostat demand. When ordered as a factory option, the sensor ships with the unit but must be field installed.

OPTIONS / ACCESSORIES

Controls Options (continued)

Smoke Detector

Photoelectric type, installed in supply air section, return air section or both sections. Available with power board and single sensor (supply or return) or power board and two sensors (supply and return). Power board located in unit control compartment.

Interoperability via BACnet® or LonTalk® Protocols

Communication compatible with third-party automation systems that support the BACnet Application Specific Controller device profile, LonMark® Space Comfort Controller functional profile, or LonMark Discharge Air Controller functional profile.

Commercial Control Systems

Aftermarket DDC

Novar® Unit Controller and options.

Thermostats

Control system and thermostat options. Aftermarket unit controller options.

Field Installed

General Purpose Control Kit

Plug-in control provides additional analog and digital inputs/outputs for field installed options.

Humidity Sensor Kit

Humidity sensor required with factory installed Dehumidification Option or Supermarket reheat field selectable option.

11 ECONOMIZER OPTIONS

Economizer operation is set and controlled by the Intelli-Guide™ Unit Controller.

Simple plug-in connections from economizer to unit controller for easy installation.

All E-Series™ rooftop units are equipped with factory installed CEC Title 24 approved sensors for outside, return and discharge air temperature monitoring.

Optional sensors may be used instead of unit sensors to determine whether outdoor air is suitable for free cooling. See Options/Accessories table.

Factory or Field Installed

Economizer

(Standard and High Performance Common Features)

Outdoor Air Hood is furnished.

Factory installed Economizer can be ordered with three exhaust options:

- Barometric Relief Dampers and Exhaust Hood.
- Power Exhaust Fan (includes Exhaust Hood).
NOTE - See Power Exhaust Fan section for additional requirements.
- No Exhaust.

Field installed Economizer includes Barometric Relief Dampers with Exhaust Hood.

Barometric Relief Dampers allow relief of excess air, aluminum blade dampers prevent blow back and outdoor air infiltration during off cycle, bird screen furnished. Hood is furnished.

Required when Economizer is factory installed with field installed Power Exhaust Fan option. Required (less exhaust hood) when Economizer is factory installed with factory installed Power Exhaust Fan option

Demand Control Ventilation (DCV) ready using optional CO₂ sensors.

Horizontal Economizer Conversion kit is available for field installation.

Standard Economizer Features (Not for Title 24)

Gear-driven action, return air and outdoor air dampers, plug-in connections to unit, neoprene blade edge seals, 24-volt, fully-modulating spring return motor.

NOTE: The Free Cooling default setting for outdoor air temperature sensor is 55°F.

High Performance Economizer Features

Approved for California Title 24 building standards.

Low leakage dampers are Air Movement and Control Association International (AMCA) Class 1A Certified - Maximum 3 CFM per sq. ft. leakage at 1 in. w.g.

ASHRAE 90.1 compliant.

Gear-driven action, high torque 24-volt fully-modulating spring return damper motor, return air and outdoor air dampers, plug-in connections to unit, nylon bearings, enhanced neoprene blade edge seals and flexible stainless steel jamb seals to minimize air leakage.

NOTE - High Performance Economizers are not approved for use with enthalpy controls in Title 24 applications.

NOTE - The Free Cooling setpoint for Title 24 applications must be set based on the Climate Zone where the system is installed. See Section 140.4 "Prescriptive Requirements for Space Conditioning Systems" of the California Energy Commission's 2013 Building Energy Efficiency Standards.

Refer to Installation Instructions for complete setup information.

OPTIONS / ACCESSORIES

ECONOMIZER OPTIONS **(continued)**

Differential Sensible Control

Factory setting. Uses outdoor air and return air sensors that are furnished with the unit. The Intelli-Guide™ unit controller compares outdoor air and return air and using setpoints, enables the economizer when the outdoor air temperature is below the configured setpoint and cooler than return air.

NOTE - Differential Sensible Control can be configured in the field to provide Offset Differential Sensible Control or Single Sensible Control.

In Offset Differential Sensible Control mode, the economizer is enabled if the temperature differential (offset) between outdoor air and return air reaches the configured setpoint.

In Single Sensible Control mode, the economizer is enabled when outdoor air temperature falls below the configured setpoint.

Global Control

The unit controller communicates with a DDC system with one global sensor (enthalpy or sensible) to determine whether outside air is suitable for free cooling on all units connected to the control system. Sensor must be field provided.

NOTE - Global control with enthalpy is not approved for Title 24 applications.

Factory or Field Installed

Single Enthalpy Temperature Control (Not for Title 24)

Outdoor air enthalpy sensor enables Economizer if the outdoor enthalpy is less than the setpoint of the control.

Differential Enthalpy Control (Not for Title 24)

Order two Single Enthalpy Controls. One is field installed in the return air section, the other in the outdoor air section. Allows the economizer control to select between outdoor air or return air, whichever has lower enthalpy.

Field Installed

Building Pressure Control

Maintains constant building pressure level.

Using differential pressure information between the outdoor air and the building air, the Intelli-Guide™ unit controller changes the economizer position to help maintain a constant building pressure.

NOTE - Not available with Demand Control Ventilation (CO₂ Sensor).

Horizontal Economizer Conversion Kit

Insulated panel covers the bottom return air opening on the unit base to convert downflow economizer to horizontal air flow.

EXHAUST OPTIONS

Factory or Field Installed

Power Exhaust Fan

Installs internal to unit for downflow applications with economizer option. Provides exhaust air pressure relief. Interlocked to run when supply air blower is operating, fan runs when outdoor air dampers are 50% open (adjustable), motor is overload protected.

Fan is 16 in. diameter with 4 fan blades and a 1/3 hp motor.

NOTE - If Power Exhaust is field installed with a factory installed Economizer, the Economizer must be ordered with No Exhaust option and Barometric Relief Dampers and Exhaust Hood must also be ordered separately for field installation.

NOTE - If Power Exhaust is factory installed with a factory installed Economizer, the Barometric Relief Dampers without Exhaust Hood must also be ordered separately for field installation.

OUTDOOR AIR OPTIONS

Factory or Field Installed

Outdoor Air Dampers - Downflow or Horizontal

Single blade damper, 0 to 25% (fixed) outdoor air adjustable, installs in unit.

Automatic model features fully modulating spring return damper motor with plug-in connection.

Manual model features a slide damper. Maximum mixed air temperature in cooling mode: 100°F.

Outdoor Air Hood is furnished.

ROOF CURBS

Nailer strip furnished, mates to unit, US National Roofing Contractors Approved, shipped knocked down.

Hybrid Roof Curbs, Downflow

Roof curb can be assembled using interlocking tabs to fasten corners together. No tools required.

Curb can also be fastened together with furnished hardware.

Available in 8, 14, 18, and 24 inch heights.

See Options/Accessories table.

Adjustable Pitch Curb

Fully adjustable pitch curb provides a level platform for rooftop units allowing flexible installations on roofs with uneven or sloped angles.

Maximum slope is 3/4 in. per foot in any direction.

Uses interlocking tabs to fasten corners together. No tools required.

Hardware is furnished to connect upper curb with lower curb.

Available in 14 inch height.

Adaptor Curbs (not shown)

Curbs are regionally sourced. Dimensions will vary based upon the source. Contact your local sales representative for a detailed cut sheet with applicable dimensions.

CEILING DIFFUSERS

Ceiling Diffusers (Flush or Step-Down)

Diffuser face and grilles with white powder coat finish, insulated (UL listed duct liner), diffuser box with collars for duct connection, fixed blades (flush diffusers) and double deflection blades (step-down diffusers), provisions for suspending, internally sealed (prevents recirculation), removable return air grille, adapts to T-bar ceiling grids or plaster ceilings.

Transitions (Supply and Return)

Used with diffusers, installs in roof curb, galvanized steel construction, flanges furnished for duct connection to diffusers, fully insulated.

OPTIONS / ACCESSORIES

DEHUMIDIFICATION SYSTEM

Factory installed option designed to control humidity.

Provides dehumidification on demand using ASHRAE 90.1 recommended method for comfort conditioning humidity control.

Unit comes equipped with one row reheat coil, solenoid valve and humidity controller.

In addition to a thermostat or room sensor used for conventional operation, a humidity sensor is required and must be located in the occupied space. Remote Mounted Humidity Sensor Kit is required for field installation.

The humidity sensor provides input to the Unit Controller which is used to control activation of the dehumidification operation.

Reheat controls are located in the compressor control section of the unit for easy access.

Benefits

Improves indoor air quality.

Helps prevent damage due to high humidity levels.

Improves comfort levels by reducing space humidity levels.

OPERATION

No Dehumidification Demand

The unit will operate conventionally whenever there is a demand for cooling or heating and no dehumidification demand.

Free cooling is only permitted when there is no demand for dehumidification.

Dehumidification Demand Only

The Unit Controller is factory set at 60% relative humidity setpoint and can be adjusted at the Unit Controller or with optional Unit Controller Software.

Reheat operation will initiate on a dehumidification demand and does not require a cooling demand.

The unit will operate in the dehumidification mode until the relative humidity of the conditioned space is below the setpoint.

The reheat coil is sized to provide 68°F to 75°F supply air during reheat operation.

This reduces sensible cooling capacity and extends compressor run time to control humidity when the cooling load is low.

A solenoid valve diverts hot gas from the compressor to the reheat coil.

The cooled and dehumidified air from the evaporator is reheated as it passes through the reheat coil.

The de-superheated and partially condensed refrigerant continues to the outdoor condenser coil where condensing is completed. The unit will continue to operate in this mode until the dehumidification demand is satisfied.

See Sequence of Operation for additional information.

Dehumidification and Cooling Demand (Thermostat/Room Sensor Application)

Two-stage compressor models (036, 048, 060, 074)

If both a dehumidification and a Y1 cooling demand occur, the system will operate in the full cooling mode at first stage indoor air flow. If a Y2 cooling demand occurs along with a dehumidification demand, the system operates in full cooling mode at full cooling airflow until the Y2 cooling demand is satisfied. Then the system will revert to the dehumidification mode if a dehumidification mode demand is present.

Single speed compressor model (072H)

If both a dehumidification and a cooling demand occur, the system will operate in cooling until the cooling demand is satisfied. Then the system will energize the dehumidification mode.

TYPICAL DEHUMIDIFICATION SCHEMATIC

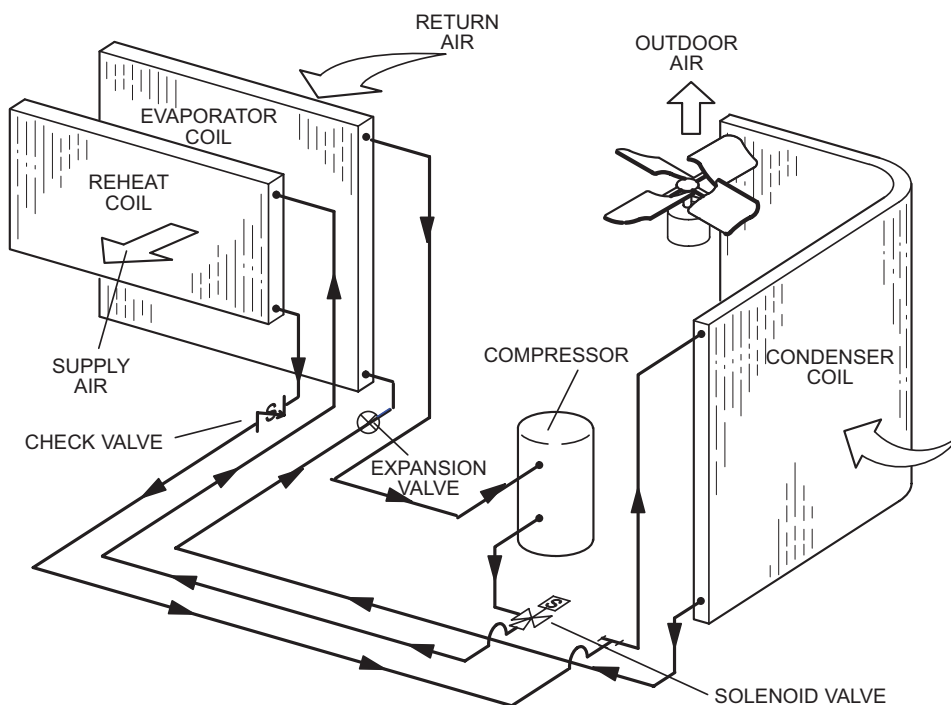

Options/Accessories

Humidity Sensor Kit

Remote Mounted Humidity sensor required with factory installed Dehumidification Option or Supermarket reheat field selectable option.

SEQUENCE OF OPERATION

Objective: Outline the unit functions as a result of room thermostat or zone sensor demands.

Given: When economizer is present, it will function as initial part of the unit cooling system. When not present, unit will function as if outdoor ambient is high and sensed as not suitable.

DIRECT DRIVE AND BELT DRIVE SYSTEM OPERATION (3 THROUGH 5 TONS AND 6 TON 074 MODELS):

Note: Direct drive units feature ECM condenser fans that are staged to match the compressor's capacity. When the compressor is operating at first stage, the condenser fan is operating at low speed. The condenser fan switches to high speed when the compressor switches to second stage to match operation.

Modulating Outdoor Air Damper:

Damper minimum positions #1 and 2 are adjusted during unit setup to provide minimum fresh air requirements at the indicated supply fan speeds per ASHRAE 62.1.

- Supply fan is off and the outdoor air damper is closed
- Supply fan is on low speed and the outdoor air damper is at minimum position 1
- Supply fan is on high speed and the outdoor air damper is at minimum position 2

¹Unit Features an Economizer and Outdoor Air is Suitable

Cooling - Thermostat or Zone Sensor Mode (Up to 3 stages Y1, Y2, Y3)

Y1 demand:

- 1st: Compressor is off, supply fan is on low speed, economizer modulates (minimum to maximum open position) to maintain 55°F supply air temperature (default unit controller setting)
- 2nd: After 5 minutes (default unit controller setting), supply fan switches to high speed. Economizer continues modulating with supply fan on high speed to maintain 55°F supply air temperature

Y2 demand:

- 1st: Compressor is off, supply fan is on high speed, and economizer modulates to maintain 55°F supply air temperature
- 2nd: Economizer opens to maximum. If economizer stays at maximum open for 3 minutes (default unit controller setting) compressor is energized and operates at first stage while supply fan stays on high speed

¹ Outdoor air suitability is determined by the energy state of outdoor ambient (enthalpy or sensible) and its ability to achieve the desired free cooling effects. Outdoor air suitability can also be determined by a third party controller and provided to the RTU via a network connection.

Y3 demand:

- 1st: Economizer is at maximum open and compressor operates at first stage. If economizer stays at maximum open for 3 minutes (default unit controller setting) compressor switches to second stage operation while supply fan stays on high speed

Unit Does not Feature an Economizer (or Outdoor Air Is Not Suitable)

Cooling - Thermostat or Zone Sensor (Up to 2 stages Y1, Y2)

Y1 demand:

- 1st: Compressor operates at first stage and supply fan operates at low speed

Y2 demand:

- 1st: Compressor operates at second stage and supply fan operates at high speed

(Continued on Next Page)

SEQUENCE OF OPERATION

DIRECT DRIVE AND BELT DRIVE SYSTEM OPERATION (3 THROUGH 5 TONS AND 6 TON 074 MODELS) **(Continued):**

Dehumidification Mode (economizer free cooling is locked out):

Unit features the Dehumidification option.

No Y1, Y2 demand but a call for dehumidification:

1st: Compressor operates at second stage, supply fan operates at low speed, and the reheat valve is energized.

Y1 demand:

1st: Compressor operates at second stage, outdoor fan operates at high speed, supply fan operates at low speed and the reheat valve is de-energized.

Y2 demand:

1st: Compressor operates at second stage, supply fan operates at high speed, and the reheat valve is de-energized.

Heating Mode: Thermostat or Zone Sensor (Up to 2 stages W1, W2)

W1 demand:

1st: Gas valve is open (stage 1 on units with 2 stage gas valve) and the supply fan operates at high speed.

W2 demand:

1st: Gas valve is open (stage 2 on units with 2 stage gas valve) and the supply fan operates at high speed.

Heating Mode: Thermostat or Zone Sensor (Up to 4 stages W1, W2) **(LGH060H4E High Efficiency, Direct Drive, Low NOx, Model Only)**

W1 demand:

1st Gas valve is open in low and the supply fan operates at low speed.

After ten minutes the 1st gas valve closes, 2nd Gas valve opens in low and the supply fan operates at low speed.

W2 demand:

1st and 2nd Gas valves open in low and the supply fan operates at high speed.

After ten minutes the 1st and 2nd Gas valves open in high and the supply fan operates at high speed.

If W2 demand is satisfied, but W1 is still present, 1st Gas valve is open in low and the supply fan operates at low speed.

SEQUENCE OF OPERATION

SINGLE STAGE UNIT OPERATION (6 TON 072 MODELS)

Modulating Outdoor Air Damper:

Damper minimum positions are adjusted during unit setup to provide minimum fresh air requirements at the indicated supply fan speeds per ASHRAE 62.1.

- 1) Supply fan is off and the outdoor air damper is closed.
- 2) Supply fan is on and the outdoor air damper is at minimum position.

¹ Unit Features an Economizer and Outdoor Air is Suitable

Cooling - Thermostat or Zone Sensor (Up to 2 stages Y1, Y2).

Y1 demand:

1st: Compressor is off, supply fan is on, economizer modulates (minimum to maximum open position) to maintain 55°F supply air temperature (default unit controller setting).

Y2 demand:

1st: Economizer goes to maximum open position and if the damper stays open for three minutes (default unit controller setting) the compressor is energized.

Unit Does Not Feature an Economizer (or outdoor air is not suitable)

Cooling - Thermostat or Zone Sensor (Up to 1 stage Y1).

Y1 demand:

1st: Compressor is operating and supply fan is on.

Dehumidification Mode (economizer free cooling is locked out):

Unit features the Dehumidification Option.

No Y1 demand but a call for dehumidification:

1st: Compressor is operating, supply fan is on, and the reheat valve is energized.

Y1 demand:

1st: Compressor is operating, supply fan is on, and the reheat valve is de-energized.

Y2 demand:

1st: Compressor is operating, supply fan is on, and the reheat valve is de-energized.

Heating Mode Thermostat or Zone Sensor (Up to 2 stages W1, W2)

W1 demand:

1st: Gas valve is open (stage 1 on units with 2 stage gas valve), supply fan is on.

W2 demand:

1st: Gas valve is open (stage 2 on units with 2 stage gas valve), supply fan is on

OPTIONS / ACCESSORIES

Item	Model Number	Catalog Number	Unit Model Number				
			036	048	060	072	074
COOLING SYSTEM							
Condensate Drain Trap	PVC - C1TRAP20AD2	76W26	OX	OX	OX	OX	OX
	Copper - C1TRAP10AD2	76W27	OX	OX	OX	OX	OX
Conventional Fin/Tube Condenser Coil (replaces Eco-Last™ Coil System)		Factory	O	O	O	O	O
Drain Pan Overflow Switch	E1SNSR71AD1	68W88	OX	OX	OX	OX	OX
Efficiency	Standard	Factory	O	O	O		
	High	Factory	O	O	O	O	O
Service Valves (not for Eco-Last™ Coil System or Dehumidification Option)		Factory	O	O	O	O	O
HEATING SYSTEM							
Bottom Gas Piping Kit	T1GPKT01AN1	19W50	OX	OX	OX	OX	OX
Combustion Air Intake Extensions	T1EXTN10AN1	19W51	X	X	X	X	X
Gas Heat Input	Standard One-Stage - 65 kBtuh input	Factory	O	O	O	O	O
	Standard Two-Stage - 53/70 kBtuh input	Factory	¹ O	¹ O	¹ O	¹ O	¹ O
	Medium One-Stage - 108 kBtuh input	Factory	O	O	O	O	O
	Medium Two Stage - 81/108 kBtuh input	Factory	O	O	O	O	O
	High One-Stage - 150 kBtuh input	Factory		O	O	O	O
	High Two-Stage - 113/150 kBtuh input	Factory		O	O	O	O
	High Four-Stage - 28/81/113/150 kBtuh input	Factory			² O		
Low Temperature Vestibule Heater	208/230V-1 or 3ph - E1LTVH10A-1Y	54W23	OX	OX	OX	OX	OX
	460V-3ph - E1LTVH10A-1G	54W24	OX	OX	OX	OX	OX
	575V-3ph - E1LTVH10A-1J	54W25	OX	OX	OX	OX	OX
LPG/Propane Conversion Kits	For one-stage standard, medium and high models - C1PROP10AP2	14N20	X	X	X	X	X
	For two-stage standard models - C1PROP28A11	21A01	X	X	X	X	X
	For two-stage medium and high models - C1PROP20AP2	14N21	X	X	X	X	X
	For four-stage high models - C1PROP30A11	21A02			X		
Stainless Steel Heat Exchanger		Factory	O	O	O	O	O
Vertical Vent Extension	C1EXTN20FF1	31W62	X	X	X	X	X
BLOWER - SUPPLY AIR							
Motors	Direct Drive - 0.50 hp	Factory	O				
	Direct Drive - 0.75 hp	Factory		O			
	Direct Drive - 1 hp	Factory			O		
	Belt Drive - 0.75 hp (2 Speed)	Factory	O	O			
	Belt Drive - 1 hp (2 Speed)	Factory	O		O		O
	Belt Drive - 2 hp (2 Speed)	Factory		O	O		O
	Belt Drive - 1 hp Standard Efficiency	Factory				O	
	Belt Drive - 2 hp Standard Efficiency	Factory				O	
	Drive Kits			O			
See Blower Data Tables for selection	Kit A01 - T1DRKT001-1 - 673-1010 rpm	Factory	O				
	Kit A02 - T1DRKT002-1 - 745-1117 rpm	Factory		O			
	Kit A03 - T1DRKT003-1 - 833-1250 rpm	Factory			O		
	Kit A05 - T1DRKT005-1 - 897-1346 rpm	Factory	O				
	Kit A06 - T1DRKT006-1 - 1071-1429 rpm	Factory		O			
	Kit A07 - T1DRKT007-1 - 1212-1548 rpm	Factory			O		
	Kit AA01 - T1DRKT001AP1 - 522-784 rpm	Factory				O	O
	Kit AA02 - T1DRKT002AP1 - 632-875 rpm	Factory				O	O
	Kit AA03 - T1DRKT003AP1 - 798-1105 rpm	Factory				O	O
Blower Belt Auto-Tensioner	Factory	O	O	O	O	O	

¹ Standard Two-Stage Heat is only available with Low NOx Models.

² High Four-Stage Heat is only available with LGH060H4E high efficiency, direct drive, Low NOx, models only.

NOTE - Catalog and model numbers shown are for ordering field installed accessories.

OX - Configure To Order (Factory Installed) or Field Installed

O = Configure To Order (Factory Installed)

X = Field Installed

OPTIONS / ACCESSORIES

Item	Model Number	Catalog Number	Unit Model Number				
			036	048	060	072	074
CABINET							
Combination Coil/Hail Guards	C1GARD51A-1	13R98	X	X			
	C1GARD51AT1	13T03			X	X	X
Corrosion Protection (indoor coil / outdoor coil)		Factory	O	O	O	O	O
CONTROLS							
Blower Proving Switch	C1SNSR35FF1	53W65	OX	OX	OX	OX	OX
Commercial Controls Intelli-Guide™ Control System - BACnet® Module - C0CTRL60AE1L Intelli-Guide™ Control System - LonTalk® Module - C0CTRL65FF1 Novar® 2051 - E0CTRL30A1 Novar® LSE	CPC Einstein Integration	Factory	O	O	O	O	OX
		59W51	OX	OX	OX	OX	OX
		54W27	OX	OX	OX	OX	OX
		64W72	OX	OX	OX	OX	OX
		Factory	O	O	O	O	O
Dirty Filter Switch	E1SNSR55AP1	53W66	OX	OX	OX	OX	OX
General Purpose Control Kit	E1GPBK30C1	13J78	X	X	X	X	X
Fresh Air Tempering	C1SNSR75AD1	58W63	OX	OX	OX	OX	OX
¹ Airflow Control System (Supply and Ventilation Airflow Control)		Factory	O	O	O		
Smoke Detector - Supply or Return (Power board and one sensor)	C1SNSR44AP1	53W78	OX	OX	OX	OX	OX
Smoke Detector - Supply and Return (Power board and two sensors)	C1SNSR43AP1	53W79	OX	OX	OX	OX	OX
ELECTRICAL							
Voltage 60 hz	208/230V - 1 phase	Factory	² O	² O	² O		
	208/230V - 3 phase	Factory	O	O	O	O	O
	460V - 3 phase	Factory	O	O	O	O	O
	575V - 3 phase	Factory	O	O	O	O	O
HACR Circuit Breakers		Factory	O	O	O	O	O
Disconnect Switch	80 amp - T1DISC080AH1	20W23	OX	OX			
	80 amp - T1DISC080NH1	20W26			OX	OX	OX
GFI Service Outlets	15 amp non-powered, field-wired (208/230V, 460V only) - LTAGFIK10/15	74M70	OX	OX	OX	OX	OX
	20 amp non-powered, field-wired (575V only) - C1GFICI20FF1	67E01	OX	OX	OX	OX	OX
Weatherproof Cover for GFI	C1GFICI99FF1	10C89	X	X	X	X	X
Phase/Voltage Detection - 3 Phase Models Only		Factory	O	O	O	O	O

¹ Available for 3, 4 and 5 ton high efficiency models equipped with direct drive blower and Economizer.

NOTE - Airflow Control System is not available on units with the High Gas Heat (4 Stage) option on LGH060H4E high efficiency, direct drive, Low NOx, models.

² 208/230-1ph not available on belt drive units.

NOTE - Catalog and model numbers shown are for ordering field installed accessories.

OX - Configure To Order (Factory Installed) or Field Installed

O = Configure To Order (Factory Installed)

X = Field Installed

OPTIONS / ACCESSORIES

Item	Model Number	Catalog Number	Unit Model Number				
			036	048	060	072	074
ECONOMIZER							
Standard Economizer With Outdoor Air Hood (Sensible Control) (Not for Title 24)							
Standard Economizer - Includes Barometric Relief Dampers and Exhaust Hood	E1ECON30A-2-	90W59	OX	OX	OX	OX	OX
Standard Economizer - Includes Barometric Relief Dampers and Exhaust Hood and Power Exhaust		Factory	O	O	O	O	O
Standard Economizer - No Exhaust Option		Factory	O	O	O	O	O
High Performance Economizer With Outdoor Air Hood (Sensible Control) (Approved for California Title 24 Building Standards / AMCA Class 1A Certified)							
High Performance Economizer - Includes Barometric Relief Dampers with Exhaust Hood	E1ECON17A-1	10U54	OX	OX	OX	OX	OX
High Performance Economizer - No Exhaust Option		Factory	O	O	O	O	O
Economizer Accessories							
Horizontal Economizer Conversion Kit	T1HECK00AN1	17W45	X	X	X	X	X
Economizer Controls (Not for Title 24)							
Differential Enthalpy	Order 2 - C1SNSR64FF1	53W64	OX	OX	OX	OX	OX
Sensible Control	Sensor is Furnished	Factory	O	O	O	O	O
Single Enthalpy	C1SNSR64FF1	53W64	OX	OX	OX	OX	OX
Global Control	Sensor Field Provided	Factory	O	O	O	O	O
Building Pressure Control	E1GPBK20C1	13J77	X	X	X	X	X
OUTDOOR AIR							
Outdoor Air Dampers With Outdoor Air Hood							
Motorized	C1DAMP21A-1	15D17	OX	OX	OX	OX	OX
Manual	C1DAMP11A-2	15D18	OX	OX	OX	OX	OX
POWER EXHAUST FAN							
Standard Static	208/230V-1 or 3ph - C1PWRE10A-1P	79W87	OX	OX	OX	OX	OX
<i>Note: Factory installed Power Exhaust Fan includes Exhaust Hood. Barometric Relief Dampers without Exhaust Hood are required (order separately).</i>	460V-3ph - C1PWRE10A-1G	79W88	OX	OX	OX	OX	OX
<i>Note: Field installed Power Exhaust Fans do not include Exhaust Hood. Barometric Relief Dampers with Exhaust Hood are required (order separately).</i>	575V-3ph - C1PWRE10A-1J	79W89	OX	OX	OX	OX	OX
BAROMETRIC RELIEF							
¹ Barometric Relief Dampers with Exhaust Hood	C1DAMP50A-1-	74W38	X	X	X	X	X
² Barometric Relief Dampers without Exhaust Hood	C1DAMP50A-2-	72W89	X	X	X	X	X
CONDENSER REHEAT OPTION							
Dehumidification Option		Factory	O	O	O	O	O
Humidity Sensor Kit, Remote mounted (required)	C0SNSR31AE-1	17M50	X	X	X	X	X

¹ Required when Economizer is factory installed (no exhaust option) with field installed Power Exhaust Fan option.

² Required when Economizer is factory installed with factory installed Power Exhaust Fan option.

NOTE - Catalog and model numbers shown are for ordering field installed accessories.

OX - Configure To Order (Factory Installed) or Field Installed

O = Configure To Order (Factory Installed)

X = Field Installed

OPTIONS / ACCESSORIES

Item	Model Number	Catalog Number	Unit Model Number				
			036	048	060	072	074
INDOOR AIR QUALITY							
Air Filters							
High Efficiency Air Filters Order 4 per unit	MERV 8 (16 x 20 x 2 in.) - C1FLTR15A-1-	54W20	OX	OX			
	MERV 13 (16 x 20 x 2 in.) - T1FLTR40A-1-	52W37	OX	OX			
	MERV 8 (20 x 20 x 2 in.) - C1FLTR15D-1-	54W21			OX	OX	OX
	MERV 13 (20 x 20 x 2 in.) - C1FLTR40D-1-	52W39			OX	OX	OX
Replaceable Media Filter With Metal Mesh Frame (includes non-pleated filter media)	16 x 20 x 2 in. (Order 4) - K1FLTR30A-1	39W09	X	X			
	20 x 20 x 2 in. (Order 4) - K1FLTR30A-2	44N60			X	X	X
Indoor Air Quality (CO₂) Sensors							
Sensor - Wall-mount, off-white plastic cover with LCD display	C0SNSR50AE1L	77N39	X	X	X	X	X
Sensor - Wall-mount, off-white plastic cover, no display	C0SNSR52AE1L	87N53	X	X	X	X	X
Sensor - Black plastic case with LCD display, rated for plenum mounting	C0SNSR51AE1L	87N52	X	X	X	X	X
Sensor - Wall-mount, black plastic case, no display, rated for plenum mounting	C0MISC19AE1	87N54	X	X	X	X	X
CO ₂ Sensor Duct Mounting Kit - for downflow applications	C0MISC19AE1-	85L43	X	X	X	X	X
Aspiration Box - for duct mounting non-plenum rated CO ₂ sensors (87N53 or 77N39)	C0MISC16AE1-	90N43	X	X	X	X	X
UVC Germicidal Lamps							
¹ UVC Light Kit (208/230v-1ph)	C1UVCL10AN1-	50W90	OX	OX	OX	OX	OX
ROOF CURBS							
Hybrid Roof Curbs, Downflow							
8 in. height	C1CURB70A-1	11F50	X	X	X	X	X
14 in. height	C1CURB71A-1	11F51	X	X	X	X	X
18 in. height	C1CURB72A-1	11F52	X	X	X	X	X
24 in. height	C1CURB73A-1	11F53	X	X	X	X	X
Adjustable Pitched Curb							
14 in. height	C1CURB55AT1	43W27	X	X	X	X	X
Transition Curb							
CEILING DIFFUSERS							
Step-Down - Order one	RTD9-65S	13K60	X	X	X		
	RTD11-95S	13K61				X	X
Flush - Order one	FD9-65S	13K55	X	X	X		
	FD11-95S	13K56				X	X
Transitions (Supply and Return) - Order one	T1TRAN10AN1	17W53	X	X	X		
	T1TRAN20N-1	17W54				X	X

¹ Lamps operate on 110-230V single-phase power supply. Step-down transformer may be ordered separately for 460V and 575V units. Alternately, 110V power supply may be used to directly power the UVC ballast(s).

NOTE - Catalog and model numbers shown are for ordering field installed accessories.

OX - Configure To Order (Factory Installed) or Field Installed

O = Configure To Order (Factory Installed)

X = Field Installed

SPECIFICATIONS - DIRECT DRIVE

General Data		Nominal Tonnage	3 Ton	4 Ton	5 Ton
		Model Number	LGH036H4E	LGH048H4E	LGH060H4E
		Efficiency Type	High	High	High
		Blower Type	Multi-Speed Direct Drive	Multi-Speed Direct Drive	Multi-Speed Direct Drive
Cooling Performance	Gross Cooling Capacity - Btuh		36,600	50,100	61,600
	¹ Net Cooling Capacity - Btuh		36,000	49,000	60,000
	AHRI Rated Air Flow - cfm		1200	1600	1750
	Total Unit Power - kW		2.8	3.8	4.7
	¹ SEER (Btuh/Watt) - 208/230V-1ph, 3ph		18.0	17.6	17.1
	¹ SEER (Btuh/Watt) - 460V-3ph, 575V-3ph		17.0	17.0	17.0
	¹ EER (Btuh/Watt) - 208/230V-1ph, 3ph		12.8	12.8	12.7
¹ EER (Btuh/Watt) - 460V-3ph, 575V-3ph		12.5	12.8	12.7	
AHRI Reference No. (also see page 22 for AHRI Heating)	208/230V-1 ph		N/A	N/A	N/A
	208/230V-3 ph		N/A	N/A	N/A
	460V-3 ph		N/A	N/A	N/A
	575V-3 ph		N/A	N/A	N/A
Refrigerant Charge	Refrigerant Type		R-410A	R-410A	R-410A
	Eco-Last™ Coil System		4 lbs. 5 oz.	6 lbs. 4 oz.	8 lbs. 0 oz.
	Conventional Fin/Tube Coil		8 lbs. 8 oz.	11 lbs. 2 oz.	14 lbs. 0 oz.
	Eco-Last™ Coil System With Dehumidification		5 lbs. 2 oz.	6 lbs. 8 oz.	8 lbs. 0 oz.
	Conventional Fin/Tube With Dehumidification		9 lbs. 3 oz.	12 lbs. 4 oz.	16 lbs. 0 oz.
Gas Heating Options Available - See page 21			Standard (1 or 2 stage), Medium (1 or 2 stage)	Standard (1 or 2 stage), Medium (1 or 2 stage), High (1 or 2 stage)	Standard (1 or 2 stage), Medium (1 or 2 stage), High (1, 2 or 4 Stage)
Compressor Type (one per unit)			Two-Stage Scroll	Two-Stage Scroll	Two-Stage Scroll
Outdoor Coil Eco-Last™ (Fin/Tube)	Net face area (total) - sq. ft.		11.70 (15.60)	14.50 (15.60)	17.80 (19.30)
	Tube diameter - in.		0.71 (3/8)	0.71 (3/8)	0.71 (3/8)
	Number of rows		1 (1.5)	1 (2)	1 (2)
	Fins per inch		20 (20)	20 (20)	20 (20)
Outdoor Coil Fans	Motor - (No.) horsepower		(1) 1/3 (ECM)	(1) 1/3 (ECM)	(1) 1/3 (ECM)
	Motor rpm		715-810	645-810	930-1100
	Total Motor Input - watts		112-160	89-165	230-350
	Diameter - (No.) in.		(1) 24	(1) 24	(1) 24
	Number of blades		3	3	3
	Total air volume - cfm		3400-3795	2910-3675	4315-4980
Indoor Coil	Net face area (total) - sq. ft.		7.78	7.78	9.72
	Tube diameter - in.		3/8	3/8	3/8
	Number of rows		3	4	4
	Fins per inch		14	14	14
	Drain connection (Number) and size - in.		(1) 1 NPT	(1) 1 NPT	(1) 1 NPT
	Expansion device type		Balanced Port Thermostatic Expansion Valve, removable power head		
² Indoor Blower	Nominal motor HP		0.50 (ECM)	0.75 (ECM)	1 (ECM)
	Blower wheel nominal diameter x width - in.		(1) 10 X 10	(1) 10 X 10	(1) 11 X 10
Filters	Type of filter		disposable		
	Number and size - in.		(4) 16 X 20 X 2		(4) 20 x 20 x 2
Electrical characteristics			208/230V - 60 hz - 1 phase 208/230V, 460V, or 575V - 60 hz -3 phase		

NOTE - Net capacity includes evaporator blower motor heat deduction. Gross capacity does not include evaporator blower motor heat deduction.

¹ AHRI Certified to AHRI Standard 210/240: 95°F outdoor air temperature and 80°F db/67°F wb entering evaporator air; minimum external duct static pressure.

² Using total air volume and system static pressure requirements determine from blower performance tables rpm and motor output required. Maximum usable output of motors furnished are shown. In Canada, nominal motor output is also maximum usable motor output. If motors of comparable output are used, be sure to keep within the service factor limitations outlined on the motor nameplate.

SPECIFICATIONS - BELT DRIVE

General Data		Nominal Tonnage	3 Ton	4 Ton	5 Ton	6 Ton	6 Ton
		Model Number	LGH036S4T	LGH048S4T	LGH060S4T	LGH072H4B	LGH074H4T
		Efficiency Type	Standard	Standard	Standard	High	High
		Blower Type	Two Speed Belt Drive	Two Speed Belt Drive	Two Speed Belt Drive	Single Speed Belt Drive	Two Speed Belt Drive
Cooling Performance	Gross Cooling Capacity - Btuh		35,800	49,100	61,600	73,500	72,000
	Net Cooling Capacity - Btuh		¹ 34,800	¹ 48,000	¹ 60,000	² 72,000	² 69,000
	AHRI Rated Air Flow - cfm		1200	1600	1750	1920	2100
	Total Unit Power - kW		3.0	3.9	4.8	6.0	5.7
	SEER (Btuh/Watt)		¹ 15.0	¹ 15.0	¹ 15.5	---	---
	EER (Btuh/Watt)		¹ 11.6	¹ 11.6	¹ 12.3	² 12.0	² 12.0
	IEER (Btuh/Watt)		---	---	---	² 13.5	² 16.0
AHRI Reference No.	208/230V-3 ph		N/A	N/A	N/A	---	---
	460V-3 ph		N/A	N/A	N/A	---	---
	575V-3 ph		N/A	N/A	N/A	---	---
	All voltages		---	---	---	N/A	N/A
Refrigerant Charge	Refrigerant Type		R-410A	R-410A	R-410A	R-410A	R-410A
	Eco-Last™ Coil System		4 lbs. 5 oz.	6 lbs. 4 oz.	8 lbs. 0 oz.	7 lbs. 8 oz.	7 lbs. 2 oz.
	Conventional Fin/Tube Coil		8 lbs. 8 oz.	11 lbs. 2 oz.	14 lbs. 0 oz.	13 lbs. 12 oz.	13 lbs. 11oz
	Eco-Last™ Coil System With Dehumidification		5 lbs. 2 oz.	6 lbs. 8 oz.	8 lbs. 0 oz.	9 lbs. 0 oz.	8 lbs. 15 oz.
	Conventional Fin/Tube With Dehumidification		9 lbs. 3 oz.	12 lbs. 4 oz.	16 lbs. 0 oz.	15 lbs. 3 oz.	15 lbs. 11oz
Gas Heating Options Available - See page 21			Standard (1 or 2 stage), Medium (1 or 2 stage)	Standard (1 or 2 stage), Medium (1 or 2 stage), High (1 or 2 stage)	Standard (1 or 2 stage), Medium (1 or 2 stage), High (1 or 2 stage)	Standard (1 or 2 stage), Medium (1 or 2 stage), High (1 or 2 stage)	Standard (1 or 2 stage), Medium (1 or 2 stage), High (1 or 2 stage)
Compressor Type (one per unit)			Two-Stage Scroll	Two-Stage Scroll	Two-Stage Scroll	Scroll	Two-Stage Scroll
Outdoor Coil Eco-Last™ (Fin/Tube)	Net face area (total) - sq. ft.		11.70 (15.60)	14.5 (15.60)	17.80 (19.30)	17.80 (19.30)	17.80 (19.30)
	Tube diameter - in.		0.71 (3/8)	0.71 (3/8)	0.71 (3/8)	0.71 (3/8)	0.71 (3/8)
	Number of rows		1 (1.5)	1 (2)	1 (2)	1 (2)	1 (2)
	Fins per inch		20 (20)	20 (20)	20 (20)	20 (20)	20 (20)
Outdoor Coil Fans	Motor - (No.) horsepower		(1) 1/6 (PSC)	(1) 1/4 (PSC)	(1) 1/3 (PSC)	(1) 1/3 (PSC)	(1) 1/3 (PSC)
	Motor rpm		825	825	1075	1075	1075
	Total Motor Input - watts		168	230	410	410	375
	Diameter - (No.) in.		(1) 24	(1) 24	(1) 24	(1) 24	(1) 24
	Number of blades		3	3	3	3	3
	Total air volume - cfm		3000	3300	4800	4800	4800
Indoor Coil	Net face area (total) - sq. ft.		7.78	7.78	9.72	9.72	9.72
	Tube diameter - in.		3/8	3/8	3/8	3/8	3/8
	Number of rows		3	4	4	4	4
	Fins per inch		14	14	14	14	14
	Drain connection (Number) and size - in.		(1) 1 NPT	(1) 1 NPT	(1) 1 NPT	(1) 1 NPT	(1) 1 NPT
	Expansion device type		Balanced Port Thermostatic Expansion Valve, removable power head				
³ Indoor Blower and Drive Selection	No. of Speeds		2	2	2	1	2
	Nominal motor HP	Low static	0.75	0.75	1	1	1
		High static	1	2	2	2	2
	Maximum usable motor output (US)	Low static	0.86	0.86	1.15	1.15	1.15
		High static	1.15	2.3	2.3	2.30	2.30
	Motor - Drive kit number		A01	A02	A03	AA01	AA01
		low	449-673	497-673	555-833	522 - 784 rpm	522 - 784 rpm
		high	673-1010	745-1117	833-1250	AA02	AA02
		A05	A06	A07	632 - 875 rpm	632 - 875 rpm	
	low	598-897	714-953	808-1032	AA03	AA03	
	high	897-1346	1071-1429	1212-1548	798 - 1105 rpm	798 - 1105 rpm	
Blower wheel nominal diameter x width - in.		(1) 10 X 10	(1) 10 X 10	(1) 10 X 10	(1) 15 X 9	(1) 15 X 9	
Filters	Type of filter		disposable				
	Number and size - in.		(4) 16 X 20 X 2		(4) 20 X 20 X 2		
Electrical characteristics			208/230V, 460V, or 575V - 60 Hz -3 phase				

NOTE - Net capacity includes evaporator blower motor heat deduction. Gross capacity does not include evaporator blower motor heat deduction.

^{1,2}AHRI Certified to AHRI Standard ¹ 210/240 or ² 340/360: 95°F outdoor air temperature and 80°F db/67°F wb entering evaporator air; minimum external duct static pressure.

³ Using total air volume and system static pressure requirements determine from blower performance tables rpm and motor output required. Maximum usable output of motors furnished are shown. In Canada, nominal motor output is also maximum usable motor output. If motors of comparable output are used, be sure to keep within the service factor limitations outlined on the motor nameplate.

SPECIFICATIONS - STANDARD GAS HEAT - THREE PHASE MODELS

Model No.	036 048 060	072 074	036 048 060	072 074	036 048 060	072 074	048 060	072 074	048 060	072 074
Heat Input Type	Standard (1 Stage)		Medium (1 Stage)		Medium (2 Stage)		High (1 Stage)		High (2 Stage)	
Input Btuh	65,000		108,000		81,000		150,000		113,000	
1st Stage	---		---		108,000		---		150,000	
2nd Stage	52,000		86,000		65,000		120,000		90,000	
3rd Stage	---		---		86,000		---		120,000	
Temperature Rise Range - °F	15-45	5-35	30-70	15-45	25-55	10-40	45-75	25-55	30-60	15-45
1st stage	---		---		30-70	15-45	---		45-75	25-55
2nd Stage	80%		80%		80%		80%		80%	
¹ Thermal Efficiency										
Gas Supply Connections	1/2 in. NPT									
Rec. Gas Supply Pressure - Nat./ LPG	7 in.w.g. / 11 in.w.g.									

¹ Thermal Efficiency at full input.

SPECIFICATIONS - LOW NOX GAS HEAT - SINGLE AND THREE PHASE MODELS

Model No.	036 048 060	072 074	036 , 048 060 , 072 074	036 048 060	072 074	036 048 060	072 074	048 060	072 074	048 060	072 074	060
Heat Input Type	Standard (1 Stage)		³ Standard (2 Stage) Low NOx only	Medium (1 Stage)		Medium (2 Stage)		High (1 Stage)		High (2 Stage)		^{4, 5} High (4 Stage) Low NOx only
Input Btuh	65,000		53,000	108,000		81,000		150,000		113,000		28,000
1st Stage	---		70,000	---		108,000		---		150,000		81,000
2nd Stage	---		---	---		---		---		---		113,000
3rd Stage	---		---	---		---		---		---		150,000
4th Stage	52,000		43,000	87,000		66,000		121,000		92,000		22,000
Output Btuh	---		57,000	---		87,000		---		121,000		66,000
1st Stage	---		---	---		---		---		---		92,000
2nd Stage	---		---	---		---		---		---		121,000
3rd Stage	---		---	---		---		---		---		92,000
4th Stage	---		---	---		---		---		---		121,000
Temperature Rise Range - °F	15-45	5-35	5-35	30-70	15-45	25-55	10-40	45-75	25-55	30-60	15-45	5-35
1st stage	---		15-45	---		30-70	15-45	---		45-75	25-55	35-65
2nd Stage	---		---	---		---	---	---		---	---	35-65
3rd Stage	---		---	---		---	---	---		---	---	45-75
4th Stage	81%		81%	81%		81%		81%		81%		81%
¹ AFUE (Single Phase)	81%		81%	81%		81%		81%		81%		81%
² Thermal Efficiency (Three Phase)												
Gas Supply Connections	1/2 in. NPT											
Rec. Gas Supply Pressure - Nat./ LPG	7 in.w.g. / 11 in.w.g.											

¹ Annual Fuel Utilization Efficiency based on U.S. DOE test procedures and FTC labeling regulations.

² Thermal Efficiency at full input.

³ Two-Stage Standard Heat is only available with Low NOx Models.

⁴ Four-Stage High Heat is only available with LGH060H4E high efficiency, direct drive, Low NOx, models only.

⁵ Stainless Steel Heat Exchanger is furnished as Standard when Four-Stage Heat is Ordered.

HIGH ALTITUDE DERATE

<p>NOTE - Units may be installed at altitudes up to 2000 ft. above sea level without any modifications. At altitudes above 2000 ft. units must be derated to match information in the table shown. At altitudes above 4500 ft. unit must be derated 2% for each 1000 ft. above sea level.</p> <p>NOTE - This is the only permissible derate for these units.</p>	Heat Input Type	Altitude Feet	Gas Manifold Pressure in. w.g.		Input Rate (Btuh)	
				Natural Gas	LPG/ Propane	
	Standard (1 stage)	2001 - 4500	3.0	9.0	60,000	
	Standard (2 stage)	2001 - 4500	3.0/1.7	9.0/5.1	65,000 / 49,000	
	Medium (1 stage)	2001 - 4500	3.0	9.0	100,000	
	Medium (2 stage)	2001 - 4500	3.0/1.7	9.0/5.1	100,000 / 75,000	
	High (1 stage)	2001 - 4500	3.0	9.0	139,000	
	High (2 stage)	2001 - 4500	3.0/1.7	9.0/5.1	139,000 / 104,000	
High (4 stage)	2001 - 4500	3.0/1.7	9.0/5.1	139,000 / 104,000 / 75,000 / 26,000		

AHRI DATA - HEATING - 1 PH MODELS

Model Number (Drive Type)	¹ Type	Gas Heat Size (All Low NOx)	AHRI Reference Number
LGH036 (Direct)	W	Standard, 1 Stage	8203440
	B	Standard, 2 Stage	8992679
	Y	Medium, 1 Stage	8203441
	Q	Medium, 2 Stage	8203439
LGH048 (Direct)	W	Standard, 1 Stage	8203443
	B	Standard, 2 Stage	8992680
	Y	Medium, 1 Stage	8203446
	Q	Medium, 2 Stage	8203442
	Z	High, 1 Stage	8203447
	X	High, 2 Stage	8203444

NOTE - All models are 208/230V-1 phase-60hz only.

¹ Model Number Heat Designation.

AHRI DATA - HEATING - 1 PH MODELS

Model Number (Drive Type)	¹ Type	Gas Heat Size (All Low NOx)	AHRI Reference Number
LGH060 (Direct)	W	Standard, 1 Stage	8203449
	B	Standard, 2 Stage	8992682
	D	Standard, 4 Stage	8992683
	Y	Medium, 1 Stage	8203452
	Q	Medium, 2 Stage	8203448
	Z	High, 1 Stage	8203453
	X	High, 2 Stage	8203450

NOTE - All models are 208/230V-1 phase-60hz only.

¹ Model Number Heat Designation.

COOLING RATINGS

NOTE - For Temperatures and Capacities not shown in tables, see bulletin - Cooling Unit Rating Table Correction Factor Data in Miscellaneous Product Data section.

3 TON STANDARD EFFICIENCY LGH036S4 (1ST STAGE)

Entering Wet Bulb Temperature	Total Air Volume	Outdoor Air Temperature Entering Outdoor Coil																							
		65°F						75°F						85°F						95°F					
		Total Cool Cap.	Comp. Motor Input	Sensible To Total Ratio (S/T)			Total Cool Cap.	Comp. Motor Input	Sensible To Total Ratio (S/T)			Total Cool Cap.	Comp. Motor Input	Sensible To Total Ratio (S/T)			Total Cool Cap.	Comp. Motor Input	Sensible To Total Ratio (S/T)						
				Dry Bulb					Dry Bulb					Dry Bulb					Dry Bulb						
cfm	kBtuh	kW	75°F	80°F	85°F	kBtuh	kW	75°F	80°F	85°F	kBtuh	kW	75°F	80°F	85°F	kBtuh	kW	75°F	80°F	85°F					
63°F	640	26.1	1.02	0.68	0.81	0.95	25.2	1.18	0.68	0.82	0.97	24.1	1.36	0.7	0.84	0.99	23	1.57	0.71	0.87	1				
	800	27.6	1.01	0.72	0.88	1	26.6	1.17	0.73	0.91	1	25.4	1.35	0.75	0.93	1	24.2	1.56	0.77	0.96	1				
	960	28.8	1	0.77	0.96	1	27.7	1.16	0.78	0.98	1	26.5	1.34	0.81	1	1	25.3	1.54	0.83	1	1				
67°F	640	27.7	1.01	0.54	0.65	0.76	26.7	1.17	0.54	0.66	0.78	25.6	1.35	0.55	0.67	0.8	24.3	1.55	0.56	0.69	0.82				
	800	29.2	1	0.56	0.7	0.84	28.1	1.16	0.57	0.71	0.86	26.9	1.34	0.58	0.72	0.89	25.6	1.54	0.59	0.74	0.92				
	960	30.3	0.99	0.59	0.74	0.92	29.2	1.15	0.6	0.76	0.94	27.8	1.33	0.61	0.78	0.97	26.4	1.53	0.62	0.81	1				
71°F	640	29.2	1	0.42	0.52	0.63	28.1	1.16	0.42	0.53	0.64	27	1.34	0.42	0.53	0.65	25.7	1.54	0.42	0.55	0.66				
	800	30.8	0.98	0.43	0.55	0.67	29.7	1.14	0.43	0.55	0.68	28.4	1.32	0.43	0.57	0.7	27	1.53	0.44	0.58	0.72				
	960	32.1	0.97	0.44	0.58	0.72	30.8	1.13	0.44	0.59	0.73	29.4	1.31	0.44	0.6	0.75	28	1.51	0.45	0.61	0.78				

3 TON STANDARD EFFICIENCY LGH036S4 (2ND STAGE)

Entering Wet Bulb Temperature	Total Air Volume	Outdoor Air Temperature Entering Outdoor Coil																			
		85°F					95°F					105°F					115°F				
		Total Cool Cap.	Comp. Motor Input	Sensible To Total Ratio (S/T)			Total Cool Cap.	Comp. Motor Input	Sensible To Total Ratio (S/T)			Total Cool Cap.	Comp. Motor Input	Sensible To Total Ratio (S/T)			Total Cool Cap.	Comp. Motor Input	Sensible To Total Ratio (S/T)		
				Dry Bulb					Dry Bulb					Dry Bulb					Dry Bulb		
cfm	kBtuh	kW	75°F	80°F	85°F	kBtuh	kW	75°F	80°F	85°F	kBtuh	kW	75°F	80°F	85°F	kBtuh	kW	75°F	80°F	85°F	
63°F	960	34.1	2.21	0.71	0.85	0.99	32.4	2.48	0.73	0.87	1	30.8	2.79	0.74	0.9	1	28.9	3.15	0.76	0.94	1
	1200	35.7	2.23	0.77	0.94	1	34.1	2.5	0.78	0.96	1	32.3	2.82	0.81	0.99	1	30.4	3.18	0.83	1	1
	1440	37	2.25	0.82	1	1	35.5	2.52	0.84	1	1	33.8	2.84	0.87	1	1	31.9	3.2	0.91	1	1
67°F	960	35.9	2.24	0.56	0.69	0.82	34.3	2.51	0.57	0.7	0.84	32.5	2.82	0.58	0.72	0.87	30.5	3.18	0.59	0.74	0.9
	1200	37.6	2.26	0.6	0.74	0.9	35.8	2.53	0.61	0.76	0.93	33.9	2.84	0.62	0.78	0.96	31.7	3.2	0.63	0.81	1
	1440	38.7	2.27	0.63	0.8	0.98	36.9	2.54	0.63	0.82	1	34.9	2.86	0.66	0.85	1	32.7	3.22	0.67	0.89	1
71°F	960	37.8	2.26	0.43	0.55	0.66	36	2.53	0.43	0.56	0.68	34.1	2.84	0.44	0.57	0.7	32.1	3.21	0.44	0.58	0.72
	1200	39.5	2.29	0.44	0.58	0.72	37.7	2.56	0.45	0.59	0.74	35.6	2.87	0.45	0.61	0.76	33.5	3.23	0.46	0.63	0.79
	1440	40.9	2.3	0.46	0.62	0.77	38.8	2.57	0.46	0.63	0.8	36.7	2.89	0.47	0.65	0.83	34.3	3.24	0.48	0.67	0.86

3 TON HIGH EFFICIENCY LGH036H4 (1ST STAGE)

Entering Wet Bulb Temperature	Total Air Volume	Outdoor Air Temperature Entering Outdoor Coil																							
		65°F						75°F						85°F						95°F					
		Total Cool Cap.	Comp. Motor Input	Sensible To Total Ratio (S/T)			Total Cool Cap.	Comp. Motor Input	Sensible To Total Ratio (S/T)			Total Cool Cap.	Comp. Motor Input	Sensible To Total Ratio (S/T)			Total Cool Cap.	Comp. Motor Input	Sensible To Total Ratio (S/T)						
				Dry Bulb					Dry Bulb					Dry Bulb					Dry Bulb						
cfm	kBtuh	kW	75°F	80°F	85°F	kBtuh	kW	75°F	80°F	85°F	kBtuh	kW	75°F	80°F	85°F	kBtuh	kW	75°F	80°F	85°F					
63°F	640	25.5	1.06	0.69	0.81	0.95	24.6	1.22	0.69	0.83	0.97	23.7	1.41	0.7	0.85	0.99	22.5	1.63	0.72	0.87	1				
	800	27	1.05	0.73	0.88	1	26	1.21	0.74	0.91	1	24.9	1.4	0.76	0.93	1	23.7	1.61	0.78	0.96	1				
	960	28.2	1.03	0.78	0.96	1	27.1	1.2	0.79	0.98	1	26	1.39	0.81	1	1	24.8	1.6	0.84	1	1				
67°F	640	27.1	1.05	0.55	0.66	0.77	26.1	1.21	0.55	0.67	0.79	25.1	1.4	0.55	0.68	0.81	23.9	1.61	0.57	0.7	0.83				
	800	28.6	1.03	0.57	0.71	0.85	27.6	1.2	0.58	0.72	0.87	26.4	1.38	0.59	0.73	0.89	25.1	1.6	0.6	0.75	0.92				
	960	29.7	1.02	0.6	0.75	0.92	28.6	1.19	0.61	0.77	0.94	27.3	1.37	0.61	0.78	0.97	25.9	1.59	0.64	0.81	1				
71°F	640	28.6	1.03	0.42	0.53	0.64	27.6	1.2	0.42	0.54	0.65	26.4	1.38	0.43	0.54	0.65	25.2	1.6	0.43	0.55	0.67				
	800	30.2	1.01	0.43	0.56	0.68	29.1	1.18	0.43	0.56	0.69	27.8	1.37	0.44	0.58	0.71	26.5	1.58	0.44	0.59	0.73				
	960	31.4	1	0.45	0.59	0.73	30.3	1.17	0.44	0.6	0.74	28.9	1.35	0.45	0.61	0.76	27.4	1.57	0.45	0.62	0.79				

COOLING RATINGS

NOTE - For Temperatures and Capacities not shown in tables, see bulletin - Cooling Unit Rating Table Correction Factor Data in Miscellaneous Product Data section.

3 TON HIGH EFFICIENCY LGH036H4 (2ND STAGE)

Entering Wet Bulb Temperature	Total Air Volume	Outdoor Air Temperature Entering Outdoor Coil																			
		85°F					95°F					105°F					115°F				
		Total Cool Cap.	Comp. Motor Input	Sensible To Total Ratio (S/T)			Total Cool Cap.	Comp. Motor Input	Sensible To Total Ratio (S/T)			Total Cool Cap.	Comp. Motor Input	Sensible To Total Ratio (S/T)			Total Cool Cap.	Comp. Motor Input	Sensible To Total Ratio (S/T)		
				Dry Bulb					Dry Bulb					Dry Bulb					Dry Bulb		
cfm	kBtuh	kW	75°F	80°F	85°F	kBtuh	kW	75°F	80°F	85°F	kBtuh	kW	75°F	80°F	85°F	kBtuh	kW	75°F	80°F	85°F	
63°F	960	34	2.15	0.71	0.85	0.99	32.4	2.41	0.72	0.87	1	30.8	2.72	0.74	0.9	1	29	3.08	0.76	0.93	1
	1200	35.7	2.17	0.77	0.93	1	34.1	2.44	0.78	0.96	1	32.3	2.74	0.81	0.99	1	30.4	3.1	0.83	1	1
	1440	37	2.19	0.82	1	1	35.4	2.45	0.84	1	1	33.8	2.76	0.87	1	1	32	3.12	0.9	1	1
67°F	960	35.9	2.17	0.57	0.69	0.82	34.3	2.44	0.57	0.7	0.84	32.5	2.74	0.58	0.72	0.86	30.6	3.1	0.6	0.74	0.9
	1200	37.6	2.19	0.6	0.74	0.9	35.8	2.46	0.61	0.76	0.92	34	2.76	0.62	0.78	0.96	31.8	3.11	0.63	0.81	0.99
71°F	1440	38.8	2.21	0.63	0.8	0.97	36.9	2.47	0.64	0.82	1	34.9	2.77	0.66	0.84	1	32.7	3.13	0.67	0.88	1
	960	37.7	2.19	0.43	0.55	0.67	36	2.46	0.43	0.56	0.68	34.2	2.76	0.44	0.57	0.7	32.2	3.12	0.44	0.58	0.72
	1200	39.6	2.22	0.44	0.58	0.72	37.7	2.48	0.44	0.59	0.74	35.7	2.79	0.46	0.61	0.76	33.6	3.14	0.46	0.62	0.79
	1440	40.9	2.23	0.46	0.62	0.78	38.9	2.49	0.46	0.63	0.8	36.8	2.8	0.47	0.65	0.82	34.5	3.15	0.48	0.67	0.85

4 TON STANDARD EFFICIENCY LGH048S4 (1ST STAGE)

Entering Wet Bulb Temperature	Total Air Volume	Outdoor Air Temperature Entering Outdoor Coil																			
		65°F					75°F					85°F					95°F				
		Total Cool Cap.	Comp. Motor Input	Sensible To Total Ratio (S/T)			Total Cool Cap.	Comp. Motor Input	Sensible To Total Ratio (S/T)			Total Cool Cap.	Comp. Motor Input	Sensible To Total Ratio (S/T)			Total Cool Cap.	Comp. Motor Input	Sensible To Total Ratio (S/T)		
				Dry Bulb					Dry Bulb					Dry Bulb					Dry Bulb		
cfm	kBtuh	kW	75°F	80°F	85°F	kBtuh	kW	75°F	80°F	85°F	kBtuh	kW	75°F	80°F	85°F	kBtuh	kW	75°F	80°F	85°F	
63°F	850	37.2	1.49	0.65	0.78	0.92	36.1	1.72	0.66	0.8	0.95	34.6	1.98	0.68	0.82	0.97	32.9	2.27	0.69	0.84	1
	1065	39.4	1.47	0.7	0.86	1	38	1.7	0.71	0.88	1	36.4	1.96	0.72	0.91	1	34.6	2.26	0.74	0.93	1
	1280	41	1.46	0.74	0.94	1	39.5	1.69	0.76	0.97	1	37.8	1.95	0.78	0.99	1	36.2	2.24	0.81	1	1
67°F	850	39.7	1.47	0.52	0.63	0.74	38.2	1.7	0.53	0.64	0.75	36.7	1.96	0.54	0.64	0.77	35	2.25	0.55	0.67	0.8
	1065	41.9	1.45	0.55	0.67	0.82	40.3	1.68	0.55	0.69	0.84	38.7	1.94	0.56	0.7	0.87	36.7	2.24	0.57	0.71	0.89
71°F	1280	43.5	1.44	0.57	0.72	0.9	41.9	1.67	0.57	0.74	0.92	39.9	1.93	0.58	0.75	0.95	38	2.23	0.6	0.78	0.99
	850	42.1	1.45	0.4	0.5	0.61	40.6	1.68	0.41	0.51	0.61	38.9	1.94	0.41	0.51	0.62	37.1	2.23	0.42	0.53	0.64
	1065	44.4	1.43	0.41	0.54	0.65	42.7	1.66	0.42	0.55	0.66	40.9	1.92	0.42	0.55	0.66	38.8	2.22	0.42	0.56	0.69
	1280	46	1.42	0.43	0.56	0.7	44.1	1.65	0.42	0.56	0.71	42.1	1.91	0.44	0.58	0.73	40	2.2	0.42	0.59	0.76

4 TON STANDARD EFFICIENCY LGH048S4 (2ND STAGE)

Entering Wet Bulb Temperature	Total Air Volume	Outdoor Air Temperature Entering Outdoor Coil																			
		85°F					95°F					105°F					115°F				
		Total Cool Cap.	Comp. Motor Input	Sensible To Total Ratio (S/T)			Total Cool Cap.	Comp. Motor Input	Sensible To Total Ratio (S/T)			Total Cool Cap.	Comp. Motor Input	Sensible To Total Ratio (S/T)			Total Cool Cap.	Comp. Motor Input	Sensible To Total Ratio (S/T)		
				Dry Bulb					Dry Bulb					Dry Bulb					Dry Bulb		
cfm	kBtuh	kW	75°F	80°F	85°F	kBtuh	kW	75°F	80°F	85°F	kBtuh	kW	75°F	80°F	85°F	kBtuh	kW	75°F	80°F	85°F	
63°F	1280	47.8	2.83	0.7	0.85	1	45.4	3.15	0.72	0.87	1	43	3.51	0.73	0.91	1	40.3	3.93	0.75	0.94	1
	1600	50	2.86	0.76	0.94	1	47.5	3.17	0.78	0.97	1	44.9	3.54	0.8	1	1	42.5	3.97	0.83	1	1
	1920	51.8	2.88	0.82	1	1	49.7	3.2	0.85	1	1	47.2	3.57	0.87	1	1	44.4	4	0.91	1	1
67°F	1280	50.6	2.87	0.55	0.68	0.81	48.2	3.18	0.57	0.7	0.83	45.5	3.55	0.57	0.71	0.87	42.7	3.97	0.59	0.73	0.9
	1600	52.9	2.9	0.59	0.73	0.9	50.1	3.21	0.6	0.75	0.93	47.3	3.57	0.6	0.77	0.97	44.2	4	0.62	0.81	1
71°F	1920	54.5	2.91	0.6	0.79	0.99	51.6	3.23	0.63	0.82	1	48.7	3.59	0.65	0.85	1	45.4	4.02	0.67	0.89	1
	1280	53.4	2.9	0.42	0.53	0.65	50.9	3.22	0.42	0.56	0.67	48	3.58	0.43	0.56	0.69	45.1	4.01	0.44	0.58	0.71
	1600	55.8	2.93	0.43	0.58	0.71	52.8	3.24	0.44	0.58	0.73	49.9	3.61	0.44	0.6	0.75	46.7	4.04	0.45	0.62	0.79
	1920	57.3	2.95	0.44	0.6	0.77	54.3	3.26	0.46	0.62	0.8	51.3	3.63	0.45	0.64	0.83	47.8	4.05	0.47	0.66	0.87

4 TON HIGH EFFICIENCY LGH048H4 (1ST STAGE)

Entering Wet Bulb Temperature	Total Air Volume	Outdoor Air Temperature Entering Outdoor Coil																			
		65°F					75°F					85°F					95°F				
		Total Cool Cap.	Comp. Motor Input	Sensible To Total Ratio (S/T)			Total Cool Cap.	Comp. Motor Input	Sensible To Total Ratio (S/T)			Total Cool Cap.	Comp. Motor Input	Sensible To Total Ratio (S/T)			Total Cool Cap.	Comp. Motor Input	Sensible To Total Ratio (S/T)		
				Dry Bulb					Dry Bulb					Dry Bulb					Dry Bulb		
cfm	kBtuh	kW	75°F	80°F	85°F	kBtuh	kW	75°F	80°F	85°F	kBtuh	kW	75°F	80°F	85°F	kBtuh	kW	75°F	80°F	85°F	
63°F	850	37.1	1.54	0.67	0.79	0.93	35.9	1.78	0.67	0.81	0.95	34.4	2.05	0.69	0.83	0.97	32.7	2.35	0.7	0.85	1
	1065	39.2	1.53	0.71	0.87	1	37.8	1.77	0.72	0.89	1	36.2	2.03	0.74	0.91	1	34.4	2.34	0.75	0.94	1
	1280	40.9	1.52	0.76	0.94	1	39.4	1.76	0.77	0.97	1	37.6	2.02	0.79	0.99	1	36	2.32	0.82	1	1
67°F	850	39.5	1.53	0.53	0.64	0.75	38.1	1.76	0.54	0.65	0.77	36.6	2.03	0.55	0.66	0.79	34.8	2.34	0.56	0.68	0.81
	1065	41.7	1.51	0.56	0.69	0.83	40.1	1.75	0.57	0.7	0.85	38.4	2.02	0.57	0.72	0.88	36.5	2.32	0.58	0.73	0.9
71°F	1280	43.2	1.5	0.58	0.73	0.9	41.7	1.74	0.58	0.75	0.93	39.7	2	0.59	0.77	0.96	37.7	2.31	0.62	0.79	0.99
	850	41.9	1.51	0.41	0.51	0.62	40.4	1.75	0.41	0.52	0.62	38.7	2.01	0.42	0.53	0.63	36.9	2.32	0.43	0.54	0.65
	1065	44.2	1.49	0.42	0.55	0.67	42.5	1.73	0.42	0.56	0.68	40.6	1.99	0.43	0.56	0.69	38.5	2.3	0.43	0.57	0.7
	1280	45.8	1.48	0.43	0.57	0.71	43.9	1.71	0.42	0.58	0.72	41.9	1.98	0.45	0.58	0.74	39.8	2.28	0.43	0.6	0.77

COOLING RATINGS

NOTE - For Temperatures and Capacities not shown in tables, see bulletin - Cooling Unit Rating Table Correction Factor Data in Miscellaneous Product Data section.

4 TON HIGH EFFICIENCY LGH048H4 (2ND STAGE)

Entering Wet Bulb Temperature	Total Air Volume	Outdoor Air Temperature Entering Outdoor Coil																							
		85°F						95°F						105°F						115°F					
		Total Cool Cap.	Comp. Motor Input	Sensible To Total Ratio (S/T)			Total Cool Cap.	Comp. Motor Input	Sensible To Total Ratio (S/T)			Total Cool Cap.	Comp. Motor Input	Sensible To Total Ratio (S/T)			Total Cool Cap.	Comp. Motor Input	Sensible To Total Ratio (S/T)						
				Dry Bulb					Dry Bulb					Dry Bulb					Dry Bulb						
cfm	kBtuh	kW	75°F	80°F	85°F	kBtuh	kW	75°F	80°F	85°F	kBtuh	kW	75°F	80°F	85°F	kBtuh	kW	75°F	80°F	85°F					
63°F	1280	47.6	2.92	0.7	0.84	0.99	45.2	3.24	0.71	0.87	1	43	3.62	0.73	0.9	1	40.3	4.06	0.75	0.94	1				
	1600	49.9	2.95	0.76	0.94	1	47.4	3.27	0.77	0.96	1	44.9	3.64	0.8	0.99	1	42.3	4.09	0.83	1	1				
	1920	51.6	2.97	0.82	1	1	49.6	3.29	0.84	1	1	47.1	3.68	0.87	1	1	44.4	4.12	0.9	1	1				
67°F	1280	50.4	2.95	0.55	0.67	0.81	48	3.28	0.57	0.7	0.83	45.5	3.66	0.57	0.71	0.86	42.7	4.1	0.59	0.73	0.9				
	1600	52.7	2.98	0.59	0.73	0.9	50.1	3.3	0.6	0.75	0.92	47.3	3.68	0.6	0.77	0.96	44.3	4.12	0.62	0.8	1				
	1920	54.3	3	0.62	0.79	0.98	51.6	3.32	0.62	0.81	1	48.7	3.7	0.65	0.85	1	45.5	4.14	0.67	0.88	1				
71°F	1280	53.2	2.98	0.43	0.54	0.65	50.7	3.31	0.42	0.55	0.66	48	3.69	0.43	0.56	0.69	45.1	4.14	0.44	0.58	0.71				
	1600	55.6	3.01	0.44	0.58	0.71	52.8	3.33	0.44	0.59	0.73	49.9	3.71	0.44	0.6	0.75	46.8	4.16	0.45	0.62	0.78				
	1920	57.2	3.03	0.44	0.6	0.77	54.2	3.35	0.46	0.62	0.8	51.2	3.73	0.46	0.64	0.82	47.9	4.17	0.47	0.66	0.86				

5 TON STANDARD EFFICIENCY LGH060S4 (1ST STAGE)

Entering Wet Bulb Temperature	Total Air Volume	Outdoor Air Temperature Entering Outdoor Coil																							
		65°F						75°F						85°F						95°F					
		Total Cool Cap.	Comp. Motor Input	Sensible To Total Ratio (S/T)			Total Cool Cap.	Comp. Motor Input	Sensible To Total Ratio (S/T)			Total Cool Cap.	Comp. Motor Input	Sensible To Total Ratio (S/T)			Total Cool Cap.	Comp. Motor Input	Sensible To Total Ratio (S/T)						
				Dry Bulb					Dry Bulb					Dry Bulb					Dry Bulb						
cfm	kBtuh	kW	75°F	80°F	85°F	kBtuh	kW	75°F	80°F	85°F	kBtuh	kW	75°F	80°F	85°F	kBtuh	kW	75°F	80°F	85°F					
63°F	1070	48	1.76	0.66	0.78	0.92	46.1	2.08	0.66	0.8	0.94	44.1	2.42	0.68	0.81	0.96	42.1	2.79	0.69	0.84	0.99				
	1335	50.8	1.75	0.7	0.85	1	48.8	2.07	0.71	0.88	1	46.7	2.41	0.73	0.9	1	44.4	2.78	0.74	0.93	1				
	1600	53	1.74	0.75	0.93	1	50.8	2.06	0.76	0.95	1	48.6	2.4	0.78	0.97	1	46.1	2.77	0.8	1	1				
67°F	1070	51.2	1.75	0.53	0.64	0.74	49	2.06	0.53	0.64	0.76	46.9	2.41	0.53	0.65	0.78	45.1	2.78	0.54	0.67	0.79				
	1335	54.1	1.73	0.55	0.67	0.81	52	2.06	0.56	0.69	0.83	49.7	2.4	0.57	0.7	0.86	47.4	2.78	0.58	0.72	0.88				
	1600	56.4	1.72	0.58	0.72	0.89	54	2.05	0.58	0.73	0.91	51.6	2.39	0.57	0.75	0.93	49	2.77	0.6	0.78	0.97				
71°F	1070	54.4	1.73	0.41	0.51	0.61	52.3	2.05	0.41	0.51	0.62	50	2.4	0.4	0.51	0.62	47.7	2.77	0.41	0.52	0.64				
	1335	57.5	1.72	0.41	0.54	0.65	55.2	2.05	0.42	0.55	0.67	52.7	2.39	0.42	0.55	0.68	50.2	2.77	0.43	0.56	0.69				
	1600	59.8	1.71	0.43	0.56	0.69	57.4	2.04	0.43	0.57	0.71	54.6	2.39	0.42	0.57	0.72	51.9	2.76	0.44	0.59	0.75				

5 TON STANDARD EFFICIENCY LGH060S4 (2ND STAGE)

Entering Wet Bulb Temperature	Total Air Volume	Outdoor Air Temperature Entering Outdoor Coil																							
		85°F						95°F						105°F						115°F					
		Total Cool Cap.	Comp. Motor Input	Sensible To Total Ratio (S/T)			Total Cool Cap.	Comp. Motor Input	Sensible To Total Ratio (S/T)			Total Cool Cap.	Comp. Motor Input	Sensible To Total Ratio (S/T)			Total Cool Cap.	Comp. Motor Input	Sensible To Total Ratio (S/T)						
				Dry Bulb					Dry Bulb					Dry Bulb					Dry Bulb						
cfm	kBtuh	kW	75°F	80°F	85°F	kBtuh	kW	75°F	80°F	85°F	kBtuh	kW	75°F	80°F	85°F	kBtuh	kW	75°F	80°F	85°F					
63°F	1600	59.5	3.42	0.69	0.84	0.98	56.9	3.84	0.71	0.86	1	54.1	4.33	0.73	0.89	1	51	4.89	0.75	0.92	1				
	2000	62.6	3.46	0.75	0.93	1	59.7	3.87	0.77	0.95	1	56.6	4.36	0.78	0.98	1	53.3	4.92	0.82	1	1				
	2400	64.9	3.48	0.8	0.99	1	62.1	3.9	0.83	1	1	59.5	4.39	0.85	1	1	56.4	4.97	0.89	1	1				
67°F	1600	62.9	3.46	0.55	0.67	0.8	60.3	3.88	0.56	0.69	0.82	57.4	4.37	0.57	0.7	0.85	54	4.93	0.58	0.72	0.88				
	2000	66.3	3.5	0.59	0.73	0.88	63.3	3.92	0.6	0.74	0.91	60	4.4	0.6	0.76	0.94	56.6	4.97	0.62	0.79	0.98				
	2400	68.4	3.52	0.61	0.77	0.96	65.3	3.94	0.63	0.8	0.99	61.8	4.42	0.64	0.82	1	58.1	4.98	0.65	0.86	1				
71°F	1600	66.9	3.5	0.42	0.53	0.65	63.9	3.92	0.43	0.54	0.66	60.8	4.41	0.43	0.56	0.68	57.4	4.98	0.43	0.57	0.7				
	2000	70	3.54	0.44	0.57	0.7	66.8	3.96	0.44	0.58	0.72	63.4	4.44	0.44	0.59	0.73	59.7	5.01	0.45	0.6	0.76				
	2400	72.2	3.57	0.44	0.6	0.75	69	3.99	0.44	0.61	0.78	65.2	4.47	0.47	0.63	0.8	61.5	5.03	0.46	0.64	0.83				

5 TON HIGH EFFICIENCY LGH060H4 (1ST STAGE)

Entering Wet Bulb Temperature	Total Air Volume	Outdoor Air Temperature Entering Outdoor Coil																							
		65°F						75°F						85°F						95°F					
		Total Cool Cap.	Comp. Motor Input	Sensible To Total Ratio (S/T)			Total Cool Cap.	Comp. Motor Input	Sensible To Total Ratio (S/T)			Total Cool Cap.	Comp. Motor Input	Sensible To Total Ratio (S/T)			Total Cool Cap.	Comp. Motor Input	Sensible To Total Ratio (S/T)						
				Dry Bulb					Dry Bulb					Dry Bulb					Dry Bulb						
cfm	kBtuh	kW	75°F	80°F	85°F	kBtuh	kW	75°F	80°F	85°F	kBtuh	kW	75°F	80°F	85°F	kBtuh	kW	75°F	80°F	85°F					
63°F	1070	47.4	1.82	0.66	0.79	0.92	45.5	2.14	0.67	0.8	0.94	43.5	2.49	0.68	0.82	0.97	41.5	2.87	0.7	0.85	0.99				
	1335	50.1	1.81	0.71	0.85	1	48.2	2.13	0.72	0.88	1	46	2.48	0.73	0.91	1	43.7	2.86	0.75	0.93	1				
	1600	52.3	1.8	0.75	0.93	1	50	2.13	0.77	0.95	1	47.9	2.48	0.79	0.98	1	45.5	2.86	0.8	1	1				
67°F	1070	50.4	1.81	0.53	0.64	0.75	48.5	2.13	0.53	0.65	0.76	46.2	2.48	0.53	0.65	0.78	44.2	2.86	0.55	0.67	0.8				
	1335	53.3	1.8	0.55	0.68	0.82	51.2	2.13	0.57	0.69	0.84	49	2.48	0.57	0.71	0.86	46.7	2.86	0.58	0.72	0.89				
	1600	55.6	1.79	0.58	0.72	0.89	53.2	2.12	0.59	0.73	0.91	50.8	2.48	0.57	0.76	0.94	48.2	2.86	0.61	0.78	0.97				
71°F	1070	53.6	1.8	0.41	0.51	0.62	51.5	2.12	0.41	0.52	0.62	49.3	2.47	0.41	0.52	0.63	47	2.86	0.42	0.53	0.65				
	1335	56.7	1.79	0.42	0.54	0.66	54.4	2.12	0.43	0.55	0.67	51.9	2.47	0.43	0.56	0.68	49.5	2.86	0.43	0.57	0.7				
	1600	58.9	1.78	0.43	0.57	0.7	56.5	2.12	0.44	0.58	0.71	53.9	2.47	0.44	0.58	0.72	51.2	2.86	0.45	0.6	0.75				

COOLING RATINGS

NOTE - For Temperatures and Capacities not shown in tables, see bulletin - Cooling Unit Rating Table Correction Factor Data in Miscellaneous Product Data section.

5 TON HIGH EFFICIENCY LGH060H4 (2ND STAGE)

Entering Wet Bulb Temperature	Total Air Volume	Outdoor Air Temperature Entering Outdoor Coil																			
		85°F					95°F					105°F					115°F				
		Total Cool Cap.	Comp. Motor Input	Sensible To Total Ratio (S/T)			Total Cool Cap.	Comp. Motor Input	Sensible To Total Ratio (S/T)			Total Cool Cap.	Comp. Motor Input	Sensible To Total Ratio (S/T)			Total Cool Cap.	Comp. Motor Input	Sensible To Total Ratio (S/T)		
				Dry Bulb					Dry Bulb					Dry Bulb					Dry Bulb		
cfm	kBtuh	kW	75°F	80°F	85°F	kBtuh	kW	75°F	80°F	85°F	kBtuh	kW	75°F	80°F	85°F	kBtuh	kW	75°F	80°F	85°F	
63°F	1600	59.5	3.5	0.69	0.84	0.99	56.9	3.93	0.71	0.86	1	54	4.42	0.73	0.89	1	50.9	4.99	0.75	0.93	1
	2000	62.6	3.54	0.75	0.93	1	59.7	3.96	0.77	0.95	1	56.5	4.45	0.79	0.98	1	53.3	5.02	0.82	1	1
	2400	64.9	3.56	0.8	1	1	62.2	3.99	0.83	1	1	59.4	4.49	0.85	1	1	56.3	5.07	0.9	1	1
67°F	1600	63	3.54	0.54	0.67	0.8	60.2	3.97	0.56	0.68	0.82	57.3	4.46	0.57	0.7	0.85	53.9	5.03	0.58	0.72	0.88
	2000	66.4	3.58	0.59	0.73	0.89	63.2	4.01	0.59	0.74	0.92	59.7	4.5	0.6	0.76	0.94	56.4	5.07	0.62	0.79	0.98
71°F	1600	66.8	3.59	0.42	0.53	0.64	63.9	4.01	0.42	0.54	0.66	60.8	4.51	0.43	0.56	0.68	57.3	5.08	0.44	0.57	0.7
	2000	70.1	3.63	0.43	0.57	0.7	66.8	4.05	0.44	0.58	0.72	63.2	4.54	0.44	0.58	0.74	59.6	5.12	0.44	0.6	0.76
	2400	72.3	3.65	0.45	0.6	0.76	68.8	4.08	0.45	0.61	0.77	65.2	4.57	0.46	0.63	0.8	61.4	5.14	0.46	0.65	0.84

6 TON HIGH EFFICIENCY LGH072H4

Entering Wet Bulb Temperature	Total Air Volume	Outdoor Air Temperature Entering Outdoor Coil																			
		85°F					95°F					105°F					115°F				
		Total Cool Cap.	Comp. Motor Input	Sensible To Total Ratio (S/T)			Total Cool Cap.	Comp. Motor Input	Sensible To Total Ratio (S/T)			Total Cool Cap.	Comp. Motor Input	Sensible To Total Ratio (S/T)			Total Cool Cap.	Comp. Motor Input	Sensible To Total Ratio (S/T)		
				Dry Bulb					Dry Bulb					Dry Bulb					Dry Bulb		
cfm	kBtuh	kW	75°F	80°F	85°F	kBtuh	kW	75°F	80°F	85°F	kBtuh	kW	75°F	80°F	85°F	kBtuh	kW	75°F	80°F	85°F	
63°F	1920	72.3	4.53	0.71	0.85	0.99	69.1	5.05	0.73	0.87	1	65.7	5.63	0.74	0.9	1	61.8	6.28	0.76	0.93	1
	2400	76.2	4.55	0.76	0.93	1	72.8	5.06	0.78	0.96	1	69	5.63	0.8	0.98	1	64.9	6.28	0.82	1	1
	2880	79	4.56	0.82	1	1	75.6	5.06	0.84	1	1	72.5	5.64	0.86	1	1	68.8	6.31	0.9	1	1
67°F	1920	76.7	4.55	0.56	0.68	0.81	73.3	5.05	0.57	0.69	0.83	69.9	5.64	0.58	0.72	0.86	66	6.29	0.59	0.73	0.89
	2400	80.8	4.56	0.59	0.74	0.89	77.2	5.07	0.6	0.75	0.92	73.2	5.65	0.62	0.77	0.95	68.9	6.3	0.63	0.8	0.98
	2880	83.6	4.57	0.63	0.79	0.97	79.7	5.07	0.63	0.81	0.99	75.8	5.65	0.65	0.84	1	71	6.3	0.66	0.87	1
71°F	1920	81.6	4.56	0.43	0.55	0.66	78.1	5.07	0.43	0.55	0.67	74.4	5.65	0.43	0.56	0.69	70.1	6.3	0.44	0.58	0.71
	2400	85.7	4.58	0.44	0.58	0.71	81.8	5.08	0.45	0.59	0.73	77.7	5.66	0.45	0.6	0.75	73.1	6.31	0.46	0.62	0.77
	2880	88.4	4.59	0.46	0.61	0.77	84.4	5.09	0.46	0.62	0.79	80	5.67	0.46	0.63	0.8	75.5	6.32	0.47	0.65	0.84

6 TON HIGH EFFICIENCY LGH074H4 (1ST STAGE)

Entering Wet Bulb Temperature	Total Air Volume	Outdoor Air Temperature Entering Outdoor Coil																			
		65°F					75°F					85°F					95°F				
		Total Cool Cap.	Comp. Motor Input	Sensible To Total Ratio (S/T)			Total Cool Cap.	Comp. Motor Input	Sensible To Total Ratio (S/T)			Total Cool Cap.	Comp. Motor Input	Sensible To Total Ratio (S/T)			Total Cool Cap.	Comp. Motor Input	Sensible To Total Ratio (S/T)		
				Dry Bulb					Dry Bulb					Dry Bulb					Dry Bulb		
cfm	kBtuh	kW	75°F	80°F	85°F	kBtuh	kW	75°F	80°F	85°F	kBtuh	kW	75°F	80°F	85°F	kBtuh	kW	75°F	80°F	85°F	
63°F	1200	53.3	2.27	0.68	0.81	0.92	51	2.59	0.69	0.82	0.94	48.3	2.95	0.7	0.83	0.96	45.6	3.36	0.71	0.85	0.98
	1600	57.8	2.26	0.74	0.88	1	55.2	2.58	0.75	0.9	1	52.5	2.94	0.77	0.92	1	49.3	3.36	0.78	0.95	1
	2000	61.2	2.25	0.8	0.96	1	58.2	2.57	0.81	0.98	1	55.3	2.94	0.83	1	1	52.5	3.35	0.84	1	1
67°F	1200	57.2	2.26	0.55	0.66	0.77	54.7	2.58	0.55	0.67	0.78	51.9	2.94	0.55	0.67	0.79	48.9	3.36	0.55	0.68	0.81
	1600	61.9	2.25	0.58	0.72	0.85	59.2	2.57	0.59	0.73	0.86	56.3	2.93	0.59	0.74	0.88	53	3.35	0.6	0.76	0.91
	2000	65.4	2.24	0.62	0.78	0.93	62.3	2.56	0.62	0.78	0.94	59.2	2.93	0.63	0.8	0.97	55.6	3.34	0.64	0.82	0.99
71°F	1200	61.2	2.25	0.43	0.53	0.63	58.6	2.57	0.42	0.53	0.64	55.8	2.93	0.42	0.53	0.64	52.6	3.35	0.41	0.53	0.65
	1600	66.3	2.23	0.44	0.57	0.69	63.3	2.56	0.44	0.57	0.7	60.2	2.92	0.44	0.58	0.71	56.7	3.34	0.44	0.59	0.73
	2000	69.6	2.22	0.45	0.61	0.75	66.5	2.54	0.46	0.61	0.76	63.1	2.91	0.45	0.62	0.77	59.6	3.33	0.46	0.63	0.8

6 TON HIGH EFFICIENCY LGH074H4 (2ND STAGE)

Entering Wet Bulb Temperature	Total Air Volume	Outdoor Air Temperature Entering Outdoor Coil																			
		85°F					95°F					105°F					115°F				
		Total Cool Cap.	Comp. Motor Input	Sensible To Total Ratio (S/T)			Total Cool Cap.	Comp. Motor Input	Sensible To Total Ratio (S/T)			Total Cool Cap.	Comp. Motor Input	Sensible To Total Ratio (S/T)			Total Cool Cap.	Comp. Motor Input	Sensible To Total Ratio (S/T)		
				Dry Bulb					Dry Bulb					Dry Bulb					Dry Bulb		
cfm	kBtuh	kW	75°F	80°F	85°F	kBtuh	kW	75°F	80°F	85°F	kBtuh	kW	75°F	80°F	85°F	kBtuh	kW	75°F	80°F	85°F	
63°F	1920	68.6	4.12	0.73	0.88	1	64.9	4.65	0.75	0.9	1	60.9	5.25	0.77	0.93	1	56.6	5.94	0.79	0.96	1
	2400	72.2	4.16	0.79	0.96	1	68.1	4.68	0.81	0.99	1	63.9	5.28	0.83	1	1	60	5.97	0.86	1	1
	2880	75.2	4.18	0.85	1	1	71.6	4.72	0.87	1	1	67.6	5.32	0.9	1	1	63.4	6.01	0.94	1	1
67°F	1920	73	4.16	0.57	0.71	0.85	69	4.69	0.59	0.73	0.87	64.8	5.29	0.59	0.74	0.89	60.4	5.97	0.6	0.77	0.93
	2400	76.7	4.2	0.62	0.77	0.93	72.4	4.73	0.62	0.79	0.95	67.9	5.32	0.63	0.81	0.98	63	6	0.64	0.84	1
	2880	79.1	4.22	0.64	0.83	0.99	74.8	4.75	0.66	0.85	1	69.9	5.34	0.67	0.88	1	65	6.02	0.69	0.91	1
71°F	1920	77.6	4.21	0.44	0.56	0.69	73.5	4.74	0.43	0.57	0.7	69.1	5.34	0.43	0.58	0.72	64.2	6.02	0.43	0.59	0.74
	2400	81.1	4.24	0.45	0.6	0.75	76.8	4.77	0.45	0.61	0.77	72	5.37	0.45	0.62	0.79	67.1	6.05	0.44	0.64	0.81
	2880	83.7	4.27	0.47	0.64	0.8	79.3	4.8	0.46	0.65	0.83	74.2	5.4	0.48	0.66	0.85	69.2	6.07	0.48	0.68	0.89

DEHUMIDIFICATION SYSTEM RATINGS

3 TON STANDARD OR HIGH EFFICIENCY LGH036S4/H4 WITH DEHUMIDIFICATION OPERATING

Entering Wet Bulb Temperature	Total Air Volume	Outdoor Air Temperature Entering Outdoor Coil																			
		65°F					75°F					85°F					95°F				
		Total Cool Cap.	Comp. Motor Input	Sensible To Total Ratio (S/T)			Total Cool Cap.	Comp. Motor Input	Sensible To Total Ratio (S/T)			Total Cool Cap.	Comp. Motor Input	Sensible To Total Ratio (S/T)			Total Cool Cap.	Comp. Motor Input	Sensible To Total Ratio (S/T)		
				Dry Bulb					Dry Bulb					Dry Bulb					Dry Bulb		
cfm	kBtuh	kW	75°F	80°F	85°F	kBtuh	kW	75°F	80°F	85°F	kBtuh	kW	75°F	80°F	85°F	kBtuh	kW	75°F	80°F	85°F	
63°F	640	22.6	1.52	0.49	0.63	0.77	18.9	1.73	0.42	0.59	0.76	15.2	1.94	0.32	0.53	0.75	11.4	2.17	0.14	0.43	0.70
	800	24.3	1.53	0.53	0.70	0.85	20.2	1.73	0.47	0.67	0.84	16.1	1.94	0.37	0.62	0.86	11.8	2.17	0.20	0.54	0.87
	960	25.6	1.54	0.57	0.75	0.94	21.1	1.74	0.51	0.74	0.95	16.5	1.95	0.43	0.72	0.98	11.9	2.17	0.26	0.66	1.00
67°F	640	25.5	1.54	0.36	0.48	0.61	21.8	1.75	0.28	0.43	0.57	18.0	1.96	0.17	0.35	0.52	14.1	2.19	-0.02	0.22	0.44
	800	27.4	1.56	0.38	0.52	0.67	23.3	1.76	0.30	0.47	0.64	19.0	1.97	0.18	0.39	0.60	14.6	2.20	-0.01	0.27	0.54
	960	28.8	1.57	0.40	0.57	0.72	24.3	1.77	0.32	0.51	0.71	19.7	1.98	0.20	0.44	0.68	15.2	2.20	0.01	0.28	0.64
71°F	640	28.2	1.56	0.25	0.37	0.48	24.5	1.77	0.16	0.30	0.43	20.7	1.98	0.05	0.21	0.36	16.8	2.22	-0.13	0.07	0.26
	800	30.4	1.58	0.25	0.39	0.52	26.2	1.78	0.17	0.32	0.47	22.0	1.99	0.05	0.23	0.41	17.4	2.23	-0.14	0.09	0.32
	960	31.9	1.60	0.27	0.41	0.56	27.4	1.79	0.18	0.35	0.52	22.7	2.00	0.04	0.25	0.46	17.9	2.23	-0.17	0.11	0.35

4 TON STANDARD OR HIGH EFFICIENCY LGH048S4/H4 WITH DEHUMIDIFICATION OPERATING

Entering Wet Bulb Temperature	Total Air Volume	Outdoor Air Temperature Entering Outdoor Coil																			
		65°F					75°F					85°F					95°F				
		Total Cool Cap.	Comp. Motor Input	Sensible To Total Ratio (S/T)			Total Cool Cap.	Comp. Motor Input	Sensible To Total Ratio (S/T)			Total Cool Cap.	Comp. Motor Input	Sensible To Total Ratio (S/T)			Total Cool Cap.	Comp. Motor Input	Sensible To Total Ratio (S/T)		
				Dry Bulb					Dry Bulb					Dry Bulb					Dry Bulb		
cfm	kBtuh	kW	75°F	80°F	85°F	kBtuh	kW	75°F	80°F	85°F	kBtuh	kW	75°F	80°F	85°F	kBtuh	kW	75°F	80°F	85°F	
63°F	890	30.4	2.14	0.46	0.61	0.76	25.5	2.37	0.40	0.57	0.75	20.4	2.61	0.30	0.52	0.74	15.1	2.90	0.14	0.43	0.71
	1115	32.4	2.17	0.51	0.68	0.86	26.8	2.40	0.45	0.65	0.87	21.1	2.65	0.36	0.61	0.89	15.2	2.93	0.19	0.55	0.91
	1340	33.7	2.19	0.55	0.76	0.96	27.6	2.42	0.49	0.74	0.99	21.3	2.67	0.41	0.72	1.00	14.8	2.95	0.24	0.69	0.99
67°F	890	34.5	2.17	0.33	0.46	0.59	29.5	2.40	0.26	0.40	0.55	24.4	2.65	0.15	0.32	0.51	19.0	2.93	-0.02	0.21	0.44
	1115	36.6	2.20	0.35	0.50	0.66	30.9	2.43	0.28	0.45	0.62	25.3	2.68	0.16	0.37	0.59	19.1	2.96	-0.03	0.26	0.54
	1340	38.2	2.23	0.38	0.55	0.72	32.7	2.45	0.29	0.47	0.71	25.5	2.70	0.18	0.43	0.69	18.9	2.98	-0.02	0.32	0.65
71°F	890	38.7	2.20	0.23	0.33	0.45	33.6	2.43	0.15	0.27	0.40	28.4	2.68	0.04	0.19	0.34	23.0	2.96	-0.12	0.06	0.24
	1115	41.1	2.23	0.23	0.36	0.49	35.4	2.46	0.14	0.29	0.45	29.4	2.71	0.03	0.21	0.39	23.3	2.99	-0.16	0.08	0.30
	1340	42.7	2.26	0.24	0.38	0.54	36.9	2.48	0.15	0.31	0.50	29.9	2.73	0.02	0.23	0.42	23.4	3.01	-0.19	0.09	0.36

5 TON STANDARD OR HIGH EFFICIENCY LGH060S4/H4 WITH DEHUMIDIFICATION OPERATING

Entering Wet Bulb Temperature	Total Air Volume	Outdoor Air Temperature Entering Outdoor Coil																			
		65°F					75°F					85°F					95°F				
		Total Cool Cap.	Comp. Motor Input	Sensible To Total Ratio (S/T)			Total Cool Cap.	Comp. Motor Input	Sensible To Total Ratio (S/T)			Total Cool Cap.	Comp. Motor Input	Sensible To Total Ratio (S/T)			Total Cool Cap.	Comp. Motor Input	Sensible To Total Ratio (S/T)		
				Dry Bulb					Dry Bulb					Dry Bulb					Dry Bulb		
cfm	kBtuh	kW	75°F	80°F	85°F	kBtuh	kW	75°F	80°F	85°F	kBtuh	kW	75°F	80°F	85°F	kBtuh	kW	75°F	80°F	85°F	
63°F	1080	36.2	2.76	0.43	0.59	0.74	29.8	3.07	0.35	0.53	0.73	23.3	3.41	0.21	0.44	0.69	16.4	3.78	-0.03	0.29	0.63
	1350	39.2	2.79	0.48	0.64	0.85	31.6	3.09	0.40	0.62	0.84	24.2	3.42	0.26	0.55	0.84	16.6	3.78	0.02	0.43	0.84
	1620	40.8	2.81	0.52	0.73	0.94	33.5	3.11	0.46	0.66	0.96	24.7	3.43	0.32	0.66	0.98	16.6	3.79	0.07	0.57	1.00
67°F	1080	41.5	2.81	0.30	0.43	0.57	35.3	3.12	0.21	0.36	0.52	28.3	3.46	0.07	0.26	0.45	21.3	3.84	-0.16	0.10	0.34
	1350	44.5	2.84	0.33	0.48	0.63	37.1	3.15	0.23	0.41	0.60	29.7	3.48	0.08	0.31	0.53	22.0	3.85	-0.16	0.14	0.44
	1620	46.8	2.87	0.35	0.52	0.69	38.9	3.17	0.26	0.45	0.67	31.5	3.50	0.05	0.29	0.63	22.1	3.86	-0.16	0.20	0.56
71°F	1080	47.2	2.86	0.20	0.31	0.43	40.5	3.18	0.10	0.23	0.37	33.6	3.52	-0.03	0.13	0.28	26.5	3.90	-0.24	-0.04	0.16
	1350	50.4	2.90	0.20	0.33	0.47	43.0	3.21	0.10	0.26	0.42	35.4	3.55	-0.04	0.15	0.34	27.5	3.92	-0.28	-0.03	0.21
	1620	52.9	2.93	0.21	0.36	0.51	44.6	3.23	0.10	0.28	0.46	36.4	3.56	-0.05	0.16	0.39	28.4	3.93	-0.30	-0.05	0.27

6 TON HIGH EFFICIENCY LGH072H4 WITH DEHUMIDIFICATION OPERATING

Entering Wet Bulb Temperature	Total Air Volume	Outdoor Air Temperature Entering Outdoor Coil																			
		65°F					75°F					85°F					95°F				
		Total Cool Cap.	Comp. Motor Input	Sensible To Total Ratio (S/T)			Total Cool Cap.	Comp. Motor Input	Sensible To Total Ratio (S/T)			Total Cool Cap.	Comp. Motor Input	Sensible To Total Ratio (S/T)			Total Cool Cap.	Comp. Motor Input	Sensible To Total Ratio (S/T)		
				Dry Bulb					Dry Bulb					Dry Bulb					Dry Bulb		
cfm	kBtuh	kW	75°F	80°F	85°F	kBtuh	kW	75°F	80°F	85°F	kBtuh	kW	75°F	80°F	85°F	kBtuh	kW	75°F	80°F	85°F	
63°F	1920	44.2	3.30	0.56	0.76	0.94	35.7	3.66	0.48	0.74	0.97	28.1	4.06	0.30	0.65	0.99	19.5	4.50	0.11	0.55	1.00
	2400	46.0	3.34	0.62	0.86	1.00	36.9	3.69	0.56	0.85	0.99	27.5	4.07	0.45	0.86	1.00	18.0	4.49	0.23	0.86	1.00
	2880	47.2	3.36	0.69	0.95	1.00	37.3	3.70	0.65	0.99	1.00	27.7	4.07	0.57	1.00	0.99	19.3	4.51	0.38	0.82	1.00
67°F	1920	50.1	3.38	0.36	0.55	0.73	41.7	3.75	0.27	0.49	0.71	33.0	4.14	0.09	0.40	0.68	24.1	4.58	-0.21	0.23	0.61
	2400	52.0	3.42	0.40	0.61	0.82	42.9	3.77	0.30	0.57	0.82	33.4	4.16	0.13	0.49	0.81	23.7	4.58	-0.17	0.34	0.80
	2880	53.5	3.45	0.44	0.68	0.91	43.4	3.79	0.34	0.65	0.93	33.4	4.17	0.18	0.58	0.97	22.9	4.58	-0.15	0.47	1.00
71°F	1920	56.0	3.47	0.21	0.38	0.55	47.6	3.83	0.10	0.30	0.49	38.5	4.23	-0.08	0.18	0.42	30.1	4.68	-0.37	-0.04	0.26
	2400	58.1	3.51	0.22	0.42	0.61	48.7	3.86	0.09	0.34	0.57	39.0	4.25	-0.10	0.22	0.50	29.4	4.68	-0.42	0.00	0.40
	2880	59.8	3.54	0.22	0.45	0.67	49.6	3.89	0.10	0.38	0.64	40.2	4.28	-0.10	0.21	0.60	28.9	4.69	-0.48	0.03	0.52

DEHUMIDIFICATION SYSTEM RATINGS

6 TON HIGH EFFICIENCY LGH074H4 WITH DEHUMIDIFICATION OPERATING

Entering Wet Bulb Temperature	Total Air Volume	Outdoor Air Temperature Entering Outdoor Coil																			
		65°F					75°F					85°F					95°F				
		Total Cool Cap.	Comp. Motor Input	Sensible To Total Ratio (S/T) Dry Bulb			Total Cool Cap.	Comp. Motor Input	Sensible To Total Ratio (S/T) Dry Bulb			Total Cool Cap.	Comp. Motor Input	Sensible To Total Ratio (S/T) Dry Bulb			Total Cool Cap.	Comp. Motor Input	Sensible To Total Ratio (S/T) Dry Bulb		
				75°F	80°F	85°F			75°F	80°F	85°F			75°F	80°F	85°F			75°F	80°F	85°F
		cfm	kBtuh	kW	75°F	80°F	85°F	kBtuh	kW	75°F	80°F	85°F	kBtuh	kW	75°F	80°F	85°F	kBtuh	kW	75°F	80°F
63°F	1200	38.4	3.17	0.44	0.59	0.74	31.8	3.50	0.35	0.53	0.71	24.9	3.89	0.21	0.45	0.68	18.0	4.36	-0.04	0.29	0.61
	1600	41.9	3.22	0.49	0.68	0.86	34.4	3.54	0.42	0.63	0.86	26.4	3.91	0.28	0.58	0.86	18.4	4.36	0.03	0.45	0.86
	2000	44.1	3.26	0.55	0.77	0.97	35.5	3.56	0.49	0.76	1.00	28.1	3.94	0.35	0.64	1.00	18.1	4.36	0.10	0.64	1.00
67°F	1200	44.0	3.23	0.30	0.43	0.57	37.3	3.56	0.20	0.36	0.52	30.4	3.96	0.06	0.25	0.45	23.0	4.43	-0.18	0.09	0.33
	1600	47.7	3.29	0.33	0.49	0.65	39.8	3.61	0.23	0.43	0.61	32.0	3.99	0.08	0.32	0.56	23.8	4.44	-0.18	0.15	0.47
	2000	50.3	3.34	0.36	0.55	0.73	41.8	3.64	0.26	0.49	0.70	32.9	4.01	0.07	0.39	0.67	23.9	4.44	-0.18	0.23	0.62
71°F	1200	49.6	3.30	0.19	0.31	0.43	42.8	3.63	0.10	0.23	0.37	35.6	4.04	-0.05	0.12	0.28	28.4	4.51	-0.27	-0.06	0.15
	1600	53.7	3.37	0.19	0.34	0.48	45.9	3.69	0.09	0.26	0.43	37.8	4.07	-0.06	0.15	0.35	29.5	4.53	-0.31	-0.04	0.22
	2000	56.6	3.41	0.20	0.37	0.54	47.7	3.72	0.09	0.30	0.49	38.9	4.10	-0.08	0.17	0.42	29.6	4.53	-0.36	-0.02	0.30

BLOWER DATA - DIRECT DRIVE - O36

BLOWER TABLE INCLUDES RESISTANCE FOR BASE UNIT ONLY WITH DRY INDOOR COIL AND AIR FILTERS IN PLACE.

FOR ALL UNITS ADD:

- 1 - Any factory installed options air resistance (heat section, economizer, etc.).
 - 2 - Any field installed accessories air resistance (duct resistance, diffuser, etc.).
- See page 39 for wet coil and options/accessory air resistance data.

DOWNFLOW

External Static Press. in. w.g.	Percentage of Total Motor Torque																								
	20%		30%		40%		50%		60%		70%		80%		90%		100%								
	Cfm	RPM	Cfm	RPM	Cfm	RPM	Cfm	RPM	Cfm	RPM	Cfm	RPM	Cfm	RPM	Cfm	RPM	Cfm	RPM							
0	796	39	407	975	69	451	1154	98	494	1298	140	567	1442	181	639	1570	236	692	744	1807	357	785	1917	422	825
0.1	719	44	482	915	76	523	1110	108	564	1257	151	626	1404	193	687	1537	248	733	779	1784	369	815	1898	433	850
0.2	663	49	538	864	83	585	1064	117	633	1220	160	679	1375	203	725	1508	259	770	815	1754	384	853	1866	452	891
0.3	593	55	607	806	91	651	1018	126	695	1174	171	737	1330	216	780	1471	272	815	850	1724	398	890	1835	469	930
0.4	527	60	665	749	97	708	971	135	751	1136	180	783	1300	225	815	1435	285	858	900	1689	413	930	1809	481	959
0.5	460	65	722	692	104	761	924	143	801	1090	190	833	1256	238	866	1398	296	899	932	1662	424	960	1784	493	988
0.6	---	---	---	---	---	---	855	154	864	1033	202	889	1211	250	914	1361	308	939	963	1629	437	995	1746	508	1028
0.7	---	---	---	---	---	---	808	161	898	995	209	922	1181	258	946	1325	319	976	1007	1588	450	1036	1708	522	1065
0.8	---	---	---	---	---	---	743	170	942	940	220	966	1137	269	991	1281	331	1020	1049	1548	463	1074	1670	533	1100
0.9	---	---	---	---	---	---	676	178	979	884	229	1006	1092	280	1033	1237	342	1061	1088	1513	472	1105	1645	539	1121
1.0	---	---	---	---	---	---	605	187	1011	819	240	1049	1032	294	1087	1192	353	1100	1112	1474	480	1137	1595	549	1161
1.1	---	---	---	---	---	---	---	---	---	---	---	988	304	1124	1142	1142	364	1141	1158	1420	490	1177	1544	555	1195
1.2	---	---	---	---	---	---	---	---	---	---	---	---	---	---	---	---	---	---	1189	1373	495	1207	1494	558	1225

HORIZONTAL

External Static Press. in. w.g.	Percentage of Total Motor Torque																								
	20%		30%		40%		50%		60%		70%		80%		90%		100%								
	Cfm	RPM	Cfm	RPM	Cfm	RPM	Cfm	RPM	Cfm	RPM	Cfm	RPM	Cfm	RPM	Cfm	RPM	Cfm	RPM							
0	807	44	372	982	65	431	1157	86	490	1299	126	546	1441	167	602	1565	214	647	692	1795	328	734	1901	393	776
0.1	708	50	468	906	77	513	1103	104	559	1247	143	612	1391	183	666	1522	231	704	742	1766	346	779	1879	413	815
0.2	634	56	541	841	88	583	1048	120	625	1206	156	663	1363	192	701	1491	243	742	783	1731	361	820	1843	429	857
0.3	523	63	648	759	98	669	994	134	690	1150	171	729	1306	209	769	1446	258	796	823	1696	376	860	1807	444	896
0.4	437	69	732	688	107	742	939	146	752	1101	183	785	1263	221	818	1399	273	849	881	1653	392	908	1771	458	935
0.5	344	75	823	615	116	817	885	156	812	1053	194	838	1220	232	865	1361	285	892	918	1614	406	949	1725	473	980
0.6	---	---	---	---	---	---	817	167	883	990	207	905	1162	246	927	1307	301	949	971	1570	420	993	1689	484	1014
0.7	---	---	---	---	---	---	762	174	938	941	215	954	1119	256	971	1269	312	988	1005	1536	430	1026	1653	494	1047
0.8	---	---	---	---	---	---	708	178	991	892	222	1002	1076	266	1013	1222	324	1034	1054	1484	444	1073	1599	506	1092
0.9	---	---	---	---	---	---	645	182	1050	832	230	1059	1019	277	1068	1168	337	1084	1100	1431	456	1117	1545	516	1134
1.0	---	---	---	---	---	---	584	184	1105	780	235	1106	976	285	1107	1122	348	1125	1144	1379	467	1158	1491	522	1172
1.1	---	---	---	---	---	---	---	---	---	---	---	923	295	1155	1169	1217	359	1169	1184	1327	475	1195	1436	526	1207
1.2	---	---	---	---	---	---	---	---	---	---	---	---	---	---	---	---	---	---	1222	1265	481	1234	1364	527	1246

BLOWER DATA - DIRECT DRIVE - O48

BLOWER TABLE INCLUDES RESISTANCE FOR BASE UNIT ONLY WITH DRY INDOOR COIL AND AIR FILTERS IN PLACE.

FOR ALL UNITS ADD:

- 1 - Any factory installed options air resistance (heat section, economizer, etc.).
- 2 - Any field installed accessories air resistance (duct resistance, diffuser, etc.).

See page 39 for wet coil and options/accessory air resistance data.

DOWNFLOW

External Static Press. in. w.g.	Percentage of Total Motor Torque																										
	20%		30%		40%		50%		60%		70%		80%		90%		100%										
	Cfm	Watts	RPM	Cfm	Watts	RPM	Cfm	Watts	RPM	Cfm	Watts	RPM	Cfm	Watts	RPM	Cfm	Watts	RPM	Cfm	Watts	RPM						
0	1048	80	507	1261	135	582	1473	190	657	1655	274	729	1836	359	801	1987	461	863	2137	563	924	2291	698	975	2445	832	1025
0.1	1000	88	560	1218	146	633	1436	204	706	1624	289	771	1812	374	836	1965	479	896	2118	583	956	2261	716	1004	2403	849	1052
0.2	944	97	624	1177	156	683	1409	214	743	1595	304	812	1781	393	881	1940	497	934	2098	602	986	2235	729	1032	2372	856	1077
0.3	906	104	666	1139	166	728	1372	228	790	1561	320	858	1750	412	925	1915	515	970	2079	619	1015	2210	741	1058	2341	863	1100
0.4	849	113	728	1093	177	783	1336	241	837	1531	333	897	1726	425	957	1889	532	1004	2052	639	1051	2177	754	1090	2302	869	1129
0.5	793	121	790	1047	188	837	1300	254	883	1501	346	935	1702	438	987	1864	548	1036	2026	657	1085	2145	766	1120	2263	874	1155
0.6	---	---	---	---	---	---	1263	267	929	1467	361	978	1671	454	1027	1836	564	1071	2000	673	1116	2116	775	1145	2232	876	1175
0.7	---	---	---	---	---	---	1226	280	974	1433	375	1019	1639	470	1065	1807	578	1104	1974	686	1144	2080	782	1173	2186	878	1203
0.8	---	---	---	---	---	---	1195	291	1012	1402	388	1057	1608	485	1101	1778	591	1135	1948	697	1169	2052	787	1195	2155	878	1220
0.9	---	---	---	---	---	---	1162	304	1060	1367	401	1097	1572	498	1134	1741	603	1168	1909	708	1202	2009	792	1223	2109	875	1244
1.0	---	---	---	---	---	---	1133	316	1104	1333	414	1136	1533	511	1167	1702	612	1198	1870	714	1229	1959	791	1251	2047	868	1272
1.1	---	---	---	---	---	---	---	---	---	---	---	---	1490	524	1200	1654	618	1228	1817	713	1256	1909	786	1273	2000	859	1289
1.2	---	---	---	---	---	---	---	---	---	---	---	---	---	---	---	---	---	---	1765	701	1272	1844	771	1293	1923	840	1314

HORIZONTAL

External Static Press. in. w.g.	Percentage of Total Motor Torque																										
	20%		30%		40%		50%		60%		70%		80%		90%		100%										
	Cfm	Watts	RPM	Cfm	Watts	RPM	Cfm	Watts	RPM	Cfm	Watts	RPM	Cfm	Watts	RPM	Cfm	Watts	RPM	Cfm	Watts	RPM	Cfm	Watts	RPM	Cfm	Watts	RPM
0	1025	80	472	1238	131	552	1450	182	632	1626	254	702	1802	326	771	1936	414	824	2071	502	878	2231	634	931	2391	767	983
0.1	978	85	546	1199	138	610	1420	191	675	1601	265	738	1781	339	801	1930	441	862	2079	544	923	2222	663	968	2365	783	1013
0.2	927	89	602	1157	145	661	1387	201	720	1568	279	783	1749	357	845	1906	458	897	2062	559	949	2205	679	993	2348	798	1038
0.3	851	98	684	1098	156	731	1344	214	777	1531	295	833	1717	375	888	1876	478	938	2035	581	988	2166	694	1030	2297	807	1072
0.4	801	105	738	1051	166	785	1300	227	832	1493	309	881	1685	392	930	1847	496	977	2009	600	1023	2128	707	1064	2247	813	1105
0.5	725	118	817	991	179	850	1256	239	883	1455	324	926	1653	408	970	1814	516	1019	1974	623	1068	2091	720	1099	2207	817	1130
0.6	---	---	---	---	---	---	1212	251	931	1417	337	969	1621	423	1008	1784	531	1053	1947	638	1098	2057	729	1126	2166	820	1154
0.7	---	---	---	---	---	---	1169	263	975	1380	350	1010	1590	437	1045	1756	544	1086	1921	651	1127	2014	736	1157	2106	821	1187
0.8	---	---	---	---	---	---	1114	277	1027	1331	366	1059	1547	454	1091	1717	560	1126	1886	666	1161	1976	743	1184	2066	821	1207
0.9	---	---	---	---	---	---	1062	290	1077	1283	380	1106	1504	470	1135	1669	575	1170	1833	680	1204	1919	749	1220	2005	817	1236
1.0	---	---	---	---	---	---	1007	304	1127	1240	392	1147	1473	481	1166	1627	584	1202	1780	687	1238	1853	748	1253	1925	809	1269
1.1	---	---	---	---	---	---	---	---	---	---	---	---	1429	497	1211	1569	590	1240	1709	683	1269	1787	741	1280	1864	799	1291
1.2	---	---	---	---	---	---	---	---	---	---	---	---	---	---	---	---	---	---	1604	651	1284	1684	714	1303	1763	777	1321

BLOWER DATA - DIRECT DRIVE - O60

BLOWER TABLE INCLUDES RESISTANCE FOR BASE UNIT ONLY WITH DRY INDOOR COIL AND AIR FILTERS IN PLACE.

FOR ALL UNITS ADD:

- 1 - Any factory installed options air resistance (heat section, economizer, etc.).
 - 2 - Any field installed accessories air resistance (duct resistance, diffuser, etc.).
- See page 39 for wet coil and options/accessory air resistance data.

DOWNFLOW

External Static Press. in. w.g.	Percentage of Total Motor Torque																										
	20%		30%		40%		50%		60%		70%		80%		90%		100%										
	Cfm	RPM	Cfm	RPM	Cfm	RPM	Cfm	RPM	Cfm	RPM	Cfm	RPM	Cfm	RPM	Cfm	RPM	Cfm	RPM	Cfm	RPM							
0	1132	79	438	1353	146	524	1575	212	610	1765	300	670	1954	388	730	2126	513	796	2298	638	861	2445	792	913	2591	946	965
0.1	1061	86	494	1305	155	568	1548	223	641	1743	315	702	1937	407	764	2110	531	823	2282	654	883	2426	808	935	2570	963	987
0.2	990	94	550	1253	165	614	1516	236	678	1716	330	735	1916	423	793	2088	549	851	2260	675	910	2405	827	959	2549	979	1009
0.3	920	102	606	1202	175	659	1484	248	713	1687	345	770	1890	442	828	2065	568	882	2239	694	937	2384	844	983	2528	994	1030
0.4	849	111	662	1151	185	705	1452	260	747	1658	360	804	1863	460	861	2041	586	911	2218	713	962	2363	861	1006	2508	1009	1050
0.5	779	121	718	1094	198	754	1410	275	790	1626	374	838	1842	473	886	2020	601	936	2197	730	987	2342	876	1028	2487	1023	1070
0.6	---	---	---	---	---	---	1368	289	830	1589	390	876	1810	492	921	1993	619	966	2176	746	1010	2316	895	1054	2456	1043	1099
0.7	---	---	---	---	---	---	1325	303	868	1552	406	911	1778	509	954	1966	635	993	2154	761	1033	2295	908	1075	2435	1055	1117
0.8	---	---	---	---	---	---	1261	321	920	1504	423	952	1746	524	984	1934	653	1024	2122	782	1064	2268	925	1100	2414	1067	1135
0.9	---	---	---	---	---	---	1211	337	964	1462	437	988	1714	538	1012	1902	669	1053	2090	801	1094	2237	942	1127	2383	1084	1161
1.0	---	---	---	---	---	---	1151	354	1013	1412	454	1029	1672	553	1045	1871	682	1078	2069	811	1112	2211	955	1149	2352	1099	1185
1.1	---	---	---	---	---	---	---	---	---	---	---	---	1629	566	1073	1828	698	1109	2027	830	1146	2174	971	1177	2321	1112	1208
1.2	---	---	---	---	---	---	---	---	---	---	---	---	---	---	---	---	---	---	1984	844	1175	2137	984	1202	2290	1124	1230

HORIZONTAL

External Static Press. in. w.g.	Percentage of Total Motor Torque																										
	20%		30%		40%		50%		60%		70%		80%		90%		100%										
	Cfm	RPM	Cfm	RPM	Cfm	RPM	Cfm	RPM	Cfm	RPM	Cfm	RPM	Cfm	RPM	Cfm	RPM	Cfm	RPM	Cfm	RPM	Cfm	RPM	Cfm	RPM	Cfm	RPM	
0	1127	82	426	1367	141	504	1607	200	582	1806	296	644	2005	391	706	2167	495	764	2328	599	822	2463	749	872	2598	899	922
0.1	1071	86	476	1326	148	543	1580	210	610	1781	311	675	1981	411	740	2145	516	795	2309	620	849	2456	775	898	2602	931	947
0.2	1010	91	529	1268	160	598	1525	229	668	1735	332	724	1945	434	781	2117	537	828	2289	640	875	2438	795	921	2587	949	967
0.3	930	100	597	1214	169	647	1497	239	696	1707	345	755	1917	452	814	2093	556	857	2269	660	900	2417	817	948	2565	975	995
0.4	869	109	646	1156	184	699	1442	258	751	1665	364	798	1888	469	845	2066	577	889	2243	685	933	2393	842	978	2543	998	1022
0.5	813	119	689	1114	193	734	1414	267	778	1637	376	827	1860	485	876	2039	597	920	2217	709	963	2373	861	1002	2528	1013	1040
0.6	---	---	---	---	---	---	1358	286	831	1595	394	868	1832	501	905	2012	616	949	2191	731	993	2349	882	1028	2506	1033	1064
0.7	---	---	---	---	---	---	1330	296	857	1560	409	903	1789	523	949	1977	638	985	2164	753	1020	2324	902	1054	2484	1052	1088
0.8	---	---	---	---	---	---	1275	315	908	1518	426	942	1761	536	977	1950	655	1011	2138	773	1046	2296	923	1081	2454	1073	1116
0.9	---	---	---	---	---	---	1233	329	946	1483	439	975	1732	549	1004	1922	670	1037	2112	792	1071	2272	939	1104	2432	1087	1136
1.0	---	---	---	---	---	---	1192	343	982	1441	455	1012	1690	567	1043	1881	692	1074	2072	818	1105	2237	960	1133	2402	1102	1161
1.1	---	---	---	---	---	---	---	---	---	---	---	---	1662	578	1068	1854	706	1097	2046	833	1126	2206	975	1157	2365	1117	1188
1.2	---	---	---	---	---	---	---	---	---	---	---	---	---	---	---	---	---	---	1994	861	1163	2165	993	1185	2336	1125	1206

BLOWER DATA - BELT DRIVE - 036

BLOWER TABLE INCLUDES RESISTANCE FOR BASE UNIT ONLY WITH DRY INDOOR COIL AND AIR FILTERS IN PLACE.

FOR ALL UNITS ADD:

1 - Any factory installed options air resistance (heat section, economizer, etc.).

2 - Any field installed accessories air resistance (duct resistance, diffuser, etc.).

See page 39 for wet coil and options/accessory air resistance data.

DOWNFLOW

Air Volume (cfm)	External Static (in.w.g.)																			
	0.10		0.20		0.30		0.40		0.50		0.60		0.70		0.80		0.9		1.0	
	RPM	BHP	RPM	BHP	RPM	BHP	RPM	BHP	RPM	BHP	RPM	BHP	RPM	BHP	RPM	BHP	RPM	BHP	RPM	BHP
700	453	0.07	523	0.11	596	0.14	679	0.17	762	0.18	828	0.21	878	0.24	927	0.26	979	0.29	1029	0.31
800	471	0.09	542	0.13	614	0.16	696	0.19	777	0.21	841	0.23	889	0.26	938	0.29	990	0.31	1042	0.34
900	493	0.11	563	0.15	634	0.19	715	0.21	793	0.23	854	0.26	902	0.29	950	0.32	1002	0.34	1054	0.36
1000	517	0.14	587	0.18	657	0.21	736	0.24	811	0.26	869	0.29	916	0.32	964	0.35	1015	0.37	1067	0.4
1100	544	0.17	613	0.21	683	0.24	759	0.27	831	0.3	886	0.32	931	0.36	978	0.38	1028	0.41	1078	0.43
1200	574	0.2	643	0.24	711	0.27	784	0.3	852	0.33	904	0.36	947	0.39	993	0.42	1042	0.45	1091	0.47
1300	608	0.24	676	0.28	743	0.31	812	0.34	875	0.37	923	0.4	964	0.44	1010	0.46	1057	0.49	1104	0.51
1400	645	0.28	711	0.31	776	0.35	842	0.38	898	0.41	942	0.44	983	0.48	1028	0.51	1074	0.53	1120	0.56

Air Volume (cfm)	External Static (in.w.g.)																			
	1.1		1.2		1.3		1.4		1.5		1.6		1.7		1.8		1.9		2.0	
	RPM	BHP	RPM	BHP	RPM	BHP	RPM	BHP	RPM	BHP	RPM	BHP	RPM	BHP	RPM	BHP	RPM	BHP	RPM	BHP
700	1078	0.33	1124	0.36	---	---	---	---	---	---	---	---	---	---	---	---	---	---	---	---
800	1091	0.36	1137	0.39	1180	0.41	1221	0.44	1260	0.47	---	---	---	---	---	---	---	---	---	---
900	1105	0.39	1150	0.42	1192	0.45	1232	0.47	1270	0.5	1307	0.53	1345	0.56	1382	0.59	1420	0.62	---	---
1000	1117	0.42	1162	0.45	1203	0.48	1242	0.51	1279	0.54	1316	0.57	1353	0.6	1390	0.63	1427	0.66	1465	0.7
1100	1126	0.46	1171	0.49	1212	0.52	1251	0.56	1288	0.59	1325	0.62	1361	0.65	1397	0.68	1433	0.71	1470	0.75
1200	1137	0.5	1180	0.54	1222	0.57	1260	0.6	1298	0.64	1334	0.67	1369	0.7	1404	0.73	1440	0.77	1477	0.8
1300	1149	0.55	1191	0.58	1232	0.62	1270	0.65	1307	0.69	1343	0.72	1378	0.76	1413	0.79	1449	0.82	1486	0.86
1400	1163	0.6	1204	0.63	1243	0.67	1281	0.71	1317	0.74	1353	0.78	1388	0.82	1423	0.85	1459	0.89	1496	0.92

BLOWER DATA - BELT DRIVE - 036

BLOWER TABLE INCLUDES RESISTANCE FOR BASE UNIT ONLY WITH DRY INDOOR COIL AND AIR FILTERS IN PLACE.

FOR ALL UNITS ADD:

1 - Any factory installed options air resistance (heat section, economizer, etc.).

2 - Any field installed accessories air resistance (duct resistance, diffuser, etc.).

See page 39 for blower motors and drives and wet coil and options/accessory air resistance data.

HORIZONTAL

Air Volume (cfm)	External Static (in.w.g.)																			
	0.10		0.20		0.30		0.40		0.50		0.60		0.70		0.80		0.9		1.0	
	RPM	BHP	RPM	BHP	RPM	BHP	RPM	BHP	RPM	BHP	RPM	BHP	RPM	BHP	RPM	BHP	RPM	BHP	RPM	BHP
700	440	0.07	510	0.1	585	0.12	657	0.14	726	0.17	793	0.2	856	0.23	915	0.25	967	0.28	1016	0.31
800	456	0.08	526	0.11	600	0.14	672	0.16	739	0.19	804	0.22	866	0.25	923	0.28	975	0.31	1025	0.34
900	474	0.1	544	0.13	617	0.16	688	0.18	754	0.21	818	0.24	877	0.27	932	0.3	984	0.33	1034	0.36
1000	495	0.12	565	0.15	637	0.18	707	0.21	771	0.23	832	0.27	889	0.3	943	0.33	993	0.36	1043	0.39
1100	518	0.14	588	0.18	659	0.21	727	0.23	789	0.26	848	0.3	903	0.33	954	0.37	1003	0.4	1052	0.43
1200	544	0.17	613	0.21	682	0.24	748	0.27	809	0.29	866	0.33	918	0.37	967	0.4	1014	0.43	1062	0.46
1300	572	0.21	640	0.24	707	0.27	771	0.3	830	0.33	884	0.37	934	0.41	981	0.44	1027	0.47	1073	0.5
1400	602	0.24	669	0.28	733	0.31	795	0.34	851	0.37	903	0.41	950	0.45	995	0.49	1040	0.52	1086	0.55

Air Volume (cfm)	External Static (in.w.g.)																			
	1.1		1.2		1.3		1.4		1.5		1.6		1.7		1.8		1.9		2.0	
	RPM	BHP	RPM	BHP	RPM	BHP	RPM	BHP	RPM	BHP	RPM	BHP	RPM	BHP	RPM	BHP	RPM	BHP	RPM	BHP
700	1065	0.33	---	---	---	---	---	---	---	---	---	---	---	---	---	---	---	---	---	---
800	1075	0.36	1122	0.39	1164	0.42	1203	0.45	1241	0.47	---	---	---	---	---	---	---	---	---	---
900	1086	0.39	1133	0.42	1174	0.45	1213	0.48	1250	0.51	1286	0.54	1322	0.57	1357	0.6	1392	0.64	---	---
1000	1094	0.43	1142	0.46	1183	0.49	1222	0.52	1259	0.55	1295	0.58	1330	0.62	1365	0.65	1400	0.68	1435	0.71
1100	1102	0.46	1148	0.49	1191	0.53	1230	0.56	1267	0.6	1303	0.63	1338	0.66	1373	0.69	1408	0.73	1444	0.76
1200	1110	0.5	1156	0.53	1198	0.57	1238	0.61	1275	0.64	1311	0.68	1346	0.71	1381	0.74	1416	0.78	1452	0.81
1300	1120	0.54	1164	0.58	1207	0.62	1246	0.65	1283	0.69	1319	0.73	1354	0.76	1389	0.79	1424	0.83	1460	0.86
1400	1131	0.59	1175	0.63	1216	0.67	1255	0.7	1292	0.74	1327	0.78	1362	0.81	1397	0.84	1432	0.88	1468	0.91

BLOWER DATA - BELT DRIVE - 048

BLOWER TABLE INCLUDES RESISTANCE FOR BASE UNIT ONLY WITH DRY INDOOR COIL AND AIR FILTERS IN PLACE.

FOR ALL UNITS ADD:

1 - Any factory installed options air resistance (heat section, economizer, etc.).

2 - Any field installed accessories air resistance (duct resistance, diffuser, etc.).

See page 39 for blower motors and drives and wet coil and options/accessory air resistance data.

DOWNFLOW

Air Volume (cfm)	External Static (in.w.g.)																			
	0.10		0.20		0.30		0.40		0.50		0.60		0.70		0.80		0.9		1.0	
	RPM	BHP	RPM	BHP	RPM	BHP	RPM	BHP	RPM	BHP	RPM	BHP	RPM	BHP	RPM	BHP	RPM	BHP	RPM	BHP
900	502	0.12	573	0.15	644	0.19	725	0.22	802	0.24	861	0.26	908	0.29	957	0.32	1009	0.34	1061	0.37
1000	528	0.14	598	0.18	668	0.22	747	0.24	821	0.27	877	0.3	923	0.33	971	0.35	1022	0.38	1074	0.4
1100	557	0.17	626	0.21	695	0.25	772	0.28	841	0.3	894	0.33	939	0.36	986	0.39	1037	0.41	1087	0.44
1200	589	0.21	657	0.25	725	0.28	798	0.31	864	0.33	913	0.37	956	0.4	1003	0.43	1052	0.45	1100	0.48
1300	625	0.25	692	0.28	759	0.32	827	0.34	887	0.37	933	0.41	975	0.44	1021	0.47	1068	0.49	1115	0.52
1400	665	0.29	730	0.32	794	0.35	857	0.38	911	0.42	953	0.45	995	0.49	1040	0.52	1086	0.54	1131	0.57
1500	706	0.33	768	0.36	829	0.39	886	0.43	934	0.46	974	0.5	1015	0.54	1060	0.56	1105	0.59	1149	0.62
1600	746	0.37	805	0.4	862	0.44	914	0.48	957	0.52	996	0.55	1037	0.59	1081	0.62	1126	0.64	1167	0.68
1700	784	0.42	840	0.45	893	0.49	940	0.53	980	0.57	1019	0.61	1060	0.64	1104	0.67	1147	0.7	1187	0.74
1800	821	0.47	874	0.51	923	0.55	967	0.59	1006	0.63	1044	0.67	1085	0.7	1128	0.73	1170	0.77	1208	0.82
1900	857	0.53	906	0.57	952	0.62	994	0.66	1032	0.7	1071	0.73	1112	0.76	1154	0.8	1194	0.85	1230	0.9

Air Volume (cfm)	External Static (in.w.g.)																			
	1.1		1.2		1.3		1.4		1.5		1.6		1.7		1.8		1.9		2.0	
	RPM	BHP	RPM	BHP	RPM	BHP	RPM	BHP	RPM	BHP	RPM	BHP	RPM	BHP	RPM	BHP	RPM	BHP	RPM	BHP
900	1111	0.39	1156	0.42	1197	0.45	1236	0.48	1275	0.51	1312	0.54	1349	0.56	1387	0.59	1424	0.62	---	---
1000	1124	0.43	1168	0.46	1209	0.49	1247	0.52	1285	0.55	1322	0.58	1358	0.61	1395	0.64	1432	0.67	1470	0.7
1100	1134	0.47	1178	0.5	1219	0.53	1258	0.56	1295	0.6	1331	0.63	1367	0.66	1403	0.69	1439	0.72	1477	0.75
1200	1146	0.51	1189	0.54	1230	0.58	1268	0.61	1305	0.65	1341	0.68	1376	0.71	1411	0.74	1447	0.77	1485	0.81
1300	1159	0.55	1201	0.59	1241	0.63	1279	0.66	1315	0.7	1351	0.73	1386	0.77	1421	0.8	1457	0.83	1495	0.87
1400	1173	0.61	1214	0.64	1253	0.68	1290	0.72	1327	0.75	1362	0.79	1397	0.82	1432	0.86	1468	0.89	1506	0.93
1500	1189	0.66	1228	0.7	1266	0.74	1303	0.78	1339	0.81	1374	0.85	1409	0.89	1445	0.92	1481	0.96	1519	1
1600	1206	0.72	1244	0.76	1281	0.8	1317	0.84	1353	0.88	1388	0.92	1423	0.96	1459	1	1496	1.04	1535	1.08
1700	1224	0.79	1261	0.83	1298	0.87	1334	0.91	1369	0.95	1404	0.99	1440	1.03	1476	1.07	1513	1.12	1552	1.16
1800	1244	0.86	1280	0.91	1316	0.95	1352	0.99	1387	1.03	1422	1.07	1457	1.11	1494	1.16	1532	1.2	1570	1.24
1900	1265	0.95	1301	1	1336	1.04	1371	1.08	1406	1.12	1441	1.16	1477	1.2	1515	1.24	1553	1.29	1592	1.33

BLOWER DATA - BELT DRIVE - 048

BLOWER TABLE INCLUDES RESISTANCE FOR BASE UNIT ONLY WITH DRY INDOOR COIL AND AIR FILTERS IN PLACE.

FOR ALL UNITS ADD:

1 - Any factory installed options air resistance (heat section, economizer, etc.).

2 - Any field installed accessories air resistance (duct resistance, diffuser, etc.).

See page 39 for blower motors and drives and wet coil and options/accessory air resistance data.

HORIZONTAL

Air Volume (cfm)	External Static (in.w.g.)																			
	0.10		0.20		0.30		0.40		0.50		0.60		0.70		0.80		0.9		1.0	
	RPM	BHP	RPM	BHP	RPM	BHP	RPM	BHP	RPM	BHP	RPM	BHP	RPM	BHP	RPM	BHP	RPM	BHP	RPM	BHP
900	483	0.1	554	0.13	627	0.16	699	0.19	765	0.22	826	0.24	882	0.27	935	0.3	986	0.33	1039	0.36
1000	505	0.12	576	0.16	648	0.19	719	0.21	784	0.24	842	0.27	896	0.3	947	0.33	998	0.37	1050	0.4
1100	530	0.15	601	0.18	671	0.21	741	0.24	804	0.27	860	0.3	912	0.34	961	0.37	1010	0.4	1060	0.43
1200	558	0.18	627	0.22	696	0.25	764	0.28	824	0.3	878	0.34	928	0.37	975	0.41	1023	0.44	1072	0.47
1300	588	0.22	656	0.25	723	0.28	788	0.31	846	0.34	897	0.38	945	0.42	990	0.45	1037	0.48	1084	0.51
1400	621	0.25	687	0.29	752	0.32	814	0.35	868	0.38	916	0.42	962	0.46	1006	0.5	1052	0.53	1098	0.56
1500	655	0.29	719	0.33	781	0.36	839	0.39	890	0.43	936	0.47	979	0.51	1023	0.55	1068	0.58	1113	0.61
1600	690	0.33	751	0.37	810	0.4	865	0.44	912	0.48	955	0.52	997	0.56	1041	0.6	1086	0.63	1129	0.66
1700	725	0.38	784	0.41	839	0.45	891	0.49	935	0.53	975	0.58	1017	0.62	1060	0.65	1104	0.68	1147	0.72
1800	761	0.42	816	0.46	868	0.5	916	0.55	957	0.59	997	0.64	1038	0.68	1081	0.71	1124	0.74	1165	0.79
1900	795	0.48	848	0.52	897	0.56	942	0.61	981	0.66	1020	0.7	1060	0.74	1103	0.77	1145	0.81	1183	0.85

Air Volume (cfm)	External Static (in.w.g.)																			
	1.1		1.2		1.3		1.4		1.5		1.6		1.7		1.8		1.9		2.0	
	RPM	BHP	RPM	BHP	RPM	BHP	RPM	BHP	RPM	BHP	RPM	BHP	RPM	BHP	RPM	BHP	RPM	BHP	RPM	BHP
900	1091	0.4	1138	0.43	1180	0.46	1220	0.49	1257	0.53	1293	0.56	1329	0.59	1364	0.62	1400	0.65	1435	0.69
1000	1101	0.43	1149	0.46	1190	0.5	1229	0.53	1266	0.57	1302	0.6	1338	0.63	1373	0.66	1408	0.7	1444	0.73
1100	1110	0.46	1156	0.5	1199	0.54	1238	0.57	1275	0.61	1311	0.64	1346	0.67	1381	0.71	1416	0.74	1452	0.78
1200	1119	0.5	1165	0.54	1207	0.58	1247	0.62	1284	0.65	1319	0.69	1355	0.72	1389	0.75	1425	0.79	1460	0.82
1300	1130	0.55	1175	0.59	1216	0.63	1255	0.66	1292	0.7	1328	0.74	1363	0.77	1398	0.8	1433	0.84	1469	0.87
1400	1143	0.6	1186	0.63	1226	0.67	1265	0.71	1302	0.75	1337	0.79	1372	0.82	1406	0.85	1441	0.89	1477	0.93
1500	1156	0.65	1198	0.69	1237	0.73	1275	0.77	1311	0.8	1346	0.84	1381	0.88	1415	0.91	1450	0.95	1486	0.98
1600	1171	0.7	1211	0.74	1249	0.78	1286	0.82	1321	0.86	1356	0.9	1390	0.93	1425	0.97	1460	1.01	1496	1.05
1700	1186	0.76	1225	0.8	1262	0.84	1298	0.88	1333	0.92	1367	0.96	1401	1	1436	1.03	1471	1.07	1507	1.12
1800	1202	0.83	1240	0.87	1276	0.91	1311	0.95	1345	0.99	1380	1.03	1413	1.07	1448	1.11	1483	1.15	1520	1.19
1900	1220	0.9	1256	0.94	1291	0.99	1326	1.03	1360	1.07	1393	1.1	1427	1.14	1462	1.18	1497	1.22	1534	1.27

BLOWER DATA - BELT DRIVE - 060

BLOWER TABLE INCLUDES RESISTANCE FOR BASE UNIT ONLY WITH DRY INDOOR COIL AND AIR FILTERS IN PLACE.

FOR ALL UNITS ADD:

1 - Any factory installed options air resistance (heat section, economizer, etc.).

2 - Any field installed accessories air resistance (duct resistance, diffuser, etc.).

See page 39 for blower motors and drives and wet coil and options/accessory air resistance data.

DOWNFLOW

Air Volume (cfm)	External Static (in.w.g.)																			
	0.10		0.20		0.30		0.40		0.50		0.60		0.70		0.80		0.9		1.0	
	RPM	BHP	RPM	BHP	RPM	BHP	RPM	BHP	RPM	BHP	RPM	BHP	RPM	BHP	RPM	BHP	RPM	BHP	RPM	BHP
1100	529	0.17	591	0.21	653	0.24	724	0.26	810	0.26	886	0.26	942	0.28	982	0.32	1022	0.36	1064	0.40
1200	553	0.20	615	0.24	677	0.27	747	0.30	829	0.30	902	0.30	955	0.33	994	0.36	1034	0.40	1075	0.44
1300	579	0.23	640	0.27	701	0.31	770	0.33	850	0.34	918	0.35	969	0.37	1007	0.41	1047	0.45	1088	0.49
1400	609	0.27	669	0.31	729	0.34	796	0.37	871	0.38	936	0.39	983	0.41	1022	0.45	1061	0.49	1102	0.53
1500	658	0.28	715	0.32	771	0.36	832	0.39	898	0.41	955	0.43	999	0.46	1037	0.50	1077	0.54	1117	0.58
1600	720	0.28	769	0.33	819	0.37	871	0.41	926	0.44	975	0.47	1016	0.51	1054	0.55	1093	0.60	1133	0.63
1700	779	0.30	822	0.35	864	0.39	908	0.44	953	0.48	995	0.52	1034	0.57	1072	0.61	1111	0.65	1150	0.69
1800	828	0.34	864	0.39	901	0.43	938	0.48	977	0.53	1015	0.58	1053	0.63	1091	0.67	1130	0.71	1169	0.75
1900	857	0.41	892	0.45	927	0.50	962	0.55	999	0.60	1036	0.65	1074	0.69	1112	0.73	1150	0.77	1188	0.81
2000	879	0.47	913	0.52	948	0.56	984	0.61	1020	0.67	1058	0.72	1096	0.76	1134	0.80	1172	0.84	1210	0.88
2100	900	0.53	935	0.58	970	0.63	1007	0.69	1044	0.74	1081	0.79	1119	0.84	1157	0.88	1195	0.91	1233	0.95
2200	922	0.60	958	0.65	994	0.71	1031	0.76	1068	0.82	1106	0.87	1143	0.91	1180	0.95	1218	0.99	1255	1.03
2300	947	0.67	983	0.73	1020	0.79	1057	0.85	1094	0.90	1131	0.95	1168	1.00	1205	1.03	1242	1.07	1277	1.13
2400	974	0.76	1010	0.82	1047	0.88	1084	0.94	1120	0.99	1157	1.04	1193	1.08	1230	1.12	1267	1.16	1300	1.23

Air Volume (cfm)	External Static (in.w.g.)																			
	1.1		1.2		1.3		1.4		1.5		1.6		1.7		1.8		1.9		2.0	
	RPM	BHP	RPM	BHP	RPM	BHP	RPM	BHP	RPM	BHP	RPM	BHP	RPM	BHP	RPM	BHP	RPM	BHP	RPM	BHP
1100	1106	0.44	1151	0.47	1197	0.49	1238	0.52	1272	0.56	---	---	---	---	---	---	---	---	---	---
1200	1117	0.48	1161	0.51	1206	0.53	1245	0.57	1278	0.60	1312	0.64	1346	0.67	1380	0.71	---	---	---	---
1300	1129	0.52	1172	0.55	1216	0.58	1254	0.61	1287	0.65	1320	0.69	1354	0.72	1388	0.76	1421	0.79	1455	0.82
1400	1143	0.57	1185	0.60	1227	0.63	1264	0.66	1296	0.70	1329	0.74	1363	0.77	1397	0.81	1430	0.85	1464	0.88
1500	1157	0.62	1199	0.65	1239	0.68	1275	0.71	1306	0.75	1339	0.79	1373	0.83	1406	0.87	1440	0.90	1473	0.94
1600	1173	0.67	1214	0.70	1253	0.73	1288	0.77	1318	0.81	1351	0.85	1384	0.89	1417	0.93	1451	0.96	1484	1.00
1700	1190	0.72	1230	0.76	1268	0.79	1301	0.83	1331	0.87	1363	0.92	1396	0.95	1429	0.99	1462	1.03	1495	1.07
1800	1208	0.78	1247	0.82	1285	0.86	1317	0.90	1345	0.94	1377	0.98	1410	1.02	1442	1.06	1475	1.10	1508	1.14
1900	1227	0.85	1267	0.88	1303	0.92	1333	0.97	1360	1.02	1392	1.06	1424	1.10	1457	1.14	1489	1.18	1522	1.22
2000	1248	0.92	1286	0.96	1321	1.00	1350	1.05	1377	1.10	1409	1.14	1441	1.18	1473	1.22	1505	1.26	1537	1.30
2100	1269	1.00	1306	1.04	1339	1.09	1367	1.14	1395	1.19	1426	1.23	1458	1.27	1490	1.31	1522	1.35	1554	1.39
2200	1290	1.09	1324	1.14	1356	1.19	1385	1.24	1413	1.28	1444	1.32	1476	1.36	1508	1.41	1540	1.45	1572	1.49
2300	1310	1.20	1343	1.26	1374	1.30	1403	1.34	1432	1.38	1464	1.42	1495	1.46	1527	1.51	1559	1.55	1591	1.59
2400	1332	1.31	1364	1.37	1394	1.41	1423	1.45	1453	1.48	1484	1.53	1516	1.57	1547	1.61	1579	1.65	1612	1.70

BLOWER DATA - BELT DRIVE - 060

BLOWER TABLE INCLUDES RESISTANCE FOR BASE UNIT ONLY WITH DRY INDOOR COIL AND AIR FILTERS IN PLACE.

FOR ALL UNITS ADD:

1 - Any factory installed options air resistance (heat section, economizer, etc.).

2 - Any field installed accessories air resistance (duct resistance, diffuser, etc.).

See page 39 for blower motors and drives and wet coil and options/accessory air resistance data.

HORIZONTAL

Air Volume (cfm)	External Static (in.w.g.)																			
	0.10		0.20		0.30		0.40		0.50		0.60		0.70		0.80		0.9		1.0	
	RPM	BHP	RPM	BHP	RPM	BHP	RPM	BHP	RPM	BHP	RPM	BHP	RPM	BHP	RPM	BHP	RPM	BHP	RPM	BHP
1100	503	0.14	569	0.17	636	0.20	703	0.23	769	0.26	842	0.28	909	0.30	964	0.33	1008	0.36	1049	0.40
1200	525	0.16	590	0.20	657	0.23	722	0.26	787	0.29	857	0.31	921	0.34	974	0.37	1016	0.40	1056	0.43
1300	548	0.19	613	0.23	679	0.26	743	0.29	806	0.32	873	0.35	934	0.37	984	0.41	1026	0.44	1065	0.47
1400	574	0.22	638	0.26	702	0.30	765	0.33	827	0.36	891	0.39	949	0.41	996	0.45	1037	0.48	1076	0.51
1500	609	0.25	671	0.29	733	0.33	793	0.36	851	0.39	911	0.42	965	0.46	1010	0.49	1049	0.53	1088	0.56
1600	654	0.28	712	0.32	769	0.36	825	0.39	879	0.43	933	0.47	982	0.50	1024	0.54	1063	0.58	1101	0.61
1700	703	0.31	756	0.35	807	0.39	858	0.43	906	0.47	955	0.51	999	0.55	1039	0.59	1078	0.63	1117	0.66
1800	752	0.34	798	0.38	844	0.43	889	0.48	933	0.52	977	0.57	1017	0.61	1056	0.65	1094	0.68	1133	0.72
1900	796	0.38	837	0.43	878	0.48	918	0.53	958	0.58	997	0.62	1036	0.67	1074	0.71	1112	0.74	1151	0.77
2000	833	0.43	870	0.48	907	0.54	943	0.59	980	0.64	1018	0.69	1055	0.73	1093	0.77	1131	0.80	1170	0.83
2100	864	0.50	897	0.55	931	0.60	966	0.65	1002	0.71	1038	0.76	1075	0.80	1113	0.83	1151	0.87	1189	0.90
2200	887	0.57	920	0.62	953	0.67	988	0.73	1024	0.78	1060	0.83	1097	0.87	1135	0.90	1173	0.94	1210	0.98
2300	909	0.64	942	0.70	976	0.75	1011	0.81	1046	0.86	1083	0.91	1120	0.95	1157	0.98	1195	1.02	1231	1.06
2400	931	0.72	965	0.78	999	0.83	1035	0.89	1071	0.94	1108	0.99	1144	1.03	1181	1.07	1217	1.10	1252	1.15

Air Volume (cfm)	External Static (in.w.g.)																			
	1.1		1.2		1.3		1.4		1.5		1.6		1.7		1.8		1.9		2.0	
	RPM	BHP	RPM	BHP	RPM	BHP	RPM	BHP	RPM	BHP	RPM	BHP	RPM	BHP	RPM	BHP	RPM	BHP	RPM	BHP
1100	1090	0.42	1132	0.45	1175	0.47	1216	0.50	1257	0.53	1296	0.56	1334	0.59	1370	0.62	1405	0.65	1439	0.69
1200	1097	0.46	1139	0.49	1181	0.51	1222	0.54	1263	0.57	1301	0.60	1338	0.63	1374	0.67	1409	0.70	1443	0.74
1300	1106	0.50	1147	0.53	1189	0.55	1230	0.58	1270	0.61	1307	0.65	1344	0.68	1379	0.72	1414	0.75	1447	0.79
1400	1116	0.54	1157	0.57	1198	0.60	1239	0.63	1278	0.66	1315	0.70	1351	0.74	1385	0.77	1419	0.81	1452	0.85
1500	1128	0.59	1168	0.62	1209	0.64	1249	0.68	1287	0.71	1323	0.75	1358	0.79	1393	0.83	1426	0.87	1458	0.91
1600	1141	0.64	1181	0.67	1222	0.70	1261	0.73	1298	0.77	1333	0.81	1367	0.85	1401	0.89	1433	0.93	1465	0.97
1700	1156	0.69	1196	0.72	1235	0.75	1273	0.79	1309	0.83	1344	0.87	1377	0.91	1410	0.96	1442	1.00	1473	1.04
1800	1172	0.75	1211	0.78	1250	0.81	1287	0.85	1322	0.90	1355	0.94	1388	0.98	1420	1.02	1451	1.07	1482	1.11
1900	1190	0.81	1228	0.84	1265	0.88	1301	0.92	1335	0.97	1367	1.01	1399	1.05	1431	1.10	1462	1.14	1492	1.18
2000	1208	0.87	1245	0.91	1281	0.96	1316	1.00	1349	1.04	1380	1.09	1412	1.13	1443	1.18	1473	1.22	1503	1.26
2100	1227	0.94	1263	0.99	1298	1.04	1331	1.08	1363	1.13	1394	1.17	1425	1.22	1455	1.26	1485	1.31	1515	1.35
2200	1246	1.02	1281	1.07	1315	1.12	1347	1.17	1379	1.22	1409	1.26	1439	1.31	1469	1.36	1499	1.40	1529	1.45
2300	1266	1.11	1300	1.16	1333	1.22	1364	1.27	1395	1.32	1424	1.36	1454	1.41	1484	1.46	1513	1.50	1543	1.55
2400	1286	1.20	1319	1.26	1351	1.32	1382	1.38	1411	1.43	1440	1.48	1470	1.52	1499	1.57	1528	1.61	1558	1.66

BLOWER DATA - BELT DRIVE - 072/074

BLOWER TABLE INCLUDES RESISTANCE FOR BASE UNIT ONLY WITH DRY INDOOR COIL AND AIR FILTERS IN PLACE.

FOR ALL UNITS ADD:

- 1 - Any factory installed options air resistance (heat section, economizer, etc.).
- 2 - Any field installed accessories air resistance (duct resistance, diffuser, etc.).

See page 39 for blower motors and drives and wet coil and options/accessory air resistance data.

DOWNFLOW

Air Volume (cfm)	External Static (in.w.g.)																			
	0.10		0.20		0.30		0.40		0.50		0.60		0.70		0.80		0.9		1.0	
	RPM	BHP	RPM	BHP	RPM	BHP	RPM	BHP	RPM	BHP	RPM	BHP	RPM	BHP	RPM	BHP	RPM	BHP	RPM	BHP
1900	510	0.45	544	0.5	579	0.55	614	0.6	649	0.65	684	0.7	718	0.74	752	0.79	784	0.83	812	0.88
2000	526	0.49	560	0.55	595	0.6	629	0.65	663	0.7	697	0.75	730	0.79	763	0.84	794	0.88	820	0.93
2100	542	0.54	576	0.59	610	0.65	644	0.7	678	0.75	711	0.8	743	0.84	775	0.89	804	0.94	830	0.98
2200	560	0.59	593	0.64	627	0.7	660	0.75	693	0.8	725	0.85	757	0.9	787	0.94	814	0.99	840	1.03
2300	578	0.64	610	0.7	644	0.75	676	0.81	709	0.86	740	0.91	770	0.95	799	1	826	1.05	851	1.09
2400	597	0.7	629	0.75	661	0.81	693	0.86	725	0.91	755	0.96	784	1.01	812	1.06	838	1.11	862	1.15
2500	617	0.76	648	0.81	679	0.87	710	0.92	741	0.97	770	1.03	799	1.08	825	1.13	850	1.17	875	1.22
2600	637	0.82	667	0.87	698	0.93	728	0.98	758	1.04	786	1.09	814	1.15	839	1.2	864	1.24	887	1.28
2700	658	0.88	687	0.94	717	1	746	1.05	775	1.11	802	1.16	829	1.22	853	1.27	877	1.31	901	1.36
2800	679	0.95	708	1.01	736	1.07	764	1.12	792	1.18	819	1.24	844	1.3	868	1.35	892	1.39	915	1.43
2900	701	1.02	728	1.08	756	1.14	783	1.2	809	1.26	835	1.32	860	1.38	884	1.43	907	1.47	930	1.52

Air Volume (cfm)	External Static (in.w.g.)																			
	1.1		1.2		1.3		1.4		1.5		1.6		1.7		1.8		1.9		2.0	
	RPM	BHP	RPM	BHP	RPM	BHP	RPM	BHP	RPM	BHP	RPM	BHP	RPM	BHP	RPM	BHP	RPM	BHP	RPM	BHP
1900	837	0.92	861	0.96	886	1	913	1.04	939	1.07	966	1.11	992	1.16	1017	1.21	1041	1.27	1065	1.33
2000	845	0.97	870	1.01	895	1.05	921	1.09	948	1.12	974	1.17	999	1.22	1023	1.27	1047	1.33	1070	1.39
2100	855	1.02	879	1.06	904	1.1	930	1.14	956	1.18	982	1.22	1006	1.28	1030	1.34	1053	1.4	1075	1.46
2200	865	1.08	889	1.12	914	1.15	940	1.19	966	1.24	990	1.29	1014	1.34	1037	1.41	1059	1.47	1081	1.54
2300	875	1.13	900	1.17	925	1.21	951	1.25	976	1.3	999	1.35	1022	1.41	1044	1.48	1066	1.55	1087	1.62
2400	887	1.19	912	1.23	936	1.27	961	1.32	986	1.37	1009	1.43	1031	1.49	1052	1.57	1073	1.64	1094	1.71
2500	899	1.25	923	1.29	948	1.34	973	1.39	996	1.44	1018	1.51	1039	1.58	1060	1.65	1080	1.73	1101	1.8
2600	912	1.32	936	1.36	960	1.41	984	1.46	1007	1.52	1028	1.59	1049	1.67	1069	1.75	1089	1.82	1109	1.89
2700	925	1.4	949	1.44	973	1.49	996	1.55	1018	1.61	1038	1.69	1058	1.76	1078	1.84	1098	1.92	1118	1.99
2800	939	1.47	962	1.52	985	1.57	1008	1.64	1029	1.71	1049	1.79	1069	1.87	1088	1.94	1107	2.02	1127	2.09
2900	953	1.56	976	1.61	998	1.67	1020	1.73	1041	1.81	1060	1.89	1079	1.98	1098	2.06	1117	2.13	1137	2.21

BLOWER DATA - BELT DRIVE - 072/074

BLOWER TABLE INCLUDES RESISTANCE FOR BASE UNIT ONLY WITH DRY INDOOR COIL AND AIR FILTERS IN PLACE.

FOR ALL UNITS ADD:

1 - Any factory installed options air resistance (heat section, economizer, etc.).

2 - Any field installed accessories air resistance (duct resistance, diffuser, etc.).

See page 39 for blower motors and drives and wet coil and options/accessory air resistance data.

HORIZONTAL

Air Volume (cfm)	External Static (in.w.g.)																			
	0.10		0.20		0.30		0.40		0.50		0.60		0.70		0.80		0.9		1.0	
	RPM	BHP	RPM	BHP	RPM	BHP	RPM	BHP	RPM	BHP	RPM	BHP	RPM	BHP	RPM	BHP	RPM	BHP	RPM	BHP
1900	485	0.55	516	0.57	549	0.59	583	0.62	618	0.65	654	0.69	689	0.73	724	0.77	758	0.82	790	0.86
2000	499	0.59	531	0.61	563	0.63	597	0.66	631	0.7	666	0.73	701	0.77	734	0.82	767	0.86	798	0.91
2100	514	0.63	546	0.65	578	0.68	611	0.71	645	0.74	679	0.78	712	0.82	745	0.86	777	0.91	806	0.96
2200	530	0.68	562	0.7	594	0.73	627	0.76	660	0.79	693	0.83	725	0.87	757	0.92	787	0.96	816	1.01
2300	548	0.73	579	0.75	610	0.78	643	0.81	675	0.85	707	0.88	738	0.93	769	0.97	798	1.02	826	1.06
2400	566	0.78	596	0.81	628	0.84	659	0.87	691	0.9	722	0.94	752	0.98	782	1.03	810	1.08	837	1.12
2500	585	0.84	615	0.86	645	0.9	676	0.93	707	0.96	737	1	767	1.05	795	1.09	822	1.14	848	1.19
2600	604	0.9	634	0.93	664	0.96	694	0.99	724	1.03	753	1.07	781	1.11	809	1.15	835	1.2	861	1.25
2700	624	0.96	653	0.99	682	1.02	712	1.06	741	1.09	769	1.13	796	1.18	823	1.22	849	1.27	873	1.32
2800	645	1.02	673	1.05	701	1.09	730	1.12	758	1.16	785	1.2	812	1.25	838	1.29	862	1.34	886	1.39
2900	665	1.09	693	1.12	721	1.16	748	1.19	775	1.23	802	1.27	827	1.32	852	1.36	877	1.41	900	1.46

Air Volume (cfm)	External Static (in.w.g.)																			
	1.1		1.2		1.3		1.4		1.5		1.6		1.7		1.8		1.9		2.0	
	RPM	BHP	RPM	BHP	RPM	BHP	RPM	BHP	RPM	BHP	RPM	BHP	RPM	BHP	RPM	BHP	RPM	BHP	RPM	BHP
1900	819	0.9	846	0.94	871	0.98	897	1.02	922	1.05	948	1.09	974	1.13	999	1.18	1025	1.23	1050	1.28
2000	826	0.95	852	0.99	877	1.03	902	1.06	928	1.1	953	1.14	979	1.18	1004	1.23	1029	1.28	1054	1.34
2100	834	1	859	1.04	884	1.08	909	1.12	934	1.15	960	1.2	985	1.24	1010	1.29	1034	1.35	1058	1.4
2200	842	1.05	868	1.1	892	1.13	917	1.17	942	1.21	967	1.26	992	1.3	1016	1.36	1040	1.41	1063	1.47
2300	852	1.11	877	1.15	901	1.19	926	1.23	950	1.27	975	1.32	999	1.37	1023	1.42	1046	1.48	1069	1.54
2400	862	1.17	887	1.21	911	1.25	935	1.3	959	1.34	983	1.39	1007	1.44	1030	1.5	1053	1.56	1075	1.62
2500	873	1.23	897	1.28	921	1.32	945	1.36	969	1.41	992	1.46	1016	1.52	1038	1.58	1060	1.64	1082	1.7
2600	885	1.3	909	1.34	932	1.39	955	1.43	979	1.49	1002	1.54	1025	1.6	1047	1.66	1069	1.73	1090	1.79
2700	897	1.37	920	1.41	944	1.46	967	1.51	990	1.57	1012	1.62	1034	1.69	1056	1.75	1077	1.82	1098	1.89
2800	910	1.44	933	1.49	955	1.54	978	1.6	1001	1.65	1023	1.72	1044	1.78	1066	1.85	1086	1.92	1107	1.99
2900	923	1.52	945	1.57	968	1.63	990	1.68	1012	1.75	1034	1.81	1055	1.88	1076	1.95	1096	2.02	1116	2.09

BLOWER DATA

BELT DRIVE KIT SPECIFICATIONS - 036-060

Model No.	Motor HP		No. of Speeds	Drive Kits and RPM Range					
	Nominal	Maximum		A01	A02	A03	A05	A06	A07
036	0.75	0.86	2	low 449-673 high 673-1010	---	---	---	---	---
	1	1.15	2	---	---	---	low 598-897 high 897-1346	---	---
048	0.75	0.86	2	---	low 497-673 high 745-1117	---	---	---	---
	2	2.3	2	---	---	---	---	low 714-953 high 1071-1429	---
060	1	1.15	2	---	---	low 555-833 high 833-1250	---	---	---
	2	2.3	2	---	---	---	---	---	low 808-1032 high 1212-1548

BELT DRIVE KIT SPECIFICATIONS - 072-074

Model No.	Motor HP		No. of Speeds	Drive Kits and RPM Range		
	Nominal	Maximum		AA01	AA02	AA03
072	1	1.15	1	522-784	---	---
	2	2.3	1	---	632-875	798-1105
074	1	1.15	2	522-784	---	---
	2	2.3	2	---	632-875	798-1105

FACTORY INSTALLED OPTIONS/FIELD INSTALLED ACCESSORY AIR RESISTANCE - in. w.g.

Air Volume cfm	Wet Indoor Coil			Dehumidification Coil	Gas Heating		Economizer	Filters	
	036	048	060, 072, 074		Medium Heat	High Heat		MERV 8	MERV 13

036-048 MODELS

800	0.01	0.01	---	0.00	0.02	0.02	0.04	0.04	0.05
1000	0.02	0.02	---	0.00	0.02	0.02	0.04	0.04	0.07
1200	0.03	0.04	---	0.01	0.02	0.02	0.04	0.04	0.07
1400	0.04	0.05	---	0.02	0.02	0.03	0.04	0.04	0.07
1600	0.05	0.06	---	0.03	0.03	0.04	0.04	0.04	0.07
1800	0.06	0.07	---	0.04	0.04	0.05	0.05	0.04	0.07
2000	0.08	0.09	---	0.04	0.04	0.06	0.05	0.05	0.08

060, 072, 074 MODELS

1000	---	---	0.02	0.00	0.02	0.02	0.04	0.03	0.05
1200	---	---	0.04	0.00	0.02	0.02	0.04	0.03	0.07
1400	---	---	0.05	0.01	0.02	0.03	0.04	0.04	0.07
1600	---	---	0.07	0.02	0.03	0.04	0.04	0.04	0.07
1800	---	---	0.08	0.02	0.03	0.05	0.05	0.05	0.07
2000	---	---	0.10	0.03	0.04	0.06	0.05	0.05	0.07
2200	---	---	0.11	0.04	0.04	0.07	0.05	0.05	0.08
2400	---	---	0.13	0.04	0.05	0.08	0.05	0.05	0.08
2600	---	---	0.15	0.05	0.05	0.09	0.06	0.05	0.08
2800	---	---	0.16	0.05	0.06	0.10	0.06	0.05	0.08
3000	---	---	0.18	0.06	0.07	0.11	0.06	0.05	0.08

POWER EXHAUST FAN PERFORMANCE

Return Air System Static Pressure in. w.g.	Air Volume Exhausted cfm
0.00	2000
0.05	1990
0.10	1924
0.15	1810
0.20	1664
0.25	1507
0.30	1350
0.35	1210

BLOWER DATA

CEILING DIFFUSERS AIR RESISTANCE (in. w.g.)

Air Volume cfm	RTD9-65S Step-Down Diffuser			FD9-65S Flush Diffuser	RTD11-95S Step-Down Diffuser			FD11-95S Flush Diffuser
	2 Ends Open	1 Side & 2 Ends Open	All Ends & Sides Open		2 Ends Open	1 Side & 2 Ends Open	All Ends & Sides Open	
800	0.15	0.13	0.11	0.11	---	---	---	---
1000	0.19	0.16	0.14	0.14	---	---	---	---
1200	0.25	0.20	0.17	0.17	---	---	---	---
1400	0.33	0.26	0.20	0.20	---	---	---	---
1600	0.43	0.32	0.20	0.24	---	---	---	---
1800	0.56	0.40	0.30	0.30	0.13	0.11	0.09	0.09
2000	0.73	0.50	0.36	0.36	0.15	0.13	0.11	0.10
2200	0.95	0.63	0.44	0.44	0.18	0.15	0.12	0.12
2400	---	---	---	---	0.21	0.18	0.15	0.14
2600	---	---	---	---	0.24	0.21	0.18	0.17
2800	---	---	---	---	0.27	0.24	0.21	0.20
3000	---	---	---	---	0.32	0.29	0.25	0.25

CEILING DIFFUSER AIR THROW DATA

Air Volume - cfm	¹ Effective Throw - ft.	
Model No.	RTD9-65S	FD9-65S
800	10 - 17	14 - 18
1000	10 - 17	15 - 20
1200	11 - 18	16 - 22
1400	12 - 19	17 - 24
1600	12 - 20	18 - 25
1800	13 - 21	20 - 28
2000	14 - 23	21 - 29
2200	16 - 25	22 - 30
Model No.	RTD11-95S	FD11-95S
2600	24 - 29	19 - 24
2800	25 - 30	20 - 28
3000	27 - 33	21 - 29

¹ Effective throw based on terminal velocities of 75 ft. per minute.

ELECTRICAL DATA**3 TON****3 TON HIGH EFFICIENCY (R-410A)****LGH036H4**

¹ Voltage - 60hz		208/230V - 1 Ph	208/230V - 3 Ph	460V - 3 Ph	575V - 3 Ph
Compressor	Rated Load Amps	15.3	11.6	5.7	4
	Locked Rotor Amps	83	73	38	25.6
Outdoor Fan Motor	Full Load Amps	4.1	4.1	2.1	1.6
Power Exhaust (1) 0.33 HP	Full Load Amps	2.4	2.4	1.3	1
Service Outlet 115V GFI (amps)		15	15	15	20
Indoor Blower Motor	Horsepower	0.5	0.5	0.5	0.5
	Full Load Amps	4.3	4.3	2.2	1.7
² Maximum Overcurrent Protection	Unit Only	40	30	15	15
	With (1) 0.33 HP Power Exhaust	45	35	15	15
³ Minimum Circuit Ampacity	Unit Only	28	23	12	9
	With (1) 0.33 HP Power Exhaust	30	26	13	10

NOTE - All units have a minimum Short Circuit Current Rating (SCCR) of 5000 amps.

¹ Extremes of operating range are plus and minus 10% of line voltage.² HACR type breaker or fuse.³ Refer to National or Canadian Electrical Code manual to determine wire, fuse and disconnect size requirements.**3 TON STANDARD EFFICIENCY (R-410A)****LGH036S4**

¹ Voltage - 60hz		208/230V - 3 Ph		460V - 3 Ph		575V - 3 Ph	
Compressor	Rated Load Amps	11.6		5.7		4	
	Locked Rotor Amps	73		38		25.6	
Outdoor Fan Motor	Full Load Amps	0.9		0.6		0.5	
Power Exhaust (1) 0.33 HP	Full Load Amps	2.4		1.3		1	
Service Outlet 115V GFI (amps)		15		15		20	
Indoor Blower Motor	Horsepower	0.75	1	0.75	1	0.75	1
	Full Load Amps	3.5	4.6	1.6	2.1	1.3	1.7
² Maximum Overcurrent Protection	Unit Only	30	30	15	15	15	15
	With (1) 0.33 HP Power Exhaust	30	30	15	15	15	15
³ Minimum Circuit Ampacity	Unit Only	19	20	10	10	7	8
	With (1) 0.33 HP Power Exhaust	22	23	11	12	8	9

NOTE - All units have a minimum Short Circuit Current Rating (SCCR) of 5000 amps.

¹ Extremes of operating range are plus and minus 10% of line voltage.² HACR type breaker or fuse.³ Refer to National or Canadian Electrical Code manual to determine wire, fuse and disconnect size requirements.

ELECTRICAL DATA**4 TON****4 TON HIGH EFFICIENCY (R-410A)****LGHO48H4**

¹ Voltage - 60hz		208/230V - 1 Ph	208/230V - 3 Ph	460V - 3 Ph	575V - 3 Ph
Compressor	Rated Load Amps	21.2	14	6.4	4.6
	Locked Rotor Amps	104	83.1	41	33
Outdoor Fan Motor	Full Load Amps	4.1	4.1	2.1	1.6
Power Exhaust (1) 0.33 HP	Full Load Amps	2.4	2.4	1.3	1
Service Outlet 115V GFI (amps)		15	15	15	20
Indoor Blower Motor	Horsepower	0.75	0.75	0.75	0.75
	Full Load Amps	6.1	6.1	3.1	2.4
² Maximum Overcurrent Protection	Unit Only	50	40	15	15
	With (1) 0.33 HP Power Exhaust	60	40	20	15
³ Minimum Circuit Ampacity	Unit Only	37	28	14	10
	With (1) 0.33 HP Power Exhaust	40	31	15	11

NOTE - All units have a minimum Short Circuit Current Rating (SCCR) of 5000 amps.

¹ Extremes of operating range are plus and minus 10% of line voltage.² HACR type breaker or fuse.³ Refer to National or Canadian Electrical Code manual to determine wire, fuse and disconnect size requirements.**4 TON STANDARD EFFICIENCY (R-410A)****LGHO48S4**

¹ Voltage - 60hz		208/230V - 3 Ph		460V - 3 Ph		575V - 3 Ph	
Compressor	Rated Load Amps	14		6.4		4.6	
	Locked Rotor Amps	83.1		41		33	
Outdoor Fan Motor	Full Load Amps	1.7		1.1		0.7	
Power Exhaust (1) 0.33 HP	Full Load Amps	2.4		1.3		1	
Service Outlet 115V GFI (amps)		15		15		20	
Indoor Blower Motor	Horsepower	0.75	2	0.75	2	0.75	2
	Full Load Amps	3.5	7.5	1.6	3.4	1.3	2.7
² Maximum Overcurrent Protection	Unit Only	35	40	15	15	15	15
	With (1) 0.33 HP Power Exhaust	35	40	15	20	15	15
³ Minimum Circuit Ampacity	Unit Only	23	27	11	13	8	10
	With (1) 0.33 HP Power Exhaust	26	30	12	14	9	11

NOTE - All units have a minimum Short Circuit Current Rating (SCCR) of 5000 amps.

¹ Extremes of operating range are plus and minus 10% of line voltage.² HACR type breaker or fuse.³ Refer to National or Canadian Electrical Code manual to determine wire, fuse and disconnect size requirements.

ELECTRICAL DATA**5 TON****5 TON HIGH EFFICIENCY (R-410A)****LGH060H4**

¹ Voltage - 60hz		208/230V - 1 Ph	208/230V - 3 Ph	460V - 3 Ph	575V - 3 Ph
Compressor	Rated Load Amps	27.1	16.5	7.2	5.5
	Locked Rotor Amps	152.9	110	52	38.9
Outdoor Fan Motor	Full Load Amps	4.1	4.1	2.1	1.6
Power Exhaust (1) 0.33 HP	Full Load Amps	2.4	2.4	1.3	1
Service Outlet 115V GFI (amps)		15	15	15	20
Indoor Blower Motor	Horsepower	1	1	1	1
	Full Load Amps	7.4	7.4	3.7	3
² Maximum Overcurrent Protection	Unit Only	70	45	20	15
	With (1) 0.33 HP Power Exhaust	70	50	20	15
³ Minimum Circuit Ampacity	Unit Only	46	33	15	12
	With (1) 0.33 HP Power Exhaust	48	35	17	13

NOTE - All units have a minimum Short Circuit Current Rating (SCCR) of 5000 amps.

¹ Extremes of operating range are plus and minus 10% of line voltage.² HACR type breaker or fuse.³ Refer to National or Canadian Electrical Code manual to determine wire, fuse and disconnect size requirements.**5 TON STANDARD EFFICIENCY (R-410A)****LGH060S4**

¹ Voltage - 60hz		208/230V - 3 Ph		460V - 3 Ph		575V - 3 Ph	
Compressor	Rated Load Amps	16.5		7.2		5.5	
	Locked Rotor Amps	110		52		38.9	
Outdoor Fan Motor	Full Load Amps	2.4		1.3		1	
Power Exhaust (1) 0.33 HP	Full Load Amps	2.4		1.3		1	
Service Outlet 115V GFI (amps)		15		15		20	
Indoor Blower Motor	Horsepower	1	2	1	2	1	2
	Full Load Amps	4.6	7.5	2.1	3.4	1.7	2.7
² Maximum Overcurrent Protection	Unit Only	40	45	15	20	15	15
	With (1) 0.33 HP Power Exhaust	45	45	20	20	15	15
³ Minimum Circuit Ampacity	Unit Only	28	31	13	14	10	11
	With (1) 0.33 HP Power Exhaust	31	33	14	16	11	12

NOTE - All units have a minimum Short Circuit Current Rating (SCCR) of 5000 amps.

¹ Extremes of operating range are plus and minus 10% of line voltage.² HACR type breaker or fuse.³ Refer to National or Canadian Electrical Code manual to determine wire, fuse and disconnect size requirements.

ELECTRICAL DATA**6 TON****6 TON HIGH EFFICIENCY (R-410A)****LGH072H4**

¹ Voltage - 60hz		208/230V - 3 Ph		460V - 3 Ph		575V - 3 Ph	
Compressor	Rated Load Amps	19.6		8.2		6.6	
	Locked Rotor Amps	136		66.1		55.3	
Outdoor Fan Motor	Full Load Amps	2.4		1.3		1	
Power Exhaust (1) 0.33 HP	Full Load Amps	2.4		1.3		1	
Service Outlet 115V GFI (amps)		15		15		20	
Indoor Blower Motor	Horsepower	1	2	1	2	1	2
	Full Load Amps	4.6	7.5	2.1	3.4	1.7	2.7
² Maximum Overcurrent Protection	Unit Only	50	50	20	20	15	15
	With (1) 0.33 HP Power Exhaust	50	50	20	20	15	15
³ Minimum Circuit Ampacity	Unit Only	32	35	14	15	11	12
	With (1) 0.33 HP Power Exhaust	34	37	15	17	12	13

NOTE - All units have a minimum Short Circuit Current Rating (SCCR) of 5000 amps.

¹ Extremes of operating range are plus and minus 10% of line voltage.² HACR type breaker or fuse.³ Refer to National or Canadian Electrical Code manual to determine wire, fuse and disconnect size requirements.**ELECTRICAL DATA****6 TON****6 TON HIGH EFFICIENCY (R-410A)****LGH074H4**

¹ Voltage - 60hz		208/230V - 3 Ph		460V - 3 Ph		575V - 3 Ph	
Compressor	Rated Load Amps	17.6		8.5		6.3	
	Locked Rotor Amps	136		66.1		55.3	
Outdoor Fan Motor	Full Load Amps	2.4		1.3		1	
Power Exhaust (1) 0.33 HP	Full Load Amps	2.4		1.3		1	
Service Outlet 115V GFI (amps)		15		15		20	
Indoor Blower Motor	Horsepower	1	2	1	2	1	2
	Full Load Amps	7.4	7.5	3.7	3.4	3	2.7
² Maximum Overcurrent Protection	Unit Only	45	45	20	20	15	15
	With (1) 0.33 HP Power Exhaust	50	50	25	25	15	15
³ Minimum Circuit Ampacity	Unit Only	32	32	16	16	12	12
	With (1) 0.33 HP Power Exhaust	35	35	17	17	13	13

NOTE - All units have a minimum Short Circuit Current Rating (SCCR) of 5000 amps.

¹ Extremes of operating range are plus and minus 10% of line voltage.² HACR type breaker or fuse.³ Refer to National or Canadian Electrical Code manual to determine wire, fuse and disconnect size requirements.

THIS PAGE INTENTIONALLY LEFT BLANK

THIS PAGE INTENTIONALLY LEFT BLANK

OUTDOOR SOUND DATA

1 Unit Model No.	Octave Band Linear Sound Power Levels dB, re 10 ⁻¹² Watts Center Frequency - Hz							1 Sound Rating Number (SRN) dBA
	125	250	500	1000	2000	4000	8000	
036, 048	63	66	70	71	68	62	53	75
060, 072, 074	67	72	77	76	73	68	61	82

NOTE - The octave sound power data does not include tonal corrections.

¹ Sound Rating Number according to ARI Standard 270-95 (includes pure tone penalty). "SRN" is the overall A-Weighted Sound Power Level, (Lwa), dB (100 Hz to 10,000 Hz).

WEIGHT DATA

Model Number	Outdoor Coil	Net		Shipping		Outdoor Coil	Net		Shipping	
		lbs.	kg	lbs.	kg		lbs.	kg	lbs.	kg
036 Base Unit	Eco-Last™	549	249	610	277	Fin/Tube	568	257	629	285
036 Max. Unit	Eco-Last™	743	337	804	365	Fin/Tube	762	346	823	373
048 Base Unit	Eco-Last™	565	256	626	284	Fin/Tube	598	271	659	299
048 Max. Unit	Eco-Last™	754	342	834	378	Fin/Tube	806	366	867	393
060 Base Unit	Eco-Last™	643	292	704	319	Fin/Tube	685	311	746	338
060 Max. Unit	Eco-Last™	871	395	932	423	Fin/Tube	913	414	974	442
072 Base Unit	Eco-Last™	720	327	781	354	Fin/Tube	762	346	823	373
072 Max. Unit	Eco-Last™	918	416	979	444	Fin/Tube	960	436	1021	463
074 Base Unit	Eco-Last™	720	327	781	354	Fin/Tube	762	346	823	373
074 Max. Unit	Eco-Last™	918	416	979	444	Fin/Tube	960	436	1021	463

OPTIONS / ACCESSORIES

		Shipping Weight	
		lbs.	kg.
ECONOMIZER / OUTDOOR AIR / EXHAUST			
Economizer			
Economizer, Includes Outdoor Air Hood and Barometric Relief Dampers with Hood		131	59
Outdoor Air Dampers			
Motorized		40	18
Manual		30	14
Power Exhaust			
Standard Static		35	17
GAS HEAT			
Medium Heat (adder over standard heat)		8	4
High Heat (adder over standard heat)		19	9
PACKAGING			
LTL Packaging (less than truck load)		60	27
ROOF CURBS			
Hybrid Roof Curbs, Downflow			
8 in. height	C1CURB70A-1	50	23
14 in. height	C1CURB71A-1	70	32
18 in. height	C1CURB72A-1	80	36
24 in. height	C1CURB73A-1	100	45
Adjustable Pitch Curb, Downflow			
14 in. height		113	51
CEILING DIFFUSERS			
Step-Down	RTD9-65S	80	36
	RTD11-95S	118	54
Flush	FD9-65S	80	36
	FD11-95S	118	54
Transitions	T1TRAN10AN1	22	10
	T1TRAN20N-1	21	10
DEHUMIDIFICATION SYSTEM			
Dehumidification Option (Net Weight)		27	12

UNIT CLEARANCES - INCHES (MM)

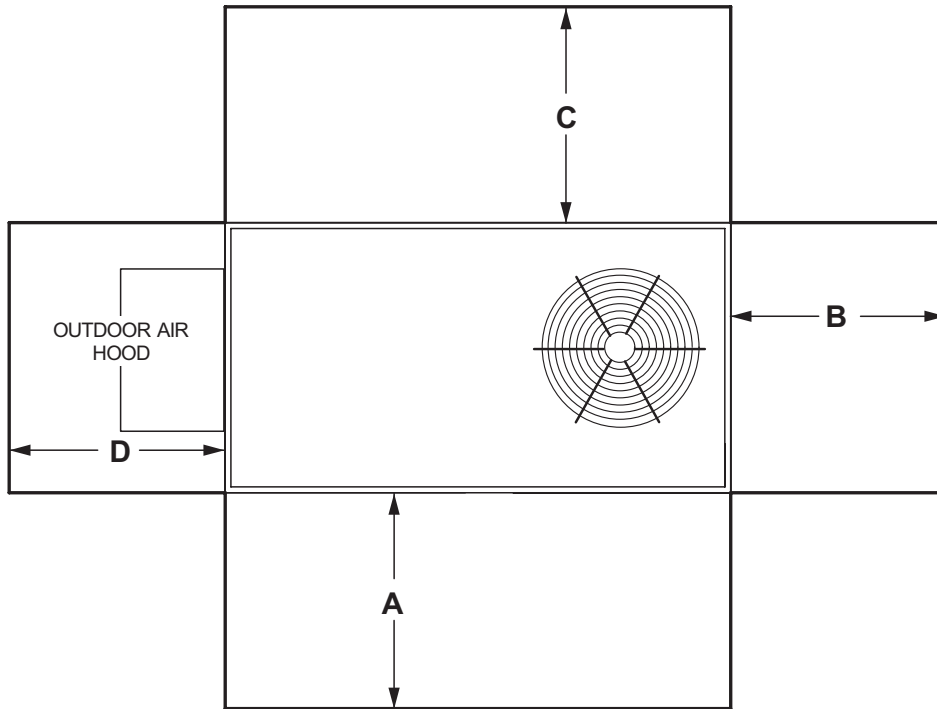

¹ Unit Clearance	A		B		C		D		Top Clearance
	in.	mm	in.	mm	in.	mm	in.	mm	
Service Clearance	48	1219	36	914	36	934	36	914	Unobstructed
Clearance to Combustibles	36	914	1	25	1	25	1	25	
Minimum Operation Clearance	36	914	36	914	36	914	36	914	

NOTE - Entire perimeter of unit base requires support when elevated above the mounting surface.

¹ **Service Clearance** - Required for removal of serviceable parts.

Clearance to Combustibles - Required clearance to combustible material.

Minimum Operation Clearance - Required clearance for proper unit operation.

DIMENSIONS - UNIT - INCHES (MM)

Model No.	CORNER WEIGHTS								CENTER OF GRAVITY			
	AA		BB		CC		DD		EE		FF	
	lbs.	kg	lbs.	kg	lbs.	kg	lbs.	kg	in.	mm	in.	mm
LGH036 Base Unit	98	45	119	54	192	87	158	72	38.5	978	18	457
LGH036 Max. Unit	137	62	155	70	250	113	221	100	40	1016	18	457
LGH048 Base Unit	104	47	126	57	202	92	167	76	38.5	978	18	457
LGH048 Max. Unit	145	66	164	74	264	120	233	106	40	1016	18	457
LGH060 Base Unit	118	54	144	65	232	105	191	87	38.5	978	18	457
LGH060 Max. Unit	164	75	186	84	299	136	264	120	40	1016	18	457
LGH072 Base Unit	132	60	160	73	258	117	212	96	38.5	978	18	457
LGH072 Max. Unit	173	78	195	89	314	143	278	126	40	1016	18	457
LGH074 Base Unit	132	60	160	73	258	117	212	96	38.5	978	18	457
LGH074 Max. Unit	173	78	195	89	314	143	278	126	40	1016	18	457

Base Unit - The unit with NO INTERNAL OPTIONS.

Max. Unit - The unit with ALL INTERNAL OPTIONS Installed. (Economizer, Standard Static Power Exhaust Fans, Controls, etc.). Does not include accessories external to unit or high static power exhaust.

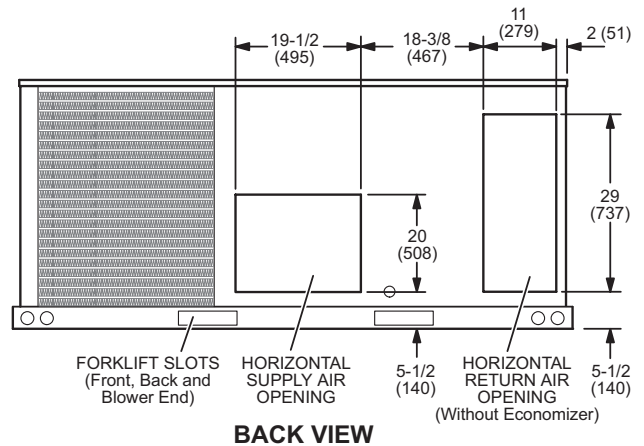
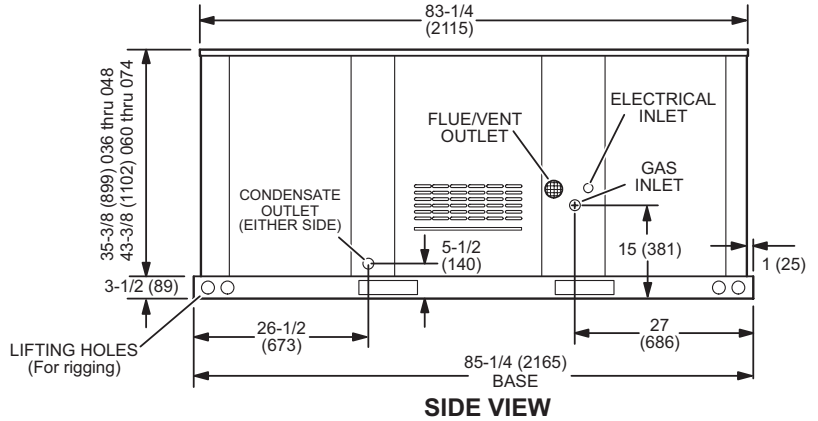
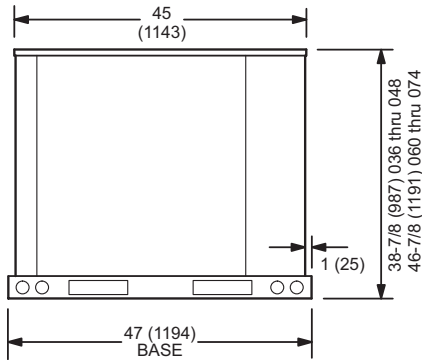
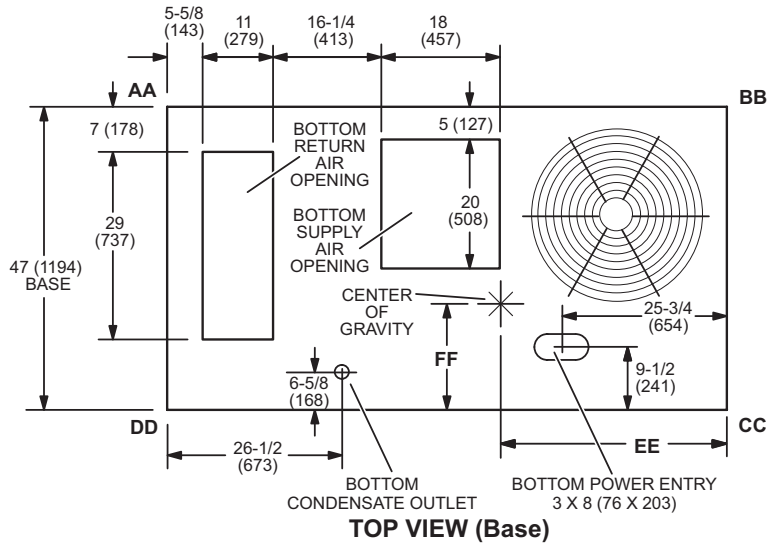

DIMENSIONS - ACCESSORIES - INCHES (MM)

OUTDOOR AIR HOOD DETAIL FOR OPTIONAL ECONOMIZER AND BAROMETRIC RELIEF DAMPERS (Downflow Applications)

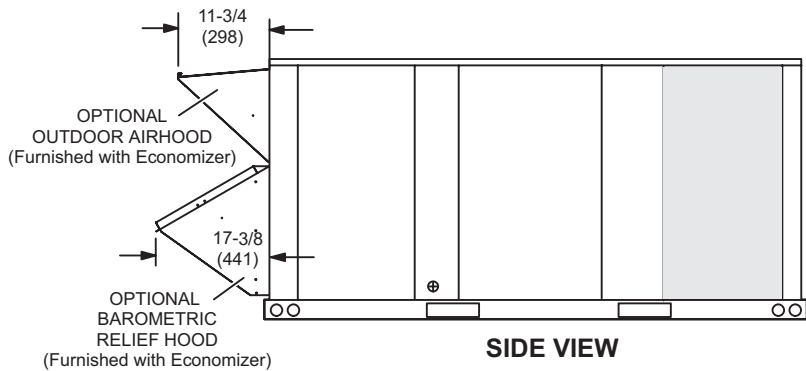

OUTDOOR AIR HOOD FOR ECONOMIZER (Furnished)

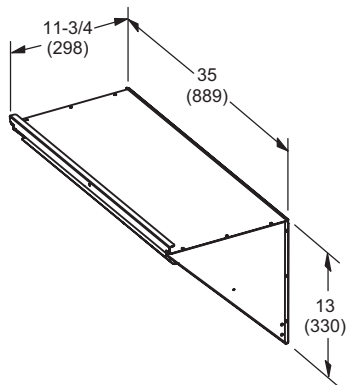

BAROMETRIC RELIEF HOOD FOR ECONOMIZER (Furnished)

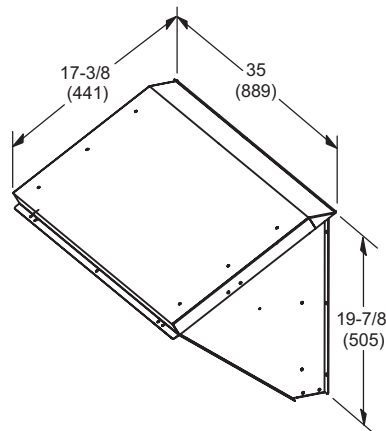

OUTDOOR AIR DAMPER HOOD DETAIL (Downflow or Horizontal Applications)

MANUAL OUTDOOR AIR HOOD

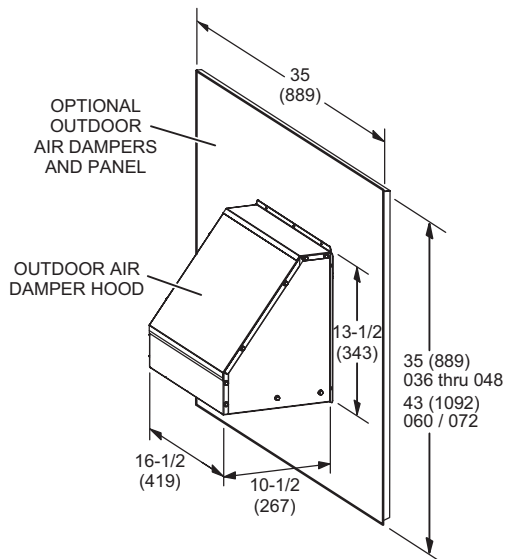
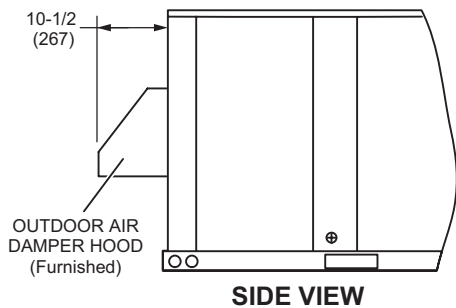

MOTORIZED OUTDOOR AIR HOOD

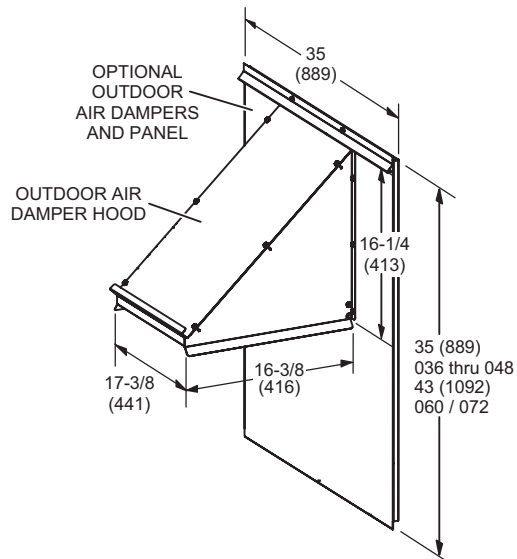
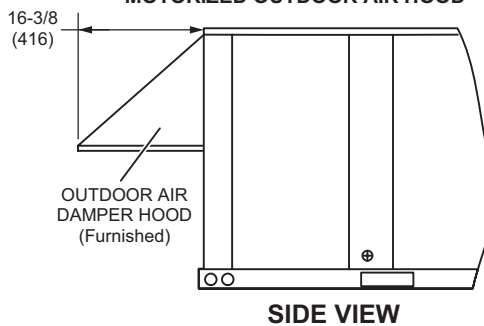

DIMENSIONS - ACCESSORIES - INCHES (MM)

OUTDOOR AIR HOOD DETAIL WITH OPTIONAL ECONOMIZER AND BAROMETRIC RELIEF DAMPERS (Horizontal Applications)

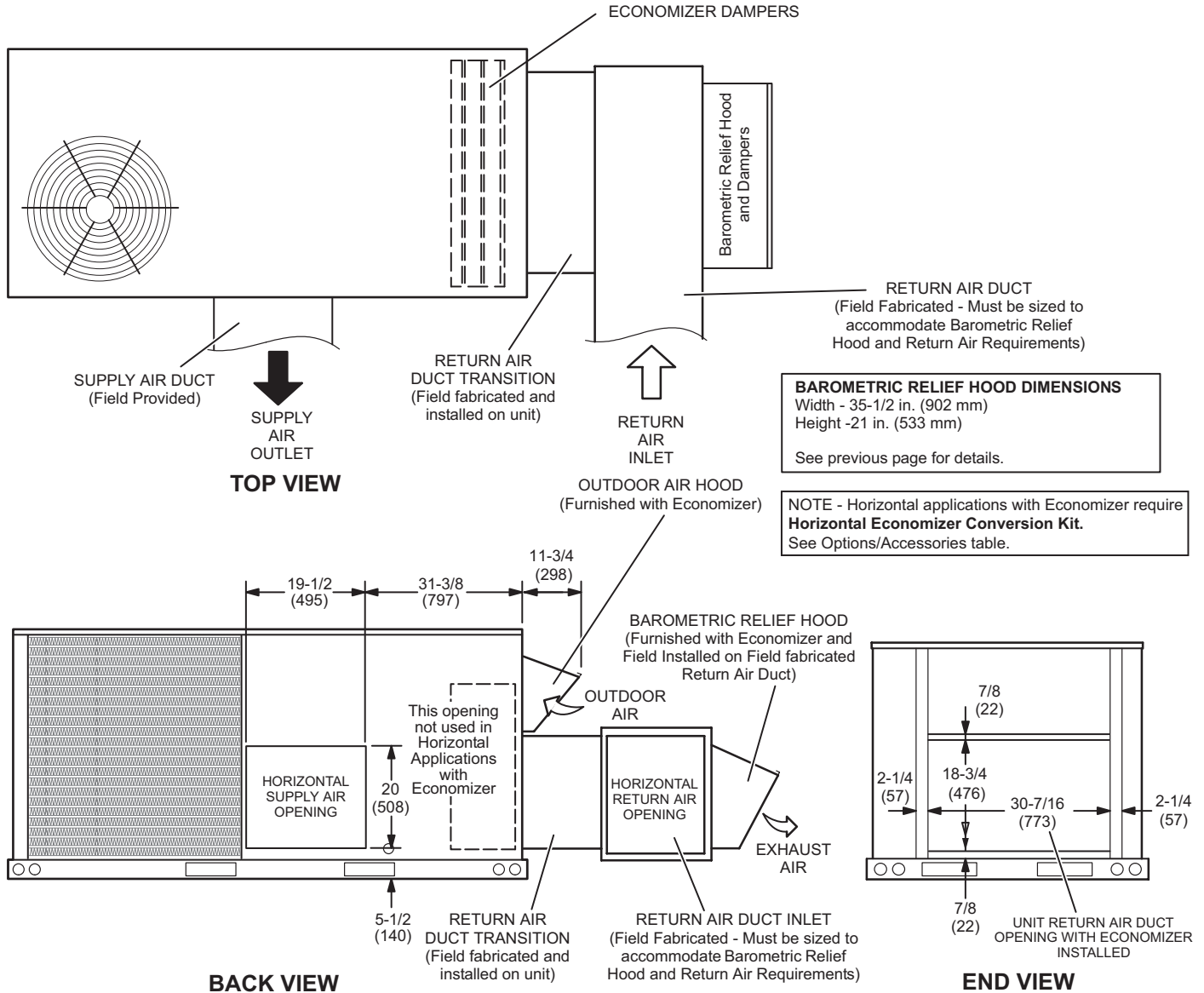

NOTE - Return Air Duct and Transition must be supported.

HYBRID ROOF CURBS - DOUBLE DUCT OPENING

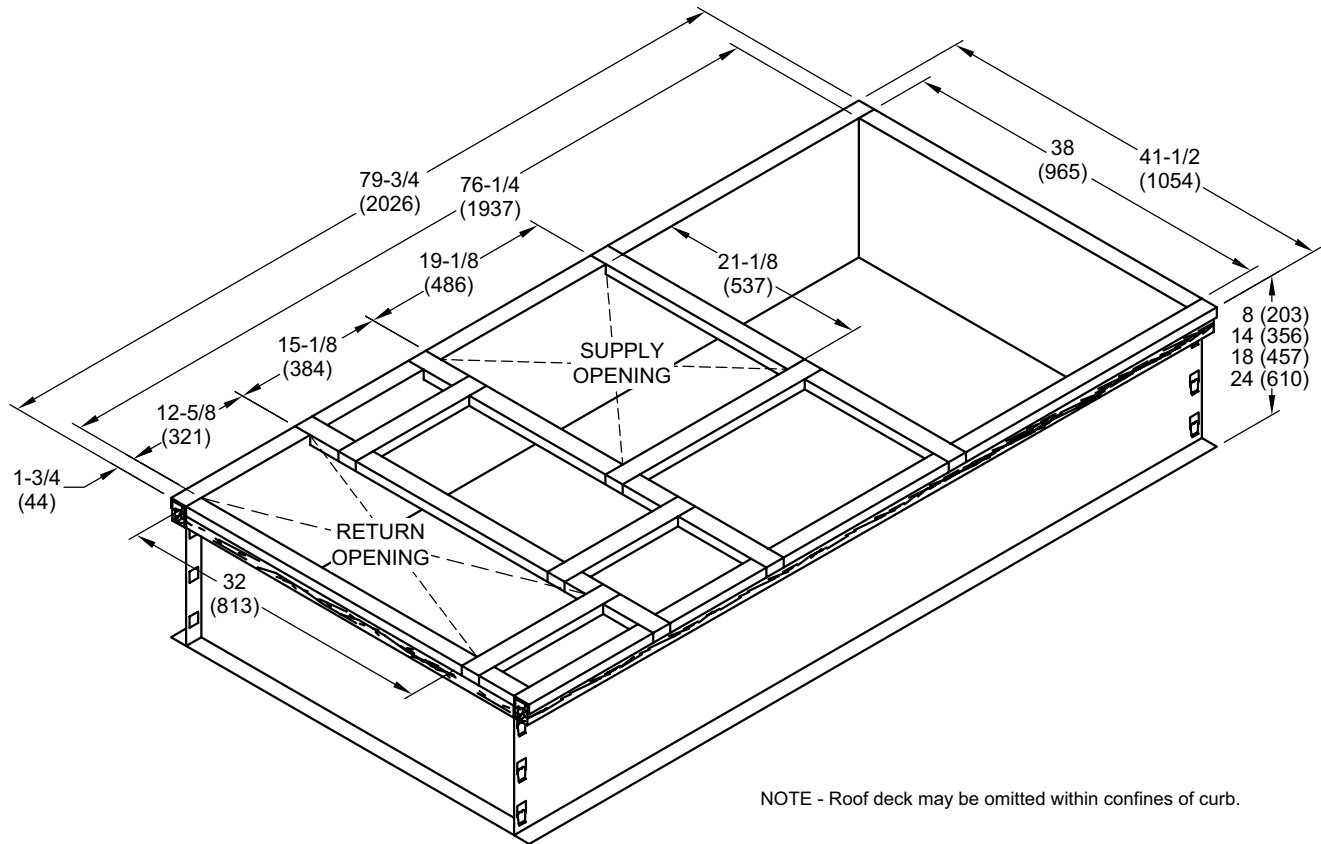

TYPICAL FLASHING DETAIL FOR ROOF CURB

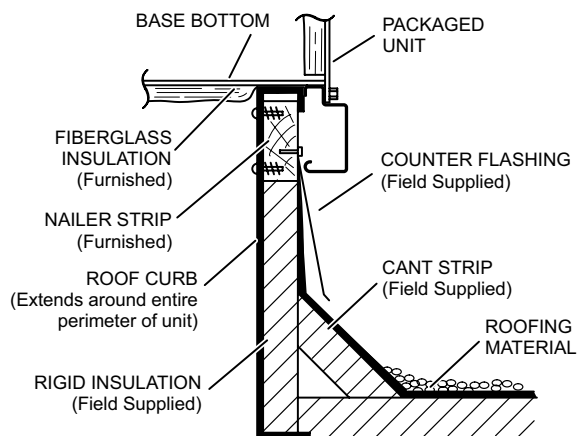

DETAIL ROOF CURB

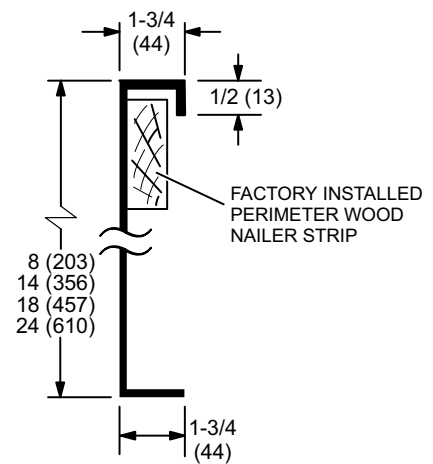

DIMENSIONS - ACCESSORIES - INCHES (MM)

ADJUSTABLE PITCH CURBS - DOUBLE DUCT OPENING

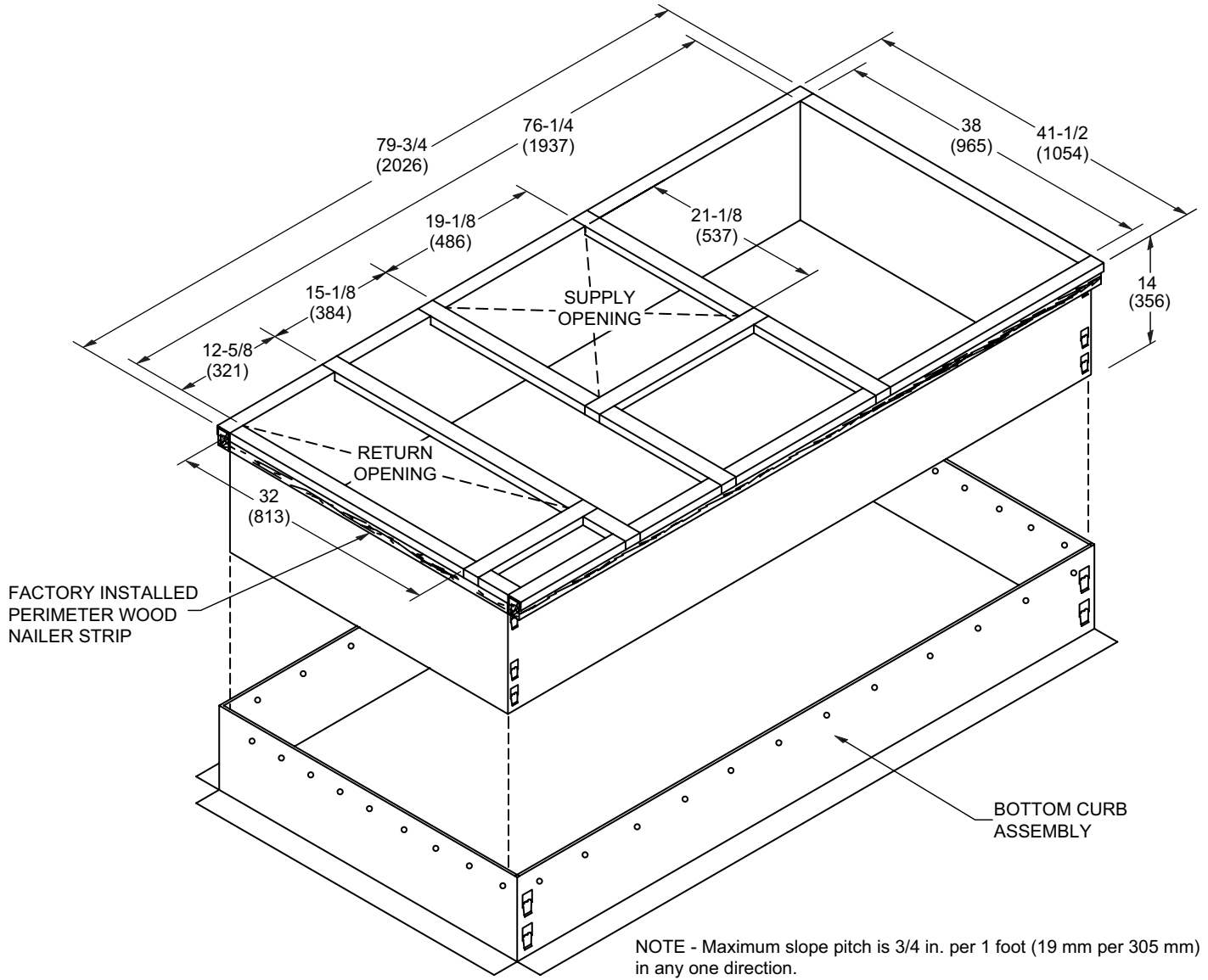

TYPICAL FLASHING DETAIL FOR ROOF CURB

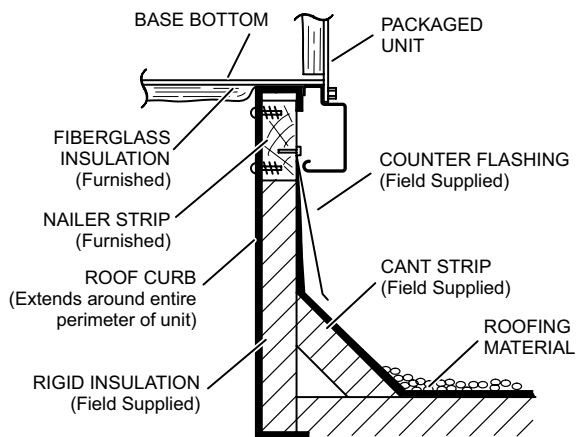

DETAIL ROOF CURB

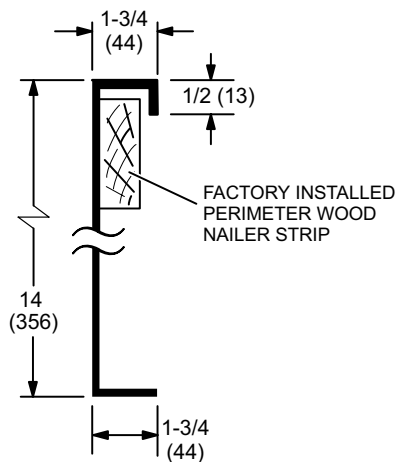

TRANSITIONS

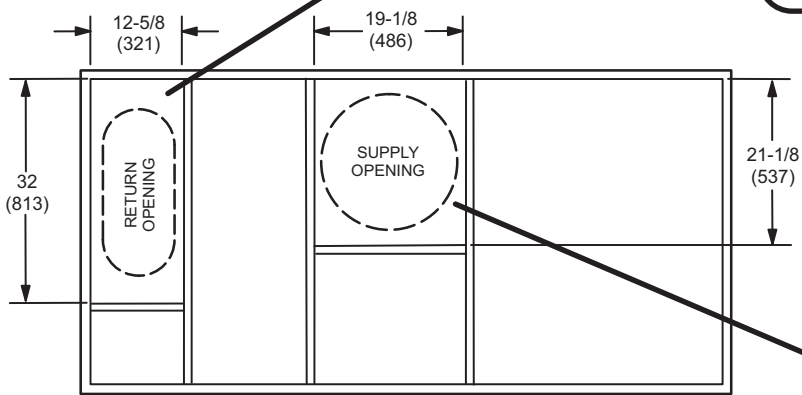
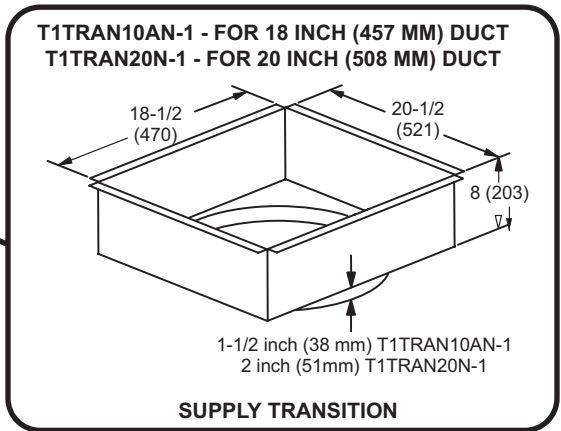
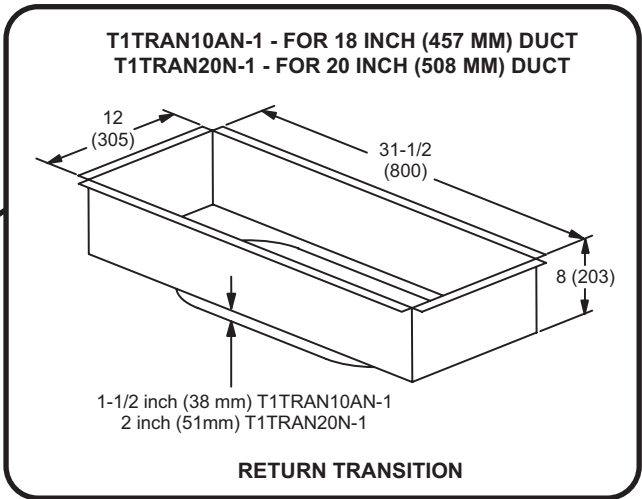

DIMENSIONS - ACCESSORIES - INCHES (MM)

COMBINATION CEILING SUPPLY AND RETURN DIFFUSERS

STEP-DOWN CEILING DIFFUSER

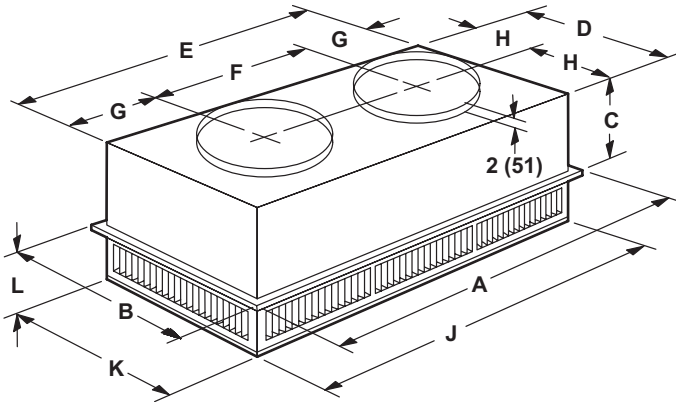

FLUSH CEILING DIFFUSER

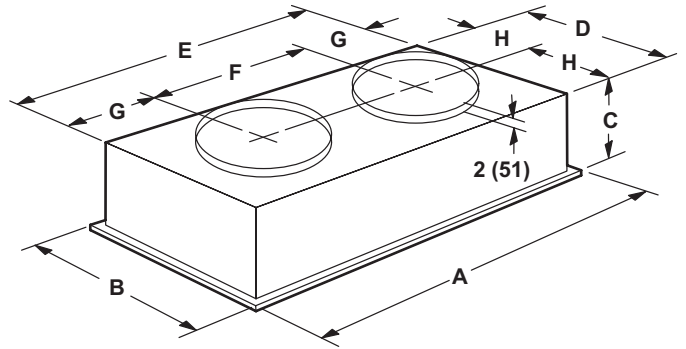

Model Number		RTD9-65S	RTD11-95S
A	in.	47-5/8	47-5/8
	mm	1159	1159
B	in.	23-5/8	29-5/8
	mm	600	752
C	in.	11-3/8	14-3/8
	mm	289	365
D	in.	21-1/2	27-1/2
	mm	546	699
E	in.	45-1/2	45-1/2
	mm	1156	1158
F	in.	22-1/2	22-1/2
	mm	572	572
G	in.	11-1/2	11-1/2
	mm	292	292
H	in.	10-3/4	13-3/4
	mm	273	349
J	in.	45-1/2	45-1/2
	mm	1156	1156
K	in.	21-1/2	27-1/2
	mm	546	699
L	in.	7-1/8	8-1/8
	mm	181	206
Duct Size	in.	18 round	20 round
	mm	457 round	508 round

Model Number		FD9-65S	FD11-95S
A	in.	47-5/8	47-5/8
	mm	1159	1159
B	in.	23-5/8	29-5/8
	mm	600	752
C	in.	13-1/2	16-5/8
	mm	343	422
D	in.	21	27
	mm	533	686
E	in.	45	45
	mm	1143	1143
F	in.	22-1/2	22-1/2
	mm	572	572
G	in.	11-1/4	11-1/4
	mm	286	286
H	in.	10-1/2	13-1/2
	mm	267	343
Duct Size	in.	18 round	20 round
	mm	457 round	508 round

REVISIONS

Section	Description
Dehumidification System Rating Tables	Updated for all models.
Dimensions - Accessories	Updated dimension drawing for Motorized Outdoor Air Damper Hood.
Features and Benefits	Eco-Last™ equipped models can now be used with Dehumidification System.



HRAI
✓ MEMBER COMPANY



Intertek

ALLIED™
Commercial

Visit us at www.allied-commercial.com

For the latest technical information, visit us at www.allied-commercial.com

Contact us at 1-800-448-5872

NOTE - Due to Allied Commercial ongoing commitment to quality, Specifications, Ratings and Dimensions subject to change without notice and without incurring liability. Improper installation, adjustment, alteration, service or maintenance can cause property damage or personal injury. Installation and service must be performed by a qualified installer and servicing agency.