

TECHNICAL GUIDE

DOWNFLOW/UPFLOW ELECTRIC FURNACE

MODELS: EB/EU SERIES



EB



EU

DESCRIPTION

The EB/EU Series Electric Furnace is actually two systems in one. As an air handler, it provides airflow for air conditioning and heat pump cooling requirements. As an electric furnace, its range of heating capacities makes the EB/EU a perfect match for the heating requirements of almost any manufactured or modular home.

WARRANTY

2-year limited parts warranty, and 1-year labor.

FEATURES

- Zero clearance feature allows the EB/EU to be installed where space is a premium.
- Pre-painted white front panels provide a scratch resistant, attractive, easy to clean appliance finish.
- Built-in coil cabinet is design-matched to work in conjunction with heat pumps and air conditioners manufactured by Johnson Controls, Inc. in Wichita, Kansas (which provide ease of installation and highly efficient operating performance). Downflow or upflow coil shelf accessory is required for the EB model. The EU model has an upflow coil shelf already installed, and the unit has a solid door on it.
- Air Conditioner and Heat Pump operation ready, all models have a multi-speed blower capable of handling cooling and heat pump loads.
- Heating package includes specifically designed, long lasting nickel/chrome heat elements.
- Universal throw-away filter cleans the air, and is easy to replace.
- Accessory blower kit available for larger A/C and HP applications.
- As defined by the U.S. Department of Energy, these furnaces are 100% efficient when used in specified applications.



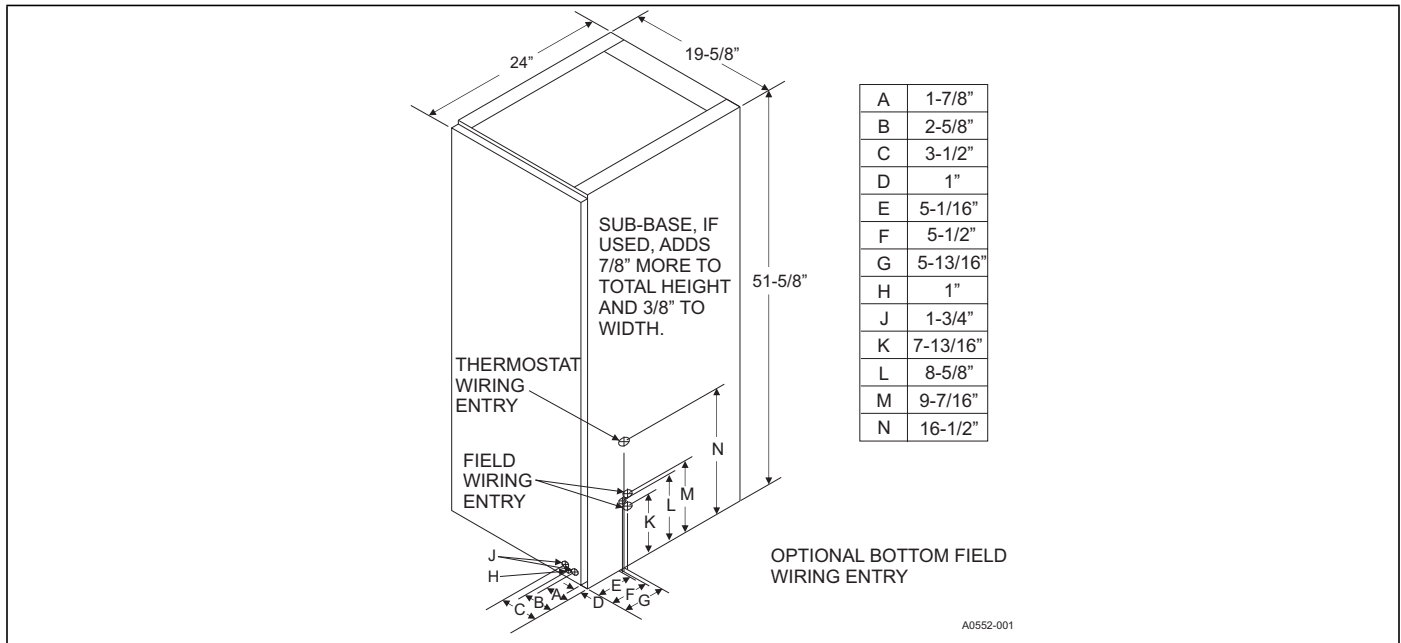

A0552-001

Physical and Electrical Data

¹ MODEL NUMBER			^{2,3} EB10F EU10A	^{3,4} EB12F EU12A	⁵ EB15F EU15A	⁵ EB17F EU17A	⁵ EB20F EU20A	⁵ EB23F EU23A
D.O.E. Output	240 VAC	BTU	34,000	39,000	51,000	56,000	67,000	77,000
	60 Hz., 1 Phase	kW	10.0	11.4	15.0	16.4	19.6	22.6
OUTPUT CAPACITY	230 VAC	BTU	31,000	36,000	47,000	52,000	61,000	71,000
	60 Hz., 1 Phase	kW	9.1	10.6	13.8	15.2	17.9	20.8
	220 VAC	BTU	29,000	33,000	43,000	48,000	57,000	65,000
	60 Hz., 1 Phase	kW	8.5	9.7	12.6	14.1	16.7	19.1
Element Capacity @ 240 VAC		kW	9.6	11.2	14.4	16.0	19.2	21.6
		Amps	40.0	46.7	60.0	66.7	80.0	90.0
Motor Amps @ 240 V.			4.0 Maximum					
Circuit Load Amps @ 240 V.	CKT 1		44.0	50.7 ⁵	44.0	47.3	44.0	47.3
	CKT 2		NA	NA	20.0	23.4	40.0	46.7
Filter Size			16 x 20 x 1					
Shipping Weights			83	84	85	86	84	86

NOTES:

- 1 Casing or Cabinet must be permanently grounded in accordance with N.E.C. or other applicable codes.
- 2 Does Not require a Jumper.
- 3 Approved for Single Branch Circuit Service Only.
- 4 Jumper provided fro Single Branch Circuit Only.
- 5 Requires Jumper Bars (P/N 3500-378P).

EB/EU Series Blower Performance

Static Pressure (Inches of WC)		.0	.1	.2	.3	.4	.5	.6	.7	.8
Low Speed Heating Speed Models EB10, 12, 15	CFM (STD. Air)	945	936	936	924	915	889	870	813	705
Medium Speed Heating Speed Models EB17, 20, 23	CFM (STD. Air)	1160	1145	1145	1140	1129	1109	1073	1027	935
Medium High with A-Coil in place	CFM (STD. Air)	1340	1317	1290	1252	1208	1158	1095	1021	876
High with A-Coil in place	CFM (STD. Air)	1573	1534	1490	1435	1369	1309	1237	1135	1019

Wiring Requirements

MODELS	¹ EB10F EU10A	² EB12F EU12A	³ EB15F EU15A		³ EB17F EU17A		³ EB20F EU20A		³ EB23F EU23A	
Single Branch Circuit Service	2 Leads + 1 Ground CKT #1									
Nominal Circuit Load - AMPS	44.0	50.7	64.0		70.7		84.0		94.0	
Minimum Wire Size (90°C)	#8	#6	#4		#4		#3		#2	
Minimum Wire Size (75°C)	#6	#6	#4		#3		#2		#1	
Minimum Wire Size (60°C)	#6	#4	#3		#2		#1		#0	
Ground Wire Size	#10	#8	#8		#8		#6		#6	
Max. Fuse (or C.B.) - AMPS	60	70	80		90		110		125	
Dual Branch Circuit Service	NOT APPROVED		CKT #1	CKT #2	CKT #1	CKT #2	CKT #1	CKT #2	CKT #1	CKT #2
Branch Circuit Load - Amps			44.0	20.1	47.3	23.4	44.0	40.0	47.3	46.7
Branch Circuit Min. - Amps			55.0	25.2	59.2	29.3	55.0	50.0	59.2	58.4
Minimum Wire Size (90°C)			#8	#10	#6	#10	#8	#8	#6	#6
Minimum Wire Size (75°C)			#6	#10	#6	#10	#6	#8	#6	#6
Minimum Wire Size (60°C)			#6	#10	#4	#10	#6	#6	#4	#4
Ground Wire Size ⁴			#10	#10	#10	#10	#10	#10	#10	#10
Max. Fuse (or C.B.) - Amps			60	30	60	30	60	50	60	60

NOTES:

- Does Not require a Jumper.
- Jumper provided for Single Branch Circuit Only.
- Requires Jumper Bars (P/N 3500-378P).
- Refer to National Electrical Code (NEC). Table 250-122 for Non-Sheathed Conductor Ground Wire.

LOCATION

Access for servicing is an important factor in the location of any furnace. A minimum of 24 inches should be provided in front of the furnace for access to the heating elements and controls. This access may be provided by a closet door or by locating the furnace 24 inches from a facing wall or partition.

FURNACE CLEARANCE

This furnace is approved for zero (0) inch clearance to combustible material on all or any part of the furnace exterior and the inlet or outlet duct work except as stated below.

For furnaces installed in upflow application, there must be a minimum of 1" (2.54 cm) clearance from the bare surface of the outlet duct work for a distance of 3 feet (91.4 cm) from the supply air opening. This requirement is met if the duct is wrapped with an insulating material at least 1" thick and having an R-value of at least R-4.

RETURN AIR

In order for the furnace to work properly, a closet or alcove must have a certain total free area opening for return air.

For Heating Only Furnace

Minimum 200 sq. in (1290 sq. cm) free area opening. Use any return Grille with minimum 200 sq. in free opening.

For up to 4 Ton AC and 3.5 Ton HP Applications (Standard Blower)

Minimum 250 sq. in (1613 sq. cm) free area opening. The standard blower assembly supplied with the furnace is capable of handling up to 4 Ton AC and 3.5 Ton HP applications. Use any return grille with minimum 250 sq. in (1613 sq. cm) free area opening.

For 5 Ton AC and 4 Ton HP Applications (Accessory Blower)

Minimum 350 sq. in (2129 sq. cm) free area opening. Use 5 Ton AC/4 Ton HP blower accessory 3500-7901/A. Use accessory louvered door 3501-9311 or any return grille with a minimum 350 sq. in (2129 sq. cm) free area opening.

For downflow applications, the return air opening can be located in a closet front door, or in a sidewall above the furnace casing, or in a louvered door on the furnace. If opening for the return air is located in the floor, side walls or closet door anywhere below furnace casing height, 6 inches minimum clearance must be provided on the furnace side where return is located to provide for proper air flow.

For Upflow installations, a closet that is 32 inches wide by 30 inches deep with a 30-inch wide door is necessary. This is not required if there is a return grille installed below furnace.

AIR FILTER

The filter supplied with the furnace is of the throw-away type. Filters need to be cleaned frequently. Shake out all loose dirt, and use vacuum cleaner to clean additionally. This method of cleaning prolongs the life of filters. DO change filters often since clean filters not only provide added comfort, better and cleaner environment, but increase the efficiency of the furnace as well.

Filter Location

The furnace's front panel must be removed to gain access to the filter of the downflow furnace. (See Figure 2.) However, the filter for the upflow furnace* is located behind the return air grill, adjacent to the furnace closet or any other location in the return air.

