

**F80CTL (Series B)
80% AFUE, Two-Stage
Variable Speed, 4-Way Multipoise, Gas Furnace**

TEMPSTAR®
Heating and Cooling Products

Product Data



**SYST0101CW
Recommended
(sold separately)**



A200434

! WARNING

This furnace is not designed for use in mobile homes, trailers, or recreational vehicles. Such use could result in property damage and/or death.



Use of the AHRI Certified TM Mark indicates a manufacturer's participation in the program. For verification of certification for individual products, go to www.ahridirectory.org.



ISO 9001
Quality

A200115

EASIER TO SELL

- 80% AFUE
- Cabinet air leakage less than 2.0% at 1.0 in. w.c. and cabinet air leakage less than 1.4% at 0.5 in. w.c. when tested in accordance with ASHRAE standard 193
- Supports two-stage cooling units
- ION™ Communicating Control System
- Flame roll-out sensors standard
- Category I venting
- Blocked vent switch
- Dehumidification feature in cooling
- 24 VAC humidifier terminal
- Electronic air cleaner terminal
- All units can be installed in air quality management districts with a 40 ng/J NOx emissions requirements

TOUGHER

- Variable speed ECM blower motor
- Adjustable heating blower OFF delay
- Factory set blower ON delay
- RPJ aluminized steel heat exchanger
- High temperature limit control prevents overheating
- Direct ignition with Silicon Nitride ignitor
- One piece pre-painted steel cabinet
- On-board NFC antenna makes setup a tap away when using the Service Technician App.
- 3-digit display shows fault codes and furnace status
- RAT and SAT thermistors can provide temperature rise
- Two-stage induced draft blower
- In-shot burners
- Insulated blower compartment

EASIER TO INSTALL AND SERVICE

- 33-1/3" (847mm) high, for ease of installation
- Quarter turn knobs for easy door removal and secure attachment
- Convertible to propane gas conversion accessory kit
- Four position - upflow/downflow/horizontal (left/right) installation
- Three position vent elbow capability
- Through the casing flue pipe for counterflow applications
- Common venting with other Category I appliances
- Masonry chimney adapter available
- Self diagnostics
- Slide out blower assembly

LIMITED WARRANTY*

- 10 year No Hassle Replacement™ limited warranty
 - Lifetime heat exchanger limited warranty with timely registration
 - 5 year parts limited warranty
 - additional 5 year parts limited warranty with timely registration
- * For residential applications only, See warranty certificate for complete details and restrictions, including warranty coverage of other applications.

SPECIFICATIONS

UNIT SIZE		0451712	0701412	0701716	0702120	0901716	0902120	1102120	1352422	
HEATING AND CAPACITY AND EFFICIENCY										
Input BTUh *	All Standard, Low NOx Upflow	High	44,000	66,000	66,000	66,000	88,000	88,000	110,000	132,000
		Low	29,000	43,500	43,500	43,500	58,000	58,000	72,500	87,000
	Low Nox Downflow/Horizontal	High	42,000	63,000	63,000	63,000	84,000	84,000	105,000	126,000
		Low	29,000	43,500	43,500	43,500	58,000	58,000	72,500	87,000
Output Capacity (BTUh) [†]	All Standard, Low NOx Upflow	High	35,000	54,000	53,000	53,000	71,000	71,000	89,000	107,000
		Low	23,000	35,000	35,000	35,000	47,000	47,000	59,000	70,000
	Low Nox Downflow/Horizontal	High	34,000	51,000	51,000	51,000	68,000	68,000	85,000	102,000
		Low	23,000	35,000	35,000	35,000	47,000	47,000	59,000	70,000
Certified Temperature Rise Range - °F (°C)		High	30-60 (17-33)	30-60 (17-33)	25-55 (14-31)	25-55 (14-31)	40-70 (22-39)	25-55 (14-31)	40-70 (22-39)	40-70 (22-39)
		Low	20-50 (11-28)	30-60 (17-33)	15-45 (8-25)	15-45 (8-25)	30-60 (17-33)	15-45 (8-25)	25-55 (14-31)	25-55 (14-31)
AFUE [†]		80%								
AIRFLOW CAPACITY AND BLOWER DATA										
Rated Certified External Static Pressure	Heating	0.10	0.12	0.12	0.12	0.15	0.15	0.20	0.20	
	Cooling	0.50	0.50	0.50	0.50	0.50	0.50	0.50	0.50	
Airflow CFM @ Rated ESP (CFM) [‡]	High Heat	630	1030	1175	1174	1175	1650	1445	1815	
	Low Heat	520	650	1040	1025	965	1445	1315	1700	
	Cooling	1565	1355	1650	2070	1455	2270	2245	2240	
Direct Drive Motor HP		3/4	1/2	3/4	1	1/2	1	1	1	
Motor Full Load Amps		8.8	6.7	8.8	11.5	6.7	11.5	11.5	11.7	
Heating Blower Control (Htg Off-Delay)		Adjustable: 90, 120 (factory-set), 150, 180 seconds								
Cooling Blower Control (Time Delay Relay)		Adjustable: 90 (factory-set), 5, 30, 60 seconds								
Blower Wheel Diameter x Width - In. (mm)		11 x 8 (279x203)	10 x 6 (254x152)	11 x 8 (279x203)	11 x 10 (279x254)	10 x 8 (254x203)	11 x 11 (279x279)	11 x 10 (279x254)	11 x 11 (279x279)	
Air Filtration System		Field Supplied Filter								
Filter used for Certified Watt Data		325531-40 ^{**}								
ELECTRICAL DATA										
Unit Volts-Hertz-Phase		115-60-1								
Operating Voltage Range	Min-Max	104-127								
Maximum Unit Amps		10.5	8.0	10.5	13.8	8.6	14.4	14.7	13.9	
Unit Ampacity		13.8	10.7	13.8	18.0	11.3	18.5	18.8	17.8	
Maximum Wire Length (Measure 1 way in Ft. (M))		26 (7.9)	34 (10.4)	26 (7.9)	31 (9.4)	32 (9.8)	31 (9.4)	30 (9.1)	32 (9.8)	
Minimum Wire Size	AWG	14	14	14	12	14	12	12	12	
Max. Fuse/Ckt Bkr Size (Time-Delay Type Recommended)	Amps	15	15	15	20	15	20	20	20	
Transformer Capacity (24 VAC output)		40VA								

SPECIFICATIONS (Continued)

UNIT SIZE		0451712	0701412	0701716	0702120	0901716	0902120	1102120	1352422
External Control Power Available	Heating	24VA							
	Cooling	35VA							
GAS CONTROLS									
Burners		2	3	3	3	4	4	5	6
Gas Connection Size		1/2-in. NPT							
Gas Valve (Redundant)	Mfr	WhiteRodgers™							
Min. inlet pressure	(in.w.c.)	4.5 (Natural Gas)							
Max. inlet pressure	(in.w.c.)	13.6 (Natural Gas)							
Ignition Device		Silicon Nitride							
Factory installed orifice		Size 43							
CONNECTIONS									
Communication System		ION™ Communicating Control SYST0101CW							
Thermostat Connections		R, W/W1, W2, Y/Y2, Y1, G, Com 24V, DHUM							
Accessory Connections		EAC-1 (115 VAC); HUM (24 VAC); 1-STG AC (via Y/Y2)							

*. Gas input ratings are certified for elevations to 2000 ft. (610 M). In USA, For elevations above 2000 ft (610 M), reduce ratings 4 percent for each 1000 ft (305 M) above sea level. Refer to National Fuel Gas Code NFPA 54/ANSI Z223.1 Table F.4 or furnace installation instructions.

†. Capacity in accordance with U.S. Government DOE test procedures.

‡. Airflow shown is for bottom only return-air supply for the as-shipped speed tap. For air delivery above 1800 CFM, see Air Delivery table for other options. A filter is required for each return-air supply. An airflow reduction of up to 7 percent may occur when using the factory-specified 4-5/16-in. (110 mm) wide, high efficiency media filter.

**. See Accessory List for part numbers available.

AIR DELIVERY—CFM (With Filter)*

0451712													
Available Cooling Airflow Settings (CFM)	488	525	555	600	650	700	740	*800	875	925	975	1000	†1050
	1138	1200	1225	1300	1400	1480	1600						
Available Constant Fan Airflow Settings (CFM)	‡488	525	555	600	650	700	740	800	875	925	975	1000	1050
	1138	1200	1225										
Airflow reduces by 2% - 3% per 0.1 of ESP above the noted static for these airflow settings	Airflow	ESP (in. w.c.)											
	1400	0.7											
	1480	0.5											
	1600	0.3											
Max Cooling ESP	0.1	0.2	0.3	0.4	0.5	0.6	0.7	0.8	0.9	1			
**Max Cooling CFM	1695	1670	1640	1605	1565	1530	1490	1445	1400	1360			

0701412													
Available Cooling Airflow Settings (CFM)	400	450	488	525	555	600	650	700	740	*800	875	925	975
	1000	†1050	1138	1200	1225	1300	1400						
Available Constant Fan Airflow Settings (CFM)	‡400	450	488	525	555	600	650	700	740	800	875	925	975
	1000	1050	1138										
Airflow reduces by 2% - 3% per 0.1 of ESP above the noted static for these airflow settings	Airflow	ESP (in. w.c.)											
	1200	0.8											
	1225	0.8											
	1300	0.6											
1400	0.4												
Max Cooling ESP	0.1	0.2	0.3	0.4	0.5	0.6	0.7	0.8	0.9	1			
**Max Cooling CFM	1430	1430	1420	1390	1355	1315	1275	1235	1195	1155			

0701716													
Available Cooling Airflow Settings (CFM)	488	525	555	600	650	700	740	800	875	925	975	1000	*1050
	1138	1200	1225	1300	†1400	1480	1600						
Available Constant Fan Airflow Settings (CFM)	‡488	525	555	600	650	700	740	800	875	925	975	1000	1050
	1138	1200	1225										
Airflow reduces by 2% - 3% per 0.1 of ESP above the noted static for these airflow settings	Airflow Setting	ESP (in. w.c.)											
	1480	0.9											
	1600	0.7											
Max Cooling ESP	0.1	0.2	0.3	0.4	0.5	0.6	0.7	0.8	0.9	1			
**Max Cooling CFM	1655	1655	1655	1655	1650	1645	1615	1570	1520	1475			

0702120													
Available Cooling Airflow Settings (CFM)	650	700	740	800	875	925	975	1000	1050	1138	1200	1225	*1300
	1400	1480	1600	1625	†1750	1850	1911	2000					
Available Constant Fan Airflow Settings (CFM)	‡650	700	740	800	875	925	975	1000	1050	1138	1200	1225	1300
	1400	1480	1600										
Airflow reduces by 2% - 3% per 0.1 of ESP above the noted static for these airflow settings	Airflow	ESP (in. w.c.)											
	1850	0.9											
	1911	0.8											
	2000	0.5											
Max Cooling ESP	0.1	0.2	0.3	0.4	0.5	0.6	0.7	0.8	0.9	1			
**Max Cooling CFM	2095	2095	2100	2100	2070	2035	1995	1960	1920	1880			

AIR DELIVERY—CFM (With Filter)* (Continued)

0901716													
Available Cooling Airflow Settings (CFM)	400	450	488	525	555	600	650	700	740	800	875	925	975
	1000	*1050	1138	1200	1225	1300	†1400	1480	1600				
Available Constant Fan Airflow Settings (CFM)	‡400	450	488	525	555	600	650	700	740	800	875	925	975
	1000	1050	1138										
Airflow reduces by 2% - 3% per 0.1 of ESP above the noted static for these airflow settings	Airflow		ESP (in. w.c.)										
	1300		0.9										
	1400		0.7										
	1480		0.5										
	1600		0.1										
Max Cooling ESP	0.1	0.2	0.3	0.4	0.5	0.6	0.7	0.8	0.9	1			
**Max Cooling CFM	1595	1560	1525	1490	1455	1420	1385	1340	1280	1220			

0902120													
Available Cooling Airflow Settings (CFM)	650	700	740	800	875	925	975	1000	1050	1138	1200	1225	*1300
	1400	1480	1600	1625	†1750	1850	1911	2000	2100	2179	2200		
Available Constant Fan Airflow Settings (CFM)	‡650	700	740	800	875	925	975	1000	1050	1138	1200	1225	1300
	1400	1480	1600										
Airflow reduces by 2% - 3% per 0.1 of ESP above the noted static for these airflow settings	Airflow Setting		ESP (in. w.c.)										
	2000		0.8										
	2100		0.7										
	2179		0.6										
	2200		0.5										
Max Cooling ESP	0.1	0.2	0.3	0.4	0.5	0.6	0.7	0.8	0.9	1			
**Max Cooling CFM	2290	2290	2290	2285	2270	2230	2185	2130	2070	2015			

1102120													
Available Cooling Airflow Settings (CFM)	650	700	740	800	875	925	975	1000	1050	1138	1200	1225	*1300
	1400	1480	1600	1625	†1750	1850	1911	2000	2100	2179	2200		
Available Constant Fan Airflow Settings (CFM)	‡650	700	740	800	875	925	975	1000	1050	1138	1200	1225	1300
	1400	1480	1600										
Airflow reduces by 2% - 3% per 0.1 of ESP above the noted static for these airflow settings	Airflow Setting		ESP (in. w.c.)										
	2000		0.9										
	2100		0.7										
	2179		0.6										
	2200		0.5										
Max Cooling ESP	0.1	0.2	0.3	0.4	0.5	0.6	0.7	0.8	0.9	1			
**Max Cooling CFM	2270	2270	2270	2270	2245	2200	2150	2100	2050	1995			

1352422													
Available Cooling Airflow Settings (CFM)	550	600	650	700	740	800	875	925	975	1000	1050	1138	1200
	1225	1300	*1400	1480	1600	1625	1750	1850	†1911	2000	2100	2179	
Available Constant Fan Airflow Settings (CFM)	‡550	600	650	700	740	800	875	925	975	1000	1050	1138	1200
	1225	1300	1400										
Airflow reduces by 2% - 3% per 0.1 of ESP above the noted static for these airflow settings	Airflow Setting		ESP (in. w.c.)										
	1911		0.9										
	2000		0.7										
	2100		0.6										
	2250		0.4										
Max Cooling ESP	0.1	0.2	0.3	0.4	0.5	0.6	0.7	0.8	0.9	1			
**Max Cooling CFM	2270	2255	2255	2245	2240	2200	2135	2070	2010	1945			

*. Low Cooling Default
 †. High Cooling Default
 ‡. Constant Fan Default **Not Recommended**
 **. Max Cooling values are test CFM all other airflows are standard CFM

TYPICAL WIRING SCHEMATIC

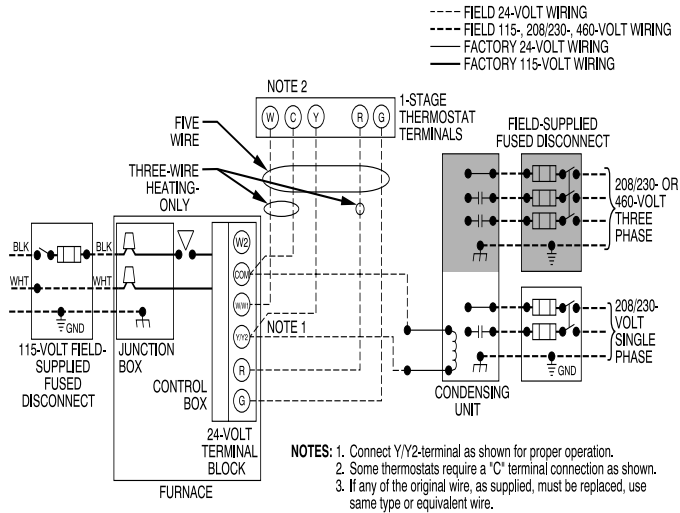

A95236

FURNACE CONTROL BOARD

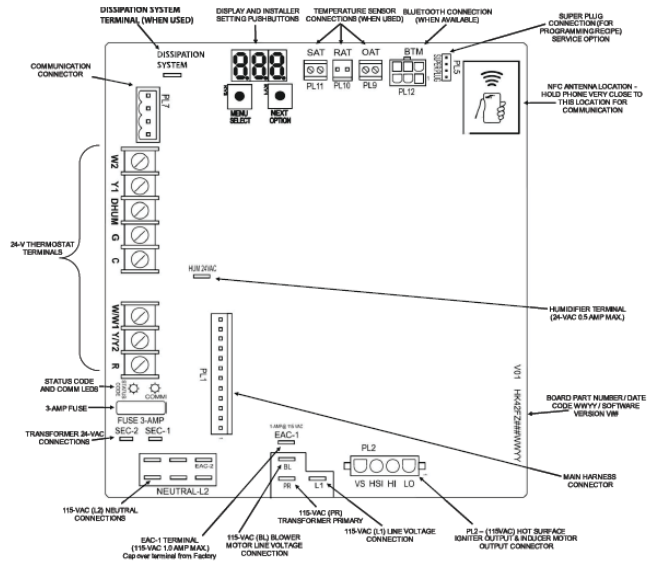

A230451

VENTING CONFIGURATIONS

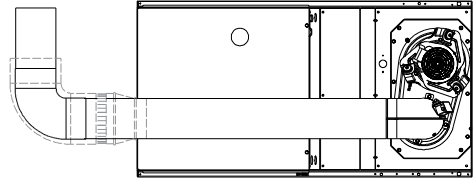

SEE NOTES: 1,2,4,5,7,8,9

HORIZONTAL RIGHT

A02068

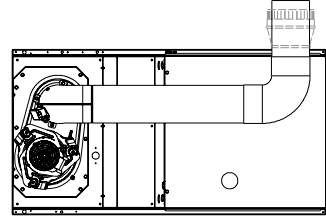

SEE NOTES: 1,2,4,5,7,8,9

HORIZONTAL LEFT

A02065

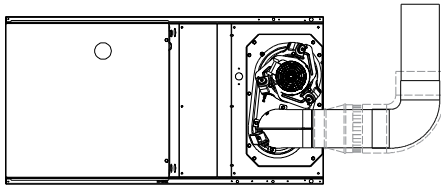

SEE NOTES: 1,2,4,7,8,9

HORIZONTAL RIGHT

A02069

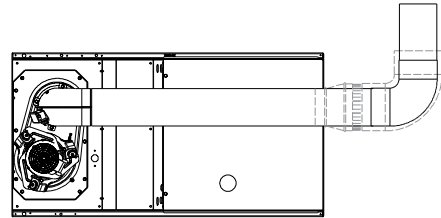

SEE NOTES: 1,2,4,5,7,8,9

HORIZONTAL LEFT

A02067

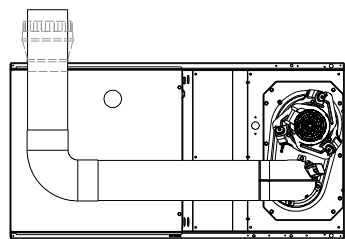

SEE NOTES: 1,2,4,5,7,8,9

HORIZONTAL RIGHT

A02070

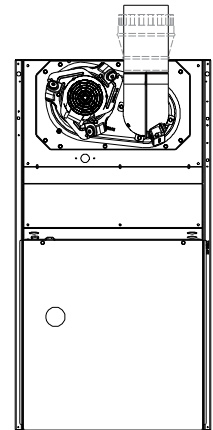

SEE NOTES: 1,2,4,7,8,9

UPFLOW

A02058

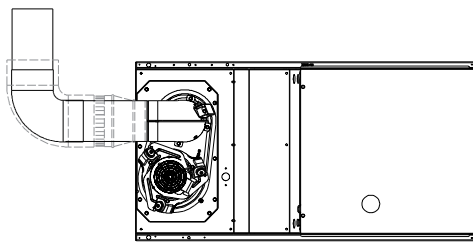

SEE NOTES: 1,2,4,7,8,9

HORIZONTAL LEFT

A02064

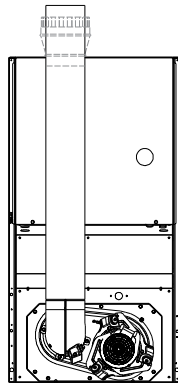

SEE NOTES: 1,2,4,5,7,8,9

DOWNFLOW

A02061

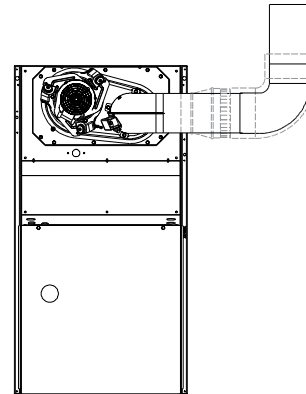

SEE NOTES: 1,2,3,4,7,8,9

UPFLOW

A02059

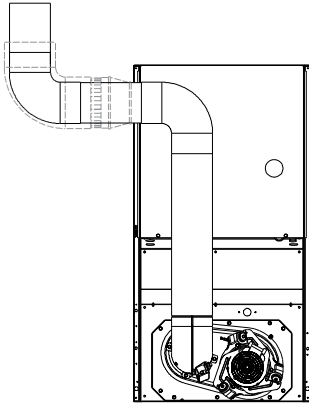

SEE NOTES:1,2,3,4,5,7,8,9

DOWNFLOW

A02060

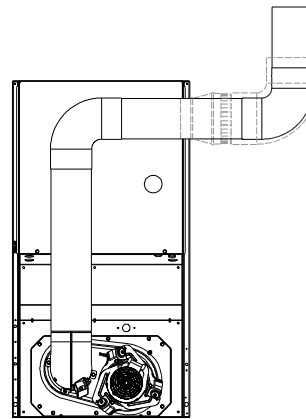

SEE NOTES: 1,2,3,4,7,8,9

DOWNFLOW

A02063

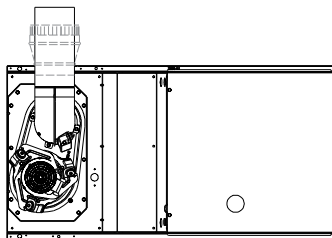

SEE NOTES: 1,2,4,5,7,8,9

HORIZONTAL LEFT

A02066

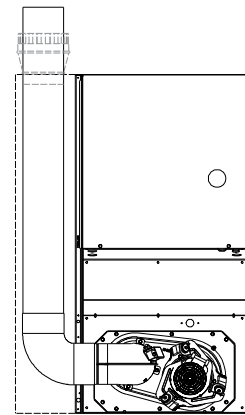

SEE NOTES: 1,2,4,5,6,7,8,9

DOWNFLOW

A02062

VENTING NOTES

1. For common vent, vent connector sizing and vent material: United States, latest edition of the National Fuel Gas Code (NFGC), ANSI Z223.1/NFPA 54.
2. Immediately increase to 5-in. (127 mm) vent connector outside furnace casing when 5-in. (127 mm) vent connector required, refer to Note 1.
3. Side outlet vent for upflow and downflow installations must use Type B vent immediately after exiting the furnace, except when Downflow Vent Guard is used in downflow position.
4. Type B vent where required, refer to Note 1.
5. 4-in. (102 mm) single wall vent must be used inside furnace casing and the Downflow Vent Guard Kit.
6. Accessory Downflow Vent Guard Kit required in downflow installations with bottom vent configuration.
7. Chimney Adapter Kit required for exterior masonry chimney applications. Refer to Chimney Adapter Kits for sizing and complete application details.
8. Secure vent connector to furnace elbow with (2) corrosion-resistant sheet metal screws, space approximately 180 apart.
9. Secure all other single wall vent connector joints with (3) corrosion-resistant screws spaced approximately 120 apart. Secure Type B vent connectors per vent connector manufacturer's recommendations.

ACCESSORIES

PART NUMBER	DESCRIPTION	0451712	0701412	0701716	0702120
ACG1425NCB*	External Filter Rack, 14-1/2 x 25"	-	X	-	-
ACG1625NCF*	External Filter Rack, 16 x 25"	X	-	-	-
ACG2025NCJ*	External Filter Rack, 20 x 25"	-	-	X	X
325531-402*	Washable filter, 3/4" x 16" x 25"	X	X	X	-
325531-403*	Washable filter, 3/4" x 21" x 25"	-	-	-	X
NAHB00101CA	Coil Adapter Kits - No Offset	X	X	X	X
NAHB00201CA	Coil Adapter Kits - Single Offset	X	X	X	X
NAHB00301CA	Coil Adapter Kits - Double Offset	X	X	X	X
NAHA00401DH	Chimney Adapter Kit, up to or equal to 110K BTUh	X	X	X	X
NAHA01101SB	Combustible Floor Base (Not required when evaporator coil case is used for downflow)	X	X	X	X
NAHB00301VC	Downflow Vent Guard (Not required when vent is routed through cabinet)	X	X	X	X
AGAGC8NPS01B*	Natural-to-Propane Conversion Kit †	X	X	X	X
AGAGC8PNS01B*	Propane-to-Natural Conversion Kit †	X	X	X	X
NAHA00201HL	High Altitude Kit	X	X	X	X
SYST0101CW	ION™ Communicating Control	X	X	X	X

* Purchased through FAST Parts.

† Factory authorized and field installed. Gas conversion kits are CSA recognized.

X Accessory

PART NUMBER	DESCRIPTION	0901716	0902120	1102120	1352422
ACG1625NCF*	External Filter Rack, 16 x 25"	X	-	-	-
ACG2025NCJ*	External Filter Rack, 20 x 25"	-	X	X	-
ACG2424NCL*	External Filter Rack, 24-1/2" x 24"	-	-	-	X
325531-402*	Washable filter, 3/4" x 16" x 25"	X	-	-	-
325531-403*	Washable filter, 3/4" x 21" x 25"	-	X	X	-
325531-404*	Washable filter, 3/4" x 24" x 25"	-	-	-	X
NAHB00101CA	Coil Adapter Kits - No Offset	X	X	X	X
NAHB00201CA	Coil Adapter Kits - Single Offset	X	X	X	X
NAHB00301CA	Coil Adapter Kits - Double Offset	X	X	X	X
NAHA00401DH	Chimney Adapter Kit, up to or equal to 110K BTUh	X	X	X	-
NAHA00301DH	Chimney Adapter Kit, greater than or equal to 135K BTUh	-	-	-	X
NAHA01101SB	Combustible Floor Base (Not required when evaporator coil case is used for downflow)	X	X	X	X
NAHB00301VC	Downflow Vent Guard (Not required when vent is routed through cabinet)	X	X	X	X
AGAGC8NPS01B*	Natural-to-Propane Conversion Kit †	X	X	X	X
AGAGC8PNS01B*	Propane-to-Natural Conversion Kit †	X	X	X	X
NAHA00201HL	High Altitude Kit	X	X	X	X
SYST0101CW	ION™ Communicating Control	X	X	X	X

* Purchased through FAST Parts.

† Factory authorized and field installed. Gas conversion kits are CSA recognized.

X Accessory

ORIFICES

Part Number	Gas Type	Orifice Size	Part Number	Gas Type	Orifice Size	Part Number	Gas Type	Orifice Size
1185612	Natural	42	1183809	Natural	46	1184256	Propane	54
1176928	Natural	43	1185613	Natural	47	1185615	Propane	55
1185574	Natural	44	1185614	Natural	48	1185616	Propane	56
1177213	Natural	45				1185617	Propane	1.25 mm
						1185618	Propane	1.30 mm