

# TECHNICAL GUIDE

## ADD - ON COILS FOR USE WITH SPLIT-SYSTEM COOLING & HEAT PUMPS

MODELS: MC, PC, FC, HD, UC  
600 - 2000 CFM 1.5 - 5 TON COILS



UPFLOW/DOWNFLOW  
FULL CASED  
FC



FULL CASED  
MULTI-POSITION  
MC

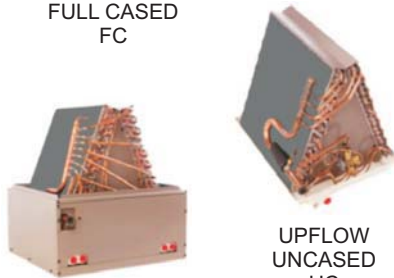

UPFLOW  
UNCASED  
UC



UPFLOW  
PARTIAL CASED  
PC



HORIZONTAL  
DUCT  
HD



Due to continuous product improvement, specifications are subject to change without notice.

Visit us on the web at [www.york.com](http://www.york.com) for the most up-to-date technical information.

Additional rating information can be found at [www.ahridirectory.org](http://www.ahridirectory.org)

## DESCRIPTION

These evaporator coils are designed to be installed with UPG furnaces or modular air handlers and matched with UPG cooling and heat pump outdoor units. All coil models are available as "flex-coil" units without a factory installed metering device. Flex-coil models allow these coils to be used with R-22 or R-410A for added flexibility to meet refrigerant system choice. An orifice metering device or a R-410A TXV should be installed in the field to meet your system requirements.

**FC Models, Full Case Coils** - Full cased coils are suitable for use in upflow or downflow applications.

**MC Models, Multi-Position Coils** - MC coils have the added flexibility that allow them to be installed in any position - upflow, downflow, or horizontal right or left. This coil can be easily installed with a UPG furnace or modular air handler in any configuration.

**PC Models, Partial Case Coils** - These coils are designed for installation on top of upflow furnaces. The partial case height on these coils allows for the flexibility of fabricating the upper portion of the coil casing in the field. The partial cased coils are for use in upflow only applications.

**UC Models, Uncased Coils** - These coils are designed for installation on top of upflow furnaces, and they are to be used for only upflow applications. The uncased coils allows field modification of the furnace duct for the coil installation.

**HD Models, Horizontal Duct Coils** - Dedicated horizontal, slab coil available for both cooling and heat pump applications. Field transition may be required.

## FEATURES

**Rust-proof plastic drain pans** - The vertical and horizontal drain pans on these coils are made of a fiberglass reinforced thermoset polymer that will not rust or compromise stability at high temperatures.

**Insulated Cabinet** - Evaporator coil cabinets are thermally insulated with foil faced insulation to prevent sweating. HD coils use fiberglass Tuf-Skin® insulation.

**Internally Clean** - All evaporator coils are factory leak-tested, dehydrated, sealed and shipped with a holding charge. The suction and liquid lines are sealed with spun copper fittings with easy access to attach line set.

**Durable Finish Inside and Out** - Coil casings are made of pre-painted steel. Pre-treated flat galvanized steel provides a better paint to steel bond, which resists corrosion and rust creep. All internal metal parts are made of G90 galvanized steel.

**Optimum Heat Transfer** - Using the latest in heat transfer technology, staggered rows of copper tubes are mechanically expanded into aluminum fins to provide optimum air to surface contact for ample moisture removal as well as high performance ratings.

## ACCESSORIES

Refer to Price Manual for specific model numbers.

**TXV Kits** - Thermal expansion valve kits are available for flex-coil applications, for converting R-22 to R-410A refrigerant, or as a service replacement. All TXV kits are non-braze. All connections are bolt-on including the valve assembly and equalizer tube. No orifice or any other metering device is to be used in conjunction with the TXV.

**Coil Casing Without Coil** - Coil casings are available in four widths that can be installed with the furnace or modular air handler during initial installation. This option is available to allow the installer the flexibility to add the coil at a later date without duct modifications.

**UVC Germicidal Light** - The UVC technology effectively prevents mold, bacteria, and other microorganisms that develop in air handling systems. The UVC Light Kit provides safe, continuous cleaning while actually saving money by reducing HVAC system maintenance and energy consumption.

**COOLING CAPACITY - Coil Only<sup>1</sup>**

Model	Rated CFM	Entering Air °F (Dry/Wet Bulb)	MBH @ Evaporator Temperature and Corresponding Pressure °F / PSIG			
			35 / 61.5	40 / 68.5	45 / 76.0	50 / 84.0
<b>UPFLOW "A" TYPE</b>						
FC18A PC18A	675	85/72	25.3	23.1	20.6	17.9
		80/67	23.4	21.1	18.7	16.1
		75/62	19.2	12.0	18.7	12.4
		70/57	15.6	13.5	11.3	8.8
FC18B PC18B	675	85/72	28.1	25.7	22.9	19.9
		80/67	26.0	23.5	20.8	17.9
		75/62	21.3	18.9	16.4	13.7
		70/57	17.3	15.0	12.6	9.8
FC24A PC24A	850	85/72	35.6	32.5	29.0	25.2
		80/67	32.9	29.7	26.3	22.7
		75/62	27.0	23.9	20.7	17.4
		70/57	21.9	19.0	15.9	12.4
FC24B PC24B	850	85/72	35.6	32.5	29.0	25.2
		80/67	32.9	29.7	26.3	22.7
		75/62	27.0	23.9	20.7	17.4
		70/57	21.9	19.0	15.9	12.4
FC30(A,B) PC30(A,B) FC32A PC32A	1025	85/72	38.9	35.4	31.6	27.6
		80/67	33.9	30.3	26.8	23.0
		75/62	27.3	23.7	22.5	18.0
		70/57	22.6	20.1	17.5	14.8
FC35(B,C) PC35(B,C) FC37A PC37A	1200	85/72	58.7	50.5	42.1	33.2
		80/67	47.0	39.5	32.2	24.6
		75/62	36.7	29.2	23.8	19.9
		70/57	31.5	27.6	22.4	18.8
FC36A PC36A	1150	85/72	46.0	41.9	37.4	32.9
		80/67	36.8	32.5	28.5	24.2
		75/62	28.8	24.1	26.4	19.6
		70/57	24.7	22.9	21.1	19.6
FC36(B,C) PC36(B,C)	1250	85/72	51.1	46.5	41.5	36.6
		80/67	40.9	36.1	31.7	26.9
		75/62	32.0	26.8	29.3	21.8
		70/57	27.4	25.4	23.4	21.8
FC42(B,C) PC42(B,C)	1400	85/72	73.1	62.9	52.4	41.4
		80/67	58.6	49.1	40.0	30.6
		75/62	45.7	36.3	29.6	24.7
		70/57	39.2	34.3	27.9	23.4
FC43(B,C) PC43(B,C)	1400	85/72	76.8	66.0	55.0	43.4
		80/67	61.5	51.6	42.0	32.1
		75/62	47.9	38.1	31.1	26.0
		70/57	41.2	36.0	29.3	24.6
FC48(C,D) PC48(C,D)	1620	85/72	82.2	70.7	58.9	46.5
		80/67	65.8	55.3	45.0	34.4
		75/62	51.4	40.9	33.3	27.9
		70/57	44.1	38.6	32.3	26.5
FC60(C,D) PC60(C,D)	1850	85/72	100.9	85.0	68.9	52.3
		80/67	80.8	66.6	52.6	38.6
		75/62	62.9	49.3	38.8	31.2
		70/57	54.1	46.6	37.4	29.8
FC62D	1850	85/72	105.9	89.3	72.4	54.9
		80/67	84.8	70.0	55.2	40.5
		75/62	66.0	51.8	40.8	32.8
		70/57	56.8	48.9	39.3	31.2
FC64D	1850	85/72	124.4	109.4	94.1	78.0
		80/67	100.9	87.0	72.1	56.2
		75/62	80.3	66.7	52.5	37.2
		70/57	61.8	48.2	34.8	24.3

1 - See Condensing Unit or Heat Pump Technical Guide for Total Cooling Capacity and Sensible Capacity.

COOLING CAPACITY - COIL ONLY<sup>1</sup>

Model Coil	Rated CFM	Entering Air °F (Dry/Wet Bulb)	MBH@ Evaporator Temperature and Corresponding Pressure °F / PSIG			
			35 / 61.5	40 / 68.5	45 / 76.0	50 / 84.0
<b>FULL-CASED "A" TYPE MULTI-POSITION</b>						
MC18A	550	85/72	25.8	23.5	21.0	18.2
		80/67	23.7	21.5	19.0	16.4
		75/62	19.5	17.3	14.9	12.6
		70/57	15.8	13.5	11.5	9.0
MC18B	650	85/72	28.7	26.1	23.3	20.2
		80/67	26.4	23.9	21.1	18.2
		75/62	21.6	19.2	16.6	14.0
		70/57	17.5	15.2	12.8	10.0
MC24(A,B)	850	85/72	36.3	33.0	29.5	25.6
		80/67	33.4	30.2	26.7	23.1
		75/62	27.4	24.3	21.0	17.7
		70/57	22.2	19.3	16.2	12.6
MC30(A,B) MC32A	1025	85/72	41.5	37.8	33.7	29.5
		80/67	36.2	32.4	28.6	24.5
		75/62	29.1	25.3	24.0	19.2
		70/57	24.1	21.5	18.7	15.8
MC35(B,C) MC37A	1200	85/72	59.9	51.5	42.9	33.9
		80/67	48.0	40.3	32.8	25.1
		75/62	37.4	29.8	24.3	20.3
		70/57	32.1	28.1	22.9	19.2
MC36A	1150	85/72	46.8	42.6	38.1	33.6
		80/67	37.5	33.1	29.1	24.7
		75/62	29.3	24.6	26.8	20.0
		70/57	25.1	23.2	21.4	20.0
MC36B	1250	85/72	52.0	47.3	42.3	37.3
		80/67	41.7	36.8	32.3	27.4
		75/62	32.5	27.3	29.8	22.2
		70/57	27.9	25.8	23.8	22.2
MC36C	1250	85/72	53.4	48.6	43.4	38.3
		80/67	42.8	37.8	33.1	28.2
		75/62	33.4	28.1	30.6	22.8
		70/57	28.7	26.5	24.5	22.8
MC42(B,C)	1400	85/72	74.6	64.1	53.4	42.2
		80/67	59.8	50.1	40.8	31.2
		75/62	46.6	37.1	30.2	25.2
		70/57	40.0	35.0	28.5	23.9
MC43(B,C)	1400	85/72	78.3	67.4	56.1	44.3
		80/67	62.7	52.6	42.9	32.8
		75/62	48.9	38.9	31.7	26.5
		70/57	42.0	36.8	29.9	25.1
MC48(C,D)	1650	85/72	83.9	72.1	60.1	47.4
		80/67	67.2	56.4	45.9	35.1
		75/62	52.4	41.7	33.9	28.4
		70/57	45.0	39.4	33.0	27.0
MC60D	1825	85/72	102.9	86.7	70.3	53.3
		80/67	82.4	68.0	53.7	39.4
		75/62	64.2	50.3	39.6	31.8
		70/57	55.1	47.5	38.1	30.3
MC62D	2000	85/72	107.0	90.2	73.1	55.5
		80/67	85.7	70.7	55.8	40.9
		75/62	66.7	52.3	41.2	33.1
		70/57	57.4	49.4	39.7	31.6

<sup>1</sup> See Condensing Unit or Heat Pump Technical Guide for Total Cooling Capacity and Sensible Capacity.

**COOLING CAPACITY - Coil Only<sup>1</sup>**

MODEL	RATED CFM	ENTERING AIR °F (Dry/Wet Bulb)	MBH @ Evaporator Temperature and Corresponding Pressure °F/ PSIG			
			35 / 61.5	40 / 68.5	45 / 76.0	50 / 84.0
<b>HORIZONTAL DUCT TYPE</b>						
HD24S	815	85/72	35.3	32.4	28.7	24.9
		80/67	32.6	29.4	26.0	22.5
		75/62	26.7	23.7	20.5	17.2
		70/57	21.7	18.8	15.7	12.3
HD36S	1192	85/72	57.9	52.7	47.1	41.5
		80/67	46.4	41.1	35.9	30.4
		75/62	36.2	30.4	26.5	24.7
		70/57	31.1	28.7	26.5	24.7
HD48S	1610	85/72	83.4	71.7	59.7	47.1
		80/67	66.8	56.1	45.6	34.9
		75/62	52.1	41.5	33.7	28.3
		70/57	44.7	39.2	33.7	28.3
HD60S	2100	85/72	133.0	112.4	90.9	69.2
		80/67	106.5	87.9	69.4	50.0
		75/62	83.0	65.0	51.3	41.1
		70/57	71.2	61.4	51.3	41.1

<sup>1</sup> See Condensing Unit or Heat Pump Technical Guide for Total Cooling Capacity and Sensible Capacity.

**COOLING CAPACITY - COIL ONLY<sup>1</sup>**

Model Coil	Rated CFM	Entering Air °F (Dry/Wet Bulb)	MBH @ Evaporator Temperature and Corresponding Pressure °F/ PSIG			
			35 / 61.5	40 / 68.5	45 / 76.0	50 / 84.0
<b>Uncased Upflow</b>						
UC18(A,B)	600	85/72	23.3	21.3	19.0	17.5
		80/67	21.5	19.5	17.3	14.9
		75/62	17.7	15.6	13.5	11.4
		70/57	14.4	12.4	10.4	8.0
UC24(A,B)	800	85/72	27.4	25.0	22.3	19.4
		80/67	25.3	22.9	20.3	17.5
		75/62	20.8	18.4	15.9	13.4
		70/57	16.9	14.6	12.2	9.4
UC30(A,B)	1000	85/72	35.2	32.0	28.6	24.8
		80/67	32.4	28.6	25.3	21.9
		75/62	26.6	23.6	21.5	18.7
		70/57	25.2	22.7	20.2	17.6
UC36A	1150	85/72	46.8	42.7	37.9	33.0
		80/67	43.1	39.2	34.9	30.4
		75/62	35.3	32.1	28.6	24.9
		70/57	33.3	26.9	26.9	23.4
UC36(B,C)	1200	85/72	49.3	44.9	39.9	34.7
		80/67	45.4	41.3	36.7	32.0
		75/62	37.2	33.8	30.1	26.2
		70/57	35.0	28.3	28.3	24.6
UC42(B,C)	1400	85/72	86.7	73.0	59.2	44.9
		80/67	69.4	57.2	45.2	33.1
		75/62	54.0	42.3	33.4	26.8
		70/57	46.4	40.0	33.4	26.8
UC48(C,D)	1600	85/72	62.4	56.8	50.5	44.4
		80/67	57.4	53.2	46.5	40.5
		75/62	47.1	42.8	38.1	33.2
		70/57	44.3	40.3	35.8	31.2
UC60(C,D)	1800	85/72	95.4	82.1	68.4	54.0
		80/67	76.4	64.1	52.2	39.9
		75/62	59.6	47.4	38.6	32.4
		70/57	51.2	44.8	38.6	32.4

<sup>1</sup> See Condensing Unit or Heat Pump Technical Guide for Total Cooling Capacity and Sensible Capacity.

**APPLICATION FACTOR-RATED CFM VS. ACTUAL CFM**

% OF RATED AIR FLOW	80%	90%	RATED CFM	110%	120%
CAPACITY FACTOR	0.96	0.98	1.00	1.02	1.03

\* Do not exceed minimum/maximum CFM limits shown under Air Flow Data.

**APPLICATION LIMITATIONS**

These units must be installed in accordance with all national and local safety codes.

Air flow must be within the minimum and maximum limits approved for electric heat, evaporator coils and outdoor units.

**STATIC PRESSURE VS. AIRFLOW  
(BASED ON WET COIL)****HORIZONTAL - DUCT TYPE**

Model	Airflow	Wet Coil
HD24S	600	0.02
	800	0.09
	1000	0.19
HD36S	1000	0.19
	1200	0.28
	1400	0.38
HD48S	1200	0.14
	1400	0.19
	1600	0.25
	1800	0.32
HD60S	1600	0.16
	1800	0.20
	2000	0.25
	2200	0.30

**UNCASED UPFLOW - "A" TYPE**

Model	Airflow	Wet Coil
UC18A	600	0.16
	800	0.23
	1000	0.30
UC18B	600	0.14
	800	0.20
	1000	0.26
UC24A	600	0.15
	800	0.21
	1000	0.27
UC24B	600	0.13
	800	0.18
	1000	0.23
UC30A	800	0.21
	1000	0.27
	1200	0.33
UC30B	800	0.18
	1000	0.23
	1200	0.29
UC36A	1000	0.24
	1200	0.32
	1400	0.40
UC36B	1000	0.15
	1200	0.22
	1400	0.28
UC36C	1000	0.10
	1200	0.15
	1400	0.20
UC42B	1200	0.21
	1400	0.28
	1600	0.34
UC42C	1200	0.14
	1400	0.19
	1600	0.24
	1800	0.28
UC48C	1200	0.18
	1400	0.24
	1600	0.29
	1800	0.35
UC48D	1200	0.14
	1400	0.20
	1600	0.25
	1800	0.30
UC60C	1600	0.28
	1800	0.33
	2000	0.38
	2200	0.43
UC60D	1600	0.21
	1800	0.27
	2000	0.32
	2200	0.38

## UPFLOW CASED "A" TYPE

Model	Airflow	Wet Coil
FC18A PC18A	600	0.16
	800	0.23
	1000	0.30
FC18B PC18B	600	0.14
	800	0.20
	1000	0.26
FC24A PC24A	600	0.15
	800	0.21
	1000	0.27
FC24B PC24B	600	0.13
	800	0.18
	1000	0.23
FC30A, PC30A FC32A, PC32A	800	0.21
	1000	0.27
	1200	0.33
FC30B PC30B	800	0.18
	1000	0.23
	1200	0.29
FC35B PC35B	800	0.16
	1000	0.22
	1200	0.29
FC35C PC35C	800	0.14
	1000	0.20
	1200	0.27
FC36A PC36A	1000	0.24
	1200	0.32
	1400	0.40
FC36B PC36B	1000	0.15
	1200	0.22
	1400	0.28
FC37A PC37A	800	0.13
	1000	0.19
	1200	0.26
FC36C PC36C	1000	0.10
	1200	0.15
	1400	0.20
FC42B PC42B	1200	0.21
	1400	0.28
	1600	0.34
FC42C, PC42C FC43B, PC43B	1800	0.40
	1200	0.14
	1400	0.19
FC43C PC43C	1600	0.24
	1800	0.28
	1000	0.15
FC48C PC48C	1200	0.21
	1400	0.28
	1600	0.34
FC48D PC48D	1600	0.29
	1800	0.35
	2000	0.40
FC60C PC60C	2200	0.46
	1600	0.25
	1800	0.30
FC60D PC60D	2000	0.35
	2200	0.40
	1600	0.28
FC62D	1800	0.33
	2000	0.38
	2200	0.43
FC64D	1600	0.21
	1800	0.27
	2000	0.32
FC64D	2200	0.38
	1600	0.18
	1800	0.23
FC64D	2000	0.29
	1600	0.21
	1800	0.26
FC64D	2000	0.30

## CASED "A" TYPE MULTI-POSITION

Model	Airflow	Wet Coil
MC18A	600	0.22
	800	0.29
	1000	0.36
MC18B	600	0.20
	800	0.26
	1000	0.32
MC24A	600	0.21
	800	0.27
	1000	0.33
MC24B	600	0.19
	800	0.24
	1000	0.29
MC30A MC32A	600	0.21
	800	0.27
	1000	0.33
MC30B	600	0.19
	800	0.24
	1000	0.29
MC35B	600	0.22
	800	0.26
	1000	0.34
MC35C	600	0.20
	800	0.24
	1000	0.32
MC36A	800	0.22
	1000	0.30
	1200	0.38
MC37A	800	0.19
	1000	0.25
	1200	0.32
MC36B	800	0.15
	1000	0.21
	1200	0.28
MC36C	1000	0.16
	1200	0.21
	1400	0.26
MC42B	1200	0.27
	1400	0.34
	1600	0.40
MC42C	1200	0.20
	1400	0.25
	1600	0.30
MC43C	1800	0.34
	1200	0.26
	1400	0.31
MC48C	1600	0.36
	1800	0.41
	1200	0.24
MC48D	1400	0.30
	1600	0.35
	1800	0.41
MC60D	1200	0.20
	1400	0.26
	1600	0.31
MC62D	1800	0.36
	1600	0.27
	1800	0.33
MC62D	2000	0.38
	2200	0.44
	1600	0.24
MC62D	1800	0.29
	2000	0.34

**PHYSICAL DATA****UNCASED UPFLOW - "A" TYPE**

Model	Application	Refrig. Conn. Types	Face Area (Sq. Ft.)	Rows Deep	Fin Per In.	Coil Size	Tube Geometry	Tube Dia.	Fin Type	TXV	Operating Weight (Lbs.)
UC18A3XC1	Cooling/ Heat Pump	Sweat	3.67	2	14	(2) 16 x 16.5	1 x 0.866	3/8	Enhanced	None	18
UC18B3XC1		Sweat	3.67	2	14	(2) 16 x 16.5	1 x 0.866	3/8	Enhanced	None	20
UC24A3XC1	Cooling/ Heat Pump	Sweat	4.58	2	14	(2) 20 x 16.5	1 x 0.866	3/8	Enhanced	None	22
UC24B3XC1		Sweat	4.58	2	14	(2) 20 x 16.5	1 x 0.866	3/8	Enhanced	None	23
UC30A3XC1	Cooling/ Heat Pump	Sweat	4.58	2	14	(2) 20 x 16.5	1 x 0.866	3/8	Enhanced	None	22
UC30B3XC1		Sweat	4.58	2	14	(2) 20 x 16.5	1 x 0.866	3/8	Enhanced	None	23
UC36A3XC1	Cooling/ Heat Pump	Sweat	5.04	2	14	(2) 22 x 16.5	1 x 0.866	3/8	Enhanced	None	25
UC36B3XC1		Sweat	5.04	2	14	(2) 22 x 16.5	1 x 0.866	3/8	Enhanced	None	28
UC36C3XC1		Sweat	5.04	2	14	(2) 22 x 16.5	1 x 0.866	3/8	Enhanced	None	30
UC42B3XC1	Cooling/ Heat Pump	Sweat	5.96	2	14	(2) 26 x 16.5	1 x 0.866	3/8	Enhanced	None	34
UC42C3XC1		Sweat	5.96	2	14	(2) 26 x 16.5	1 x 0.866	3/8	Enhanced	None	36
UC48C3XC1	Cooling/ Heat Pump	Sweat	5.50	3	12	(2) 24 x 16.5	1 x 0.866	3/8	Enhanced	None	38
UC48D3XC1		Sweat	5.50	3	12	(2) 24 x 16.5	1 x 0.866	3/8	Enhanced	None	42
UC60C3XC1	Cooling/ Heat Pump	Sweat	5.96	3	12	(2) 26 x 16.5	1 x 0.866	3/8	Enhanced	None	42
UC60D3XC1		Sweat	5.96	3	12	(2) 26 x 16.5	1 x 0.866	3/8	Enhanced	None	45

**HORIZONTAL - DUCT TYPE**

Model	Application	Refrig. Conn. Types	Face Area (Sq. Ft.)	Rows Deep	Fin Per In.	Coil Size	Tube Geometry	Tube Dia.	Fin Type	TXV	Operating Weight (Lbs.)
HD24S3XC1	Cooling/ Heat Pump	Sweat	3.67	3	12	22 x 24	1 x 0.866	3/8	Enhanced	None	33
HD36S3XC1	Cooling/ Heat Pump	Sweat	3.67	3	12	26 x 24	1 x 0.866	3/8	Enhanced	None	35
HD48S3XC1	Cooling/ Heat Pump	Sweat	3.67	3	12	26 x 30	1 x 0.866	3/8	Enhanced	None	38
HD60S3XC1	Cooling/ Heat Pump	Sweat	3.67	3	12	28 x 30	1 x 0.866	3/8	Enhanced	None	46

**CASED UPFLOW/DOWNFLOW AND PARTIAL CASED**

Model	Application	Refrig. Conn. Types	Face Area (Sq. Ft.)	Rows Deep	Fin Per In.	Coil Size	Tube Geometry	Tube Dia.	Fin Type	TXV	Operating Weight (Lbs.)
FC18A3XC1	Cooling/ Heat Pump	Sweat	3.4	2	14	(2) 14 x 17.5	1 x 0.866	3/8	Enhanced	None	42
FC18B3XC1	Cooling/ Heat Pump	Sweat	3.4	2	14	(2) 14 x 17.5	1 x 0.866	3/8	Enhanced	None	44
FC24A3XC1	Cooling/ Heat Pump	Sweat	4.38	2	14	(2) 18 x 17.5	1 x 0.866	3/8	Enhanced	None	46
FC24B3XC1	Cooling/ Heat Pump	Sweat	4.38	2	14	(2) 18 x 17.5	1 x 0.866	3/8	Enhanced	None	50
FC30A3XC1	Cooling/ Heat Pump	Sweat	4.38	2	14	(2) 18 x 17.5	1 x 0.866	3/8	Enhanced	None	46
FC30B3XC1	Cooling/ Heat Pump	Sweat	4.38	2	14	(2) 18 x 17.5	1 x 0.866	3/8	Enhanced	None	50
FC32A3XC1	Cooling/ Heat Pump	Sweat	3.9	3	12	(2) 16 x 17.5	1 x 0.866	3/8	Enhanced	None	49
FC35B3XC1	Cooling/ Heat Pump	Sweat	3.9	3	12	(2) 16 x 17.5	1 x 0.866	3/8	Enhanced	None	53
FC35C3XC1	Cooling/ Heat Pump	Sweat	3.9	3	12	(2) 16 x 17.5	1 x 0.866	3/8	Enhanced	None	55
FC36A3XC1	Cooling/ Heat Pump	Sweat	4.86	2	14	(2) 20 x 17.5	1 x 0.866	3/8	Enhanced	None	49
FC36B3XC1	Cooling/ Heat Pump	Sweat	4.86	2	14	(2) 20 x 17.5	1 x 0.866	3/8	Enhanced	None	51

**CASED UPFLOW/DOWNFLOW AND PARTIAL CASED**

Model	Application	Refrig. Conn. Types	Face Area (Sq. Ft.)	Rows Deep	Fin Per In.	Coil Size	Tube Geometry	Tube Dia.	Fin Type	TXV	Operating Weight (Lbs.)
FC36C3XC1	Cooling/Heat Pump	Sweat	4.86	2	14	(2) 20 x 17.5	1 x 0.866	3/8	Enhanced	None	53
FC37A3XC1	Cooling/Heat Pump	Sweat	4.86	3	12	(2) 20 x 17.5	1 x 0.866	3/8	Enhanced	None	56
FC42B3XC1	Cooling/Heat Pump	Sweat	5.83	2	14	(2) 24 x 17.5	1 x 0.866	3/8	Enhanced	None	60
FC42C3XC1	Cooling/Heat Pump	Sweat	5.83	2	14	(2) 24 x 17.5	1 x 0.866	3/8	Enhanced	None	62
FC43B3XC1	Cooling/Heat Pump	Sweat	4.86	3	12	(3) 20 x 17.5	1 x 0.866	3/8	Enhanced	None	56
FC43C3XC1	Cooling/Heat Pump	Sweat	4.86	3	12	(2) 20 x 17.5	1 x 0.866	3/8	Enhanced	None	58
FC48C3XC1	Cooling/Heat Pump	Sweat	5.35	3	12	(2) 22 x 17.5	1 x 0.866	3/8	Enhanced	None	63
FC48D3XC1	Cooling/Heat Pump	Sweat	5.35	3	12	(2) 22 x 17.5	1 x 0.866	3/8	Enhanced	None	71
FC60C3XC1	Cooling/Heat Pump	Sweat	5.83	3	12	(2) 24 x 17.5	1 x 0.866	3/8	Enhanced	None	63
FC60D3XC1	Cooling/Heat Pump	Sweat	5.83	3	12	(2) 24 x 17.5	1 x 0.866	3/8	Enhanced	None	76
FC62D3XC1	Cooling/Heat Pump	Sweat	6.8	3	12	(2) 28 x 17.5	1 x 0.866	3/8	Enhanced	None	88
FC64D3XC1	Cooling/Heat Pump	Sweat	7.78	3	13	(2) 32x17.5	1 x 0.866	3/8	Enhanced	None	92

**CASED UPFLOW "A" TYPE**

Model	Application	Refrig. Conn. Types	Face Area (Sq. Ft.)	Rows Deep	Fin Per In.	Coil Size	Tube Geometry	Tube Dia.	Fin Type	TXV	Operating Weight (Lbs.)
PC18A3XC1	Cooling/Heat Pump	Sweat	3.4	2	14	(2) 14 x 17.5	1 x 0.866	3/8	Enhanced	None	36
PC18B3XC1		Sweat	3.4	2	14	(2) 14 x 17.5	1 x 0.866	3/8	Enhanced	None	37
PC24A3XC1	Cooling/Heat Pump	Sweat	4.38	2	14	(2) 18 x 17.5	1 x 0.866	3/8	Enhanced	None	40
PC24B3XC1		Sweat	4.38	2	14	(2) 18 x 17.5	1 x 0.866	3/8	Enhanced	None	42
PC30A3XC1	Cooling/Heat Pump	Sweat	4.38	2	14	(2) 18 x 17.5	1 x 0.866	3/8	Enhanced	None	40
PC30B3XC1		Sweat	4.38	2	14	(2) 18 x 17.5	1 x 0.866	3/8	Enhanced	None	42
PC32A3XC1	Cooling/Heat Pump	Sweat	3.9	3	12	(2) 16 x 17.5	1 x 0.866	3/8	Enhanced	None	41
PC35B3XC1	Cooling/Heat Pump	Sweat	3.9	3	12	(2) 16 x 17.5	1 x 0.866	3/8	Enhanced	None	45
PC35C3XC1		Sweat	3.9	3	12	(2) 16 x 17.5	1 x 0.866	3/8	Enhanced	None	46
PC36A3XC1	Cooling/Heat Pump	Sweat	4.86	2	14	(2) 20 x 17.5	1 x 0.866	3/8	Enhanced	None	44
PC36B3XC1		Sweat	4.86	2	14	(2) 20 x 17.5	1 x 0.866	3/8	Enhanced	None	45
PC36C3XC1		Sweat	4.86	2	14	(2) 20 x 17.5	1 x 0.866	3/8	Enhanced	None	46
PC37A3XC1	Cooling/Heat Pump	Sweat	4.86	3	12	(2) 20 x 17.5	1 x 0.866	3/8	Enhanced	None	48
PC42B3XC1	Cooling/Heat Pump	Sweat	5.83	2	14	(2) 24 x 17.5	1 x 0.866	3/8	Enhanced	None	50
PC42C3XC1		Sweat	5.83	2	14	(2) 24 x 17.5	1 x 0.866	3/8	Enhanced	None	54
PC43B3XC1	Cooling/Heat Pump	Sweat	4.86	3	12	(3) 20 x 17.5	1 x 0.866	3/8	Enhanced	None	47
PC43C3XC1		Sweat	4.86	3	12	(2) 20 x 17.5	1 x 0.866	3/8	Enhanced	None	49
PC48C3XC1	Cooling/Heat Pump	Sweat	5.35	3	12	(2) 22 x 17.5	1 x 0.866	3/8	Enhanced	None	56
PC48D3XC1		Sweat	5.35	3	12	(2) 22 x 17.5	1 x 0.866	3/8	Enhanced	None	58
PC60C3XC1	Cooling/Heat Pump	Sweat	5.83	3	12	(2) 24 x 17.5	1 x 0.866	3/8	Enhanced	None	58
PC60D3XC1		Sweat	5.83	3	12	(2) 24 x 17.5	1 x 0.866	3/8	Enhanced	None	60



## FULL CASED "A" TYPE MULTI-POSITION

Model	Application	Refrig. Conn. Types	Face Area (Sq. Ft.)	Rows Deep	Fin Per In.	Coil Size	Tube Geometry	Tube Dia.	Fin Type	TXV	Operating Weight (Lbs.)
MC18A3XC1	Cooling / Heat Pump	Sweat	3.40	2	14	(2) 14 x 17.5	1 x 0.866	3/8	Enhanced	None	51
MC18B3XC1	Cooling / Heat Pump	Sweat	3.40	2	14	(2) 14 x 17.5	1 x 0.866	3/8	Enhanced	None	51
MC24A3XC1	Cooling / Heat Pump	Sweat	4.38	2	14	(2) 18 x 17.5	1 x 0.866	3/8	Enhanced	None	54
MC24B3XC1	Cooling / Heat Pump	Sweat	4.38	2	14	(2) 18 x 17.5	1 x 0.866	3/8	Enhanced	None	54
MC30A3XC1	Cooling / Heat Pump	Sweat	4.38	2	14	(2) 18 x 17.5	1 x 0.866	3/8	Enhanced	None	54
MC30B3XC1	Cooling / Heat Pump	Sweat	4.38	2	14	(2) 18 x 17.5	1 x 0.866	3/8	Enhanced	None	54
MC32A3XC1	Cooling / Heat Pump	Sweat	3.9	3	12	(2) 16 x 17.5	1 x 0.866	3/8	Enhanced	None	59
MC35B3XC1	Cooling / Heat Pump	Sweat	3.9	3	12	(2) 16 x 17.5	1 x 0.866	3/8	Enhanced	None	65
MC35C3XC1	Cooling / Heat Pump	Sweat	3.9	3	12	(2) 16 x 17.5	1 x 0.866	3/8	Enhanced	None	67
MC36A3XC1	Cooling / Heat Pump	Sweat	4.86	2	14	(2) 20 x 17.5	1 x 0.866	3/8	Enhanced	None	64
MC36B3XC1	Cooling / Heat Pump	Sweat	4.86	2	14	(2) 20 x 17.5	1 x 0.866	3/8	Enhanced	None	65
MC36C3XC1	Cooling / Heat Pump	Sweat	4.86	2	14	(2) 20 x 17.5	1 x 0.866	3/8	Enhanced	None	65
MC37A3XC1	Cooling / Heat Pump	Sweat	4.86	3	12	(2) 20 x 17.5	1 x 0.866	3/8	Enhanced	None	63
MC42B3XC1	Cooling / Heat Pump	Sweat	5.83	2	14	(2) 24 x 17.5	1 x 0.866	3/8	Enhanced	None	72
MC42C3XC1	Cooling / Heat Pump	Sweat	5.83	2	14	(2) 24 x 17.5	1 x 0.866	3/8	Enhanced	None	72
MC43B3XC1	Cooling / Heat Pump	Sweat	4.86	3	12	(2) 20 x 17.5	1 x 0.866	3/8	Enhanced	None	73
MC43C3XC1	Cooling / Heat Pump	Sweat	4.86	3	12	(2) 20 x 17.5	1 x 0.866	3/8	Enhanced	None	75
MC48C3XC1	Cooling / Heat Pump	Sweat	5.35	3	12	(2) 22 x 17.5	1 x 0.866	3/8	Enhanced	None	82
MC48D3XC1	Cooling / Heat Pump	Sweat	5.35	3	12	(2) 22 x 17.5	1 x 0.866	3/8	Enhanced	None	82
MC60D3XC1	Cooling / Heat Pump	Sweat	5.83	3	12	(2) 24 x 17.5	1 x 0.866	3/8	Enhanced	None	86
MC62D3XC1	Cooling / Heat Pump	Sweat	6.80	3	12	(2) 28 x 17.5	1 x 0.866	3/8	Enhanced	None	98

Note: MC coils supplied with a factory installed horizontal drain pan (H).

**DIMENSIONS**

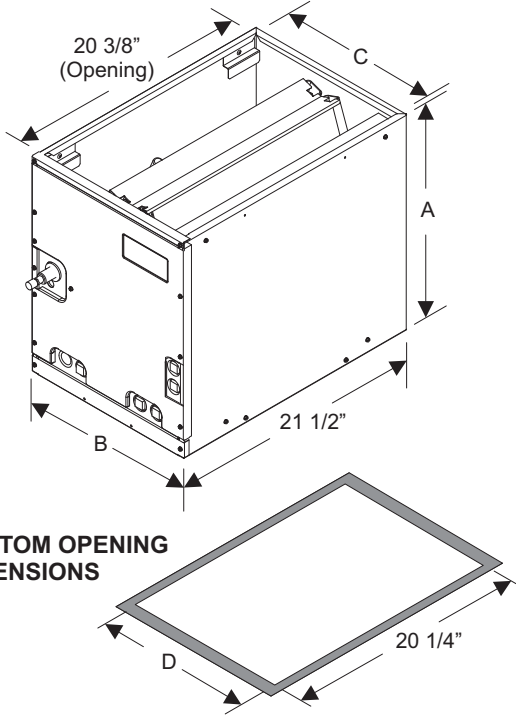

Models	Dimensions <sup>1</sup>				Refrigerant Connections <sup>2</sup>	
	Height	Width	Opening Widths		Line Size	
	A	B	C	D	Liquid	Vapor
MC18A	22	14 1/2	13 3/8	13 1/2	3/8	3/4
MC18B	22	17 1/2	16 3/8	16 1/2		
MC24A	26 1/2	14 1/2	13 3/8	13 1/2		
MC24B	26 1/2	17 1/2	16 3/8	16 1/2		
MC30A	26 1/2	14 1/2	13 3/8	13 1/2		
MC30B	26 1/2	17 1/2	16 3/8	16 1/2		
MC32A	22	14 1/2	13 3/8	13 1/2		
MC35B	22	17 1/2	16 3/8	16 1/2		
MC35C	22	21	19 7/8	20		
MC36A	26 1/2	14 1/2	13 3/8	13 1/2		
MC36B	26 1/2	17 1/2	16 3/8	16 1/2		
MC36C	26 1/2	21	19 7/8	20		
MC37A	26 1/2	14 1/2	13 3/8	13 1/2		
MC42B	32	17 1/2	16 3/8	16 1/2		
MC42C	32	21	19 7/8	20		
MC43B	26 1/2	17 1/2	16 3/8	16 1/2		
MC43C	26 1/2	21	19 7/8	20		
MC48C	32	21	19 7/8	20		
MC48D	32	24 1/2	23 3/8	23 1/2		
MC60D	32	24 1/2	23 3/8	23 1/2		
MC62D	36	24 1/2	23 3/8	23 1/2		
					7/8	

1 All dimensions are in inches.

2 Refrigerant line sizes may require larger lines for extended line lengths. See Application Data part number 247077.

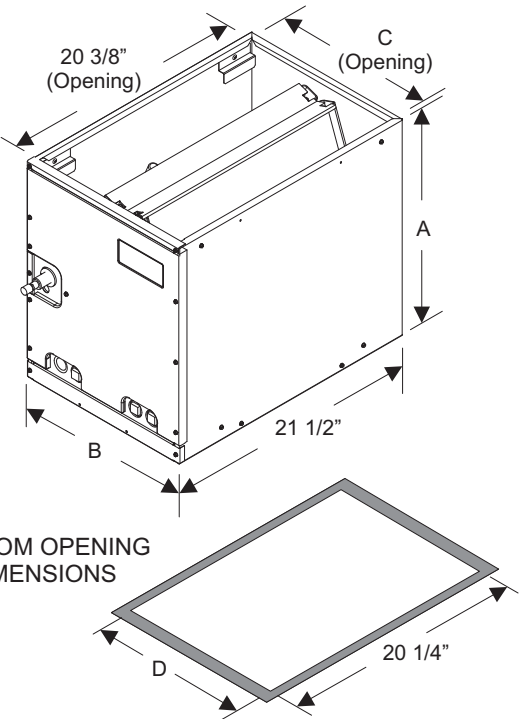

Models	Dimensions <sup>1</sup>				Refrigerant Connections <sup>2</sup>	
	Height	Width	Opening Widths		Line Size	
	A	B	C	D	Liquid	Vapor
FC18A	18	14 1/2	13 3/8	13 1/2	3/8	3/4
FC18B	18	17 1/2	16 3/8	16 1/2		
FC24A	22	14 1/2	13 3/8	13 1/2		
FC24B	22	17 1/2	16 3/8	16 1/2		
FC30A	22	14 1/2	13 3/8	13 1/2		
FC30B	22	17 1/2	16 3/8	16 1/2		
FC32A	20	14 1/2	13 3/8	13 1/2		
FC35B	20	17 1/2	16 3/8	16 1/2		
FC35C	24 1/2	21	19 7/8	20		
FC36A	24 1/2	14 1/2	13 3/8	13 1/2		
FC36B	24 1/2	17 1/2	16 3/8	16 1/2		
FC36C	24 1/2	21	19 7/8	20		
FC37A	24 1/2	14 1/2	13 3/8	13 1/2		
FC42B	28	17 1/2	16 3/8	16 1/2		
FC42C	28	21	19 7/8	20		
FC43B	24 1/2	17 1/2	16 3/8	16 1/2		
FC43C	24 1/2	21	19 7/8	20		
FC48C	28	21	19 7/8	20		
FC48D	28	24 1/2	23 3/8	23 1/2		
FC60C	28	21	19 7/8	20		
FC60D	28	24 1/2	23 3/8	23 1/2		
FC62D	32	24 1/2	23 3/8	23 1/2		
FC64D	36	24 1/2	23 3/8	23 1/2		
					7/8	

1 All dimensions are in inches.

2 Refrigerant line sizes may require larger lines for extended line lengths. See Application Data part number 247077.

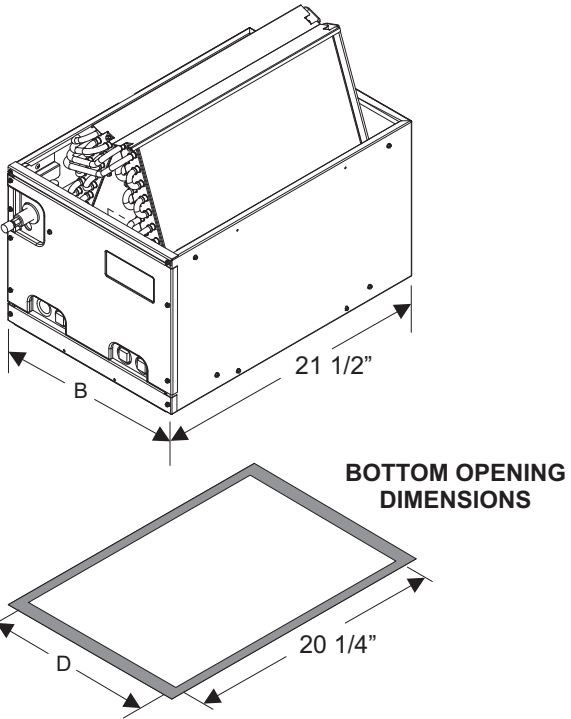
	Models	Dimensions <sup>1</sup>				Refrigerant Connections <sup>2</sup>	
		Height	Width	Opening Widths		Line Size	
		A	B	C	D	Liquid	Vapor
	PC18A	17 3/4	14 1/2	13 3/8	13 1/2	3/8	3/4
	PC18B	17	17 1/2	16 3/8	16 1/2		
	PC24A	21 7/8	14 1/2	13 3/8	13 1/2		
	PC24B	21 3/8	17 1/2	16 3/8	16 1/2		
	PC30A	21 7/8	14 1/2	13 3/8	13 1/2		
	PC30B	21 3/8	17 1/2	16 3/8	16 1/2		
	PC32A	20	14 1/2	13 3/8	13 1/2		
	PC35B	18 7/8	17 1/2	16 3/8	16 1/2		
	PC35C	18 3/4	21	19 7/8	20		
	PC36A	23 7/8	14 1/2	13 3/8	13 1/2		7/8
	PC36B	23 1/8	17 1/2	16 3/8	16 1/2		
	PC36C	22 7/8	21	19 7/8	20		
	PC37A	23 7/8	14 1/2	13 3/8	13 1/2		3/4
	PC42B	27 5/8	17 1/2	16 3/8	16 1/2		
	PC42C	27 1/8	21	19 7/8	20		7/8
	PC43B	23 1/8	17 1/2	16 3/8	16 1/2		
	PC43C	22 5/8	21	19 7/8	20		
	PC48C	25 3/8	21	19 7/8	20		
	PC48D	24 5/8	24 1/2	23 3/8	23 1/2		
	PC60C	27 1/2	21	19 7/8	20		
	PC60D	26 7/8	24 1/2	23 3/8	23 1/2		

- 1 All dimensions are in inches.
- 2 Refrigerant line sizes may require larger lines for extended line lengths. See Application Data part number 247077.

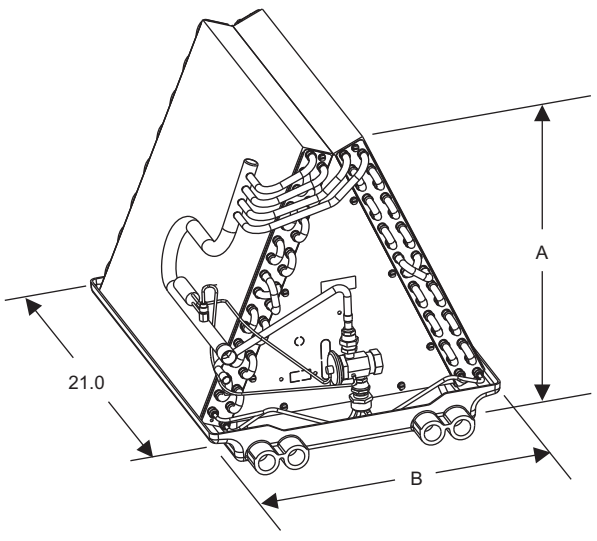
	Models	Dimensions <sup>1</sup>		Refrigerant Connections <sup>2</sup>	
		Height	Width	Line Size	
		A	B	Liquid	Vapor
	UC18A	17	13	3/8	3/4
	UC18B	16 1/2	16		
	UC24A	21	13		
	UC24B	20 1/2	16		
	UC30A	21	13		7/8
	UC30B	20 1/2	16		
	UC36A	23 1/2	13		
	UC36B	22 1/2	16		
	UC36C	22	19 1/2		
	UC42B	26 1/2	16		
	UC42C	25 1/2	19 1/2		
	UC48C	23 1/2	19 1/2		
	UC48D	23	23		
	UC60C	25 1/2	19 1/2		
	UC60D	25	23		

- 1 All dimensions are in inches.
- 2 Refrigerant line sizes may require larger lines for extended line lengths. See Application Data part number 247077.

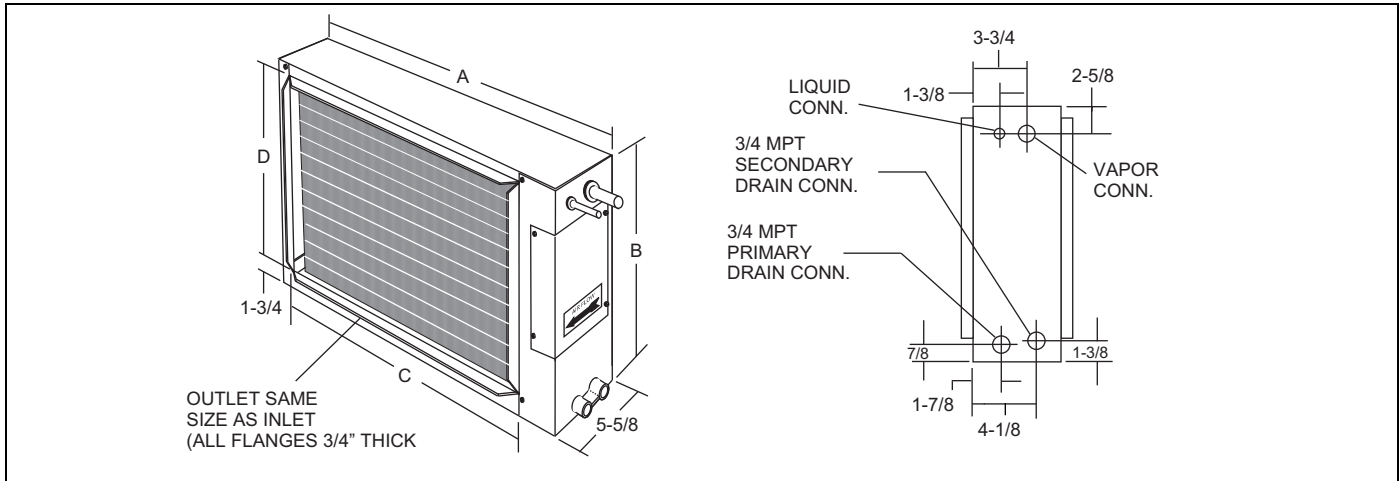

**COIL - HD**

**DIMENSIONS - HD Coils**

Models	Dimensions <sup>1</sup>				Refrigerant Connections <sup>2</sup>	
	Height	Width	Opening Widths		Line Size	
	A	B	C	D	Liquid	Vapor
HD24S	24	28 3/4	23 3/4	21 5/8	3/8	3/4
HD36S	28	28 3/4	23 3/4	25 5/8		7/8
HD48S	28	34 3/4	29 3/4	25 5/8		
HD60S	30	34 3/4	29 3/4	27 5/8		

1 All dimensions are in inches.

2 Refrigerant line sizes may require larger lines for extended line lengths. See Application Data part number 247077.