

# GAS SERIES

## UNCASED CEILING MOUNT ELECTRIC HEAT DX COOL AIR HANDLER

### Product Dimensions & Specifications



#### WARRANTY

One year limited parts warranty

#### OPTIONS

See options menu

#### MANUFACTURED IN THE USA

#### STANDARD FEATURES

##### APPLICATION VERSATILITY

Built in mounting tabs for ceiling or furrdown mounting. Louvered ceiling access panel has separate frame that attaches to ceiling joists. Solid access panel available for use with end return installations. Compatible with most brands of air conditioners or heat pumps.

##### MOTOR

Direct drive multi-speed blowers circulate air quietly and efficiently. Two speed motors allow for precise air volume selection. Motor speeds can be easily selected via motor terminals. Blowers mounted on plate so they can be easily removed for service.

##### ELECTRIC HEAT KITS

Heat kits available in 3, 5, 6, 8, & 10 KW. Models with electric heat include sequencers and temperature limit switches for safe, efficient operation. Easily accessible controls for quick service.

##### ELECTRONIC CIRCUIT BOARD

Electronic circuit board provides 30 secs ON/OFF blower time delay extracting more heat/cool from the coil. Automotive-style pull fuse protection on the circuit board to provide low voltage and transformer protection.

##### DX COIL

High efficiency rifled copper tubes/enhanced aluminum fins provide maximum heat transfer. All coils immersion tested at 500 psi then nitrogen pressurized and factory sealed for maximum reliability. Liquid-line Schrader allows pre-installation pressure testing. Available with either orifice or TXV metering device factory installed. Field-installable bolt-on TXVs are also available. Primary & secondary condensate drain. All drain connections are 3/4" MPT. Powder-painted metal drain pan. Access door allows for coil cleaning. Certified for use with either R22 or R410A.

##### LOW LEAKAGE

Less than 2% air leakage from cabinet when installed in enclosure and tested in accordance with ASHRAE 193. Unit must be installed in accordance with AirMark installation instructions. Sturdy, fully insulated galvanized enclosure with ducted return available as option.

Representative image only.

Some models may vary in appearance.

Due to continuous product improvement, specifications are subject to change without notice.



Rev. Date: 03/03/22

© 2022 AirMark



## HEATING AND COOLING PERFORMANCE AND ELECTRICAL DATA

MODEL	HEAT KIT	PERFORMANCE DATA				ELECTRICAL DATA				
		NOMINAL COOLING (BTUS)	HEATING KW		HEATING KBTUH		MINIMUM CIRCUIT AMPACITY (MCA)		MAX BREAKER OR FUSE SIZE	
			208V	240V	208V	240V	208V	240V	208V	240V
GAS 18/19/20	HTS00	18,000	0.0	0.0	0.0	0.0	1.8	1.8	15.0	15.0
	HTS03		2.3	3.0	7.8	10.2	15.3	17.4	20.0	20.0
	HTS05		3.7	4.8	12.6	16.4	23.4	26.8	25.0	30.0
	HTS06		4.6	6.0	15.7	20.5	28.8	33.0	30.0	35.0
	HTS08		6.1	8.0	20.8	27.3	37.8	43.4	40.0	45.0
	HTS10		7.4	9.6	25.3	32.8	45.0	51.8	45.0	60.0
GAS 24/25	HTS00	24,000	0.0	0.0	0.0	0.0	1.8	1.8	15.0	15.0
	HTS03		2.3	3.0	7.8	10.2	15.3	17.4	20.0	20.0
	HTS05		3.7	4.8	12.6	16.4	23.4	26.8	25.0	30.0
	HTS06		4.6	6.0	15.7	20.5	28.8	33.0	30.0	35.0
	HTS08		6.1	8.0	20.8	27.3	37.8	43.4	40.0	45.0
	HTS10		7.4	9.6	25.3	32.8	45.0	51.8	45.0	60.0
GAS 26/28	HTS00	24,000	0.0	0.0	0.0	0.0	2.7	2.7	15.0	15.0
	HTS03		2.3	3.0	7.8	10.2	16.2	18.3	20.0	20.0
	HTS05		3.7	4.8	12.6	16.4	24.3	27.7	25.0	30.0
	HTS06		4.6	6.0	15.7	20.5	29.7	33.9	30.0	35.0
	HTS08		6.1	8.0	20.8	27.3	38.8	44.4	40.0	45.0
	HTS10		7.4	9.6	25.3	32.8	46.0	52.7	50.0	60.0
GAS 30/31/32	HTS00	30,000	0.0	0.0	0.0	0.0	2.7	2.7	15.0	15.0
	HTS03		2.3	3.0	7.8	10.2	16.2	18.3	20.0	20.0
	HTS05		3.7	4.8	12.6	16.4	24.3	27.7	25.0	30.0
	HTS06		4.6	6.0	15.7	20.5	29.7	33.9	30.0	35.0
	HTS08		6.1	8.0	20.8	27.3	38.8	44.4	40.0	45.0
	HTS10		7.4	9.6	25.3	32.8	46.0	52.7	50.0	60.0
GAS 36/37	HTS00	36,000	0.0	0.0	0.0	0.0	2.7	2.7	15.0	15.0
	HTS03		2.3	3.0	7.8	10.2	16.2	18.3	20.0	20.0
	HTS05		3.7	4.8	12.6	16.4	24.3	27.7	25.0	30.0
	HTS06		4.6	6.0	15.7	20.5	29.7	33.9	30.0	35.0
	HTS08		6.1	8.0	20.8	27.3	38.8	44.4	40.0	45.0
	HTS10		7.4	9.6	25.3	32.8	46.0	52.7	50.0	60.0

## BLOWER DATA

UNIT MODEL	SPEED TAP	MOTOR HP	CFM VS. STATIC PRESSURE							
			0.05	0.1	0.15	0.2	0.25	0.3	0.35	0.4
GAS 18/19/24	HIGH	1/4	880	800	770	740	705	670	640	610
	LOW		732	711	690	645	620	600	570	543
GAS 20/25	HIGH	1/4	990	960	910	870	815	760	730	690
	LOW		820	790	765	732	690	650	610	595
GAS 26	HIGH	1/3	1040	1008	956	914	856	798	767	725
	LOW		861	830	803	769	725	683	640	625
GAS 28	HIGH	1/3	1040	1008	956	914	856	798	767	725
	LOW		861	830	803	769	725	683	641	625
GAS 30	HIGH	1/3	1085	1045	1000	950	900	850	800	740
	LOW		965	925	880	850	800	750	700	650
GAS 31	HIGH	1/3	1230	1150	1110	1070	1020	980	940	890
	LOW		1057	1010	980	940	910	870	830	775
GAS 32	HIGH	1/3	1350	1325	1285	1225	1190	1140	1090	1050
	LOW		1040	1030	1010	990	960	940	900	850
GAS 36/37	HIGH	1/3	1350	1325	1285	1225	1190	1140	1090	1050
	LOW		1040	1030	1010	990	960	940	900	850

Note: Units should not be applied to a system with less than 350 CFM/Ton airflow. Add 0.05 static when enclosure and/or ceiling panel are used.

## AIR HANDLER CHASSIS NOMENCLATURE

G	A	S	18	G	-001
AirMark Air Handler	<u>Voltage</u> A = 240V PSC Motor	<u>Configuration</u> S = Uncased Ceiling Mount	Nominal Tonnage (KBTUH)	<u>Metering Device</u> 4 = R410A non-bleed A/C or H/P TXV 6 = R410A 20% bleed A/C or H/P TXV B = R22 20% bleed A/C or H/P TXV F = R22 Flo-rater G = R410A Flo-rater X = R22 non-bleed A/C or H/P TXV	Option Code

## ELECTRIC HEAT KIT NOMENCLATURE

H	T	S	10
H = Fits GAS, GAT, GES, GET	T = Terminal Block	S = Small Cabinet (18 - 37)	<u>Heat Strip</u> 00 = NO Heat 03 = 3 KW 05 = 5 KW 06 = 6 KW 08 = 8 KW 10 = 10 KW

## ENCLOSURES DIMENSIONS

UNIT MODEL	A"	B"	C"	Weight (lbs)	Skid Qty.
GAS 18/19/24	37 1/4	34-5/8	30	85	8
GAS 20/25/30	43 1/4	40-5/8	36	90	8
GAS 26/31/36	49 1/4	46 5/8	42	95	8
GAS 28/32/37	56 1/4	53 5/8	48	110	8

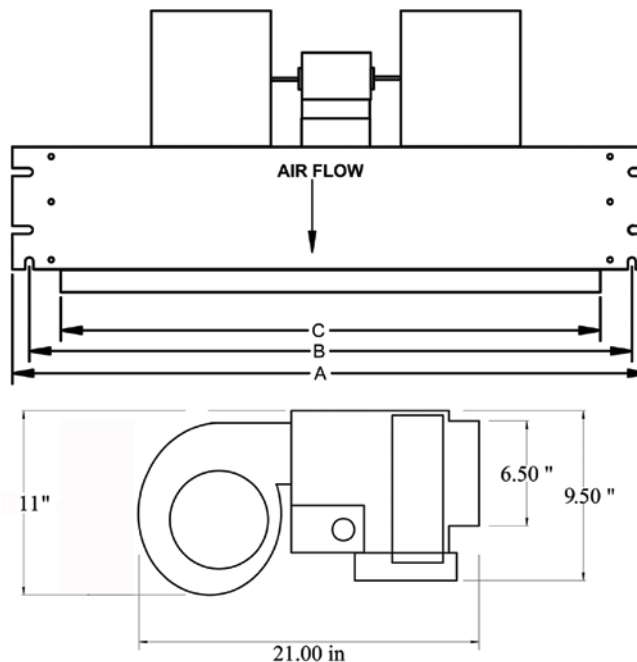

Copper stub out diameter: Suction: 3/4", Liquid: 3/8"

# Access Door

## VERSATILITY

Equipped with hidden frame feature. Fastens to the outside wall surface and does not have to perfectly match the hole opening. Frame screws are not visible after installation. Available in either solid (S) or louvered (L) style.

## MATERIALS

Galvanized steel construction with smooth powder paint finish.

## FILTER

20" x 20" x 1" field supplied.

## WARRANTY

One-year limited parts warranty.

ACCESS DOOR DIMENSIONS						
FOR USE WITH	PANEL MODEL	GAS ACCESS DOOR AND FRAME				FILTERS (QTY)
		A"	B"	C"	D"	
GAS 18/19/24	GAD-1(S/L)	43-1/2	27-1/2	41-1/2	26	1
GAS 20/25/30	GAD-5(S/L)	49-1/2	27-1/2	47-1/2	26	2
GAS 26/31/36	GAD-2(S/L)	55-1/2	27-1/2	53-1/2	26	2
GAS 28/32/37	GAD-6(S/L)	63-1/2	27-1/2	61-1/2	26	2

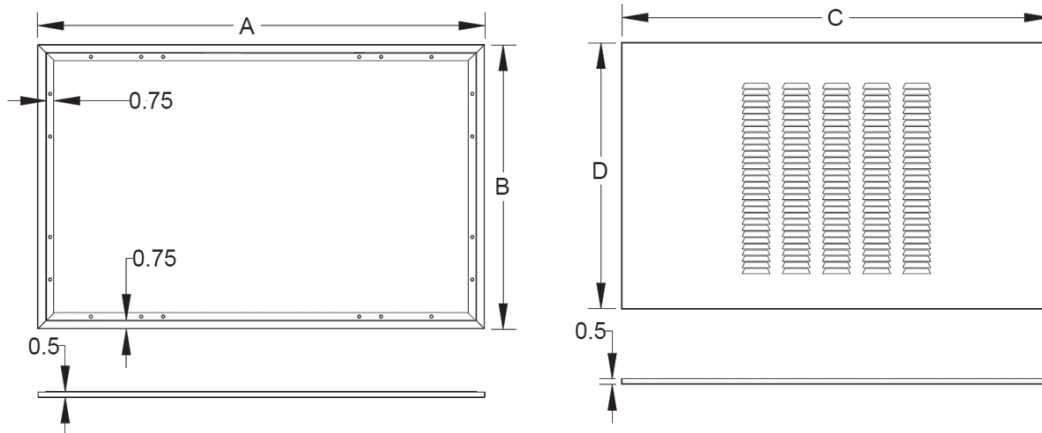

**⚠ WARNING**  
**Cancer and**  
**Reproductive Harm**  
[www.P65Warnings.ca.gov](http://www.P65Warnings.ca.gov)



373 Atascocita Rd  
 Humble, TX 77396  
 Phone 800.423.9007  
 Fax 281.441.6510  
[www.airmark-ac.com](http://www.airmark-ac.com)