

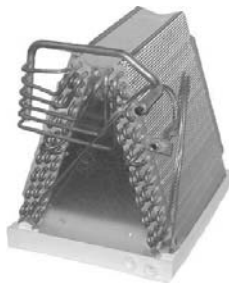

Air Conditioning & Heating

## PRODUCT SPECIFICATIONS



CAUF Uncased



CAPF Cased



CHPF Horizontal "A"

CSCF Horizontal Slab



### CASED, PAINTED UPFLOW/ DOWNFLOW, UNCASED UPFLOW/ DOWNFLOW, HORIZONTAL "A" & HORIZONTAL SLAB INDOOR COILS

## DUAL-REFRIGERANT COILS

### CAPF, CAUF, CHPF, & CSCF

Goodman® brand coils are designed for use with Goodman brand gas furnaces, split system air conditioners and heat pumps, as well as modular, two-piece blowers. Each cased coil has a quality, galvanized-steel cabinet.

#### Standard Features

- Suitable for use with R-410A and R-22 refrigerants
- Rust-resistant, thermoplastic drain pans feature a low water-retention design
- Check flowrate expansion device for heat pump or cooling-only applications
- Rifled copper tubing and louvered aluminum fin coils on CAPF, CAUF, and CSCF coils
- Rifled aluminum tubing and louvered aluminum fin coils on the CHPF coil

#### Cased Coil Cabinet Features

- Foil-face insulation
- Galvanized leather-grain finish
- Architectural Gray paint finish on CAPF and CHPF cased coils
- Split-seam front for easy access
- 17½", 21", and 24½" CHPF coils have one 3½" adapter plate
- 17½", 21", and 24½" CAPF coils have two 1¾" adapter plates

**Note:** Do not use these coils on oil furnaces or any applications where the temperature on the drain pan may exceed 300°F. If these coils are applied with an oil furnace or another application where high temperatures threaten or jeopardize the durability of the drain pan, you must replace the factory-installed drain pan with a high-temperature drain pan. High-temperature drain pan kits are available as field-installed accessories.



\* To receive the 10-Year Parts Limited Warranty, online registration must be completed within 60 days of installation. Online registration is not required in California or Québec. Full warranty details available at [www.goodmanmfg.com](http://www.goodmanmfg.com).



## NOMENCLATURE

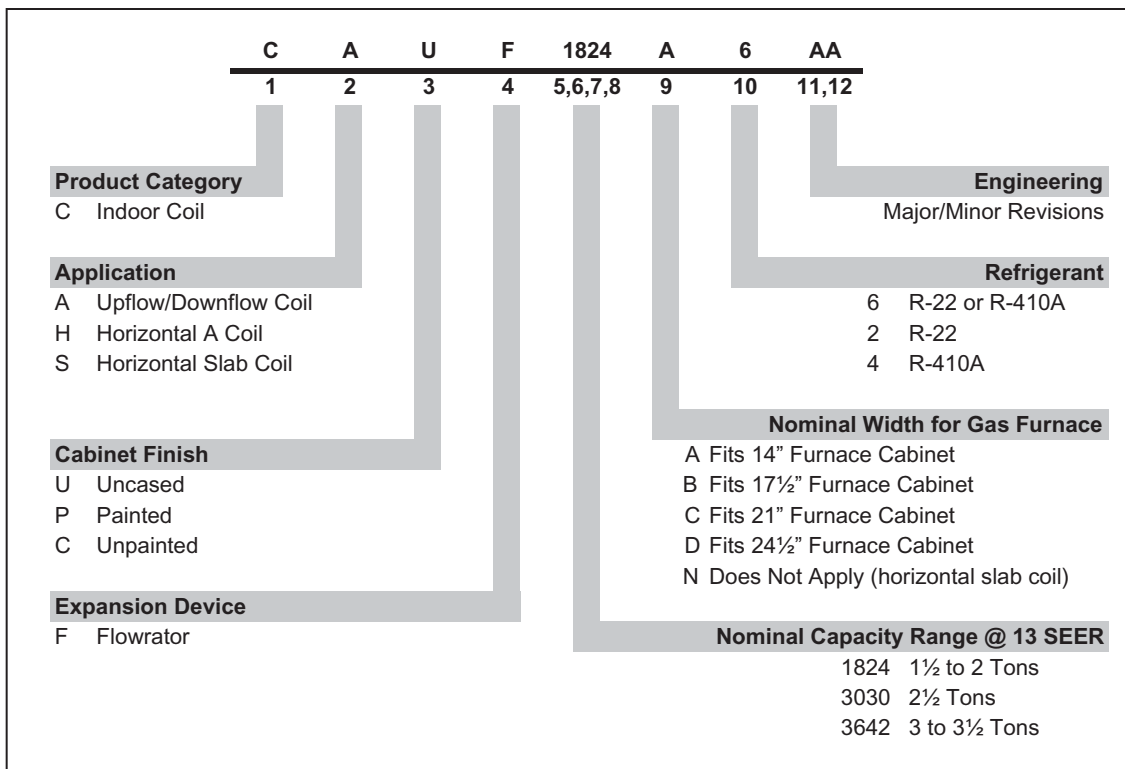

## ACCESSORIES

### EXPANSION VALVE KITS

Kit Number	Description	Application	Refrigerant	Tonnage: Outdoor Unit
XVB18-36C	20% Bleed Valve	AC Only	R-22	1½ - 3 Ton
XVB42-60C	20% Bleed Valve	AC Only	R-22	3½ - 5 Ton
XV18-36C	Non-bleed Valve	AC Only	R-22	1½ - 3 Ton
XV42-60C	Non-bleed Valve	AC Only	R-22	3½ - 5 Ton
TX2N2	Non-bleed Valve	AC or HP	R-22	1½ - 2 Ton
TX3N2	Non-bleed Valve	AC or HP	R-22	2½ - 3 Ton
TX5N2	Non-bleed Valve	AC or HP	R-22	3½ - 5 Ton
TX2N4	Non-bleed Valve	AC or HP	R-410A	1½ - 2 Ton
TX3N4	Non-bleed Valve	AC or HP	R-410A	2½ - 3 Ton
TX5N4	Non-bleed Valve	AC or HP	R-410A	3½ - 5 Ton

**Note:** Condensing units and heat pumps with reciprocating compressors require the use of start-assist components when used in conjunction with an indoor coil using a non-bleed thermal expansion valve refrigerant metering device.

### DRAIN PAN KITS

Drain Pan Kits	Furnace Size
HTP-A	14" furnaces
HTP-B	17½" furnaces
HTP-C	21" furnaces
HTP-D	24½" furnaces

# CAUF — UNCASD UPFLOW/DOWNFLOW INDOOR COILS

## SPECIFICATIONS

Model	Dimensions				Nominal Tons	Coil Dimensions		Connection		Ship Weight (lbs)
	W	D	H	A		W	H	Liquid	Suction	
CAUF1824A6	13"	20½"	18⅝"	13"	1½-2	16¾"	14"	⅜"	¾"	20
CAUF1824B6	16½"	20½"	20"	13"	1½-2	16¾"	16"	⅜"	¾"	23
CAUF1824C6	20"	20½"	17⅝"	17"	1½-2	16¾"	14"	⅜"	¾"	27
CAUF3030A6	13"	20½"	20"	17"	2½	16¾"	16"	⅜"	¾"	23
CAUF3030B6	16½"	20½"	20"	17"	2½	16¾"	16"	⅜"	¾"	26
CAUF3030C6	20"	20½"	18⅝"	17"	2½	16¾"	16"	⅜"	¾"	29
CAUF3030D6	23"	20½"	17¾"	17"	2½	16¾"	16"	⅜"	¾"	32
CAUF3131B6	16½"	20½"	19 <sup>15</sup> / <sub>16</sub> "	17"	2½	16¾"	18"	⅜"	¾"	28
CAUF3131C6	20"	20½"	24 <sup>7</sup> / <sub>8</sub> "	17"	2½	16¾"	20"	⅜"	7 <sup>7</sup> / <sub>8</sub> "	31
CAUF3636A6	13"	20½"	19 <sup>9</sup> / <sub>16</sub> "	17"	3	16¾"	16"	⅜"	7 <sup>7</sup> / <sub>8</sub> "	23
CAUF3636B6	16½"	20½"	19 <sup>3</sup> / <sub>8</sub> "	17"	3	16¾"	16"	⅜"	7 <sup>7</sup> / <sub>8</sub> "	29
CAUF3636C6	20"	20½"	19 <sup>1</sup> / <sub>8</sub> "	17"	3	16¾"	16"	⅜"	7 <sup>7</sup> / <sub>8</sub> "	33
CAUF3636D6	23"	20½"	19 <sup>1</sup> / <sub>8</sub> "	17"	3	16¾"	16"	⅜"	7 <sup>7</sup> / <sub>8</sub> "	36
CAUF3642C6	20"	20½"	19 <sup>15</sup> / <sub>16</sub> "	17"	3-3½	16¾"	18"	⅜"	7 <sup>7</sup> / <sub>8</sub> "	33
CAUF3642D6	23"	20½"	19 <sup>7</sup> / <sub>8</sub> "	17"	3-3½	16¾"	18"	⅜"	7 <sup>7</sup> / <sub>8</sub> "	34
CAUF3743C6	20"	20½"	28 <sup>5</sup> / <sub>16</sub> "	25"	3-3½	16¾"	26"	⅜"	7 <sup>7</sup> / <sub>8</sub> "	46
CAUF3743D6	23"	20½"	28 <sup>5</sup> / <sub>8</sub> "	25"	3-3½	16¾"	26"	⅜"	7 <sup>7</sup> / <sub>8</sub> "	49
CAUF4860C6	20"	20½"	28 <sup>5</sup> / <sub>16</sub> "	25"	4-5	16¾"	26"	⅜"	7 <sup>7</sup> / <sub>8</sub> "	48
CAUF4860D6	23"	20½"	28 <sup>1</sup> / <sub>8</sub> "	25"	4-5	16¾"	26"	⅜"	7 <sup>7</sup> / <sub>8</sub> "	51
CAUF4961C6	20"	20½"	28 <sup>5</sup> / <sub>16</sub> "	25"	4-5	16¾"	26"	⅜"	7 <sup>7</sup> / <sub>8</sub> "	54
CAUF4961D6	23"	20½"	28 <sup>1</sup> / <sub>8</sub> "	25"	4-5	16¾"	26"	⅜"	7 <sup>7</sup> / <sub>8</sub> "	58

Note: For a properly matched system, refer to specification sheet of the corresponding Goodman® outdoor unit.

## DIMENSIONS

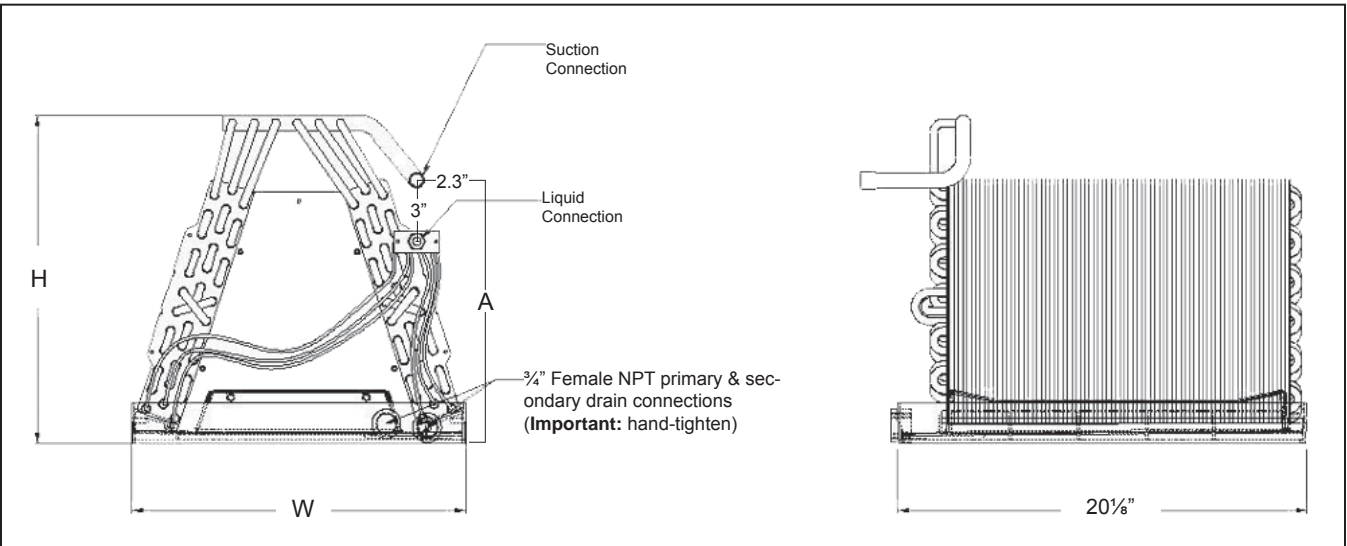

# PRODUCT SPECIFICATIONS

## CAPF — CASED UPFLOW/DOWNFLOW INDOOR COILS

### SPECIFICATIONS

Model	Dimensions			Plenum Opening		Evap Coil Face Area*	Coil Dimensions		Nominal Tons	Connection		Ship Weight (lbs)
	W	D	H	W	H		W	H		Liquid	Suction	
CAPF1824A6	14"	21"	18"	13"	17"	3 <sup>3</sup> / <sub>4</sub>	16 <sup>3</sup> / <sub>4</sub> "	14"	1½-2	3 <sup>3</sup> / <sub>8</sub> "	3 <sup>3</sup> / <sub>4</sub> "	35
CAPF1824B6	17½"	21"	18"	16½"	17"	3 <sup>5</sup> / <sub>7</sub>	16 <sup>3</sup> / <sub>4</sub> "	16"	1½-2	3 <sup>3</sup> / <sub>8</sub> "	3 <sup>3</sup> / <sub>4</sub> "	40
CAPF1824C6	21"	21"	22"	20"	21"	3 <sup>3</sup> / <sub>4</sub>	16 <sup>3</sup> / <sub>4</sub> "	14"	1½-2	3 <sup>3</sup> / <sub>8</sub> "	3 <sup>3</sup> / <sub>4</sub> "	44
CAPF3030A6	14"	21"	22"	13"	21"	3 <sup>3</sup> / <sub>4</sub>	16 <sup>3</sup> / <sub>4</sub> "	16"	2½	3 <sup>3</sup> / <sub>8</sub> "	3 <sup>3</sup> / <sub>4</sub> "	39
CAPF3030B6	17½"	21"	22"	16½"	21"	3 <sup>3</sup> / <sub>4</sub>	16 <sup>3</sup> / <sub>4</sub> "	16"	2½	3 <sup>3</sup> / <sub>8</sub> "	3 <sup>3</sup> / <sub>4</sub> "	43
CAPF3030C6	21"	21"	22"	20"	21"	3 <sup>3</sup> / <sub>4</sub>	16 <sup>3</sup> / <sub>4</sub> "	16"	2½	3 <sup>3</sup> / <sub>8</sub> "	3 <sup>3</sup> / <sub>4</sub> "	47
CAPF3030D6	24½"	21"	22"	23½"	21"	3 <sup>3</sup> / <sub>4</sub>	16 <sup>3</sup> / <sub>4</sub> "	16"	2½	3 <sup>3</sup> / <sub>8</sub> "	3 <sup>3</sup> / <sub>4</sub> "	52
CAPF3131B6	17½"	21"	22"	16½"	21"	4 <sup>1</sup> / <sub>5</sub>	16 <sup>3</sup> / <sub>4</sub> "	18"	2½	3 <sup>3</sup> / <sub>8</sub> "	3 <sup>3</sup> / <sub>4</sub> "	45
CAPF3131C6	21"	21"	26"	20"	25"	4 <sup>2</sup> / <sub>3</sub>	16 <sup>3</sup> / <sub>4</sub> "	20"	2½	3 <sup>3</sup> / <sub>8</sub> "	7 <sup>7</sup> / <sub>8</sub> "	50
CAPF3636A6	14"	21"	22"	13"	21"	3 <sup>3</sup> / <sub>4</sub>	16 <sup>3</sup> / <sub>4</sub> "	16"	3	3 <sup>3</sup> / <sub>8</sub> "	7 <sup>7</sup> / <sub>8</sub> "	39
CAPF3636B6	17½"	21"	22"	16½"	21"	3 <sup>3</sup> / <sub>4</sub>	16 <sup>3</sup> / <sub>4</sub> "	16"	3	3 <sup>3</sup> / <sub>8</sub> "	7 <sup>7</sup> / <sub>8</sub> "	47
CAPF3636C6	21"	21"	22"	20"	21"	3 <sup>3</sup> / <sub>4</sub>	16 <sup>3</sup> / <sub>4</sub> "	16"	3	3 <sup>3</sup> / <sub>8</sub> "	7 <sup>7</sup> / <sub>8</sub> "	53
CAPF3636D6	24½"	21"	22"	23½"	21"	3 <sup>3</sup> / <sub>4</sub>	16 <sup>3</sup> / <sub>4</sub> "	16"	3	3 <sup>3</sup> / <sub>8</sub> "	7 <sup>7</sup> / <sub>8</sub> "	56
CAPF3642C6	21"	21"	22"	20"	21"	4 <sup>1</sup> / <sub>5</sub>	16 <sup>3</sup> / <sub>4</sub> "	18"	3-3½	3 <sup>3</sup> / <sub>8</sub> "	7 <sup>7</sup> / <sub>8</sub> "	59
CAPF3642D6	24½"	21"	22"	23½"	21"	4 <sup>1</sup> / <sub>5</sub>	16 <sup>3</sup> / <sub>4</sub> "	18"	3-3½	3 <sup>3</sup> / <sub>8</sub> "	7 <sup>7</sup> / <sub>8</sub> "	62
CAPF3743C6	21"	21"	30"	20"	29"	6	16 <sup>3</sup> / <sub>4</sub> "	26"	3-3½	3 <sup>3</sup> / <sub>8</sub> "	7 <sup>7</sup> / <sub>8</sub> "	71
CAPF3743D6	24½"	21"	30"	23½"	29"	6	16 <sup>3</sup> / <sub>4</sub> "	26"	3-3½	3 <sup>3</sup> / <sub>8</sub> "	7 <sup>7</sup> / <sub>8</sub> "	78
CAPF4860C6	21"	21"	30"	20"	29"	6	16 <sup>3</sup> / <sub>4</sub> "	26"	4-5	3 <sup>3</sup> / <sub>8</sub> "	7 <sup>7</sup> / <sub>8</sub> "	73
CAPF4860D6	24½"	21"	30"	23½"	29"	6	16 <sup>3</sup> / <sub>4</sub> "	26"	4-5	3 <sup>3</sup> / <sub>8</sub> "	7 <sup>7</sup> / <sub>8</sub> "	80
CAPF4961C6	21"	21"	30"	20"	29"	6	16 <sup>3</sup> / <sub>4</sub> "	26"	4-5	3 <sup>3</sup> / <sub>8</sub> "	7 <sup>7</sup> / <sub>8</sub> "	80
CAPF4961D6	24½"	21"	30"	23½"	29"	6	16 <sup>3</sup> / <sub>4</sub> "	26"	4-5	3 <sup>3</sup> / <sub>8</sub> "	7 <sup>7</sup> / <sub>8</sub> "	87

\* (ft<sup>2</sup>)

### DIMENSIONS

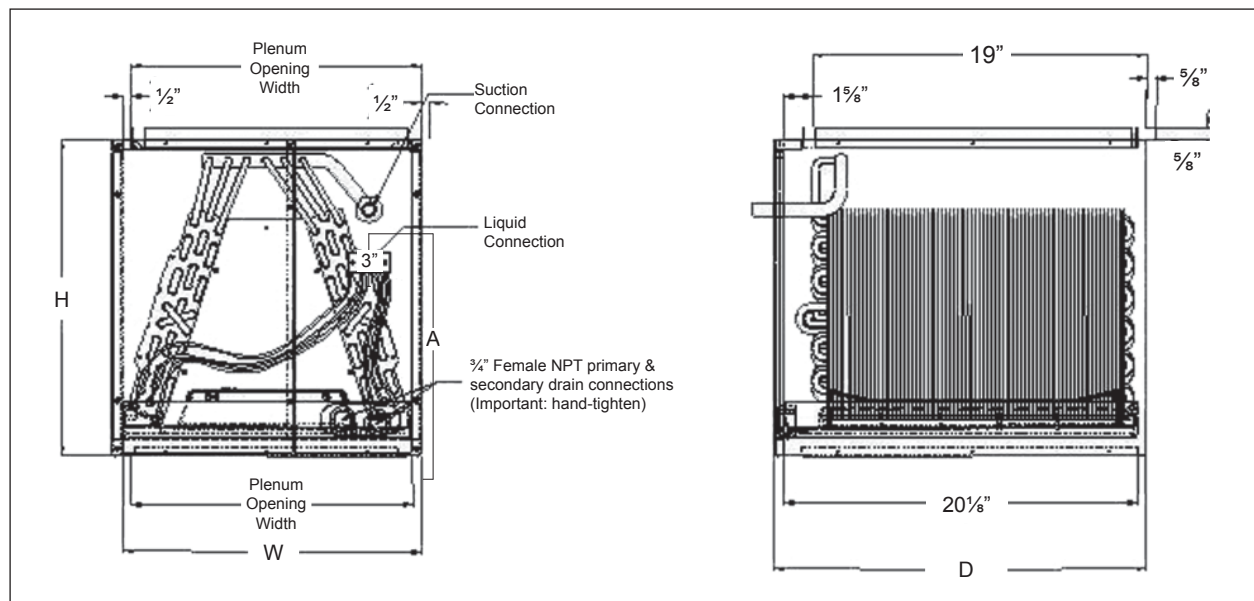

# CHPF — CASED HORIZONTAL “A” INDOOR COIL

## SPECIFICATIONS

Model	Cabinet Dimensions			Plenum Opening		Nominal Tons	Evap Coil Face Area*	Coil Dimensions		Connection		Ship Weight (lbs)
	W	D	H	W	H			W	H	Liquid	Suction	
CHPF1824A6	21 1/8"	26"	14"	19"	13"	1 1/2-2	3 1/3	20 1/8"	12"	3/8"	3/4"	36
CHPF2430B6	21 1/8"	26"	17 1/2"	19"	16 1/2"	2-2 1/2	4 1/2	20 1/8"	16"	3/8"	3/4"	55
CHPF3636B6	21 1/8"	26"	17 1/2"	19"	16 1/2"	3	4 1/3	19 1/2"	16"	3/8"	7/8"	50
CHPF3642C6	21 1/8"	26"	21"	19"	20"	3-3 1/2	4 1/3	19 1/2"	16"	3/8"	7/8"	63
CHPF3642D6	21 1/8"	26"	24 1/2"	19"	23 1/2"	3-3 1/2	6	19 1/2"	22"	3/8"	7/8"	66
CHPF3743C6	21 1/8"	26"	21"	19"	20"	3-3 1/2	4 1/3	19 1/2"	16"	3/8"	7/8"	63
CHPF3743D6	21 1/8"	26"	24 1/2"	19"	23 1/2"	3-3 1/2	6	19 1/2"	22"	3/8"	7/8"	63
CHPF4860D6	21 1/8"	26"	24 1/2"	19"	23 1/2"	4-5	6	19 1/2"	22"	3/8"	7/8"	77

\* (ft<sup>2</sup>)

## DIMENSIONS

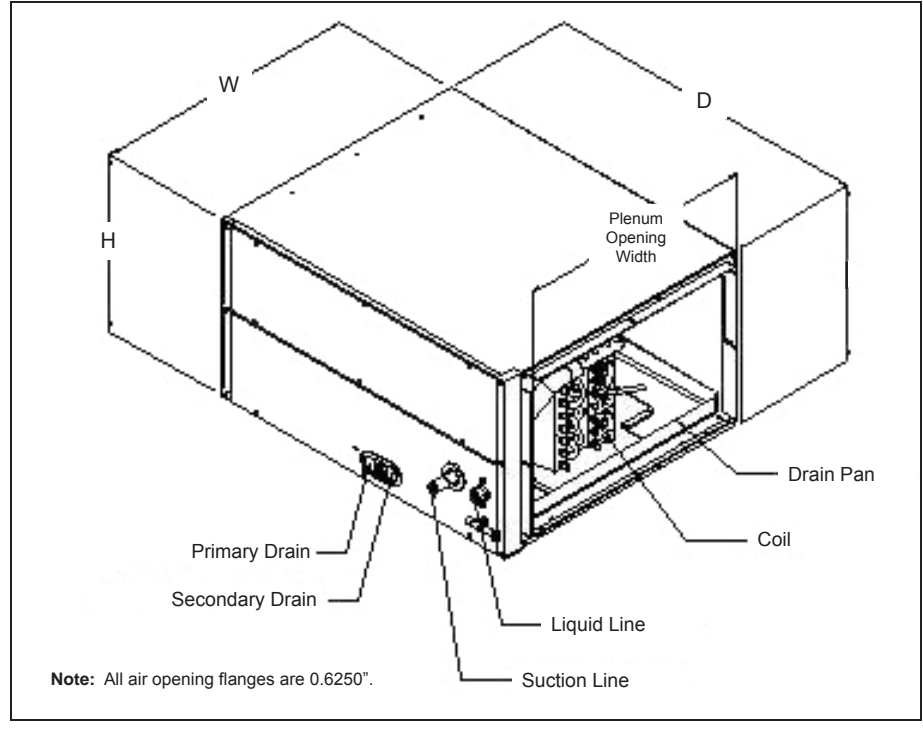

# PRODUCT SPECIFICATIONS

## CSCF — HORIZONTAL SLAB EVAPORATOR COILS

### SPECIFICATIONS

Model	Nominal Tons	Evap Coil Face Area*	Connection		Ship Weight (lbs)
			Liquid	Suction	
CSCF1824N6	1½-2	3⅓	⅜"	¼"	42
CSCF3036N6	2½-3	4⅔	⅜"	⅞"	53
CSCF3642N6	3-3½	5⅔	⅜"	⅞"	58
CSCF4860N6	4-5	5⅔	⅜"	⅞"	65

\* (ft<sup>2</sup>)

### DIMENSIONS

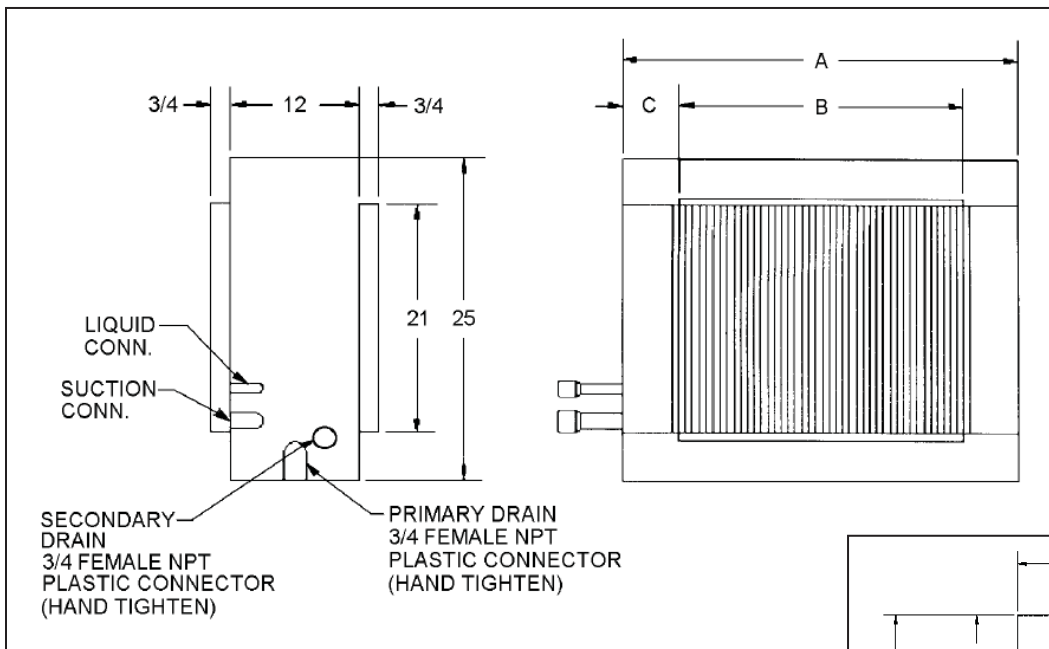

Model	Cabinet Dimensions			Plenum Opening		C Width	Coil Dimensions	
	W (A)	D	H	W (B)	H		W	H
CSCF1824N6	25½"	12"	25"	16"	21"	6"	19¼"	24"
CSCF3036N6	33½"	12"	25"	24"	21"	6"	28"	24"
CSCF3642N6	39½"	12"	25"	30"	21"	6"	34"	24"
CSCF4860N6	39½"	12"	25"	30"	21"	6"	34"	24"

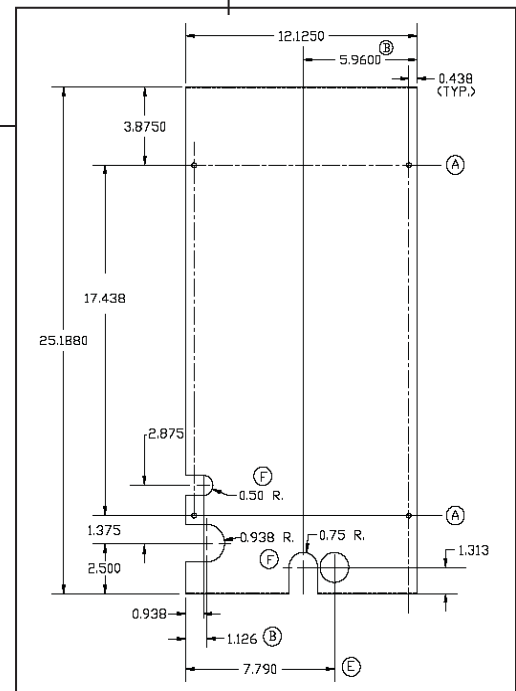

Detail of Access Door

# AIRFLOW DATA FOR CA\*F

## AIR QUANTITY (SCFM) vs. PRESSURE DROP (IN. WC)

SCFM		400	500	600	700	800	900	1000	1100	1200								
CA*F1824A6*	Wet	0.071	0.099	0.142	0.183	0.230	0.280	0.331	0.389	---								
	Dry	0.062	0.090	0.122	0.154	0.189	0.231	0.278	0.331	0.390								
CA*F1824B6*	Wet	0.021	0.032	0.049	0.071	0.089	0.120	0.128	0.159	0.190								
	Dry	0.011	0.022	0.029	0.041	0.052	0.069	0.078	0.101	0.120								
CA*F1824C6*	Wet	0.017	0.025	0.043	0.061	0.079	0.107	0.114	0.140	0.164								
	Dry	0.011	0.017	0.024	0.035	0.044	0.063	0.075	0.094	0.113								
SCFM		600	700	800	900	1000	1100	1200	1300	1400	1500							
CA*F3030A6*	Wet	0.151	0.173	0.204	0.238	0.267	0.281	0.326	0.380	0.406	0.451							
	Dry	0.069	0.083	0.117	0.132	0.148	0.183	0.206	0.239	0.290	0.338							
CA*F3030B6*	Wet	0.090	0.120	0.150	0.180	0.210	0.240	0.280	0.330	0.370	0.420							
	Dry	0.080	0.100	0.130	0.150	0.180	0.210	0.250	0.280	0.320	0.360							
CA*F3030C6*	Wet	0.071	0.087	0.120	0.134	0.155	0.180	0.209	0.249	0.284	0.328							
	Dry	0.050	0.067	0.098	0.113	0.135	0.169	0.189	0.213	0.245	0.275							
CA*F3030D6*	Wet	0.069	0.060	0.090	0.108	0.136	0.168	0.206	0.244	0.288	0.337							
	Dry	0.029	0.043	0.070	0.082	0.098	0.125	0.141	0.153	0.177	0.200							
SCFM		600	700	800	900	1000	1100	1200	1300	1400	1500	1600						
CA*F3131B26*	Wet	0.041	0.049	0.061	0.078	0.090	0.113	0.131	0.140	0.162	0.178	0.210						
	Dry	0.021	0.031	0.039	0.048	0.061	0.072	0.079	0.091	0.110	0.122	0.141						
CA*F3131C6*	Wet	0.035	0.034	0.038	0.051	0.059	0.073	0.087	0.094	0.110	0.125	0.145						
	Dry	0.014	0.022	0.028	0.036	0.045	0.054	0.061	0.068	0.081	0.091	0.108						
SCFM		600	700	800	900	1000	1100	1200	1300	1400	1500	1600	1700	1800	1900	2000	2100	2200
CA*F3636A6*	Wet	0.13	0.17	0.220	0.280	0.310	0.380	0.450	0.530	0.610	0.690	0.790	0.870	0.910	0.950	1.030	1.130	1.190
	Dry	0.13	0.16	0.200	0.230	0.280	0.320	0.380	0.450	0.520	0.590	0.670	0.710	0.790	0.870	0.970	1.060	1.160
CA*F3636B6*	Wet	0.11	0.13	0.160	0.180	0.220	0.260	0.300	0.350	0.400	0.460	0.520	0.570	0.600	0.660	0.720	0.790	0.850
	Dry	0.11	0.13	0.160	0.170	0.210	0.240	0.270	0.330	0.370	0.420	0.470	0.520	0.550	0.610	0.660	0.720	0.770
CA*F3636C6*	Wet	0.1	0.12	0.160	0.170	0.210	0.250	0.290	0.340	0.380	0.430	0.480	0.540	0.550	0.610	0.670	0.720	0.780
	Dry	0.09	0.11	0.130	0.140	0.160	0.180	0.220	0.250	0.280	0.320	0.350	0.370	0.410	0.450	0.490	0.530	0.570
CA*F3636D6*	Wet	0.08	0.11	0.130	0.140	0.170	0.200	0.230	0.270	0.310	0.350	0.390	0.430	0.460	0.500	0.560	0.620	0.660
	Dry	0.09	0.11	0.130	0.140	0.160	0.190	0.220	0.240	0.270	0.300	0.340	0.380	0.410	0.440	0.490	0.530	0.580
SCFM		600	700	800	900	1000	1100	1200	1300	1400	1500	1600	1700	1800	1900	2000	2100	2200
CA*F3642C6*	Wet	0.07	0.09	0.110	0.120	0.140	0.170	0.200	0.230	0.260	0.290	0.330	0.360	0.380	0.420	0.460	0.500	0.540
	Dry	0.07	0.08	0.100	0.110	0.130	0.150	0.170	0.200	0.230	0.250	0.280	0.310	0.330	0.370	0.400	0.430	0.470
CA*F3642D6*	Wet	0.07	0.09	0.110	0.110	0.140	0.160	0.190	0.210	0.240	0.270	0.300	0.330	0.350	0.380	0.420	0.460	0.480
	Dry	0.06	0.08	0.090	0.100	0.110	0.130	0.150	0.170	0.190	0.220	0.240	0.260	0.280	0.300	0.330	0.360	0.390
SCFM		800	900	1000	1100	1200	1300	1400	1500	1600	1700	1800	1900	2000	2100	2200		
CA*F3743C6*	Wet	0.083	0.093	0.113	0.133	0.143	0.163	0.183	0.213	0.243	0.263	0.293	0.323	0.353	0.383	0.423		
	Dry	0.073	0.083	0.103	0.113	0.133	0.153	0.163	0.193	0.213	0.233	0.263	0.293	0.313	0.343	0.373		
CA*F3743D6*	Wet	0.074	0.080	0.089	0.107	0.120	0.129	0.138	0.169	0.188	0.209	0.229	0.251	0.273	0.279	0.306		
	Dry	0.046	0.056	0.074	0.076	0.086	0.107	0.110	0.126	0.147	0.160	0.176	0.196	0.210	0.230	0.253		
SCFM		1000	1100	1200	1300	1400	1500	1600	1700	1800	1900	2000	2100	2200				
CA*F4860C6*	Wet	0.167	0.175	0.191	0.244	0.266	0.299	0.355	0.370	0.413	0.454	0.498	0.586	0.601				
	Dry	0.160	0.157	0.194	0.206	0.246	0.264	0.220	0.265	0.290	0.309	0.364	0.389	0.562				
CA*F4860D6*	Wet	0.138	0.156	0.177	0.196	0.226	0.247	0.275	0.298	0.327	0.349	0.395	0.460	0.485				
	Dry	0.126	0.138	0.157	0.176	0.187	0.200	0.180	0.210	0.230	0.250	0.280	0.300	0.417				
SCFM		1000	1100	1200	1300	1400	1500	1600	1700	1800	1900	2000	2100	2200				
CA*F4961C6*	Wet	0.209	0.217	0.233	0.286	0.308	0.341	0.397	0.412	0.455	0.496	0.540	0.628	0.643				
	Dry	0.202	0.199	0.236	0.248	0.288	0.306	0.262	0.307	0.332	0.351	0.406	0.431	0.604				
CA*F4961D6*	Wet	0.140	0.158	0.179	0.198	0.228	0.249	0.277	0.300	0.329	0.351	0.397	0.462	0.487				
	Dry	0.128	0.140	0.159	0.178	0.189	0.202	0.182	0.212	0.232	0.252	0.282	0.302	0.419				

# PRODUCT SPECIFICATIONS

## AIRFLOW DATA FOR CHPF

AIR QUANTITY (SCFM) vs. PRESSURE DROP (IN. WC)

	SCFM	600	700	800	900	1000	1100	1200	1300	1400						
CHPF 1824A6*	Wet	0.132	0.179	0.222	0.272	0.327	0.381	0.456	0.522	0.605						
	Dry	0.126	0.165	0.206	0.249	0.302	0.354	0.414	0.478	0.563						
	SCFM	600	700	800	900	1000	1100	1200	1300	1400	1500	1600				
CHPF 2430B6*	Wet	0.106	0.124	0.152	0.184	0.218	0.258	0.301	0.350	0.406	0.460	0.514				
	Dry	0.101	0.122	0.145	0.174	0.209	0.247	0.288	0.333	0.381	0.428	0.484				
	SCFM	600	700	800	900	1000	1100	1200	1300	1400	1500	1600				
CHPF 3636B6*	Wet	0.107	0.131	0.167	0.199	0.239	0.291	0.338	0.389	0.439	0.494	0.552				
	Dry	0.102	0.126	0.152	0.184	0.220	0.259	0.303	0.349	0.401	0.458	0.516				
	SCFM	800	900	1000	1100	1200	1300	1400	1500	1600	1700	1800	1900	2000	2100	2200
CHPF 3642C6*	Wet	0.083	0.103	0.126	0.151	0.178	0.208	0.240	0.274	0.310	0.346	0.383	---	---	---	---
	Dry	0.073	0.096	0.120	0.144	0.169	0.196	0.224	0.254	0.286	0.319	0.354	---	---	---	---
CHPF 3642D6*	Wet	0.030	0.040	0.040	0.050	0.060	0.070	0.080	0.080	0.090	0.100	0.110	0.130	0.140	0.150	0.160
	Dry	0.040	0.050	0.060	0.070	0.080	0.080	0.090	0.100	0.110	0.120	0.120	0.120	0.150	0.160	0.180
	SCFM	800	900	1000	1100	1200	1300	1400	1500	1600	1700	1800	1900	2000	2100	2200
CHPF 3743C6*	Wet	0.133	0.153	0.176	0.201	0.228	0.258	0.290	0.324	0.360	0.396	0.433	---	---	---	---
	Dry	0.123	0.146	0.170	0.194	0.219	0.246	0.274	0.304	0.336	0.369	0.404	---	---	---	---
CHPF 3743D6*	Wet	0.101	0.105	0.115	0.125	0.145	0.165	0.185	0.215	0.235	0.265	0.295	0.315	0.355	0.375	0.405
	Dry	0.072	0.095	0.105	0.115	0.135	0.155	0.185	0.205	0.225	0.255	0.275	0.305	0.335	0.365	0.395
	SCFM	900	1000	1100	1200	1300	1400	1500	1600	1700	1800	1900	2000	2100	2200	
CHPF 4860D6*	Wet	0.101	0.121	0.131	0.161	0.181	0.201	0.231	0.261	0.291	0.321	0.361	0.391	0.431	0.471	
	Dry	0.101	0.121	0.141	0.161	0.181	0.201	0.221	0.251	0.281	0.311	0.341	0.371	0.411	0.441	

## AIRFLOW DATA FOR CSCF

AIR QUANTITY (SCFM) vs. PRESSURE DROP (IN. WC)

	SCFM	500	600	700	800	900	1000	1100	1200							
CSCF 1824N6*	Wet	0.011	0.027	0.049	0.067	0.095	0.121	0.141	0.153							
	Dry	0.007	0.016	0.029	0.041	0.056	0.071	0.089	0.108							
	SCFM	700	800	900	1000	1100	1200	1300	1400							
CSCF 3036N6*	Wet	0.019	0.023	0.030	0.039	0.049	0.052	0.070	0.081							
	Dry	0.060	0.013	0.020	0.028	0.036	0.045	0.053	0.063							
	SCFM	800	900	1000	1100	1200	1300	1400	1500	1600	1700	1800	1900	2000	2100	2200
CSCF 3642N6*	Wet	0.011	0.016	0.021	0.034	0.044	0.062	0.073	0.096	0.106	0.113	0.123	0.14	0.15	0.21	0.26
	Dry	0.005	0.010	0.016	0.022	0.029	0.035	0.043	0.051	0.062	0.071	0.080	0.1	0.12	0.18	0.24
	SCFM	800	900	1000	1100	1200	1300	1400	1500	1600	1700	1800	1900	2000	2100	2200
CSCF 4860N6*	Wet	0.021	0.033	0.045	0.055	0.067	0.090	0.103	0.125	0.135	0.156	0.188	0.23	0.25	0.28	0.31
	Dry	0.014	0.021	0.030	0.037	0.047	0.055	0.065	0.088	0.095	0.103	0.121	0.18	0.2	0.23	0.25

