

TECHNICAL GUIDE

TECHNICAL GUIDE

**PREMIUM SERIES
SPLIT-SYSTEM HEAT PUMPS
18 SEER – R-410A – 1 PHASE
2 THRU 5 NOMINAL TONS
MODELS: HL8B024 THRU 060**



Due to continuous product improvement, specifications are subject to change without notice.

Visit us on the web at

www.upgnet.com and www.fraserjohnston.com

Additional rating information can be found at

www.ahridirectory.org

WARRANTY SUMMARY*

Extended 10-Years limited parts warranty.

Extended Lifetime limited compressor warranty.

Extended parts and compressor warranties require online registration within 90 days of purchase for replacement or closing for new home construction.

*Does not apply to R-22 models, 3-Phase models, or internet sales.

See Limited Warranty certificate in User's Information Manual for details.

DESCRIPTION

The 18 SEER Series unit is the outdoor part of a versatile climate system. It is designed with a matching indoor coil component from Johnson Controls Unitary Products. Available for typical applications, this climate system is supported with accessories and documents to serve specific functions.

FEATURES

Superior Coil Protection - A stamped, decorative metal coil guard protects the tube-in-fin coil from debris and other damaging material.

Protected Compressor - The compressor is safeguarded against abnormal pressures and temperatures by an internal pressure relief valve, an internal temperature sensor, and factory high and low pressure system controls. A factory installed liquid line filter-drier further protects the compressor against moisture and debris.

Environmentally Friendly Refrigerant - The next generation refrigerant R-410A delivers environmentally friendly performance with zero ozone depletion.

Durable Finish - An automotive quality finish provides the ultimate protection from harmful UV rays and rust creep, ensuring a long-lasting, high quality appearance. A powder-paint topcoat is applied over a baked-on primer using a galvanized, zinc coated steel base material. The result is a finish that has been proven in testing to provide 33% greater durability than conventional powder-coat finishes.

Hot Heat Pump - An optional mode that slows the indoor fan for higher register air temperatures and premium comfort.

Sound Reducing System - Features combination of swept-wing fan, composite base pan, isolated compressor compartment, and two-stage compressor to reduce overall sound to a mere whisper.

Low RPM ECM Fan Motor - Helps to reduce airflow noise.

Swept Wing Fan - A fan design boasting technology adapted from aeronautic and defense engineering provides for whisper-quiet operation by allowing air to flow smoothly and efficiently across the fan tips.

Composite Base Pan - The strong and durable composite base pan provides added strength while resisting rust and corrosion, as well as reducing sound and vibration.

Isolated Compressor Compartment - A molded composite bulkhead isolates the refrigeration components and the compressor from the rest of the unit, reducing sound and vibration.

Lower Installed Cost - Designed to provide enhanced installability by featuring a slide-down control compartment that allows easy access to control components, along with angled service valves to reduce overall installation time and cost. Factory charged for a 15 foot lineset.

Factory Installed Filter-Drier - A factory installed, solid core liquid line filter-drier removes harmful debris and moisture from the system.

Easy Service Access - A full end, full service access panel with handle makes for easy entry to internal components.

Communications Capable - Requiring only a simple 4-wire installation, the communicating capability enables the use of the Touch Screen Communicating Control, allowing real time visibility of system operation and the use of diagnostic features, while still maintaining the ability to function with a traditional thermostat.

Complete System Control - These heat pumps utilize an unique microprocessor defrost control system to provide optimal comfort as well as monitor the overall system for reliable operation. In the event improper operating conditions occur (high temperature and/or high pressure), the system will automatically shut the system down to extend the life of the heat pump. The defrost control features an internal memory to aid the technician in troubleshooting, reducing service time and cost.

Premium System Warranty - Limited lifetime compressor warranty when registered online within 90 days of installation.

Agency Listed - Safety certified by CSA to UL 1995 / CSA 22.2. Performance certified to ANSI/AHRI Standard 210/240 in accordance with the Unitary Small Equipment certification program.

Physical and Electrical Data

MODEL	HL8B024F4(C)	HL8B036F4(C)	HL8B048F4(C)	HL8B060F4(C)
Unit Supply Voltage	208-230V, 1 ϕ , 60Hz			
Normal Voltage Range ¹	187 to 252			
Minimum Circuit Ampacity	17.5	21.8	29.2	36.9
Max. Overcurrent Device Amps ²	25	35	50	60
Min. Overcurrent Device Amps ³	20	25	30	40
Compressor Amps	Type	2-Stage Scroll	2-Stage Scroll	2-Stage Scroll
	Rated Load	11.8	15.2	21.1
	Locked Rotor	58	83	104
Crankcase Heater	No	No	No	No
Factory External Discharge Muffler	Yes	Yes	Yes	Yes
Factory External Check Valve	No	No	No	No
HS Kit Required with TXV ⁴	No	No	No	No
Fan Diameter Inches	24	24	24	24
Fan Motor	Rated HP	1/3	1/3	1/3
	Rated Load Amps	2.8	2.8	2.8
	Nominal RPM	685	685	685
	Nominal CFM	2990	3345	3300
Coil	Face Area Sq. Ft.	23.6	23.6	23.6
	Rows Deep	2	2	2
	Fins / Inch	16	16	14
Liquid Line OD (in) (Field Installed)	3/8	3/8	3/8	3/8
Vapor Line OD (in) (Field Installed)	3/4	3/4	7/8	7/8
Unit Charge (Lbs. - Oz.) ⁵	14 - 15	11 - 8	13 - 1	14 - 4
Charge Per Foot, Oz.	0.62	0.62	0.67	0.67
Operating Weight Lbs.	295	295	320	325

1. Rated in accordance with AHRI Standard 110-2012, utilization range "A".
2. Dual element fuses or HACR circuit breaker. Maximum allowable overcurrent protection.
3. Dual element fuses or HACR circuit breaker. Minimum recommended overcurrent protection.
4. See Hard Start Kit Accessory Installation Manual for Hard Start Kit part number for each model.
5. The Unit Charge is correct for the outdoor unit, smallest matched indoor unit, and 15 feet of refrigerant tubing. For tubing lengths other than 15 feet, add or subtract the amount of refrigerant, using the difference in actual lineset length (not equivalent length) multiplied by the per foot value.

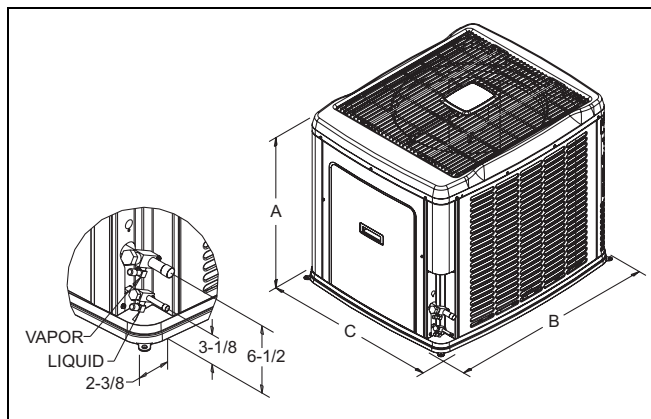

Unit Model	Dimensions (Inches)			Refrigerant Connection Service Valve Size	
	A	B	C	Liquid	Vapor
24	40	42-1/4	34	3/8	3/4
36	40	42-1/4	34		
48	40	42-1/4	34		7/8
60	40	42-1/4	34		

All dimensions are in inches and are subject to change without notice.
 Overall height is from bottom of base pan to top of fan guard.
 Overall length and width include screw heads.

System Charge for Various Matched Systems				
Outdoor Unit	HL8B024F4(C)	HL8B036F4(C)	HL8B048F4(C)	HL8B060F4(C)
Required TXV ¹	4G1	4G1	4H1	4K1
Indoor Unit ^{2,3,4}	TXV Kit ⁵ - Additional Charge, Oz			
AHE42D	–	17	–	–
AHE60D	–	–	13	23
AHV24B	0	–	–	–
AHV30B	0	–	–	–
AHV36C	0	0	–	–
AHV42D	–	17	–	–
AHV48D	–	18	0	–
AHV60D	–	–	13	23
FC/MC/PC37	0	0	–	–
FC/MC/PC43	0	0	–	–
FC/MC/PC48	24	17	10	–
FC/MC/PC60	33	18	0	0
FC/MC62	–	44	13	23
FC64	–	55	35	34
UC48	24	17	10	–
UC60	33	18	0	0

Some of the combinations shown in the above System Charge table require Advanced Main Air Circulating Fan indoor product. For approved coil only matches, please see the "COOLING CAPACITY - Upflow, Downflow & Horizontal Furnaces and Coils" table.

FOOTNOTES:

1. For applications requiring a TXV use S1-1TVM*** series kit.
2. A TXV kit must be used with these indoor units to obtain system performance.
3. Systems matched with furnaces or air handlers not equipped with blower-off delays may require blower Time Delay Kit S1-2FD06700224.
4. PC coils cannot be used in downflow or horizontal applications. FC coils cannot be used in horizontal applications.
5. Refer to Cooling and Heating Performance Data tables for actual performance for specified system matches.

PROCEDURES

1. Unit factory charge listed on the unit nameplate includes refrigerant for the outdoor unit, the smallest matched indoor unit, and 15 feet of interconnecting line tubing.
2. Verify the TXV and additional charge required for specific matched indoor unit in the system using the above table.
3. Add additional charge for the amount of interconnecting line tubing greater than 15 feet at the rate specified in Physical and Electrical Data Table.
4. For indoor matches requiring additional charge, the refrigerant needs to be weighed in for specific matched indoor unit and actual lineset length.
5. Permanently mark the unit nameplate with the total system charge. Total System Charge = Base Charge (as shipped) + charge adder for matched indoor unit + charge adder for actual lineset length.

COOLING CAPACITY - With Air Handler Coils

UNIT MODEL	AIR HANDLER		COIL ¹ MODEL	COOLING					
	MODEL	WIDTH		STAGE	RATED CFM	NET MBH		SEER	EER
						TOTAL	SENS.		
18 SEER HP WITH AIR HANDLERS									
HL8B024F4(C)	AHV24B	17.5	-	1	470	19.7	13.6	16.25	20.00
				2	710	22.6	15.6		13.00
	AHV30B	17.5	-	1	500	19.9	13.8	16.50	20.25
				2	775	22.8	16.2		13.00
	AHV36C	21.0	-	1	485	20.1	13.9	16.75	21.00
				2	760	23.0	16.4		13.50
	MV12B	17.5	FC/MC43B	1	620	20.5	14.2	16.75	22.00
				2	800	23.4	16.8		13.50
	MV12D	24.5	FC/MC48D	1	595	20.5	14.1	17.25	22.50
				2	905	24.0	18.0		14.00
	MV12D	24.5	FC/MC60D	1	645	20.5	14.2	17.50	22.50
				2	835	23.8	17.3		14.00
HL8B036F4(C)	AHE42D	24.5	-	1	685	28.2	18.4	17.25	22.75
				2	1180	35.4	25.5		13.75
	AHV36C	21.0	-	1	785	29.0	19.5	17.75	23.25
				2	1215	35.2	25.5		13.25
	AHV42D	24.5	-	1	790	29.2	19.6	18.25	24.00
				2	1180	35.4	25.5		13.75
	AHV48D	24.5	-	1	835	29.6	20.0	18.50	24.25
				2	1155	35.6	25.3		13.75
	MV12B	17.5	FC/MC43B	1	805	29.2	19.6	17.50	23.00
				2	1225	35.4	25.7		13.25
	MV12D	24.5	FC/MC48D	1	785	29.2	19.5	18.00	23.50
				2	1160	35.4	25.5		13.75
	MV12D	24.5	FC/MC60D	1	735	28.6	18.8	17.50	22.75
				2	1135	35.2	24.9		13.50
	MV12D	24.5	FC/MC62D	1	770	29.0	19.4	18.00	23.50
				2	1235	36.0	26.6		14.00
	MV12D	24.5	FC64D	1	780	30.2	20.2	18.50	24.50
				2	1155	36.6	26.7		14.25
	MV16C	21.0	FC/MC43C	1	775	28.8	19.2	17.25	22.50
				2	1200	35.4	25.5		13.50
	MV16C	21.0	FC/MC48C	1	775	29.2	19.5	18.00	23.50
				2	1200	35.2	25.3		13.50
	MV20D	24.5	FC/MC48D	1	860	29.6	20.4	18.00	23.50
				2	1300	36.0	26.9		13.75
	MV20D	24.5	FC/MC60D	1	860	29.8	20.2	18.00	23.75
				2	1300	36.2	26.7		13.75
	MV20D	24.5	FC/MC62D	1	860	29.6	20.4	18.00	23.50
				2	1300	36.4	27.3		14.00
	MV20D	24.5	FC64D	1	860	30.6	21.0	18.75	24.75
				2	1300	37.3	28.1		14.25
MX12BN21	17.5	FC/MC43B	1	740	28.8	19.2	17.25	22.50	
			2	1125	34.8	24.6		13.00	
MX12DN21	24.5	FC/MC48D	1	830	29.6	20.0	18.25	24.00	
			2	1125	35.2	25.1		13.75	
MX12DN21	24.5	FC/MC60D	1	845	29.6	20.0	18.25	24.00	
			2	1150	35.6	25.3		14.00	
MX12DN21	24.5	FC64D	1	880	30.8	21.4	19.00	25.25	
			2	1175	36.8	26.7		14.25	

For notes, see Page 5.

COOLING CAPACITY - With Air Handler Coils (Continued)

UNIT MODEL	AIR HANDLER		COIL ¹ MODEL	COOLING				SEER	EER
	MODEL	WIDTH		STAGE	RATED CFM	NET MBH			
						TOTAL	SENS.		
18 SEER HP WITH AIR HANDLERS									
HL8B048F4(C)	AHE60D	24.5	-	1	1160	39.5	27.3	16.75	22.50
				2	1565	45.5	33.6		12.50
	AHV48D	24.5	-	1	1010	39.0	25.5	16.75	22.75
				2	1585	45.5	32.8		12.00
	AHV60D	24.5	-	1	1000	38.5	25.7	16.75	22.50
				2	1570	45.5	33.4		12.00
	MV16C	21.0	FC/MC48C	1	1035	39.0	25.9	16.50	22.25
				2	1625	45.5	33.2		12.00
	MV16C	21.0	FC60C	1	1035	39.0	25.7	16.50	22.25
				2	1625	45.5	33.2		12.00
	MV20D	24.5	FC/MC48D	1	1025	39.0	25.9	16.50	22.25
				2	1620	45.5	33.4		12.25
	MV20D	24.5	FC/MC60D	1	1020	39.0	25.7	16.50	22.25
				2	1600	45.5	33.2		12.00
	MV20D	24.5	FC/MC62D	1	1085	39.0	26.5	17.00	23.00
				2	1645	46.0	34.5		12.50
	MV20D	24.5	FC64D	1	1075	40.5	27.5	17.50	24.00
				2	1630	47.0	35.2		12.50
MX16CN21	21.0	FC/MC48C	1	1015	39.0	25.9	16.50	22.25	
			2	1600	45.0	33.2		12.00	
MX16CN21	21.0	FC60C	1	1020	39.0	25.7	16.50	22.25	
			2	1600	45.5	33.2		12.00	
HL8B060F4(C)	AHE60D	24.5	-	1	1160	46.5	29.5	15.25	21.00
				2	1835	57.0	40.5		11.75
	AHV60D	24.5	-	1	1090	46.0	28.9	15.25	21.00
				2	1635	56.0	38.0		11.75
	MV20D	24.5	FC/MC60D	1	1160	47.0	29.3	15.00	21.00
				2	1845	56.5	39.0		11.75
	MV20D	24.5	FC/MC62D	1	1185	47.0	30.1	15.50	21.50
				2	1845	57.0	40.5		12.00
	MV20D	24.5	FC64D	1	1160	48.5	30.7	15.75	22.00
				2	1855	58.0	41.5		11.75

Rated in accordance with DOE test procedures (Federal Register 12-27-79 and 3-18-88) and ANSI/AHRI Standard 210/240.
 Cooling MBH based on 80°F entering air temperature, 50% RH (Relative Humidity), and rated air flow.
 EER (Energy Efficiency Ratio) is the total cooling output in BTUs at 95°F (for high stage operation) or 67°F (for low stage operation) outdoor ambient divided by the total electric power in watt-hours at those conditions.
 SEER (Seasonal Energy Efficiency Ratio) is the total cooling output in BTUs during a normal annual usage period for cooling divided by the total electric power input in watt-hours during the same period.

1. MC coils available with a factory installed horizontal drain pan. See price pages for specific model number.
 — = Not applicable.
 MA Modular Air Handlers use Coil Only Ratings.

COOLING CAPACITY - Upflow, Downflow & Horizontal Furnaces and Coils (Coil Only Ratings)

UNIT MODEL	COIL		CFM RANGE (MIN.-MAX.)	COOLING					
	MODEL	WIDTH		STAGE	RATED CFM	NET MBH		SEER ¹	EER
						TOTAL	SENS.		
18 SEER HP COIL ONLY RATINGS									
HL8B024F4(C)	FC/MC/PC48	21.0,24.5	550 – 650	1	600	19.7	13.6	14.75	21.00
			650 – 950	2	800	22.8	16.3		11.75
HL8B036F4(C)	FC/MC62	24.5	800 – 1000	1	900	29.2	20.0	15.50	19.50
			1000 – 1400	2	1200	35.2	25.5		12.50
HL8B048F4(C)	FC/MC62	24.5	1000 – 1400	1	1200	39.0	26.9	14.75	19.25
			1400 – 1800	2	1600	45.0	33.2		11.50
HL8B060F4(C)	FC/MC62	24.5	1150 – 1550	1	1350	47.0	30.9	13.75	18.50
			1600 – 2000	2	1800	56.0	39.5		11.25

1. Requires a 2FD06700224 Blower Time Delay unless a standard furnace is equipped with one.

MA Modular Air Handlers use Coil Only Ratings.

PSC furnaces, such as the TG8S, TGLS, and TG9S, use Coil Only Ratings.

COOLING CAPACITY - With High Efficiency Motor Furnaces

UNIT MODEL	FURNACE		COIL ¹ MODEL	COOLING					
	MODEL	WIDTH		STAGE	RATED CFM	NET MBH		SEER	EER
						TOTAL	SENS.		
18 SEER HP WITH HIGH EFFICIENCY MOTOR FURNACES ²									
HL8B024F4(C)	T*(8,L)V*A12	14.5	FC/MC/PC37A	1	585	20.5	14.1	16.75	21.75
				2	765	23.0	16.4		13.25
	T*(8,L)V*B12	17.5	FC/MC/PC43B	1	515	20.1	13.9	16.00	21.00
				2	790	23.2	16.7		13.50
	T*(8,L)V*C16	21.0	FC/MC/PC43C	1	645	20.7	14.3	17.00	22.25
				2	770	23.2	16.6		13.50
	T*9V*A10	14.5	FC/MC/PC37A	1	570	20.1	14.0	16.00	21.25
				2	790	23.0	16.4		12.50
	T*9V*B12	17.5	FC/MC/PC43B	1	550	20.3	14.1	16.75	21.50
				2	800	23.2	16.7		13.25
	T*9V*C16	21.0	FC/MC/PC48C	1	635	20.7	14.3	17.25	22.75
				2	890	23.8	17.7		13.50
	T*9V*C16	21.0	FC/PC60C	1	635	20.5	14.2	17.50	22.50
				2	890	24.0	17.8		13.75
	T*9V*C16	21.0	UC48C	1	635	21.1	14.6	16.75	23.75
				2	890	23.8	17.8		13.50
	T*9V*C16	21.0	UC60C	1	635	20.5	14.2	17.50	22.50
				2	890	24.0	17.8		13.75
	T*9V*C20	21.0	FC/MC/PC43C	1	630	20.7	14.3	17.25	22.25
				2	890	23.8	17.8		13.50
	T*9V*C20	21.0	FC/MC/PC48C	1	630	20.7	14.3	17.25	22.75
				2	890	23.8	17.7		13.50
	T*9V*C20	21.0	UC48C	1	630	21.1	14.6	16.75	23.75
				2	890	23.8	17.8		13.50
	TM8X080C16MP11	21.0	FC/MC/PC43C	1	630	20.5	14.2	16.75	22.00
				2	800	23.2	16.6		12.75
	TM8X080C16MP11	21.0	FC/MC/PC48C	1	630	20.5	14.2	16.75	22.50
				2	800	23.2	16.6		12.75
	TM8X080C16MP11	21.0	FC/PC60C	1	630	20.5	14.2	17.50	22.50
				2	800	23.4	17.0		12.75
TM8X080C16MP11	21.0	UC48C	1	630	20.9	14.4	16.25	23.25	
			2	800	23.0	16.6		12.75	

For notes, see Page 20.

COOLING CAPACITY - With High Efficiency Motor Furnaces (Continued)

UNIT MODEL	FURNACE		COIL ¹ MODEL	COOLING					
	MODEL	WIDTH		STAGE	RATED CFM	NET MBH		SEER	EER
						TOTAL	SENS.		
18 SEER HP WITH HIGH EFFICIENCY MOTOR FURNACES²									
HL8B024F4(C)	TM8X080C16MP11	21.0	UC60C	1	630	20.5	14.2	17.50	22.50
				2	800	23.4	17.0		12.75
	TM8X100C16MP11	21.0	FC/MC/PC43C	1	630	20.5	14.2	16.75	22.00
				2	800	23.2	16.6		12.75
	TM8X100C16MP11	21.0	FC/MC/PC48C	1	630	20.5	14.2	16.75	22.50
				2	800	23.2	16.6		12.75
	TM8X100C16MP11	21.0	FC/PC60C	1	630	20.5	14.2	17.50	22.50
				2	800	23.4	17.0		12.75
	TM8X100C16MP11	21.0	UC48C	1	630	20.9	14.4	16.25	23.25
				2	800	23.0	16.6		12.75
	TM8X100C16MP11	21.0	UC60C	1	630	20.5	14.2	17.50	22.50
				2	800	23.4	17.0		12.75
	TMLX080C16MP11	21.0	FC/MC/PC43C	1	630	20.5	14.2	16.75	22.00
				2	800	23.2	16.6		12.75
	TMLX080C16MP11	21.0	FC/MC/PC48C	1	630	20.5	14.2	16.75	22.50
				2	800	23.2	16.6		12.75
	TMLX080C16MP11	21.0	FC/PC60C	1	630	20.5	14.2	17.50	22.50
				2	800	23.4	17.0		12.75
	TMLX080C16MP11	21.0	UC48C	1	630	20.9	14.4	16.25	23.25
				2	800	23.0	16.6		12.75
	TMLX080C16MP11	21.0	UC60C	1	630	20.5	14.2	17.50	22.50
				2	800	23.4	17.0		12.75
	TMLX100C16MP11	21.0	FC/MC/PC43C	1	630	20.5	14.2	16.75	22.00
				2	800	23.2	16.6		12.75
TMLX100C16MP11	21.0	FC/MC/PC48C	1	630	20.5	14.2	16.75	22.50	
			2	800	23.2	16.6		12.75	
TMLX100C16MP11	21.0	FC/PC60C	1	630	20.5	14.2	17.50	22.50	
			2	800	23.4	17.0		12.75	
TMLX100C16MP11	21.0	UC48C	1	630	20.9	14.4	16.25	23.25	
			2	800	23.0	16.6		12.75	
TMLX100C16MP11	21.0	UC60C	1	630	20.5	14.2	17.50	22.50	
			2	800	23.4	17.0		12.75	
HL8B036F4(C)	T*(8,L)V*A12	14.5	FC/MC/PC37A	1	730	28.2	18.5	16.50	21.50
				2	1150	34.6	24.5		12.50
	T*(8,L)V*B12	17.5	FC/MC/PC43B	1	860	29.4	20.0	17.00	22.25
				2	1275	35.2	25.7		12.50
	T*(8,L)V*C16	21.0	FC/MC/PC43C	1	770	28.8	19.2	17.25	22.50
				2	1190	35.2	25.3		13.25
	T*(8,L)V*C16	21.0	FC/MC/PC48C	1	725	28.4	18.6	17.00	22.25
				2	1195	35.6	25.7		13.50
	T*(8,L)V*C16	21.0	FC/PC60C	1	710	28.6	18.8	17.50	22.75
				2	1185	35.4	25.1		13.50
	T*(8,L)V*C16	21.0	UC48C	1	810	28.8	19.4	17.50	22.50
				2	1210	35.8	25.9		13.50
	T*(8,L)V*C16	21.0	UC60C	1	810	28.8	19.4	17.75	23.50
				2	1195	35.2	25.3		13.50
	T*(8,L)V*C20	21.0	FC/MC/PC43C	1	740	28.6	18.8	17.25	22.50
				2	1190	35.2	25.3		13.25

For notes, see Page 20.

COOLING CAPACITY - With High Efficiency Motor Furnaces (Continued)

UNIT MODEL	FURNACE		COIL ¹ MODEL	COOLING					
	MODEL	WIDTH		STAGE	RATED CFM	NET MBH		SEER	EER
						TOTAL	SENS.		
18 SEER HP WITH HIGH EFFICIENCY MOTOR FURNACES²									
HL8B036F4(C)	T*(8,L)V*C20	21.0	FC/MC/PC48C	1	715	28.4	18.6	17.25	22.50
				2	1150	35.2	25.1		13.50
	T*(8,L)V*C20	21.0	FC/PC60C	1	800	29.2	19.6	17.75	23.00
				2	1215	35.8	25.7		13.50
	T*(8,L)V*C20	21.0	UC48C	1	720	28.2	18.3	17.25	22.25
				2	1155	35.6	25.3		13.75
	T*(8,L)V*C20	21.0	UC60C	1	800	28.8	19.4	17.75	23.50
				2	1215	35.2	25.3		13.50
	T*9V*B12	17.5	FC/MC/PC43B	1	815	29.2	19.6	17.25	22.25
				2	1200	34.8	25.1		12.75
	T*9V*C16	21.0	FC/MC/PC43C	1	815	29.2	19.6	17.25	22.50
				2	1240	35.2	25.7		13.00
	T*9V*C16	21.0	FC/MC/PC48C	1	780	29.2	19.5	18.00	23.50
				2	1195	35.0	25.1		13.25
	T*9V*C16	21.0	FC/PC60C	1	810	29.4	19.6	17.50	22.75
				2	1235	35.6	25.7		13.25
	T*9V*C16	21.0	UC48C	1	780	28.6	19.1	17.75	23.00
				2	1195	35.4	25.1		13.25
	T*9V*C16	21.0	UC60C	1	810	29.0	19.4	17.25	22.50
				2	1235	35.2	25.7		13.00
	T*9V*C20	21.0	FC/MC/PC43C	1	780	28.8	19.3	17.25	22.75
				2	1200	35.2	25.3		13.25
	T*9V*C20	21.0	FC/MC/PC48C	1	745	28.8	18.9	17.25	22.50
				2	1330	36.0	26.7		13.00
	T*9V*C20	21.0	FC/PC60C	1	770	29.0	19.2	17.50	23.00
				2	1330	36.2	26.7		13.25
	T*9V*C20	21.0	UC48C	1	755	28.4	18.7	17.25	22.00
				2	1330	36.0	26.9		13.00
	T*9V*C20	21.0	UC60C	1	770	28.6	19.0	17.25	22.50
				2	1330	35.8	26.5		13.00
	T*9V*D20	24.5	FC/MC/PC48D	1	830	29.4	19.8	17.75	23.00
				2	1240	35.6	26.1		13.50
	T*9V*D20	24.5	FC/MC/PC60D	1	830	29.6	19.8	17.75	23.25
				2	1225	35.8	25.9		13.50
	T*9V*D20	24.5	FC/MC62D	1	835	29.4	20.0	17.75	23.00
				2	1235	35.8	26.5		13.50
	T*9V*D20	24.5	FC64D	1	835	30.4	20.8	18.25	24.00
				2	1235	36.8	27.1		13.75
	T*9V*D20	24.5	UC48D	1	830	29.0	19.5	17.50	22.50
				2	1240	35.8	26.1		13.50
T*9V*D20	24.5	UC60D	1	830	29.0	19.6	17.50	22.75	
			2	1225	35.4	25.7		13.25	
TM8X060A12MP11	14.5	FC/MC/PC37A	1	770	28.8	19.2	17.25	22.50	
			2	1125	34.6	24.4		12.75	
TM8X080B12MP11	17.5	FC/MC/PC43B	1	805	28.8	19.2	17.25	22.50	
			2	1175	34.6	24.4		12.75	
TM8X080C16MP11	21.0	FC/MC/PC43C	1	775	28.8	19.2	17.25	22.50	
			2	1150	34.8	24.6		13.25	

For notes, see Page 20.

COOLING CAPACITY - With High Efficiency Motor Furnaces (Continued)

UNIT MODEL	FURNACE		COIL ¹ MODEL	COOLING					
	MODEL	WIDTH		STAGE	RATED CFM	NET MBH		SEER	EER
						TOTAL	SENS.		
18 SEER HP WITH HIGH EFFICIENCY MOTOR FURNACES ²									
HL8B036F4(C)	TM8X080C16MP11	21.0	FC/MC/PC48C	1	775	29.2	19.5	18.00	23.50
				2	1150	35.2	25.3		13.50
	TM8X080C16MP11	21.0	FC/MC/PC48D	1	805	29.2	19.5	18.00	23.50
				2	1175	35.2	25.3		13.50
	TM8X080C16MP11	21.0	FC/MC/PC60D	1	800	29.4	19.6	18.25	23.75
				2	1175	35.4	25.3		13.50
	TM8X080C16MP11	21.0	FC/MC62D	1	785	29.2	19.6	18.00	23.50
				2	1175	35.6	25.9		13.50
	TM8X080C16MP11	21.0	FC/PC60C	1	790	29.2	19.4	18.00	23.75
				2	1175	35.4	25.3		13.50
	TM8X080C16MP11	21.0	FC64D	1	795	30.2	20.2	18.50	24.50
				2	1175	36.4	26.5		13.75
	TM8X080C16MP11	21.0	UC48C	1	775	28.6	19.1	17.75	23.00
				2	1150	35.4	25.3		13.50
	TM8X080C16MP11	21.0	UC48D	1	805	28.6	19.1	17.75	23.00
				2	1175	35.4	25.3		13.50
	TM8X080C16MP11	21.0	UC60C	1	790	28.8	19.4	17.75	23.50
				2	1175	35.2	25.3		13.25
	TM8X080C16MP11	21.0	UC60D	1	800	28.8	19.4	17.75	23.50
				2	1175	35.2	25.3		13.50
	TM8X100C16MP11	21.0	FC/MC/PC43C	1	775	28.8	19.2	17.25	22.50
				2	1150	34.8	24.6		13.25
	TM8X100C16MP11	21.0	FC/MC/PC48C	1	775	29.2	19.5	18.00	23.50
				2	1150	35.2	25.3		13.50
	TM8X100C16MP11	21.0	FC/MC/PC48D	1	805	29.2	19.5	18.00	23.50
				2	1175	35.2	25.3		13.50
	TM8X100C16MP11	21.0	FC/MC/PC60D	1	800	29.4	19.6	18.25	23.75
				2	1175	35.4	25.3		13.50
	TM8X100C16MP11	21.0	FC/MC62D	1	785	29.2	19.6	18.00	23.50
				2	1175	35.6	25.9		13.50
	TM8X100C16MP11	21.0	FC/PC60C	1	790	29.2	19.4	18.00	23.75
				2	1175	35.4	25.3		13.50
	TM8X100C16MP11	21.0	FC64D	1	795	30.2	20.2	18.50	24.50
				2	1175	36.4	26.5		13.75
	TM8X100C16MP11	21.0	UC48C	1	775	28.6	19.1	17.75	23.00
				2	1150	35.4	25.3		13.50
	TM8X100C16MP11	21.0	UC48D	1	805	28.6	19.1	17.75	23.00
				2	1175	35.4	25.3		13.50
	TM8X100C16MP11	21.0	UC60C	1	790	28.8	19.4	17.75	23.50
				2	1175	35.2	25.3		13.25
TM8X100C16MP11	21.0	UC60D	1	800	28.8	19.4	17.75	23.50	
			2	1175	35.2	25.3		13.50	
TMLX060A12MP11	14.5	FC/MC/PC37A	1	770	28.8	19.2	17.25	22.50	
			2	1125	34.6	24.4		12.75	
TMLX080B12MP11	17.5	FC/MC/PC43B	1	805	28.8	19.2	17.25	22.50	
			2	1175	34.6	24.4		12.75	
TMLX080C16MP11	21.0	FC/MC/PC43C	1	775	28.8	19.2	17.25	22.50	
			2	1150	34.8	24.6		13.25	

For notes, see Page 20.

COOLING CAPACITY - With High Efficiency Motor Furnaces (Continued)

UNIT MODEL	FURNACE		COIL ¹ MODEL	COOLING					
	MODEL	WIDTH		STAGE	RATED CFM	NET MBH		SEER	EER
						TOTAL	SENS.		
18 SEER HP WITH HIGH EFFICIENCY MOTOR FURNACES²									
HL8B036F4(C)	TMLX080C16MP11	21.0	FC/MC/PC48C	1	775	29.2	19.5	18.00	23.50
				2	1150	35.2	25.3		13.50
	TMLX080C16MP11	21.0	FC/MC/PC48D	1	805	29.2	19.5	18.00	23.50
				2	1175	35.2	25.3		13.50
	TMLX080C16MP11	21.0	FC/MC/PC60D	1	800	29.4	19.6	18.25	23.75
				2	1175	35.4	25.3		13.50
	TMLX080C16MP11	21.0	FC/MC62D	1	785	29.2	19.6	18.00	23.50
				2	1175	35.6	25.9		13.50
	TMLX080C16MP11	21.0	FC/PC60C	1	790	29.2	19.4	18.00	23.75
				2	1175	35.4	25.3		13.50
	TMLX080C16MP11	21.0	FC64D	1	795	30.2	20.2	18.50	24.50
				2	1175	36.4	26.5		13.75
	TMLX080C16MP11	21.0	UC48C	1	775	28.6	19.1	17.75	23.00
				2	1150	35.4	25.3		13.50
	TMLX080C16MP11	21.0	UC48D	1	805	28.6	19.1	17.75	23.00
				2	1175	35.4	25.3		13.50
	TMLX080C16MP11	21.0	UC60C	1	790	28.8	19.4	17.75	23.50
				2	1175	35.2	25.3		13.25
	TMLX080C16MP11	21.0	UC60D	1	800	28.8	19.4	17.75	23.50
				2	1175	35.2	25.3		13.50
	TMLX100C16MP11	21.0	FC/MC/PC43C	1	775	28.8	19.2	17.25	22.50
				2	1150	34.8	24.6		13.25
	TMLX100C16MP11	21.0	FC/MC/PC48C	1	775	29.2	19.5	18.00	23.50
				2	1150	35.2	25.3		13.50
	TMLX100C16MP11	21.0	FC/MC/PC48D	1	805	29.2	19.5	18.00	23.50
				2	1175	35.2	25.3		13.50
	TMLX100C16MP11	21.0	FC/MC/PC60D	1	800	29.4	19.6	18.25	23.75
				2	1175	35.4	25.3		13.50
	TMLX100C16MP11	21.0	FC/MC62D	1	785	29.2	19.6	18.00	23.50
				2	1175	35.6	25.9		13.50
	TMLX100C16MP11	21.0	FC/PC60C	1	790	29.2	19.4	18.00	23.75
				2	1175	35.4	25.3		13.50
	TMLX100C16MP11	21.0	FC64D	1	795	30.2	20.2	18.50	24.50
				2	1175	36.4	26.5		13.75
	TMLX100C16MP11	21.0	UC48C	1	775	28.6	19.1	17.75	23.00
				2	1150	35.4	25.3		13.50
	TMLX100C16MP11	21.0	UC48D	1	805	28.6	19.1	17.75	23.00
				2	1175	35.4	25.3		13.50
	TMLX100C16MP11	21.0	UC60C	1	790	28.8	19.4	17.75	23.50
				2	1175	35.2	25.3		13.25
	TMLX100C16MP11	21.0	UC60D	1	800	28.8	19.4	17.75	23.50
				2	1175	35.2	25.3		13.50
	TM9E060B12MP11	17.5	FC/MC/PC43B	1	730	28.4	18.7	17.25	22.50
				2	1125	34.6	24.4		12.75
	TM9E080B12MP11	17.5	FC/MC/PC43B	1	730	28.4	18.7	17.25	22.50
				2	1125	34.6	24.4		12.75
	TM9E080C16MP11	21.0	FC/MC/PC48D	1	775	29.2	19.5	18.00	23.50
				2	1175	35.0	25.1		13.25

For notes, see Page 20.

COOLING CAPACITY - With High Efficiency Motor Furnaces (Continued)

UNIT MODEL	FURNACE		COIL ¹ MODEL	COOLING					
	MODEL	WIDTH		STAGE	RATED CFM	NET MBH		SEER	EER
						TOTAL	SENS.		
18 SEER HP WITH HIGH EFFICIENCY MOTOR FURNACES ²									
HL8B036F4(C)	TM9E080C16MP11	21.0	FC/MC62D	1	765	29.0	19.3	17.75	23.25
				2	1175	35.4	25.7		13.25
	TM9E080C16MP11	21.0	FC64D	1	775	30.2	20.2	18.50	24.50
				2	1175	36.4	26.3		13.75
	TM9E080C16MP11	21.0	UC48D	1	775	28.6	19.1	17.75	23.00
				2	1175	35.4	25.1		13.25
	TM9E100C16MP11	21.0	FC/MC/PC48D	1	775	29.2	19.5	18.00	23.50
				2	1175	35.0	25.1		13.25
	TM9E100C16MP11	21.0	FC/MC62D	1	765	29.0	19.3	17.75	23.25
				2	1175	35.4	25.7		13.25
	TM9E100C16MP11	21.0	FC64D	1	775	30.2	20.2	18.50	24.50
				2	1175	36.4	26.3		13.75
	TM9E100C16MP11	21.0	UC48D	1	775	28.6	19.1	17.75	23.00
				2	1175	35.4	25.1		13.25
	TM9X060B12MP11	17.5	FC/MC/PC43B	1	730	28.4	18.7	17.25	22.50
				2	1125	34.6	24.4		12.75
	TM9X080B12MP11	17.5	FC/MC/PC43B	1	730	28.4	18.7	17.25	22.50
				2	1125	34.6	24.4		12.75
	TM9X080C16MP11	21.0	FC/MC/PC48D	1	775	29.2	19.5	18.00	23.50
				2	1175	35.0	25.1		13.25
	TM9X080C16MP11	21.0	FC/MC62D	1	765	29.0	19.3	17.75	23.25
				2	1175	35.4	25.7		13.25
	TM9X080C16MP11	21.0	FC64D	1	775	30.2	20.2	18.50	24.50
				2	1175	36.4	26.3		13.75
	TM9X080C16MP11	21.0	UC48D	1	775	28.6	19.1	17.75	23.00
				2	1175	35.4	25.1		13.25
	TM9X100C16MP11	21.0	FC/MC/PC48D	1	775	29.2	19.5	18.00	23.50
				2	1175	35.0	25.1		13.25
TM9X100C16MP11	21.0	FC/MC62D	1	765	29.0	19.3	17.75	23.25	
			2	1175	35.4	25.7		13.25	
TM9X100C16MP11	21.0	FC64D	1	775	30.2	20.2	18.50	24.50	
			2	1175	36.4	26.3		13.75	
TM9X100C16MP11	21.0	UC48D	1	775	28.6	19.1	17.75	23.00	
			2	1175	35.4	25.1		13.25	
HL8B048F4(C)	T*(8,L)V*C16	21.0	FC/MC/PC48C	1	1120	39.5	26.7	16.25	21.75
				2	1565	44.5	32.2		11.25
	T*(8,L)V*C16	21.0	FC/MC/PC48D	1	1120	39.5	26.7	16.25	21.75
				2	1565	44.5	32.2		11.25
	T*(8,L)V*C16	21.0	FC/MC/PC60D	1	1025	39.0	25.7	16.50	22.25
				2	1600	45.0	33.0		11.50
	T*(8,L)V*C16	21.0	FC/MC62D	1	1025	38.5	25.7	16.25	21.75
				2	1635	45.5	34.0		11.75
	T*(8,L)V*C16	21.0	FC/PC60C	1	1025	39.0	25.7	16.50	22.25
				2	1600	45.0	33.0		11.50
	T*(8,L)V*C16	21.0	FC64D	1	1025	40.5	27.5	17.50	24.00
				2	1635	46.5	35.0		12.00
	T*(8,L)V*C16	21.0	UC48C	1	1035	39.0	25.7	16.25	21.75
				2	1615	45.0	33.0		11.50

For notes, see Page 20.

COOLING CAPACITY - With High Efficiency Motor Furnaces (Continued)

UNIT MODEL	FURNACE		COIL ¹ MODEL	COOLING					
	MODEL	WIDTH		STAGE	RATED CFM	NET MBH		SEER	EER
						TOTAL	SENS.		
18 SEER HP WITH HIGH EFFICIENCY MOTOR FURNACES ²									
HL8B048F4(C)	T*(8,L)V*C16	21.0	UC60C	1	1035	38.5	25.5	16.25	21.75
				2	1625	45.0	32.8		11.75
	T*(8,L)V*C20	21.0	FC/MC/PC48C	1	1080	39.0	25.9	16.50	22.25
				2	1640	45.0	33.0		11.50
	T*(8,L)V*C20	21.0	FC/MC/PC48D	1	1080	39.0	25.9	16.50	22.25
				2	1640	45.0	33.0		11.50
	T*(8,L)V*C20	21.0	FC/MC/PC60D	1	1060	39.0	25.7	16.50	22.25
				2	1625	45.5	33.0		11.75
	T*(8,L)V*C20	21.0	FC/MC62D	1	1060	39.0	26.3	16.25	22.00
				2	1620	45.5	33.8		12.00
	T*(8,L)V*C20	21.0	FC/PC60C	1	1060	39.0	25.7	16.50	22.25
				2	1625	45.5	33.0		11.75
	T*(8,L)V*C20	21.0	FC64D	1	1060	40.5	27.5	17.50	24.00
				2	1630	47.0	35.0		12.25
	T*(8,L)V*C20	21.0	UC48C	1	1080	39.0	26.1	16.25	21.75
				2	1640	45.5	33.2		11.50
	T*(8,L)V*C20	21.0	UC60C	1	1015	38.0	25.3	16.25	21.75
				2	1605	45.0	32.8		12.00
	T*9V*C16	21.0	FC/MC/PC48C	1	1050	39.0	25.9	16.50	22.25
				2	1590	45.0	33.0		11.50
	T*9V*C16	21.0	FC/MC/PC48D	1	1050	39.0	25.9	16.50	22.25
				2	1590	45.0	33.0		11.50
	T*9V*C16	21.0	FC/MC/PC60D	1	1050	39.0	25.7	16.50	22.25
				2	1590	45.0	33.0		11.50
	T*9V*C16	21.0	FC/MC62D	1	1040	38.5	26.1	16.25	21.75
				2	1590	45.5	33.4		11.75
	T*9V*C16	21.0	FC/PC60C	1	1050	39.0	25.7	16.50	22.25
				2	1590	45.0	33.0		11.50
	T*9V*C16	21.0	FC64D	1	1040	40.5	27.5	17.50	24.00
				2	1590	46.5	34.8		12.00
	T*9V*C16	21.0	UC48C	1	1050	39.0	25.9	16.50	22.25
				2	1590	44.5	32.0		11.50
	T*9V*C16	21.0	UC60C	1	1050	38.0	25.3	16.25	22.00
				2	1590	44.5	31.6		11.50
	T*9V*C20	21.0	FC/MC/PC48C	1	1055	39.0	25.9	16.50	22.25
				2	1655	45.0	33.0		11.50
	T*9V*C20	21.0	FC/MC/PC48D	1	1055	39.0	25.9	16.50	22.25
				2	1655	45.0	33.0		11.50
	T*9V*C20	21.0	FC/MC/PC60D	1	1055	39.0	25.7	16.50	22.25
				2	1655	45.0	33.0		11.50
T*9V*C20	21.0	FC/MC62D	1	1040	38.5	25.9	16.25	21.75	
			2	1655	45.5	33.8		11.50	
T*9V*C20	21.0	FC/PC60C	1	1055	39.0	25.7	16.50	22.25	
			2	1655	45.0	33.0		11.50	
T*9V*C20	21.0	FC64D	1	1040	40.5	27.5	17.50	24.00	
			2	1655	46.5	34.8		11.75	
T*9V*C20	21.0	UC48C	1	1055	39.0	25.9	16.25	21.75	
			2	1655	45.5	33.2		11.50	

For notes, see Page 20.

COOLING CAPACITY - With High Efficiency Motor Furnaces (Continued)

UNIT MODEL	FURNACE		COIL ¹ MODEL	COOLING					
	MODEL	WIDTH		STAGE	RATED CFM	NET MBH		SEER	EER
						TOTAL	SENS.		
18 SEER HP WITH HIGH EFFICIENCY MOTOR FURNACES ²									
HL8B048F4(C)	T*9V*C20	21.0	UC60C	1	1055	38.5	25.7	16.00	21.50
				2	1655	45.0	33.0		11.50
	T*9V*D20	24.5	FC/MC/PC48D	1	1060	39.0	25.9	16.50	22.25
				2	1645	45.0	33.0		11.50
	T*9V*D20	24.5	FC/MC/PC60D	1	1070	39.0	25.7	16.50	22.25
				2	1615	45.0	33.0		11.75
	T*9V*D20	24.5	FC/MC62D	1	1085	39.0	26.5	16.25	21.75
				2	1630	45.5	33.8		11.75
	T*9V*D20	24.5	FC64D	1	1085	40.5	27.5	17.50	24.00
				2	1630	46.5	34.8		12.00
	T*9V*D20	24.5	UC48D	1	1060	39.0	25.9	16.25	21.75
				2	1645	45.5	33.2		11.50
	T*9V*D20	24.5	UC60D	1	1070	38.5	25.7	16.00	21.50
				2	1615	45.0	32.6		11.50
	TM8X080C16MP11	21.0	FC/MC/PC48C	1	1030	39.0	25.9	16.50	22.25
				2	1525	44.5	32.0		11.50
	TM8X080C16MP11	21.0	FC/MC/PC48D	1	1045	39.0	25.9	16.50	22.25
				2	1550	45.0	33.0		11.75
	TM8X080C16MP11	21.0	FC/MC/PC60D	1	1045	39.0	25.7	16.50	22.25
				2	1550	45.5	33.0		11.75
	TM8X080C16MP11	21.0	FC/MC62D	1	1040	38.5	26.1	16.50	22.25
				2	1550	45.5	33.0		11.75
	TM8X080C16MP11	21.0	FC/PC60C	1	1020	38.5	25.5	16.50	22.25
				2	1525	44.5	32.0		11.50
	TM8X080C16MP11	21.0	FC64D	1	1045	40.5	27.5	17.50	24.00
				2	1550	46.5	34.8		12.00
	TM8X080C16MP11	21.0	UC48C	1	1030	39.0	25.9	16.50	22.25
				2	1525	45.0	32.0		11.50
	TM8X080C16MP11	21.0	UC48D	1	1045	39.0	25.9	16.50	22.25
				2	1550	45.0	32.0		11.50
	TM8X080C16MP11	21.0	UC60C	1	1020	38.0	25.3	16.25	22.00
				2	1525	44.5	31.8		11.50
	TM8X080C16MP11	21.0	UC60D	1	1045	38.0	25.3	16.25	22.00
				2	1550	44.5	31.8		11.50
	TM8X100C16MP11	21.0	FC/MC/PC48C	1	1030	39.0	25.9	16.50	22.25
				2	1525	44.5	32.0		11.50
	TM8X100C16MP11	21.0	FC/MC/PC48D	1	1045	39.0	25.9	16.50	22.25
				2	1550	45.0	33.0		11.75
	TM8X100C16MP11	21.0	FC/MC/PC60D	1	1045	39.0	25.7	16.50	22.25
				2	1550	45.5	33.0		11.75
TM8X100C16MP11	21.0	FC/MC62D	1	1040	38.5	26.1	16.50	22.25	
			2	1550	45.5	33.0		11.75	
TM8X100C16MP11	21.0	FC/PC60C	1	1020	38.5	25.5	16.50	22.25	
			2	1525	44.5	32.0		11.50	
TM8X100C16MP11	21.0	FC64D	1	1045	40.5	27.5	17.50	24.00	
			2	1550	46.5	34.8		12.00	
TM8X100C16MP11	21.0	UC48C	1	1030	39.0	25.9	16.50	22.25	
			2	1525	45.0	32.0		11.50	

For notes, see Page 20.

COOLING CAPACITY - With High Efficiency Motor Furnaces (Continued)

UNIT MODEL	FURNACE		COIL ¹ MODEL	COOLING					
	MODEL	WIDTH		STAGE	RATED CFM	NET MBH		SEER	EER
						TOTAL	SENS.		
18 SEER HP WITH HIGH EFFICIENCY MOTOR FURNACES²									
HL8B048F4(C)	TM8X100C16MP11	21.0	UC48D	1	1045	39.0	25.9	16.50	22.25
				2	1550	45.0	32.0		11.50
	TM8X100C16MP11	21.0	UC60C	1	1020	38.0	25.3	16.25	22.00
				2	1525	44.5	31.8		11.50
	TM8X100C16MP11	21.0	UC60D	1	1045	38.0	25.3	16.25	22.00
				2	1550	44.5	31.8		11.50
	TM8X100C20MP11	21.0	FC/MC/PC48C	1	1090	39.0	26.5	16.50	22.25
				2	1550	45.0	32.4		11.75
	TM8X100C20MP11	21.0	FC/MC/PC48D	1	1105	39.5	26.7	16.75	22.50
				2	1575	45.0	32.6		11.75
	TM8X100C20MP11	21.0	FC/MC/PC60D	1	1105	39.5	26.5	16.75	22.50
				2	1575	45.0	32.6		11.75
	TM8X100C20MP11	21.0	FC/MC62D	1	1100	39.5	26.9	16.75	22.50
				2	1575	45.5	33.2		11.75
	TM8X100C20MP11	21.0	FC/PC60C	1	1085	39.0	25.7	16.50	22.25
				2	1550	45.5	33.2		11.75
	TM8X100C20MP11	21.0	UC48C	1	1090	39.0	26.3	16.75	22.25
				2	1550	45.0	32.4		11.75
	TM8X100C20MP11	21.0	UC48D	1	1105	39.5	26.7	16.75	22.50
				2	1575	45.0	32.8		11.75
	TM8X100C20MP11	21.0	UC60C	1	1085	38.5	26.1	16.25	22.00
				2	1550	44.5	32.2		11.75
	TM8X100C20MP11	21.0	UC60D	1	1105	39.0	26.3	16.50	22.25
				2	1575	45.0	32.4		11.75
	TM8X120C20MP11	21.0	FC/MC/PC48C	1	1090	39.0	26.5	16.50	22.25
				2	1550	45.0	32.4		11.75
	TM8X120C20MP11	21.0	FC/MC/PC48D	1	1105	39.5	26.7	16.75	22.50
				2	1575	45.0	32.6		11.75
	TM8X120C20MP11	21.0	FC/MC/PC60D	1	1105	39.5	26.5	16.75	22.50
				2	1575	45.0	32.6		11.75
	TM8X120C20MP11	21.0	FC/MC62D	1	1100	39.5	26.9	16.75	22.50
				2	1575	45.5	33.2		11.75
	TM8X120C20MP11	21.0	FC/PC60C	1	1085	39.0	25.7	16.50	22.25
				2	1550	45.5	33.2		11.75
	TM8X120C20MP11	21.0	UC48C	1	1090	39.0	26.3	16.75	22.25
				2	1550	45.0	32.4		11.75
	TM8X120C20MP11	21.0	UC48D	1	1105	39.5	26.7	16.75	22.50
				2	1575	45.0	32.8		11.75
	TM8X120C20MP11	21.0	UC60C	1	1085	38.5	26.1	16.25	22.00
				2	1550	44.5	32.2		11.75
	TM8X120C20MP11	21.0	UC60D	1	1105	39.0	26.3	16.50	22.25
				2	1575	45.0	32.4		11.75
	TMLX080C16MP11	21.0	FC/MC/PC48C	1	1030	39.0	25.9	16.50	22.25
				2	1525	44.5	32.0		11.50
	TMLX080C16MP11	21.0	FC/MC/PC48D	1	1045	39.0	25.9	16.50	22.25
				2	1550	45.0	33.0		11.75
	TMLX080C16MP11	21.0	FC/MC/PC60D	1	1045	39.0	25.7	16.50	22.25
				2	1550	45.5	33.0		11.75

For notes, see Page 20.

COOLING CAPACITY - With High Efficiency Motor Furnaces (Continued)

UNIT MODEL	FURNACE		COIL ¹ MODEL	COOLING					
	MODEL	WIDTH		STAGE	RATED CFM	NET MBH		SEER	EER
						TOTAL	SENS.		
18 SEER HP WITH HIGH EFFICIENCY MOTOR FURNACES ²									
HL8B048F4(C)	TMLX080C16MP11	21.0	FC/MC62D	1	1040	38.5	26.1	16.50	22.25
				2	1550	45.5	33.0		11.75
	TMLX080C16MP11	21.0	FC/PC60C	1	1020	38.5	25.5	16.50	22.25
				2	1525	44.5	32.0		11.50
	TMLX080C16MP11	21.0	FC64D	1	1045	40.5	27.5	17.50	24.00
				2	1550	46.5	34.8		12.00
	TMLX080C16MP11	21.0	UC48C	1	1030	39.0	25.9	16.50	22.25
				2	1525	45.0	32.0		11.50
	TMLX080C16MP11	21.0	UC48D	1	1045	39.0	25.9	16.50	22.25
				2	1550	45.0	32.0		11.50
	TMLX080C16MP11	21.0	UC60C	1	1020	38.0	25.3	16.25	22.00
				2	1525	44.5	31.8		11.50
	TMLX080C16MP11	21.0	UC60D	1	1045	38.0	25.3	16.25	22.00
				2	1550	44.5	31.8		11.50
	TMLX100C16MP11	21.0	FC/MC/PC48C	1	1030	39.0	25.9	16.50	22.25
				2	1525	44.5	32.0		11.50
	TMLX100C16MP11	21.0	FC/MC/PC48D	1	1045	39.0	25.9	16.50	22.25
				2	1550	45.0	33.0		11.75
	TMLX100C16MP11	21.0	FC/MC/PC60D	1	1045	39.0	25.7	16.50	22.25
				2	1550	45.5	33.0		11.75
	TMLX100C16MP11	21.0	FC/MC62D	1	1040	38.5	26.1	16.50	22.25
				2	1550	45.5	33.0		11.75
	TMLX100C16MP11	21.0	FC/PC60C	1	1020	38.5	25.5	16.50	22.25
				2	1525	44.5	32.0		11.50
	TMLX100C16MP11	21.0	FC64D	1	1045	40.5	27.5	17.50	24.00
				2	1550	46.5	34.8		12.00
	TMLX100C16MP11	21.0	UC48C	1	1030	39.0	25.9	16.50	22.25
				2	1525	45.0	32.0		11.50
	TMLX100C16MP11	21.0	UC48D	1	1045	39.0	25.9	16.50	22.25
				2	1550	45.0	32.0		11.50
	TMLX100C16MP11	21.0	UC60C	1	1020	38.0	25.3	16.25	22.00
				2	1525	44.5	31.8		11.50
	TMLX100C16MP11	21.0	UC60D	1	1045	38.0	25.3	16.25	22.00
				2	1550	44.5	31.8		11.50
	TMLX100C20MP11	21.0	FC/MC/PC48C	1	1090	39.0	26.5	16.50	22.25
				2	1550	45.0	32.4		11.75
	TMLX100C20MP11	21.0	FC/MC/PC48D	1	1105	39.5	26.7	16.75	22.50
				2	1575	45.0	32.6		11.75
	TMLX100C20MP11	21.0	FC/MC/PC60D	1	1105	39.5	26.5	16.75	22.50
				2	1575	45.0	32.6		11.75
TMLX100C20MP11	21.0	FC/MC62D	1	1100	39.5	26.9	16.75	22.50	
			2	1575	45.5	33.2		11.75	
TMLX100C20MP11	21.0	FC/PC60C	1	1085	39.0	25.7	16.50	22.25	
			2	1550	45.5	33.2		11.75	
TMLX100C20MP11	21.0	UC48C	1	1090	39.0	26.3	16.75	22.25	
			2	1550	45.0	32.4		11.75	
TMLX100C20MP11	21.0	UC48D	1	1105	39.5	26.7	16.75	22.50	
			2	1575	45.0	32.8		11.75	

For notes, see Page 20.

COOLING CAPACITY - With High Efficiency Motor Furnaces (Continued)

UNIT MODEL	FURNACE		COIL ¹ MODEL	COOLING					
	MODEL	WIDTH		STAGE	RATED CFM	NET MBH		SEER	EER
						TOTAL	SENS.		
18 SEER HP WITH HIGH EFFICIENCY MOTOR FURNACES²									
HL8B048F4(C)	TMLX100C20MP11	21.0	UC60C	1	1085	38.5	26.1	16.25	22.00
				2	1550	44.5	32.2		11.75
	TMLX100C20MP11	21.0	UC60D	1	1105	39.0	26.3	16.50	22.25
				2	1575	45.0	32.4		11.75
	TMLX120C20MP11	21.0	FC/MC/PC48C	1	1090	39.0	26.5	16.50	22.25
				2	1550	45.0	32.4		11.75
	TMLX120C20MP11	21.0	FC/MC/PC48D	1	1105	39.5	26.7	16.75	22.50
				2	1575	45.0	32.6		11.75
	TMLX120C20MP11	21.0	FC/MC/PC60D	1	1105	39.5	26.5	16.75	22.50
				2	1575	45.0	32.6		11.75
	TMLX120C20MP11	21.0	FC/MC62D	1	1100	39.5	26.9	16.75	22.50
				2	1575	45.5	33.2		11.75
	TMLX120C20MP11	21.0	FC/PC60C	1	1085	39.0	25.7	16.50	22.25
				2	1550	45.5	33.2		11.75
	TMLX120C20MP11	21.0	UC48C	1	1090	39.0	26.3	16.75	22.25
				2	1550	45.0	32.4		11.75
	TMLX120C20MP11	21.0	UC48D	1	1105	39.5	26.7	16.75	22.50
				2	1575	45.0	32.8		11.75
	TMLX120C20MP11	21.0	UC60C	1	1085	38.5	26.1	16.25	22.00
				2	1550	44.5	32.2		11.75
	TMLX120C20MP11	21.0	UC60D	1	1105	39.0	26.3	16.50	22.25
				2	1575	45.0	32.4		11.75
	TM9E100C20MP11	21.0	FC/MC/PC48C	1	945	38.0	24.9	16.25	22.00
				2	1500	44.5	31.6		11.50
	TM9E100C20MP11	21.0	FC/MC/PC48D	1	960	38.5	24.9	16.50	22.25
				2	1525	44.5	32.0		11.50
	TM9E100C20MP11	21.0	FC/MC/PC60D	1	960	38.0	24.9	16.50	22.25
				2	1525	44.5	32.0		11.50
	TM9E100C20MP11	21.0	FC/MC62D	1	985	38.0	25.3	16.50	22.25
				2	1550	45.5	33.0		11.75
	TM9E100C20MP11	21.0	FC64D	1	980	39.5	26.3	17.25	23.25
				2	1550	46.0	33.8		12.00
	TM9E100C20MP11	21.0	UC48C	1	945	38.0	24.9	16.50	22.00
				2	1500	44.5	31.8		11.50
	TM9E100C20MP11	21.0	UC48D	1	960	38.5	25.1	16.50	22.00
				2	1525	45.0	32.0		11.50
	TM9E100C20MP11	21.0	UC60D	1	960	38.0	24.7	16.25	21.75
				2	1525	44.5	31.8		11.50
	TM9E120D20MP11	24.5	FC/MC/PC48D	1	965	38.5	25.1	16.50	22.25
				2	1525	44.5	32.0		11.50
	TM9E120D20MP11	24.5	FC/MC/PC60D	1	980	38.5	25.1	16.50	22.50
				2	1550	45.0	32.2		11.75
	TM9E120D20MP11	24.5	FC/MC62D	1	980	38.0	25.3	16.50	22.25
				2	1550	45.5	33.0		11.75
	TM9E120D20MP11	24.5	FC64D	1	960	39.5	26.1	17.00	23.25
				2	1525	46.0	33.8		12.00
	TM9E120D20MP11	24.5	UC48D	1	965	38.5	25.1	16.50	22.25
				2	1525	45.0	32.2		11.75

For notes, see Page 20.

COOLING CAPACITY - With High Efficiency Motor Furnaces (Continued)

UNIT MODEL	FURNACE		COIL ¹ MODEL	COOLING					
	MODEL	WIDTH		STAGE	RATED CFM	NET MBH		SEER	EER
						TOTAL	SENS.		
18 SEER HP WITH HIGH EFFICIENCY MOTOR FURNACES ²									
HL8B048F4(C)	TM9E120D20MP11	24.5	UC60D	1	980	38.0	25.3	16.25	22.00
				2	1550	44.5	31.8		11.75
	TM9X100C20MP11	21.0	FC/MC/PC48C	1	945	38.0	24.9	16.25	22.00
				2	1500	44.5	31.6		11.50
	TM9X100C20MP11	21.0	FC/MC/PC48D	1	960	38.5	24.9	16.50	22.25
				2	1525	44.5	32.0		11.50
	TM9X100C20MP11	21.0	FC/MC/PC60D	1	960	38.0	24.9	16.50	22.25
				2	1525	44.5	32.0		11.50
	TM9X100C20MP11	21.0	FC/MC62D	1	985	38.0	25.3	16.50	22.25
				2	1550	45.5	33.0		11.75
	TM9X100C20MP11	21.0	FC64D	1	980	39.5	26.3	17.25	23.25
				2	1550	46.0	33.8		12.00
	TM9X100C20MP11	21.0	UC48C	1	945	38.0	24.9	16.50	22.00
				2	1500	44.5	31.8		11.50
	TM9X100C20MP11	21.0	UC48D	1	960	38.5	25.1	16.50	22.00
				2	1525	45.0	32.0		11.50
	TM9X100C20MP11	21.0	UC60D	1	960	38.0	24.7	16.25	21.75
				2	1525	44.5	31.8		11.50
	TM9X120D20MP11	24.5	FC/MC/PC48D	1	965	38.5	25.1	16.50	22.25
				2	1525	44.5	32.0		11.50
	TM9X120D20MP11	24.5	FC/MC/PC60D	1	980	38.5	25.1	16.50	22.50
				2	1550	45.0	32.2		11.75
	TM9X120D20MP11	24.5	FC/MC62D	1	980	38.0	25.3	16.50	22.25
				2	1550	45.5	33.0		11.75
TM9X120D20MP11	24.5	FC64D	1	960	39.5	26.1	17.00	23.25	
			2	1525	46.0	33.8		12.00	
TM9X120D20MP11	24.5	UC48D	1	965	38.5	25.1	16.50	22.25	
			2	1525	45.0	32.2		11.75	
TM9X120D20MP11	24.5	UC60D	1	980	38.0	25.3	16.25	22.00	
			2	1550	44.5	31.8		11.75	
HL8B060F4(C)	T*(8,L)V*C16	21.0	FC/PC60C	1	1025	45.5	27.7	14.50	20.25
				2	1600	55.0	36.6		11.25
	T*(8,L)V*C20	21.0	FC/MC/PC60D	1	1060	46.0	28.1	14.75	20.50
				2	1600	55.0	36.8		11.50
	T*(8,L)V*C20	21.0	FC/MC62D	1	1015	45.0	27.7	14.50	20.00
				2	1600	55.5	37.6		11.50
	T*(8,L)V*C20	21.0	FC/PC60C	1	1060	46.0	28.1	14.75	20.50
				2	1600	55.0	36.8		11.50
	T*(8,L)V*C20	21.0	FC64D	1	1060	47.5	29.5	15.25	21.25
				2	1855	58.0	41.0		11.50
	T*(8,L)V*C20	21.0	UC60C	1	1015	44.5	27.3	14.50	20.25
				2	1605	55.0	36.8		11.50
	T*9V*C20	21.0	FC/MC/PC60D	1	1055	45.5	28.1	14.75	20.25
				2	1655	55.5	37.2		11.50
	T*9V*C20	21.0	FC/MC62D	1	1040	45.5	28.1	14.75	20.25
				2	1655	56.0	38.0		11.50
	T*9V*C20	21.0	FC/PC60C	1	1055	45.5	28.1	14.75	20.25
				2	1655	55.5	37.2		11.50

For notes, see Page 20.

COOLING CAPACITY - With High Efficiency Motor Furnaces (Continued)

UNIT MODEL	FURNACE		COIL ¹ MODEL	COOLING					
	MODEL	WIDTH		STAGE	RATED CFM	NET MBH		SEER	EER
						TOTAL	SENS.		
18 SEER HP WITH HIGH EFFICIENCY MOTOR FURNACES²									
HL8B060F4(C)	T*9V*C20	21.0	FC64D	1	1040	47.0	29.1	15.00	21.00
				2	1655	57.0	39.0		11.50
	T*9V*C20	21.0	UC60C	1	1055	45.0	27.7	14.50	20.00
				2	1655	55.0	37.0		11.25
	T*9V*D20	24.5	FC/MC/PC60D	1	1070	46.0	28.3	14.75	20.25
				2	1615	55.0	36.8		11.25
	T*9V*D20	24.5	FC/MC62D	1	1085	45.5	28.7	14.75	20.25
				2	1630	55.5	38.0		11.50
	T*9V*D20	24.5	FC64D	1	1085	47.5	29.7	15.25	21.25
				2	1630	57.0	39.0		11.75
	T*9V*D20	24.5	UC60D	1	1070	45.0	27.9	14.50	20.00
				2	1615	55.0	36.8		11.25
	TM8X080C16MP11	21.0	FC/MC/PC60D	1	1045	46.0	28.1	15.00	20.75
				2	1550	55.0	36.2		11.25
	TM8X080C16MP11	21.0	FC/MC62D	1	1040	45.5	28.1	15.00	20.75
				2	1550	55.0	37.2		11.50
	TM8X080C16MP11	21.0	FC/PC60C	1	1020	45.5	27.7	14.75	20.50
				2	1525	54.5	35.8		11.25
	TM8X080C16MP11	21.0	FC64D	1	1045	47.5	29.3	15.50	21.75
				2	1550	56.5	38.0		11.75
	TM8X080C16MP11	21.0	UC60C	1	1020	45.0	27.5	14.75	20.25
				2	1525	54.0	35.8		11.25
	TM8X080C16MP11	21.0	UC60D	1	1045	45.0	27.5	14.75	20.25
				2	1550	54.0	35.8		11.25
	TM8X100C16MP11	21.0	FC/MC/PC60D	1	1045	46.0	28.1	15.00	20.75
				2	1550	55.0	36.2		11.25
	TM8X100C16MP11	21.0	FC/MC62D	1	1040	45.5	28.1	15.00	20.75
				2	1550	55.0	37.2		11.50
	TM8X100C16MP11	21.0	FC/PC60C	1	1020	45.5	27.7	14.75	20.50
				2	1525	54.5	35.8		11.25
	TM8X100C16MP11	21.0	FC64D	1	1045	47.5	29.3	15.50	21.75
				2	1550	56.5	38.0		11.75
	TM8X100C16MP11	21.0	UC60C	1	1020	45.0	27.5	14.75	20.25
				2	1525	54.0	35.8		11.25
	TM8X100C16MP11	21.0	UC60D	1	1045	45.0	27.5	14.75	20.25
				2	1550	54.0	35.8		11.25
	TM8X100C20MP11	21.0	FC/MC/PC60D	1	1105	46.5	28.7	15.00	21.00
				2	1575	55.0	36.6		11.50
	TM8X100C20MP11	21.0	FC/MC62D	1	1100	46.0	28.9	15.00	20.75
				2	1575	55.5	37.6		11.50
TM8X100C20MP11	21.0	FC/PC60C	1	1085	46.0	28.5	15.00	20.75	
			2	1550	55.0	36.4		11.50	
TM8X100C20MP11	21.0	UC60C	1	1085	45.5	28.1	14.75	20.25	
			2	1550	54.5	36.2		11.25	
TM8X100C20MP11	21.0	UC60D	1	1105	45.5	28.3	14.75	20.50	
			2	1575	54.5	36.4		11.50	
TM8X120C20MP11	21.0	FC/MC/PC60D	1	1105	46.5	28.7	15.00	21.00	
			2	1575	55.0	36.6		11.50	

For notes, see Page 20.

COOLING CAPACITY - With High Efficiency Motor Furnaces (Continued)

UNIT MODEL	FURNACE		COIL ¹ MODEL	COOLING					
	MODEL	WIDTH		STAGE	RATED CFM	NET MBH		SEER	EER
						TOTAL	SENS.		
18 SEER HP WITH HIGH EFFICIENCY MOTOR FURNACES²									
HL8B060F4(C)	TM8X120C20MP11	21.0	FC/MC62D	1	1100	46.0	28.9	15.00	20.75
				2	1575	55.5	37.6		11.50
	TM8X120C20MP11	21.0	FC/PC60C	1	1085	46.0	28.5	15.00	20.75
				2	1550	55.0	36.4		11.50
	TM8X120C20MP11	21.0	UC60C	1	1085	45.5	28.1	14.75	20.25
				2	1550	54.5	36.2		11.25
	TM8X120C20MP11	21.0	UC60D	1	1105	45.5	28.3	14.75	20.50
				2	1575	54.5	36.4		11.50
	TMLX080C16MP11	21.0	FC/MC/PC60D	1	1045	46.0	28.1	15.00	20.75
				2	1550	55.0	36.2		11.25
	TMLX080C16MP11	21.0	FC/MC62D	1	1040	45.5	28.1	15.00	20.75
				2	1550	55.0	37.2		11.50
	TMLX080C16MP11	21.0	FC/PC60C	1	1020	45.5	27.7	14.75	20.50
				2	1525	54.5	35.8		11.25
	TMLX080C16MP11	21.0	FC64D	1	1045	47.5	29.3	15.50	21.75
				2	1550	56.5	38.0		11.75
	TMLX080C16MP11	21.0	UC60C	1	1020	45.0	27.5	14.75	20.25
				2	1525	54.0	35.8		11.25
	TMLX080C16MP11	21.0	UC60D	1	1045	45.0	27.5	14.75	20.25
				2	1550	54.0	35.8		11.25
	TMLX100C16MP11	21.0	FC/MC/PC60D	1	1045	46.0	28.1	15.00	20.75
				2	1550	55.0	36.2		11.25
	TMLX100C16MP11	21.0	FC/MC62D	1	1040	45.5	28.1	15.00	20.75
				2	1550	55.0	37.2		11.50
	TMLX100C16MP11	21.0	FC/PC60C	1	1020	45.5	27.7	14.75	20.50
				2	1525	54.5	35.8		11.25
	TMLX100C16MP11	21.0	FC64D	1	1045	47.5	29.3	15.50	21.75
				2	1550	56.5	38.0		11.75
	TMLX100C16MP11	21.0	UC60C	1	1020	45.0	27.5	14.75	20.25
				2	1525	54.0	35.8		11.25
	TMLX100C16MP11	21.0	UC60D	1	1045	45.0	27.5	14.75	20.25
				2	1550	54.0	35.8		11.25
	TMLX100C20MP11	21.0	FC/MC/PC60D	1	1105	46.5	28.7	15.00	21.00
				2	1575	55.0	36.6		11.50
	TMLX100C20MP11	21.0	FC/MC62D	1	1100	46.0	28.9	15.00	20.75
				2	1575	55.5	37.6		11.50
	TMLX100C20MP11	21.0	FC/PC60C	1	1085	46.0	28.5	15.00	20.75
				2	1550	55.0	36.4		11.50
	TMLX100C20MP11	21.0	UC60C	1	1085	45.5	28.1	14.75	20.25
				2	1550	54.5	36.2		11.25
TMLX100C20MP11	21.0	UC60D	1	1105	45.5	28.3	14.75	20.50	
			2	1575	54.5	36.4		11.50	
TMLX120C20MP11	21.0	FC/MC/PC60D	1	1105	46.5	28.7	15.00	21.00	
			2	1575	55.0	36.6		11.50	
TMLX120C20MP11	21.0	FC/MC62D	1	1100	46.0	28.9	15.00	20.75	
			2	1575	55.5	37.6		11.50	
TMLX120C20MP11	21.0	FC/PC60C	1	1085	46.0	28.5	15.00	20.75	
			2	1550	55.0	36.4		11.50	

For notes, see Page 20.

COOLING CAPACITY - With High Efficiency Motor Furnaces (Continued)

UNIT MODEL	FURNACE		COIL ¹ MODEL	COOLING					
	MODEL	WIDTH		STAGE	RATED CFM	NET MBH		SEER	EER
						TOTAL	SENS.		
18 SEER HP WITH HIGH EFFICIENCY MOTOR FURNACES²									
HL8B060F4(C)	TMLX120C20MP11	21.0	UC60C	1	1085	45.5	28.1	14.75	20.25
				2	1550	54.5	36.2		11.25
	TMLX120C20MP11	21.0	UC60D	1	1105	45.5	28.3	14.75	20.50
				2	1575	54.5	36.4		11.50
	TM9E100C20MP11	21.0	FC/MC/PC60D	1	960	45.0	27.1	14.75	20.50
				2	1525	54.5	35.8		11.25
	TM9E100C20MP11	21.0	FC/MC62D	1	985	45.0	27.5	14.75	20.50
				2	1550	55.0	37.2		11.50
	TM9E100C20MP11	21.0	FC64D	1	980	46.5	28.5	15.25	21.50
				2	1550	56.5	38.0		11.75
	TM9E100C20MP11	21.0	UC60D	1	960	44.0	26.7	14.50	20.00
				2	1525	54.0	35.8		11.25
	TM9E120D20MP11	24.5	FC/MC/PC60D	1	980	45.0	27.5	14.75	20.75
				2	1550	55.0	36.2		11.50
	TM9E120D20MP11	24.5	FC/MC62D	1	980	45.0	27.5	14.75	20.50
				2	1550	55.5	37.2		11.50
	TM9E120D20MP11	24.5	FC64D	1	960	46.5	28.3	15.25	21.25
				2	1525	56.5	37.8		11.75
	TM9E120D20MP11	24.5	UC60D	1	980	45.0	27.5	14.75	20.25
				2	1550	54.5	35.8		11.25
	TM9X100C20MP11	21.0	FC/MC/PC60D	1	960	45.0	27.1	14.75	20.50
				2	1525	54.5	35.8		11.25
	TM9X100C20MP11	21.0	FC/MC62D	1	985	45.0	27.5	14.75	20.50
				2	1550	55.0	37.2		11.50
	TM9X100C20MP11	21.0	FC64D	1	980	46.5	28.5	15.25	21.50
				2	1550	56.5	38.0		11.75
	TM9X100C20MP11	21.0	UC60D	1	960	44.0	26.7	14.50	20.00
				2	1525	54.0	35.8		11.25
	TM9X120D20MP11	24.5	FC/MC/PC60D	1	980	45.0	27.5	14.75	20.75
				2	1550	55.0	36.2		11.50
	TM9X120D20MP11	24.5	FC/MC62D	1	980	45.0	27.5	14.75	20.50
				2	1550	55.5	37.2		11.50
TM9X120D20MP11	24.5	FC64D	1	960	46.5	28.3	15.25	21.25	
			2	1525	56.5	37.8		11.75	
TM9X120D20MP11	24.5	UC60D	1	980	45.0	27.5	14.75	20.25	
			2	1550	54.5	35.8		11.25	

1. MC coils available with a factory installed horizontal drain pan. See price pages for specific model number.

2. High Efficiency Motor Furnaces have B.O.D (Blower on Delay) standard.

PSC furnaces, such as the TG8S, TGLS, and TG9S, use Coil Only Ratings.

HEATING CAPACITY - With Air Handler

UNIT MODEL	AIR HANDLER MODEL	COIL ¹ MODEL	HEATING ²					
			STAGE	RATED CFM	NET MBH		HSPF	COP @ 47°F
					47°F OD	17°F OD		
18 SEER HP WITH AIR HANDLERS								
HL8B024F4(C)	AHV24B	-	1	470	18.3	-	-	3.14
			2	710	23.4	16.9	9.40	3.52
			2*	470	24.2	15.1	8.70	2.86
	AHV30B	-	1	500	18.8	-	-	3.20
			2	775	23.8	17.0	9.45	3.62
			2*	500	24.6	15.2	8.70	2.94
	AHV36C	-	1	485	18.9	-	-	3.24
			2	760	23.8	16.9	9.65	3.74
			2*	485	25.2	15.1	8.85	2.98
	MV12B	FC/MC43B	1	620	19.2	-	-	3.48
			2	800	24.0	16.9	9.60	3.78
			2*	620	25.4	15.2	9.35	3.28
	MV12D	FC/MC48D	1	595	19.0	-	-	3.50
			2	905	24.0	16.8	9.80	4.00
			2*	595	25.0	15.0	9.60	3.30
	MV12D	FC/MC60D	1	645	19.2	-	-	3.62
			2	835	23.8	16.6	9.90	3.92
			2*	645	25.4	14.9	9.80	3.42
HL8B036F4(C)	AHE42D	-	1	685	25.5	-	-	3.28
			2	1180	35.6	24.4	9.95	4.08
			2*	685	35.4	23.8	9.95	2.92
	AHV36C	-	1	785	25.3	-	-	3.46
			2	1215	36.0	24.8	9.65	3.98
			2*	785	35.8	23.6	8.90	3.10
	AHV42D	-	1	790	25.7	-	-	3.52
			2	1180	35.8	24.4	9.90	4.06
			2*	790	34.4	23.6	9.75	3.22
	AHV48D	-	1	835	25.9	-	-	3.60
			2	1155	35.4	24.2	9.95	4.04
			2*	835	35.6	23.2	9.30	3.24
	MV12B	FC/MC43B	1	805	25.9	-	-	3.46
			2	1225	36.0	24.8	9.70	4.00
			2*	805	36.0	23.8	8.95	3.10
	MV12D	FC/MC48D	1	785	25.7	-	-	3.50
			2	1160	35.6	24.4	10.05	4.08
			2*	785	35.8	23.6	9.20	3.14
	MV12D	FC/MC60D	1	735	25.7	-	-	3.40
			2	1135	35.6	24.2	9.75	3.96
			2*	735	35.6	23.4	8.90	2.98
	MV12D	FC/MC62D	1	770	25.5	-	-	3.50
			2	1235	36.0	24.0	10.00	4.20
			2*	770	35.0	23.0	9.80	3.24
	MV12D	FC64D	1	780	26.3	-	-	3.68
			2	1155	36.0	24.2	10.20	4.28
			2*	780	36.4	23.4	9.35	3.32
	MV16C	FC/MC43C	1	775	25.3	-	-	3.38
			2	1200	35.8	24.6	9.80	4.02
			2*	775	35.4	23.8	9.40	3.08
MV16C	FC/MC48C	1	775	25.7	-	-	3.44	
		2	1200	35.6	24.6	9.85	4.02	
		2*	775	36.0	23.6	9.70	3.12	

For notes, see Page 23.

HEATING CAPACITY - With Air Handler (Continued)

UNIT MODEL	AIR HANDLER MODEL	COIL ¹ MODEL	HEATING ²					
			STAGE	RATED CFM	NET MBH		HSPF	COP @ 47°F
					47°F OD	17°F OD		
18 SEER HP WITH AIR HANDLERS								
HL8B036F4(C)	MV20D	FC/MC48D	1	860	26.3	—	—	3.60
			2	1300	36.0	24.8	9.95	4.20
			2*	860	36.4	24.0	9.20	3.28
	MV20D	FC/MC60D	1	860	26.3	—	—	3.60
			2	1300	36.0	24.4	9.90	4.14
			2*	860	36.0	23.6	9.85	3.26
	MV20D	FC/MC62D	1	860	25.9	—	—	3.62
			2	1300	36.0	24.0	10.00	4.24
			2*	860	36.0	23.0	9.85	3.36
	MV20D	FC64D	1	860	26.7	—	—	3.78
			2	1300	36.5	24.4	10.10	4.38
			2*	860	36.6	23.4	10.05	3.48
	MX12BN21	FC/MC43B	1	740	25.3	—	—	3.44
			2	1125	35.6	24.8	9.60	3.88
			2*	740	35.0	23.6	9.00	3.10
	MX12DN21	FC/MC48D	1	830	25.5	—	—	3.56
			2	1125	35.4	24.2	10.00	4.04
			2*	830	35.6	23.4	9.95	3.26
	MX12DN21	FC/MC60D	1	845	25.9	—	—	3.60
			2	1150	35.4	24.0	10.00	4.04
			2*	845	35.6	23.4	9.90	3.26
	MX12DN21	FC64D	1	880	26.7	—	—	3.84
			2	1175	36.0	24.2	10.20	4.30
			2*	880	36.4	23.2	10.20	3.54
HL8B048F4(C)	AHE60D	—	1	1160	34.2	—	—	3.54
			2	1565	47.5	31.8	10.00	3.94
			2*	1160	46.5	29.2	9.35	3.36
	AHV48D	—	1	1010	34.0	—	—	3.34
			2	1585	47.5	32.2	9.80	3.76
			2*	1010	45.5	29.2	9.00	3.10
	AHV60D	—	1	1000	33.8	—	—	3.40
			2	1570	48.0	32.0	9.85	3.86
			2*	1000	46.0	29.0	9.10	3.18
	MV16C	FC/MC48C	1	1035	34.0	—	—	3.36
			2	1625	48.0	32.4	9.85	3.84
			2*	1035	46.0	29.6	9.35	3.14
	MV16C	FC60C	1	1035	34.2	—	—	3.32
			2	1625	48.0	32.4	9.80	3.78
			2*	1035	46.0	29.6	9.35	3.10
	MV20D	FC/MC48D	1	1025	33.8	—	—	3.36
			2	1620	48.0	32.4	9.95	3.88
			2*	1025	46.0	29.6	9.45	3.14
	MV20D	FC/MC60D	1	1020	34.2	—	—	3.28
			2	1600	48.0	32.4	9.80	3.78
			2*	1020	46.0	29.6	9.10	3.06
	MV20D	FC/MC62D	1	1085	34.0	—	—	3.50
			2	1645	48.0	31.8	10.00	3.98
			2*	1085	46.0	29.0	9.60	3.30
	MV20D	FC64D	1	1075	34.4	—	—	3.62
			2	1630	48.5	32.2	10.05	4.06
			2*	1075	46.5	29.6	9.30	3.38
	MX16CN21	FC/MC48C	1	1015	33.8	—	—	3.40
			2	1600	48.0	32.6	9.80	3.82
			2*	1015	46.0	29.4	9.05	3.18

For notes, see Page 23.

HEATING CAPACITY - With Air Handler (Continued)

UNIT MODEL	AIR HANDLER MODEL	COIL ¹ MODEL	HEATING ²					
			STAGE	RATED CFM	NET MBH		HSPF	COP @ 47°F
					47°F OD	17°F OD		
18 SEER HP WITH AIR HANDLERS								
HL8B060F4(C)	MX16CN21	FC60C	1	1020	34.0	—	—	3.38
			2	1600	48.0	32.4	9.75	3.76
			2*	1020	46.0	29.4	9.05	3.12
	AHE60D	—	1	1160	41.0	—	—	3.18
			2	1835	58.0	38.0	9.35	3.78
			2*	1160	59.0	37.2	9.00	2.96
	AHV60D	—	1	1090	40.5	—	—	3.14
			2	1635	57.5	38.0	9.30	3.64
			2*	1090	58.5	37.0	9.15	2.90
	MV20D	FC/MC60D	1	1160	41.0	—	—	3.10
			2	1845	57.5	38.5	9.30	3.66
			2*	1160	58.5	37.6	8.95	2.86
	MV20D	FC/MC62D	1	1185	41.0	—	—	3.24
			2	1845	58.0	38.0	9.40	3.80
			2*	1185	59.0	37.0	9.20	3.00
MV20D	FC64D	1	1160	41.5	—	—	3.30	
		2	1855	58.5	38.5	9.35	3.86	
		2*	1160	59.5	37.6	9.25	3.06	

1. Rated CFM same as for cooling.

2. Heating MBH based on AHRI standards of 70°F DB (Dry Bulb) entering indoor air, 72% RH (Relative Humidity) outdoor air with 25 feet of interconnecting piping and no supplemental electric heat operation.

* Notates "Hot Heat Pump" performance. These ratings are not AHRI listed.

COP equals MBH output divided by (total KW input x 3.412).

HSPF (Heating Seasonal Performance Factor) is the total heating output during a normal annual usage period for heating divided by the total electric power input during the same period.

— = Not Applicable.

MA Modular Air Handlers use Coil Only Ratings.

HEATING CAPACITY - Upflow, Downflow, and Horizontal Furnaces and Coils (Coil Only Ratings)

UNIT MODEL	COIL ¹ MODEL	HEATING ²					
		STAGE	RATED CFM	NET MBH		HSPF	COP @ 47°F
				47°F OD	17°F OD		
18 SEER HP COIL ONLY RATINGS							
HL8B024F4(C)	FC/MC/PC48	1	600	19.70	—	—	3.24
		2	800	24.60	17.50	8.5	3.54
		2*	600	25.80	15.50	8.0	3.12
HL8B036F4(C)	FC/MC62	1	900	26.50	—	—	3.38
		2	1200	36.50	24.60	9.2	3.88
		2*	900	36.60	23.50	7.9	3.24
HL8B048F4(C)	FC/MC62	1	1200	35.20	—	—	3.32
		2	1600	48.50	32.60	9.6	3.76
		2*	1200	47.30	30.10	8.0	3.24
HL8B060F4(C)	FC/MC62	1	1350	42.50	—	—	3.14
		2	1800	58.50	38.50	9.2	3.66
		2*	1350	60.50	38.00	7.7	3.02

1. Rated CFM same as for cooling.

2. Heating MBH based on AHRI standards of 70°F DB (Dry Bulb) entering indoor air, 72% RH (Relative Humidity) outdoor air with 25 feet of interconnecting piping and no supplemental electric heat operation.

* Notates "Hot Heat Pump" performance. These ratings are not AHRI listed.

COP equals MBH output divided by (total KW input x 3.412).

HSPF (Heating Seasonal Performance Factor) is the total heating output during a normal annual usage period for heating divided by the total electric power input during the same period.

MA Modular Air Handlers use Coil Only Ratings.

PSC furnaces, such as the TG8S, TGLS, and TG9S, use Coil Only Ratings.

— = Not Applicable.

HEATING CAPACITY - With High Efficiency Motor Furnaces

UNIT MODEL	FURNACE MODEL	COIL ¹ MODEL	HEATING ²					
			STAGE	RATED CFM	NET MBH		HSPF	COP @ 47°F
					47°F OD	17°F OD		
18 SEER HP WITH HIGH EFFICIENCY MOTOR FURNACES³								
HL8B024F4(C)	T*(8,L)V*A12	FC/MC/PC37A	1	585	19.2	—	—	3.42
			2	765	23.8	17.0	9.50	3.70
			2*	585	25.4	15.2	9.00	3.22
	T*(8,L)V*B12	FC/MC/PC43B	1	515	19.2	—	—	3.24
			2	790	23.8	16.9	9.60	3.76
			2*	515	24.8	15.3	9.20	3.02
	T*(8,L)V*C16	FC/MC/PC43C	1	645	19.3	—	—	3.54
			2	770	23.8	16.9	9.70	3.76
			2*	645	25.6	15.2	9.50	3.36
	T*9V*A10	FC/MC/PC37A	1	570	19.2	—	—	3.34
			2	790	24.2	17.2	9.00	3.62
			2*	570	25.4	15.3	8.55	3.16
	T*9V*B12	FC/MC/PC43B	1	550	19.0	—	—	3.36
			2	800	24.0	17.0	9.45	3.76
			2*	550	25.2	15.2	8.85	3.16
	T*9V*C16	FC/MC/PC48C	1	635	19.1	—	—	3.58
			2	890	24.2	16.9	9.55	3.92
			2*	635	25.4	15.0	9.05	3.40
	T*9V*C16	FC/PC60C	1	635	19.2	—	—	3.60
			2	890	24.2	16.8	9.65	3.92
			2*	635	25.4	15.0	9.15	3.38
	T*9V*C16	UC48C	1	635	19.5	—	—	3.76
			2	890	24.2	16.8	9.65	4.04
			2*	635	25.8	15.0	9.25	3.58
	T*9V*C16	UC60C	1	635	19.2	—	—	3.60
			2	890	24.2	16.8	9.65	3.92
			2*	635	25.4	15.0	9.15	3.38
	T*9V*C20	FC/MC/PC43C	1	630	19.2	—	—	3.54
			2	890	24.2	16.9	9.60	3.90
			2*	630	25.2	15.1	9.05	3.34
	T*9V*C20	FC/MC/PC48C	1	630	19.1	—	—	3.58
			2	890	24.2	16.9	9.55	3.92
			2*	630	25.4	15.0	9.05	3.38
	T*9V*C20	UC48C	1	630	19.5	—	—	3.76
			2	890	24.2	16.8	9.65	4.04
			2*	630	25.8	15.0	9.25	3.58
	TM8X080C16MP11	FC/MC/PC43C	1	630	19.3	—	—	3.50
			2	800	24.2	17.2	9.10	3.66
			2*	630	25.4	15.2	8.80	3.30
	TM8X080C16MP11	FC/MC/PC48C	1	630	19.3	—	—	3.52
			2	800	24.2	17.1	9.10	3.70
			2*	630	25.4	15.1	8.85	3.34
	TM8X080C16MP11	FC/PC60C	1	630	19.3	—	—	3.54
			2	800	24.2	17.0	9.10	3.72
			2*	630	25.4	15.0	8.85	3.36
	TM8X080C16MP11	UC48C	1	630	19.5	—	—	3.70
			2	800	24.4	17.0	9.15	3.82
			2*	630	25.8	15.1	8.95	3.52
TM8X080C16MP11	UC60C	1	630	19.3	—	—	3.54	
		2	800	24.2	17.0	9.10	3.72	
		2*	630	25.4	15.0	8.85	3.36	

For notes, see Page 44.

HEATING CAPACITY - With High Efficiency Motor Furnaces (Continued)

UNIT MODEL	FURNACE MODEL	COIL ¹ MODEL	HEATING ²						
			STAGE	RATED CFM	NET MBH		HSPF	COP @ 47°F	
					47°F OD	17°F OD			
18 SEER HP WITH HIGH EFFICIENCY MOTOR FURNACES³									
HL8B024F4(C)	TM8X100C16MP11	FC/MC/PC43C	1	630	19.3	—	—	3.50	
			2	800	24.2	17.2	9.10	3.66	
			2*	630	25.4	15.2	8.80	3.30	
	TM8X100C16MP11	FC/MC/PC48C	1	630	19.3	—	—	3.52	
			2	800	24.2	17.1	9.10	3.70	
			2*	630	25.4	15.1	8.85	3.34	
	TM8X100C16MP11	FC/PC60C	1	630	19.3	—	—	3.54	
			2	800	24.2	17.0	9.10	3.72	
			2*	630	25.4	15.0	8.85	3.36	
	TM8X100C16MP11	UC48C	1	630	19.5	—	—	3.70	
			2	800	24.4	17.0	9.15	3.82	
			2*	630	25.8	15.1	8.95	3.52	
	TM8X100C16MP11	UC60C	1	630	19.3	—	—	3.54	
			2	800	24.2	17.0	9.10	3.72	
			2*	630	25.4	15.0	8.85	3.36	
	TMLX080C16MP11	FC/MC/PC43C	1	630	19.3	—	—	3.50	
			2	800	24.2	17.2	9.10	3.66	
			2*	630	25.4	15.2	8.80	3.30	
	TMLX080C16MP11	FC/MC/PC48C	1	630	19.3	—	—	3.52	
			2	800	24.2	17.1	9.10	3.70	
			2*	630	25.4	15.1	8.85	3.34	
	TMLX080C16MP11	FC/PC60C	1	630	19.3	—	—	3.54	
			2	800	24.2	17.0	9.10	3.72	
			2*	630	25.4	15.0	8.85	3.36	
	TMLX080C16MP11	UC48C	1	630	19.5	—	—	3.70	
			2	800	24.4	17.0	9.15	3.82	
			2*	630	25.8	15.1	8.95	3.52	
	TMLX080C16MP11	UC60C	1	630	19.3	—	—	3.54	
			2	800	24.2	17.0	9.10	3.72	
			2*	630	25.4	15.0	8.85	3.36	
	TMLX100C16MP11	FC/MC/PC43C	1	630	19.3	—	—	3.50	
			2	800	24.2	17.2	9.10	3.66	
			2*	630	25.4	15.2	8.80	3.30	
	TMLX100C16MP11	FC/MC/PC48C	1	630	19.3	—	—	3.52	
			2	800	24.2	17.1	9.10	3.70	
			2*	630	25.4	15.1	8.85	3.34	
	TMLX100C16MP11	FC/PC60C	1	630	19.3	—	—	3.54	
			2	800	24.2	17.0	9.10	3.72	
			2*	630	25.4	15.0	8.85	3.36	
	TMLX100C16MP11	UC48C	1	630	19.5	—	—	3.70	
			2	800	24.4	17.0	9.15	3.82	
			2*	630	25.8	15.1	8.95	3.52	
	TMLX100C16MP11	UC60C	1	630	19.3	—	—	3.54	
			2	800	24.2	17.0	9.10	3.72	
			2*	630	25.4	15.0	8.85	3.36	
	HL8B036F4(C)	T*(8,L)V*A12	FC/MC/PC37A	1	730	25.5	—	—	3.26
				2	1150	36.0	25.0	9.25	3.80
				2*	730	36.0	24.0	8.50	2.90
T*(8,L)V*B12		FC/MC/PC43B	1	860	26.3	—	—	3.48	
			2	1275	36.5	25.2	9.25	3.90	
			2*	860	36.2	24.0	9.20	3.18	

For notes, see Page 44.

HEATING CAPACITY - With High Efficiency Motor Furnaces (Continued)

UNIT MODEL	FURNACE MODEL	COIL ¹ MODEL	HEATING ²					
			STAGE	RATED CFM	NET MBH		HSPF	COP @ 47°F
					47°F OD	17°F OD		
18 SEER HP WITH HIGH EFFICIENCY MOTOR FURNACES³								
HL8B036F4(C)	T*(8,L)V*C16	FC/MC/PC43C	1	770	25.5	—	—	3.38
			2	1190	35.8	24.6	9.65	3.98
			2*	770	35.2	23.8	9.35	3.08
	T*(8,L)V*C16	FC/MC/PC48C	1	725	25.7	—	—	3.32
			2	1195	35.8	24.6	9.80	4.06
			2*	725	36.4	23.8	8.80	2.96
	T*(8,L)V*C16	FC/PC60C	1	710	25.9	—	—	3.36
			2	1185	35.4	24.2	9.80	3.96
			2*	710	35.6	23.4	9.60	2.96
	T*(8,L)V*C16	UC48C	1	810	26.7	—	—	3.68
			2	1210	36.0	24.6	9.90	4.18
			2*	810	36.8	23.6	9.25	3.36
	T*(8,L)V*C16	UC60C	1	810	25.5	—	—	3.34
			2	1195	35.6	23.6	9.75	3.96
			2*	810	35.2	22.8	9.55	3.10
	T*(8,L)V*C20	FC/MC/PC43C	1	740	25.3	—	—	3.34
			2	1190	35.8	24.6	9.70	3.98
			2*	740	35.6	23.8	8.85	3.00
	T*(8,L)V*C20	FC/MC/PC48C	1	715	25.5	—	—	3.32
			2	1150	35.6	24.6	9.80	4.02
			2*	715	35.8	23.8	9.80	2.98
	T*(8,L)V*C20	FC/PC60C	1	800	26.1	—	—	3.50
			2	1215	35.8	24.4	9.80	4.04
			2*	800	34.8	23.4	9.35	3.20
	T*(8,L)V*C20	UC48C	1	720	26.3	—	—	3.54
			2	1155	36.0	24.4	9.95	4.14
			2*	720	35.0	23.8	9.70	3.22
	T*(8,L)V*C20	UC60C	1	800	25.5	—	—	3.34
			2	1215	35.6	23.6	9.75	3.96
			2*	800	35.2	22.8	9.55	3.10
	T*9V*B12	FC/MC/PC43B	1	815	25.5	—	—	3.42
			2	1200	36.0	25.0	9.30	3.86
			2*	815	34.4	23.8	8.80	3.18
	T*9V*C16	FC/MC/PC43C	1	815	25.9	—	—	3.44
			2	1240	36.0	25.0	9.45	3.94
			2*	815	34.4	24.0	8.90	3.18
	T*9V*C16	FC/MC/PC48C	1	780	25.7	—	—	3.44
			2	1195	35.8	24.8	9.60	3.96
			2*	780	36.0	23.6	8.95	3.12
	T*9V*C16	FC/PC60C	1	810	26.3	—	—	3.48
			2	1235	36.0	24.8	9.55	3.96
			2*	810	36.0	23.6	8.85	3.12
T*9V*C16	UC48C	1	780	26.3	—	—	3.60	
		2	1195	36.0	24.6	9.70	4.06	
		2*	780	36.4	23.8	9.10	3.28	
T*9V*C16	UC60C	1	810	25.7	—	—	3.36	
		2	1235	36.0	24.2	9.50	3.94	
		2*	810	35.6	23.0	9.45	3.10	
T*9V*C20	FC/MC/PC43C	1	780	25.3	—	—	3.40	
		2	1200	35.8	24.8	9.60	3.96	
		2*	780	35.8	23.8	8.85	3.06	

For notes, see Page 44.

HEATING CAPACITY - With High Efficiency Motor Furnaces (Continued)

UNIT MODEL	FURNACE MODEL	COIL ¹ MODEL	HEATING ²					
			STAGE	RATED CFM	NET MBH		HSPF	COP @ 47°F
					47°F OD	17°F OD		
18 SEER HP WITH HIGH EFFICIENCY MOTOR FURNACES³								
HL8B036F4(C)	T*9V*C20	FC/MC/PC48C	1	745	25.9	—	—	3.38
			2	1330	36.5	25.0	9.55	4.06
			2*	745	35.6	23.8	8.65	3.04
	T*9V*C20	FC/PC60C	1	770	26.1	—	—	3.44
			2	1330	36.5	24.8	9.55	4.04
			2*	770	36.0	23.6	8.65	3.04
	T*9V*C20	UC48C	1	755	26.7	—	—	3.56
			2	1330	37.0	25.0	9.60	4.14
			2*	755	36.8	24.0	8.85	3.24
	T*9V*C20	UC60C	1	770	25.7	—	—	3.30
			2	1330	36.5	24.4	9.55	4.02
			2*	770	35.8	23.0	8.65	3.02
	T*9V*D20	FC/MC/PC48D	1	830	25.9	—	—	3.52
			2	1240	36.0	24.8	9.75	4.08
			2*	830	36.0	23.8	9.70	3.22
	T*9V*D20	FC/MC/PC60D	1	830	26.1	—	—	3.54
			2	1225	35.8	24.6	9.70	4.02
			2*	830	35.8	23.6	9.60	3.18
	T*9V*D20	FC/MC62D	1	835	25.9	—	—	3.54
			2	1235	36.0	24.2	9.80	4.12
			2*	835	36.0	23.2	9.70	3.28
	T*9V*D20	FC64D	1	835	26.7	—	—	3.72
			2	1235	36.5	24.6	9.90	4.26
			2*	835	36.4	23.4	9.85	3.42
	T*9V*D20	UC48D	1	830	26.7	—	—	3.70
			2	1240	36.5	24.6	9.85	4.18
			2*	830	36.8	23.6	9.25	3.40
	T*9V*D20	UC60D	1	830	25.7	—	—	3.40
			2	1225	35.8	24.0	9.70	3.98
			2*	830	34.6	23.0	9.20	3.20
	TM8X060A12MP11	FC/MC/PC37A	1	770	25.5	—	—	3.38
			2	1125	35.8	25.0	9.30	3.80
			2*	770	35.2	23.8	8.75	3.08
	TM8X080B12MP11	FC/MC/PC43B	1	805	25.5	—	—	3.38
			2	1175	35.8	25.0	9.35	3.80
			2*	805	35.2	23.8	8.80	3.08
	TM8X080C16MP11	FC/MC/PC43C	1	775	25.3	—	—	3.42
			2	1150	35.6	24.6	9.70	3.90
			2*	775	35.2	23.6	9.00	3.10
	TM8X080C16MP11	FC/MC/PC48C	1	775	25.7	—	—	3.50
			2	1150	35.8	24.6	9.75	4.00
			2*	775	35.8	23.6	9.05	3.14
	TM8X080C16MP11	FC/MC/PC48D	1	805	25.7	—	—	3.50
			2	1175	35.8	24.6	9.80	4.00
			2*	805	35.8	23.6	9.05	3.14
	TM8X080C16MP11	FC/MC/PC60D	1	800	25.9	—	—	3.54
			2	1175	35.6	24.4	9.75	4.00
			2*	800	34.6	23.4	9.70	3.24
TM8X080C16MP11	FC/MC62D	1	785	25.5	—	—	3.54	
		2	1175	35.8	23.8	9.85	4.08	
		2*	785	35.6	22.8	9.10	3.22	

For notes, see Page 44.

HEATING CAPACITY - With High Efficiency Motor Furnaces (Continued)

UNIT MODEL	FURNACE MODEL	COIL ¹ MODEL	HEATING ²					
			STAGE	RATED CFM	NET MBH		HSPF	COP @ 47°F
					47°F OD	17°F OD		
18 SEER HP WITH HIGH EFFICIENCY MOTOR FURNACES³								
HL8B036F4(C)	TM8X080C16MP11	FC/PC60C	1	790	25.9	—	—	3.52
			2	1175	35.6	24.4	9.75	3.98
			2*	790	35.6	23.4	9.05	3.14
	TM8X080C16MP11	FC64D	1	795	26.3	—	—	3.68
			2	1175	36.0	24.4	9.95	4.18
			2*	795	36.2	23.4	9.20	3.32
	TM8X080C16MP11	UC48C	1	775	26.3	—	—	3.66
			2	1150	36.0	24.6	9.85	4.12
			2*	775	36.4	23.6	9.20	3.32
	TM8X080C16MP11	UC48D	1	805	26.3	—	—	3.64
			2	1175	36.0	24.4	9.85	4.12
			2*	805	36.4	23.6	9.25	3.30
	TM8X080C16MP11	UC60C	1	790	25.3	—	—	3.38
			2	1175	35.6	23.8	9.70	3.96
			2*	790	35.0	22.8	9.05	3.12
	TM8X080C16MP11	UC60D	1	800	25.3	—	—	3.38
			2	1175	35.6	23.8	9.75	3.96
			2*	800	35.0	22.8	9.05	3.12
	TM8X100C16MP11	FC/MC/PC43C	1	775	25.3	—	—	3.42
			2	1150	35.6	24.6	9.70	3.90
			2*	775	35.2	23.6	9.00	3.10
	TM8X100C16MP11	FC/MC/PC48C	1	775	25.7	—	—	3.50
			2	1150	35.8	24.6	9.75	4.00
			2*	775	35.8	23.6	9.05	3.14
	TM8X100C16MP11	FC/MC/PC48D	1	805	25.7	—	—	3.50
			2	1175	35.8	24.6	9.80	4.00
			2*	805	35.8	23.6	9.05	3.14
	TM8X100C16MP11	FC/MC/PC60D	1	800	25.9	—	—	3.54
			2	1175	35.6	24.4	9.75	4.00
			2*	800	34.6	23.4	9.70	3.24
	TM8X100C16MP11	FC/MC62D	1	785	25.5	—	—	3.54
			2	1175	35.8	23.8	9.85	4.08
			2*	785	35.6	22.8	9.10	3.22
	TM8X100C16MP11	FC/PC60C	1	790	25.9	—	—	3.52
			2	1175	35.6	24.4	9.75	3.98
			2*	790	35.6	23.4	9.05	3.14
	TM8X100C16MP11	FC64D	1	795	26.3	—	—	3.68
			2	1175	36.0	24.4	9.95	4.18
			2*	795	36.2	23.4	9.20	3.32
	TM8X100C16MP11	UC48C	1	775	26.3	—	—	3.66
			2	1150	36.0	24.6	9.85	4.12
			2*	775	36.4	23.6	9.20	3.32
TM8X100C16MP11	UC48D	1	805	26.3	—	—	3.64	
		2	1175	36.0	24.4	9.85	4.12	
		2*	805	36.4	23.6	9.25	3.30	
TM8X100C16MP11	UC60C	1	790	25.3	—	—	3.38	
		2	1175	35.6	23.8	9.70	3.96	
		2*	790	35.0	22.8	9.05	3.12	
TM8X100C16MP11	UC60D	1	800	25.3	—	—	3.38	
		2	1175	35.6	23.8	9.75	3.96	
		2*	800	35.0	22.8	9.05	3.12	

For notes, see Page 44.

HEATING CAPACITY - With High Efficiency Motor Furnaces (Continued)

UNIT MODEL	FURNACE MODEL	COIL ¹ MODEL	HEATING ²					
			STAGE	RATED CFM	NET MBH		HSPF	COP @ 47°F
					47°F OD	17°F OD		
18 SEER HP WITH HIGH EFFICIENCY MOTOR FURNACES³								
HL8B036F4(C)	TMLX060A12MP11	FC/MC/PC37A	1	770	25.5	—	—	3.38
			2	1125	35.8	25.0	9.30	3.80
			2*	770	35.2	23.8	8.75	3.08
	TMLX080B12MP11	FC/MC/PC43B	1	805	25.5	—	—	3.38
			2	1175	35.8	25.0	9.35	3.80
			2*	805	35.2	23.8	8.80	3.08
	TMLX080C16MP11	FC/MC/PC43C	1	775	25.3	—	—	3.42
			2	1150	35.6	24.6	9.70	3.90
			2*	775	35.2	23.6	9.00	3.10
	TMLX080C16MP11	FC/MC/PC48C	1	775	25.7	—	—	3.50
			2	1150	35.8	24.6	9.75	4.00
			2*	775	35.8	23.6	9.05	3.14
	TMLX080C16MP11	FC/MC/PC48D	1	805	25.7	—	—	3.50
			2	1175	35.8	24.6	9.80	4.00
			2*	805	35.8	23.6	9.05	3.14
	TMLX080C16MP11	FC/MC/PC60D	1	800	25.9	—	—	3.54
			2	1175	35.6	24.4	9.75	4.00
			2*	800	34.6	23.4	9.70	3.24
	TMLX080C16MP11	FC/MC62D	1	785	25.5	—	—	3.54
			2	1175	35.8	23.8	9.85	4.08
			2*	785	35.6	22.8	9.10	3.22
	TMLX080C16MP11	FC/PC60C	1	790	25.9	—	—	3.52
			2	1175	35.6	24.4	9.75	3.98
			2*	790	35.6	23.4	9.05	3.14
	TMLX080C16MP11	FC64D	1	795	26.3	—	—	3.68
			2	1175	36.0	24.4	9.95	4.18
			2*	795	36.2	23.4	9.20	3.32
	TMLX080C16MP11	UC48C	1	775	26.3	—	—	3.66
			2	1150	36.0	24.6	9.85	4.12
			2*	775	36.4	23.6	9.20	3.32
	TMLX080C16MP11	UC48D	1	805	26.3	—	—	3.64
			2	1175	36.0	24.4	9.85	4.12
			2*	805	36.4	23.6	9.25	3.30
	TMLX080C16MP11	UC60C	1	790	25.3	—	—	3.38
			2	1175	35.6	23.8	9.70	3.96
			2*	790	35.0	22.8	9.05	3.12
	TMLX080C16MP11	UC60D	1	800	25.3	—	—	3.38
			2	1175	35.6	23.8	9.75	3.96
			2*	800	35.0	22.8	9.05	3.12
	TMLX100C16MP11	FC/MC/PC43C	1	775	25.3	—	—	3.42
			2	1150	35.6	24.6	9.70	3.90
			2*	775	35.2	23.6	9.00	3.10
	TMLX100C16MP11	FC/MC/PC48C	1	775	25.7	—	—	3.50
			2	1150	35.8	24.6	9.75	4.00
			2*	775	35.8	23.6	9.05	3.14
	TMLX100C16MP11	FC/MC/PC48D	1	805	25.7	—	—	3.50
			2	1175	35.8	24.6	9.80	4.00
			2*	805	35.8	23.6	9.05	3.14
TMLX100C16MP11	FC/MC/PC60D	1	800	25.9	—	—	3.54	
		2	1175	35.6	24.4	9.75	4.00	
		2*	800	34.6	23.4	9.70	3.24	

For notes, see Page 44.

HEATING CAPACITY - With High Efficiency Motor Furnaces (Continued)

UNIT MODEL	FURNACE MODEL	COIL ¹ MODEL	HEATING ²					
			STAGE	RATED CFM	NET MBH		HSPF	COP @ 47°F
					47°F OD	17°F OD		
18 SEER HP WITH HIGH EFFICIENCY MOTOR FURNACES³								
HL8B036F4(C)	TMLX100C16MP11	FC/MC62D	1	785	25.5	—	—	3.54
			2	1175	35.8	23.8	9.85	4.08
			2*	785	35.6	22.8	9.10	3.22
	TMLX100C16MP11	FC/PC60C	1	790	25.9	—	—	3.52
			2	1175	35.6	24.4	9.75	3.98
			2*	790	35.6	23.4	9.05	3.14
	TMLX100C16MP11	FC64D	1	795	26.3	—	—	3.68
			2	1175	36.0	24.4	9.95	4.18
			2*	795	36.2	23.4	9.20	3.32
	TMLX100C16MP11	UC48C	1	775	26.3	—	—	3.66
			2	1150	36.0	24.6	9.85	4.12
			2*	775	36.4	23.6	9.20	3.32
	TMLX100C16MP11	UC48D	1	805	26.3	—	—	3.64
			2	1175	36.0	24.4	9.85	4.12
			2*	805	36.4	23.6	9.25	3.30
	TMLX100C16MP11	UC60C	1	790	25.3	—	—	3.38
			2	1175	35.6	23.8	9.70	3.96
			2*	790	35.0	22.8	9.05	3.12
	TMLX100C16MP11	UC60D	1	800	25.3	—	—	3.38
			2	1175	35.6	23.8	9.75	3.96
			2*	800	35.0	22.8	9.05	3.12
	TM9E060B12MP11	FC/MC/PC43B	1	730	25.3	—	—	3.32
			2	1125	35.8	25.0	9.35	3.80
			2*	730	35.8	23.8	8.60	2.94
	TM9E080B12MP11	FC/MC/PC43B	1	730	25.3	—	—	3.32
			2	1125	35.8	25.0	9.35	3.80
			2*	730	35.8	23.8	8.60	2.94
	TM9E080C16MP11	FC/MC/PC48D	1	775	25.7	—	—	3.48
			2	1175	35.8	24.8	9.60	3.96
			2*	775	35.8	23.6	8.95	3.14
	TM9E080C16MP11	FC/MC62D	1	765	25.3	—	—	3.50
			2	1175	36.0	24.0	9.70	4.04
			2*	765	35.6	22.8	8.95	3.14
	TM9E080C16MP11	FC64D	1	775	26.3	—	—	3.66
			2	1175	36.5	24.6	9.80	4.14
			2*	775	36.4	23.4	9.15	3.30
	TM9E080C16MP11	UC48D	1	775	26.3	—	—	3.64
			2	1175	36.0	24.6	9.70	4.06
			2*	775	36.4	23.6	9.10	3.30
	TM9E100C16MP11	FC/MC/PC48D	1	775	25.7	—	—	3.48
			2	1175	35.8	24.8	9.60	3.96
			2*	775	35.8	23.6	8.95	3.14
TM9E100C16MP11	FC/MC62D	1	765	25.3	—	—	3.50	
		2	1175	36.0	24.0	9.70	4.04	
		2*	765	35.6	22.8	8.95	3.14	
TM9E100C16MP11	FC64D	1	775	26.3	—	—	3.66	
		2	1175	36.5	24.6	9.80	4.14	
		2*	775	36.4	23.4	9.15	3.30	
TM9E100C16MP11	UC48D	1	775	26.3	—	—	3.64	
		2	1175	36.0	24.6	9.70	4.06	
		2*	775	36.4	23.6	9.10	3.30	

For notes, see Page 44.

HEATING CAPACITY - With High Efficiency Motor Furnaces (Continued)

UNIT MODEL	FURNACE MODEL	COIL ¹ MODEL	HEATING ²						
			STAGE	RATED CFM	NET MBH		HSPF	COP @ 47°F	
					47°F OD	17°F OD			
18 SEER HP WITH HIGH EFFICIENCY MOTOR FURNACES³									
HL8B036F4(C)	TM9X060B12MP11	FC/MC/PC43B	1	730	25.3	—	—	3.32	
			2	1125	35.8	25.0	9.35	3.80	
			2*	730	35.8	23.8	8.60	2.94	
	TM9X080B12MP11	FC/MC/PC43B	1	730	25.3	—	—	3.32	
			2	1125	35.8	25.0	9.35	3.80	
			2*	730	35.8	23.8	8.60	2.94	
	TM9X080C16MP11	FC/MC/PC48D	1	775	25.7	—	—	3.48	
			2	1175	35.8	24.8	9.60	3.96	
			2*	775	35.8	23.6	8.95	3.14	
	TM9X080C16MP11	FC/MC62D	1	765	25.3	—	—	3.50	
			2	1175	36.0	24.0	9.70	4.04	
			2*	765	35.6	22.8	8.95	3.14	
	TM9X080C16MP11	FC64D	1	775	26.3	—	—	3.66	
			2	1175	36.5	24.6	9.80	4.14	
			2*	775	36.4	23.4	9.15	3.30	
	TM9X080C16MP11	UC48D	1	775	26.3	—	—	3.64	
			2	1175	36.0	24.6	9.70	4.06	
			2*	775	36.4	23.6	9.10	3.30	
	TM9X100C16MP11	FC/MC/PC48D	1	775	25.7	—	—	3.48	
			2	1175	35.8	24.8	9.60	3.96	
			2*	775	35.8	23.6	8.95	3.14	
	TM9X100C16MP11	FC/MC62D	1	765	25.3	—	—	3.50	
			2	1175	36.0	24.0	9.70	4.04	
			2*	765	35.6	22.8	8.95	3.14	
	TM9X100C16MP11	FC64D	1	775	26.3	—	—	3.66	
			2	1175	36.5	24.6	9.80	4.14	
			2*	775	36.4	23.4	9.15	3.30	
	TM9X100C16MP11	UC48D	1	775	26.3	—	—	3.64	
			2	1175	36.0	24.6	9.70	4.06	
			2*	775	36.4	23.6	9.10	3.30	
	HL8B048F4(C)	T*(8,L)V*C16	FC/MC/PC48C	1	1120	34.4	—	—	3.38
				2	1565	48.5	33.0	9.55	3.68
				2*	1120	46.5	30.0	9.05	3.22
		T*(8,L)V*C16	FC/MC/PC48D	1	1120	34.4	—	—	3.38
				2	1565	48.5	33.0	9.55	3.68
				2*	1120	46.5	30.0	9.05	3.22
T*(8,L)V*C16		FC/MC/PC60D	1	1025	34.2	—	—	3.28	
			2	1600	48.0	32.6	9.60	3.70	
			2*	1025	46.0	29.6	9.10	3.08	
T*(8,L)V*C16		FC/MC62D	1	1025	34.0	—	—	3.38	
			2	1635	48.5	32.2	9.80	3.86	
			2*	1025	46.0	29.0	9.25	3.16	
T*(8,L)V*C16		FC/PC60C	1	1025	34.2	—	—	3.28	
			2	1600	48.0	32.6	9.60	3.70	
			2*	1025	46.0	29.6	9.10	3.08	
T*(8,L)V*C16		FC64D	1	1025	34.6	—	—	3.54	
			2	1635	48.5	32.6	9.90	3.96	
			2*	1025	47.0	29.8	9.45	3.34	
T*(8,L)V*C16		UC48C	1	1035	34.8	—	—	3.46	
			2	1615	48.5	32.6	9.75	3.84	
			2*	1035	47.0	29.8	9.40	3.26	

For notes, see Page 44.

HEATING CAPACITY - With High Efficiency Motor Furnaces (Continued)

UNIT MODEL	FURNACE MODEL	COIL ¹ MODEL	HEATING ²					
			STAGE	RATED CFM	NET MBH		HSPF	COP @ 47°F
					47°F OD	17°F OD		
18 SEER HP WITH HIGH EFFICIENCY MOTOR FURNACES³								
HL8B048F4(C)	T*(8,L)V*C16	UC60C	1	1035	33.6	—	—	3.24
			2	1625	48.0	32.0	9.65	3.72
			2*	1035	46.0	29.2	9.25	3.08
	T*(8,L)V*C20	FC/MC/PC48C	1	1080	34.0	—	—	3.32
			2	1640	48.5	32.8	9.70	3.76
			2*	1080	46.0	29.8	9.20	3.12
	T*(8,L)V*C20	FC/MC/PC48D	1	1080	34.0	—	—	3.32
			2	1640	48.5	32.8	9.70	3.76
			2*	1080	46.0	29.8	9.20	3.12
	T*(8,L)V*C20	FC/MC/PC60D	1	1060	34.2	—	—	3.28
			2	1625	48.0	32.6	9.65	3.72
			2*	1060	46.0	29.6	9.10	3.08
	T*(8,L)V*C20	FC/MC62D	1	1060	34.2	—	—	3.40
			2	1620	48.0	32.2	9.85	3.88
			2*	1060	46.0	29.2	9.20	3.22
	T*(8,L)V*C20	FC/PC60C	1	1060	34.2	—	—	3.28
			2	1625	48.0	32.6	9.65	3.72
			2*	1060	46.0	29.6	9.10	3.08
	T*(8,L)V*C20	FC64D	1	1060	34.8	—	—	3.52
			2	1630	48.5	32.4	9.95	4.00
			2*	1060	47.0	29.8	9.40	3.34
	T*(8,L)V*C20	UC48C	1	1080	35.0	—	—	3.48
			2	1640	48.5	32.6	9.75	3.84
			2*	1080	47.0	30.0	9.30	3.30
	T*(8,L)V*C20	UC60C	1	1015	33.6	—	—	3.22
			2	1605	48.0	31.8	9.75	3.74
			2*	1015	46.0	29.0	9.35	3.04
	T*9V*C16	FC/MC/PC48C	1	1050	34.0	—	—	3.30
			2	1590	48.5	32.8	9.65	3.74
			2*	1050	46.5	29.8	9.05	3.10
	T*9V*C16	FC/MC/PC48D	1	1050	34.0	—	—	3.30
			2	1590	48.5	32.8	9.65	3.74
			2*	1050	46.5	29.8	9.05	3.10
	T*9V*C16	FC/MC/PC60D	1	1050	34.4	—	—	3.28
			2	1590	48.0	32.8	9.60	3.68
			2*	1050	46.0	29.6	9.05	3.06
	T*9V*C16	FC/MC62D	1	1040	34.2	—	—	3.38
			2	1590	48.5	32.4	9.75	3.80
			2*	1040	46.0	29.2	9.15	3.18
	T*9V*C16	FC/PC60C	1	1050	34.4	—	—	3.28
			2	1590	48.0	32.8	9.60	3.68
			2*	1050	46.0	29.6	9.05	3.06
	T*9V*C16	FC64D	1	1040	34.8	—	—	3.52
			2	1590	49.0	32.6	9.85	3.94
			2*	1040	47.0	30.0	9.35	3.32
	T*9V*C16	UC48C	1	1050	34.8	—	—	3.42
			2	1590	48.5	32.8	9.65	3.74
			2*	1050	46.5	30.0	9.20	3.22
T*9V*C16	UC60C	1	1050	33.8	—	—	3.18	
		2	1590	48.0	32.0	9.55	3.60	
		2*	1050	46.0	29.2	9.05	3.02	

For notes, see Page 44.

HEATING CAPACITY - With High Efficiency Motor Furnaces (Continued)

UNIT MODEL	FURNACE MODEL	COIL ¹ MODEL	HEATING ²					
			STAGE	RATED CFM	NET MBH		HSPF	COP @ 47°F
					47°F OD	17°F OD		
18 SEER HP WITH HIGH EFFICIENCY MOTOR FURNACES³								
HL8B048F4(C)	T*9V*C20	FC/MC/PC48C	1	1055	34.0	—	—	3.32
			2	1655	48.5	32.8	9.65	3.74
			2*	1055	46.0	29.8	9.15	3.12
	T*9V*C20	FC/MC/PC48D	1	1055	34.0	—	—	3.32
			2	1655	48.5	32.8	9.65	3.74
			2*	1055	46.0	29.8	9.15	3.12
	T*9V*C20	FC/MC/PC60D	1	1055	34.2	—	—	3.28
			2	1655	48.0	32.8	9.60	3.68
			2*	1055	46.0	29.6	9.10	3.08
	T*9V*C20	FC/MC62D	1	1040	34.0	—	—	3.38
			2	1655	48.5	32.6	9.65	3.80
			2*	1040	46.5	29.2	9.20	3.18
	T*9V*C20	FC/PC60C	1	1055	34.2	—	—	3.28
			2	1655	48.0	32.8	9.60	3.68
			2*	1055	46.0	29.6	9.10	3.08
	T*9V*C20	FC64D	1	1040	34.8	—	—	3.52
			2	1655	49.0	32.8	9.75	3.90
			2*	1040	47.0	30.0	9.35	3.32
	T*9V*C20	UC48C	1	1055	35.0	—	—	3.46
			2	1655	48.5	32.6	9.70	3.84
			2*	1055	47.0	30.0	9.35	3.28
	T*9V*C20	UC60C	1	1055	34.0	—	—	3.24
			2	1655	48.0	32.2	9.60	3.70
			2*	1055	46.5	29.0	9.15	3.08
	T*9V*D20	FC/MC/PC48D	1	1060	34.0	—	—	3.30
			2	1645	48.5	32.8	9.65	3.74
			2*	1060	46.0	29.8	9.10	3.10
	T*9V*D20	FC/MC/PC60D	1	1070	34.4	—	—	3.28
			2	1615	48.0	32.6	9.65	3.70
			2*	1070	46.0	29.6	9.10	3.06
	T*9V*D20	FC/MC62D	1	1085	34.2	—	—	3.42
			2	1630	48.5	32.4	9.75	3.82
			2*	1085	46.5	29.4	9.10	3.24
	T*9V*D20	FC64D	1	1085	34.8	—	—	3.50
			2	1630	49.0	32.6	9.80	3.94
			2*	1085	47.0	30.0	9.30	3.32
	T*9V*D20	UC48D	1	1060	35.0	—	—	3.46
			2	1645	48.5	32.6	9.70	3.84
			2*	1060	47.0	30.2	9.35	3.28
	T*9V*D20	UC60D	1	1070	33.8	—	—	3.26
			2	1615	48.0	32.0	9.65	3.70
			2*	1070	46.5	29.0	9.15	3.10
	TM8X080C16MP11	FC/MC/PC48C	1	1030	33.8	—	—	3.36
			2	1525	48.0	32.8	9.65	3.70
			2*	1030	46.0	29.6	9.00	3.14
	TM8X080C16MP11	FC/MC/PC48D	1	1045	33.8	—	—	3.36
			2	1550	48.0	32.8	9.70	3.78
			2*	1045	46.0	29.6	9.00	3.14
TM8X080C16MP11	FC/MC/PC60D	1	1045	34.2	—	—	3.34	
		2	1550	48.0	32.6	9.65	3.72	
		2*	1045	46.0	29.6	8.95	3.10	

For notes, see Page 44.

HEATING CAPACITY - With High Efficiency Motor Furnaces (Continued)

UNIT MODEL	FURNACE MODEL	COIL ¹ MODEL	HEATING ²					
			STAGE	RATED CFM	NET MBH		HSPF	COP @ 47°F
					47°F OD	17°F OD		
18 SEER HP WITH HIGH EFFICIENCY MOTOR FURNACES³								
HL8B048F4(C)	TM8X080C16MP11	FC/MC62D	1	1040	33.8	—	—	3.42
			2	1550	48.0	32.2	9.70	3.78
			2*	1040	46.0	29.0	9.05	3.22
	TM8X080C16MP11	FC/PC60C	1	1020	34.0	—	—	3.32
			2	1525	48.0	32.4	9.60	3.62
			2*	1020	46.0	29.6	8.95	3.08
	TM8X080C16MP11	FC64D	1	1045	34.6	—	—	3.58
			2	1550	48.5	32.6	9.85	3.96
			2*	1045	46.5	29.8	9.20	3.36
	TM8X080C16MP11	UC48C	1	1030	34.6	—	—	3.48
			2	1525	48.5	32.6	9.70	3.78
			2*	1030	46.5	29.8	9.15	3.28
	TM8X080C16MP11	UC48D	1	1045	34.6	—	—	3.48
			2	1550	48.0	32.6	9.70	3.78
			2*	1045	46.5	29.8	9.15	3.28
	TM8X080C16MP11	UC60C	1	1020	33.6	—	—	3.24
			2	1525	48.0	32.0	9.55	3.62
			2*	1020	46.0	29.0	8.90	3.06
	TM8X080C16MP11	UC60D	1	1045	33.6	—	—	3.24
			2	1550	48.0	32.0	9.60	3.62
			2*	1045	46.0	29.0	8.95	3.06
	TM8X100C16MP11	FC/MC/PC48C	1	1030	33.8	—	—	3.36
			2	1525	48.0	32.8	9.65	3.70
			2*	1030	46.0	29.6	9.00	3.14
	TM8X100C16MP11	FC/MC/PC48D	1	1045	33.8	—	—	3.36
			2	1550	48.0	32.8	9.70	3.78
			2*	1045	46.0	29.6	9.00	3.14
	TM8X100C16MP11	FC/MC/PC60D	1	1045	34.2	—	—	3.34
			2	1550	48.0	32.6	9.65	3.72
			2*	1045	46.0	29.6	8.95	3.10
	TM8X100C16MP11	FC/MC62D	1	1040	33.8	—	—	3.42
			2	1550	48.0	32.2	9.70	3.78
			2*	1040	46.0	29.0	9.05	3.22
	TM8X100C16MP11	FC/PC60C	1	1020	34.0	—	—	3.32
			2	1525	48.0	32.4	9.60	3.62
			2*	1020	46.0	29.6	8.95	3.08
	TM8X100C16MP11	FC64D	1	1045	34.6	—	—	3.58
			2	1550	48.5	32.6	9.85	3.96
			2*	1045	46.5	29.8	9.20	3.36
	TM8X100C16MP11	UC48C	1	1030	34.6	—	—	3.48
			2	1525	48.5	32.6	9.70	3.78
			2*	1030	46.5	29.8	9.15	3.28
	TM8X100C16MP11	UC48D	1	1045	34.6	—	—	3.48
			2	1550	48.0	32.6	9.70	3.78
			2*	1045	46.5	29.8	9.15	3.28
	TM8X100C16MP11	UC60C	1	1020	33.6	—	—	3.24
			2	1525	48.0	32.0	9.55	3.62
			2*	1020	46.0	29.0	8.90	3.06
TM8X100C16MP11	UC60D	1	1045	33.6	—	—	3.24	
		2	1550	48.0	32.0	9.60	3.62	
		2*	1045	46.0	29.0	8.95	3.06	

For notes, see Page 44.

HEATING CAPACITY - With High Efficiency Motor Furnaces (Continued)

UNIT MODEL	FURNACE MODEL	COIL ¹ MODEL	HEATING ²					
			STAGE	RATED CFM	NET MBH		HSPF	COP @ 47°F
					47°F OD	17°F OD		
18 SEER HP WITH HIGH EFFICIENCY MOTOR FURNACES³								
HL8B048F4(C)	TM8X100C20MP11	FC/MC/PC48C	1	1090	34.2	—	—	3.42
			2	1550	48.0	32.6	9.70	3.74
			2*	1090	46.0	29.8	9.25	3.20
	TM8X100C20MP11	FC/MC/PC48D	1	1105	34.2	—	—	3.44
			2	1575	48.0	32.6	9.75	3.76
			2*	1105	46.0	29.8	9.30	3.22
	TM8X100C20MP11	FC/MC/PC60D	1	1105	34.2	—	—	3.40
			2	1575	48.0	32.2	9.70	3.72
			2*	1105	46.0	29.6	9.25	3.18
	TM8X100C20MP11	FC/MC62D	1	1100	34.0	—	—	3.48
			2	1575	48.0	32.2	9.80	3.82
			2*	1100	46.0	29.2	9.35	3.28
	TM8X100C20MP11	FC/PC60C	1	1085	34.2	—	—	3.32
			2	1550	48.0	32.4	9.70	3.74
			2*	1085	46.0	29.6	9.25	3.08
	TM8X100C20MP11	UC48C	1	1090	34.8	—	—	3.54
			2	1550	48.0	32.6	9.80	3.84
			2*	1090	47.0	30.0	9.50	3.34
	TM8X100C20MP11	UC48D	1	1105	34.8	—	—	3.56
			2	1575	48.0	32.6	9.80	3.86
			2*	1105	47.0	29.8	9.25	3.36
	TM8X100C20MP11	UC60C	1	1085	33.6	—	—	3.32
			2	1550	47.5	31.8	9.65	3.68
			2*	1085	46.0	29.0	9.30	3.14
	TM8X100C20MP11	UC60D	1	1105	33.8	—	—	3.34
			2	1575	48.0	31.8	9.70	3.70
			2*	1105	46.0	29.2	9.30	3.16
	TM8X120C20MP11	FC/MC/PC48C	1	1090	34.2	—	—	3.42
			2	1550	48.0	32.6	9.70	3.74
			2*	1090	46.0	29.8	9.25	3.20
	TM8X120C20MP11	FC/MC/PC48D	1	1105	34.2	—	—	3.44
			2	1575	48.0	32.6	9.75	3.76
			2*	1105	46.0	29.8	9.30	3.22
	TM8X120C20MP11	FC/MC/PC60D	1	1105	34.2	—	—	3.40
			2	1575	48.0	32.2	9.70	3.72
			2*	1105	46.0	29.6	9.25	3.18
	TM8X120C20MP11	FC/MC62D	1	1100	34.0	—	—	3.48
			2	1575	48.0	32.2	9.80	3.82
			2*	1100	46.0	29.2	9.35	3.28
	TM8X120C20MP11	FC/PC60C	1	1085	34.2	—	—	3.32
			2	1550	48.0	32.4	9.70	3.74
			2*	1085	46.0	29.6	9.25	3.08
	TM8X120C20MP11	UC48C	1	1090	34.8	—	—	3.54
			2	1550	48.0	32.6	9.80	3.84
			2*	1090	47.0	30.0	9.50	3.34
	TM8X120C20MP11	UC48D	1	1105	34.8	—	—	3.56
			2	1575	48.0	32.6	9.80	3.86
			2*	1105	47.0	29.8	9.25	3.36
	TM8X120C20MP11	UC60C	1	1085	33.6	—	—	3.32
			2	1550	47.5	31.8	9.65	3.68
			2*	1085	46.0	29.0	9.30	3.14

For notes, see Page 44.

HEATING CAPACITY - With High Efficiency Motor Furnaces (Continued)

UNIT MODEL	FURNACE MODEL	COIL ¹ MODEL	HEATING ²					
			STAGE	RATED CFM	NET MBH		HSPF	COP @ 47°F
					47°F OD	17°F OD		
18 SEER HP WITH HIGH EFFICIENCY MOTOR FURNACES³								
HL8B048F4(C)	TM8X120C20MP11	UC60D	1	1105	33.8	—	—	3.34
			2	1575	48.0	31.8	9.70	3.70
			2*	1105	46.0	29.2	9.30	3.16
	TMLX080C16MP11	FC/MC/PC48C	1	1030	33.8	—	—	3.36
			2	1525	48.0	32.8	9.65	3.70
			2*	1030	46.0	29.6	9.00	3.14
	TMLX080C16MP11	FC/MC/PC48D	1	1045	33.8	—	—	3.36
			2	1550	48.0	32.8	9.70	3.78
			2*	1045	46.0	29.6	9.00	3.14
	TMLX080C16MP11	FC/MC/PC60D	1	1045	34.2	—	—	3.34
			2	1550	48.0	32.6	9.65	3.72
			2*	1045	46.0	29.6	8.95	3.10
	TMLX080C16MP11	FC/MC62D	1	1040	33.8	—	—	3.42
			2	1550	48.0	32.2	9.70	3.78
			2*	1040	46.0	29.0	9.05	3.22
	TMLX080C16MP11	FC/PC60C	1	1020	34.0	—	—	3.32
			2	1525	48.0	32.4	9.60	3.62
			2*	1020	46.0	29.6	8.95	3.08
	TMLX080C16MP11	FC64D	1	1045	34.6	—	—	3.58
			2	1550	48.5	32.6	9.85	3.96
			2*	1045	46.5	29.8	9.20	3.36
	TMLX080C16MP11	UC48C	1	1030	34.6	—	—	3.48
			2	1525	48.5	32.6	9.70	3.78
			2*	1030	46.5	29.8	9.15	3.28
	TMLX080C16MP11	UC48D	1	1045	34.6	—	—	3.48
			2	1550	48.0	32.6	9.70	3.78
			2*	1045	46.5	29.8	9.15	3.28
	TMLX080C16MP11	UC60C	1	1020	33.6	—	—	3.24
			2	1525	48.0	32.0	9.55	3.62
			2*	1020	46.0	29.0	8.90	3.06
	TMLX080C16MP11	UC60D	1	1045	33.6	—	—	3.24
			2	1550	48.0	32.0	9.60	3.62
			2*	1045	46.0	29.0	8.95	3.06
	TMLX100C16MP11	FC/MC/PC48C	1	1030	33.8	—	—	3.36
			2	1525	48.0	32.8	9.65	3.70
			2*	1030	46.0	29.6	9.00	3.14
	TMLX100C16MP11	FC/MC/PC48D	1	1045	33.8	—	—	3.36
			2	1550	48.0	32.8	9.70	3.78
			2*	1045	46.0	29.6	9.00	3.14
	TMLX100C16MP11	FC/MC/PC60D	1	1045	34.2	—	—	3.34
			2	1550	48.0	32.6	9.65	3.72
			2*	1045	46.0	29.6	8.95	3.10
	TMLX100C16MP11	FC/MC62D	1	1040	33.8	—	—	3.42
			2	1550	48.0	32.2	9.70	3.78
			2*	1040	46.0	29.0	9.05	3.22
	TMLX100C16MP11	FC/PC60C	1	1020	34.0	—	—	3.32
			2	1525	48.0	32.4	9.60	3.62
			2*	1020	46.0	29.6	8.95	3.08
TMLX100C16MP11	FC64D	1	1045	34.6	—	—	3.58	
		2	1550	48.5	32.6	9.85	3.96	
		2*	1045	46.5	29.8	9.20	3.36	

For notes, see Page 44.

HEATING CAPACITY - With High Efficiency Motor Furnaces (Continued)

UNIT MODEL	FURNACE MODEL	COIL ¹ MODEL	HEATING ²					
			STAGE	RATED CFM	NET MBH		HSPF	COP @ 47°F
					47°F OD	17°F OD		
18 SEER HP WITH HIGH EFFICIENCY MOTOR FURNACES³								
HL8B048F4(C)	TMLX100C16MP11	UC48C	1	1030	34.6	—	—	3.48
			2	1525	48.5	32.6	9.70	3.78
			2*	1030	46.5	29.8	9.15	3.28
	TMLX100C16MP11	UC48D	1	1045	34.6	—	—	3.48
			2	1550	48.0	32.6	9.70	3.78
			2*	1045	46.5	29.8	9.15	3.28
	TMLX100C16MP11	UC60C	1	1020	33.6	—	—	3.24
			2	1525	48.0	32.0	9.55	3.62
			2*	1020	46.0	29.0	8.90	3.06
	TMLX100C16MP11	UC60D	1	1045	33.6	—	—	3.24
			2	1550	48.0	32.0	9.60	3.62
			2*	1045	46.0	29.0	8.95	3.06
	TMLX100C20MP11	FC/MC/PC48C	1	1090	34.2	—	—	3.42
			2	1550	48.0	32.6	9.70	3.74
			2*	1090	46.0	29.8	9.25	3.20
	TMLX100C20MP11	FC/MC/PC48D	1	1105	34.2	—	—	3.44
			2	1575	48.0	32.6	9.75	3.76
			2*	1105	46.0	29.8	9.30	3.22
	TMLX100C20MP11	FC/MC/PC60D	1	1105	34.2	—	—	3.40
			2	1575	48.0	32.2	9.70	3.72
			2*	1105	46.0	29.6	9.25	3.18
	TMLX100C20MP11	FC/MC62D	1	1100	34.0	—	—	3.48
			2	1575	48.0	32.2	9.80	3.82
			2*	1100	46.0	29.2	9.35	3.28
	TMLX100C20MP11	FC/PC60C	1	1085	34.2	—	—	3.32
			2	1550	48.0	32.4	9.70	3.74
			2*	1085	46.0	29.6	9.25	3.08
	TMLX100C20MP11	UC48C	1	1090	34.8	—	—	3.54
			2	1550	48.0	32.6	9.80	3.84
			2*	1090	47.0	30.0	9.50	3.34
	TMLX100C20MP11	UC48D	1	1105	34.8	—	—	3.56
			2	1575	48.0	32.6	9.80	3.86
			2*	1105	47.0	29.8	9.25	3.36
	TMLX100C20MP11	UC60C	1	1085	33.6	—	—	3.32
			2	1550	47.5	31.8	9.65	3.68
			2*	1085	46.0	29.0	9.30	3.14
	TMLX100C20MP11	UC60D	1	1105	33.8	—	—	3.34
			2	1575	48.0	31.8	9.70	3.70
			2*	1105	46.0	29.2	9.30	3.16
	TMLX120C20MP11	FC/MC/PC48C	1	1090	34.2	—	—	3.42
			2	1550	48.0	32.6	9.70	3.74
			2*	1090	46.0	29.8	9.25	3.20
	TMLX120C20MP11	FC/MC/PC48D	1	1105	34.2	—	—	3.44
			2	1575	48.0	32.6	9.75	3.76
			2*	1105	46.0	29.8	9.30	3.22
	TMLX120C20MP11	FC/MC/PC60D	1	1105	34.2	—	—	3.40
			2	1575	48.0	32.2	9.70	3.72
			2*	1105	46.0	29.6	9.25	3.18
	TMLX120C20MP11	FC/MC62D	1	1100	34.0	—	—	3.48
			2	1575	48.0	32.2	9.80	3.82
			2*	1100	46.0	29.2	9.35	3.28

For notes, see Page 44.

HEATING CAPACITY - With High Efficiency Motor Furnaces (Continued)

UNIT MODEL	FURNACE MODEL	COIL ¹ MODEL	HEATING ²					
			STAGE	RATED CFM	NET MBH		HSPF	COP @ 47°F
					47°F OD	17°F OD		
18 SEER HP WITH HIGH EFFICIENCY MOTOR FURNACES³								
HL8B048F4(C)	TMLX120C20MP11	FC/PC60C	1	1085	34.2	—	—	3.32
			2	1550	48.0	32.4	9.70	3.74
			2*	1085	46.0	29.6	9.25	3.08
	TMLX120C20MP11	UC48C	1	1090	34.8	—	—	3.54
			2	1550	48.0	32.6	9.80	3.84
			2*	1090	47.0	30.0	9.50	3.34
	TMLX120C20MP11	UC48D	1	1105	34.8	—	—	3.56
			2	1575	48.0	32.6	9.80	3.86
			2*	1105	47.0	29.8	9.25	3.36
	TMLX120C20MP11	UC60C	1	1085	33.6	—	—	3.32
			2	1550	47.5	31.8	9.65	3.68
			2*	1085	46.0	29.0	9.30	3.14
	TMLX120C20MP11	UC60D	1	1105	33.8	—	—	3.34
			2	1575	48.0	31.8	9.70	3.70
			2*	1105	46.0	29.2	9.30	3.16
	TM9E100C20MP11	FC/MC/PC48C	1	945	33.8	—	—	3.24
			2	1500	48.0	32.6	9.55	3.64
			2*	945	45.5	29.4	8.85	3.02
	TM9E100C20MP11	FC/MC/PC48D	1	960	33.8	—	—	3.26
			2	1525	48.0	32.8	9.65	3.70
			2*	960	45.5	29.4	8.85	3.04
	TM9E100C20MP11	FC/MC/PC60D	1	960	34.0	—	—	3.22
			2	1525	48.0	32.4	9.60	3.64
			2*	960	45.5	29.4	8.85	3.00
	TM9E100C20MP11	FC/MC62D	1	985	33.8	—	—	3.36
			2	1550	48.0	32.2	9.70	3.78
			2*	985	46.0	29.0	9.00	3.16
	TM9E100C20MP11	FC64D	1	980	34.4	—	—	3.48
			2	1550	48.5	32.6	9.80	3.90
			2*	980	46.5	29.6	9.05	3.22
	TM9E100C20MP11	UC48C	1	945	34.4	—	—	3.40
			2	1500	48.5	32.8	9.65	3.74
			2*	945	46.5	29.8	8.95	3.16
	TM9E100C20MP11	UC48D	1	960	34.6	—	—	3.44
			2	1525	48.5	32.6	9.70	3.78
			2*	960	46.5	29.8	9.00	3.16
	TM9E100C20MP11	UC60D	1	960	33.4	—	—	3.16
			2	1525	48.0	32.0	9.55	3.62
			2*	960	45.5	28.8	8.80	2.98
	TM9E120D20MP11	FC/MC/PC48D	1	965	33.8	—	—	3.28
			2	1525	48.0	32.6	9.65	3.70
			2*	965	45.5	29.4	8.90	3.04
TM9E120D20MP11	FC/MC/PC60D	1	980	34.0	—	—	3.26	
		2	1550	48.0	32.2	9.65	3.68	
		2*	980	45.5	29.2	8.90	3.04	
TM9E120D20MP11	FC/MC62D	1	980	33.8	—	—	3.36	
		2	1550	48.0	32.2	9.75	3.80	
		2*	980	46.0	28.8	9.00	3.14	
TM9E120D20MP11	FC64D	1	960	34.2	—	—	3.46	
		2	1525	48.5	32.4	9.80	3.88	
		2*	960	46.0	29.6	9.00	3.18	

For notes, see Page 44.

HEATING CAPACITY - With High Efficiency Motor Furnaces (Continued)

UNIT MODEL	FURNACE MODEL	COIL ¹ MODEL	HEATING ²					
			STAGE	RATED CFM	NET MBH		HSPF	COP @ 47°F
					47°F OD	17°F OD		
18 SEER HP WITH HIGH EFFICIENCY MOTOR FURNACES³								
HL8B048F4(C)	TM9E120D20MP11	UC48D	1	965	34.4	—	—	3.44
			2	1525	48.0	32.6	9.75	3.80
			2*	965	46.5	29.8	9.00	3.18
	TM9E120D20MP11	UC60D	1	980	33.4	—	—	3.26
			2	1550	47.5	31.8	9.65	3.64
			2*	980	46.0	29.0	8.95	3.08
	TM9X100C20MP11	FC/MC/PC48C	1	945	33.8	—	—	3.24
			2	1500	48.0	32.6	9.55	3.64
			2*	945	45.5	29.4	8.85	3.02
	TM9X100C20MP11	FC/MC/PC48D	1	960	33.8	—	—	3.26
			2	1525	48.0	32.8	9.65	3.70
			2*	960	45.5	29.4	8.85	3.04
	TM9X100C20MP11	FC/MC/PC60D	1	960	34.0	—	—	3.22
			2	1525	48.0	32.4	9.60	3.64
			2*	960	45.5	29.4	8.85	3.00
	TM9X100C20MP11	FC/MC62D	1	985	33.8	—	—	3.36
			2	1550	48.0	32.2	9.70	3.78
			2*	985	46.0	29.0	9.00	3.16
	TM9X100C20MP11	FC64D	1	980	34.4	—	—	3.48
			2	1550	48.5	32.6	9.80	3.90
			2*	980	46.5	29.6	9.05	3.22
	TM9X100C20MP11	UC48C	1	945	34.4	—	—	3.40
			2	1500	48.5	32.8	9.65	3.74
			2*	945	46.5	29.8	8.95	3.16
	TM9X100C20MP11	UC48D	1	960	34.6	—	—	3.44
			2	1525	48.5	32.6	9.70	3.78
			2*	960	46.5	29.8	9.00	3.16
	TM9X100C20MP11	UC60D	1	960	33.4	—	—	3.16
			2	1525	48.0	32.0	9.55	3.62
			2*	960	45.5	28.8	8.80	2.98
	TM9X120D20MP11	FC/MC/PC48D	1	965	33.8	—	—	3.28
			2	1525	48.0	32.6	9.65	3.70
			2*	965	45.5	29.4	8.90	3.04
	TM9X120D20MP11	FC/MC/PC60D	1	980	34.0	—	—	3.26
			2	1550	48.0	32.2	9.65	3.68
			2*	980	45.5	29.2	8.90	3.04
	TM9X120D20MP11	FC/MC62D	1	980	33.8	—	—	3.36
			2	1550	48.0	32.2	9.75	3.80
			2*	980	46.0	28.8	9.00	3.14
	TM9X120D20MP11	FC64D	1	960	34.2	—	—	3.46
			2	1525	48.5	32.4	9.80	3.88
			2*	960	46.0	29.6	9.00	3.18
	TM9X120D20MP11	UC48D	1	965	34.4	—	—	3.44
			2	1525	48.0	32.6	9.75	3.80
			2*	965	46.5	29.8	9.00	3.18
	TM9X120D20MP11	UC60D	1	980	33.4	—	—	3.26
			2	1550	47.5	31.8	9.65	3.64
			2*	980	46.0	29.0	8.95	3.08

For notes, see Page 44.

HEATING CAPACITY - With High Efficiency Motor Furnaces (Continued)

UNIT MODEL	FURNACE MODEL	COIL ¹ MODEL	HEATING ²					
			STAGE	RATED CFM	NET MBH		HSPF	COP @ 47°F
					47°F OD	17°F OD		
18 SEER HP WITH HIGH EFFICIENCY MOTOR FURNACES³								
HL8B060F4(C)	T*(8,L)V*C16	FC/PC60C	1	1025	41.0	—	—	2.92
			2	1600	57.5	38.5	9.15	3.48
			2*	1025	58.0	37.6	8.75	2.68
	T*(8,L)V*C20	FC/MC/PC60D	1	1060	41.0	—	—	3.00
			2	1600	57.0	38.5	9.25	3.52
			2*	1060	58.0	37.6	8.85	2.74
	T*(8,L)V*C20	FC/MC62D	1	1015	40.5	—	—	3.00
			2	1600	57.5	38.0	9.20	3.58
			2*	1015	58.5	37.2	8.85	2.78
	T*(8,L)V*C20	FC/PC60C	1	1060	41.0	—	—	3.00
			2	1600	57.0	38.5	9.25	3.52
			2*	1060	58.0	37.6	8.85	2.74
	T*(8,L)V*C20	FC64D	1	1060	41.5	—	—	3.16
			2	1855	59.0	38.5	9.30	3.82
			2*	1060	59.0	38.1	9.05	2.94
	T*(8,L)V*C20	UC60C	1	1015	40.0	—	—	2.88
			2	1605	57.0	38.0	9.25	3.52
			2*	1015	58.0	37.2	8.95	2.68
	T*9V*C20	FC/MC/PC60D	1	1055	41.0	—	—	2.96
			2	1655	57.5	38.5	9.15	3.50
			2*	1055	58.0	37.6	8.75	2.72
	T*9V*C20	FC/MC62D	1	1040	41.0	—	—	3.04
			2	1655	58.0	38.5	9.20	3.62
			2*	1040	58.5	37.2	8.85	2.82
	T*9V*C20	FC/PC60C	1	1055	41.0	—	—	2.96
			2	1655	57.5	38.5	9.15	3.50
			2*	1055	58.0	37.6	8.75	2.72
	T*9V*C20	FC64D	1	1040	41.5	—	—	3.12
			2	1655	58.0	38.5	9.25	3.72
			2*	1040	59.0	37.6	8.95	2.88
	T*9V*C20	UC60C	1	1055	40.5	—	—	2.92
			2	1655	57.5	38.5	9.15	3.50
			2*	1055	58.5	37.4	8.80	2.72
	T*9V*D20	FC/MC/PC60D	1	1070	41.0	—	—	2.98
			2	1615	57.0	38.5	9.15	3.50
			2*	1070	58.5	37.6	8.75	2.74
	T*9V*D20	FC/MC62D	1	1085	41.0	—	—	3.08
			2	1630	57.5	38.0	9.25	3.62
			2*	1085	59.0	37.2	8.85	2.88
	T*9V*D20	FC64D	1	1085	41.5	—	—	3.18
			2	1630	58.0	38.5	9.30	3.72
			2*	1085	59.0	37.6	8.90	2.94
T*9V*D20	UC60D	1	1070	40.5	—	—	2.92	
		2	1615	57.0	38.0	9.15	3.48	
		2*	1070	58.5	37.4	8.75	2.74	
TM8X080C16MP11	FC/MC/PC60D	1	1045	40.5	—	—	2.98	
		2	1550	57.0	38.5	9.15	3.44	
		2*	1045	58.0	37.4	9.00	2.74	
TM8X080C16MP11	FC/MC62D	1	1040	40.5	—	—	3.06	
		2	1550	57.5	38.0	9.20	3.56	
		2*	1040	58.5	37.0	9.10	2.84	

For notes, see Page 44.

HEATING CAPACITY - With High Efficiency Motor Furnaces (Continued)

UNIT MODEL	FURNACE MODEL	COIL ¹ MODEL	HEATING ²					
			STAGE	RATED CFM	NET MBH		HSPF	COP @ 47°F
					47°F OD	17°F OD		
18 SEER HP WITH HIGH EFFICIENCY MOTOR FURNACES³								
HL8B060F4(C)	TM8X080C16MP11	FC/PC60C	1	1020	40.5	—	—	2.94
			2	1525	57.0	38.5	9.10	3.42
			2*	1020	58.0	37.4	8.95	2.70
	TM8X080C16MP11	FC64D	1	1045	41.0	—	—	3.18
			2	1550	57.5	38.5	9.30	3.66
			2*	1045	58.0	37.2	9.05	2.92
	TM8X080C16MP11	UC60C	1	1020	40.5	—	—	2.90
			2	1525	57.0	38.0	9.10	3.40
			2*	1020	58.0	37.0	8.95	2.68
	TM8X080C16MP11	UC60D	1	1045	40.0	—	—	2.90
			2	1550	57.0	38.0	9.15	3.42
			2*	1045	58.0	37.0	9.00	2.68
	TM8X100C16MP11	FC/MC/PC60D	1	1045	40.5	—	—	2.98
			2	1550	57.0	38.5	9.15	3.44
			2*	1045	58.0	37.4	9.00	2.74
	TM8X100C16MP11	FC/MC62D	1	1040	40.5	—	—	3.06
			2	1550	57.5	38.0	9.20	3.56
			2*	1040	58.5	37.0	9.10	2.84
	TM8X100C16MP11	FC/PC60C	1	1020	40.5	—	—	2.94
			2	1525	57.0	38.5	9.10	3.42
			2*	1020	58.0	37.4	8.95	2.70
	TM8X100C16MP11	FC64D	1	1045	41.0	—	—	3.18
			2	1550	57.5	38.5	9.30	3.66
			2*	1045	58.0	37.2	9.05	2.92
	TM8X100C16MP11	UC60C	1	1020	40.5	—	—	2.90
			2	1525	57.0	38.0	9.10	3.40
			2*	1020	58.0	37.0	8.95	2.68
	TM8X100C16MP11	UC60D	1	1045	40.0	—	—	2.90
			2	1550	57.0	38.0	9.15	3.42
			2*	1045	58.0	37.0	9.00	2.68
	TM8X100C20MP11	FC/MC/PC60D	1	1105	41.0	—	—	3.04
			2	1575	57.0	38.5	9.20	3.48
			2*	1105	58.0	37.6	8.95	2.80
	TM8X100C20MP11	FC/MC62D	1	1100	40.5	—	—	3.12
			2	1575	57.5	38.0	9.30	3.60
			2*	1100	58.5	36.8	8.95	2.92
	TM8X100C20MP11	FC/PC60C	1	1085	41.0	—	—	3.02
			2	1550	57.0	38.5	9.20	3.46
			2*	1085	58.0	37.6	8.90	2.76
	TM8X100C20MP11	UC60C	1	1085	40.5	—	—	2.98
			2	1550	57.0	38.0	9.20	3.46
			2*	1085	58.5	37.0	8.90	2.76
	TM8X100C20MP11	UC60D	1	1105	40.5	—	—	3.00
			2	1575	57.0	38.0	9.20	3.48
			2*	1105	58.5	37.2	8.95	2.78
	TM8X120C20MP11	FC/MC/PC60D	1	1105	41.0	—	—	3.04
			2	1575	57.0	38.5	9.20	3.48
			2*	1105	58.0	37.6	8.95	2.80
	TM8X120C20MP11	FC/MC62D	1	1100	40.5	—	—	3.12
			2	1575	57.5	38.0	9.30	3.60
			2*	1100	58.5	36.8	8.95	2.92

For notes, see Page 44.

HEATING CAPACITY - With High Efficiency Motor Furnaces (Continued)

UNIT MODEL	FURNACE MODEL	COIL ¹ MODEL	HEATING ²					
			STAGE	RATED CFM	NET MBH		HSPF	COP @ 47°F
					47°F OD	17°F OD		
18 SEER HP WITH HIGH EFFICIENCY MOTOR FURNACES³								
HL8B060F4(C)	TM8X120C20MP11	FC/PC60C	1	1085	41.0	—	—	3.02
			2	1550	57.0	38.5	9.20	3.46
			2*	1085	58.0	37.6	8.90	2.76
	TM8X120C20MP11	UC60C	1	1085	40.5	—	—	2.98
			2	1550	57.0	38.0	9.20	3.46
			2*	1085	58.5	37.0	8.90	2.76
	TM8X120C20MP11	UC60D	1	1105	40.5	—	—	3.00
			2	1575	57.0	38.0	9.20	3.48
			2*	1105	58.5	37.2	8.95	2.78
	TMLX080C16MP11	FC/MC/PC60D	1	1045	40.5	—	—	2.98
			2	1550	57.0	38.5	9.15	3.44
			2*	1045	58.0	37.4	9.00	2.74
	TMLX080C16MP11	FC/MC62D	1	1040	40.5	—	—	3.06
			2	1550	57.5	38.0	9.20	3.56
			2*	1040	58.5	37.0	9.10	2.84
	TMLX080C16MP11	FC/PC60C	1	1020	40.5	—	—	2.94
			2	1525	57.0	38.5	9.10	3.42
			2*	1020	58.0	37.4	8.95	2.70
	TMLX080C16MP11	FC64D	1	1045	41.0	—	—	3.18
			2	1550	57.5	38.5	9.30	3.66
			2*	1045	58.0	37.2	9.05	2.92
	TMLX080C16MP11	UC60C	1	1020	40.5	—	—	2.90
			2	1525	57.0	38.0	9.10	3.40
			2*	1020	58.0	37.0	8.95	2.68
	TMLX080C16MP11	UC60D	1	1045	40.0	—	—	2.90
			2	1550	57.0	38.0	9.15	3.42
			2*	1045	58.0	37.0	9.00	2.68
	TMLX100C16MP11	FC/MC/PC60D	1	1045	40.5	—	—	2.98
			2	1550	57.0	38.5	9.15	3.44
			2*	1045	58.0	37.4	9.00	2.74
	TMLX100C16MP11	FC/MC62D	1	1040	40.5	—	—	3.06
			2	1550	57.5	38.0	9.20	3.56
			2*	1040	58.5	37.0	9.10	2.84
	TMLX100C16MP11	FC/PC60C	1	1020	40.5	—	—	2.94
			2	1525	57.0	38.5	9.10	3.42
			2*	1020	58.0	37.4	8.95	2.70
	TMLX100C16MP11	FC64D	1	1045	41.0	—	—	3.18
			2	1550	57.5	38.5	9.30	3.66
			2*	1045	58.0	37.2	9.05	2.92
	TMLX100C16MP11	UC60C	1	1020	40.5	—	—	2.90
			2	1525	57.0	38.0	9.10	3.40
			2*	1020	58.0	37.0	8.95	2.68
	TMLX100C16MP11	UC60D	1	1045	40.0	—	—	2.90
			2	1550	57.0	38.0	9.15	3.42
			2*	1045	58.0	37.0	9.00	2.68
	TMLX100C20MP11	FC/MC/PC60D	1	1105	41.0	—	—	3.04
			2	1575	57.0	38.5	9.20	3.48
			2*	1105	58.0	37.6	8.95	2.80
TMLX100C20MP11	FC/MC62D	1	1100	40.5	—	—	3.12	
		2	1575	57.5	38.0	9.30	3.60	
		2*	1100	58.5	36.8	8.95	2.92	

For notes, see Page 44.

HEATING CAPACITY - With High Efficiency Motor Furnaces (Continued)

UNIT MODEL	FURNACE MODEL	COIL ¹ MODEL	HEATING ²					
			STAGE	RATED CFM	NET MBH		HSPF	COP @ 47°F
					47°F OD	17°F OD		
18 SEER HP WITH HIGH EFFICIENCY MOTOR FURNACES³								
HL8B060F4(C)	TMLX100C20MP11	FC/PC60C	1	1085	41.0	—	—	3.02
			2	1550	57.0	38.5	9.20	3.46
			2*	1085	58.0	37.6	8.90	2.76
	TMLX100C20MP11	UC60C	1	1085	40.5	—	—	2.98
			2	1550	57.0	38.0	9.20	3.46
			2*	1085	58.5	37.0	8.90	2.76
	TMLX100C20MP11	UC60D	1	1105	40.5	—	—	3.00
			2	1575	57.0	38.0	9.20	3.48
			2*	1105	58.5	37.2	8.95	2.78
	TMLX120C20MP11	FC/MC/PC60D	1	1105	41.0	—	—	3.04
			2	1575	57.0	38.5	9.20	3.48
			2*	1105	58.0	37.6	8.95	2.80
	TMLX120C20MP11	FC/MC62D	1	1100	40.5	—	—	3.12
			2	1575	57.5	38.0	9.30	3.60
			2*	1100	58.5	36.8	8.95	2.92
	TMLX120C20MP11	FC/PC60C	1	1085	41.0	—	—	3.02
			2	1550	57.0	38.5	9.20	3.46
			2*	1085	58.0	37.6	8.90	2.76
	TMLX120C20MP11	UC60C	1	1085	40.5	—	—	2.98
			2	1550	57.0	38.0	9.20	3.46
			2*	1085	58.5	37.0	8.90	2.76
	TMLX120C20MP11	UC60D	1	1105	40.5	—	—	3.00
			2	1575	57.0	38.0	9.20	3.48
			2*	1105	58.5	37.2	8.95	2.78
	TM9E100C20MP11	FC/MC/PC60D	1	960	40.5	—	—	2.88
			2	1525	57.0	38.5	9.10	3.42
			2*	960	57.5	37.6	9.00	2.62
	TM9E100C20MP11	FC/MC62D	1	985	40.5	—	—	3.00
			2	1550	57.5	38.0	9.25	3.56
			2*	985	58.0	36.8	9.15	2.76
	TM9E100C20MP11	FC64D	1	980	41.0	—	—	3.10
			2	1550	57.5	38.5	9.30	3.66
			2*	980	58.5	37.4	9.25	2.82
	TM9E100C20MP11	UC60D	1	960	40.0	—	—	2.82
			2	1525	57.0	38.0	9.10	3.42
			2*	960	57.5	37.2	9.00	2.62
	TM9E120D20MP11	FC/MC/PC60D	1	980	40.5	—	—	2.90
			2	1550	57.0	38.5	9.20	3.46
			2*	980	57.5	37.6	9.05	2.66
	TM9E120D20MP11	FC/MC62D	1	980	40.5	—	—	3.00
			2	1550	57.5	38.0	9.25	3.58
			2*	980	58.0	36.8	9.15	2.76
	TM9E120D20MP11	FC64D	1	960	41.0	—	—	3.06
			2	1525	57.5	38.0	9.30	3.66
			2*	960	58.5	37.4	9.25	2.78
	TM9E120D20MP11	UC60D	1	980	40.0	—	—	2.90
			2	1550	57.0	38.0	9.15	3.42
			2*	980	58.0	36.8	9.10	2.70
TM9X100C20MP11	FC/MC/PC60D	1	960	40.5	—	—	2.88	
		2	1525	57.0	38.5	9.10	3.42	
		2*	960	57.5	37.6	9.00	2.62	

For notes, see Page 44.

HEATING CAPACITY - With High Efficiency Motor Furnaces (Continued)

UNIT MODEL	FURNACE MODEL	COIL ¹ MODEL	HEATING ²					
			STAGE	RATED CFM	NET MBH		HSPF	COP @ 47°F
					47°F OD	17°F OD		
18 SEER HP WITH HIGH EFFICIENCY MOTOR FURNACES³								
HL8B060F4(C)	TM9X100C20MP11	FC/MC62D	1	985	40.5	—	—	3.00
			2	1550	57.5	38.0	9.25	3.56
			2*	985	58.0	36.8	9.15	2.76
	TM9X100C20MP11	FC64D	1	980	41.0	—	—	3.10
			2	1550	57.5	38.5	9.30	3.66
			2*	980	58.5	37.4	9.25	2.82
	TM9X100C20MP11	UC60D	1	960	40.0	—	—	2.82
			2	1525	57.0	38.0	9.10	3.42
			2*	960	57.5	37.2	9.00	2.62
	TM9X120D20MP11	FC/MC/PC60D	1	980	40.5	—	—	2.90
			2	1550	57.0	38.5	9.20	3.46
			2*	980	57.5	37.6	9.05	2.66
	TM9X120D20MP11	FC/MC62D	1	980	40.5	—	—	3.00
			2	1550	57.5	38.0	9.25	3.58
			2*	980	58.0	36.8	9.15	2.76
	TM9X120D20MP11	FC64D	1	960	41.0	—	—	3.06
			2	1525	57.5	38.0	9.30	3.66
			2*	960	58.5	37.4	9.25	2.78
	TM9X120D20MP11	UC60D	1	980	40.0	—	—	2.90
			2	1550	57.0	38.0	9.15	3.42
			2*	980	58.0	36.8	9.10	2.70

- MC coils available with a factory installed horizontal drain pan. See price pages for specific model number.
- Heating MBH based on AHRI standards of 70°F DB (Dry Bulb) entering indoor air, 72% RH (Relative Humidity) outdoor air with 25 feet of interconnecting piping and no supplemental electric heat operation.
- High Efficiency Motor Furnaces have B.O.D (Blower on Delay) standard.
* Notates "Hot Heat Pump" performance. These ratings are not AHRI listed.
COP equals MBH output divided by (total KW input x 3.412).
HSPF (Heating Seasonal Performance Factor) is the total heating output during a normal annual usage period for heating divided by the total electric power input during the same period.
— = Not Applicable.
PSC furnaces, such as the TG8S, TGLS, and TG9S, use Coil Only Ratings.

ACCESSORIES & APPLICATIONS

Refer to Price Manual for specific model numbers.

Application Limits		
Maximum Lineset Equivalent Length	75 Ft	
Outdoor Ambient Temperature Limits		
Cooling Operation	Maximum DB	115°F
	Minimum DB	50°F
Heating Operation	Maximum DB	75°F
	Minimum DB	-10°F

Long Lineset Applications - For installations with more than 75' of equivalent lineset length, refer to the current version of the **Piping Application Guide 247077-UAD-H-0209**, available in the Application Bulletins section on UPGnet.

Start Assist Kit (S1-2SA067*) - Provides increased starting torque for areas with low voltage. See Hard Start Kit Accessory Installation Manual for Hard Start Kit part number for each model.

TXV Kits - S1-1TVM series thermal expansion valves precisely meter refrigerant for optimum performance over a wide range of conditions. See System Charge table for TXV part number for each model.

Bonnet Sensor (S1-2SB13700124) - The bonnet sensor is used to sense plenum temperature, and is optional with a gas or oil back-up heat source. Compatible only with 13 SEER and higher heat pumps.

Dehumidistat (S1-2HU16700124) - Provides increased dehumidification when matched with variable speed furnace or air handler.

Heat Pump Risers - (S1-52635389000, S1-52635390000, S1-52635391000) - 3", 6", or 12" risers mount easily in composite base pan recesses, ensuring the unit stays clear of snow and ice build-up in harsh winter weather.

Thermostats - Compatible thermostat controls are available through accessory sourcing. For optimum performance, these outdoor units are fully compatible with the Residential Touchscreen Communicating Control (Zoning and Non-Zoning versions). For more information, see the Residential Control Systems section of the Product Equipment Catalog.

SOUND POWER RATINGS

Stage 1 - Cooling		Octave Band Sound Power Level (db re. 1-pW)								
Model Number	63	125	250	500	1000	2000	4000	8000	dBA	SQI
HL8B024F4(C)	69	75	70	69	63	56	50	45	69	19
HL8B036F4(C)	68	76	69	70	64	57	51	46	70	19
HL8B048F4(C)	68	76	70	69	64	58	53	48	70	19
HL8B060F4(C)	70	82	69	72	66	60	54	49	72	19

Stage 2 - Cooling		Octave Band Sound Power Level (db re. 1-pW)								
Model Number	63	125	250	500	1000	2000	4000	8000	dBA	SQI
HL8B024F4(C)	68	73	70	68	62	56	50	47	68	19
HL8B036F4(C)	68	75	71	71	65	58	52	50	71	19
HL8B048F4(C)	67	77	69	69	64	58	53	49	70	19
HL8B060F4(C)	69	85	69	70	66	60	54	50	73	19

Stage 1 - Heating		Octave Band Sound Power Level (db re. 1-pW)								
Model Number	63	125	250	500	1000	2000	4000	8000	dBA	SQI
HL8B024F4(C)	68	72	68	69	61	56	51	47	68	19
HL8B036F4(C)	70	75	70	69	65	58	53	50	70	19
HL8B048F4(C)	69	73	71	68	64	58	53	51	69	19
HL8B060F4(C)	72	76	70	75	66	59	55	52	73	19

Stage 2 - Heating		Octave Band Sound Power Level (db re. 1-pW)								
Model Number	63	125	250	500	1000	2000	4000	8000	dBA	SQI
HL8B024F4(C)	68	72	69	68	61	56	51	48	68	19
HL8B036F4(C)	68	76	71	69	65	58	53	51	71	19
HL8B048F4(C)	69	75	73	69	65	59	54	51	70	19
HL8B060F4(C)	71	79	69	74	66	60	56	53	73	19

Rated in accordance with ARI Standard 270-1995.

TYPICAL INSTALLATION

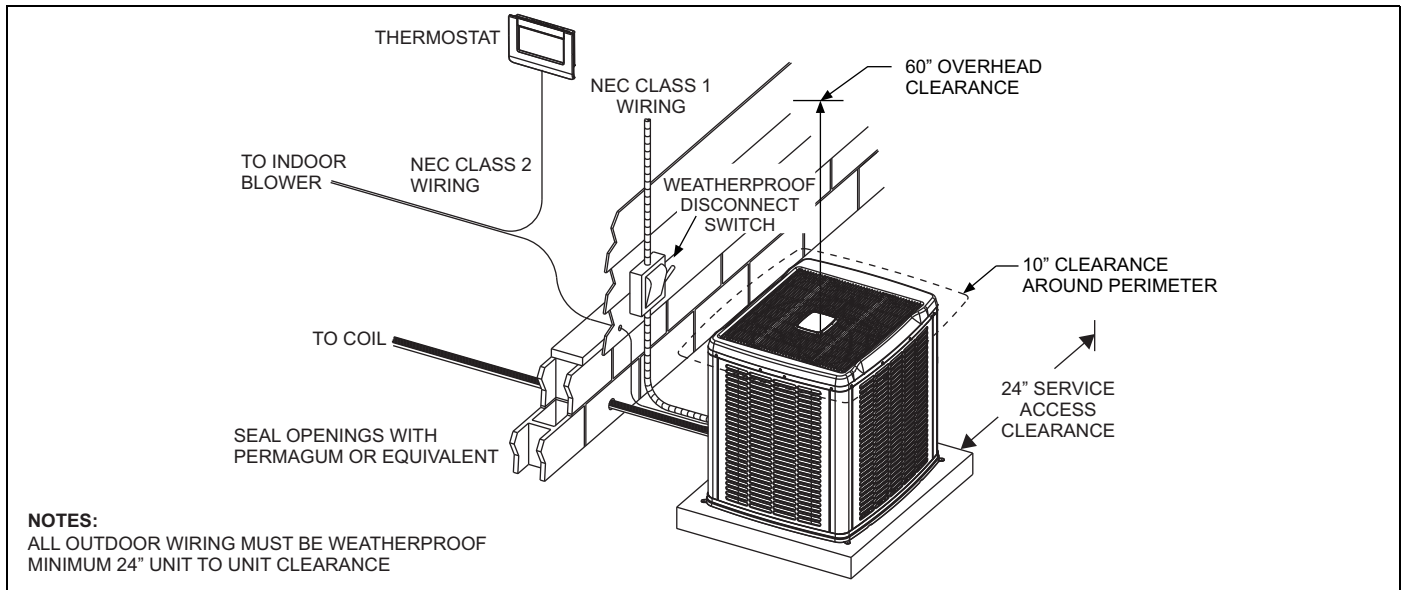

COOLING PERFORMANCE DATA - LOW CFM 1-STAGE OPERATION																
OUTDOOR UNIT MODEL NO.		HL8B024F4C														
INDOOR COIL MODEL NO.		FC/MC48D + MV12D														
AIR TEMP. ENTERING OUTDOOR UNIT (°F)	ID CFM	550					600					650				
	ID DB (°F)	80	80	75	80	80	80	80	75	80	80	80	80	75	80	80
	ID WB (°F)	57	62	62	67	72	57	62	62	67	72	57	62	62	67	72
65	T.C.	17.7	18.5	19.0	20.5	22.9	18.3	19.0	19.4	21.1	23.4	19.0	19.5	19.8	21.6	23.8
	S.C.	17.0	16.2	14.3	14.1	11.6	17.7	17.1	14.9	14.8	11.9	18.5	18.0	15.4	15.5	12.3
	K.W.	0.81	0.80	0.80	0.79	0.76	0.80	0.79	0.79	0.77	0.75	0.79	0.77	0.79	0.76	0.74
75	T.C.	17.0	17.7	18.0	19.7	21.8	17.6	18.2	18.4	20.2	22.2	18.2	18.7	18.8	20.6	22.6
	S.C.	16.3	15.8	13.9	13.6	11.0	17.0	16.6	14.5	14.3	11.5	17.7	17.5	15.1	15.0	11.9
	K.W.	0.97	0.97	0.97	0.95	0.92	0.96	0.95	0.96	0.94	0.91	0.95	0.94	0.95	0.93	0.90
85	T.C.	16.3	16.8	16.9	18.8	20.8	16.8	17.4	17.4	19.2	21.1	17.4	17.9	17.8	19.6	21.4
	S.C.	15.7	15.3	13.4	13.1	10.5	16.3	16.1	14.1	13.8	11.0	17.0	16.9	14.8	14.5	11.5
	K.W.	1.13	1.14	1.14	1.11	1.09	1.12	1.12	1.13	1.10	1.07	1.11	1.11	1.12	1.09	1.06
95	T.C.	15.6	16.0	15.9	18.0	19.7	16.1	16.5	16.4	18.3	20.0	16.5	17.1	16.8	18.6	20.2
	S.C.	15.0	14.8	12.9	12.6	10.0	15.6	15.6	13.7	13.4	10.5	16.2	16.3	14.4	14.1	11.1
	K.W.	1.29	1.30	1.30	1.27	1.25	1.28	1.29	1.29	1.26	1.24	1.27	1.27	1.29	1.26	1.22
105	T.C.	14.6	15.1	14.8	16.6	18.3	15.1	15.6	15.2	17.0	18.6	15.6	16.1	15.7	17.4	18.9
	S.C.	14.1	14.1	12.3	12.1	9.6	14.7	14.7	13.1	12.8	10.1	15.3	15.2	13.8	13.6	10.6
	K.W.	1.53	1.53	1.54	1.51	1.49	1.52	1.52	1.53	1.50	1.48	1.51	1.51	1.52	1.50	1.47
115	T.C.	13.7	14.2	13.7	15.3	16.9	14.2	14.7	14.1	15.8	17.3	14.6	15.1	14.5	16.2	17.6
	S.C.	13.3	13.5	11.8	11.6	9.2	13.9	13.8	12.5	12.3	9.7	14.5	14.1	13.1	13.1	10.2
	K.W.	1.76	1.76	1.77	1.74	1.72	1.75	1.74	1.75	1.74	1.71	1.74	1.74	1.75	1.73	1.70
125	T.C.	12.8	13.4	12.6	14.1	15.6	13.3	13.8	13.0	14.5	15.9	13.7	14.2	13.4	14.9	16.3
	S.C.	12.5	12.8	11.2	11.1	8.9	13.0	12.9	11.9	11.9	9.3	13.6	13.0	12.5	12.6	9.7
	K.W.	1.99	1.98	1.99	1.98	1.96	1.98	1.97	1.98	1.97	1.95	1.96	1.96	1.98	1.96	1.94

NOTE: ALL CAPACITIES INCLUDE INDOOR FAN HEAT. KW VALUES ARE FOR THE SYSTEM (OUTDOOR + INDOOR).

Multipliers for determining the performance with other indoor sections.

NOTE: For dry bulb temperatures different than those listed (between 73-87 °F), sensible capacity increases by 1060 BTUH per 1000 CFM per degree above the listed temperature and decreases by 1060 BTUH per 1000 CFM per degree below the listed temperature.

LOW CFM

Air Handler	Coil	T.C.	S.C.	KW
-	FC/MC/PC48	0.96	0.96	1.03
AHV24B	-	0.96	0.96	1.08
AHV30B	-	0.97	0.98	1.08
AHV36C	-	0.98	0.99	1.05
MV12B	FC/MC43B	1.00	1.01	1.02
MV12D	FC/MC48D	1.00	1.00	1.00
MV12D	FC/MC60D	1.00	1.01	1.00

Furnace	Coil	T.C.	S.C.	KW
T*9V*C20	UC48C	1.03	1.04	0.98
TM8X080C16MP11	FC/MC/PC43C	1.00	1.01	1.02
TM8X080C16MP11	FC/MC/PC48C	1.00	1.01	1.00
TM8X080C16MP11	FC/PC60C	1.00	1.01	1.00
TM8X080C16MP11	UC48C	1.02	1.02	0.99
TM8X080C16MP11	UC60C	1.00	1.01	1.00
TM8X100C16MP11	FC/MC/PC43C	1.00	1.01	1.02
TM8X100C16MP11	FC/MC/PC48C	1.00	1.01	1.00
TM8X100C16MP11	FC/PC60C	1.00	1.01	1.00
TM8X100C16MP11	UC48C	1.02	1.02	0.99
TM8X100C16MP11	UC60C	1.00	1.01	1.00
TMLX080C16MP11	FC/MC/PC43C	1.00	1.01	1.02
TMLX080C16MP11	FC/MC/PC48C	1.00	1.01	1.00
TMLX080C16MP11	FC/PC60C	1.00	1.01	1.00
TMLX080C16MP11	UC48C	1.02	1.02	0.99
TMLX080C16MP11	UC60C	1.00	1.01	1.00
TMLX100C16MP11	FC/MC/PC43C	1.00	1.01	1.02
TMLX100C16MP11	FC/MC/PC48C	1.00	1.01	1.00
TMLX100C16MP11	FC/PC60C	1.00	1.01	1.00
TMLX100C16MP11	UC48C	1.02	1.02	0.99
TMLX100C16MP11	UC60C	1.00	1.01	1.00

Furnace	Coil	T.C.	S.C.	KW
T*(8,L)V*A12	FC/MC/PC37A	1.00	1.00	1.03
T*(8,L)V*B12	FC/MC/PC43B	0.98	0.99	1.05
T*(8,L)V*C16	FC/MC/PC43C	1.01	1.01	1.02
T*9V*A10	FC/MC/PC37A	0.98	0.99	1.04
T*9V*B12	FC/MC/PC43B	0.99	1.00	1.04
T*9V*C16	FC/MC/PC48C	1.01	1.01	1.00
T*9V*C16	FC/PC60C	1.00	1.01	1.00
T*9V*C16	UC48C	1.03	1.04	0.98
T*9V*C16	UC60C	1.00	1.01	1.00
T*9V*C20	FC/MC/PC43C	1.01	1.01	1.02
T*9V*C20	FC/MC/PC48C	1.01	1.01	1.00

COOLING PERFORMANCE DATA - HIGH CFM 2-STAGE OPERATION

OUTDOOR UNIT MODEL NO.		HL8B024F4C														
INDOOR COIL MODEL NO.		FC/MC48D + MV12D														
AIR TEMP. ENTERING OUTDOOR UNIT (°F)	ID CFM	800					900					1000				
	ID DB (°F)	80	80	75	80	80	80	80	75	80	80	80	80	75	80	80
	ID WB (°F)	57	62	62	67	72	57	62	62	67	72	57	62	62	67	72
65	T.C.	24.7	23.9	24.3	26.6	29.3	25.0	24.7	25.1	27.3	29.9	25.3	25.4	25.9	28.0	30.4
	S.C.	22.0	21.3	18.2	17.9	14.3	23.0	22.6	19.4	19.2	15.2	23.9	23.9	20.6	20.4	16.2
	K.W.	1.18	1.16	1.17	1.17	1.19	1.18	1.16	1.17	1.16	1.18	1.20	1.17	1.17	1.17	1.19
75	T.C.	24.0	23.1	23.3	25.5	28.0	24.6	24.0	24.0	26.2	28.5	25.1	24.8	24.7	26.9	29.0
	S.C.	21.3	20.7	17.9	17.5	13.9	22.3	21.9	19.0	18.8	14.8	23.2	23.1	20.1	20.0	15.7
	K.W.	1.35	1.34	1.35	1.35	1.36	1.35	1.34	1.35	1.35	1.36	1.36	1.35	1.35	1.35	1.38
85	T.C.	23.3	22.4	22.2	24.4	26.6	24.1	23.2	22.9	25.1	27.2	25.0	24.1	23.5	25.8	27.7
	S.C.	20.7	20.2	17.5	17.1	13.5	21.6	21.3	18.6	18.4	14.4	22.4	22.3	19.7	19.7	15.2
	K.W.	1.52	1.52	1.53	1.54	1.54	1.52	1.52	1.52	1.53	1.55	1.53	1.53	1.53	1.53	1.56
95	T.C.	22.6	21.6	21.2	23.3	25.3	23.7	22.5	21.7	24.0	25.8	24.8	23.5	22.2	24.7	26.3
	S.C.	20.0	19.7	17.2	16.6	13.1	20.8	20.6	18.3	18.0	13.9	21.7	21.5	19.3	19.3	14.7
	K.W.	1.70	1.70	1.71	1.72	1.72	1.69	1.70	1.70	1.71	1.73	1.69	1.71	1.71	1.72	1.74
105	T.C.	21.6	20.5	19.8	21.7	23.7	22.6	21.4	20.3	22.4	24.2	23.6	22.2	20.8	23.1	24.7
	S.C.	19.0	18.6	16.5	16.1	12.6	19.8	19.5	17.5	17.4	13.5	20.6	20.3	18.5	18.7	14.3
	K.W.	1.97	1.97	1.97	1.98	1.98	1.96	1.96	1.97	1.98	1.98	1.96	1.97	1.98	1.98	2.00
115	T.C.	20.6	19.3	18.5	20.1	22.2	21.6	20.2	19.0	20.9	22.7	22.5	21.0	19.5	21.6	23.1
	S.C.	18.1	17.6	15.7	15.5	12.1	18.9	18.4	16.8	16.8	13.0	19.6	19.2	17.8	18.0	13.8
	K.W.	2.24	2.23	2.23	2.24	2.24	2.23	2.23	2.24	2.23	2.24	2.23	2.23	2.25	2.24	2.24
125	T.C.	19.7	18.2	17.2	18.6	20.7	20.6	19.1	17.7	19.3	21.1	21.4	19.8	18.2	20.0	21.5
	S.C.	17.2	16.5	15.0	15.0	11.7	17.9	17.3	16.0	16.2	12.5	18.6	18.0	17.1	17.3	13.4
	K.W.	2.50	2.49	2.49	2.49	2.49	2.49	2.49	2.50	2.49	2.49	2.49	2.49	2.52	2.49	2.49

NOTE: ALL CAPACITIES INCLUDE INDOOR FAN HEAT. KW VALUES ARE FOR THE SYSTEM (OUTDOOR + INDOOR).

Multipliers for determining the performance with other indoor sections.

NOTE: For dry bulb temperatures different than those listed (between 73-87 °F), sensible capacity increases by 1060 BTUH per 1000 CFM per degree above the listed temperature and decreases by 1060 BTUH per 1000 CFM per degree below the listed temperature.

HIGH CFM

Air Handler	Coil	T.C.	S.C.	KW
-	FC/MC/PC48	0.95	0.91	1.13
AHV24B	-	0.94	0.87	1.01
AHV30B	-	0.95	0.90	1.02
AHV36C	-	0.96	0.91	0.99
MV12B	FC/MC43B	0.98	0.93	1.01
MV12D	FC/MC48D	1.00	1.00	1.00
MV12D	FC/MC60D	0.99	0.96	0.99

Furnace	Coil	T.C.	S.C.	KW
T*(8,L)V*A12	FC/MC/PC37A	0.96	0.91	1.01
T*(8,L)V*B12	FC/MC/PC43B	0.97	0.93	1.00
T*(8,L)V*C16	FC/MC/PC43C	0.97	0.92	1.00
T*9V*A10	FC/MC/PC37A	0.96	0.91	1.07
T*9V*B12	FC/MC/PC43B	0.97	0.93	1.02
T*9V*C16	FC/MC/PC48C	0.99	0.98	1.03
T*9V*C16	FC/PC60C	1.00	0.99	1.02
T*9V*C16	UC48C	0.99	0.99	1.03
T*9V*C16	UC60C	1.00	0.99	1.02
T*9V*C20	FC/MC/PC43C	0.99	0.99	1.03
T*9V*C20	FC/MC/PC48C	0.99	0.98	1.03
T*9V*C20	UC48C	0.99	0.99	1.03

Furnace	Coil	T.C.	S.C.	KW
TM8X080C16MP11	FC/MC/PC43C	0.97	0.92	1.06
TM8X080C16MP11	FC/MC/PC48C	0.97	0.92	1.06
TM8X080C16MP11	FC/PC60C	0.98	0.94	1.07
TM8X080C16MP11	UC48C	0.96	0.92	1.05
TM8X080C16MP11	UC60C	0.98	0.94	1.07
TM8X100C16MP11	FC/MC/PC43C	0.97	0.92	1.06
TM8X100C16MP11	FC/MC/PC48C	0.97	0.92	1.06
TM8X100C16MP11	FC/PC60C	0.98	0.94	1.07
TM8X100C16MP11	UC48C	0.96	0.92	1.05
TM8X100C16MP11	UC60C	0.98	0.94	1.07
TMLX080C16MP11	FC/MC/PC43C	0.97	0.92	1.06
TMLX080C16MP11	FC/MC/PC48C	0.97	0.92	1.06
TMLX080C16MP11	FC/PC60C	0.98	0.94	1.07
TMLX080C16MP11	UC48C	0.96	0.92	1.05
TMLX080C16MP11	UC60C	0.98	0.94	1.07
TMLX100C16MP11	FC/MC/PC43C	0.97	0.92	1.06
TMLX100C16MP11	FC/MC/PC48C	0.97	0.92	1.06
TMLX100C16MP11	FC/PC60C	0.98	0.94	1.07
TMLX100C16MP11	UC48C	0.96	0.92	1.05
TMLX100C16MP11	UC60C	0.98	0.94	1.07

COOLING PERFORMANCE DATA - LOW CFM 1-STAGE OPERATION																
OUTDOOR UNIT MODEL NO.		HL8B036F4C														
INDOOR COIL MODEL NO.		FC/MC62D + MV12D														
AIR TEMP. ENTERING OUTDOOR UNIT (°F)	ID CFM	725					775					825				
	ID DB (°F)	80	80	75	80	80	80	80	75	80	80	80	80	75	80	80
	ID WB (°F)	57	62	62	67	72	57	62	62	67	72	57	62	62	67	72
65	T.C.	28.8	26.6	26.9	29.2	32.6	29.6	27.4	27.2	30.0	33.1	30.4	28.2	27.4	30.7	33.6
	S.C.	25.1	22.7	19.4	19.5	15.9	25.7	23.9	19.9	20.3	16.0	26.2	25.2	20.5	21.0	16.2
	K.W.	1.18	1.18	1.18	1.16	1.15	1.19	1.19	1.20	1.17	1.16	1.21	1.20	1.22	1.18	1.17
75	T.C.	27.4	25.4	25.5	28.0	31.2	28.0	26.0	25.8	28.5	31.6	28.7	26.6	26.1	29.1	32.0
	S.C.	24.0	22.3	18.8	18.9	15.2	24.6	23.4	19.5	19.7	15.5	25.2	24.4	20.1	20.4	15.8
	K.W.	1.37	1.37	1.37	1.35	1.33	1.38	1.38	1.39	1.36	1.34	1.40	1.40	1.41	1.38	1.36
85	T.C.	26.0	24.2	24.0	26.7	29.7	26.5	24.6	24.4	27.1	30.0	27.0	25.0	24.8	27.5	30.3
	S.C.	23.0	21.9	18.3	18.4	14.5	23.5	22.8	19.0	19.1	15.0	24.1	23.7	19.7	19.8	15.5
	K.W.	1.56	1.56	1.56	1.54	1.52	1.57	1.58	1.58	1.56	1.53	1.58	1.59	1.59	1.57	1.54
95	T.C.	24.6	23.0	22.6	25.5	28.3	25.0	23.2	23.1	25.7	28.5	25.3	23.4	23.5	25.9	28.7
	S.C.	21.9	21.5	17.7	17.8	13.9	22.5	22.3	18.5	18.5	14.5	23.0	23.0	19.3	19.2	15.1
	K.W.	1.76	1.76	1.76	1.74	1.71	1.76	1.77	1.77	1.75	1.72	1.77	1.78	1.78	1.76	1.73
105	T.C.	22.5	21.4	20.9	23.7	26.1	22.8	21.7	21.3	23.8	26.4	23.1	21.9	21.6	24.0	26.7
	S.C.	20.6	20.3	17.0	17.1	13.3	21.1	21.0	17.7	17.7	13.8	21.6	21.6	18.4	18.4	14.4
	K.W.	2.02	2.02	2.02	2.00	1.97	2.03	2.03	2.03	2.01	1.99	2.04	2.04	2.05	2.03	2.00
115	T.C.	20.4	19.9	19.3	21.9	24.1	20.7	20.1	19.6	22.0	24.4	21.0	20.4	19.8	22.1	24.8
	S.C.	19.3	19.2	16.2	16.3	12.7	19.8	19.7	16.9	17.0	13.1	20.2	20.3	17.5	17.7	13.6
	K.W.	2.27	2.27	2.28	2.26	2.23	2.28	2.28	2.29	2.27	2.24	2.29	2.30	2.30	2.28	2.26
125	T.C.	18.3	18.3	17.7	20.1	22.0	18.6	18.6	17.8	20.2	22.4	18.9	18.9	17.9	20.2	22.8
	S.C.	18.0	18.0	15.5	15.6	12.1	18.5	18.5	16.1	16.3	12.5	18.9	19.0	16.6	16.9	12.9
	K.W.	2.53	2.53	2.54	2.52	2.49	2.54	2.54	2.55	2.53	2.50	2.55	2.55	2.56	2.54	2.52

NOTE: ALL CAPACITIES INCLUDE INDOOR FAN HEAT. KW VALUES ARE FOR THE SYSTEM (OUTDOOR + INDOOR).

Multipliers for determining the performance with other indoor sections.

NOTE: For dry bulb temperatures different than those listed (between 73-87 °F), sensible capacity increases by 1060 BTUH per 1000 CFM per degree above the listed temperature and decreases by 1060 BTUH per 1000 CFM per degree below the listed temperature.

LOW CFM

Air Handler	Coil	T.C.	S.C.	KW
-	FC/MC62	1.01	1.03	1.21
AHE42D	-	0.97	0.95	1.00
AHV36C	-	1.00	1.01	1.01
AHV42D	-	1.01	1.01	0.99
AHV48D	-	1.02	1.03	0.99
MV12B	FC/MC43B	1.01	1.01	1.03
MV12D	FC/MC48D	1.01	1.01	1.01
MV12D	FC/MC60D	0.99	0.97	1.02
MV12D	FC/MC62D	1.00	1.00	1.00
MV12D	FC64D	1.04	1.04	1.00
MV16C	FC/MC43C	0.99	0.99	1.04
MV16C	FC/MC48C	1.01	1.01	1.01
MV20D	FC/MC48D	1.02	1.05	1.02
MV20D	FC/MC60D	1.03	1.04	1.02
MV20D	FC/MC62D	1.02	1.05	1.02
MV20D	FC64D	1.06	1.08	1.00
MX12BN21	FC/MC43B	0.99	0.99	1.04
MX12DN21	FC/MC48D	1.02	1.03	1.00
MX12DN21	FC/MC60D	1.02	1.03	1.00
MX12DN21	FC64D	1.06	1.10	0.99

Continued on next page.

Furnace	Coil	T.C.	S.C.	KW
T*(8,L)V*A12	FC/MC/PC37A	0.97	0.95	1.06
T*(8,L)V*B12	FC/MC/PC43B	1.01	1.03	1.07
T*(8,L)V*C16	FC/MC/PC43C	0.99	0.99	1.04
T*(8,L)V*C16	FC/MC/PC48C	0.98	0.96	1.03
T*(8,L)V*C16	FC/PC60C	0.99	0.97	1.02
T*(8,L)V*C16	UC48C	0.99	1.00	1.04
T*(8,L)V*C16	UC60C	0.99	1.00	0.99
T*(8,L)V*C20	FC/MC/PC43C	0.99	0.97	1.03
T*(8,L)V*C20	FC/MC/PC48C	0.98	0.96	1.02
T*(8,L)V*C20	FC/PC60C	1.01	1.01	1.03
T*(8,L)V*C20	UC48C	0.97	0.94	1.03
T*(8,L)V*C20	UC60C	0.99	1.00	0.99
T*9V*B12	FC/MC/PC43B	1.01	1.01	1.06
T*9V*C16	FC/MC/PC43C	1.01	1.01	1.05
T*9V*C16	FC/MC/PC48C	1.01	1.01	1.01
T*9V*C16	FC/PC60C	1.01	1.01	1.05
T*9V*C16	UC48C	0.99	0.98	1.01
T*9V*C16	UC60C	1.00	1.00	1.04
T*9V*C20	FC/MC/PC43C	0.99	0.99	1.03
T*9V*C20	FC/MC/PC48C	0.99	0.97	1.04
T*9V*C20	FC/PC60C	1.00	0.99	1.02
T*9V*C20	UC48C	0.98	0.96	1.05
T*9V*C20	UC60C	0.99	0.98	1.03
T*9V*D20	FC/MC/PC48D	1.01	1.02	1.04
T*9V*D20	FC/MC/PC60D	1.02	1.02	1.03
T*9V*D20	FC/MC62D	1.01	1.03	1.04
T*9V*D20	FC64D	1.05	1.07	1.03
T*9V*D20	UC48D	1.00	1.01	1.04
T*9V*D20	UC60D	1.00	1.01	1.03
TM8X060A12MP11	FC/MC/PC37A	0.99	0.99	1.04
TM8X080B12MP11	FC/MC/PC43B	0.99	0.99	1.04
TM8X080C16MP11	FC/MC/PC43C	0.99	0.99	1.04
TM8X080C16MP11	FC/MC/PC48C	1.01	1.01	1.01
TM8X080C16MP11	FC/MC/PC48D	1.01	1.01	1.01
TM8X080C16MP11	FC/MC/PC60D	1.01	1.01	1.00
TM8X080C16MP11	FC/MC62D	1.01	1.01	1.01
TM8X080C16MP11	FC/PC60C	1.01	1.00	1.00
TM8X080C16MP11	FC64D	1.04	1.04	1.00
TM8X080C16MP11	UC48C	0.99	0.98	1.01
TM8X080C16MP11	UC48D	0.99	0.98	1.01
TM8X080C16MP11	UC60C	0.99	1.00	0.99
TM8X080C16MP11	UC60D	0.99	1.00	0.99
TM8X100C16MP11	FC/MC/PC43C	0.99	0.99	1.04
TM8X100C16MP11	FC/MC/PC48C	1.01	1.01	1.01
TM8X100C16MP11	FC/MC/PC48D	1.01	1.01	1.01
TM8X100C16MP11	FC/MC/PC60D	1.01	1.01	1.00
TM8X100C16MP11	FC/MC62D	1.01	1.01	1.01
TM8X100C16MP11	FC/PC60C	1.01	1.00	1.00
TM8X100C16MP11	FC64D	1.04	1.04	1.00
TM8X100C16MP11	UC48C	0.99	0.98	1.01
TM8X100C16MP11	UC48D	0.99	0.98	1.01
TM8X100C16MP11	UC60C	0.99	1.00	0.99
TM8X100C16MP11	UC60D	0.99	1.00	0.99
TM8X100C16MP11	FC/MC/PC43C	0.99	0.99	1.04
TM8X100C16MP11	FC/MC/PC48C	1.01	1.01	1.01
TM8X100C16MP11	FC/MC/PC48D	1.01	1.01	1.01
TM8X100C16MP11	FC/MC/PC60D	1.01	1.01	1.00
TM8X100C16MP11	FC/MC62D	1.01	1.01	1.01
TM8X100C16MP11	FC/PC60C	1.01	1.00	1.00
TM8X100C16MP11	FC64D	1.04	1.04	1.00
TM8X100C16MP11	UC48C	0.99	0.98	1.01

Furnace	Coil	T.C.	S.C.	KW
TM8X100C16MP11	UC48D	0.99	0.98	1.01
TM8X100C16MP11	UC60C	0.99	1.00	0.99
TM8X100C16MP11	UC60D	0.99	1.00	0.99
TMLX060A12MP11	FC/MC/PC37A	0.99	0.99	1.04
TMLX080B12MP11	FC/MC/PC43B	0.99	0.99	1.04
TMLX080C16MP11	FC/MC/PC43C	0.99	0.99	1.04
TMLX080C16MP11	FC/MC/PC48C	1.01	1.01	1.01
TMLX080C16MP11	FC/MC/PC48D	1.01	1.01	1.01
TMLX080C16MP11	FC/MC/PC60D	1.01	1.01	1.00
TMLX080C16MP11	FC/MC62D	1.01	1.01	1.01
TMLX080C16MP11	FC/PC60C	1.01	1.00	1.00
TMLX080C16MP11	FC64D	1.04	1.04	1.00
TMLX080C16MP11	UC48C	0.99	0.98	1.01
TMLX080C16MP11	UC48D	0.99	0.98	1.01
TMLX080C16MP11	UC60C	0.99	1.00	0.99
TMLX080C16MP11	UC60D	0.99	1.00	0.99
TMLX100C16MP11	FC/MC/PC43C	0.99	0.99	1.04
TMLX100C16MP11	FC/MC/PC48C	1.01	1.01	1.01
TMLX100C16MP11	FC/MC/PC48D	1.01	1.01	1.01
TMLX100C16MP11	FC/MC/PC60D	1.01	1.01	1.00
TMLX100C16MP11	FC/MC62D	1.01	1.01	1.01
TMLX100C16MP11	FC/PC60C	1.01	1.00	1.00
TMLX100C16MP11	FC64D	1.04	1.04	1.00
TMLX100C16MP11	UC48C	0.99	0.98	1.01
TMLX100C16MP11	UC48D	0.99	0.98	1.01
TMLX100C16MP11	UC60C	0.99	1.00	0.99
TMLX100C16MP11	UC60D	0.99	1.00	0.99
TM9E060B12MP11	FC/MC/PC43B	0.98	0.96	1.02
TM9E080B12MP11	FC/MC/PC43B	0.98	0.96	1.02
TM9E080C16MP11	FC/MC/PC48D	1.01	1.01	1.01
TM9E080C16MP11	FC/MC62D	1.00	0.99	1.01
TM9E080C16MP11	FC64D	1.04	1.04	1.00
TM9E080C16MP11	UC48D	0.99	0.98	1.01
TM9E100C16MP11	FC/MC/PC48D	1.01	1.01	1.01
TM9E100C16MP11	FC/MC62D	1.00	0.99	1.01
TM9E100C16MP11	FC64D	1.04	1.04	1.00
TM9E100C16MP11	UC48D	0.99	0.98	1.01
TM9X060B12MP11	FC/MC/PC43B	0.98	0.96	1.02
TM9X080B12MP11	FC/MC/PC43B	0.98	0.96	1.02
TM9X080C16MP11	FC/MC/PC48D	1.01	1.01	1.01
TM9X080C16MP11	FC/MC62D	1.00	0.99	1.01
TM9X080C16MP11	FC64D	1.04	1.04	1.00
TM9X080C16MP11	UC48D	0.99	0.98	1.01
TM9X100C16MP11	FC/MC/PC48D	1.01	1.01	1.01
TM9X100C16MP11	FC/MC62D	1.00	0.99	1.01
TM9X100C16MP11	FC64D	1.04	1.04	1.00
TM9X100C16MP11	UC48D	0.99	0.98	1.01

COOLING PERFORMANCE DATA - HIGH CFM 2-STAGE OPERATION																
OUTDOOR UNIT MODEL NO.		HL8B036F4C														
INDOOR COIL MODEL NO.		FC/MC62D + MV12D														
AIR TEMP. ENTERING OUTDOOR UNIT (°F)	ID CFM	1125					1225					1325				
	ID DB (°F)	80	80	75	80	80	80	80	75	80	80	80	80	75	80	80
	ID WB (°F)	57	62	62	67	72	57	62	62	67	72	57	62	62	67	72
65	T.C.	40.2	37.6	37.8	42.4	46.0	40.7	38.2	38.2	42.3	45.8	41.1	38.8	38.6	42.3	45.7
	S.C.	35.4	32.8	27.5	27.2	21.9	36.3	34.1	28.4	28.2	22.3	37.2	35.5	29.3	29.2	22.7
	K.W.	1.86	1.88	1.87	1.91	1.93	1.92	1.93	1.93	1.96	1.98	1.98	1.99	1.99	2.02	2.04
75	T.C.	38.7	36.1	36.1	40.1	43.9	39.2	36.6	36.5	40.2	43.8	39.6	37.1	36.9	40.3	43.6
	S.C.	34.0	32.1	26.8	26.7	21.3	34.9	33.4	27.8	27.7	21.8	35.7	34.6	28.8	28.6	22.3
	K.W.	2.08	2.09	2.08	2.12	2.14	2.13	2.14	2.13	2.17	2.19	2.19	2.20	2.19	2.22	2.24
85	T.C.	37.3	34.6	34.3	37.8	41.9	37.7	35.0	34.7	38.1	41.8	38.1	35.4	35.2	38.3	41.6
	S.C.	32.6	31.5	26.0	26.2	20.7	33.4	32.6	27.2	27.2	21.3	34.2	33.7	28.3	28.1	21.8
	K.W.	2.29	2.29	2.28	2.32	2.34	2.34	2.35	2.34	2.37	2.39	2.40	2.41	2.40	2.43	2.45
95	T.C.	35.8	33.0	32.5	35.6	39.8	36.2	33.4	33.0	36.0	39.7	36.7	33.6	33.4	36.4	39.6
	S.C.	31.2	30.9	25.3	25.7	20.0	31.9	31.9	26.6	26.6	20.7	32.6	32.8	27.9	27.6	21.4
	K.W.	2.50	2.50	2.49	2.52	2.55	2.55	2.56	2.54	2.57	2.60	2.61	2.62	2.60	2.63	2.65
105	T.C.	32.8	31.1	30.5	33.3	37.3	33.4	31.5	30.9	33.7	37.2	33.9	32.0	31.3	34.0	37.2
	S.C.	29.5	29.4	24.5	24.8	19.2	30.2	30.2	25.8	25.8	19.8	30.9	31.0	27.0	26.8	20.4
	K.W.	2.81	2.81	2.80	2.83	2.85	2.86	2.86	2.84	2.87	2.90	2.93	2.92	2.90	2.93	2.95
115	T.C.	29.9	29.2	28.5	31.1	34.8	30.6	29.8	28.8	31.5	34.8	31.2	30.3	29.2	31.8	34.8
	S.C.	27.9	28.0	23.8	24.0	18.4	28.5	28.7	25.0	25.0	19.0	29.1	29.3	26.1	26.0	19.5
	K.W.	3.11	3.10	3.09	3.12	3.14	3.17	3.15	3.14	3.17	3.19	3.23	3.21	3.20	3.23	3.24
125	T.C.	27.1	27.2	26.5	28.9	32.4	27.8	28.0	26.8	29.2	32.4	28.5	28.7	27.1	29.5	32.4
	S.C.	26.3	26.6	23.1	23.1	17.6	26.8	27.1	24.1	24.2	18.1	27.4	27.6	25.2	25.2	18.6
	K.W.	3.40	3.39	3.38	3.41	3.43	3.47	3.44	3.43	3.46	3.48	3.54	3.50	3.49	3.52	3.53

NOTE: ALL CAPACITIES INCLUDE INDOOR FAN HEAT. KW VALUES ARE FOR THE SYSTEM (OUTDOOR + INDOOR).

Multipliers for determining the performance with other indoor sections.

NOTE: For dry bulb temperatures different than those listed (between 73-87 °F), sensible capacity increases by 1060 BTUH per 1000 CFM per degree above the listed temperature and decreases by 1060 BTUH per 1000 CFM per degree below the listed temperature.

HIGH CFM

Air Handler	Coil	T.C.	S.C.	KW
-	FC/MC62	0.98	0.96	1.10
AHE42D	-	0.98	0.96	1.00
AHV36C	-	0.98	0.96	1.03
AHV42D	-	0.98	0.96	1.00
AHV48D	-	0.99	0.95	1.01
MV12B	FC/MC43B	0.98	0.97	1.04
MV12D	FC/MC48D	0.98	0.96	1.00
MV12D	FC/MC60D	0.98	0.94	1.01
MV12D	FC/MC62D	1.00	1.00	1.00
MV12D	FC64D	1.02	1.00	1.00
MV16C	FC/MC43C	0.98	0.96	1.02
MV16C	FC/MC48C	0.98	0.95	1.01
MV20D	FC/MC48D	1.00	1.01	1.02
MV20D	FC/MC60D	1.01	1.00	1.02
MV20D	FC/MC62D	1.01	1.03	1.01
MV20D	FC64D	1.04	1.06	1.02
MX12BN21	FC/MC43B	0.97	0.92	1.04
MX12DN21	FC/MC48D	0.98	0.94	1.00
MX12DN21	FC/MC60D	0.99	0.95	0.99
MX12DN21	FC64D	1.02	1.00	1.00

Continued on next page.

Furnace	Coil	T.C.	S.C.	KW
T*(8,L)V*A12	FC/MC/PC37A	0.96	0.92	1.08
T*(8,L)V*B12	FC/MC/PC43B	0.98	0.97	1.10
T*(8,L)V*C16	FC/MC/PC43C	0.98	0.95	1.03
T*(8,L)V*C16	FC/MC/PC48C	0.99	0.97	1.03
T*(8,L)V*C16	FC/PC60C	0.98	0.94	1.02
T*(8,L)V*C16	UC48C	0.99	0.97	1.03
T*(8,L)V*C16	UC60C	0.98	0.95	1.01
T*(8,L)V*C20	FC/MC/PC43C	0.98	0.95	1.03
T*(8,L)V*C20	FC/MC/PC48C	0.98	0.94	1.01
T*(8,L)V*C20	FC/PC60C	0.99	0.97	1.03
T*(8,L)V*C20	UC48C	0.99	0.95	1.01
T*(8,L)V*C20	UC60C	0.98	0.95	1.01
T*9V*B12	FC/MC/PC43B	0.97	0.94	1.06
T*9V*C16	FC/MC/PC43C	0.98	0.97	1.05
T*9V*C16	FC/MC/PC48C	0.97	0.94	1.03
T*9V*C16	FC/PC60C	0.99	0.97	1.04
T*9V*C16	UC48C	0.98	0.94	1.04
T*9V*C16	UC60C	0.98	0.97	1.05
T*9V*C20	FC/MC/PC43C	0.98	0.95	1.03
T*9V*C20	FC/MC/PC48C	1.00	1.00	1.08
T*9V*C20	FC/PC60C	1.01	1.00	1.06
T*9V*C20	UC48C	1.00	1.01	1.08
T*9V*C20	UC60C	0.99	1.00	1.07
T*9V*D20	FC/MC/PC48D	0.99	0.98	1.03
T*9V*D20	FC/MC/PC60D	0.99	0.97	1.03
T*9V*D20	FC/MC62D	0.99	1.00	1.03
T*9V*D20	FC64D	1.02	1.02	1.04
T*9V*D20	UC48D	0.99	0.98	1.03
T*9V*D20	UC60D	0.98	0.97	1.04
TM8X060A12MP11	FC/MC/PC37A	0.96	0.92	1.06
TM8X080B12MP11	FC/MC/PC43B	0.96	0.92	1.06
TM8X080C16MP11	FC/MC/PC43C	0.97	0.92	1.02
TM8X080C16MP11	FC/MC/PC48C	0.98	0.95	1.01
TM8X080C16MP11	FC/MC/PC48D	0.98	0.95	1.01
TM8X080C16MP11	FC/MC/PC60D	0.98	0.95	1.02
TM8X080C16MP11	FC/MC62D	0.99	0.97	1.03
TM8X080C16MP11	FC/PC60C	0.98	0.95	1.02
TM8X080C16MP11	FC64D	1.01	1.00	1.03
TM8X080C16MP11	UC48C	0.98	0.95	1.02
TM8X080C16MP11	UC48D	0.98	0.95	1.02
TM8X080C16MP11	UC60C	0.98	0.95	1.03
TM8X080C16MP11	UC60D	0.98	0.95	1.01
TM8X100C16MP11	FC/MC/PC43C	0.97	0.92	1.02
TM8X100C16MP11	FC/MC/PC48C	0.98	0.95	1.01
TM8X100C16MP11	FC/MC/PC48D	0.98	0.95	1.01
TM8X100C16MP11	FC/MC/PC60D	0.98	0.95	1.02
TM8X100C16MP11	FC/MC62D	0.99	0.97	1.03
TM8X100C16MP11	FC/PC60C	0.98	0.95	1.02
TM8X100C16MP11	FC64D	1.01	1.00	1.03
TM8X100C16MP11	UC48C	0.98	0.95	1.02

Furnace	Coil	T.C.	S.C.	KW
TM8X100C16MP11	UC48D	0.98	0.95	1.02
TM8X100C16MP11	UC60C	0.98	0.95	1.03
TM8X100C16MP11	UC60D	0.98	0.95	1.01
TMLX060A12MP11	FC/MC/PC37A	0.96	0.92	1.06
TMLX080B12MP11	FC/MC/PC43B	0.96	0.92	1.06
TMLX080C16MP11	FC/MC/PC43C	0.97	0.92	1.02
TMLX080C16MP11	FC/MC/PC48C	0.98	0.95	1.01
TMLX080C16MP11	FC/MC/PC48D	0.98	0.95	1.01
TMLX080C16MP11	FC/MC/PC60D	0.98	0.95	1.02
TMLX080C16MP11	FC/MC62D	0.99	0.97	1.03
TMLX080C16MP11	FC/PC60C	0.98	0.95	1.02
TMLX080C16MP11	FC64D	1.01	1.00	1.03
TMLX080C16MP11	UC48C	0.98	0.95	1.02
TMLX080C16MP11	UC48D	0.98	0.95	1.02
TMLX080C16MP11	UC60C	0.98	0.95	1.03
TMLX080C16MP11	UC60D	0.98	0.95	1.01
TMLX100C16MP11	FC/MC/PC43C	0.97	0.92	1.02
TMLX100C16MP11	FC/MC/PC48C	0.98	0.95	1.01
TMLX100C16MP11	FC/MC/PC48D	0.98	0.95	1.01
TMLX100C16MP11	FC/MC/PC60D	0.98	0.95	1.02
TMLX100C16MP11	FC/MC62D	0.99	0.97	1.03
TMLX100C16MP11	FC/PC60C	0.98	0.95	1.02
TMLX100C16MP11	FC64D	1.01	1.00	1.03
TMLX100C16MP11	UC48C	0.98	0.95	1.02
TMLX100C16MP11	UC48D	0.98	0.95	1.02
TMLX100C16MP11	UC60C	0.98	0.95	1.03
TMLX100C16MP11	UC60D	0.98	0.95	1.01
TM9E060B12MP11	FC/MC/PC43B	0.96	0.92	1.06
TM9E080B12MP11	FC/MC/PC43B	0.96	0.92	1.06
TM9E080C16MP11	FC/MC/PC48D	0.97	0.94	1.03
TM9E080C16MP11	FC/MC62D	0.98	0.97	1.04
TM9E080C16MP11	FC64D	1.01	0.99	1.03
TM9E080C16MP11	UC48D	0.98	0.94	1.04
TM9E100C16MP11	FC/MC/PC48D	0.97	0.94	1.03
TM9E100C16MP11	FC/MC62D	0.98	0.97	1.04
TM9E100C16MP11	FC64D	1.01	0.99	1.03
TM9E100C16MP11	UC48D	0.98	0.94	1.04
TM9X060B12MP11	FC/MC/PC43B	0.96	0.92	1.06
TM9X080B12MP11	FC/MC/PC43B	0.96	0.92	1.06
TM9X080C16MP11	FC/MC/PC48D	0.97	0.94	1.03
TM9X080C16MP11	FC/MC62D	0.98	0.97	1.04
TM9X080C16MP11	FC64D	1.01	0.99	1.03
TM9X080C16MP11	UC48D	0.98	0.94	1.04
TM9X100C16MP11	FC/MC/PC48D	0.97	0.94	1.03
TM9X100C16MP11	FC/MC62D	0.98	0.97	1.04
TM9X100C16MP11	FC64D	1.01	0.99	1.03
TM9X100C16MP11	UC48D	0.98	0.94	1.04

COOLING PERFORMANCE DATA - LOW CFM 1-STAGE OPERATION																
OUTDOOR UNIT MODEL NO.		HL8B048F4C														
INDOOR COIL MODEL NO.		FC/MC62D + MV20D														
AIR TEMP. ENTERING OUTDOOR UNIT (°F)	ID CFM	1025					1075					1125				
	ID DB (°F)	80	80	75	80	80	80	80	75	80	80	80	80	75	80	80
	ID WB (°F)	57	62	62	67	72	57	62	62	67	72	57	62	62	67	72
65	T.C.	35.9	36.7	36.8	40.8	44.3	36.8	37.3	36.9	40.9	44.8	39.7	39.7	38.9	43.2	47.9
	S.C.	33.8	31.0	26.6	26.5	21.1	34.5	31.9	27.2	27.2	21.5	36.7	33.5	28.5	28.7	22.7
	KW	1.58	1.57	1.56	1.55	1.52	1.59	1.59	1.58	1.56	1.54	1.32	1.32	1.32	1.29	1.26
75	T.C.	34.3	35.0	35.0	38.6	42.0	35.0	35.5	35.2	38.8	42.4	35.7	35.9	35.3	39.0	42.8
	S.C.	32.5	30.4	25.8	25.7	20.4	33.1	31.2	26.4	26.4	20.8	33.7	32.0	27.0	27.1	21.3
	KW	1.87	1.86	1.86	1.84	1.81	1.88	1.88	1.88	1.86	1.83	1.90	1.90	1.90	1.87	1.84
85	T.C.	32.7	33.3	33.2	36.3	39.7	33.2	33.7	33.4	36.6	40.0	31.8	32.2	31.8	34.7	37.7
	S.C.	31.1	29.7	24.9	24.9	19.6	31.7	30.5	25.6	25.6	20.1	30.7	30.5	25.5	25.5	19.8
	KW	2.16	2.15	2.16	2.13	2.10	2.17	2.17	2.17	2.15	2.12	2.47	2.47	2.48	2.46	2.43
95	T.C.	31.1	31.6	31.5	34.1	37.4	31.5	31.9	31.6	34.4	37.6	31.8	32.2	31.8	34.7	37.7
	S.C.	29.8	29.1	24.1	24.1	18.9	30.2	29.8	24.8	24.8	19.4	30.7	30.5	25.5	25.5	19.8
	KW	2.46	2.45	2.46	2.43	2.39	2.46	2.46	2.47	2.44	2.41	2.47	2.47	2.48	2.46	2.43
105	T.C.	29.1	29.3	28.9	31.7	34.8	29.5	29.7	29.1	31.9	34.9	29.8	30.0	29.2	32.2	35.0
	S.C.	27.9	27.6	23.0	23.2	18.1	28.4	28.2	23.6	23.8	18.5	28.8	28.8	24.3	24.4	18.9
	KW	2.84	2.83	2.85	2.82	2.78	2.85	2.85	2.86	2.83	2.80	2.86	2.87	2.88	2.85	2.82
115	T.C.	27.2	27.1	26.4	29.3	32.1	27.5	27.5	26.6	29.5	32.3	27.8	27.9	26.8	29.7	32.4
	S.C.	26.2	26.1	21.9	22.5	17.2	26.5	26.7	22.6	22.9	17.6	26.9	27.2	23.2	23.4	17.9
	KW	3.21	3.21	3.23	3.20	3.17	3.22	3.23	3.24	3.21	3.18	3.24	3.25	3.25	3.23	3.20
125	T.C.	25.3	25.0	23.9	27.0	29.5	25.6	25.4	24.1	27.1	29.6	25.9	25.9	24.3	27.3	29.7
	S.C.	24.4	24.7	20.9	21.7	16.3	24.7	25.1	21.5	22.0	16.6	25.1	25.6	22.1	22.4	16.9
	KW	3.59	3.59	3.60	3.58	3.56	3.60	3.60	3.62	3.59	3.57	3.61	3.62	3.63	3.61	3.58

NOTE: ALL CAPACITIES INCLUDE INDOOR FAN HEAT. KW VALUES ARE FOR THE SYSTEM (OUTDOOR + INDOOR).

Multipliers for determining the performance with other indoor sections.

NOTE: For dry bulb temperatures different than those listed (between 73-87 °F), sensible capacity increases by 1060 BTUH per 1000 CFM per degree above the listed temperature and decreases by 1060 BTUH per 1000 CFM per degree below the listed temperature.

LOW CFM

Air Handler	Coil	T.C.	S.C.	KW
-	FC/MC62	1.00	1.02	1.19
AHE60D	-	1.01	1.03	1.04
AHV48D	-	1.00	0.96	1.01
AHV60D	-	0.99	0.97	1.01
MV16C	FC/MC48C	1.00	0.98	1.03
MV16C	FC60C	1.00	0.97	1.03
MV20D	FC/MC48D	1.00	0.98	1.03
MV20D	FC/MC60D	1.00	0.97	1.03
MV20D	FC/MC62D	1.00	1.00	1.00
MV20D	FC64D	1.04	1.04	1.00
MX16CN21	FC/MC48C	1.00	0.98	1.03
MX16CN21	FC60C	1.00	0.97	1.03

Furnace	Coil	T.C.	S.C.	KW
T*(8,L)V*C20	FC/MC/PC60D	1.00	0.97	1.03
T*(8,L)V*C20	FC/MC62D	1.00	0.99	1.05
T*(8,L)V*C20	FC/PC60C	1.00	0.97	1.03
T*(8,L)V*C20	FC64D	1.04	1.04	1.00
T*(8,L)V*C20	UC48C	1.00	0.98	1.06
T*(8,L)V*C20	UC60C	0.97	0.95	1.03
T*9V*C16	FC/MC/PC48C	1.00	0.98	1.03
T*9V*C16	FC/MC/PC48D	1.00	0.98	1.03
T*9V*C16	FC/MC/PC60D	1.00	0.97	1.03
T*9V*C16	FC/MC62D	0.99	0.98	1.04
T*9V*C16	FC/PC60C	1.00	0.97	1.03
T*9V*C16	FC64D	1.04	1.04	1.00
T*9V*C16	UC48C	1.00	0.98	1.03
T*9V*C16	UC60C	0.97	0.95	1.02
T*9V*C20	FC/MC/PC48C	1.00	0.98	1.03
T*9V*C20	FC/MC/PC48D	1.00	0.98	1.03
T*9V*C20	FC/MC/PC60D	1.00	0.97	1.03
T*9V*C20	FC/MC62D	0.99	0.98	1.04
T*9V*C20	FC/PC60C	1.00	0.97	1.03
T*9V*C20	FC64D	1.04	1.04	1.00
T*9V*C20	UC48C	1.00	0.98	1.06
T*9V*C20	UC60C	0.99	0.97	1.06
T*9V*D20	FC/MC/PC48D	1.00	0.98	1.03

Continued on next page.

Furnace	Coil	T.C.	S.C.	KW
T*9V*D20	FC/MC/PC60D	1.00	0.97	1.03
T*9V*D20	FC/MC62D	1.00	1.00	1.06
T*9V*D20	FC64D	1.04	1.04	1.00
T*9V*D20	UC48D	1.00	0.98	1.06
T*9V*D20	UC60D	0.99	0.97	1.06
TM8X080C16MP11	FC/MC/PC48C	1.00	0.98	1.03
TM8X080C16MP11	FC/MC/PC48D	1.00	0.98	1.03
TM8X080C16MP11	FC/MC/PC60D	1.00	0.97	1.03
TM8X080C16MP11	FC/MC62D	0.99	0.98	1.02
TM8X080C16MP11	FC/PC60C	0.99	0.96	1.02
TM8X080C16MP11	FC64D	1.04	1.04	1.00
TM8X080C16MP11	UC48C	1.00	0.98	1.03
TM8X080C16MP11	UC48D	1.00	0.98	1.03
TM8X080C16MP11	UC60C	0.97	0.95	1.02
TM8X080C16MP11	UC60D	0.97	0.95	1.02
TM8X100C16MP11	FC/MC/PC48C	1.00	0.98	1.03
TM8X100C16MP11	FC/MC/PC48D	1.00	0.98	1.03
TM8X100C16MP11	FC/MC/PC60D	1.00	0.97	1.03
TM8X100C16MP11	FC/MC62D	0.99	0.98	1.02
TM8X100C16MP11	FC/PC60C	0.99	0.96	1.02
TM8X100C16MP11	FC64D	1.04	1.04	1.00
TM8X100C16MP11	UC48C	1.00	0.98	1.03
TM8X100C16MP11	UC48D	1.00	0.98	1.03
TM8X100C16MP11	UC60C	0.97	0.95	1.02
TM8X100C16MP11	UC60D	0.97	0.95	1.02
TM8X100C20MP11	FC/MC/PC48C	1.00	1.00	1.03
TM8X100C20MP11	FC/MC/PC48D	1.01	1.01	1.04
TM8X100C20MP11	FC/MC/PC60D	1.01	1.00	1.04
TM8X100C20MP11	FC/MC62D	1.01	1.02	1.04
TM8X100C20MP11	FC/PC60C	1.00	0.97	1.03
TM8X100C20MP11	UC48C	1.00	0.99	1.03
TM8X100C20MP11	UC48D	1.01	1.01	1.04
TM8X100C20MP11	UC60C	0.99	0.98	1.03
TM8X100C20MP11	UC60D	1.00	0.99	1.03
TM8X120C20MP11	FC/MC/PC48C	1.00	1.00	1.03
TM8X120C20MP11	FC/MC/PC48D	1.01	1.01	1.04
TM8X120C20MP11	FC/MC/PC60D	1.01	1.00	1.04
TM8X120C20MP11	FC/MC62D	1.01	1.02	1.04
TM8X120C20MP11	FC/PC60C	1.00	0.97	1.03
TM8X120C20MP11	UC48C	1.00	0.99	1.03
TM8X120C20MP11	UC48D	1.01	1.01	1.04
TM8X120C20MP11	UC60C	0.99	0.98	1.03
TM8X120C20MP11	UC60D	1.00	0.99	1.03
TMLX080C16MP11	FC/MC/PC48C	1.00	0.98	1.03
TMLX080C16MP11	FC/MC/PC48D	1.00	0.98	1.03
TMLX080C16MP11	FC/MC/PC60D	1.00	0.97	1.03
TMLX080C16MP11	FC/MC62D	0.99	0.98	1.02
TMLX080C16MP11	FC/PC60C	0.99	0.96	1.02
TMLX080C16MP11	FC64D	1.04	1.04	1.00
TMLX080C16MP11	UC48C	1.00	0.98	1.03
TMLX080C16MP11	UC48D	1.00	0.98	1.03
TMLX080C16MP11	UC60C	0.97	0.95	1.02
TMLX080C16MP11	UC60D	0.97	0.95	1.02
TMLX100C16MP11	FC/MC/PC48C	1.00	0.98	1.03
TMLX100C16MP11	FC/MC/PC48D	1.00	0.98	1.03
TMLX100C16MP11	FC/MC/PC60D	1.00	0.97	1.03

Furnace	Coil	T.C.	S.C.	KW
TMLX100C16MP11	FC/MC62D	0.99	0.98	1.02
TMLX100C16MP11	FC/PC60C	0.99	0.96	1.02
TMLX100C16MP11	FC64D	1.04	1.04	1.00
TMLX100C16MP11	UC48C	1.00	0.98	1.03
TMLX100C16MP11	UC48D	1.00	0.98	1.03
TMLX100C16MP11	UC60C	0.97	0.95	1.02
TMLX100C16MP11	UC60D	0.97	0.95	1.02
TMLX100C20MP11	FC/MC/PC48C	1.00	1.00	1.03
TMLX100C20MP11	FC/MC/PC48D	1.01	1.01	1.04
TMLX100C20MP11	FC/MC/PC60D	1.01	1.00	1.04
TMLX100C20MP11	FC/MC62D	1.01	1.02	1.04
TMLX100C20MP11	FC/PC60C	1.00	0.97	1.03
TMLX100C20MP11	UC48C	1.00	0.99	1.03
TMLX100C20MP11	UC48D	1.01	1.01	1.04
TMLX100C20MP11	UC60C	0.99	0.98	1.03
TMLX100C20MP11	UC60D	1.00	0.99	1.03
TMLX120C20MP11	FC/MC/PC48C	1.00	1.00	1.03
TMLX120C20MP11	FC/MC/PC48D	1.01	1.01	1.04
TMLX120C20MP11	FC/MC/PC60D	1.01	1.00	1.04
TMLX120C20MP11	FC/MC62D	1.01	1.02	1.04
TMLX120C20MP11	FC/PC60C	1.00	0.97	1.03
TMLX120C20MP11	UC48C	1.00	0.99	1.03
TMLX120C20MP11	UC48D	1.01	1.01	1.04
TMLX120C20MP11	UC60C	0.99	0.98	1.03
TMLX120C20MP11	UC60D	1.00	0.99	1.03
TM9E100C20MP11	FC/MC/PC48C	0.97	0.94	1.02
TM9E100C20MP11	FC/MC/PC48D	0.99	0.94	1.02
TM9E100C20MP11	FC/MC/PC60D	0.97	0.94	1.01
TM9E100C20MP11	FC/MC62D	0.97	0.95	1.01
TM9E100C20MP11	FC64D	1.01	0.99	1.00
TM9E100C20MP11	UC48C	0.97	0.94	1.02
TM9E100C20MP11	UC48D	0.99	0.95	1.03
TM9E100C20MP11	UC60D	0.97	0.93	1.03
TM9E120D20MP11	FC/MC/PC48D	0.99	0.95	1.02
TM9E120D20MP11	FC/MC/PC60D	0.99	0.95	1.01
TM9E120D20MP11	FC/MC62D	0.97	0.95	1.01
TM9E120D20MP11	FC64D	1.01	0.98	1.00
TM9E120D20MP11	UC48D	0.99	0.95	1.02
TM9E120D20MP11	UC60D	0.97	0.95	1.02
TM9X100C20MP11	FC/MC/PC48C	0.97	0.94	1.02
TM9X100C20MP11	FC/MC/PC48D	0.99	0.94	1.02
TM9X100C20MP11	FC/MC/PC60D	0.97	0.94	1.01
TM9X100C20MP11	FC/MC62D	0.97	0.95	1.01
TM9X100C20MP11	FC64D	1.01	0.99	1.00
TM9X100C20MP11	UC48C	0.97	0.94	1.02
TM9X100C20MP11	UC48D	0.99	0.95	1.03
TM9X100C20MP11	UC60D	0.97	0.93	1.03
TM9X120D20MP11	FC/MC/PC48D	0.99	0.95	1.02
TM9X120D20MP11	FC/MC/PC60D	0.99	0.95	1.01
TM9X120D20MP11	FC/MC62D	0.97	0.95	1.01
TM9X120D20MP11	FC64D	1.01	0.98	1.00
TM9X120D20MP11	UC48D	0.99	0.95	1.02
TM9X120D20MP11	UC60D	0.97	0.95	1.02

COOLING PERFORMANCE DATA - HIGH CFM 2-STAGE OPERATION																
OUTDOOR UNIT MODEL NO.		HL8B048F4C														
INDOOR COIL MODEL NO.		FC/MC62D + MV20D														
AIR TEMP. ENTERING OUTDOOR UNIT (°F)	ID CFM	1550					1650					1750				
	ID DB (°F)	80	80	75	80	80	80	80	75	80	80	80	80	75	80	80
	ID WB (°F)	57	62	62	67	72	57	62	62	67	72	57	62	62	67	72
65	T.C.	47.9	50.0	49.1	54.0	58.5	49.5	49.9	49.7	54.3	59.0	51.0	49.9	50.3	54.7	59.4
	S.C.	46.5	43.1	36.3	36.8	28.5	47.0	44.1	37.2	37.3	29.0	47.5	45.1	38.0	37.8	29.4
	KW	2.56	2.57	2.60	2.62	2.65	2.63	2.64	2.66	2.68	2.71	2.71	2.72	2.72	2.75	2.78
75	T.C.	46.3	47.8	46.9	51.3	55.7	47.3	47.8	47.2	51.6	56.2	48.4	47.9	47.5	51.8	56.6
	S.C.	44.8	42.3	35.4	35.7	27.6	45.2	43.2	36.2	36.4	28.2	45.7	44.1	37.0	37.0	28.7
	KW	2.89	2.90	2.93	2.95	2.98	2.96	2.97	2.98	3.01	3.04	3.04	3.05	3.05	3.09	3.11
85	T.C.	44.6	45.6	44.7	48.5	53.0	45.2	45.7	44.7	48.8	53.4	45.8	45.8	44.7	49.0	53.8
	S.C.	43.0	41.5	34.5	34.6	26.6	43.4	42.3	35.3	35.4	27.3	43.8	43.1	36.0	36.2	28.0
	KW	3.22	3.23	3.26	3.28	3.31	3.29	3.30	3.31	3.35	3.36	3.37	3.38	3.38	3.42	3.43
95	T.C.	43.0	43.4	42.5	45.8	50.3	43.1	43.6	42.2	46.0	50.6	43.2	43.8	41.9	46.2	51.0
	S.C.	41.2	40.6	33.7	33.6	25.6	41.6	41.4	34.3	34.5	26.5	42.0	42.1	34.9	35.4	27.4
	KW	3.55	3.55	3.58	3.61	3.63	3.62	3.63	3.64	3.68	3.69	3.69	3.70	3.70	3.75	3.75
105	T.C.	40.6	40.7	39.6	42.9	46.8	40.8	41.1	39.5	42.8	47.3	40.9	41.5	39.4	42.8	47.8
	S.C.	38.9	38.6	32.4	32.3	24.6	39.3	39.2	33.2	33.3	25.5	39.7	39.8	33.9	34.1	26.3
	KW	4.04	4.03	4.05	4.09	4.11	4.11	4.11	4.11	4.15	4.16	4.17	4.18	4.18	4.22	4.22
115	T.C.	38.3	38.0	36.9	40.0	43.5	38.5	38.6	36.9	39.8	44.2	38.7	39.2	36.9	39.5	44.8
	S.C.	36.6	36.6	31.2	31.2	23.7	37.0	37.1	32.1	32.1	24.5	37.4	37.5	32.9	32.9	25.4
	KW	4.52	4.50	4.51	4.55	4.57	4.58	4.57	4.57	4.61	4.62	4.64	4.65	4.64	4.67	4.68
125	T.C.	36.1	35.4	34.1	37.1	40.1	36.3	36.2	34.3	36.7	41.0	36.4	36.9	34.5	36.2	41.8
	S.C.	34.3	34.6	30.0	30.0	22.7	34.7	34.9	31.0	30.9	23.6	35.1	35.2	31.9	31.7	24.4
	KW	5.00	4.97	4.97	5.01	5.03	5.05	5.04	5.03	5.06	5.08	5.11	5.12	5.10	5.13	5.13

NOTE: ALL CAPACITIES INCLUDE INDOOR FAN HEAT. KW VALUES ARE FOR THE SYSTEM (OUTDOOR + INDOOR).

Multipliers for determining the performance with other indoor sections.

NOTE: For dry bulb temperatures different than those listed (between 73-87 °F), sensible capacity increases by 1060 BTUH per 1000 CFM per degree above the listed temperature and decreases by 1060 BTUH per 1000 CFM per degree below the listed temperature.

HIGH CFM

Air Handler	Coil	T.C.	S.C.	KW
-	FC/MC62	0.98	0.96	1.06
AHE60D	-	0.99	0.97	0.99
AHV48D	-	0.99	0.95	1.03
AHV60D	-	0.99	0.97	1.03
MV16C	FC/MC48C	0.99	0.96	1.03
MV16C	FC60C	0.99	0.96	1.03
MV20D	FC/MC48D	0.99	0.97	1.01
MV20D	FC/MC60D	0.99	0.96	1.03
MV20D	FC/MC62D	1.00	1.00	1.00
MV20D	FC64D	1.02	1.02	1.02
MX16CN21	FC/MC48C	0.98	0.96	1.02
MX16CN21	FC60C	0.99	0.96	1.03

Furnace	Coil	T.C.	S.C.	KW
T*(8,L)V*C20	FC/MC/PC60D	0.99	0.96	1.05
T*(8,L)V*C20	FC/MC62D	0.99	0.98	1.03
T*(8,L)V*C20	FC/PC60C	0.99	0.96	1.05
T*(8,L)V*C20	FC64D	1.02	1.01	1.04
T*(8,L)V*C20	UC48C	0.99	0.96	1.08
T*(8,L)V*C20	UC60C	0.98	0.95	1.02
T*9V*C16	FC/MC/PC48C	0.98	0.96	1.06
T*9V*C16	FC/MC/PC48D	0.98	0.96	1.06
T*9V*C16	FC/MC/PC60D	0.98	0.96	1.06
T*9V*C16	FC/MC62D	0.99	0.97	1.05
T*9V*C16	FC/PC60C	0.98	0.96	1.06
T*9V*C16	FC64D	1.01	1.01	1.05
T*9V*C16	UC48C	0.97	0.93	1.05
T*9V*C16	UC60C	0.97	0.92	1.05
T*9V*C20	FC/MC/PC48C	0.98	0.96	1.06
T*9V*C20	FC/MC/PC48D	0.98	0.96	1.06
T*9V*C20	FC/MC/PC60D	0.98	0.96	1.06
T*9V*C20	FC/MC62D	0.99	0.98	1.08
T*9V*C20	FC/PC60C	0.98	0.96	1.06
T*9V*C20	FC64D	1.01	1.01	1.08
T*9V*C20	UC48C	0.99	0.96	1.08
T*9V*C20	UC60C	0.98	0.96	1.06
T*9V*D20	FC/MC/PC48D	0.98	0.96	1.06

Continued on next page.

Furnace	Coil	T.C.	S.C.	KW
T*9V*D20	FC/MC/PC60D	0.98	0.96	1.04
T*9V*D20	FC/MC62D	0.99	0.98	1.05
T*9V*D20	FC64D	1.01	1.01	1.05
T*9V*D20	UC48D	0.99	0.96	1.08
T*9V*D20	UC60D	0.98	0.94	1.06
TM8X080C16MP11	FC/MC/PC48C	0.97	0.93	1.05
TM8X080C16MP11	FC/MC/PC48D	0.98	0.96	1.04
TM8X080C16MP11	FC/MC/PC60D	0.99	0.96	1.05
TM8X080C16MP11	FC/MC62D	0.99	0.96	1.05
TM8X080C16MP11	FC/PC60C	0.97	0.93	1.05
TM8X080C16MP11	FC64D	1.01	1.01	1.05
TM8X080C16MP11	UC48C	0.98	0.93	1.06
TM8X080C16MP11	UC48D	0.98	0.93	1.06
TM8X080C16MP11	UC60C	0.97	0.92	1.05
TM8X080C16MP11	UC60D	0.97	0.92	1.05
TM8X100C16MP11	FC/MC/PC48C	0.97	0.93	1.05
TM8X100C16MP11	FC/MC/PC48D	0.98	0.96	1.04
TM8X100C16MP11	FC/MC/PC60D	0.99	0.96	1.05
TM8X100C16MP11	FC/MC62D	0.99	0.96	1.05
TM8X100C16MP11	FC/PC60C	0.97	0.93	1.05
TM8X100C16MP11	FC64D	1.01	1.01	1.05
TM8X100C16MP11	UC48C	0.98	0.93	1.06
TM8X100C16MP11	UC48D	0.98	0.93	1.06
TM8X100C16MP11	UC60C	0.97	0.92	1.05
TM8X100C16MP11	UC60D	0.97	0.92	1.05
TM8X100C20MP11	FC/MC/PC48C	0.98	0.94	1.04
TM8X100C20MP11	FC/MC/PC48D	0.98	0.94	1.04
TM8X100C20MP11	FC/MC/PC60D	0.98	0.94	1.04
TM8X100C20MP11	FC/MC62D	0.99	0.96	1.05
TM8X100C20MP11	FC/PC60C	0.99	0.96	1.05
TM8X100C20MP11	UC48C	0.98	0.94	1.04
TM8X100C20MP11	UC48D	0.98	0.95	1.04
TM8X100C20MP11	UC60C	0.97	0.93	1.03
TM8X100C20MP11	UC60D	0.98	0.94	1.04
TM8X120C20MP11	FC/MC/PC48C	0.98	0.94	1.04
TM8X120C20MP11	FC/MC/PC48D	0.98	0.94	1.04
TM8X120C20MP11	FC/MC/PC60D	0.98	0.94	1.04
TM8X120C20MP11	FC/MC62D	0.99	0.96	1.05
TM8X120C20MP11	FC/PC60C	0.99	0.96	1.05
TM8X120C20MP11	UC48C	0.98	0.94	1.04
TM8X120C20MP11	UC48D	0.98	0.95	1.04
TM8X120C20MP11	UC60C	0.97	0.93	1.03
TM8X120C20MP11	UC60D	0.98	0.94	1.04
TMLX080C16MP11	FC/MC/PC48C	0.97	0.93	1.05
TMLX080C16MP11	FC/MC/PC48D	0.98	0.96	1.04
TMLX080C16MP11	FC/MC/PC60D	0.99	0.96	1.05
TMLX080C16MP11	FC/MC62D	0.99	0.96	1.05
TMLX080C16MP11	FC/PC60C	0.97	0.93	1.05
TMLX080C16MP11	FC64D	1.01	1.01	1.05
TMLX080C16MP11	UC48C	0.98	0.93	1.06
TMLX080C16MP11	UC48D	0.98	0.93	1.06
TMLX080C16MP11	UC60C	0.97	0.92	1.05
TMLX080C16MP11	UC60D	0.97	0.92	1.05
TMLX100C16MP11	FC/MC/PC48C	0.97	0.93	1.05
TMLX100C16MP11	FC/MC/PC48D	0.98	0.96	1.04
TMLX100C16MP11	FC/MC/PC60D	0.99	0.96	1.05

Furnace	Coil	T.C.	S.C.	KW
TMLX100C16MP11	FC/MC62D	0.99	0.96	1.05
TMLX100C16MP11	FC/PC60C	0.97	0.93	1.05
TMLX100C16MP11	FC64D	1.01	1.01	1.05
TMLX100C16MP11	UC48C	0.98	0.93	1.06
TMLX100C16MP11	UC48D	0.98	0.93	1.06
TMLX100C16MP11	UC60C	0.97	0.92	1.05
TMLX100C16MP11	UC60D	0.97	0.92	1.05
TMLX100C20MP11	FC/MC/PC48C	0.98	0.94	1.04
TMLX100C20MP11	FC/MC/PC48D	0.98	0.94	1.04
TMLX100C20MP11	FC/MC/PC60D	0.98	0.94	1.04
TMLX100C20MP11	FC/MC62D	0.99	0.96	1.05
TMLX100C20MP11	FC/PC60C	0.99	0.96	1.05
TMLX100C20MP11	UC48C	0.98	0.94	1.04
TMLX100C20MP11	UC48D	0.98	0.95	1.04
TMLX100C20MP11	UC60C	0.97	0.93	1.03
TMLX100C20MP11	UC60D	0.98	0.94	1.04
TMLX120C20MP11	FC/MC/PC48C	0.98	0.94	1.04
TMLX120C20MP11	FC/MC/PC48D	0.98	0.94	1.04
TMLX120C20MP11	FC/MC/PC60D	0.98	0.94	1.04
TMLX120C20MP11	FC/MC62D	0.99	0.96	1.05
TMLX120C20MP11	FC/PC60C	0.99	0.96	1.05
TMLX120C20MP11	UC48C	0.98	0.94	1.04
TMLX120C20MP11	UC48D	0.98	0.95	1.04
TMLX120C20MP11	UC60C	0.97	0.93	1.03
TMLX120C20MP11	UC60D	0.98	0.94	1.04
TM9E100C20MP11	FC/MC/PC48C	0.97	0.92	1.05
TM9E100C20MP11	FC/MC/PC48D	0.97	0.93	1.05
TM9E100C20MP11	FC/MC/PC60D	0.97	0.93	1.05
TM9E100C20MP11	FC/MC62D	0.99	0.96	1.05
TM9E100C20MP11	FC64D	1.00	0.98	1.04
TM9E100C20MP11	UC48C	0.97	0.92	1.05
TM9E100C20MP11	UC48D	0.98	0.93	1.06
TM9E100C20MP11	UC60D	0.97	0.92	1.05
TM9E120D20MP11	FC/MC/PC48D	0.97	0.93	1.05
TM9E120D20MP11	FC/MC/PC60D	0.98	0.93	1.04
TM9E120D20MP11	FC/MC62D	0.99	0.96	1.05
TM9E120D20MP11	FC64D	1.00	0.98	1.04
TM9E120D20MP11	UC48D	0.98	0.93	1.04
TM9E120D20MP11	UC60D	0.97	0.92	1.03
TM9X100C20MP11	FC/MC/PC48C	0.97	0.92	1.05
TM9X100C20MP11	FC/MC/PC48D	0.97	0.93	1.05
TM9X100C20MP11	FC/MC/PC60D	0.97	0.93	1.05
TM9X100C20MP11	FC/MC62D	0.99	0.96	1.05
TM9X100C20MP11	FC64D	1.00	0.98	1.04
TM9X100C20MP11	UC48C	0.97	0.92	1.05
TM9X100C20MP11	UC48D	0.98	0.93	1.06
TM9X100C20MP11	UC60D	0.97	0.92	1.05
TM9X120D20MP11	FC/MC/PC48D	0.97	0.93	1.05
TM9X120D20MP11	FC/MC/PC60D	0.98	0.93	1.04
TM9X120D20MP11	FC/MC62D	0.99	0.96	1.05
TM9X120D20MP11	FC64D	1.00	0.98	1.04
TM9X120D20MP11	UC48D	0.98	0.93	1.04
TM9X120D20MP11	UC60D	0.97	0.92	1.03

COOLING PERFORMANCE DATA - LOW CFM 1-STAGE OPERATION																
OUTDOOR UNIT MODEL NO.		HL8B060F4C														
INDOOR COIL MODEL NO.		FC/MC62D + MV20D														
AIR TEMP. ENTERING OUTDOOR UNIT (°F)	ID CFM	1125					1175					1225				
	ID DB (°F)	80	80	75	80	80	80	80	75	80	80	80	80	75	80	80
	ID WB (°F)	57	62	62	67	72	57	62	62	67	72	57	62	62	67	72
65	T.C.	37.7	42.7	43.0	46.8	51.0	38.2	43.4	43.2	47.0	51.5	38.7	44.1	43.4	47.3	52.1
	S.C.	37.5	35.6	30.7	30.1	24.7	38.0	36.2	31.3	30.6	25.0	38.5	36.8	31.8	31.0	25.3
	K.W.	2.08	2.05	2.05	2.03	2.04	2.09	2.07	2.06	2.05	2.05	2.10	2.08	2.08	2.07	2.07
75	T.C.	35.9	40.7	40.8	44.7	48.7	36.3	41.4	41.0	45.1	49.2	36.7	42.0	41.3	45.4	49.6
	S.C.	35.8	34.8	29.7	29.3	23.8	36.2	35.5	30.3	29.8	24.1	36.6	36.2	30.8	30.3	24.4
	K.W.	2.43	2.41	2.41	2.39	2.40	2.44	2.43	2.43	2.41	2.42	2.45	2.44	2.44	2.43	2.43
85	T.C.	34.2	38.7	38.6	42.7	46.4	34.5	39.3	38.9	43.1	46.8	34.8	39.9	39.2	43.4	47.1
	S.C.	34.0	33.9	28.7	28.6	22.8	34.3	34.7	29.3	29.1	23.1	34.7	35.6	29.8	29.6	23.4
	K.W.	2.78	2.77	2.77	2.76	2.76	2.79	2.78	2.79	2.77	2.78	2.81	2.80	2.80	2.79	2.79
95	T.C.	32.4	36.7	36.3	40.7	44.1	32.6	37.3	36.7	41.1	44.4	32.9	37.9	37.1	41.5	44.6
	S.C.	32.2	33.0	27.7	27.8	21.9	32.5	34.0	28.3	28.4	22.2	32.7	35.0	28.8	28.9	22.5
	K.W.	3.13	3.12	3.13	3.12	3.12	3.15	3.14	3.15	3.14	3.14	3.16	3.16	3.16	3.15	3.15
105	T.C.	29.8	34.0	33.7	37.4	41.5	30.0	34.4	34.1	37.9	41.8	30.1	34.8	34.6	38.5	42.1
	S.C.	29.7	31.4	26.2	26.3	20.7	29.8	32.1	26.7	27.0	21.0	30.0	32.8	27.2	27.7	21.3
	K.W.	3.60	3.60	3.60	3.58	3.59	3.61	3.62	3.62	3.60	3.60	3.63	3.64	3.64	3.63	3.62
115	T.C.	27.3	31.2	31.2	34.1	38.9	27.3	31.5	31.6	34.8	39.2	27.4	31.7	32.1	35.5	39.6
	S.C.	27.2	29.8	24.7	24.8	19.6	27.2	30.3	25.1	25.7	19.9	27.3	30.7	25.6	26.5	20.2
	K.W.	4.06	4.06	4.05	4.03	4.04	4.07	4.08	4.08	4.06	4.06	4.08	4.10	4.10	4.09	4.07
125	T.C.	24.8	28.5	28.6	30.9	36.3	24.7	28.6	29.1	31.7	36.7	24.7	28.7	29.5	32.6	37.0
	S.C.	24.7	28.2	23.2	23.3	18.5	24.6	28.4	23.6	24.3	18.8	24.6	28.6	24.0	25.4	19.1
	K.W.	4.52	4.52	4.51	4.48	4.50	4.52	4.54	4.53	4.51	4.51	4.53	4.56	4.56	4.55	4.53

NOTE: ALL CAPACITIES INCLUDE INDOOR FAN HEAT. KW VALUES ARE FOR THE SYSTEM (OUTDOOR + INDOOR).

Multipliers for determining the performance with other indoor sections.

NOTE: For dry bulb temperatures different than those listed (between 73-87 °F), sensible capacity increases by 1060 BTUH per 1000 CFM per degree above the listed temperature and decreases by 1060 BTUH per 1000 CFM per degree below the listed temperature.

LOW CFM

Air Handler	Coil	T.C.	S.C.	KW
-	FC/MC62	1.00	1.03	1.16
AHE60D	-	0.99	0.98	1.01
AHV60D	-	0.98	0.96	1.00
MV20D	FC/MC60D	1.00	0.97	1.02
MV20D	FC/MC62D	1.00	1.00	1.00
MV20D	FC64D	1.03	1.02	1.01

Continued on next page.

Furnace	Coil	T.C.	S.C.	KW
T*(8,L)V*C16	FC/PC60C	0.97	0.92	1.03
T*(8,L)V*C20	FC/MC/PC60D	0.98	0.93	1.03
T*(8,L)V*C20	FC/MC62D	0.96	0.92	1.03
T*(8,L)V*C20	FC/PC60C	0.98	0.93	1.03
T*(8,L)V*C20	FC64D	1.01	0.98	1.02
T*(8,L)V*C20	UC60C	0.95	0.91	1.01
T*9V*C20	FC/MC/PC60D	0.97	0.93	1.03
T*9V*C20	FC/MC62D	0.97	0.93	1.03
T*9V*C20	FC/PC60C	0.97	0.93	1.03
T*9V*C20	FC64D	1.00	0.97	1.02
T*9V*C20	UC60C	0.96	0.92	1.03
T*9V*D20	FC/MC/PC60D	0.98	0.94	1.04
T*9V*D20	FC/MC62D	0.97	0.95	1.03
T*9V*D20	FC64D	1.01	0.99	1.02
T*9V*D20	UC60D	0.96	0.93	1.03
TM8X080C16MP11	FC/MC/PC60D	0.98	0.93	1.01
TM8X080C16MP11	FC/MC62D	0.97	0.93	1.00
TM8X080C16MP11	FC/PC60C	0.97	0.92	1.02
TM8X080C16MP11	FC64D	1.01	0.97	1.00
TM8X080C16MP11	UC60C	0.96	0.91	1.02
TM8X080C16MP11	UC60D	0.96	0.91	1.02
TM8X100C16MP11	FC/MC/PC60D	0.98	0.93	1.01
TM8X100C16MP11	FC/MC62D	0.97	0.93	1.00
TM8X100C16MP11	FC/PC60C	0.97	0.92	1.02
TM8X100C16MP11	FC64D	1.01	0.97	1.00
TM8X100C16MP11	UC60C	0.96	0.91	1.02
TM8X100C16MP11	UC60D	0.96	0.91	1.02
TM8X100C20MP11	FC/MC/PC60D	0.99	0.95	1.01
TM8X100C20MP11	FC/MC62D	0.98	0.96	1.01
TM8X100C20MP11	FC/PC60C	0.98	0.95	1.01
TM8X100C20MP11	UC60C	0.97	0.93	1.03
TM8X100C20MP11	UC60D	0.97	0.94	1.02
TM8X120C20MP11	FC/MC/PC60D	0.99	0.95	1.01
TM8X120C20MP11	FC/MC62D	0.98	0.96	1.01
TM8X120C20MP11	FC/PC60C	0.98	0.95	1.01
TM8X120C20MP11	UC60C	0.97	0.93	1.03
TM8X120C20MP11	UC60D	0.97	0.94	1.02
TMLX080C16MP11	FC/MC/PC60D	0.98	0.93	1.01
TMLX080C16MP11	FC/MC62D	0.97	0.93	1.00
TMLX080C16MP11	FC/PC60C	0.97	0.92	1.02
TMLX080C16MP11	FC64D	1.01	0.97	1.00
TMLX080C16MP11	UC60C	0.96	0.91	1.02
TMLX080C16MP11	UC60D	0.96	0.91	1.02
TMLX100C16MP11	FC/MC/PC60D	0.98	0.93	1.01
TMLX100C16MP11	FC/MC62D	0.97	0.93	1.00

Furnace	Coil	T.C.	S.C.	KW
TMLX100C16MP11	FC/PC60C	0.97	0.92	1.02
TMLX100C16MP11	FC64D	1.01	0.97	1.00
TMLX100C16MP11	UC60C	0.96	0.91	1.02
TMLX100C16MP11	UC60D	0.96	0.91	1.02
TMLX100C20MP11	FC/MC/PC60D	0.99	0.95	1.01
TMLX100C20MP11	FC/MC62D	0.98	0.96	1.01
TMLX100C20MP11	FC/PC60C	0.98	0.95	1.01
TMLX100C20MP11	UC60C	0.97	0.93	1.03
TMLX100C20MP11	UC60D	0.97	0.94	1.02
TMLX120C20MP11	FC/MC/PC60D	0.99	0.95	1.01
TMLX120C20MP11	FC/MC62D	0.98	0.96	1.01
TMLX120C20MP11	FC/PC60C	0.98	0.95	1.01
TMLX120C20MP11	UC60C	0.97	0.93	1.03
TMLX120C20MP11	UC60D	0.97	0.94	1.02
TM9E100C20MP11	FC/MC/PC60D	0.96	0.90	1.00
TM9E100C20MP11	FC/MC62D	0.96	0.91	1.00
TM9E100C20MP11	FC64D	0.99	0.95	0.99
TM9E100C20MP11	UC60D	0.94	0.89	1.01
TM9E120D20MP11	FC/MC/PC60D	0.96	0.91	0.99
TM9E120D20MP11	FC/MC62D	0.96	0.91	1.00
TM9E120D20MP11	FC64D	0.99	0.94	1.00
TM9E120D20MP11	UC60D	0.96	0.91	1.02
TM9X100C20MP11	FC/MC/PC60D	0.96	0.90	1.00
TM9X100C20MP11	FC/MC62D	0.96	0.91	1.00
TM9X100C20MP11	FC64D	0.99	0.95	0.99
TM9X100C20MP11	UC60D	0.94	0.89	1.01
TM9X120D20MP11	FC/MC/PC60D	0.96	0.91	0.99
TM9X120D20MP11	FC/MC62D	0.96	0.91	1.00
TM9X120D20MP11	FC64D	0.99	0.94	1.00
TM9X120D20MP11	UC60D	0.96	0.91	1.02
Y*LC*C16	FC/PC60C	0.97	0.92	1.03
Y*LC*C20	FC/MC/PC60D	0.98	0.93	1.03
Y*LC*C20	FC/MC62D	0.96	0.92	1.03
Y*LC*C20	FC/PC60C	0.98	0.93	1.03
Y*LC*C20	FC64D	1.01	0.98	1.02
Y*LC*C20	UC60C	0.95	0.91	1.01
Y*9C*C20	FC/MC/PC60D	0.97	0.93	1.03
Y*9C*C20	FC/MC62D	0.97	0.93	1.03
Y*9C*C20	FC/PC60C	0.97	0.93	1.03
Y*9C*C20	FC64D	1.00	0.97	1.02
Y*9C*C20	UC60C	0.96	0.92	1.03
Y*9C*D20	FC/MC/PC60D	0.98	0.94	1.04
Y*9C*D20	FC/MC62D	0.97	0.95	1.03
Y*9C*D20	FC64D	1.01	0.99	1.02
Y*9C*D20	UC60D	0.96	0.93	1.03

COOLING PERFORMANCE DATA - HIGH CFM 2-STAGE OPERATION																
OUTDOOR UNIT MODEL NO.		HL8B060F4C														
INDOOR COIL MODEL NO.		FC/MC62D + MV20D														
AIR TEMP. ENTERING OUTDOOR UNIT (°F)	ID CFM	1750					1850					1950				
	ID DB (°F)	80	80	75	80	80	80	80	75	80	80	80	80	75	80	80
	ID WB (°F)	57	62	62	67	72	57	62	62	67	72	57	62	62	67	72
65	T.C.	54.7	60.1	58.8	64.1	66.9	55.5	61.1	59.5	64.7	67.8	56.3	62.1	60.1	65.4	68.5
	S.C.	54.2	50.7	43.1	42.4	33.8	55.1	52.1	44.2	43.4	34.5	55.9	53.5	45.3	44.3	35.1
	K.W.	3.37	3.42	3.43	3.49	3.62	3.46	3.51	3.50	3.57	3.70	3.55	3.60	3.59	3.66	3.79
75	T.C.	52.7	57.7	56.6	61.5	63.5	53.4	58.6	57.2	62.2	64.0	54.0	59.5	57.8	62.8	64.4
	S.C.	52.2	49.9	42.1	41.5	32.9	52.9	51.2	43.2	42.4	33.4	53.6	52.5	44.2	43.3	33.9
	K.W.	3.81	3.85	3.85	3.91	4.03	3.89	3.93	3.92	3.99	4.11	3.99	4.02	4.01	4.08	4.20
85	T.C.	50.6	55.3	54.4	58.9	60.1	51.2	56.1	54.9	59.6	60.2	51.7	56.9	55.4	60.2	60.3
	S.C.	50.2	49.1	41.1	40.5	31.9	50.8	50.3	42.1	41.4	32.3	51.3	51.5	43.1	42.3	32.7
	K.W.	4.24	4.27	4.26	4.33	4.44	4.33	4.35	4.34	4.41	4.52	4.42	4.44	4.43	4.50	4.61
95	T.C.	48.6	53.0	52.3	56.3	56.6	49.0	53.6	52.6	57.0	56.4	49.4	54.2	53.0	57.7	56.2
	S.C.	48.2	48.3	40.1	39.6	31.0	48.6	49.4	41.1	40.5	31.2	49.0	50.5	42.0	41.3	31.5
	K.W.	4.68	4.69	4.68	4.75	4.86	4.76	4.77	4.76	4.83	4.93	4.85	4.85	4.85	4.92	5.02
105	T.C.	45.8	49.9	49.2	53.1	52.6	45.9	50.4	49.6	53.7	52.3	46.0	50.8	49.9	54.3	52.0
	S.C.	45.4	46.6	38.6	38.3	29.5	45.5	47.4	39.5	39.2	29.9	45.6	48.2	40.3	40.0	30.2
	K.W.	5.29	5.29	5.28	5.35	5.45	5.37	5.36	5.36	5.42	5.52	5.46	5.45	5.45	5.51	5.61
115	T.C.	43.1	47.0	46.2	49.9	48.7	42.9	47.2	46.6	50.5	48.3	42.7	47.4	47.0	50.9	47.8
	S.C.	42.7	45.0	37.1	37.0	28.1	42.5	45.5	37.9	37.9	28.5	42.4	46.0	38.7	38.7	28.9
	K.W.	5.87	5.86	5.85	5.93	6.02	5.95	5.94	5.93	6.00	6.10	6.04	6.03	6.02	6.08	6.18
125	T.C.	40.3	44.1	43.2	46.8	44.9	39.9	44.1	43.6	47.2	44.3	39.4	44.1	44.0	47.6	43.7
	S.C.	40.0	43.4	35.6	35.8	26.7	39.6	43.6	36.3	36.6	27.2	39.1	43.7	37.0	37.4	27.7
	K.W.	6.46	6.44	6.43	6.51	6.60	6.54	6.52	6.51	6.58	6.68	6.63	6.61	6.60	6.66	6.76

NOTE: ALL CAPACITIES INCLUDE INDOOR FAN HEAT. KW VALUES ARE FOR THE SYSTEM (OUTDOOR + INDOOR).

Multipliers for determining the performance with other indoor sections.

NOTE: For dry bulb temperatures different than those listed (between 73-87 °F), sensible capacity increases by 1060 BTUH per 1000 CFM per degree above the listed temperature and decreases by 1060 BTUH per 1000 CFM per degree below the listed temperature.

HIGH CFM

Air Handler	Coil	T.C.	S.C.	KW
–	FC/MC62	0.98	0.98	1.05
AHE60D	–	1.00	1.00	1.02
AHV60D	–	0.98	0.94	1.00
MV20D	FC/MC60D	0.99	0.96	1.01
MV20D	FC/MC62D	1.00	1.00	1.00
MV20D	FC64D	1.02	1.02	1.04

Continued on next page.

Furnace	Coil	T.C.	S.C.	KW
T*(8,L)V*C16	FC/PC60C	0.96	0.90	1.03
T*(8,L)V*C20	FC/MC/PC60D	0.96	0.91	1.01
T*(8,L)V*C20	FC/MC62D	0.97	0.93	1.02
T*(8,L)V*C20	FC/PC60C	0.96	0.91	1.01
T*(8,L)V*C20	FC64D	1.02	1.01	1.06
T*(8,L)V*C20	UC60C	0.96	0.91	1.01
T*9V*C20	FC/MC/PC60D	0.97	0.92	1.02
T*9V*C20	FC/MC62D	0.98	0.94	1.03
T*9V*C20	FC/PC60C	0.97	0.92	1.02
T*9V*C20	FC64D	1.00	0.96	1.04
T*9V*C20	UC60C	0.96	0.91	1.03
T*9V*D20	FC/MC/PC60D	0.96	0.91	1.03
T*9V*D20	FC/MC62D	0.97	0.94	1.02
T*9V*D20	FC64D	1.00	0.96	1.02
T*9V*D20	UC60D	0.96	0.91	1.03
TM8X080C16MP11	FC/MC/PC60D	0.96	0.89	1.03
TM8X080C16MP11	FC/MC62D	0.96	0.92	1.01
TM8X080C16MP11	FC/PC60C	0.96	0.88	1.02
TM8X080C16MP11	FC64D	0.99	0.94	1.01
TM8X080C16MP11	UC60C	0.95	0.88	1.01
TM8X080C16MP11	UC60D	0.95	0.88	1.01
TM8X100C16MP11	FC/MC/PC60D	0.96	0.89	1.03
TM8X100C16MP11	FC/MC62D	0.96	0.92	1.01
TM8X100C16MP11	FC/PC60C	0.96	0.88	1.02
TM8X100C16MP11	FC64D	0.99	0.94	1.01
TM8X100C16MP11	UC60C	0.95	0.88	1.01
TM8X100C16MP11	UC60D	0.95	0.88	1.01
TM8X100C20MP11	FC/MC/PC60D	0.96	0.90	1.01
TM8X100C20MP11	FC/MC62D	0.97	0.93	1.02
TM8X100C20MP11	FC/PC60C	0.96	0.90	1.01
TM8X100C20MP11	UC60C	0.96	0.89	1.02
TM8X100C20MP11	UC60D	0.96	0.90	1.00
TM8X120C20MP11	FC/MC/PC60D	0.96	0.90	1.01
TM8X120C20MP11	FC/MC62D	0.97	0.93	1.02
TM8X120C20MP11	FC/PC60C	0.96	0.90	1.01
TM8X120C20MP11	UC60C	0.96	0.89	1.02
TM8X120C20MP11	UC60D	0.96	0.90	1.00
TMLX080C16MP11	FC/MC/PC60D	0.96	0.89	1.03

Furnace	Coil	T.C.	S.C.	KW
TMLX080C16MP11	FC/MC62D	0.96	0.92	1.01
TMLX080C16MP11	FC/PC60C	0.96	0.88	1.02
TMLX080C16MP11	FC64D	0.99	0.94	1.01
TMLX080C16MP11	UC60C	0.95	0.88	1.01
TMLX080C16MP11	UC60D	0.95	0.88	1.01
TMLX100C16MP11	FC/MC/PC60D	0.96	0.89	1.03
TMLX100C16MP11	FC/MC62D	0.96	0.92	1.01
TMLX100C16MP11	FC/PC60C	0.96	0.88	1.02
TMLX100C16MP11	FC64D	0.99	0.94	1.01
TMLX100C16MP11	UC60C	0.95	0.88	1.01
TMLX100C16MP11	UC60D	0.95	0.88	1.01
TMLX100C20MP11	FC/MC/PC60D	0.96	0.90	1.01
TMLX100C20MP11	FC/MC62D	0.97	0.93	1.02
TMLX100C20MP11	FC/PC60C	0.96	0.90	1.01
TMLX100C20MP11	UC60C	0.96	0.89	1.02
TMLX100C20MP11	UC60D	0.96	0.90	1.00
TMLX120C20MP11	FC/MC/PC60D	0.96	0.90	1.01
TMLX120C20MP11	FC/MC62D	0.97	0.93	1.02
TMLX120C20MP11	FC/PC60C	0.96	0.90	1.01
TMLX120C20MP11	UC60C	0.96	0.89	1.02
TMLX120C20MP11	UC60D	0.96	0.90	1.00
TM9E100C20MP11	FC/MC/PC60D	0.96	0.88	1.02
TM9E100C20MP11	FC/MC62D	0.96	0.92	1.01
TM9E100C20MP11	FC64D	0.99	0.94	1.01
TM9E100C20MP11	UC60D	0.95	0.88	1.01
TM9E120D20MP11	FC/MC/PC60D	0.96	0.89	1.01
TM9E120D20MP11	FC/MC62D	0.97	0.92	1.02
TM9E120D20MP11	FC64D	0.99	0.93	1.01
TM9E120D20MP11	UC60D	0.96	0.88	1.02
TM9X100C20MP11	FC/MC/PC60D	0.96	0.88	1.02
TM9X100C20MP11	FC/MC62D	0.96	0.92	1.01
TM9X100C20MP11	FC64D	0.99	0.94	1.01
TM9X100C20MP11	UC60D	0.95	0.88	1.01
TM9X120D20MP11	FC/MC/PC60D	0.96	0.89	1.01
TM9X120D20MP11	FC/MC62D	0.97	0.92	1.02
TM9X120D20MP11	FC64D	0.99	0.93	1.01
TM9X120D20MP11	UC60D	0.96	0.88	1.02

HEATING PERFORMANCE DATA - LOW CFM 1-STAGE OPERATION

CONDENSING UNIT MODEL NO.		HL8B024F4C								
EVAPORATOR COIL MODEL NO.		FC/MC48D + MV12D								
AIR TEMP. ENTERING OUTDOOR UNIT (°F)	AIR TEMP. ENTERING INDOOR COIL (°F)	ID CFM								
		550			600			650		
		MBH	COP	KW	MBH	COP	KW	MBH	COP	KW
60	60	21.60	4.07	1.55	22.10	4.66	1.39	22.70	5.39	1.24
	70	21.50	3.51	1.80	22.00	4.00	1.61	22.40	4.63	1.42
	80	21.50	3.08	2.04	21.80	3.50	1.82	22.20	4.04	1.61
47	60	18.80	3.64	1.51	19.20	4.05	1.39	19.60	4.54	1.26
	70	18.70	3.14	1.75	19.00	3.50	1.59	19.30	3.94	1.44
	80	18.70	2.76	1.98	18.80	3.07	1.79	19.00	3.46	1.61
40	60	17.20	3.39	1.49	17.50	3.71	1.38	17.70	4.09	1.27
	70	17.10	2.94	1.70	17.30	3.23	1.57	17.50	3.56	1.44
	80	17.00	2.59	1.92	17.10	2.84	1.76	17.30	3.14	1.61
30	60	–	–	–	–	–	–	–	–	–
	70	–	–	–	–	–	–	–	–	–
	80	–	–	–	–	–	–	–	–	–
17	60	–	–	–	–	–	–	–	–	–
	70	–	–	–	–	–	–	–	–	–
	80	–	–	–	–	–	–	–	–	–
10	60	–	–	–	–	–	–	–	–	–
	70	–	–	–	–	–	–	–	–	–
	80	–	–	–	–	–	–	–	–	–

NOTE: ALL CAPACITIES ARE NET, WITH INDOOR FAN HEAT ALREADY DEDUCTED. KW VALUES ARE FOR THE SYSTEM (OUTDOOR + INDOOR).

Multipliers for determining the performance with other indoor section.

LOW CFM

Air Handler	Coil	MBH	COP	KW
–	FC/MC/PC48	1.04	0.93	1.12
AHV24B	–	0.96	0.90	1.07
AHV30B	–	0.99	0.91	1.08
AHV36C	–	0.99	0.93	1.07
MV12B	FC/MC43B	1.01	0.99	1.02
MV12D	FC/MC48D	1.00	1.00	1.00
MV12D	FC/MC60D	1.01	1.03	0.98

Furnace	Coil	MBH	COP	KW
T*9V*C20	UC48C	1.03	1.07	0.96
TM8X080C16MP11	FC/MC/PC43C	1.02	1.00	1.02
TM8X080C16MP11	FC/MC/PC48C	1.02	1.01	1.01
TM8X080C16MP11	FC/PC60C	1.02	1.01	1.00
TM8X080C16MP11	UC48C	1.03	1.06	0.97
TM8X080C16MP11	UC60C	1.02	1.01	1.00
TM8X100C16MP11	FC/MC/PC43C	1.02	1.00	1.02
TM8X100C16MP11	FC/MC/PC48C	1.02	1.01	1.01
TM8X100C16MP11	FC/PC60C	1.02	1.01	1.00
TM8X100C16MP11	UC48C	1.03	1.06	0.97
TM8X100C16MP11	UC60C	1.02	1.01	1.00
TMLX080C16MP11	FC/MC/PC43C	1.02	1.00	1.02
TMLX080C16MP11	FC/MC/PC48C	1.02	1.01	1.01
TMLX080C16MP11	FC/PC60C	1.02	1.01	1.00
TMLX080C16MP11	UC48C	1.03	1.06	0.97
TMLX080C16MP11	UC60C	1.02	1.01	1.00
TMLX100C16MP11	FC/MC/PC43C	1.02	1.00	1.02
TMLX100C16MP11	FC/MC/PC48C	1.02	1.01	1.01
TMLX100C16MP11	FC/PC60C	1.02	1.01	1.00
TMLX100C16MP11	UC48C	1.03	1.06	0.97
TMLX100C16MP11	UC60C	1.02	1.01	1.00

Furnace	Coil	MBH	COP	KW
T*(8,L)V*A12	FC/MC/PC37A	1.01	0.98	1.03
T*(8,L)V*B12	FC/MC/PC43B	1.01	0.93	1.09
T*(8,L)V*C16	FC/MC/PC43C	1.02	1.01	1.00
T*9V*A10	FC/MC/PC37A	1.01	0.95	1.06
T*9V*B12	FC/MC/PC43B	1.00	0.96	1.04
T*9V*C16	FC/MC/PC48C	1.01	1.02	0.98
T*9V*C16	FC/PC60C	1.01	1.03	0.98
T*9V*C16	UC48C	1.03	1.07	0.96
T*9V*C16	UC60C	1.01	1.03	0.98
T*9V*C20	FC/MC/PC43C	1.01	1.01	1.00
T*9V*C20	FC/MC/PC48C	1.01	1.02	0.98

HEATING PERFORMANCE DATA - HIGH CFM 2-STAGE OPERATION										
OUTDOOR UNIT MODEL NO.		HL8B024F4C								
INDOOR COIL MODEL NO.		FC/MC48D + MV12D								
AIR TEMP. ENTERING OUTDOOR UNIT (°F)	AIR TEMP. ENTERING INDOOR COIL (°F)	ID CFM								
		800			900			1000		
		MBH	COP	KW	MBH	COP	KW	MBH	COP	KW
60	60	28.7	4.81	1.75	29.2	5.24	1.63	29.6	5.76	1.51
	70	28.1	4.03	2.04	28.5	4.47	1.87	28.9	5.02	1.69
	80	27.4	3.45	2.33	27.7	3.87	2.10	28.1	4.42	1.87
47	60	24.2	4.25	1.67	24.6	4.67	1.54	24.9	5.19	1.41
	70	23.7	3.63	1.91	24.0	4.00	1.76	24.3	4.44	1.61
	80	23.2	3.14	2.16	23.4	3.46	1.98	23.7	3.85	1.80
40	60	21.6	3.96	1.60	22.0	4.34	1.49	22.5	4.81	1.37
	70	21.3	3.44	1.81	21.6	3.75	1.69	21.9	4.11	1.56
	80	21.0	3.03	2.03	21.1	3.27	1.89	21.3	3.57	1.75
30	60	20.7	3.51	1.72	21.0	3.82	1.61	21.3	4.16	1.50
	70	20.3	3.04	1.96	20.5	3.30	1.82	20.8	3.57	1.70
	80	20.0	2.67	2.19	20.1	2.88	2.05	20.2	3.11	1.90
17	60	17.0	3.23	1.54	17.4	3.46	1.47	17.7	3.69	1.41
	70	16.5	2.84	1.70	16.8	3.00	1.64	17.1	3.20	1.57
	80	16.0	2.50	1.87	16.2	2.64	1.80	16.5	2.79	1.73
10	60	15.1	2.85	1.55	15.2	3.04	1.47	15.4	3.25	1.39
	70	14.7	2.60	1.65	14.8	2.75	1.58	15.0	2.94	1.50
	80	14.2	2.37	1.76	14.5	2.51	1.69	14.7	2.67	1.61

NOTE: ALL CAPACITIES ARE NET, WITH INDOOR FAN HEAT ALREADY DEDUCTED. KW VALUES ARE FOR THE SYSTEM (OUTDOOR + INDOOR).

Multipliers for determining the performance with other indoor section.

HIGH CFM

Air Handler	Coil	MBH	COP	KW
-	FC/MC/PC48	1.03	0.89	1.16
AHV24B	-	0.98	0.88	1.11
AHV30B	-	0.99	0.91	1.10
AHV36C	-	0.99	0.94	1.06
MV12B	FC/MC43B	1.00	0.95	1.06
MV12D	FC/MC48D	1.00	1.00	1.00
MV12D	FC/MC60D	0.99	0.98	1.01

Furnace	Coil	MBH	COP	KW
T*9V*C20	UC48C	1.01	1.01	1.00
TM8X080C16MP11	FC/MC/PC43C	1.01	0.92	1.10
TM8X080C16MP11	FC/MC/PC48C	1.01	0.93	1.09
TM8X080C16MP11	FC/PC60C	1.01	0.93	1.08
TM8X080C16MP11	UC48C	1.02	0.96	1.06
TM8X080C16MP11	UC60C	1.01	0.93	1.08
TM8X100C16MP11	FC/MC/PC43C	1.01	0.92	1.10
TM8X100C16MP11	FC/MC/PC48C	1.01	0.93	1.09
TM8X100C16MP11	FC/PC60C	1.01	0.93	1.08
TM8X100C16MP11	UC48C	1.02	0.96	1.06
TM8X100C16MP11	UC60C	1.01	0.93	1.08
TMLX080C16MP11	FC/MC/PC43C	1.01	0.92	1.10
TMLX080C16MP11	FC/MC/PC48C	1.01	0.93	1.09
TMLX080C16MP11	FC/PC60C	1.01	0.93	1.08
TMLX080C16MP11	UC48C	1.02	0.96	1.06
TMLX080C16MP11	UC60C	1.01	0.93	1.08
TMLX100C16MP11	FC/MC/PC43C	1.01	0.92	1.10
TMLX100C16MP11	FC/MC/PC48C	1.01	0.93	1.09
TMLX100C16MP11	FC/PC60C	1.01	0.93	1.08
TMLX100C16MP11	UC48C	1.02	0.96	1.06
TMLX100C16MP11	UC60C	1.01	0.93	1.08

Furnace	Coil	MBH	COP	KW
T*(8,L)V*A12	FC/MC/PC37A	0.99	0.93	1.07
T*(8,L)V*B12	FC/MC/PC43B	0.99	0.94	1.05
T*(8,L)V*C16	FC/MC/PC43C	0.99	0.94	1.05
T*9V*A10	FC/MC/PC37A	1.01	0.91	1.11
T*9V*B12	FC/MC/PC43B	1.00	0.94	1.06
T*9V*C16	FC/MC/PC48C	1.01	0.98	1.03
T*9V*C16	FC/PC60C	1.01	0.98	1.03
T*9V*C16	UC48C	1.01	1.01	1.00
T*9V*C16	UC60C	1.01	0.98	1.03
T*9V*C20	FC/MC/PC43C	1.01	0.98	1.03
T*9V*C20	FC/MC/PC48C	1.01	0.98	1.03

HEATING PERFORMANCE DATA - LOW CFM 1-STAGE OPERATION										
OUTDOOR UNIT MODEL NO.		HL8B036F4C								
INDOOR COIL MODEL NO.		FC/MC62D + MV12D								
AIR TEMP. ENTERING OUTDOOR UNIT (°F)	AIR TEMP. ENTERING INDOOR COIL (°F)	ID CFM								
		725			775			825		
		MBH	COP	KW	MBH	COP	KW	MBH	COP	KW
60	60	29.70	4.08	2.13	30.60	4.67	1.92	31.40	5.42	1.70
	70	29.20	3.52	2.44	29.90	4.01	2.19	30.70	4.62	1.94
	80	28.70	3.08	2.74	29.30	3.49	2.46	29.90	4.00	2.19
47	60	25.30	3.62	2.05	25.80	4.04	1.87	26.30	4.54	1.70
	70	25.10	3.15	2.33	25.50	3.50	2.14	25.90	3.92	1.94
	80	24.90	2.78	2.62	25.20	3.08	2.40	25.60	3.44	2.18
40	60	22.60	3.34	1.99	23.10	3.71	1.82	23.50	4.15	1.66
	70	22.60	2.94	2.25	23.00	3.24	2.08	23.40	3.59	1.91
	80	22.60	2.63	2.52	22.90	2.87	2.34	23.20	3.15	2.16
30	60	-	-	-	-	-	-	-	-	-
	70	-	-	-	-	-	-	-	-	-
	80	-	-	-	-	-	-	-	-	-
17	60	-	-	-	-	-	-	-	-	-
	70	-	-	-	-	-	-	-	-	-
	80	-	-	-	-	-	-	-	-	-
10	60	-	-	-	-	-	-	-	-	-
	70	-	-	-	-	-	-	-	-	-
	80	-	-	-	-	-	-	-	-	-

NOTE: ALL CAPACITIES ARE NET, WITH INDOOR FAN HEAT ALREADY DEDUCTED. KW VALUES ARE FOR THE SYSTEM (OUTDOOR + INDOOR).

Multipliers for determining the performance with other indoor sections.

LOW CFM

Air Handler	Coil	MBH	COP	KW
-	FC/MC62	1.04	0.97	1.08
AHE42D	-	1.00	0.94	1.07
AHV36C	-	0.99	0.99	1.00
AHV42D	-	1.01	1.01	1.00
AHV48D	-	1.02	1.03	0.99
MV12B	FC/MC43B	1.02	0.99	1.03
MV12D	FC/MC48D	1.01	1.00	1.01
MV12D	FC/MC60D	1.01	0.97	1.04
MV12D	FC/MC62D	1.00	1.00	1.00
MV12D	FC64D	1.03	1.05	0.98
MV16C	FC/MC43C	0.99	0.97	1.03
MV16C	FC/MC48C	1.01	0.98	1.03
MV20D	FC/MC48D	1.03	1.03	1.00
MV20D	FC/MC60D	1.03	1.03	1.00
MV20D	FC/MC62D	1.02	1.03	0.98
MV20D	FC64D	1.05	1.08	0.97
MX12BN21	FC/MC43B	0.99	0.98	1.01
MX12DN21	FC/MC48D	1.00	1.02	0.98
MX12DN21	FC/MC60D	1.02	1.03	0.99
MX12DN21	FC64D	1.05	1.10	0.95

Continued on next page.

Furnace	Coil	MBH	COP	KW
T*(8,L)V*A12	FC/MC/PC37A	1.00	0.93	1.07
T*(8,L)V*B12	FC/MC/PC43B	1.03	0.99	1.04
T*(8,L)V*C16	FC/MC/PC43C	1.00	0.97	1.04
T*(8,L)V*C16	FC/MC/PC48C	1.01	0.95	1.06
T*(8,L)V*C16	FC/PC60C	1.02	0.96	1.06
T*(8,L)V*C16	UC48C	1.05	1.05	1.00
T*(8,L)V*C16	UC60C	1.00	0.95	1.05
T*(8,L)V*C20	FC/MC/PC43C	0.99	0.95	1.04
T*(8,L)V*C20	FC/MC/PC48C	1.00	0.95	1.05
T*(8,L)V*C20	FC/PC60C	1.02	1.00	1.02
T*(8,L)V*C20	UC48C	1.03	1.01	1.02
T*(8,L)V*C20	UC60C	1.00	0.95	1.05
T*9V*B12	FC/MC/PC43B	1.00	0.98	1.02
T*9V*C16	FC/MC/PC43C	1.02	0.98	1.03
T*9V*C16	FC/MC/PC48C	1.01	0.98	1.03
T*9V*C16	FC/PC60C	1.03	0.99	1.04
T*9V*C16	UC48C	1.03	1.03	1.00
T*9V*C16	UC60C	1.01	0.96	1.05
T*9V*C20	FC/MC/PC43C	0.99	0.97	1.02
T*9V*C20	FC/MC/PC48C	1.02	0.97	1.05
T*9V*C20	FC/PC60C	1.02	0.98	1.04
T*9V*C20	UC48C	1.05	1.02	1.03
T*9V*C20	UC60C	1.01	0.94	1.07
T*9V*D20	FC/MC/PC48D	1.02	1.01	1.01
T*9V*D20	FC/MC/PC60D	1.02	1.01	1.01
T*9V*D20	FC/MC62D	1.02	1.01	1.00
T*9V*D20	FC64D	1.05	1.06	0.99
T*9V*D20	UC48D	1.05	1.06	0.99
T*9V*D20	UC60D	1.01	0.97	1.04
TM8X060A12MP11	FC/MC/PC37A	1.00	0.97	1.04
TM8X080B12MP11	FC/MC/PC43B	1.00	0.97	1.04
TM8X080C16MP11	FC/MC/PC43C	0.99	0.98	1.02
TM8X080C16MP11	FC/MC/PC48C	1.01	1.00	1.01
TM8X080C16MP11	FC/MC/PC48D	1.01	1.00	1.01
TM8X080C16MP11	FC/MC/PC60D	1.02	1.01	1.00
TM8X080C16MP11	FC/MC62D	1.00	1.01	0.99
TM8X080C16MP11	FC/PC60C	1.02	1.01	1.01
TM8X080C16MP11	FC64D	1.03	1.05	0.98
TM8X080C16MP11	UC48C	1.03	1.05	0.99
TM8X080C16MP11	UC48D	1.03	1.04	0.99
TM8X080C16MP11	UC60C	0.99	0.97	1.03
TM8X080C16MP11	UC60D	0.99	0.97	1.03
TM8X100C16MP11	FC/MC/PC43C	0.99	0.98	1.02
TM8X100C16MP11	FC/MC/PC48C	1.01	1.00	1.01
TM8X100C16MP11	FC/MC/PC48D	1.01	1.00	1.01
TM8X100C16MP11	FC/MC/PC60D	1.02	1.01	1.00
TM8X100C16MP11	FC/MC62D	1.00	1.01	0.99
TM8X100C16MP11	FC/PC60C	1.02	1.01	1.01
TM8X100C16MP11	FC64D	1.03	1.05	0.98
TM8X100C16MP11	UC48C	1.03	1.05	0.99

Furnace	Coil	MBH	COP	KW
TM8X100C16MP11	UC48D	1.03	1.04	0.99
TM8X100C16MP11	UC60C	0.99	0.97	1.03
TM8X100C16MP11	UC60D	0.99	0.97	1.03
TMLX060A12MP11	FC/MC/PC37A	1.00	0.97	1.04
TMLX080B12MP11	FC/MC/PC43B	1.00	0.97	1.04
TMLX080C16MP11	FC/MC/PC43C	0.99	0.98	1.02
TMLX080C16MP11	FC/MC/PC48C	1.01	1.00	1.01
TMLX080C16MP11	FC/MC/PC48D	1.01	1.00	1.01
TMLX080C16MP11	FC/MC/PC60D	1.02	1.01	1.00
TMLX080C16MP11	FC/MC62D	1.00	1.01	0.99
TMLX080C16MP11	FC/PC60C	1.02	1.01	1.01
TMLX080C16MP11	FC64D	1.03	1.05	0.98
TMLX080C16MP11	UC48C	1.03	1.05	0.99
TMLX080C16MP11	UC48D	1.03	1.04	0.99
TMLX080C16MP11	UC60C	0.99	0.97	1.03
TMLX080C16MP11	UC60D	0.99	0.97	1.03
TMLX100C16MP11	FC/MC/PC43C	0.99	0.98	1.02
TMLX100C16MP11	FC/MC/PC48C	1.01	1.00	1.01
TMLX100C16MP11	FC/MC/PC48D	1.01	1.00	1.01
TMLX100C16MP11	FC/MC/PC60D	1.02	1.01	1.00
TMLX100C16MP11	FC/MC62D	1.00	1.01	0.99
TMLX100C16MP11	FC/PC60C	1.02	1.01	1.01
TMLX100C16MP11	FC64D	1.03	1.05	0.98
TMLX100C16MP11	UC48C	1.03	1.05	0.99
TMLX100C16MP11	UC48D	1.03	1.04	0.99
TMLX100C16MP11	UC60C	0.99	0.97	1.03
TMLX100C16MP11	UC60D	0.99	0.97	1.03
TM9E060B12MP11	FC/MC/PC43B	0.99	0.95	1.05
TM9E080B12MP11	FC/MC/PC43B	0.99	0.95	1.05
TM9E080C16MP11	FC/MC/PC48D	1.01	0.99	1.01
TM9E080C16MP11	FC/MC62D	0.99	1.00	0.99
TM9E080C16MP11	FC64D	1.03	1.05	0.99
TM9E080C16MP11	UC48D	1.03	1.04	0.99
TM9E100C16MP11	FC/MC/PC48D	1.01	0.99	1.01
TM9E100C16MP11	FC/MC62D	0.99	1.00	0.99
TM9E100C16MP11	FC64D	1.03	1.05	0.99
TM9E100C16MP11	UC48D	1.03	1.04	0.99
TM9X060B12MP11	FC/MC/PC43B	0.99	0.95	1.05
TM9X080B12MP11	FC/MC/PC43B	0.99	0.95	1.05
TM9X080C16MP11	FC/MC/PC48D	1.01	0.99	1.01
TM9X080C16MP11	FC/MC62D	0.99	1.00	0.99
TM9X080C16MP11	FC64D	1.03	1.05	0.99
TM9X080C16MP11	UC48D	1.03	1.04	0.99
TM9X100C16MP11	FC/MC/PC48D	1.01	0.99	1.01
TM9X100C16MP11	FC/MC62D	0.99	1.00	0.99
TM9X100C16MP11	FC64D	1.03	1.05	0.99
TM9X100C16MP11	UC48D	1.03	1.04	0.99

HEATING PERFORMANCE DATA - HIGH CFM 2-STAGE OPERATION										
OUTDOOR UNIT MODEL NO.		HL8B036F4C								
INDOOR COIL MODEL NO.		FC/MC62D + MV12D								
AIR TEMP. ENTERING OUTDOOR UNIT (°F)	AIR TEMP. ENTERING INDOOR COIL (°F)	ID CFM								
		1125			1225			1325		
		MBH	COP	KW	MBH	COP	KW	MBH	COP	KW
60	60	42.1	5.84	2.43	43.3	5.29	2.38	44.5	5.40	2.33
	70	41.2	5.24	2.65	42.3	4.79	2.60	43.4	4.90	2.55
	80	40.3	4.71	2.88	41.3	4.36	2.81	42.3	4.47	2.75
47	60	36.5	5.29	2.33	37.1	4.68	2.29	37.6	4.69	2.27
	70	35.3	4.65	2.55	36.0	4.20	2.51	36.7	4.26	2.46
	80	34.0	4.11	2.78	34.9	3.80	2.72	35.8	3.88	2.66
40	60	32.9	4.72	2.34	33.4	4.20	2.31	33.9	4.23	2.27
	70	32.5	4.22	2.59	32.9	3.81	2.54	33.4	3.86	2.48
	80	32.1	3.82	2.83	32.5	3.48	2.76	32.8	3.53	2.70
30	60	29.3	4.37	2.26	29.2	3.81	2.22	29.2	3.77	2.17
	70	28.7	3.89	2.49	29.0	3.47	2.45	29.3	3.47	2.41
	80	28.2	3.50	2.72	28.8	3.18	2.69	29.4	3.23	2.64
17	60	23.5	3.61	2.20	23.8	3.14	2.19	24.0	3.11	2.17
	70	23.7	3.30	2.43	24.0	2.92	2.41	24.3	2.91	2.38
	80	23.9	3.03	2.65	24.2	2.73	2.63	24.6	2.74	2.59
10	60	16.3	2.70	2.04	17.9	2.46	2.09	19.5	2.55	2.14
	70	18.4	2.69	2.31	19.4	2.42	2.32	20.3	2.47	2.34
	80	20.5	2.69	2.57	20.8	2.41	2.56	21.2	2.41	2.54

NOTE: ALL CAPACITIES ARE NET, WITH INDOOR FAN HEAT ALREADY DEDUCTED. KW VALUES ARE FOR THE SYSTEM (OUTDOOR + INDOOR).

Multipliers for determining the performance with other indoor sections.

HIGH CFM

Air Handler	Coil	MBH	COP	KW
-	FC/MC62	1.01	0.92	1.10
AHE42D	-	0.99	0.97	1.02
AHV36C	-	1.00	0.95	1.06
AHV42D	-	0.99	0.97	1.03
AHV48D	-	0.98	0.96	1.02
MV12B	FC/MC43B	1.00	0.95	1.05
MV12D	FC/MC48D	0.99	0.97	1.02
MV12D	FC/MC60D	0.99	0.94	1.05
MV12D	FC/MC62D	1.00	1.00	1.00
MV12D	FC64D	1.00	1.02	0.98
MV16C	FC/MC43C	0.99	0.96	1.04
MV16C	FC/MC48C	0.99	0.96	1.03
MV20D	FC/MC48D	1.00	1.00	1.00
MV20D	FC/MC60D	1.00	0.99	1.01
MV20D	FC/MC62D	1.00	1.01	0.99
MV20D	FC64D	1.01	1.04	0.97
MX12BN21	FC/MC43B	0.99	0.92	1.07
MX12DN21	FC/MC48D	0.98	0.96	1.02
MX12DN21	FC/MC60D	0.98	0.96	1.02
MX12DN21	FC64D	1.00	1.02	0.98

Continued on next page.

Furnace	Coil	MBH	COP	KW
T*(8,L)V*A12	FC/MC/PC37A	1.00	0.90	1.11
T*(8,L)V*B12	FC/MC/PC43B	1.01	0.93	1.09
T*(8,L)V*C16	FC/MC/PC43C	0.99	0.95	1.05
T*(8,L)V*C16	FC/MC/PC48C	0.99	0.97	1.03
T*(8,L)V*C16	FC/PC60C	0.98	0.94	1.04
T*(8,L)V*C16	UC48C	1.00	1.00	1.00
T*(8,L)V*C16	UC60C	0.99	0.94	1.05
T*(8,L)V*C20	FC/MC/PC43C	0.99	0.95	1.05
T*(8,L)V*C20	FC/MC/PC48C	0.99	0.96	1.03
T*(8,L)V*C20	FC/PC60C	0.99	0.96	1.03
T*(8,L)V*C20	UC48C	1.00	0.99	1.01
T*(8,L)V*C20	UC60C	0.99	0.94	1.05
T*9V*B12	FC/MC/PC43B	1.00	0.92	1.09
T*9V*C16	FC/MC/PC43C	1.00	0.94	1.07
T*9V*C16	FC/MC/PC48C	0.99	0.94	1.05
T*9V*C16	FC/PC60C	1.00	0.94	1.06
T*9V*C16	UC48C	1.00	0.97	1.03
T*9V*C16	UC60C	1.00	0.94	1.07
T*9V*C20	FC/MC/PC43C	0.99	0.94	1.05
T*9V*C20	FC/MC/PC48C	1.01	0.97	1.05
T*9V*C20	FC/PC60C	1.01	0.96	1.05
T*9V*C20	UC48C	1.03	0.99	1.04
T*9V*C20	UC60C	1.01	0.96	1.06
T*9V*D20	FC/MC/PC48D	1.00	0.97	1.03
T*9V*D20	FC/MC/PC60D	0.99	0.96	1.04
T*9V*D20	FC/MC62D	1.00	0.98	1.02
T*9V*D20	FC64D	1.01	1.01	1.00
T*9V*D20	UC48D	1.01	1.00	1.02
T*9V*D20	UC60D	0.99	0.95	1.05
TM8X060A12MP11	FC/MC/PC37A	0.99	0.90	1.10
TM8X080B12MP11	FC/MC/PC43B	0.99	0.90	1.10
TM8X080C16MP11	FC/MC/PC43C	0.99	0.93	1.06
TM8X080C16MP11	FC/MC/PC48C	0.99	0.95	1.04
TM8X080C16MP11	FC/MC/PC48D	0.99	0.95	1.04
TM8X080C16MP11	FC/MC/PC60D	0.99	0.95	1.04
TM8X080C16MP11	FC/MC62D	0.99	0.97	1.02
TM8X080C16MP11	FC/PC60C	0.99	0.95	1.04
TM8X080C16MP11	FC64D	1.00	1.00	1.00
TM8X080C16MP11	UC48C	1.00	0.98	1.02
TM8X080C16MP11	UC48D	1.00	0.98	1.02
TM8X080C16MP11	UC60C	0.99	0.94	1.05
TM8X080C16MP11	UC60D	0.99	0.94	1.05
TM8X100C16MP11	FC/MC/PC43C	0.99	0.93	1.06
TM8X100C16MP11	FC/MC/PC48C	0.99	0.95	1.04
TM8X100C16MP11	FC/MC/PC48D	0.99	0.95	1.04
TM8X100C16MP11	FC/MC/PC60D	0.99	0.95	1.04
TM8X100C16MP11	FC/MC62D	0.99	0.97	1.02
TM8X100C16MP11	FC/PC60C	0.99	0.95	1.04
TM8X100C16MP11	FC64D	1.00	1.00	1.00
TM8X100C16MP11	UC48C	1.00	0.98	1.02
TM8X100C16MP11	UC48D	1.00	0.98	1.02
TM8X100C16MP11	UC60C	0.99	0.94	1.05
TM8X100C16MP11	UC60D	0.99	0.94	1.05
TM8X100C16MP11	FC/MC/PC43C	0.99	0.93	1.06
TM8X100C16MP11	FC/MC/PC48C	0.99	0.95	1.04
TM8X100C16MP11	FC/MC/PC48D	0.99	0.95	1.04
TM8X100C16MP11	FC/MC/PC60D	0.99	0.95	1.04
TM8X100C16MP11	FC/MC62D	0.99	0.97	1.02
TM8X100C16MP11	FC/PC60C	0.99	0.95	1.04
TM8X100C16MP11	FC64D	1.00	1.00	1.00
TM8X100C16MP11	UC48C	1.00	0.98	1.02

Furnace	Coil	MBH	COP	KW
TM8X100C16MP11	UC48D	1.00	0.98	1.02
TM8X100C16MP11	UC60C	0.99	0.94	1.05
TM8X100C16MP11	UC60D	0.99	0.94	1.05
TMLX060A12MP11	FC/MC/PC37A	0.99	0.90	1.10
TMLX080B12MP11	FC/MC/PC43B	0.99	0.90	1.10
TMLX080C16MP11	FC/MC/PC43C	0.99	0.93	1.06
TMLX080C16MP11	FC/MC/PC48C	0.99	0.95	1.04
TMLX080C16MP11	FC/MC/PC48D	0.99	0.95	1.04
TMLX080C16MP11	FC/MC/PC60D	0.99	0.95	1.04
TMLX080C16MP11	FC/MC62D	0.99	0.97	1.02
TMLX080C16MP11	FC/PC60C	0.99	0.95	1.04
TMLX080C16MP11	FC64D	1.00	1.00	1.00
TMLX080C16MP11	UC48C	1.00	0.98	1.02
TMLX080C16MP11	UC48D	1.00	0.98	1.02
TMLX080C16MP11	UC60C	0.99	0.94	1.05
TMLX080C16MP11	UC60D	0.99	0.94	1.05
TMLX100C16MP11	FC/MC/PC43C	0.99	0.93	1.06
TMLX100C16MP11	FC/MC/PC48C	0.99	0.95	1.04
TMLX100C16MP11	FC/MC/PC48D	0.99	0.95	1.04
TMLX100C16MP11	FC/MC/PC60D	0.99	0.95	1.04
TMLX100C16MP11	FC/MC62D	0.99	0.97	1.02
TMLX100C16MP11	FC/PC60C	0.99	0.95	1.04
TMLX100C16MP11	FC64D	1.00	1.00	1.00
TMLX100C16MP11	UC48C	1.00	0.98	1.02
TMLX100C16MP11	UC48D	1.00	0.98	1.02
TMLX100C16MP11	UC60C	0.99	0.94	1.05
TMLX100C16MP11	UC60D	0.99	0.94	1.05
TM9E060B12MP11	FC/MC/PC43B	0.99	0.90	1.10
TM9E080B12MP11	FC/MC/PC43B	0.99	0.90	1.10
TM9E080C16MP11	FC/MC/PC48D	0.99	0.94	1.05
TM9E080C16MP11	FC/MC62D	1.00	0.96	1.04
TM9E080C16MP11	FC64D	1.01	0.99	1.03
TM9E080C16MP11	UC48D	1.00	0.97	1.03
TM9E100C16MP11	FC/MC/PC48D	0.99	0.94	1.05
TM9E100C16MP11	FC/MC62D	1.00	0.96	1.04
TM9E100C16MP11	FC64D	1.01	0.99	1.03
TM9E100C16MP11	UC48D	1.00	0.97	1.03
TM9X060B12MP11	FC/MC/PC43B	0.99	0.90	1.10
TM9X080B12MP11	FC/MC/PC43B	0.99	0.90	1.10
TM9X080C16MP11	FC/MC/PC48D	0.99	0.94	1.05
TM9X080C16MP11	FC/MC62D	1.00	0.96	1.04
TM9X080C16MP11	FC64D	1.01	0.99	1.03
TM9X080C16MP11	UC48D	1.00	0.97	1.03
TM9X100C16MP11	FC/MC/PC48D	0.99	0.94	1.05
TM9X100C16MP11	FC/MC62D	1.00	0.96	1.04
TM9X100C16MP11	FC64D	1.01	0.99	1.03
TM9X100C16MP11	UC48D	1.00	0.97	1.03

HEATING PERFORMANCE DATA - LOW CFM 1-STAGE OPERATION										
OUTDOOR UNIT MODEL NO.		HL8B048F4C								
INDOOR COIL MODEL NO.		FC/MC62D + MV20D								
AIR TEMP. ENTERING OUTDOOR UNIT (°F)	AIR TEMP. ENTERING INDOOR COIL (°F)	ID CFM								
		1025			1075			1125		
		MBH	COP	KW	MBH	COP	KW	MBH	COP	KW
60	60	40.00	4.31	2.72	40.70	4.65	2.57	41.40	5.04	2.41
	70	39.40	3.70	3.12	40.00	4.00	2.93	40.60	4.33	2.75
	80	38.70	3.23	3.51	39.30	3.49	3.30	39.90	3.78	3.09
47	60	34.10	3.81	2.62	34.60	4.05	2.50	35.10	4.32	2.38
	70	33.40	3.29	2.98	34.00	3.50	2.85	34.60	3.74	2.71
	80	32.80	2.87	3.34	33.40	3.07	3.19	34.00	3.28	3.04
40	60	30.80	3.51	2.57	31.20	3.70	2.47	31.60	3.90	2.38
	70	30.40	3.04	2.93	30.80	3.21	2.81	31.20	3.40	2.69
	80	29.90	2.67	3.28	30.30	2.83	3.14	30.80	3.00	3.01
30	60	-	-	-	-	-	-	-	-	-
	70	-	-	-	-	-	-	-	-	-
	80	-	-	-	-	-	-	-	-	-
17	60	-	-	-	-	-	-	-	-	-
	70	-	-	-	-	-	-	-	-	-
	80	-	-	-	-	-	-	-	-	-
10	60	-	-	-	-	-	-	-	-	-
	70	-	-	-	-	-	-	-	-	-
	80	-	-	-	-	-	-	-	-	-

NOTE: ALL CAPACITIES ARE NET, WITH INDOOR FAN HEAT ALREADY DEDUCTED. KW VALUES ARE FOR THE SYSTEM (OUTDOOR + INDOOR).

Multipliers for determining the performance with other indoor sections.

LOW CFM

Air Handler	Coil	MBH	COP	KW
-	FC/MC62	1.04	0.95	1.09
AHE60D	-	1.01	1.01	0.99
AHV48D	-	1.00	0.95	1.05
AHV60D	-	0.99	0.97	1.02
MV16C	FC/MC48C	1.00	0.96	1.04
MV16C	FC60C	1.01	0.95	1.06
MV20D	FC/MC48D	0.99	0.96	1.04
MV20D	FC/MC60D	1.01	0.94	1.07
MV20D	FC/MC62D	1.00	1.00	1.00
MV20D	FC64D	1.01	1.03	0.98
MX16CN21	FC/MC48C	0.99	0.97	1.02
MX16CN21	FC60C	1.00	0.97	1.04

Furnace	Coil	MBH	COP	KW
T*(8,L)V*C20	UC48C	1.03	0.99	1.04
T*(8,L)V*C20	UC60C	0.99	0.92	1.07
T*9V*C16	FC/MC/PC48C	1.00	0.94	1.06
T*9V*C16	FC/MC/PC48D	1.00	0.94	1.06
T*9V*C16	FC/MC/PC60D	1.01	0.94	1.08
T*9V*C16	FC/MC62D	1.01	0.97	1.04
T*9V*C16	FC/PC60C	1.01	0.94	1.08
T*9V*C16	FC64D	1.02	1.01	1.02
T*9V*C16	UC48C	1.02	0.98	1.05
T*9V*C16	UC60C	0.99	0.91	1.09
T*9V*C20	FC/MC/PC48C	1.00	0.95	1.05
T*9V*C20	FC/MC/PC48D	1.00	0.95	1.05
T*9V*C20	FC/MC/PC60D	1.01	0.94	1.07
T*9V*C20	FC/MC62D	1.00	0.97	1.04
T*9V*C20	FC/PC60C	1.01	0.94	1.07
T*9V*C20	FC64D	1.02	1.01	1.02
T*9V*C20	UC48C	1.03	0.99	1.04
T*9V*C20	UC60C	1.00	0.93	1.08
T*9V*D20	FC/MC/PC48D	1.00	0.94	1.06
T*9V*D20	FC/MC/PC60D	1.01	0.94	1.08
T*9V*D20	FC/MC62D	1.01	0.98	1.03
T*9V*D20	FC64D	1.02	1.00	1.02
T*9V*D20	UC48D	1.03	0.99	1.04
T*9V*D20	UC60D	0.99	0.93	1.07
TM8X080C16MP11	FC/MC/PC48C	0.99	0.96	1.04
TM8X080C16MP11	FC/MC/PC48D	0.99	0.96	1.04
TM8X080C16MP11	FC/MC/PC60D	1.01	0.95	1.05

Continued on next page.

Furnace	Coil	MBH	COP	KW
TM8X080C16MP11	FC/MC62D	0.99	0.98	1.02
TM8X080C16MP11	FC/PC60C	1.00	0.95	1.05
TM8X080C16MP11	FC64D	1.02	1.02	0.99
TM8X080C16MP11	UC48C	1.02	0.99	1.02
TM8X080C16MP11	UC48D	1.02	0.99	1.02
TM8X080C16MP11	UC60C	0.99	0.93	1.07
TM8X080C16MP11	UC60D	0.99	0.93	1.07
TM8X100C16MP11	FC/MC/PC48C	0.99	0.96	1.04
TM8X100C16MP11	FC/MC/PC48D	0.99	0.96	1.04
TM8X100C16MP11	FC/MC/PC60D	1.01	0.95	1.05
TM8X100C16MP11	FC/MC62D	0.99	0.98	1.02
TM8X100C16MP11	FC/PC60C	1.00	0.95	1.05
TM8X100C16MP11	FC64D	1.02	1.02	0.99
TM8X100C16MP11	UC48C	1.02	0.99	1.02
TM8X100C16MP11	UC48D	1.02	0.99	1.02
TM8X100C16MP11	UC60C	0.99	0.93	1.07
TM8X100C16MP11	UC60D	0.99	0.93	1.07
TM8X100C20MP11	FC/MC/PC48C	1.01	0.98	1.03
TM8X100C20MP11	FC/MC/PC48D	1.01	0.98	1.02
TM8X100C20MP11	FC/MC/PC60D	1.01	0.97	1.04
TM8X100C20MP11	FC/MC62D	1.00	0.99	1.01
TM8X100C20MP11	FC/PC60C	1.01	0.95	1.06
TM8X100C20MP11	UC48C	1.02	1.01	1.01
TM8X100C20MP11	UC48D	1.02	1.02	1.01
TM8X100C20MP11	UC60C	0.99	0.95	1.04
TM8X100C20MP11	UC60D	0.99	0.95	1.04
TM8X120C20MP11	FC/MC/PC48C	1.01	0.98	1.03
TM8X120C20MP11	FC/MC/PC48D	1.01	0.98	1.02
TM8X120C20MP11	FC/MC/PC60D	1.01	0.97	1.04
TM8X120C20MP11	FC/MC62D	1.00	0.99	1.01
TM8X120C20MP11	FC/PC60C	1.01	0.95	1.06
TM8X120C20MP11	UC48C	1.02	1.01	1.01
TM8X120C20MP11	UC48D	1.02	1.02	1.01
TM8X120C20MP11	UC60C	0.99	0.95	1.04
TM8X120C20MP11	UC60D	0.99	0.95	1.04
TM8X120C20MP11	FC/MC/PC48C	1.01	0.98	1.03
TM8X120C20MP11	FC/MC/PC48D	1.01	0.98	1.02
TM8X120C20MP11	FC/MC/PC60D	1.01	0.97	1.04
TM8X120C20MP11	FC/MC62D	1.00	0.99	1.01
TM8X120C20MP11	FC/PC60C	1.01	0.95	1.06
TM8X120C20MP11	UC48C	1.02	1.01	1.01
TM8X120C20MP11	UC48D	1.02	1.02	1.01
TM8X120C20MP11	UC60C	0.99	0.95	1.04
TM8X120C20MP11	UC60D	0.99	0.95	1.04
TM8X120C20MP11	FC/MC/PC48C	1.01	0.98	1.03
TM8X120C20MP11	FC/MC/PC48D	1.01	0.98	1.02
TM8X120C20MP11	FC/MC/PC60D	1.01	0.97	1.04
TM8X120C20MP11	FC/MC62D	1.00	0.99	1.01
TM8X120C20MP11	FC/PC60C	1.01	0.95	1.06
TM8X120C20MP11	UC48C	1.02	1.01	1.01
TM8X120C20MP11	UC48D	1.02	1.02	1.01
TM8X120C20MP11	UC60C	0.99	0.95	1.04
TM8X120C20MP11	UC60D	0.99	0.95	1.04
TM8X120C20MP11	FC/MC/PC48C	1.01	0.98	1.03
TM8X120C20MP11	FC/MC/PC48D	1.01	0.98	1.02
TM8X120C20MP11	FC/MC/PC60D	1.01	0.97	1.04
TM8X120C20MP11	FC/MC62D	1.00	0.99	1.01
TM8X120C20MP11	FC/PC60C	1.01	0.95	1.06
TM8X120C20MP11	UC48C	1.02	1.01	1.01
TM8X120C20MP11	UC48D	1.02	1.02	1.01
TM8X120C20MP11	UC60C	0.99	0.95	1.04
TM8X120C20MP11	UC60D	0.99	0.95	1.04
TMLX080C16MP11	FC/MC/PC48C	0.99	0.96	1.04
TMLX080C16MP11	FC/MC/PC48D	0.99	0.96	1.04
TMLX080C16MP11	FC/MC/PC60D	1.01	0.95	1.05
TMLX080C16MP11	FC/MC62D	0.99	0.98	1.02
TMLX080C16MP11	FC/PC60C	1.00	0.95	1.05
TMLX080C16MP11	FC64D	1.02	1.02	0.99
TMLX080C16MP11	UC48C	1.02	0.99	1.02
TMLX080C16MP11	UC48D	1.02	0.99	1.02
TMLX080C16MP11	UC60C	0.99	0.93	1.07
TMLX080C16MP11	UC60D	0.99	0.93	1.07
TMLX100C16MP11	FC/MC/PC48C	0.99	0.96	1.04
TMLX100C16MP11	FC/MC/PC48D	0.99	0.96	1.04
TMLX100C16MP11	FC/MC/PC60D	1.01	0.95	1.05
TMLX100C16MP11	FC/MC62D	0.99	0.98	1.02
TMLX100C16MP11	FC/PC60C	1.00	0.95	1.05
TMLX100C16MP11	FC64D	1.02	1.02	0.99
TMLX100C16MP11	UC48C	1.02	0.99	1.02

Furnace	Coil	MBH	COP	KW
TMLX100C16MP11	UC48D	1.02	0.99	1.02
TMLX100C16MP11	UC60C	0.99	0.93	1.07
TMLX100C16MP11	UC60D	0.99	0.93	1.07
TMLX100C20MP11	FC/MC/PC48C	1.01	0.98	1.03
TMLX100C20MP11	FC/MC/PC48D	1.01	0.98	1.02
TMLX100C20MP11	FC/MC/PC60D	1.01	0.97	1.04
TMLX100C20MP11	FC/MC62D	1.00	0.99	1.01
TMLX100C20MP11	FC/PC60C	1.01	0.95	1.06
TMLX100C20MP11	UC48C	1.02	1.01	1.01
TMLX100C20MP11	UC48D	1.02	1.02	1.01
TMLX100C20MP11	UC60C	0.99	0.95	1.04
TMLX100C20MP11	UC60D	0.99	0.95	1.04
TMLX120C20MP11	FC/MC/PC48C	1.01	0.98	1.03
TMLX120C20MP11	FC/MC/PC48D	1.01	0.98	1.02
TMLX120C20MP11	FC/MC/PC60D	1.01	0.97	1.04
TMLX120C20MP11	FC/MC62D	1.00	0.99	1.01
TMLX120C20MP11	FC/PC60C	1.01	0.95	1.06
TMLX120C20MP11	UC48C	1.02	1.01	1.01
TMLX120C20MP11	UC48D	1.02	1.02	1.01
TMLX120C20MP11	UC60C	0.99	0.95	1.04
TMLX120C20MP11	UC60D	0.99	0.95	1.04
TM9E100C20MP11	FC/MC/PC48C	0.99	0.93	1.07
TM9E100C20MP11	FC/MC/PC48D	0.99	0.93	1.07
TM9E100C20MP11	FC/MC/PC60D	1.00	0.92	1.09
TM9E100C20MP11	FC/MC62D	0.99	0.96	1.04
TM9E100C20MP11	FC64D	1.01	0.99	1.02
TM9E100C20MP11	UC48C	1.01	0.97	1.04
TM9E100C20MP11	UC48D	1.02	0.98	1.04
TM9E100C20MP11	UC60D	0.98	0.90	1.09
TM9E120D20MP11	FC/MC/PC48D	0.99	0.94	1.06
TM9E120D20MP11	FC/MC/PC60D	1.00	0.93	1.07
TM9E120D20MP11	FC/MC62D	0.99	0.96	1.04
TM9E120D20MP11	FC64D	1.01	0.99	1.02
TM9E120D20MP11	UC48D	1.01	0.98	1.03
TM9E120D20MP11	UC60D	0.98	0.93	1.05
TM9X100C20MP11	FC/MC/PC48C	0.99	0.93	1.07
TM9X100C20MP11	FC/MC/PC48D	0.99	0.93	1.07
TM9X100C20MP11	FC/MC/PC60D	1.00	0.92	1.09
TM9X100C20MP11	FC/MC62D	0.99	0.96	1.04
TM9X100C20MP11	FC64D	1.01	0.99	1.02
TM9X100C20MP11	UC48C	1.01	0.97	1.04
TM9X100C20MP11	UC48D	1.02	0.98	1.04
TM9X100C20MP11	UC60D	0.98	0.90	1.09
TM9X120D20MP11	FC/MC/PC48D	0.99	0.94	1.06
TM9X120D20MP11	FC/MC/PC60D	1.00	0.93	1.07
TM9X120D20MP11	FC/MC62D	0.99	0.96	1.04
TM9X120D20MP11	FC64D	1.01	0.99	1.02
TM9X120D20MP11	UC48D	1.01	0.98	1.03
TM9X120D20MP11	UC60D	0.98	0.93	1.05
TM9X120D20MP11	FC/MC/PC48C	0.99	0.93	1.07
TM9X120D20MP11	FC/MC/PC48D	0.99	0.93	1.07
TM9X120D20MP11	FC/MC/PC60D	1.00	0.92	1.09
TM9X120D20MP11	FC/MC62D	0.99	0.96	1.04
TM9X120D20MP11	FC64D	1.01	0.99	1.02
TM9X120D20MP11	UC48D	1.01	0.98	1.03
TM9X120D20MP11	UC60D	0.98	0.93	1.05

HEATING PERFORMANCE DATA - HIGH CFM 2-STAGE OPERATION										
OUTDOOR UNIT MODEL NO.		HL8B048F4C								
INDOOR COIL MODEL NO.		FC/MC62D + MV20D								
AIR TEMP. ENTERING OUTDOOR UNIT (°F)	AIR TEMP. ENTERING INDOOR COIL (°F)	ID CFM								
		1550			1650			1750		
		MBH	COP	KW	MBH	COP	KW	MBH	COP	KW
60	60	56.2	4.79	3.44	57.1	4.91	3.40	57.9	5.04	3.37
	70	54.9	4.31	3.73	55.7	4.43	3.68	56.5	4.55	3.64
	80	53.6	3.91	4.02	54.3	4.02	3.96	55.1	4.13	3.91
47	60	48.4	4.40	3.23	49.0	4.49	3.20	49.6	4.59	3.17
	70	47.5	3.88	3.59	48.0	3.98	3.53	48.5	4.09	3.48
	80	46.5	3.46	3.94	47.0	3.56	3.87	47.4	3.66	3.80
40	60	42.1	3.76	3.28	43.0	3.88	3.25	43.8	4.01	3.20
	70	42.1	3.45	3.58	41.9	3.46	3.55	41.7	3.48	3.52
	80	42.2	3.19	3.88	40.9	3.10	3.86	39.6	3.02	3.84
30	60	31.9	3.10	3.02	34.2	3.28	3.06	36.5	3.45	3.10
	70	34.6	2.98	3.40	36.1	3.09	3.42	37.6	3.22	3.43
	80	37.2	2.88	3.78	38.0	2.95	3.77	38.8	3.02	3.76
17	60	31.8	3.10	3.00	32.4	3.16	3.00	32.9	3.20	3.01
	70	31.3	2.79	3.28	31.8	2.84	3.28	32.3	2.88	3.29
	80	30.7	2.53	3.56	31.2	2.57	3.56	31.7	2.61	3.57
10	60	28.0	2.73	3.00	26.9	2.66	2.97	25.9	2.58	2.94
	70	26.0	2.38	3.21	26.2	2.39	3.22	26.5	2.40	3.23
	80	24.0	2.06	3.42	25.5	2.16	3.47	27.0	2.25	3.52

NOTE: ALL CAPACITIES ARE NET, WITH INDOOR FAN HEAT ALREADY DEDUCTED. KW VALUES ARE FOR THE SYSTEM (OUTDOOR + INDOOR).

Multipliers for determining the performance with other indoor sections.

HIGH CFM

Air Handler	Coil	MBH	COP	KW
-	FC/MC62	1.01	0.94	1.07
AHE60D	-	0.99	0.99	1.00
AHV48D	-	0.99	0.94	1.05
AHV60D	-	1.00	0.97	1.03
MV16C	FC/MC48C	1.00	0.96	1.04
MV16C	FC60C	1.00	0.95	1.05
MV20D	FC/MC48D	1.00	0.97	1.03
MV20D	FC/MC60D	1.00	0.95	1.05
MV20D	FC/MC62D	1.00	1.00	1.00
MV20D	FC64D	1.01	1.02	0.99
MX16CN21	FC/MC48C	1.00	0.96	1.04
MX16CN21	FC60C	1.00	0.94	1.06

Furnace	Coil	MBH	COP	KW
T*(8,L)V*C20	UC48C	1.01	0.96	1.05
T*(8,L)V*C20	UC60C	1.00	0.94	1.06
T*9V*C16	FC/MC/PC48C	1.01	0.94	1.08
T*9V*C16	FC/MC/PC48D	1.01	0.94	1.08
T*9V*C16	FC/MC/PC60D	1.00	0.92	1.08
T*9V*C16	FC/MC62D	1.01	0.95	1.06
T*9V*C16	FC/PC60C	1.00	0.92	1.08
T*9V*C16	FC64D	1.02	0.99	1.03
T*9V*C16	UC48C	1.01	0.94	1.08
T*9V*C16	UC60C	1.00	0.90	1.11
T*9V*C20	FC/MC/PC48C	1.01	0.94	1.08
T*9V*C20	FC/MC/PC48D	1.01	0.94	1.08
T*9V*C20	FC/MC/PC60D	1.00	0.92	1.08
T*9V*C20	FC/MC62D	1.01	0.95	1.06
T*9V*C20	FC/PC60C	1.00	0.92	1.08
T*9V*C20	FC64D	1.02	0.98	1.04
T*9V*C20	UC48C	1.01	0.96	1.05
T*9V*C20	UC60C	1.00	0.93	1.08
T*9V*D20	FC/MC/PC48D	1.01	0.94	1.08
T*9V*D20	FC/MC/PC60D	1.00	0.93	1.08
T*9V*D20	FC/MC62D	1.01	0.96	1.05
T*9V*D20	FC64D	1.02	0.99	1.03
T*9V*D20	UC48D	1.01	0.96	1.05
T*9V*D20	UC60D	1.00	0.93	1.08
TM8X080C16MP11	FC/MC/PC48C	1.00	0.93	1.08
TM8X080C16MP11	FC/MC/PC48D	1.00	0.95	1.05
TM8X080C16MP11	FC/MC/PC60D	1.00	0.93	1.07

Continued on next page.

Furnace	Coil	MBH	COP	KW
TM8X080C16MP11	FC/MC62D	1.00	0.95	1.05
TM8X080C16MP11	FC/PC60C	1.00	0.91	1.10
TM8X080C16MP11	FC64D	1.01	0.99	1.02
TM8X080C16MP11	UC48C	1.01	0.95	1.06
TM8X080C16MP11	UC48D	1.00	0.95	1.05
TM8X080C16MP11	UC60C	1.00	0.91	1.10
TM8X080C16MP11	UC60D	1.00	0.91	1.10
TM8X100C16MP11	FC/MC/PC48C	1.00	0.93	1.08
TM8X100C16MP11	FC/MC/PC48D	1.00	0.95	1.05
TM8X100C16MP11	FC/MC/PC60D	1.00	0.93	1.07
TM8X100C16MP11	FC/MC62D	1.00	0.95	1.05
TM8X100C16MP11	FC/PC60C	1.00	0.91	1.10
TM8X100C16MP11	FC64D	1.01	0.99	1.02
TM8X100C16MP11	UC48C	1.01	0.95	1.06
TM8X100C16MP11	UC48D	1.00	0.95	1.05
TM8X100C16MP11	UC60C	1.00	0.91	1.10
TM8X100C16MP11	UC60D	1.00	0.91	1.10
TM8X100C20MP11	FC/MC/PC48C	1.00	0.94	1.06
TM8X100C20MP11	FC/MC/PC48D	1.00	0.94	1.06
TM8X100C20MP11	FC/MC/PC60D	1.00	0.93	1.07
TM8X100C20MP11	FC/MC62D	1.00	0.96	1.04
TM8X100C20MP11	FC/PC60C	1.00	0.94	1.06
TM8X100C20MP11	UC48C	1.00	0.96	1.04
TM8X100C20MP11	UC48D	1.00	0.97	1.03
TM8X100C20MP11	UC60C	0.99	0.92	1.07
TM8X100C20MP11	UC60D	1.00	0.93	1.08
TM8X120C20MP11	FC/MC/PC48C	1.00	0.94	1.06
TM8X120C20MP11	FC/MC/PC48D	1.00	0.94	1.06
TM8X120C20MP11	FC/MC/PC60D	1.00	0.93	1.07
TM8X120C20MP11	FC/MC62D	1.00	0.96	1.04
TM8X120C20MP11	FC/PC60C	1.00	0.94	1.06
TM8X120C20MP11	UC48C	1.00	0.96	1.04
TM8X120C20MP11	UC48D	1.00	0.97	1.03
TM8X120C20MP11	UC60C	0.99	0.92	1.07
TM8X120C20MP11	UC60D	1.00	0.93	1.08
TM8X120C20MP11	FC/MC/PC48C	1.00	0.93	1.08
TM8X120C20MP11	FC/MC/PC48D	1.00	0.95	1.05
TM8X120C20MP11	FC/MC/PC60D	1.00	0.93	1.07
TM8X120C20MP11	FC/MC62D	1.00	0.95	1.05
TM8X120C20MP11	FC/PC60C	1.00	0.91	1.10
TM8X120C20MP11	FC64D	1.01	0.99	1.02
TM8X120C20MP11	UC48C	1.01	0.95	1.06
TM8X120C20MP11	UC48D	1.00	0.95	1.05
TM8X120C20MP11	UC60C	1.00	0.91	1.10
TM8X120C20MP11	UC60D	1.00	0.91	1.10
TM8X120C20MP11	FC/MC/PC48C	1.00	0.93	1.08
TM8X120C20MP11	FC/MC/PC48D	1.00	0.95	1.05
TM8X120C20MP11	FC/MC/PC60D	1.00	0.93	1.07
TM8X120C20MP11	FC/MC62D	1.00	0.95	1.05
TM8X120C20MP11	FC/PC60C	1.00	0.91	1.10
TM8X120C20MP11	FC64D	1.01	0.99	1.02
TM8X120C20MP11	UC48C	1.01	0.95	1.06

Furnace	Coil	MBH	COP	KW
TMLX100C16MP11	UC48D	1.00	0.95	1.05
TMLX100C16MP11	UC60C	1.00	0.91	1.10
TMLX100C16MP11	UC60D	1.00	0.91	1.10
TMLX100C20MP11	FC/MC/PC48C	1.00	0.94	1.06
TMLX100C20MP11	FC/MC/PC48D	1.00	0.94	1.06
TMLX100C20MP11	FC/MC/PC60D	1.00	0.93	1.07
TMLX100C20MP11	FC/MC62D	1.00	0.96	1.04
TMLX100C20MP11	FC/PC60C	1.00	0.94	1.06
TMLX100C20MP11	UC48C	1.00	0.96	1.04
TMLX100C20MP11	UC48D	1.00	0.97	1.03
TMLX100C20MP11	UC60C	0.99	0.92	1.07
TMLX100C20MP11	UC60D	1.00	0.93	1.08
TMLX120C20MP11	FC/MC/PC48C	1.00	0.94	1.06
TMLX120C20MP11	FC/MC/PC48D	1.00	0.94	1.06
TMLX120C20MP11	FC/MC/PC60D	1.00	0.93	1.07
TMLX120C20MP11	FC/MC62D	1.00	0.96	1.04
TMLX120C20MP11	FC/PC60C	1.00	0.94	1.06
TMLX120C20MP11	UC48C	1.00	0.96	1.04
TMLX120C20MP11	UC48D	1.00	0.97	1.03
TMLX120C20MP11	UC60C	0.99	0.92	1.07
TMLX120C20MP11	UC60D	1.00	0.93	1.08
TM9E100C20MP11	FC/MC/PC48C	1.00	0.91	1.09
TM9E100C20MP11	FC/MC/PC48D	1.00	0.93	1.08
TM9E100C20MP11	FC/MC/PC60D	1.00	0.91	1.09
TM9E100C20MP11	FC/MC62D	1.00	0.95	1.05
TM9E100C20MP11	FC64D	1.01	0.98	1.03
TM9E100C20MP11	UC48C	1.01	0.94	1.08
TM9E100C20MP11	UC48D	1.01	0.95	1.06
TM9E100C20MP11	UC60D	1.00	0.91	1.10
TM9E120D20MP11	FC/MC/PC48D	1.00	0.93	1.08
TM9E120D20MP11	FC/MC/PC60D	1.00	0.92	1.08
TM9E120D20MP11	FC/MC62D	1.00	0.95	1.05
TM9E120D20MP11	FC64D	1.01	0.97	1.04
TM9E120D20MP11	UC48D	1.00	0.95	1.05
TM9E120D20MP11	UC60D	0.99	0.91	1.08
TM9X100C20MP11	FC/MC/PC48C	1.00	0.91	1.09
TM9X100C20MP11	FC/MC/PC48D	1.00	0.93	1.08
TM9X100C20MP11	FC/MC/PC60D	1.00	0.91	1.09
TM9X100C20MP11	FC/MC62D	1.00	0.95	1.05
TM9X100C20MP11	FC64D	1.01	0.98	1.03
TM9X100C20MP11	UC48C	1.01	0.94	1.08
TM9X100C20MP11	UC48D	1.01	0.95	1.06
TM9X100C20MP11	UC60D	1.00	0.91	1.10
TM9X120D20MP11	FC/MC/PC48D	1.00	0.93	1.08
TM9X120D20MP11	FC/MC/PC60D	1.00	0.92	1.08
TM9X120D20MP11	FC/MC62D	1.00	0.95	1.05
TM9X120D20MP11	FC64D	1.01	0.97	1.04
TM9X120D20MP11	UC48D	1.00	0.95	1.05
TM9X120D20MP11	UC60D	0.99	0.91	1.08
TM9X120D20MP11	FC/MC/PC48C	1.00	0.91	1.09
TM9X120D20MP11	FC/MC/PC48D	1.00	0.93	1.08
TM9X120D20MP11	FC/MC/PC60D	1.00	0.91	1.09
TM9X120D20MP11	FC/MC62D	1.00	0.95	1.05
TM9X120D20MP11	FC64D	1.01	0.97	1.04
TM9X120D20MP11	UC48D	1.00	0.95	1.05
TM9X120D20MP11	UC60D	0.99	0.91	1.08

HEATING PERFORMANCE DATA - LOW CFM 1-STAGE OPERATION										
OUTDOOR UNIT MODEL NO.		HL8B060F4C								
INDOOR COIL MODEL NO.		FC/MC62D + MV20D								
AIR TEMP. ENTERING OUTDOOR UNIT (°F)	AIR TEMP. ENTERING INDOOR COIL (°F)	ID CFM								
		1125			1175			1225		
		MBH	COP	KW	MBH	COP	KW	MBH	COP	KW
60	60	48.10	3.91	3.61	48.70	4.21	3.39	49.40	4.56	3.17
	70	47.30	3.38	4.10	47.90	3.64	3.86	48.50	3.93	3.62
	80	46.40	2.96	4.60	47.10	3.19	4.33	47.70	3.44	4.06
47	60	41.10	3.52	3.43	41.60	3.73	3.26	42.00	3.97	3.10
	70	40.60	3.06	3.89	41.00	3.24	3.71	41.40	3.44	3.53
	80	40.00	2.69	4.35	40.40	2.85	4.16	40.90	3.03	3.96
40	60	37.50	3.30	3.33	37.80	3.48	3.19	38.10	3.67	3.05
	70	36.90	2.86	3.78	37.30	3.02	3.62	37.70	3.19	3.46
	80	36.30	2.51	4.24	36.80	2.65	4.06	37.30	2.81	3.88
30	60	–	–	–	–	–	–	–	–	–
	70	–	–	–	–	–	–	–	–	–
	80	–	–	–	–	–	–	–	–	–
17	60	–	–	–	–	–	–	–	–	–
	70	–	–	–	–	–	–	–	–	–
	80	–	–	–	–	–	–	–	–	–
10	60	–	–	–	–	–	–	–	–	–
	70	–	–	–	–	–	–	–	–	–
	80	–	–	–	–	–	–	–	–	–

NOTE: ALL CAPACITIES ARE NET, WITH INDOOR FAN HEAT ALREADY DEDUCTED. KW VALUES ARE FOR THE SYSTEM (OUTDOOR + INDOOR).

Multipliers for determining the performance with other indoor sections.

LOW CFM

Air Handler	Coil	MBH	COP	KW
–	FC/MC62	1.04	0.97	1.07
AHE60D	–	1.00	0.98	1.02
AHV60D	–	0.99	0.97	1.02
MV20D	FC/MC60D	1.00	0.96	1.05
MV20D	FC/MC62D	1.00	1.00	1.00
MV20D	FC64D	1.01	1.02	0.99

Continued on next page.

Furnace	Coil	MBH	COP	KW
T*(8,L)V*C16	FC/PC60C	1.00	0.90	1.11
T*(8,L)V*C20	FC/MC/PC60D	1.00	0.93	1.08
T*(8,L)V*C20	FC/MC62D	0.99	0.93	1.07
T*(8,L)V*C20	FC/PC60C	1.00	0.93	1.08
T*(8,L)V*C20	FC64D	1.01	0.98	1.04
T*(8,L)V*C20	UC60C	0.98	0.89	1.10
T*9V*C20	FC/MC/PC60D	1.00	0.91	1.09
T*9V*C20	FC/MC62D	1.00	0.94	1.07
T*9V*C20	FC/PC60C	1.00	0.91	1.09
T*9V*C20	FC64D	1.01	0.96	1.05
T*9V*C20	UC60C	0.99	0.90	1.10
T*9V*D20	FC/MC/PC60D	1.00	0.92	1.09
T*9V*D20	FC/MC62D	1.00	0.95	1.05
T*9V*D20	FC64D	1.01	0.98	1.03
T*9V*D20	UC60D	0.99	0.90	1.10
TM8X080C16MP11	FC/MC/PC60D	0.99	0.92	1.07
TM8X080C16MP11	FC/MC62D	0.99	0.94	1.05
TM8X080C16MP11	FC/PC60C	0.99	0.91	1.09
TM8X080C16MP11	FC64D	1.00	0.98	1.02
TM8X080C16MP11	UC60C	0.99	0.90	1.10
TM8X080C16MP11	UC60D	0.98	0.90	1.09
TM8X100C16MP11	FC/MC/PC60D	0.99	0.92	1.07
TM8X100C16MP11	FC/MC62D	0.99	0.94	1.05
TM8X100C16MP11	FC/PC60C	0.99	0.91	1.09
TM8X100C16MP11	FC64D	1.00	0.98	1.02
TM8X100C16MP11	UC60C	0.99	0.90	1.10
TM8X100C16MP11	UC60D	0.98	0.90	1.09
TM8X100C20MP11	FC/MC/PC60D	1.00	0.94	1.07
TM8X100C20MP11	FC/MC62D	0.99	0.96	1.03
TM8X100C20MP11	FC/PC60C	1.00	0.93	1.07
TM8X100C20MP11	UC60C	0.99	0.92	1.07
TM8X100C20MP11	UC60D	0.99	0.93	1.07
TM8X120C20MP11	FC/MC/PC60D	1.00	0.94	1.07
TM8X120C20MP11	FC/MC62D	0.99	0.96	1.03
TM8X120C20MP11	FC/PC60C	1.00	0.93	1.07
TM8X120C20MP11	UC60C	0.99	0.92	1.07
TM8X120C20MP11	UC60D	0.99	0.93	1.07
TMLX080C16MP11	FC/MC/PC60D	0.99	0.92	1.07

Furnace	Coil	MBH	COP	KW
TMLX080C16MP11	FC/MC62D	0.99	0.94	1.05
TMLX080C16MP11	FC/PC60C	0.99	0.91	1.09
TMLX080C16MP11	FC64D	1.00	0.98	1.02
TMLX080C16MP11	UC60C	0.99	0.90	1.10
TMLX080C16MP11	UC60D	0.98	0.90	1.09
TMLX100C16MP11	FC/MC/PC60D	0.99	0.92	1.07
TMLX100C16MP11	FC/MC62D	0.99	0.94	1.05
TMLX100C16MP11	FC/PC60C	0.99	0.91	1.09
TMLX100C16MP11	FC64D	1.00	0.98	1.02
TMLX100C16MP11	UC60C	0.99	0.90	1.10
TMLX100C16MP11	UC60D	0.98	0.90	1.09
TMLX100C20MP11	FC/MC/PC60D	1.00	0.94	1.07
TMLX100C20MP11	FC/MC62D	0.99	0.96	1.03
TMLX100C20MP11	FC/PC60C	1.00	0.93	1.07
TMLX100C20MP11	UC60C	0.99	0.92	1.07
TMLX100C20MP11	UC60D	0.99	0.93	1.07
TMLX120C20MP11	FC/MC/PC60D	1.00	0.94	1.07
TMLX120C20MP11	FC/MC62D	0.99	0.96	1.03
TMLX120C20MP11	FC/PC60C	1.00	0.93	1.07
TMLX120C20MP11	UC60C	0.99	0.92	1.07
TMLX120C20MP11	UC60D	0.99	0.93	1.07
TM9E100C20MP11	FC/MC/PC60D	0.99	0.89	1.11
TM9E100C20MP11	FC/MC62D	0.99	0.93	1.07
TM9E100C20MP11	FC64D	1.00	0.96	1.05
TM9E100C20MP11	UC60D	0.98	0.87	1.12
TM9E120D20MP11	FC/MC/PC60D	0.99	0.90	1.10
TM9E120D20MP11	FC/MC62D	0.99	0.93	1.07
TM9E120D20MP11	FC64D	1.00	0.94	1.06
TM9E120D20MP11	UC60D	0.98	0.90	1.09
TM9X100C20MP11	FC/MC/PC60D	0.99	0.89	1.11
TM9X100C20MP11	FC/MC62D	0.99	0.93	1.07
TM9X100C20MP11	FC64D	1.00	0.96	1.05
TM9X100C20MP11	UC60D	0.98	0.87	1.12
TM9X120D20MP11	FC/MC/PC60D	0.99	0.90	1.10
TM9X120D20MP11	FC/MC62D	0.99	0.93	1.07
TM9X120D20MP11	FC64D	1.00	0.94	1.06
TM9X120D20MP11	UC60D	0.98	0.90	1.09

HEATING PERFORMANCE DATA - HIGH CFM 2-STAGE OPERATION										
OUTDOOR UNIT MODEL NO.		HL8B060F4C								
INDOOR COIL MODEL NO.		FC/MC62D + MV20D								
AIR TEMP. ENTERING OUTDOOR UNIT (°F)	AIR TEMP. ENTERING INDOOR COIL (°F)	ID CFM								
		1550			1750			1950		
		MBH	COP	KW	MBH	COP	KW	MBH	COP	KW
60	60	68.5	4.69	4.28	69.5	4.86	4.19	70.4	5.04	4.10
	70	67.3	4.14	4.76	68.2	4.30	4.64	69.1	4.46	4.54
	80	66.2	3.70	5.25	67.0	3.84	5.10	67.7	4.00	4.97
47	60	58.5	4.13	4.15	58.9	4.26	4.06	59.4	4.39	3.97
	70	57.5	3.69	4.57	58.0	3.80	4.47	58.5	3.92	4.37
	80	56.5	3.31	5.00	57.0	3.41	4.90	57.6	3.52	4.79
40	60	53.1	3.81	4.08	53.2	3.90	4.00	53.3	4.00	3.91
	70	52.5	3.42	4.50	52.8	3.51	4.41	53.1	3.60	4.33
	80	52.0	3.10	4.92	52.5	3.18	4.83	53.0	3.27	4.74
30	60	50.3	3.84	3.84	48.8	3.89	3.68	47.3	3.95	3.52
	70	49.0	3.30	4.36	48.6	3.39	4.21	48.2	3.49	4.04
	80	47.8	2.87	4.88	48.4	3.00	4.72	49.0	3.14	4.57
17	60	39.3	3.05	3.78	40.4	3.18	3.73	41.6	3.30	3.70
	70	36.7	2.55	4.22	38.0	2.70	4.12	39.3	2.86	4.04
	80	34.1	2.14	4.67	35.6	2.31	4.52	37.0	2.48	4.38
10	60	36.4	2.91	3.66	36.4	2.95	3.61	36.5	3.00	3.57
	70	36.1	2.58	4.11	36.3	2.62	4.06	36.4	2.66	4.02
	80	35.9	2.30	4.56	36.1	2.35	4.51	36.4	2.39	4.46

NOTE: ALL CAPACITIES ARE NET, WITH INDOOR FAN HEAT ALREADY DEDUCTED. KW VALUES ARE FOR THE SYSTEM (OUTDOOR + INDOOR).

Multipliers for determining the performance with other indoor sections.

HIGH CFM

Air Handler	Coil	MBH	COP	KW
–	FC/MC62	1.01	0.96	1.05
AHE60D	–	1.00	0.99	1.01
AHV60D	–	0.99	0.96	1.03
MV20D	FC/MC60D	0.99	0.96	1.03
MV20D	FC/MC62D	1.00	1.00	1.00
MV20D	FC64D	1.01	1.02	0.99

Continued on next page.

Furnace	Coil	MBH	COP	KW
T*(8,L)V*C16	FC/PC60C	0.99	0.92	1.08
T*(8,L)V*C20	FC/MC/PC60D	0.98	0.93	1.06
T*(8,L)V*C20	FC/MC62D	0.99	0.94	1.05
T*(8,L)V*C20	FC/PC60C	0.98	0.93	1.06
T*(8,L)V*C20	FC64D	1.02	1.01	1.01
T*(8,L)V*C20	UC60C	0.98	0.93	1.06
T*9V*C20	FC/MC/PC60D	0.99	0.92	1.08
T*9V*C20	FC/MC62D	1.00	0.95	1.05
T*9V*C20	FC/PC60C	0.99	0.92	1.08
T*9V*C20	FC64D	1.00	0.98	1.02
T*9V*C20	UC60C	0.99	0.92	1.08
T*9V*D20	FC/MC/PC60D	0.98	0.92	1.07
T*9V*D20	FC/MC62D	0.99	0.95	1.04
T*9V*D20	FC64D	1.00	0.98	1.02
T*9V*D20	UC60D	0.98	0.92	1.07
TM8X080C16MP11	FC/MC/PC60D	0.98	0.91	1.09
TM8X080C16MP11	FC/MC62D	0.99	0.94	1.06
TM8X080C16MP11	FC/PC60C	0.98	0.90	1.09
TM8X080C16MP11	FC64D	0.99	0.96	1.03
TM8X080C16MP11	UC60C	0.98	0.89	1.10
TM8X080C16MP11	UC60D	0.98	0.90	1.09
TM8X100C16MP11	FC/MC/PC60D	0.98	0.91	1.09
TM8X100C16MP11	FC/MC62D	0.99	0.94	1.06
TM8X100C16MP11	FC/PC60C	0.98	0.90	1.09
TM8X100C16MP11	FC64D	0.99	0.96	1.03
TM8X100C16MP11	UC60C	0.98	0.89	1.10
TM8X100C16MP11	UC60D	0.98	0.90	1.09
TM8X100C20MP11	FC/MC/PC60D	0.98	0.92	1.07
TM8X100C20MP11	FC/MC62D	0.99	0.95	1.05
TM8X100C20MP11	FC/PC60C	0.98	0.91	1.08
TM8X100C20MP11	UC60C	0.98	0.91	1.08
TM8X100C20MP11	UC60D	0.98	0.92	1.07
TM8X120C20MP11	FC/MC/PC60D	0.98	0.92	1.07
TM8X120C20MP11	FC/MC62D	0.99	0.95	1.05
TM8X120C20MP11	FC/PC60C	0.98	0.91	1.08
TM8X120C20MP11	UC60C	0.98	0.91	1.08
TM8X120C20MP11	UC60D	0.98	0.92	1.07
TMLX080C16MP11	FC/MC/PC60D	0.98	0.91	1.09

Furnace	Coil	MBH	COP	KW
TMLX080C16MP11	FC/MC62D	0.99	0.94	1.06
TMLX080C16MP11	FC/PC60C	0.98	0.90	1.09
TMLX080C16MP11	FC64D	0.99	0.96	1.03
TMLX080C16MP11	UC60C	0.98	0.89	1.10
TMLX080C16MP11	UC60D	0.98	0.90	1.09
TMLX100C16MP11	FC/MC/PC60D	0.98	0.91	1.09
TMLX100C16MP11	FC/MC62D	0.99	0.94	1.06
TMLX100C16MP11	FC/PC60C	0.98	0.90	1.09
TMLX100C16MP11	FC64D	0.99	0.96	1.03
TMLX100C16MP11	UC60C	0.98	0.89	1.10
TMLX100C16MP11	UC60D	0.98	0.90	1.09
TMLX100C20MP11	FC/MC/PC60D	0.98	0.92	1.07
TMLX100C20MP11	FC/MC62D	0.99	0.95	1.05
TMLX100C20MP11	FC/PC60C	0.98	0.91	1.08
TMLX100C20MP11	UC60C	0.98	0.91	1.08
TMLX100C20MP11	UC60D	0.98	0.92	1.07
TMLX120C20MP11	FC/MC/PC60D	0.98	0.92	1.07
TMLX120C20MP11	FC/MC62D	0.99	0.95	1.05
TMLX120C20MP11	FC/PC60C	0.98	0.91	1.08
TMLX120C20MP11	UC60C	0.98	0.91	1.08
TMLX120C20MP11	UC60D	0.98	0.92	1.07
TM9E100C20MP11	FC/MC/PC60D	0.98	0.90	1.09
TM9E100C20MP11	FC/MC62D	0.99	0.94	1.06
TM9E100C20MP11	FC64D	0.99	0.96	1.03
TM9E100C20MP11	UC60D	0.98	0.90	1.09
TM9E120D20MP11	FC/MC/PC60D	0.98	0.91	1.08
TM9E120D20MP11	FC/MC62D	0.99	0.94	1.05
TM9E120D20MP11	FC64D	0.99	0.96	1.03
TM9E120D20MP11	UC60D	0.98	0.90	1.09
TM9X100C20MP11	FC/MC/PC60D	0.98	0.90	1.09
TM9X100C20MP11	FC/MC62D	0.99	0.94	1.06
TM9X100C20MP11	FC64D	0.99	0.96	1.03
TM9X100C20MP11	UC60D	0.98	0.90	1.09
TM9X120D20MP11	FC/MC/PC60D	0.98	0.91	1.08
TM9X120D20MP11	FC/MC62D	0.99	0.94	1.05
TM9X120D20MP11	FC64D	0.99	0.96	1.03
TM9X120D20MP11	UC60D	0.98	0.90	1.09

NOTES