

# INSTALLATION INSTRUCTIONS FOR LIGHT COMMERCIAL SELF-CONTAINED PACKAGED HEATING & COOLING UNIT 7.5 TON - 12.5 TON CPC/CPH SERIES

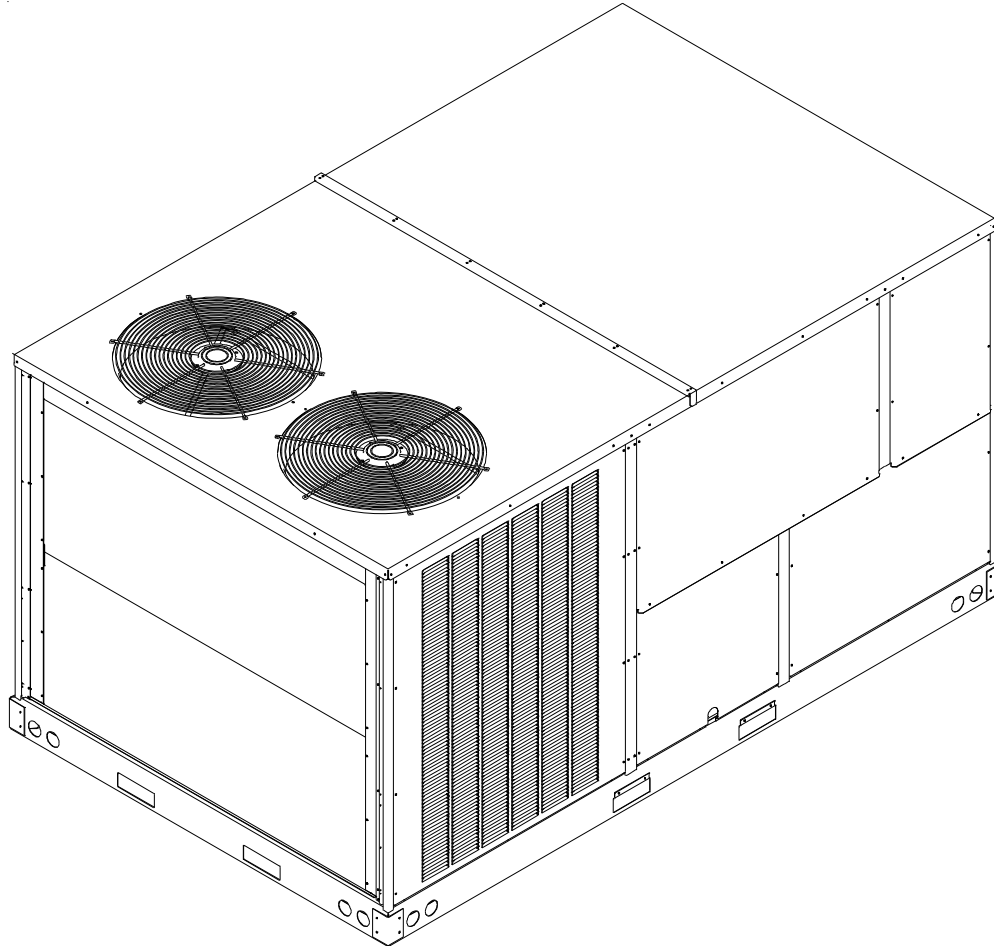

**RECOGNIZE THIS SYMBOL AS A SAFETY PRECAUTION.**

## ATTENTION INSTALLING PERSONNEL

Prior to installation, thoroughly familiarize yourself with this Installation Manual. Observe all safety warnings.  
During installation or repair, caution is to be observed.

It is your responsibility to install the product safely and to educate the customer on its safe use.

All information contained herein is subject to change without notice.

These installation instructions cover the **outdoor** installation of single package electric heating and cooling units. See the Specification Sheet applicable to your model\* for information regarding accessories.

**\*NOTE:** Please contact your distributor or our website for the applicable Specification Sheets referred to in this manual.

Goodman Manufacturing Company, L.P.  
5151 San Felipe, Suite 500  
Houston, TX 77056

[www.goodmanmfg.com](http://www.goodmanmfg.com)

[www.amana-hac.com](http://www.amana-hac.com)



## Index

Replacement Parts .....	2
Safety Instructions .....	2
General Information .....	3
Unit Location .....	4
Clearances .....	5
Roof Curb Post-Installation Checks .....	6
Roof Top Duct Connections .....	6
Rigging Details .....	6
Electrical Wiring .....	8
Circulating Air and Filters .....	10
Venting .....	10
Condensate Drain Connection .....	10
Startup, Adjustments, and Checks .....	10
Heat Pump Operation .....	13
Air flow Adjustments .....	14
Motor Sheave Adjustments .....	15
Maintenance .....	15
Service .....	16
Appendix A Blower Performance Data .....	16
Belt Drive - Standard .....	16 - 17
Belt Drive - High Static .....	18
Appendix B Electrical Data .....	19
Appendix C Unit Dimensions .....	20

### WARNING

THIS PRODUCT CONTAINS OR PRODUCES A CHEMICAL OR CHEMICALS WHICH MAY CAUSE SERIOUS ILLNESS OR DEATH AND WHICH ARE KNOWN TO THE STATE OF CALIFORNIA TO CAUSE CANCER, BIRTH DEFECTS OR OTHER REPRODUCTIVE HARM.

### WARNING

TO AVOID PROPERTY DAMAGE, PERSONAL INJURY OR DEATH, DO NOT USE THIS UNIT IF ANY PART HAS BEEN UNDER WATER. IMMEDIATELY CALL A QUALIFIED SERVICE TECHNICIAN TO INSPECT THE FURNACE AND TO REPLACE ANY PART OF THE CONTROL SYSTEM AND ANY GAS CONTROL HAVING BEEN UNDER WATER.

## REPLACEMENT PARTS

### ORDERING PARTS

When reporting shortages or damages, or ordering repair parts, give the complete unit model and serial numbers as stamped on the unit's nameplate.

Replacement parts for this appliance are available through your contractor or local distributor. For the location of your nearest distributor, consult the white business pages, the yellow page section of the local telephone book or contact:

CONSUMER AFFAIRS  
GOODMAN MANUFACTURING COMPANY, L.P.  
7401 SECURITY WAY  
HOUSTON, TEXAS 77040  
877-254-4729

## SAFETY INSTRUCTIONS

### TO THE INSTALLER

Before installing this unit, please read this manual to familiarize yourself on the specific items which must be adhered to, including maximum external static pressure to unit, air temperature rise, minimum or maximum CFM and motor speed connections.

Keep this literature in a safe place for future reference.

### CAUTION

SHEET METAL PARTS, SCREWS, CLIPS AND SIMILAR ITEMS INHERENTLY HAVE SHARP EDGES, AND IT IS NECESSARY THAT THE INSTALLER AND SERVICE PERSONNEL EXERCISE CAUTION.

### WARNING

DO NOT CONNECT TO OR USE ANY DEVICE THAT IS NOT DESIGN CERTIFIED BY GOODMAN FOR USE WITH THIS UNIT. SERIOUS PROPERTY DAMAGE, PERSONAL INJURY, REDUCED UNIT PERFORMANCE AND/OR HAZARDOUS CONDITIONS MAY RESULT FROM THE USE OF SUCH NON-APPROVED DEVICES.

### WARNING

THIS UNIT MUST NOT BE USED AS A "CONSTRUCTION HEATER" DURING THE FINISHING PHASES OF CONSTRUCTION ON A NEW STRUCTURE. THIS TYPE OF USE MAY RESULT IN PREMATURE FAILURE OF THE UNIT DUE TO EXTREMELY LOW RETURN AIR TEMPERATURES AND EXPOSURE TO CORROSIVE OR VERY DIRTY ATMOSPHERES.

### WARNING

**HIGH VOLTAGE!**  
DISCONNECT ALL POWER BEFORE SERVICING OR INSTALLING THIS UNIT. MULTIPLE POWER SOURCES MAY BE PRESENT. FAILURE TO DO SO MAY CAUSE PROPERTY DAMAGE, PERSONAL INJURY OR DEATH.





## WARNING

TO PREVENT THE RISK OF PROPERTY DAMAGE, PERSONAL INJURY, OR DEATH, DO NOT STORE COMBUSTIBLE MATERIALS OR USE GASOLINE OR OTHER FLAMMABLE LIQUIDS OR VAPORS IN THE VICINITY OF THIS APPLIANCE.



## WARNING

**ONLY** INDIVIDUALS MEETING (AT A MINIMUM) THE REQUIREMENTS OF AN "ENTRY LEVEL TECHNICIAN" AS SPECIFIED BY THE AIR CONDITIONING, HEATING, AND REFRIGERATION INSTITUTE (AHRI) MAY USE THIS INFORMATION. ATTEMPTING TO INSTALL OR REPAIR THIS UNIT WITHOUT SUCH BACKGROUND MAY RESULT IN PRODUCT DAMAGE, PERSONAL INJURY OR DEATH.

## GENERAL INFORMATION



## WARNING

TO PREVENT PROPERTY DAMAGE, PERSONAL INJURY OR DEATH, DUE TO FIRE, EXPLOSIONS, SMOKE, SOOT, CONDENSATION, ELECTRIC SHOCK OR CARBON MONOXIDE, THIS UNIT MUST BE PROPERLY INSTALLED, REPAIRED, OPERATED, AND MAINTAINED.

*This unit is approved for outdoor installation ONLY.* To assure that your unit operates safely and efficiently, it must be installed, operated, and maintained in accordance with these installation and operating instructions, all local building codes and ordinances.

## EPA REGULATIONS

**IMPORTANT: THE UNITED STATES ENVIRONMENTAL PROTECTION AGENCY (EPA) HAS ISSUED VARIOUS REGULATIONS REGARDING THE INTRODUCTION AND DISPOSAL OF REFRIGERANTS IN THIS UNIT. FAILURE TO FOLLOW THESE REGULATIONS MAY HARM THE ENVIRONMENT AND CAN LEAD TO THE IMPOSITION OF SUBSTANTIAL FINES. BECAUSE REGULATIONS MAY VARY DUE TO PASSAGE OF NEW LAWS, WE SUGGEST A CERTIFIED TECHNICIAN PERFORM ANY WORK DONE ON THIS UNIT. SHOULD YOU HAVE ANY QUESTIONS PLEASE CONTACT THE LOCAL OFFICE OF THE EPA.**

## NATIONAL CODES

This product is designed and manufactured to permit installation in accordance with National Codes. It is the installer's responsibility to install the product in accordance with National Codes and/or prevailing local codes and regulations.

The heating and cooling capacities of the unit should be greater than or equal to the design heating and cooling loads of the area to be conditioned. The loads should be calculated by an approved method or in accordance with ASHRAE Guide or Manual J - Load Calculations published by the Air Conditioning Contractors of America.

Obtain from:

American National Standards Institute  
1430 Broadway  
New York, NY 10018

System design and installation should also, where applicable, follow information presented in accepted industry guides such as the ASHRAE Handbooks. The manufacturer assumes no responsibility for equipment installed in violation of any code or regulation. The mechanical installation of the packaged roof top units consists of making final connections between the unit and building services; supply and return duct connections; and drain connections (if required). The internal systems of the unit are completely factory-installed and tested prior to shipment.

Units are generally installed on a steel roof mounting curb assembly which has been shipped to the job site for installation on the roof structure prior to the arrival of the unit. The model number shown on the unit's identification plate identifies the various components of the unit such as refrigeration tonnage, heating input and voltage.

Carefully inspect the unit for damage. Any bolts or screws which may have loosened in transit must be re-tightened. In the event of damage, the receiver should:

1. Make notation on delivery receipt of any visible damage to shipment or container.
2. Notify carrier promptly and request an inspection.
3. In case of concealed damage, carrier should be notified as soon as possible-preferably within 5 days.
4. File the claim with the following supporting documents:
  - a. Original Bill of Lading, certified copy, or indemnity bond.
  - b. Original paid freight bill or indemnity in lieu thereof.
  - c. Original invoice or certified copy thereof, showing trade and other discounts or reductions.
  - d. Copy of the inspection report issued by carrier representative at the time damage is reported to the carrier. The carrier is responsible for making prompt inspection of damage and for a thorough investigation of each claim. The distributor or manufacturer will not accept claims from dealers for transportation damage.

**NOTE:** When inspecting the unit for transportation damage, remove all packaging materials. Recycle or dispose of the packaging material according to local codes.

## PRE-INSTALLATION CHECKS

Carefully read all instructions for the installation prior to installing unit. Ensure each step or procedure is understood and any special considerations are taken into account before starting installation. Assemble all tools, hardware and supplies needed to complete the installation. Some items may need to be purchased locally.

## UNIT LOCATION



### WARNING

**TO PREVENT POSSIBLE EQUIPMENT DAMAGE, PROPERTY DAMAGE, PERSONAL INJURY OR DEATH, THE FOLLOWING BULLET POINTS MUST BE OBSERVED WHEN INSTALLING THE UNIT.**

**IMPORTANT NOTE:** Remove wood shipping rails and metal shipping brace (if applicable) prior to installation of the unit on a roof curb.

#### ALL INSTALLATIONS:

**IMPORTANT NOTE:** If a crankcase heater is used, the unit should be energized 24 hours prior to compressor start up to ensure crankcase heater has sufficiently warmed the compressor. Compressor damage may occur if this step is not followed.

**NOTE:** Appliance is shipped from factory for vertical duct application.

Proper installation of the unit ensures trouble-free operation. Improper installation can result in problems ranging from noisy operation to property or equipment damages, dangerous conditions that could result in injury or personal property damage and could void the warranty. Give this booklet to the user and explain it's provisions. The user should retain these instructions for future reference.

- For proper operation and condensate drainage, the unit must be mounted level.
- The flue outlet hood must be at least three feet above any forced air inlet located within ten feet. The economizer/manual fresh air intake/motorized fresh air intake and combustion air inlet mounted on the unit are not affected by this restriction.
- Do not locate the unit in an area where the outdoor air (i.e. combustion air for the unit) will be frequently contaminated by compounds containing chlorine or fluorine. Common sources of such compounds include swimming pool chemicals and chlorine bleaches, paint stripper, adhesives, paints, varnishes, sealers, waxes (which are not yet dried) and solvents used during construction and remodeling. Various commercial and industrial processes may also be sources of chlorine/fluorine compounds.
- To avoid possible illness or death of the building occupants, do NOT locate outside air intake device (economizer, manual fresh air intake, motorized fresh air intake) too close to an exhaust outlet, gas vent termination, or plumbing vent outlet. For specific distances required, consult local codes.
- Allow minimum clearances from the enclosure for fire protection, proper operation, and service access (see Unit Clearances). These clearances must be permanently maintained.
- When the unit is heating, the temperature of the return air entering the unit must be between 50°F and 100°F.

#### GROUND LEVEL INSTALLATIONS ONLY:

- When the unit is installed on the ground adjacent to the building, a level concrete (or equal) base is recommended. Prepare a base that is 3" larger than the package unit footprint and a minimum of 3" thick.
- The base should also be located where no runoff of water from higher ground can collect in the unit.

#### ROOF TOP INSTALLATIONS ONLY:

- To avoid possible property damage or personal injury, the roof must have sufficient structural strength to carry the weight of the unit(s) and snow or water loads as required by local codes. Consult a structural engineer to determine the weight capabilities of the roof.
- The unit may be installed directly on wood floors or on Class A, Class B, or Class C roof covering material.
- To avoid possible personal injury, a safe, flat surface for service personnel should be provided.
- As indicated on the unit's data plate, a minimum clearance of 36" to any combustible material is required on the access side of the unit. All combustible materials must be kept out of this area.
- This 36" clearance must also be maintained to insure proper combustion air flow. The combustion air intake must not be blocked for any reason, including blockage by snow.
- Adequate clearances from the unit to any adjacent public walkways, adjacent buildings, building openings or openable windows must be maintained in accordance with National Codes.

#### UNIT PRECAUTIONS

- Do not stand or walk on the unit.
- Except for holes in the wiring entrances (see Figure below), do not drill holes anywhere in panels or in the base frame of the unit. Unit access panels provide structural support.

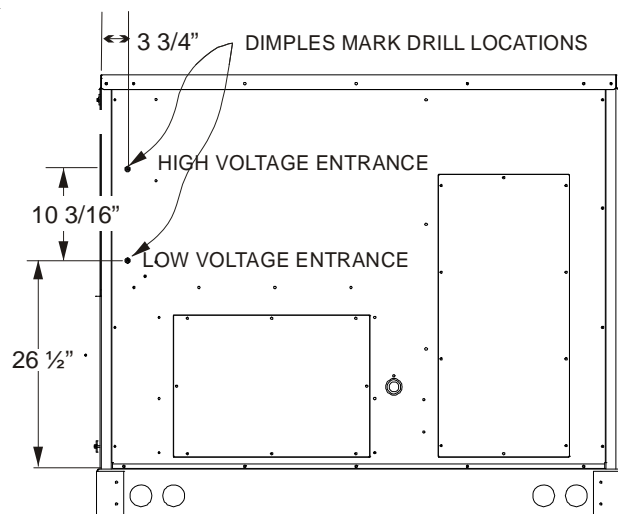

**ELECTRICAL ENTRANCE LOCATIONS**

- Do not remove any access panels until unit has been installed on roof curb or field supplied structure.
- Do not roll unit across finished roof without prior approval of owner or architect.
- Do not skid or slide on any surface as this may damage unit base. The unit must be stored on a flat, level surface. Protect the condenser coil because it is easily damaged.

### ROOF CURB INSTALLATIONS ONLY:

Curb installations must comply with local codes and should be done in accordance with the established guidelines of the National Roofing Contractors Association.

Proper unit installation requires that the roof curb be firmly and permanently attached to the roof structure. Check for adequate fastening method prior to setting the unit on the curb.

Full perimeter roof curbs are available from the factory and are shipped unassembled. Field assembly, squaring, leveling and mounting on the roof structure are the responsibility of the installing contractor. All required hardware necessary for the assembly of the sheet metal curb is included in the curb accessory.



### WARNING

**TO PREVENT POSSIBLE EQUIPMENT DAMAGE, PROPERTY DAMAGE, PERSONAL INJURY OR DEATH, THE FOLLOWING BULLET POINTS MUST BE OBSERVED WHEN INSTALLING THE UNIT.**

- Sufficient structural support must be determined prior to locating and mounting the curb and package unit.
- Ductwork must be constructed using industry guidelines. The duct work must be placed into the roof curb before mounting the package unit. Our full perimeter curbs include duct connection frames to be assembled with the curb. Cantilevered type curbs are not available from the factory.
- Curb insulation, cant strips, flashing and general roofing material are furnished by the contractor.

The curbs must be supported on parallel sides by roof members. The roof members must not penetrate supply and return duct opening areas as damage to the unit might occur.

**NOTE:** The unit and curb accessories are designed to allow vertical duct installation before unit placement. Duct installation after unit placement is not recommended.



### CAUTION

**ALL CURBS LOOK SIMILAR. TO AVOID INCORRECT CURB POSITIONING, CHECK JOB PLANS CAREFULLY AND VERIFY MARKINGS ON CURB ASSEMBLY. INSTRUCTIONS MAY VARY IN CURB STYLES AND SUPERSEDES INFORMATION SHOWN.**

See the manual shipped with the roof curb for assembly and installation instructions.

### CLEARANCES

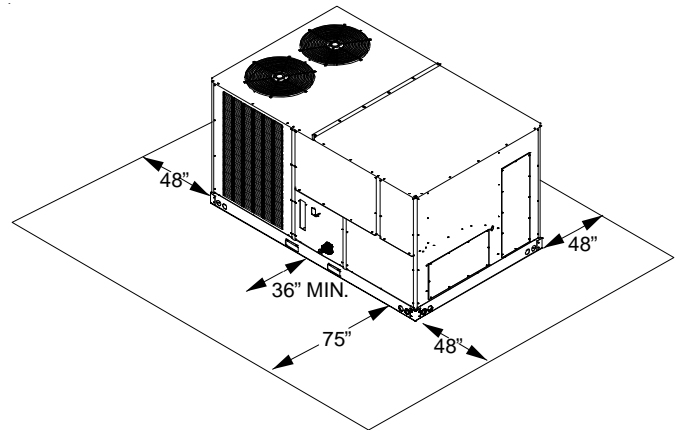

### UNIT CLEARANCES

Adequate clearance around the unit should be kept for safety, service, maintenance, and proper unit operation. A total clearance of 75" on the main control panel side of the unit is recommended to facilitate possible fan shaft, coil, electric heat and gas furnace removal. A clearance of 48" is recommended on all other sides of the unit to facilitate possible compressor removal, to allow service access and to insure proper ventilation and condenser airflow. The unit must not be installed beneath any obstruction. The unit should be installed remote from all building exhausts to inhibit ingestion of exhaust air into the unit fresh air intake.

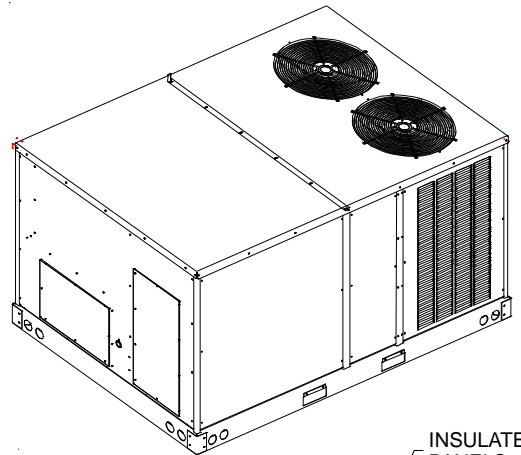

INSULATED PANELS

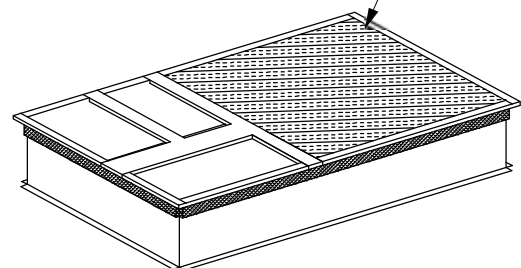

Roof Curb Installation

## ROOF CURB POST-INSTALLATION CHECKS

After installation, check the top of the curb, duct connection frame and duct flanges to make sure gasket has been applied properly. Gasket should be firmly applied to the top of the curb perimeter, duct flanges and any exposed duct connection frame. If gasket is loose, re-apply using strong weather resistant adhesive.

### PROTRUSION

Inspect curb to ensure that none of the utility services (electric) routed through the curb protrude above the curb.



**CAUTION**

IF PROTRUSIONS EXIST, DO NOT ATTEMPT TO SET UNIT ON CURB.

## ROOF TOP DUCT CONNECTIONS

Install all duct connections on the unit before placing the unit on rooftop.

### HORIZONTAL DISCHARGE

For horizontal discharge, remove the supply and return duct covers and place them over the vertical discharge return and supply openings. Install with insulation facing up, using the longer screws provided in the literature package.

Ensure that the top of the duct connection frame is flush with the top of the roof curb.

Flexible duct connectors between the unit and ducts are recommended. Insulate and weatherproof all external ductwork and joints as required and in accordance with local codes.

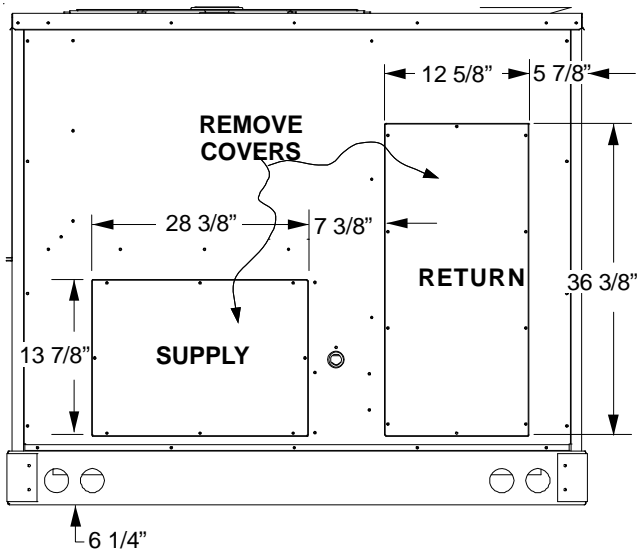

HORIZONTAL DISCHARGE DUCT CONNECTIONS

## RIGGING DETAILS



**WARNING**

TO PREVENT PROPERTY DAMAGE, THE UNIT SHOULD REMAIN IN AN UPRIGHT POSITION DURING ALL RIGGING AND MOVING OPERATIONS. TO FACILITATE LIFTING AND MOVING WHEN A CRANE IS USED, PLACE THE UNIT IN AN ADEQUATE CABLE SLING.



**CAUTION**

DO NOT LIFT UNITS TWO AT A TIME. PROVISIONS FOR FORKS HAVE BEEN INCLUDED IN THE UNIT BASE FRAME. MINIMUM FORK LENGTH IS 48" TO PREVENT DAMAGE TO THE UNIT.

Provisions for forks have been included in the unit base frame. No other fork locations are approved.



**WARNING**

TO PREVENT POSSIBLE EQUIPMENT DAMAGE, PROPERTY DAMAGE, PERSONAL INJURY OR DEATH, THE FOLLOWING BULLET POINTS MUST BE OBSERVED WHEN INSTALLING THE UNIT.

- Unit must be lifted by the four lifting holes located at the base frame corners.
- Lifting cables should be attached to the unit with shackles.
- The distance between the crane hook and the top of the unit must not be less than 60".
- Two spreader bars must span over the unit to prevent damage to the cabinet by the lift cables. Spreader bars must be of sufficient length so that cables do not come in contact with the unit during transport. Remove wood struts mounted beneath unit base frame before setting unit on roof curb. These struts are intended to protect unit base frame from fork lift damage. Removal is accomplished by extracting the sheet metal retainers and pulling the struts through the base of the unit. Refer to rigging label on the unit.
- Your unit may be equipped with a steel shipping brace located underneath the unit (under compressors). If installing on a roof curb, the brace **MUST** be removed. Follow the following instructions for removal.



**CAUTION**

WHEN UNIT IS SUSPENDED, BOARDS AND SHIPPING BRACE WILL DROP WHEN SCREWS ARE REMOVED. TO PREVENT PERSONAL INJURY, STAND CLEAR. REMOVE FORK HOLE BRACKETS, BOARDS AND SHIPPING BRACE FROM BOTTOM OF UNIT BEFORE PLACING UNIT ONTO CURB.

### Before installing this unit on a roof curb:

1. Remove wooden struts per installation instructions. *These are the struts that are located in the fork holes and are used to protect the unit from damage while lifting with forks.*
2. Locate and remove the twelve (12) screws that attach the shipping brace to the side rails. There will be six (6) screws on each side of the unit and they are in a diagonal pattern. *See following figure.*

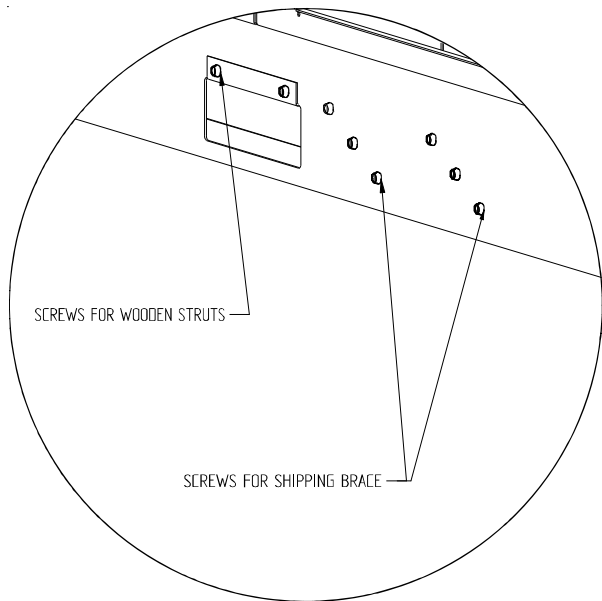

To assist in determining rigging requirements, unit weights are shown as follows:

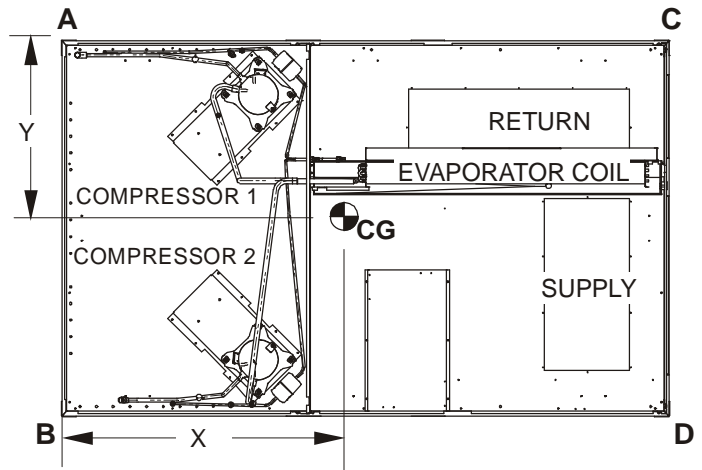

CORNER & CENTER OF GRAVITY LOCATIONS

3. Lift unit per the "Rigging Details" section of the installation instructions, observing all warnings and cautions. Lift the unit high enough off the ground to reach under and grasp the shipping brace.
4. Rotate the brace by tapping the ends until the brace falls free from the unit.
5. Dispose of the brace appropriately.

**Important:** If using bottom discharge with roof curb, ductwork should be attached to the curb prior to installing the unit. Ductwork dimensions are shown in Roof Curb Installation Instructions.

Refer to the Roof Curb Installation Instructions for proper curb installation. Curbing must be installed in compliance with the National Roofing Contractors Association Manual.

Lower unit carefully onto roof mounting curb. While rigging unit, center of gravity will cause condenser end to be lower than supply air end.

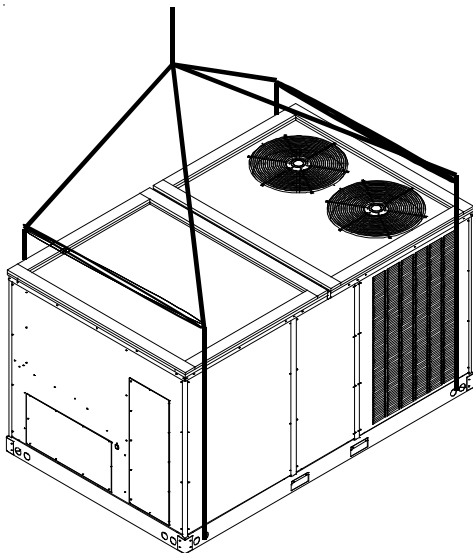

DATA	CPC Weights (lbs)		
	090/102	120	150
Corner Weight - A	260	285	420
Corner Weight - B	245	285	335
Corner Weight - C	240	285	290
Corner Weight - D	225	285	230
Unit Shipping Weight	1000	1175	1300
Unit Operating Weight	975	1135	1275
X (Inches)	48	48	41
Y (Inches)	30	30	27.5

DATA	CPH Weights (lbs)		
	090	102/120	150
Corner Weight - A	285	345	435
Corner Weight - B	285	325	345
Corner Weight - C	285	320	300
Corner Weight - D	285	300	240
Unit Shipping Weight	1175	1310	1350
Unit Operating Weight	1135	1285	1325
X (Inches)	48	48	41
Y (Inches)	30	30	27.5

**NOTE:** These weights are without accessories installed.



**TO PREVENT SEVERE DAMAGE TO THE BOTTOM OF THE UNIT, DO NOT FORK LIFT UNIT AFTER WOOD STRUTS HAVE BEEN REMOVED.**

Bring condenser end of unit into alignment with the curb. With condenser end of the unit resting on curb member and using curb as a fulcrum, lower opposite end of the unit until entire unit is seated on the curb. When a rectangular cantilever curb is used, care should be taken to center the unit. Check for proper alignment and orientation of supply and return openings with duct.

## RIGGING REMOVAL



### CAUTION

TO PREVENT DAMAGE TO THE UNIT, DO NOT ALLOW CRANE HOOKS AND SPREADER BARS TO REST ON THE ROOF OF THE UNIT.

Remove spreader bars, lifting cables and other rigging equipment.

## ELECTRICAL WIRING



### WARNING

**HIGH VOLTAGE!**  
DISCONNECT ALL POWER BEFORE SERVICING OR INSTALLING THIS UNIT. MULTIPLE POWER SOURCES MAY BE PRESENT. FAILURE TO DO SO MAY CAUSE PROPERTY DAMAGE, PERSONAL INJURY OR DEATH.



### WARNING

**HIGH VOLTAGE!**  
TO AVOID PERSONAL INJURY OR DEATH DUE TO ELECTRICAL SHOCK, DO NOT TAMPER WITH FACTORY WIRING. THE INTERNAL POWER AND CONTROL WIRING OF THESE UNITS ARE FACTORY-INSTALLED AND HAVE BEEN THOROUGHLY TESTED PRIOR TO SHIPMENT. CONTACT YOUR LOCAL REPRESENTATIVE IF ASSISTANCE IS REQUIRED.



### CAUTION

TO PREVENT DAMAGE TO THE WIRING, PROTECT WIRING FROM SHARP EDGES. FOLLOW NATIONAL ELECTRICAL CODE AND ALL LOCAL CODES AND ORDINANCES. DO NOT ROUTE WIRES THROUGH REMOVABLE ACCESS PANELS.



### CAUTION

CONDUIT AND FITTINGS MUST BE WEATHER-TIGHT TO PREVENT WATER ENTRY INTO THE BUILDING.

For unit protection, use a fuse or HACR circuit breaker that is in excess of the circuit ampacity, but less than or equal to the maximum overcurrent protection device. DO NOT EXCEED THE MAXIMUM OVERCURRENT DEVICE SIZE SHOWN ON UNIT DATA PLATE.

All line voltage connections must be made through weather-proof fittings. All exterior power supply and ground wiring must be in approved weatherproof conduit.

The main power supply wiring to the unit and low voltage wiring to accessory controls must be done in accordance with these instructions, the latest edition of the National Electrical Code (ANSI/NFPA 70), and all local codes and ordinances. All field wiring shall conform with the temperature limitations for Type T wire (63°F/35°C rise).

The main power supply shall be three-phase, three wire. The unit is factory wired for the voltage shown on the unit's data plate.

**NOTE:** If supply voltage is 208V, all leads on primary of transformer TRANS1 must be moved from the 230V to the 208V tap.

Main power wiring should be sized for the minimum wire ampacity shown on the unit's data plate. Size wires in accordance with the ampacity tables in Article 310 of the National Electrical Code. If long wires are required, it may be necessary to increase the wire size to prevent excessive voltage drop. Wires should be sized for a maximum of 3% voltage drop.



### CAUTION

TO AVOID PROPERTY DAMAGE OR PERSONAL INJURY DUE TO FIRE, USE ONLY COPPER CONDUCTORS.



### CAUTION

LABEL ALL WIRES PRIOR TO DISCONNECTION WHEN SERVICING CONTROLS. WIRING ERRORS CAN CAUSE IMPROPER AND DANGEROUS OPERATION. VERIFY PROPER OPERATION AFTER SERVICING.

**NOTE:** A weather-tight disconnect switch, properly sized for the unit total load, must be field installed. An external field supplied disconnect may be mounted on the exterior panel.

Ensure the data plate is not covered by the field-supplied disconnect switch.

- Some disconnect switches are not fused. Protect the power leads at the point of distribution in accordance with the unit's data plate.
- The unit must be electrically grounded in accordance with local codes or, in the absence of local codes, with the latest edition of the National Electrical Code (ANSI-NFPA 70). A ground lug is provided for this purpose. Size grounding conductor in accordance with Table 250-95 of the National Electrical Code. Do not use the ground lug for connecting a neutral conductor.
- Connect power wiring to the Single Point Power block. This terminal block is located within the main control box.



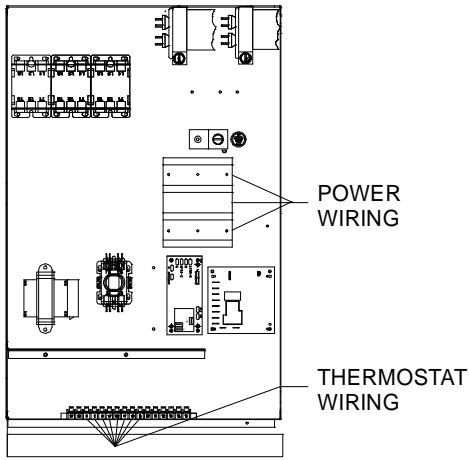

**POWER AND LOW VOLTAGE BLOCK LOCATIONS**

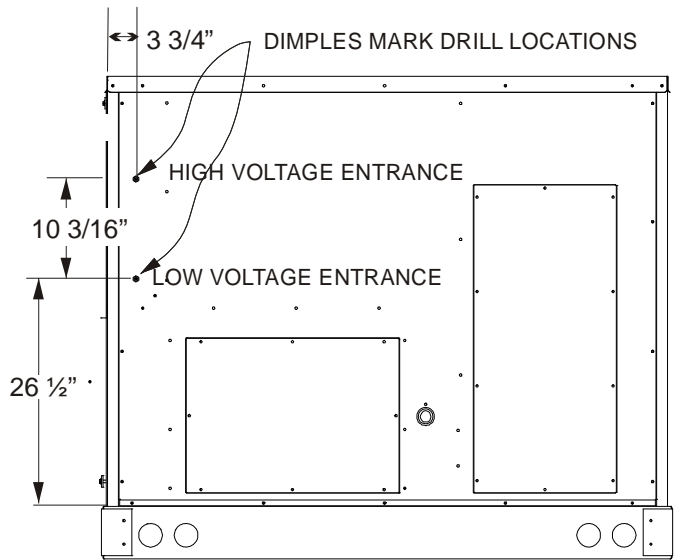

**ELECTRICAL ENTRANCE LOCATIONS**

Unit is equipped with Single Point Power Block and Low Voltage Block.

**LOW VOLTAGE CONTROL WIRING**

1. A 24V thermostat must be installed for unit operation. It may be purchased with the unit or field -supplied. Thermostats may be programmable or electromechanical as required.
2. Locate thermostat or remote sensor in the conditioned space where it will sense average temperature. Do not locate the device where it may be directly exposed to supply air, sunlight or other sources of heat. Follow installation instructions packaged with the thermostat.
3. Use #18 AWG wire for 24V control wiring runs not exceeding 75 feet. Use #16 AWG wire for 24V control wiring runs not exceeding 125 feet. Use #14 AWG wire for 24V control wiring runs not exceeding 200 feet. Low voltage wiring may be National Electrical Code (NEC) Class 2 where permitted by local codes.
4. Route thermostat wires from sub-base terminals to the unit. Control wiring should enter through the duct panel (dimple marks entrance location). Connect thermostat and any accessory wiring to low voltage terminal block TB1 in the main control box.

**NOTE:** Field-supplied conduit may need to be installed depending on unit/curb configuration. Use #18 AWG solid conductor wire whenever connecting thermostat wires to terminals on sub-base. DO NOT use larger than #18 AWG wire. A transition to #18 AWG wire may be required before entering thermostat sub-base.

**WARNING**

**FAILURE OF UNIT DUE TO OPERATION ON IMPROPER LINE VOLTAGE OR WITH EXCESSIVE PHASE UNBALANCE CONSTITUTES PRODUCT ABUSE AND WILL VOID YOUR WARRANTY AND MAY CAUSE SEVERE DAMAGE TO THE UNIT ELECTRICAL COMPONENTS.**

*Areas Without Convenience Outlet*

It is recommended that an independent 115V power source be brought to the vicinity of the roof top unit for portable lights and tools used by the service mechanic.

**UNITS INSTALLED ON ROOF TOPS**

Main power and low voltage wiring may enter the unit through the side or through the roof curb. Install conduit connectors at the desired entrance locations. External connectors must be weatherproof. All holes in the unit base must be sealed (including those around conduit nuts) to prevent water leakage into building. All required conduit and fittings are to be field supplied.

Supply voltage to roof top unit must not vary by more than 10% of the value indicated on the unit's data plate. Phase voltage unbalance must not exceed 2%. Contact your local power company for correction of improper voltage or phase unbalance.

TERMINAL	THERMOSTAT
Red	R (24V)
Green	G (Fan)
Orange	O (Rev. Valve)
White	W1 (Heat, 2nd)*
Yellow	Y1 (Low Cool)
Purple	Y2 (High Cool)
C (Blue)	C (Common)

\*Optional field installed heat connections  
CPC/H 090 THROUGH 150

## CIRCULATING AIR AND FILTERS

### DUCTWORK

The supply duct from the unit through a wall may be installed without clearance. However, minimum unit clearances must be maintained (see "Clearances" section). The supply duct should be provided with an access panel large enough to inspect the air chamber downstream of the heat exchanger. A cover should be tightly attached to prevent air leaks.

Ductwork dimensions are shown in the roof curb installation manual.

If desired, supply and return duct connections to the unit may be made with flexible connections to reduce possible unit operating sound transmission.

## VENTING

**NOTE: Venting is self-contained.**

## CONDENSATE DRAIN CONNECTION

### CONDENSATE DRAIN CONNECTION

A 3/4" NPT drain connection is supplied for condensate piping. An external trap must be installed for proper condensate drainage.

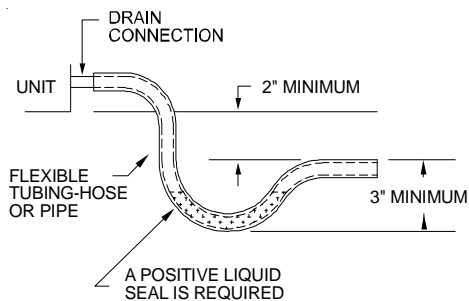

### Drain Connection

Install condensate drain trap as shown. Use 3/4" drain line and fittings or larger. Do not operate without trap.

### HORIZONTAL DRAIN

Drainage of condensate directly onto the roof may be acceptable; refer to local code. It is recommended that a small drip pad of either stone, mortar, wood or metal be provided to prevent any possible damage to the roof.

## CLEANING

Due to the fact that drain pans in any air conditioning unit will have some moisture in them, algae and fungus will grow due to airborne bacteria and spores. Periodic cleaning is necessary to prevent this build-up from plugging the drain.

## STARTUP, ADJUSTMENTS, AND CHECKS

### WARNING

#### HIGH VOLTAGE!

TO AVOID PERSONAL INJURY OR DEATH DUE TO ELECTRICAL SHOCK, BOND THE FRAME OF THIS UNIT TO THE BUILDING ELECTRICAL GROUND BY USE OF THE GROUNDING TERMINAL PROVIDED OR OTHER ACCEPTABLE MEANS. DISCONNECT ALL POWER BEFORE SERVICING OR INSTALLING THIS UNIT.



### PRE-STARTUP INSTRUCTIONS

### CAUTION

TO PREVENT PROPERTY DAMAGE OR PERSONAL INJURY, DO NOT START THE UNIT UNTIL ALL NECESSARY PRE-CHECKS AND TESTS HAVE BEEN PERFORMED.

Prior to the beginning of Startup, Adjustments, and Checks procedures, the following steps should be completed in the building.

**THERMOSTAT.** Set the thermostat in the conditioned space at a point at least 10°F below zone temperature. On cooling only models, set the thermostat system switch on COOL and the fan switch on AUTO. On heating/cooling models, set the thermostat system switch on COOL and the fan switch on AUTO.

**NIGHT SETBACK THERMOSTAT (OPTIONAL).** Set thermostat at a point at least 10°F below zone temperature.

### WARNING

#### MOVING MACHINERY HAZARD!

TO PREVENT POSSIBLE PERSONAL INJURY OR DEATH, DISCONNECT POWER TO THE UNIT AND PADLOCK IN THE "OFF" POSITION BEFORE SERVICING FANS.

### HEATING STARTUP

On new installations, or if a major component has been replaced, the operation of the unit must be checked.

Check unit operation as outlined in the following instructions. If any sparking, odors, or unusual sounds are encountered, shut off electrical power and recheck for wiring errors, or obstructions in or near the blower motors. **Duct covers must be removed before operating unit.**

The Startup, Adjustments, and Checks procedure provides a step-by-step sequence which, if followed, will assure the proper startup of the equipment in the minimum amount of

time. Air balancing of duct system is not considered part of this procedure. However, it is an important phase of any air conditioning system startup and should be performed upon completion of the Startup, Adjustments, and Checks procedure. The Startup, Adjustments, and Checks procedure at outside ambients below 55°F should be limited to a readiness check of the refrigeration system with the required final check and calibration left to be completed when the outside ambient rises above 55°F.

### TOOLS REQUIRED

- Refrigeration gauge and manifold
- Voltmeter
- Clamp-on ammeter
- Ohmmeter
- Test lead  
(Minimum #16 AWG with insulated alligator clips)
- Air temperature measuring device
- General refrigeration mechanics' tools

### TEMPORARY HEATING OR COOLING

If the unit is to be used for temporary heating or cooling, a "Startup, Adjustments, and Checks" must first be performed in accordance with this manual. Failure to comply with this requirement will void the warranty. **After** the machines are used for temporary heating or cooling, inspect the coils, fans, and motors for unacceptable levels of construction dust and dirt and install new filters.

### CONTRACTOR RESPONSIBILITY

The installing contractor must be certain that:

- All supply and return air ductwork is in place and corresponds with installation instructions.
- All thermostats are mounted and wired in accordance with installation instructions.
- All electric power, all gas, hot water or steam line connections, and the condensate drain installation have been made to each unit on the job. These main supply lines must be functional and capable of operating all units simultaneously.

### ROOF CURB INSTALLATION CHECK

Inspect the roof curb for correct installation. The unit and curb assembly should be level. Inspect the flashing of the roof mounting curb to the roof, especially at the corners, for good workmanship. Also check for leaks around gaskets. Note any deficiencies in a separate report and forward to the contractor.

### OBSTRUCTIONS, FAN CLEARANCE AND WIRING

Remove any extraneous construction and shipping materials that may be found during this procedure. Rotate all fans manually to check for proper clearances and that they rotate freely. Check for bolts and screws that may have jarred loose during shipment to the job site. Retighten if necessary. Retighten all electrical connections.

### PRE-STARTUP PRECAUTIONS

It is important to your safety that the unit has been properly grounded during installation. Check ground lug connection in main control box for tightness prior to closing circuit breaker or disconnect switch. Verify that supply voltage on line side of disconnect agrees with voltage on unit identification plate and is within the utilization voltage range as indicated in Appendix C Electrical Data.

**System Voltage** - That nominal voltage value assigned to a circuit or system for the purpose of designating its voltage class.

**Nameplate Voltage** - That voltage assigned to a piece of equipment for the purpose of designating its voltage class and for the purpose of defining the minimum and maximum voltage at which the equipment will operate.

**Utilization Voltage** - The voltage of the line terminals of the equipment at which the equipment must give fully satisfactory performance. Once it is established that supply voltage will be maintained within the utilization range under all system conditions, check and calculate if an unbalanced condition exists between phases. Calculate percent voltage unbalance as follows:

### Three Phase Models Only

$$3) \text{ PERCENT VOLTAGE UNBALANCE} = 100 \times \frac{2) \text{ MAXIMUM VOLTAGE DEVIATIONS FROM AVERAGE VOLTAGE}}{1) \text{ AVERAGE VOLTAGE}}$$

HOW TO USE THE FORMULA:

EXAMPLE: With voltage of 220, 216, and 213

1) Average Voltage =  $220+216+213=649 / 3 = 216$

2) Maximum Voltage Deviations from Average Voltage =  $220 - 216 = 4$

$$3) \text{ Percent Voltage Unbalance} = 100 \times \frac{4}{216} = \frac{400}{216} = 1.8\%$$

Percent voltage unbalance **MUST NOT** exceed 2%.

### FIELD DUCT CONNECTIONS

Verify that all duct connections are tight and that there is no air bypass between supply and return.

### FILTER SECTION CHECK

Remove filter section access panels and check that filters are properly installed. Note airflow arrows on filter frames.

### BELT DRIVE MODELS ONLY

#### BEARING CHECK

Prior to energizing any fans, check and make sure that all setscrews are tight so that bearings are properly secured to shafts.

For heat pump units, the airflow must be adjusted so that the air temperature rise falls within the ranges given stated on Data Plate (see Appendix A - Blower Performance).

**NOTE:** Section on high static tables may require a field motor change.

## TENSION AND ALIGNMENT ADJUSTMENT

Correct belt tension is very important to the life of your belt. Too loose a belt will shorten its life; too tight, premature motor and bearing failure will occur. Check your belt drive for adequate “run-in” belt tension by measuring the force required to deflect the belt at the midpoint of the span length. Belt tension force can be measured using a belt tension gauge, available through most belt drive manufacturers.

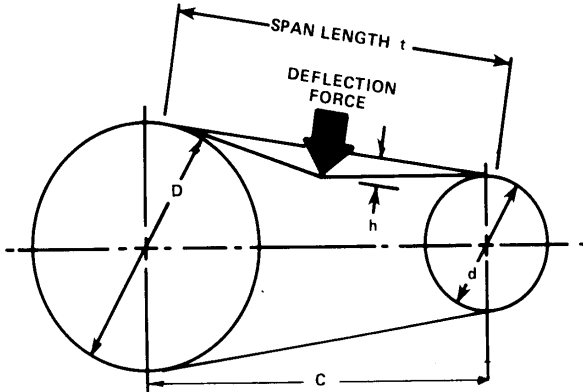

- t = Span length, inches
- C = Center distance, inches
- D = Larger sheave diameter, inches
- d = Smaller sheave diameter, inches
- h = Deflection height, inches

### DRIVE BELT TENSION ADJUSTMENT

MODEL	TYPE		SHEAVE DIAMETER (in)	DEFLECTION FORCE (lbs)		DEFLECTION (in)
	BELT	DRIVE		Used	New	
7.5 Ton	A, AX	Standard	2.6 to 3.6	4.5 ± .5	5.5 ± .5	1/4 ± 1/16
8.5 Ton			2.6 to 3.6	4.5 ± .5	5.5 ± .5	1/4 ± 1/16
10 Ton			3.0 to 4.0	4.5 ± .5	5.5 ± .5	1/4 ± 1/16
12.5 Ton			2.6 to 3.6	4.5 ± .5	5.5 ± .5	1/4 ± 1/16
7.5 Ton	A, AX	High Static	3.0 to 4.0	4.5 ± .5	5.5 ± .5	1/4 ± 1/16
8.5 Ton						1/4 ± 1/16
10 Ton						1/4 ± 1/16
12.5 Ton						1/4 ± 1/16

### RECOMMENDED POUNDS OF FORCE PER BELT

New V-belts will drop rapidly during the first few hours of use. Check tension frequently during the first 24 hours of operation. Tension should fall between the minimum and maximum force. To determine the deflection distance from a normal position, measure the distance from sheave to sheave using a straightedge or a cord. This is your reference line. On multiple belt drives, an adjacent undeflected belt can be used as a reference.

## EVAPORATOR FAN ROTATION CHECK (THREE PHASE MODELS ONLY)

Check that fan rotates clockwise when viewed from the drive side of unit and in accordance with rotation arrow shown on blower housing. If it does not, reverse the two incoming power cables at Single Point Power Block. In this case, repeat bearing check.

Do not attempt to change load side wiring. Internal wiring assures all motors and compressors will rotate in correct direction once evaporator fan motor rotation check has been made.

### ELECTRICAL INPUT CHECK

Make preliminary check of evaporator fan ampere draw and verify that motor nameplate amps are not exceeded. A final check of amp draw should be made upon completion of air balancing of the duct system (see Appendix C).

### REFRIGERATION SYSTEM CHECKS

Ensure the hold-down bolts on the compressor are secure and have not vibrated loose during shipment. Check that vibration grommets have been installed. Visually check all piping and clamps. The entire refrigeration system has been factory charged and tested, making it unnecessary to field charge. Factory charges are shown in Appendix C and on the unit nameplate.

Install service manifold hoses. Gauges should read saturation pressure corresponding to ambient temperature. Charge should be checked to obtain 12° to 15° of sub-cooling per system (i.e. compressor circuits).

### START-UP PROCEDURE AND CHECKLIST

Begin with power turned off at all disconnects.

1. Turn thermostat system switch to “Cool,” and fan switch to “Auto” and turn temperature setting as high as it will go.
2. Inspect all registers and set them to the normal open position.
3. Turn on the electrical supply at the disconnect.
4. Turn the fan switch to the “ON” position. The blower should operate after a 7-second delay.
5. Turn the fan switch to “Auto” position. The blower should stop after a 65 second delay.
6. Slowly lower the cooling temperature until first stage COOL (LOW COOL) starts. The blower, both fans, and first stage compressor should now be operating. Allow the unit to run 10 minutes, make sure cool air is being supplied by the unit.
7. Lower the cooling temperature further until second stage COOL (HIGH COOL) starts. The blower, both fans, and both compressors should now be operating. Allow the unit to run 10 minutes, make sure cool air is being supplied by the unit.

8. Turn the temperature setting to the highest position, stopping the unit. The indoor blower will continue to run for 65 seconds.
9. Turn the thermostat system switch to "OFF" and disconnect all power when servicing the unit.

16. If checking the unit in the wintertime, when the outdoor coil is cold enough to actuate the defrost control, observe at least one defrost cycle to make sure the unit defrosts completely.

#### FINAL SYSTEM CHECKS

17. Check to see if all supply and return air grilles are adjusted and the air distribution system is balanced for the best compromise between heating and cooling.
18. Check for air leaks in the ductwork. See Sections on **Air Flow Adjustments**.
19. Make sure the unit is free of "rattles", and the tubing in the unit is free from excessive vibration. Also make sure tubes or lines are not rubbing against each other or sheet metal surfaces or edges. If so, correct the trouble.
20. Set the thermostat at the appropriate setting for cooling and heating or automatic change over for normal use.
21. Be sure the Owner is instructed on the unit operation, filter, servicing, correct thermostat operation, etc.

#### REFRIGERATION PERFORMANCE CHECK

Under normal summertime (full load) operating conditions, superheat should be between 8°F and 12°F and sub-cooling measured at the condenser outlet should be 15°F (nominal). A 25°F to 35°F temperature difference should exist between the entering condenser air and the temperature corresponding to the compressor saturated discharge pressure. Check that compressor RLA corresponds to values shown in Appendix C. RLA draw can be much lower than values listed at low load conditions and low ambient condensing temperatures. Values in Appendix C can slightly exceed at high load conditions and high ambient condensing temperatures.

### HEAT PUMP OPERATION

#### COOLING CYCLE

When the heat pump is in the cooling cycle, it operates exactly as a Summer Air Conditioner unit. In this mode, all the charts and data for service that apply to summer air conditioning apply to the heat pump. Most apply on the heating cycle except that "condenser" becomes "evaporator", "evaporator" becomes "condenser", "cooling" becomes "heating".

#### HEATING CYCLE

The heat pump operates in the heating cycle by redirecting refrigerant flow through the refrigerant circuit external to the compressor. This is accomplished with through the reversing valve. Hot discharge vapor from the compressor is directed to the indoor coil (evaporator on the cooling cycle) where the heat is removed, and the vapor condenses to liquid. It then goes through the expansion device to the outdoor coil (condenser on the cooling cycle) where the liquid is evaporated, and the vapor goes to the compressor.



#### WARNING

#### HIGH VOLTAGE!

DISCONNECT ALL POWER BEFORE SERVICING OR INSTALLING THIS UNIT. MULTIPLE POWER SOURCES MAY BE PRESENT. FAILURE TO DO SO MAY CAUSE PROPERTY DAMAGE, PERSONAL INJURY OR DEATH.



#### HEAT PUMP START-UP PROCEDURE

10. Check the cooling mode for the heat pump in the same manner as above. The reversing valve is energized when the thermostat is placed in the cooling position. A clicking sound should be noticeable from the reversing valve. By lowering the temperature setting to call for cooling, the contractor is energized. The compressor, blower and fan should then be running. After the cooling mode is checked out, turn the thermostat system switch to "OFF".
11. Turn the thermostat system switch to "HEAT" and fan switch to "AUTO".
12. Slowly raise the heating temperature setting until heating makes contact. Both compressors, blower and both fans should now be running with the reversing valve in the de-energized (heating) position. After giving the unit time to settle out, make sure the unit is supplying heated air.
13. If the out door ambient is above 80°F, the unit may trip on its high pressure cut out when on heating. The compressor should stop. The heating cycle must be thoroughly checked, so postpone the test to another day when conditions are more suitable but-DO NOT FAIL TO TEST.  
If the out door ambient is low and the unit operates properly on the heating cycle, you may check the pressure cutout operation by blocking off the indoor return air until the unit trips.
14. If unit operates properly in the heating cycle, raise the temperature setting until the heating second stage makes contact. Supplemental resistance heat, if installed should now come on. Make sure it operates properly.  
**NOTE:** If outdoor thermostats are installed the outdoor ambient must be below the set point of these thermostats for the heaters to operate. It may be necessary to jumper these thermostats to check heater operation if outdoor ambient is mild.
15. For thermostats with emergency heat switch, return to step 11. The emergency heat switch is located at the bottom of the thermostat. Move the switch to emergency heat. The heat pump will stop, the blower will continue to run, all heaters will come on and the thermostat emergency heat light will come on.

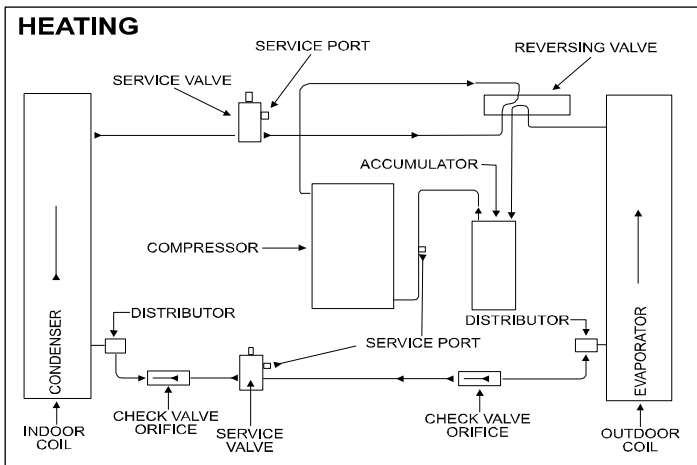
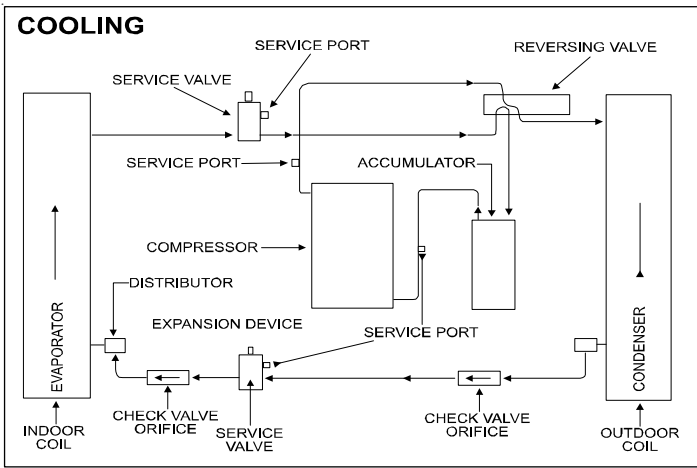

When the solenoid valve coil is operated either from heating to cooling or vice versa, the piston in the reversing valve to the low pressure (high pressure) reverse positions in the reversing valve.

The following figures show a schematic of a heat pump on the cooling cycle and the heating cycle. In addition to a reversing valve, a heat pump is equipped with an expansion device and check valve for the indoor coil, and similar equipment for the outdoor coil. It is also provided with a defrost control system.

The expansion devices are flowrator distributors and perform the same function on the heating cycle as on the cooling cycle. The flowrator distributors also act as check valves to allow for the reverse of refrigerant flow.

When the heat pump is on the heating cycle, the outdoor coil is functioning as an evaporator. The temperature of the refrigerant in the outdoor coil must be below the temperature of the outdoor air in order to extract heat from the air. Thus, the greater the difference in the outdoor temperature and the outdoor coil temperature, the greater the heating capacity of the heat pump. This phenomenon is a characteristic of a heat pump. It is a good practice to provide supplementary heat for all heat pump installations in areas where the temperature drops below 45° F. It is also a good practice to provide sufficient supplementary heat to handle the entire heating requirement should there be a component failure of the heat pump, such as a compressor, or refrigerant leak, etc.

Since the temperature of the refrigerant in the outdoor coil on the heating cycle is generally below freezing point, frost forms on the surfaces of the outdoor coil under certain weather conditions of temperature and relative humidity. Therefore, it is necessary to reverse the flow of the refrigerant to provide hot gas in the outdoor coil to melt the frost accumulation. This is accomplished by reversing the heat pump to the cooling cycle. At the same time, the outdoor fan stops to hasten the temperature rise of the outdoor coil and lessen the time required for defrosting. The indoor blower continues to run and the supplementary heaters are energized.

### DEFROST CONTROL

During operation the power to the circuit board is controlled by temperature sensors, which are clamped to feeder tubes entering the outdoor coils. Defrost timing periods of 30, 60 and 90 minutes may be selected by setting the circuit board jumper to 30, 60 and 90 respectively. Accumulation of time for the timing period selected starts when either sensor closes (approximately 31°F), and when the wall thermostat calls for heat. At the end of the timing period, the unit's defrost cycle will be initiated provided the sensor remains closed. When both sensors open (approximately 75°F), the defrost cycle is terminated and the timing period is reset. If the defrost cycle is not terminated due to the sensors temperature, a twelve minute override interrupts the unit's defrost period.

### AIR FLOW ADJUSTMENTS

The drive on the supply fan is typically set in the middle of the RPM range. The drive motor sheave pitch diameter is field adjustable for the required airflow. Refer to "Drive Adjustments" section below.

When the final adjustments are complete, the current draw of the motor should be checked and compared to the full load current rating of the motor. The amperage must not exceed the service factor stamped on the motor nameplate. The total airflow must not be less than that required for operation of the electric heaters or the furnace.

If an economizer is installed, check the unit operating balance with the economizer at full outside air and at minimum outside air. Upon completion of the air flow balancing, we recommend replacing the variable pitched motor sheave with a properly-sized fixed sheave. A matching fixed sheave will provide longer belt and bearing life and vibration free operation. Initially, it is best to have a variable pitched motor sheave for the purpose of airflow balancing, but once the balance has been achieved, fixed sheaves maintain alignment and minimize vibration more effectively. For direct drive units, move green wire for fan.

**NOTE:** Never run CFM below 350 CFM per ton, evaporator freezing or poor unit performance is possible.

## MOTOR SHEAVE ADJUSTMENTS

### VL, Vm & 2VP VARIABLE PITCH KEY TYPE MOTOR SHEAVES

The driving and driven motor sheaves should be in alignment with each other and the shafts parallel.

#### VL & Vm SHEAVES ADJUSTMENT

1. Loosen set screw "B" using a 5/32" Allen key.
2. Making half or full turns from closed position, adjust sheave pitch diameter for desired speed. **DO NOT OPEN MORE THAN FIVE FULL TURNS.**
3. Tighten set screw "B" securely over flat.
4. Carefully put on belts and adjust belt tension. **DO NOT FORCE BELTS OVER GROOVES.**
5. Ensure all keys are in place and the set screws tight before starting drive. Recheck set screws and belt tension after 24 hours service.

**NOTE:** Future adjustments should be made by loosening the belt tension and increasing or decreasing the pitch diameter of the sheave by half or full turns as required. Readjust belt tension before starting drive.

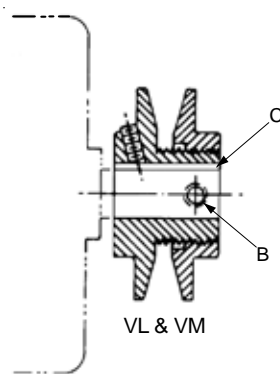

**NOTE:** Do not operate sheave with flange projecting beyond the hub end.

## MAINTENANCE

### WARNING

#### HIGH VOLTAGE!

DISCONNECT ALL POWER BEFORE SERVICING OR INSTALLING THIS UNIT. MULTIPLE POWER SOURCES MAY BE PRESENT. FAILURE TO DO SO MAY CAUSE PROPERTY DAMAGE, PERSONAL INJURY OR DEATH.



### WARNING

TO PREVENT PERSONAL INJURY OR DEATH DUE TO IMPROPER INSTALLATION, ADJUSTMENT, ALTERATION, SERVICE OR MAINTENANCE, REFER TO THIS MANUAL. FOR ADDITIONAL ASSISTANCE OR INFORMATION, CONSULT A QUALIFIED INSTALLER, SERVICE AGENCY OR THE GAS SUPPLIER.

### CAUTION

SHEET METAL PARTS, SCREWS, CLIPS AND SIMILAR ITEMS INHERENTLY HAVE SHARP EDGES, AND IT IS NECESSARY THAT THE INSTALLER AND SERVICE PERSONNEL EXERCISE CAUTION.

Your Self Contained Packaged Air Conditioner and Heat Pump should operate for many years without excessive service calls if the unit is installed properly. However it is recommended that the homeowner inspect the unit before a seasonal start up. The coils should be free of debris so adequate airflow is achieved. The return and supply registers should be free of any obstructions. The filters should be cleaned or replaced. These few steps will help to keep the product up time to a maximum. The Service section that follows should help in identifying problems if the unit does not operate properly.

#### FILTERS

### CAUTION

TO PREVENT PROPERTY DAMAGE DUE TO FIRE AND LOSS OF EQUIPMENT EFFICIENCY OR EQUIPMENT DAMAGE DUE TO DUST AND LINT BUILD UP ON INTERNAL PARTS, NEVER OPERATE UNIT WITHOUT AN AIR FILTER INSTALLED IN THE RETURN AIR SYSTEM.

Every application may require a different frequency of replacement of dirty filters. Filters must be replaced at least every three (3) months during operating seasons.

Dirty filters are the most common cause of inadequate heating or cooling performance. Filter inspection should be made at least every two months; more often if necessary because of local conditions and usage.

Dirty throwaway filters should be discarded and replaced with a new, clean filter.

Disposable return air filters are supplied with this unit. See the unit Specification Sheet or Technical Manual for the correct size and part number. To remove the filters, remove the filter access panel on return side of the unit.

#### CABINET FINISH MAINTENANCE

Use a fine grade automotive wax on the cabinet finish to maintain the finish's original high luster. This is especially important in installations with extended periods of direct sunlight.

#### CLEAN OUTSIDE COIL (QUALIFIED SERVICER ONLY)

The coil with the outside air flowing over it should be inspected annually and cleaned as frequently as necessary to keep the finned areas free of lint, hair and debris.

#### CONDENSER, EVAPORATOR, AND INDUCED DRAFT MOTORS

Bearings on the air circulating blower motor, condenser motor and the combustion fan motor are permanently lubricated. No additional oiling is required.

## LUBRICATION

The fan shaft bearings, the 1 to 2 HP supply fan motors the condenser fan motors and compressors are permanently lubricated.

## FUNCTIONAL PARTS

Refer to the unit Parts Catalog for a list of functional parts. Parts are available from your distributor.

## SERVICE

THE FOLLOWING INFORMATION IS FOR USE BY QUALIFIED SERVICE AGENCY ONLY: OTHERS SHOULD NOT ATTEMPT TO SERVICE THIS EQUIPMENT.

### Common Causes of Unsatisfactory Operation of Heat Pump on the Heating Cycle.

#### **INADEQUATE AIR VOLUME THROUGH INDOOR COIL**

When a heat pump is in the heating cycle, the indoor coil is functioning as a condenser. The return air filter must always be clean, and sufficient air volume must pass through the indoor coil to prevent excessive discharge pressure, and high pressure cut out.

#### **OUTSIDE AIR INTO RETURN DUCT**

Do not introduce cold outside air into the return duct of a heat pump installation. Do not allow air entering the indoor coil to drop below 65° F. Air below this temperature will cause low discharge pressure, thus low suction pressure, and excessive defrost cycling resulting in low heating output. It may also cause false defrosting.

## UNDERCHARGE

An undercharged heat pump on the heating cycle will cause low discharge pressure resulting in low suction pressure and frost accumulation on the outdoor coil.

## POOR "TERMINATING" SENSOR CONTACT

The unit's defrost terminating sensor must make good thermal contact with the outdoor coil tubing. Poor contact may not terminate the unit's defrost cycle quickly enough to prevent the unit from cutting out on high discharge pressure.

## MALFUNCTIONING REVERSING VALVE - THIS MAY BE DUE TO:

- Solenoid not energized** - In order to determine if the solenoid is energized, touch the nut that holds the solenoid cover in place with a screwdriver. If the nut magnetically holds the screwdriver, the solenoid is energized and the unit is in the cooling cycle.
- No voltage at unit's solenoid** - Check unit voltage. If no voltage, check wiring circuit.
- Valve will not shift:**
  - Undercharged** - check for leaks;
  - Valve Body Damaged** - Replace valve;
  - Unit Properly Charged** - If it is on the heating cycle, raise the discharge pressure by restricting airflow through the indoor coil. If the valve does not shift, tap it **lightly** on both ends with a screwdriver handle. **DO NOT TAP THE VALVE BODY.** If the unit is on the cooling cycle, raise the discharge pressure by restricting airflow through the outdoor coil. If the valve does not shift after the above attempts, cut the unit off and wait until the discharge and suction pressure equalize, and repeat above steps. If the valve does not shift, replace it.

## APPENDIX A BLOWER PERFORMANCE DATA BELT DRIVE - STANDARD

### CPC/H090 STANDARD BELT DRIVE HORIZONTAL

ESP, In H <sub>2</sub> O	TURNS OPEN																	
	0			1			2			3			4			5		
	CFM	RPM	BHP	CFM	RPM	BHP	CFM	RPM	BHP	CFM	RPM	BHP	CFM	RPM	BHP	CFM	RPM	BHP
0.1													3625	701	1.08	3309	660	0.86
0.3							3815	797	1.44	3468	747	1.11	3177	703	0.88	2796	663	0.68
0.5				3780	841	1.52	3405	803	1.23	3053	753	0.94	2608	709	0.68	2225	665	0.53
0.7	3687	885	1.6	3327	847	1.29	2968	805	1.02	2423	758	0.73						
0.9	3236	891	1.39	2850	852	1.1	2352	807	0.8									
1.1	2713	896	1.17															

### CPC/H102 STANDARD BELT DRIVE HORIZONTAL

ESP, In H <sub>2</sub> O	TURNS OPEN																	
	0			1			2			3			4			5		
	CFM	RPM	BHP	CFM	RPM	BHP	CFM	RPM	BHP	CFM	RPM	BHP	CFM	RPM	BHP	CFM	RPM	BHP
0.1													3475	698	1.05	3159	657	0.83
0.3							3665	794	1.41	3318	744	1.08	3027	700	0.85	2646	660	0.65
0.5				3630	838	1.49	3255	800	1.2	2903	750	0.91	2458	706	0.65			
0.7	3537	882	1.57	3177	844	1.26	2818	802	0.99									
0.9	3086	888	1.36	2700	849	1.07												
1.1	2563	893	1.14															

NOTE: High Static airflow requires installation of High Static Kit (HSKT\*), or factory-built High Static model. Unit factory shipped at 2.5 turns open. Tables represent dry coil without filter. To compensate for filter, add 0.08" to measured E.S.P. SCFM correction for wet coil = 4%.



# APPENDIX A BLOWER PERFORMANCE DATA

## BELT DRIVE - STANDARD

**CPC/H120 STANDARD BELT DRIVE HORIZONTAL**

ESP, In H <sub>2</sub> O	TURNS OPEN																	
	0			1			2			3			4			5		
	CFM	RPM	BHP	CFM	RPM	BHP	CFM	RPM	BHP	CFM	RPM	BHP	CFM	RPM	BHP	CFM	RPM	BHP
0.2										4562	736	1.58	4253	691	1.29	3893	642	1
0.4							4497	780	1.7	4200	736	1.41	3735	691	1.06	3322	648	0.83
0.6				4467	824	1.81	4221	784	1.55	3689	741	1.18						
0.8	4564	873	2.06	4170	830	1.68	3677	785	1.29									
1	4129	875	1.81	3498	835	1.34												
1.2	3558	879	1.49															

**CPC/H150 STANDARD BELT DRIVE HORIZONTAL**

ESP (IN W.C.)	0 TURNS		1 TURN		2 TURNS		3 TURNS		4 TURNS		5 TURNS			
	CFM	BHP	CFM	BHP	CFM	BHP	CFM	BHP	CFM	BHP	CFM	BHP		
0.2									5570	2.27	4935	1.70	4584	1.36
0.4	5871	3.20	5639	2.77	5307	2.31	4902	1.88	4637	1.55	4178	1.19		
0.6	5610	3.00	5358	2.57	5051	2.15	4603	1.72	4341	1.41				
0.8	5391	2.83	5010	2.33	4799	2.00	4393	1.61						
1.0	5078	2.59	4676	2.11	4448	1.79								
1.2	4521	2.20	4226	1.83										

**CPC/H090 STANDARD BELT DRIVE DOWN SHOT**

ESP, In H <sub>2</sub> O	TURNS OPEN																	
	0			1			2			3			4			5		
	CFM	RPM	BHP	CFM	RPM	BHP	CFM	RPM	BHP	CFM	RPM	BHP	CFM	RPM	BHP	CFM	RPM	BHP
0.1													3617	704	1.07	3293	653	0.84
0.3										3541	749	1.15	3179	704	0.88	2757	656	0.66
0.5							3447	798	1.23	3049	754	0.94	2606	710	0.71			
0.7				3400	848	1.33	2950	798	1.01	2474	754	0.75						
0.9	3303	890	1.41	2871	848	1.11	2408	804	0.82									
1.1	2838	897	1.23															

**CPC/H102 STANDARD BELT DRIVE DOWN SHOT**

ESP, In H <sub>2</sub> O	TURNS OPEN																	
	0			1			2			3			4			5		
	CFM	RPM	BHP	CFM	RPM	BHP	CFM	RPM	BHP	CFM	RPM	BHP	CFM	RPM	BHP	CFM	RPM	BHP
0.1													3467	701	1.04	3143	650	0.81
0.3										3391	746	1.12	3029	701	0.85	2607	653	0.63
0.5							3297	795	1.20	2899	751	0.91	2456	707	0.68			
0.7				3250	845	1.30	2800	795	0.98									
0.9	3153	887	1.38	2721	845	1.08												
1.1	2688	894	1.20															

**CPC/H120 STANDARD BELT DRIVE DOWN SHOT**

ESP, In H <sub>2</sub> O	TURNS OPEN																	
	0			1			2			3			4			5		
	CFM	RPM	BHP	CFM	RPM	BHP	CFM	RPM	BHP	CFM	RPM	BHP	CFM	RPM	BHP	CFM	RPM	BHP
0.2							4632	781	1.76	4203	742	1.41	3927	691	1.17	3510	658	0.9
0.4				4488	825	1.85	4183	783	1.54	3733	748	1.23	3512	693	1			
0.6	4442	880	2.02	4066	830	1.63	3717	786	1.31									
0.8	4001	885	1.77	3622	835	1.41												
1	3603	890	1.55															
1.2																		

**CPC/H150 STANDARD BELT DRIVE DOWN SHOT**

ESP (IN W.C.)	0 TURNS		1 TURN		2 TURNS		3 TURNS		4 TURNS		5 TURNS	
	CFM	BHP	CFM	BHP	CFM	BHP	CFM	BHP	CFM	BHP	CFM	BHP
0.2					5378	2.35	4967	1.92	4710	1.59	4512	1.33
0.4	5514	2.92	5349	2.56	4750	1.97	4583	1.71	4319	1.40	4030	1.13
0.6	5204	2.69	4919	2.27	4488	1.81	4258	1.54				
0.8	4830	2.42	4649	2.09	4019	1.55						
1.0	4497	2.19	4264	1.86								

NOTE: High Static airflow requires installation of High Static Kit (HSKT\*), or factory-built High Static model. Unit factory shipped at 2.5 turns open. Tables represent dry coil without filter. To compensate for filter, add 0.08" to measured E.S.P. SCFM correction for wet coil = 4%.

# APPENDIX A BLOWER PERFORMANCE DATA

## BELT DRIVE - HIGH STATIC

**CPC/H090 HIGH STATIC BELT DRIVE HORIZONTAL**

ESP, In H <sub>2</sub> O	TURNS OPEN																															
	0			1			2			3			4			5																
	CFM	RPM	BHP	CFM	RPM	BHP	CFM	RPM	BHP	CFM	RPM	BHP	CFM	RPM	BHP	CFM	RPM	BHP														
0.9	<b>DO NOT OPERATE</b>																													3447	902	1.54
1.1																											3398	956	1.65	3006	908	1.31
1.3																								3486	1008	1.87	2960	962	1.44			
1.5																					3514	1057	2.07	2949	1019	1.62						
1.7																			3388	1103	2.18	3036	1069	1.84								
1.9																			2959	1114	2											
2.1																			2527	1124	1.86											

**CPC/H120 HIGH STATIC BELT DRIVE HORIZONTAL**

ESP, In H <sub>2</sub> O	TURNS OPEN																															
	0			1			2			3			4			5																
	CFM	RPM	BHP	CFM	RPM	BHP	CFM	RPM	BHP	CFM	RPM	BHP	CFM	RPM	BHP	CFM	RPM	BHP														
0.8	<b>DO NOT OPERATE</b>																													4602	884	2.13
1																											4749	940	2.44	4180	885	1.89
1.2																											4251	945	2.12	3642	896	1.58
1.4																								4443	1001	2.5	3744	951	1.8			
1.6																					4587	1056	2.82	3971	1006	2.17						
1.8																			4760	1105	3.23	4071	1061	2.43	3342	1012	1.86					
2																			4364	1114	2.91	3579	1067	2.05								

**CPC/H150 HIGH STATIC BELT DRIVE HORIZONTAL**

ESP (IN W.C.)	0 TURNS		1 TURN		2 TURNS		3 TURNS		4 TURNS		5 TURNS	
	CFM	BHP	CFM	BHP	CFM	BHP	CFM	BHP	CFM	BHP	CFM	BHP
0.8									5858	3.51	5538	2.97
1.0							5894	3.85	5502	3.20	5282	2.78
1.2					5780	4.04	5570	3.55	5110	2.88	4869	2.47
1.4			5900	4.49	5501	3.77	5312	3.33	4793	2.64	4598	2.28
1.6	5860	4.76	5514	4.08	5257	3.54	4945	3.01	4382	2.34		
1.8	5615	4.49	5315	3.88	5020	3.32	4504	2.66				
2.0	5529	4.40	4906	3.49	4601	2.96						
2.2	4938	3.78	4541	3.15	4222	2.65						

**CPC/H090 HIGH STATIC BELT DRIVE DOWN SHOT**

ESP, In H <sub>2</sub> O	TURNS OPEN																															
	0			1			2			3			4			5																
	CFM	RPM	BHP	CFM	RPM	BHP	CFM	RPM	BHP	CFM	RPM	BHP	CFM	RPM	BHP	CFM	RPM	BHP														
0.9	<b>DO NOT OPERATE</b>																													3401	909	1.51
1.1																											3428	965	1.71	2943	915	1.3
1.3																								3471	1015	1.9	3012	971	1.5	2423	920	1.12
1.5																					3722	1063	2.25	3041	1023	1.67	2503	976	1.31			
1.7																					3359	1075	2.04	2540	1031	1.5						
1.9																			3381	1119	2.22	2890	1080	1.78								
2.1																			3089	1129	2.04											

**CPC/H120 HIGH STATIC BELT DRIVE DOWN SHOT**

ESP, In H <sub>2</sub> O	TURNS OPEN																	
	0			1			2			3			4			5		
	CFM	RPM	BHP	CFM	RPM	BHP	CFM	RPM	BHP	CFM	RPM	BHP	CFM	RPM	BHP	CFM	RPM	BHP
0.8												4435	940	2.22	4078	886	1.82	
1									4462	997	2.47	4103	944.5	2.05	3539	892	1.52	
1.2						4513	1054	2.75	4127	1003	2.26	3568	950	1.71				
1.4						4126	1064	2.52	3597	1008	1.92							
1.6				4438	1116	2.97	3759	1069	2.25									
1.8				3956	1124	2.55												
2	4050	1179	3.05	3473	1132	2.32												

**CPC/H150 HIGH STATIC BELT DRIVE DOWN SHOT**

ESP (IN W.C.)	0 TURNS		1 TURN		2 TURNS		3 TURNS		4 TURNS		5 TURNS	
	CFM	BHP	CFM	BHP	CFM	BHP	CFM	BHP	CFM	BHP	CFM	BHP
0.8							5978	3.87	5691	3.38	5324	2.81
1.0					5947	4.16	5656	3.58	5376	3.12	4933	2.52
1.2					5708	3.93	5459	3.40	4950	2.79	4441	2.18
1.4	5776	4.64	5510	4.07	5245	3.48	4844	2.88	4525	2.45		
1.6	5465	4.30	5199	3.74	4894	3.17	4404	2.54				
1.8	5145	3.97	4871	3.41	4495	2.83						
2.0	4805	3.63	4565	3.13	4142	2.55						
2.2	4429	3.27	4233	2.85								

NOTE: High Static airflow requires installation of High Static Kit (HSKT\*), or factory-built High Static model. Unit factory shipped at 2.5 turns open. Tables represent dry coil without filter. To compensate for filter, add 0.08" to measured E.S.P. SCFM correction for wet coil = 4%.

## APPENDIX B ELECTRICAL DATA

### ELECTRICAL DATA

MODELS	VOLTAGE (NAMEPLATE)	VOLTAGE LIMITATION		COMPRESSOR (ea)			OD FAN MOTORS (ea)			ID MOTOR APPL	ID FAN MOTOR (ea)	
		MIN	MAX	Qty	RLA	LRA	Qty	HP	RLA		HP	FLA
7.5 TON COOLER	208/230-60-3	187	253	2	13.1	83.1	2	1/4	1.40	BD STD STATIC	1.5	5.0
	460-60-3	414	506	2	6.1	41.0	2	1/4	0.80	BD STD STATIC	1.5	2.5
	575-60-3	518	633	2	4.4	33	2	1/4	0.60	BD STD STATIC	1.5	2.3
7.5 TON HEAT PUMP	208/230-60-3	187	253	2	13.1	83.1	2	1/4	1.40	BD STD STATIC	2.0	7.8
	460-60-3	414	506	2	6.1	41.0	2	1/4	0.80	BD STD STATIC	2.0	3.9
	575-60-3	518	633	2	4.4	33	2	1/4	0.60	BD STD STATIC	2.0	2.5
8.5 TON	208/230-60-3	187	253	2	14.5	98.0	2	1/4	1.40	BD STD STATIC	2.0	7.8
	460-60-3	414	506	2	6.3	55.0	2	1/4	0.80	BD STD STATIC	2.0	3.9
	575-60-3	518	633	2	6.0	41.0	2	1/4	0.60	BD STD STATIC	2.0	2.5
10 TON	208/230-60-3	187	253	2	16.0	110.0	2	1/3	2.40	BD STD STATIC	2.0	7.8
	460-60-3	414	506	2	7.8	52.0	2	1/3	1.20	BD STD STATIC	2.0	3.9
	575-60-3	518	633	2	6.4	38.9	2	1/3	0.90	BD STD STATIC	2.0	2.5
12.5 TON	208/230-60-3	187	253	2	22.4	149.0	2	1/3	2.40	BD STD STATIC	3.0	9.4
	460-60-3	414	506	2	10.6	75.0	2	1/3	1.20	BD STD STATIC	3.0	4.7
	575-60-3	518	633	2	7.70	54.0	2	1/3	0.90	BD STD STATIC	3.0	4.2

### MINIMUM AIR FLOW FOR ELECTRIC HEAT

UNIT	HEATER KIT MODEL NUMBER	MINIMUM CFM Downshot	MINIMUM CFM Horizontal
7.5 TON	EHK*-16	3000	3200
	EHK*-30	3000	3200
	EHK*-45	3000	3200
8.5 TON	EHK*-16	3400	3400
	EHK*-30	3400	3400
	EHK*-45	3400	3400
10 TON	EHK*-16	3500	3500
	EHK*-30	3500	3500
	EHK*-45	4000	4000
12.5 TON	EHK*-16	4000	4000
	EHK*-30	4300	4300
	EHK*-45	4500	4500



### ATTENTION INSTALLING PERSONNEL

Use only the heater kit specified for each model as dictated by the table above.

# APPENDIX C UNIT DIMENSIONS

	7.5	8.5	10	12.5
Y	52 7/8"	52 7/8"	52 7/8"	58 7/8"

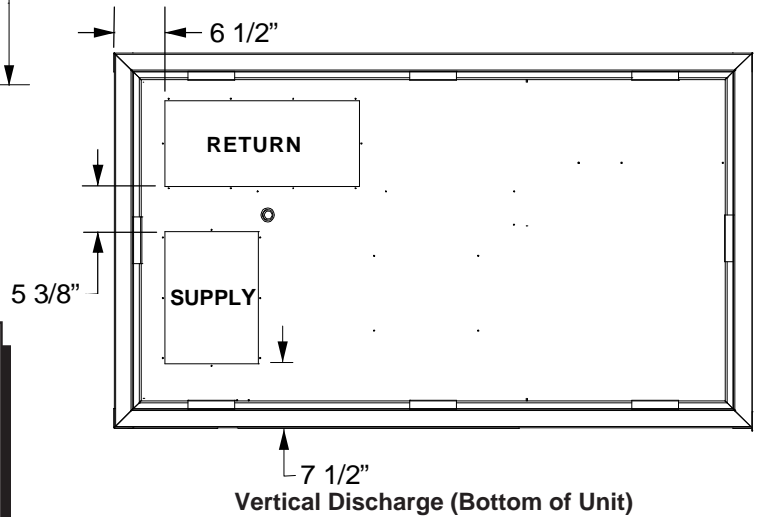
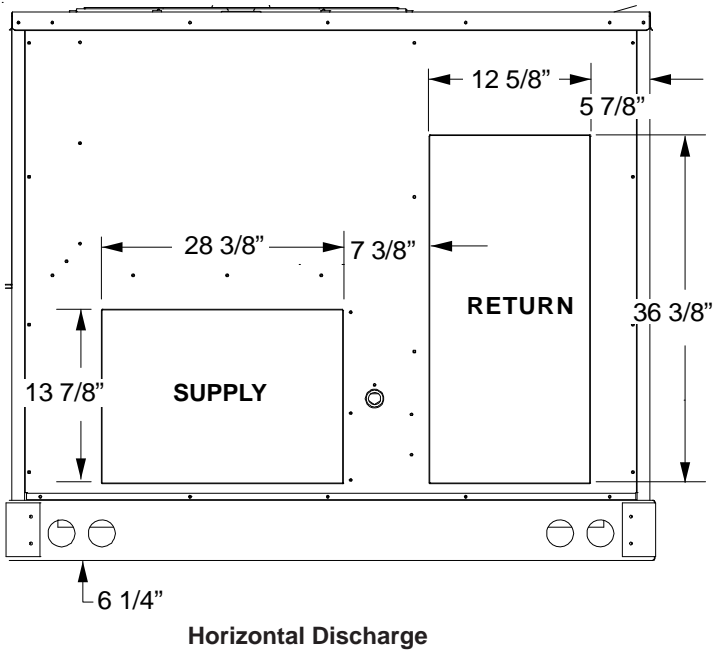
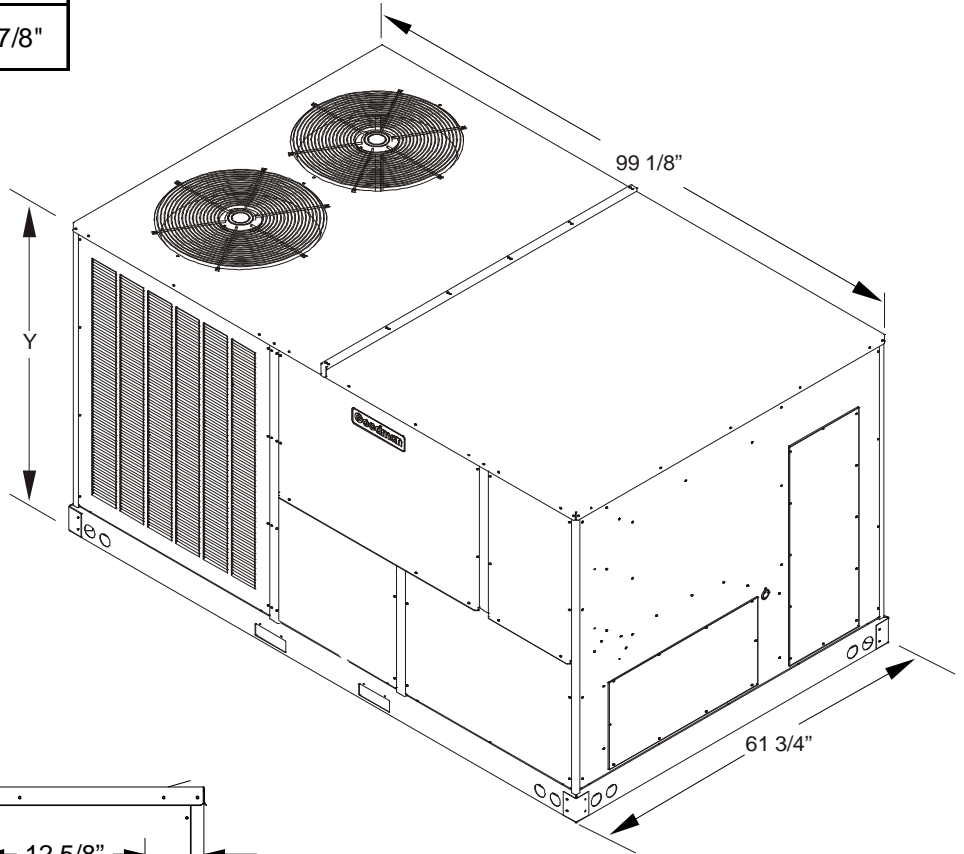

## NOTE

For horizontal discharge, remove the supply and return duct covers and place them over the vertical discharge return and supply openings. Install with insulation facing up, using the longer screws provided in the literature package.