



SM Series Heat pump Greensource

SM024 | SM036 | SM048 | SM060 | SM070



BOSCH

Installation, Operation and Maintenance Manual

6 720 220 406 (2015/02)

CONTENTS

Key to Symbols	3	DPS Water Flow Proving.....	38
Safety Warnings	3	Pump Relay	38
Standard package	3	Comfort Alert Module	38
Model Nomenclature	3	Smart Start Assist	39
General Description	5	Mode of Operation Notes.....	40
Moving and Storage	6	Heat Recovery Package	41
Initial Inspection	6	Water Tank Preparation	41
Location	6	HR Water Piping.....	41
Configurability	7	Water Tank Refill	42
Horizontal Configurability	7	Initial Start-Up	42
Required Tools	7	Sequence of Operation	43
Instructions - Left-Hand Unit (SMO**~1HZ~*L~***)	7	Cooling Mode	43
Instructions - Right-Hand Unit (SMO**~1HZ~*R~***)	10	Heating Mode	43
Counter-Flow configurability	13	Application Considerations	45
Vertical Configurability	13	Well Water Systems.....	45
Required Tools	15	Cooling Tower/Boiler Systems	45
Access to Internal Components.....	15	Geothermal Systems	47
Blower Re-Configuration	17	System Checkout	48
Condensate Drain Connection Re-configuration	20	Unit Start-up	48
HRP Switch Relocation	21	Maintenance	49
Electric Heat Relocation.....	22	Unit Check-Out Sheet	50
Electrical Box re-configuration	24	Customer Data.....	50
Reinstall All Panels	25	Unit Nameplate Data.....	50
Return and Discharge Duct Flanges	25	Operating Conditions.....	50
Pre Installation Unit Preparation	26	Auxiliary Heat	50
Corner Cap Installation Instructions.....	26	Troubleshooting	51
Mounting Vertical Units	27	Electronic Thermostat Installation	56
Mounting horizontal Units	27	Operating Temperatures and Pressures	57
Hanging Bracket kit	27	Airflow Tables	62
Condensate Drain	28	Water Side Pressure Drop Table	64
Duct System	29	Wiring Diagrams	65
Piping	29	WIRING HARNESS DRAWINGS	72
Electrical	30	Constant Torque Motor (SMO**~***~***~T*).....	72
Safety Devices and the UPM Controller	31	Constant Airflow Motor (SMO**~***~***~A*)	73
ECM INTERFACE BOARD	35	Spare Parts List	74
Dehumidification Method Selector	36	Dimensional Drawings	95
Constant Torque Motors (ECM).....	36	Horizontal - Straight Through	96
Options	37	Horizontal - Hanging bracket location	97
Hot Gas Reheat (HGRH)	37	Counter Flow.....	98
Electric Heat	37	CF Vertical	99
Heat Recovery Package (HRP)	37		
Constant Airflow Motor	38		

KEY TO SYMBOLS

Warnings



Warnings in this document are identified by a warning triangle printed against a grey background. Keywords at the start of the warning indicate the type and seriousness of the ensuing risk if measures to prevent the risk are not taken.

The following keywords are defined and can be used in this document:

- **NOTE** indicates a situation that could result in damage to property or equipment.
- **CAUTION** indicates a situation that could result in minor to medium injury.
- **WARNING** indicates a situation that could result in severe injury or death.
- **DANGER** indicates a situation that will result in severe injury or death.

Important Information



This symbol indicates important information where there is no risk to property or people.

SAFETY WARNINGS



WARNING: Installation and servicing of this equipment can be hazardous due to system pressure and electrical components. Only trained and qualified personnel should install, repair, or service the equipment.



WARNING: Before performing service or maintenance operations on the system, turn off main power to the unit. Electrical shock could cause personal injury or death.



WARNING: When working on equipment, always observe precautions described in the literature, tags, and labels attached to the unit. Follow all safety codes. Wear safety glasses and work gloves. Use a quenching cloth for brazing, and place a fire extinguisher close to the work area.



NOTE: To avoid the release of refrigerant into the atmosphere, the refrigerant circuit of this unit must be serviced only by technicians who meet local, state, and federal proficiency requirements.



NOTE: All refrigerant discharged from this unit must be recovered WITHOUT EXCEPTION. Technicians must follow industry accepted guidelines and all local, state, and federal statutes for the recovery and disposal of refrigerants. If a compressor is removed from this unit, refrigerant circuit oil will remain in the compressor. To avoid leakage of compressor oil, refrigerant lines of the compressor must be sealed after it is removed.



NOTE: To avoid equipment damage, DO NOT use these units as a source of heating or cooling during the construction process. Doing so may affect the unit's warranty. The mechanical components and filters will quickly become clogged with construction dirt and debris, which may cause system damage.

STANDARD PACKAGE

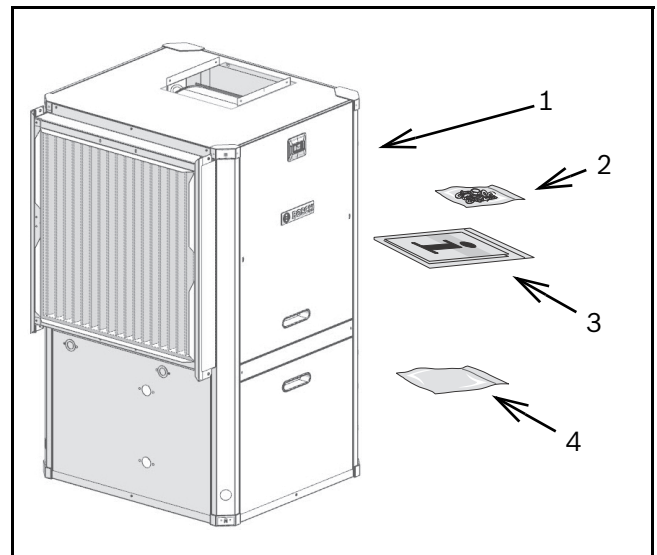

Figure # 1

- [1] SM Series Water-to-Air Heat Pump
- [2] Corner Caps Package
- [3] Installation and Operation Manual
- [4] Hanging Bracket kit (HZ unit only)

MODEL NOMENCLATURE

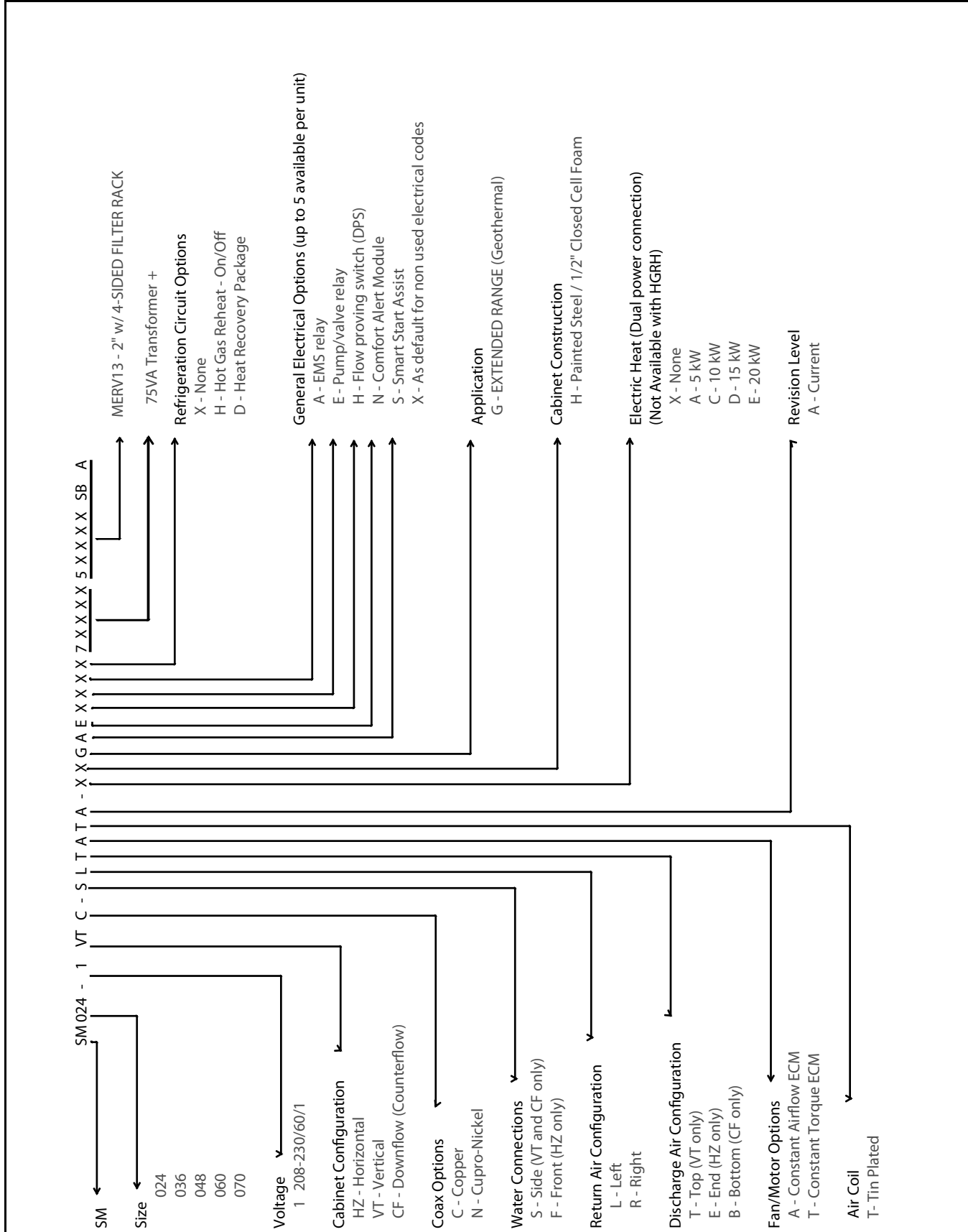

Figure # 2

GENERAL DESCRIPTION

SM Series Water-to-Air Heat Pumps provide the best combination of performance and efficiency available. All units are performance certified to American Heating and Refrigeration Institute (AHRI) ISO Standard 13256-1. All SM Water-to-Air Heat Pumps conform to UL1995 standard and are certified to CAN/CSA C22.2 No 236 by Intertek-ETL. The Water-to-Air Heat Pumps are designed to operate with entering fluid temperature between 20°F to 90°F in the heating mode and between 30°F to 120°F in the cooling mode



NOTE: Heat Pump operating under extreme conditions will have limitation on air/fluid flow rates and/or temperatures.



NOTE: 50° F Minimum Entering Water Temperature (EWT) is recommended for well water applications with sufficient water flow to prevent freezing. Antifreeze solution is required for all closed loop applications and EWT below 45°. Cooling Tower/Boiler and Geothermal applications should have sufficient antifreeze solution to protect against extreme conditions and equipment failure. Frozen water coils are not covered under warranty. Other equivalent methods of temperature control are acceptable.

SM Series Water-to-Air Heat Pumps are available in Vertical (VT), Horizontal (HZ) and Counter-Flow (CF) configurations. VT units are field convertible for three discharge/supply air orientations and left-hand (LH) or right-hand (RH) return configurations. HZ units have two field configurable discharge/supply air orientations. Several factory installed options are available: Hot Gas Reheat, Electric Heat, Heat Recovery Package, Smart Start Assist, Constant Airflow Blower Motor, DPS Water Flow Proving Switch, Auxiliary Pump Relay, and Comfort Alert Module. Electric Heat and Smart Start Assist are also available as field installed accessory. See Pg#37 for more detail.

Safety devices are built into each unit to provide the maximum system protection possible when properly installed and maintained. Each unit has externally mounted LCD error code display, allowing unit diagnosis without opening the cabinet.

Basic Horizontal unit layout and connections are shown in Figure #3. Refer to Dimensional Drawings for further detail, as well as Vertical and Counter Flow unit details. Pg#95 through Pg#95

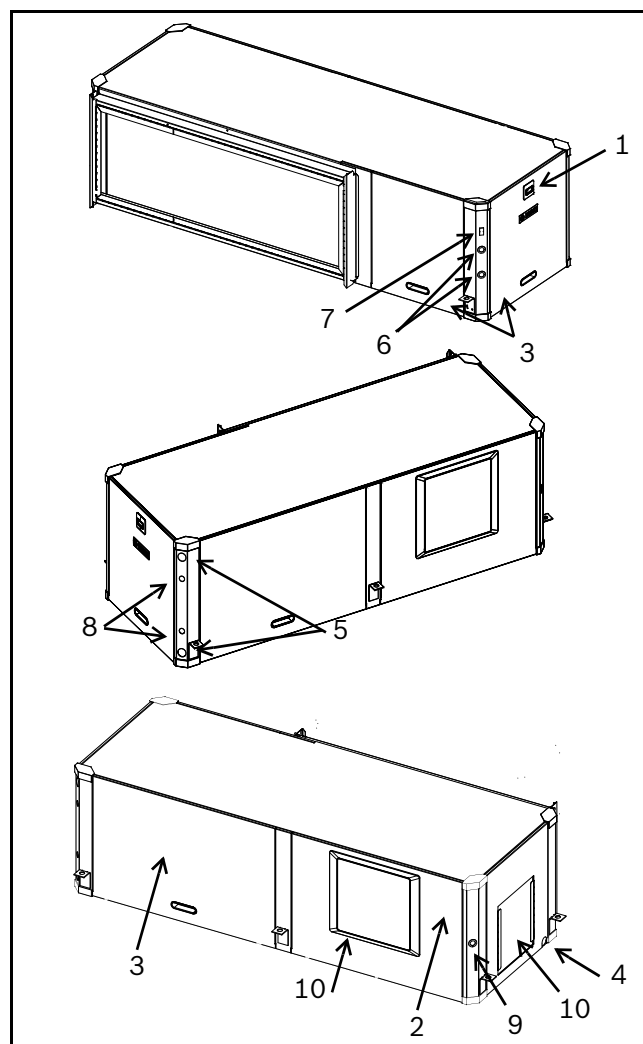

Figure # 3

- [1] LCD Error Code Display
- [2] Air handler access panel
- [3] Condensing section access panel
- [4] Condensate drain connection
- [5] Water connection
- [6] Heat Recovery water connection (Optional)
- [7] Heat Recovery disconnect switch (Optional)
- [8] Electrical connection knockout

[9] Electric Heat electrical connection knockout (Optional)

[10] Blower outlet (Supply Air)

MOVING AND STORAGE

If the equipment is not needed for immediate installation upon its arrival at the job site, it should be left in its shipping carton and stored in a clean, dry area. Units must only be stored or moved in the normal upright position as indicated by the “UP” arrows on each carton at all times.



WARNING: For storage If unit stacking is required, stack units as follows:

Vertical units: less than 6 tons, no more than two high.

Horizontal units: less than 6 tons, no more than three high.

INITIAL INSPECTION

Be certain to inspect all cartons or crates on each unit as received at the job site before signing the freight bill. Verify that all items have been received and that there are no visible damages; note any shortages or damages on all copies of the freight bill. In the event of damage or shortage, remember that the purchaser is responsible for filing the necessary claims with the carrier. Concealed damages not discovered until after removing the units from the packaging must be reported to the carrier within 24 hours of receipt.

LOCATION

Locate the unit in an indoor area that allows easy removal of the filter and access panels, and has enough room for service personnel to perform maintenance or repair. Provide sufficient room to make fluid, electrical, and duct connection(s). If the unit is located in a confined space such as a closet, provisions must be made for return air to freely enter the face of unit's air coil. On horizontal units, allow adequate room below the unit for a condensate drain trap and do not locate the unit above supply piping.



NOTE: These units are not approved for outdoor installation; therefore, they must be installed inside the structure being conditioned. Do not locate in areas that are subject to freezing.

CONFIGURABILITY

HORIZONTAL CONFIGURABILITY

The Horizontal Configuration water source heat pump is designed to have a field configurable blower orientation: end blow (default) and straight through. (Figure #4 and #5)

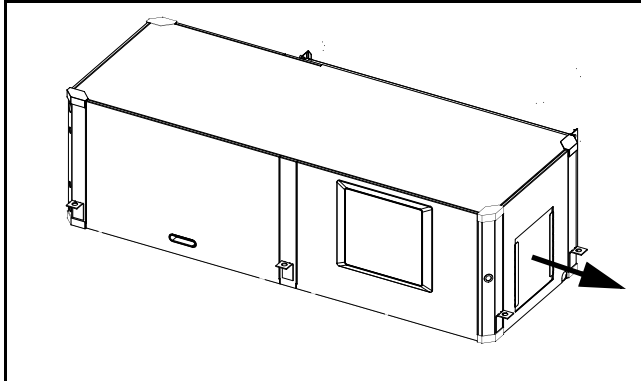

Figure # 4

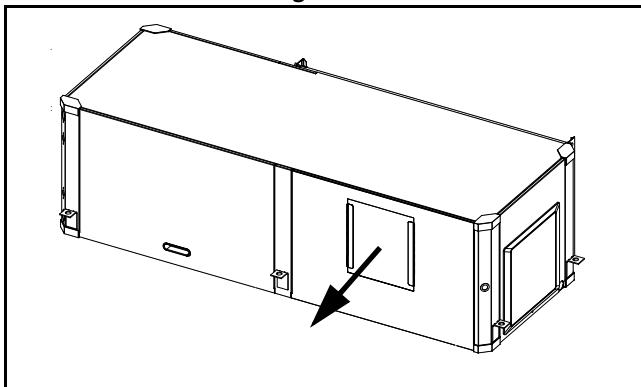

Figure # 5



Left-Hand and Right-hand Horizontal (HZ) units have different Blower Configuration instructions.

Left- Hand unit instructions refer to Pg#7 and Right-Hand unit instructions refer to Pg#10.



Internally mounted electric heat is only available in End Blow configuration.



Blower configuration changes should be done prior to unit being installed in the final location.

Required Tools

- 5/16" hex head driver
- 3/8" hex head driver
- 7/16" hex head driver
- Flat screw driver
- Phillips screw driver

- 1/4" hex head driver
- Needle nose pliers
- 5/16"-1/4" ratchet wrench



NOTE: Discharge air configuration change is not possible on Heat Pumps equipped with Electric Heat Option.

Instructions - Left-Hand Unit (SM0**-1HZ-*L*-.**)

1. Remove and retain end and side panels.(Figure #6)

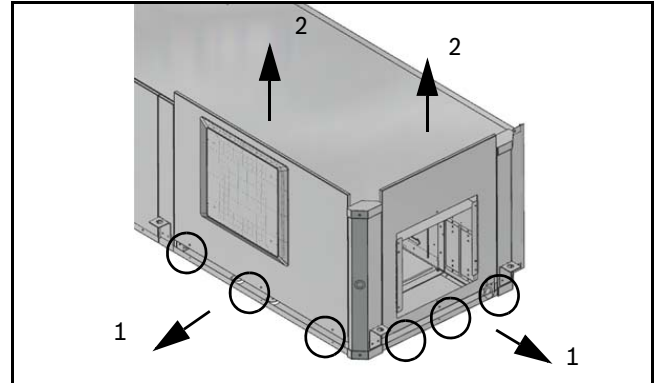

Figure # 6

2. Disconnect blower motor wiring and ground wire fastened to blower housing.(Figure#7)

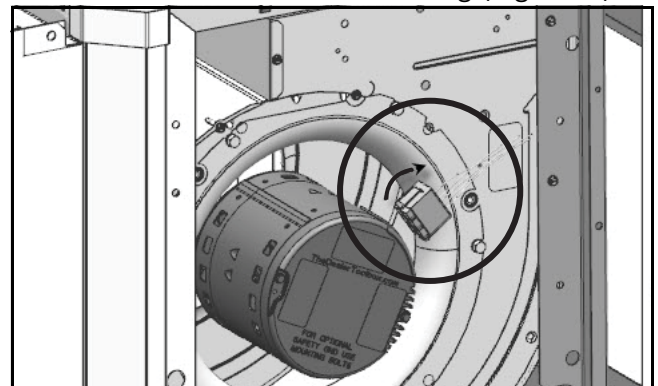

Figure # 7

3. Remove and retain bracket by removing (3) screws. (Figure #8)

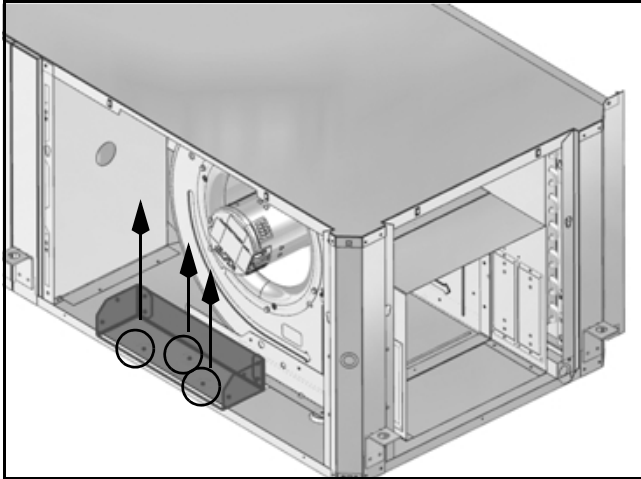

Figure # 8

4. Loosen blower assembly by removing (4) screws. (Figure #9)

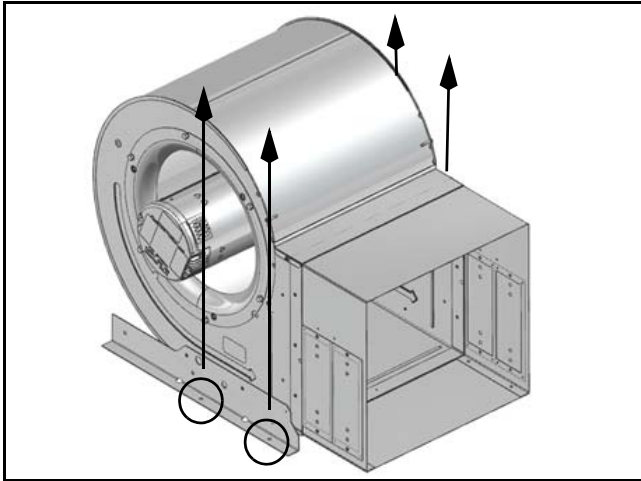

Figure # 9

5. Remove and retain bracket by removing (2) screws. (Figure #10)

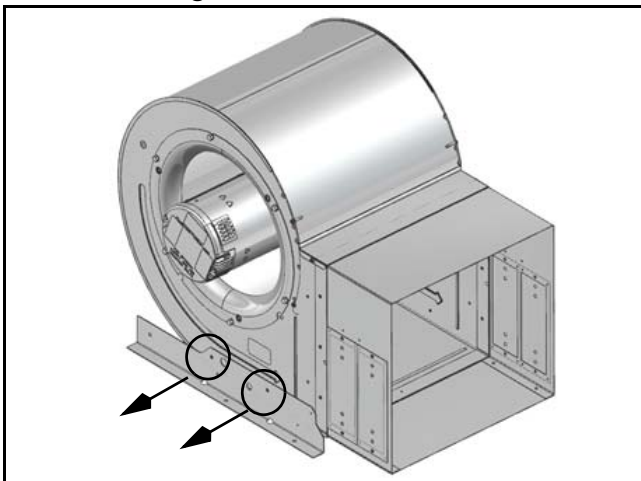

Figure # 10

6. Rotate the blower into its new position. (Figure #11)

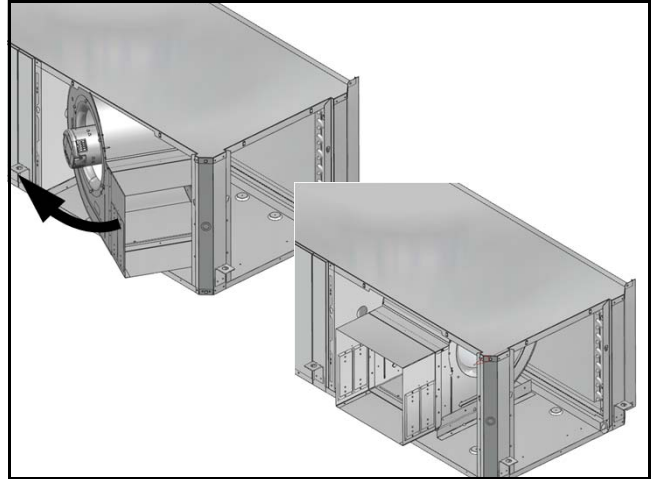

Figure # 11

7. Remove and retain remaining bracket by removing (2) screws. (Figure #12)

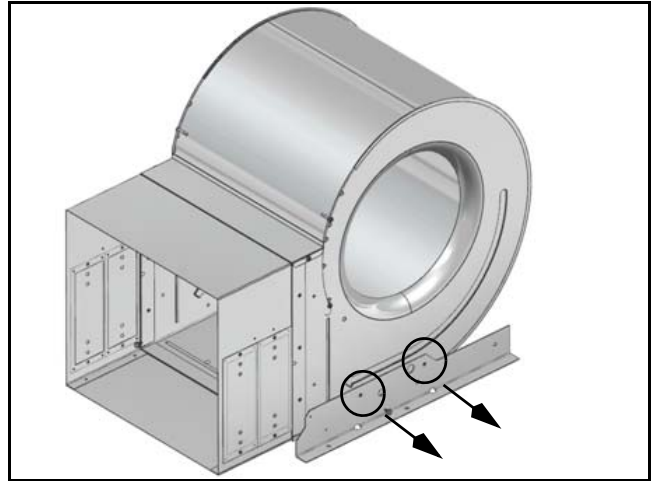

Figure # 12

8. Remove the blower assembly by sliding it forward. (Figure #13)

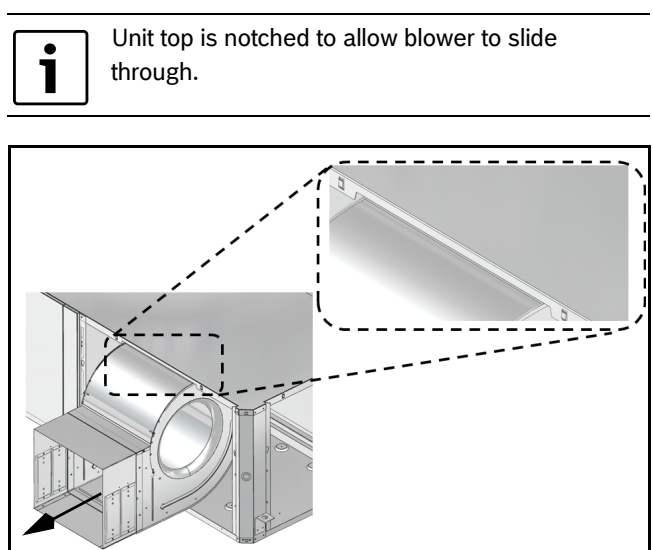

Figure # 13

i Unit top is notched to allow blower to slide through.

9. Remove and discard blower collar by removing (8) screws. (Figure #14)

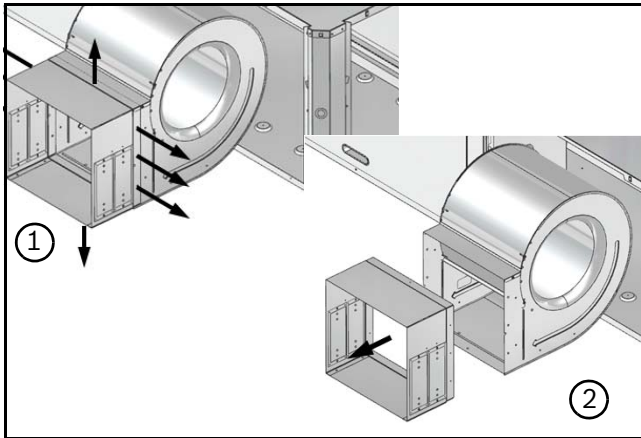

Figure # 14

10. Reorient the blower assembly 180 degree with blower “belly” down and slide back into the cabinet. (Figure #15)

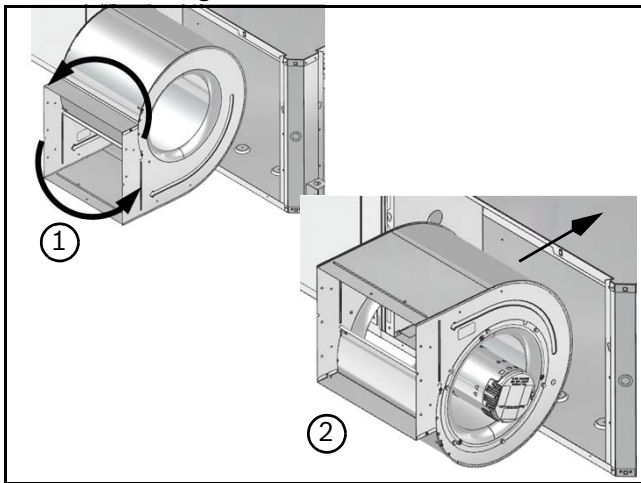

Figure # 15

11. Reinstall bracket in the new vertical position using (2) screws. (Figure #16)

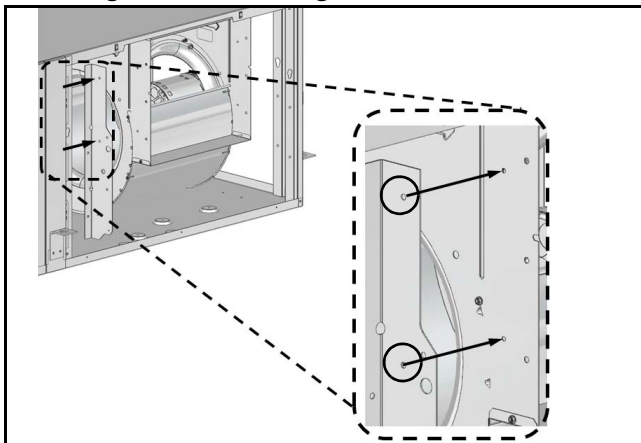

Figure # 16

12. Reinstall bracket removed in step (#3) using (3) screws in the same location. (Figure#17)

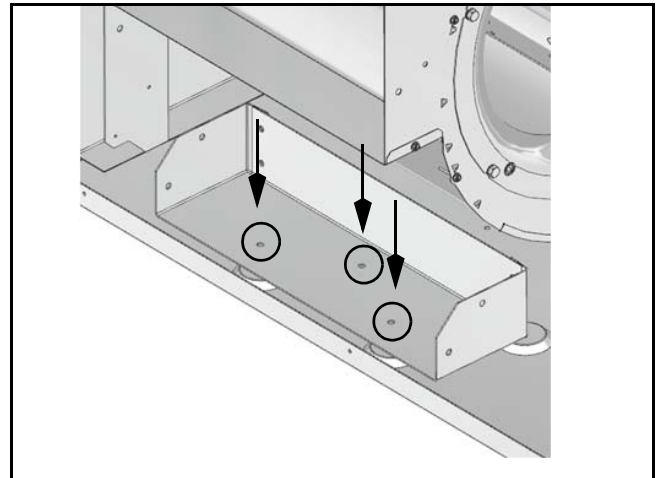

Figure # 17

13. Reinstall remaining bracket using (2) screws. (Figure#18)

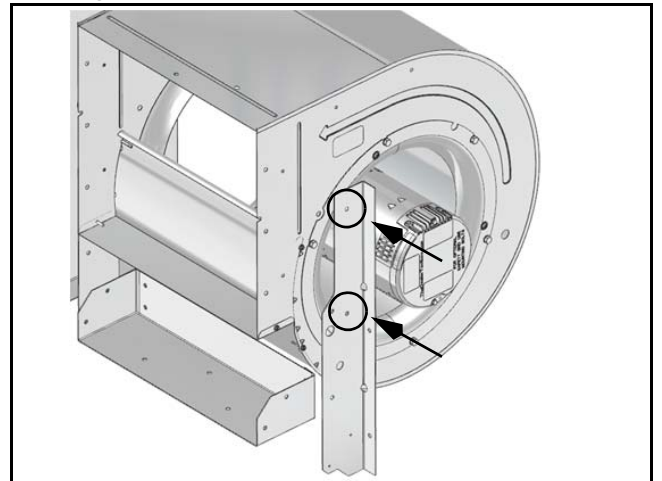

Figure # 18

14. Connect vertical and horizontal brackets by installing (4) screws. (Figure#19)

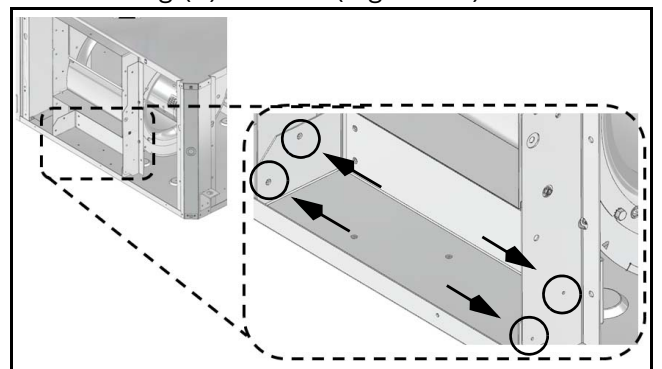

Figure # 19

15. Reconnect blower motor wiring and ground wire.

- Remove and retain plastic Blower opening cover by removing (6) screws and reinstall it in the new location (Figure#20 and #21)

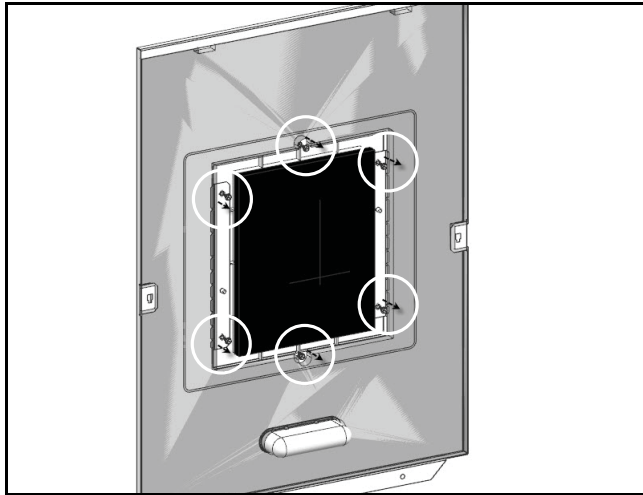

Figure # 20

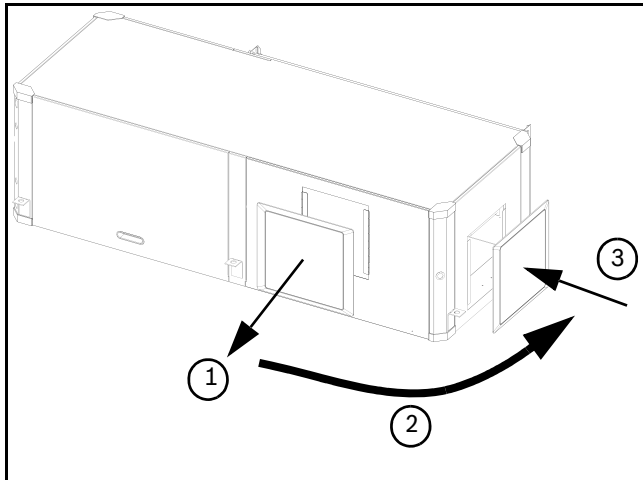

Figure # 21

- Reinstall all unit panels.

Instructions - Right-Hand Unit (SM0**-1HZ-*R*-.**)

- Remove and retain end and side panels.(Figure#22)

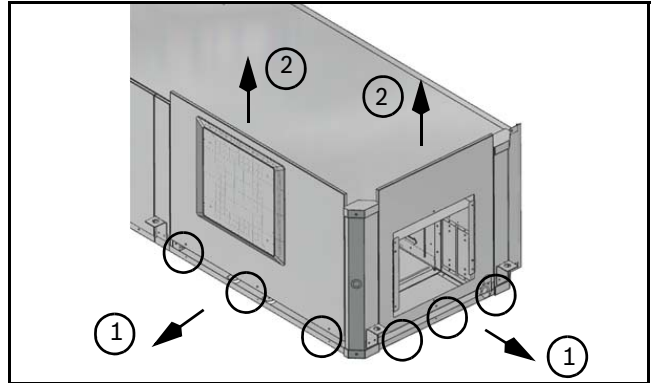

Figure # 22

- Disconnect blower motor wiring and ground wire fastened to blower housing.(Figure#23)

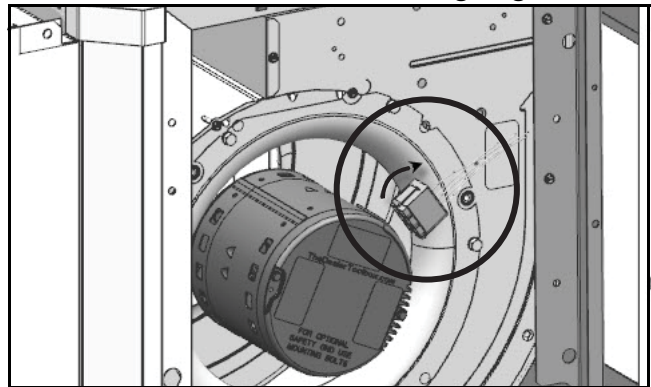

Figure # 23

- Remove and retain (4) screws under the blower collar. (Figure #24)

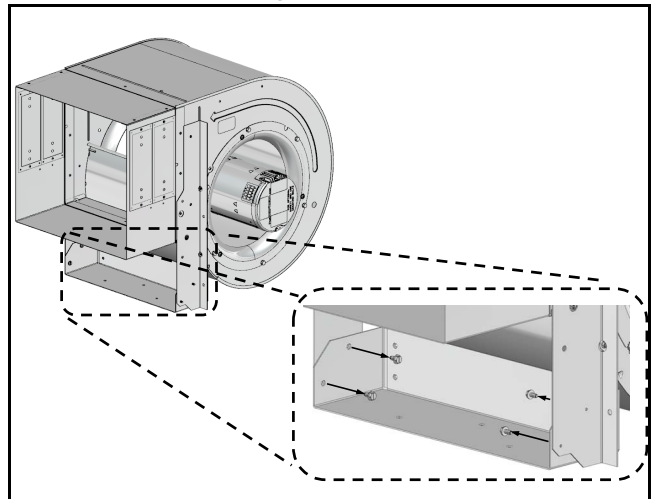

Figure # 24



NOTE: Air coil is in close proximity to the blower. Air coil fins are easily damaged. Great care must be taken during this step to avoid coil damage. Shipping cardboard can be used as protection during blower removal and installation.

- Slide blower assembly away from mounting bracket. (Figure #25)

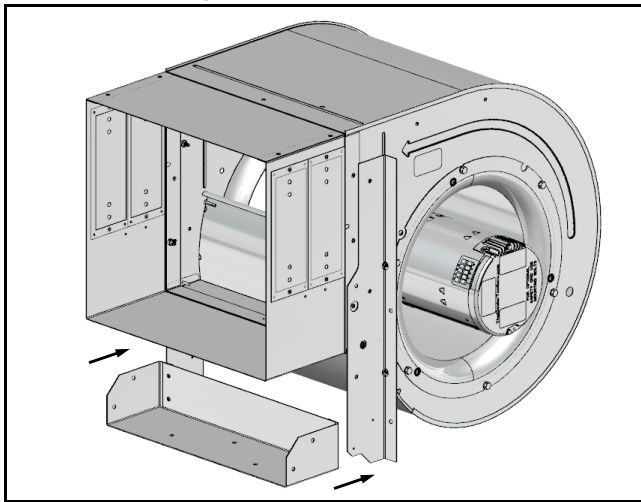

Figure # 25

- Remove and retain (1) vertical bracket by removing (2) screws. (Figure #26)

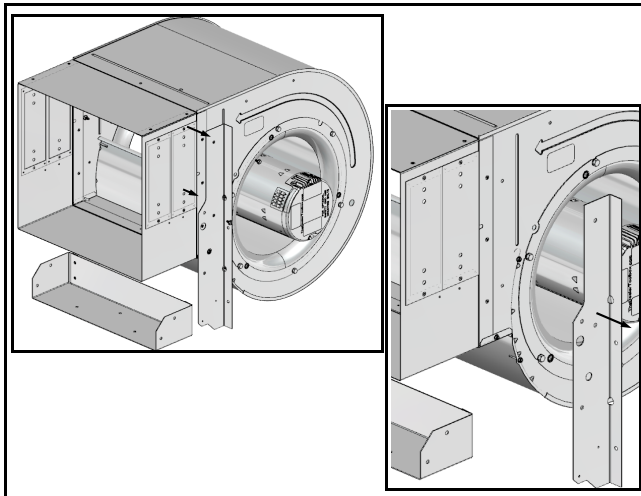

Figure # 26

- Remove and discard horizontal blower bracket by removing (3) screws. (Figure #27)

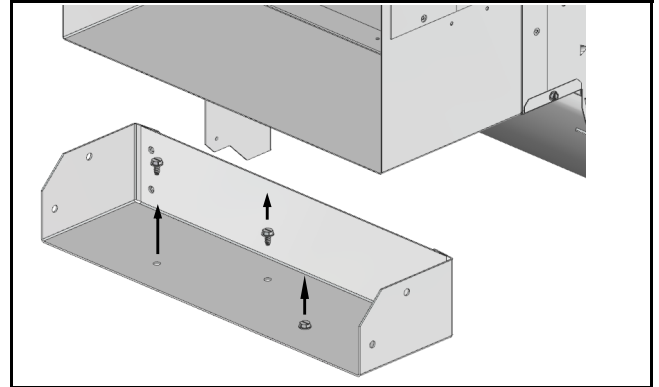

Figure # 27

- Rotate the blower into its new position. (Figure #28)

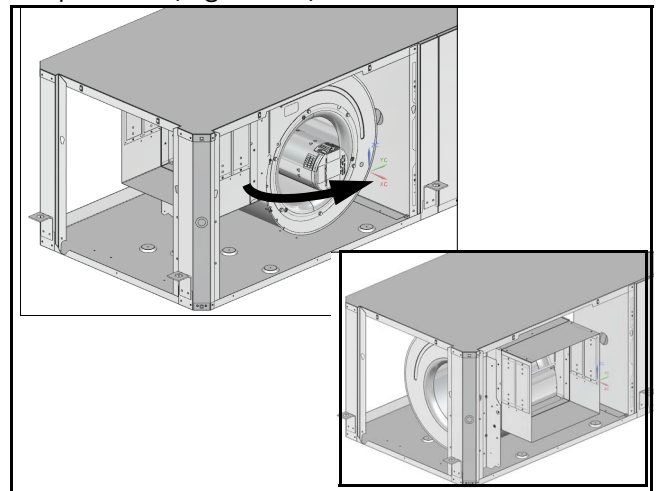

Figure # 28

- Remove and retain remaining vertical blower bracket by removing (2) screws. (Figure #29)

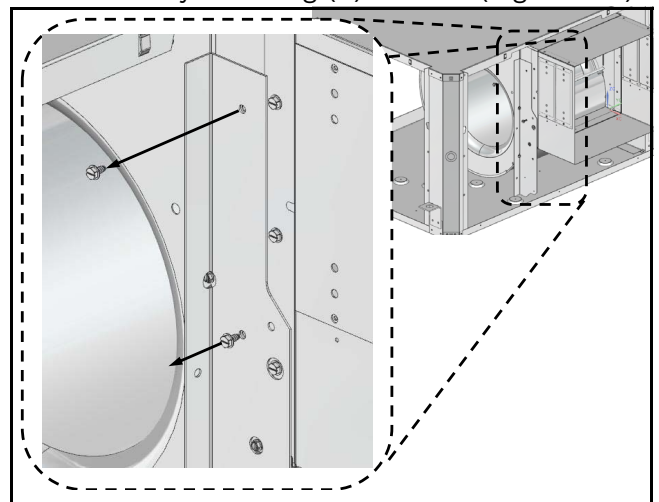

Figure # 29

9. Remove the blower assembly by sliding it forward. (Figure #30)

i Unit top is notched to allow blower to slide through.

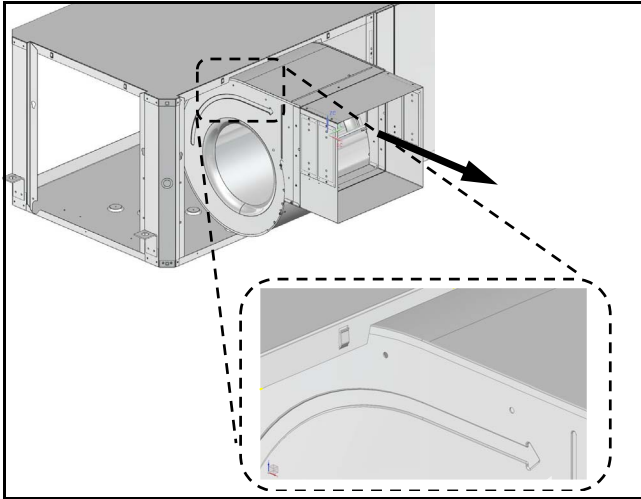

Figure # 30

10. Remove and discard blower collar by removing (8) screws. (Figure #31)

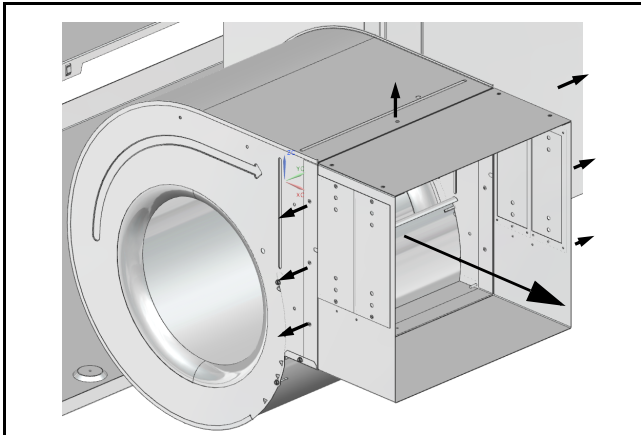

Figure # 31

11. Reorient the blower assembly 180 degree with blower "belly" up. (Figure #32)

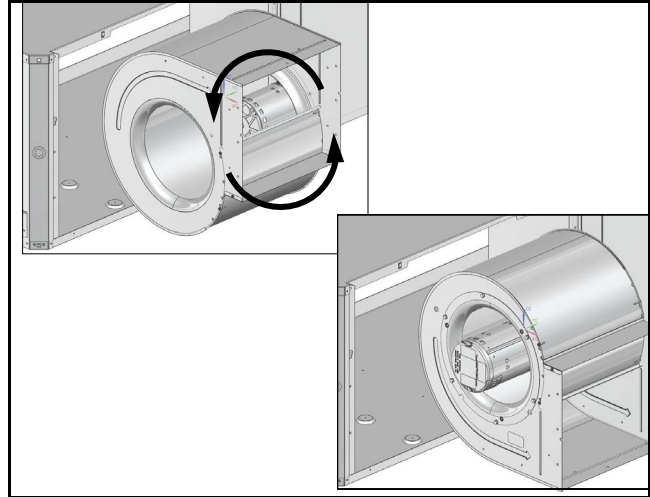

Figure # 32

12. Move the blower back into the cabinet. (Figure #33)

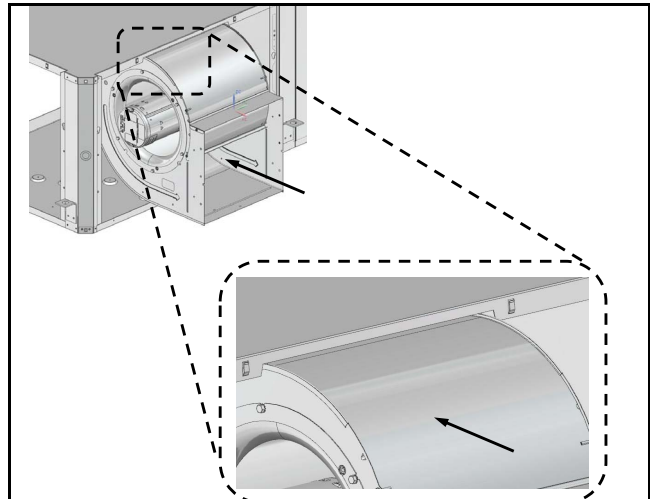

Figure # 33

13. Reinstall (2) vertical blower brackets in the new horizontal position using (4) screws. (Figure #34)

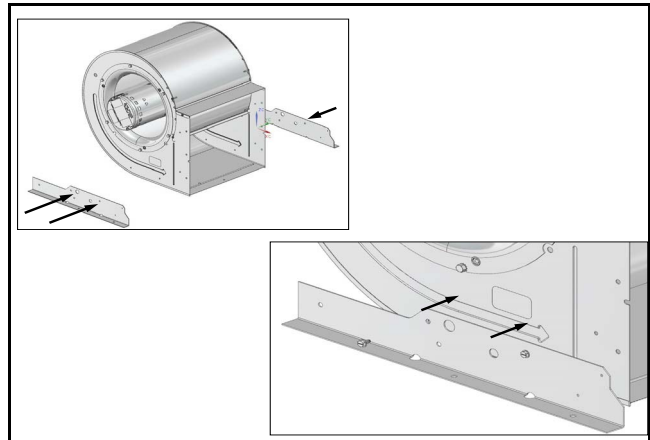

Figure # 34

14. Secure (2) the now horizontal blower brackets to the unit base using (4) screws. (Figure#35)

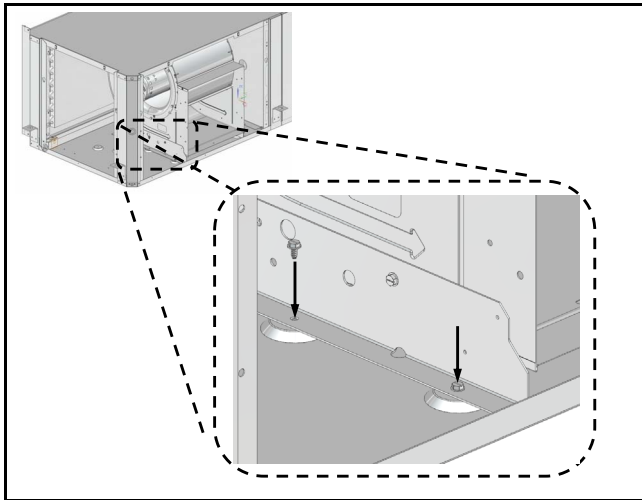

Figure # 35

15. Reconnect blower motor wiring and ground wire.
16. Remove and retain plastic Blower opening cover by removing (6) screws and cutting/tearing insulation at perforations around the perimeter of cover. Reinstall it in the new location (Figure#36 and #37)

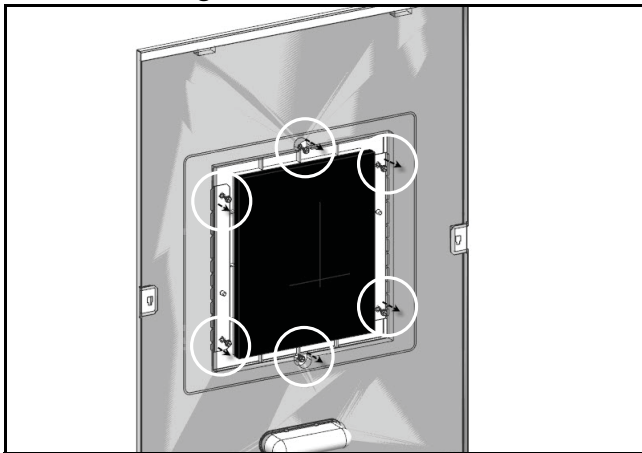

Figure # 36

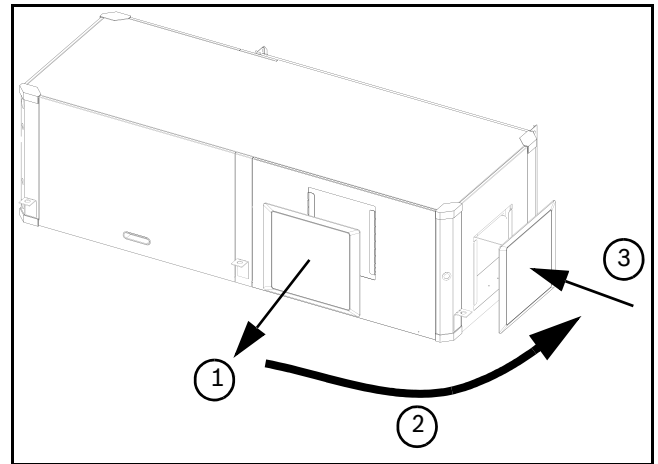

Figure # 37

17. Reinstall all unit panels.

COUNTER-FLOW CONFIGURABILITY

The Counter-Flow Configuration water source heat pump is a dedicated down flow configuration. Available from the factory in Left-hand and right-hand return air configurations.

VERTICAL CONFIGURABILITY

The Vertical (VT) Configuration water source heat pump is designed to be field configured for various configurations. This is achieved by relocating Electrical box (E-box), unit panels and reorienting blower to discharge UP, BACK OR SIDE. See Figure #37 through #41 for more detail.



The unit, as shipped from the factory, does not have configuration on the discharge air from to side or back, field configuration kit is required, (sold as an accessory Kit).



Discharge air configuration change is not possible on Heat Pumps equipped with Electric Heat Option.



Blower, E-box and panel configuration changes should be done prior to unit being installed in the final location.

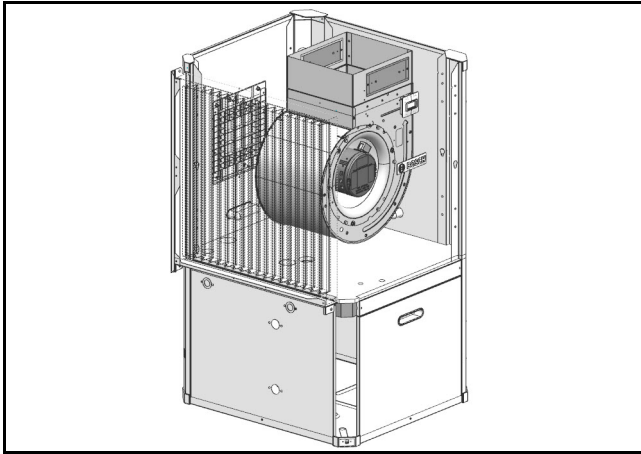

Figure # 38 Top Discharge (Default)

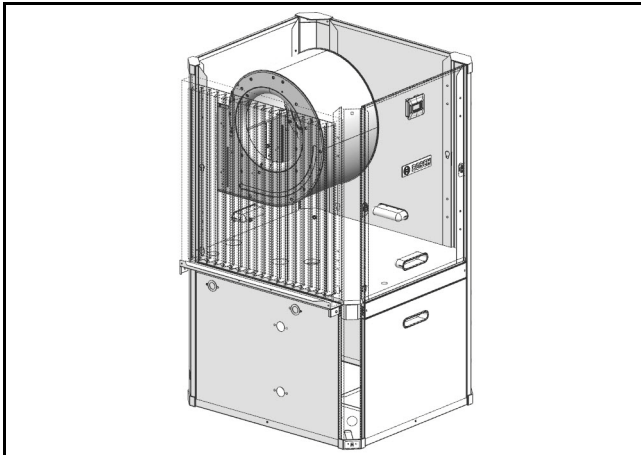

Figure # 39 Back Discharge

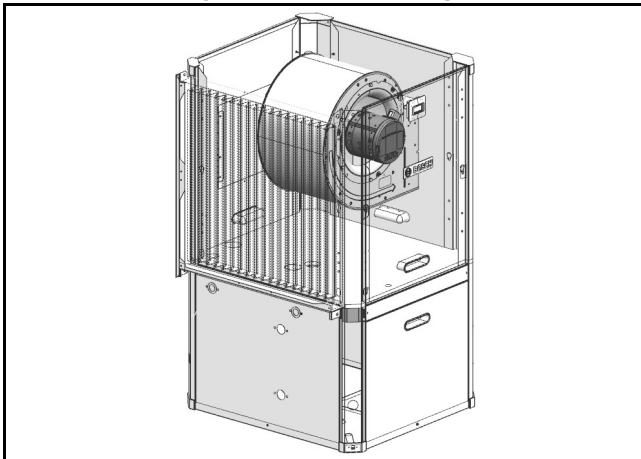

Figure # 40 Side Discharge

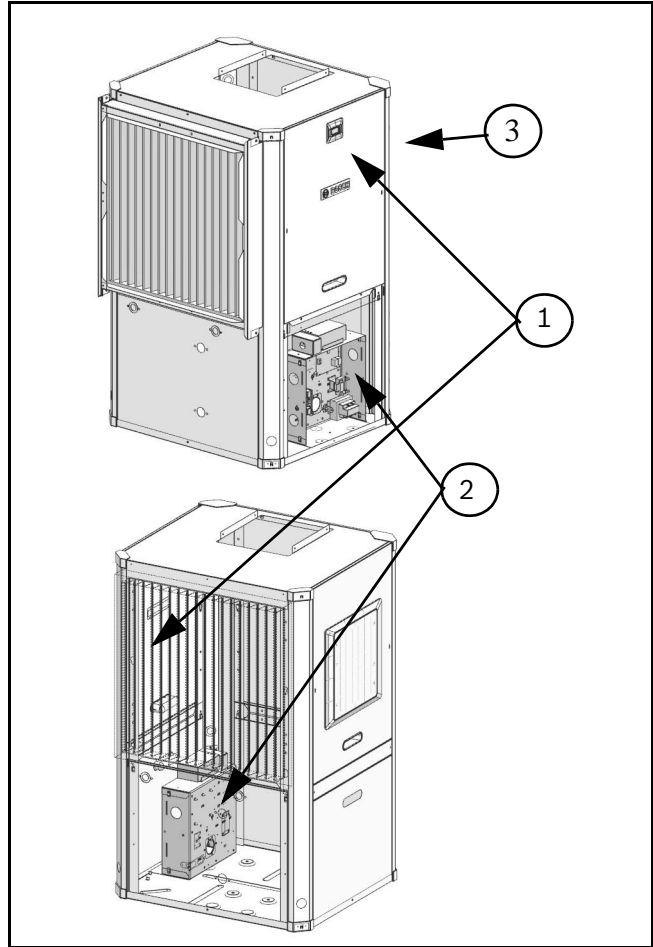

Figure # 41

- [1] Logo/Front Panel
- [2] Electrical Box
- [3] Default Configuration (can be ordered as either right or left hand return)



Internally mounted electric heat is only available in Top Discharge configuration. See table below for details

Blower Orientation and Electric Heat Compatibility		
Blower	Up	Yes Internally or Duct Mounted
	Back	Duct Mounted
	Side	Duct Mounted

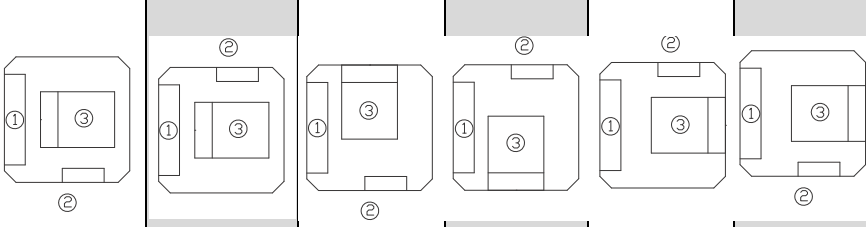
Required steps	Possible unit configurations					
<p><i>How to use this table:</i></p> <ul style="list-style-type: none"> Select desired configuration from “possible unit configurations”. Instructions with “X” have to be performed to reconfigure the unit. 						
	Left return, top discharge	Right return, top discharge	Left return, rear discharge	Right return, rear discharge	Right return, left discharge	Left return, right discharge
ACCESS TO INTERNAL COMPONENTS (PG#15)		X	X	X	X	X
BLOWER RE-CONFIGURATION (PG#17)			X	X	X	X
E-BOX CONFIGURATION (PG#24)		X		X	X	
ELECTRIC HEAT RELOCATION* (PG#22)		X*				
CONDENSATE DRAIN RELOCATION (PG#20)		X		X	X	
HRP SWITCH* (PG#21)	X*	X*		X*	X*	
REINSTALL PANELS (PG#25)		X	X	X	X	X
<p>*APPLIES IF OPTION IS INSTALLED [1] AIR COIL [2] E-BOX (UNIT FRONT) [3] BLOWER X APPLICABLE STEP</p>						



All heat pumps are supplied with panel belt which needs to be removed to access screws for panel removal. The panels have additional internal fasteners to prevent any air leakage.



For safety precautions two persons are required to perform this operation.

Required Tools

- 5/16" hex head driver
- 3/8" hex head driver
- 7/16" hex head driver
- Flat screw driver
- Phillips screw driver
- 1/4" hex head driver
- Needle nose pliers

Access to Internal Components

- Using a Flat Screw driver remove and retain Panel Belt by inserting the screwdriver into the slot and releasing the catch. (Figures#42and#43)



The belt is held in place by a clip on one side and an interference fit on the other end.

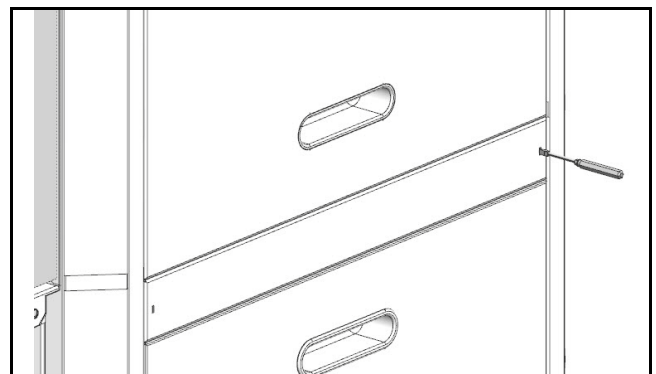

Figure # 42

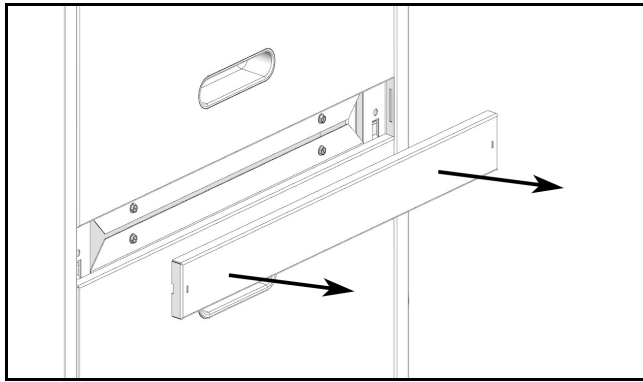

Figure # 43

2. Remove and retain Condensing Section access panels (bottom panel) by removing (3) screws. (Figure #44)

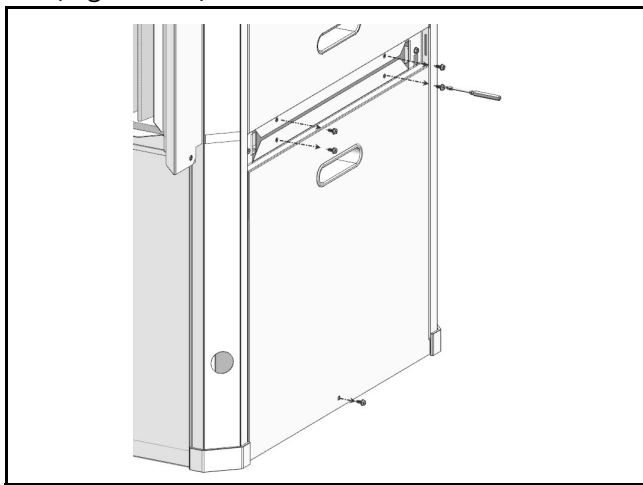



Figure # 44

3. Remove and retain Air Handler Panel by lifting up and out as shown in Figure #46. Remove panel about 12" away from the cabinet and unplug LCD screen wiring. (Figures #45 and #46)



The unit panel mounted diagnostic display is connected to the heat pump controls with a wire harness. Use care when removing the display panel and carefully disconnect and reconnect the harness when repositioning the panel.

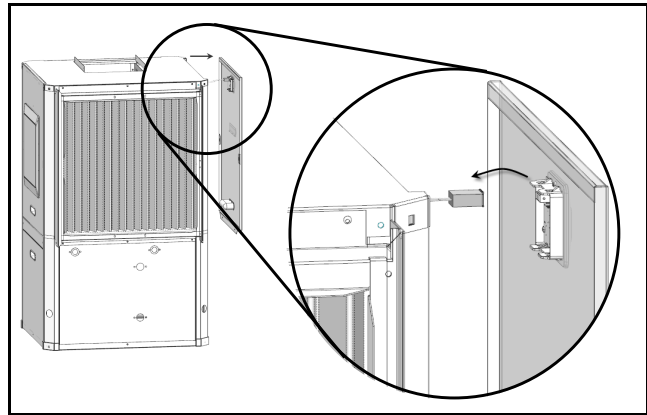

Figure # 45

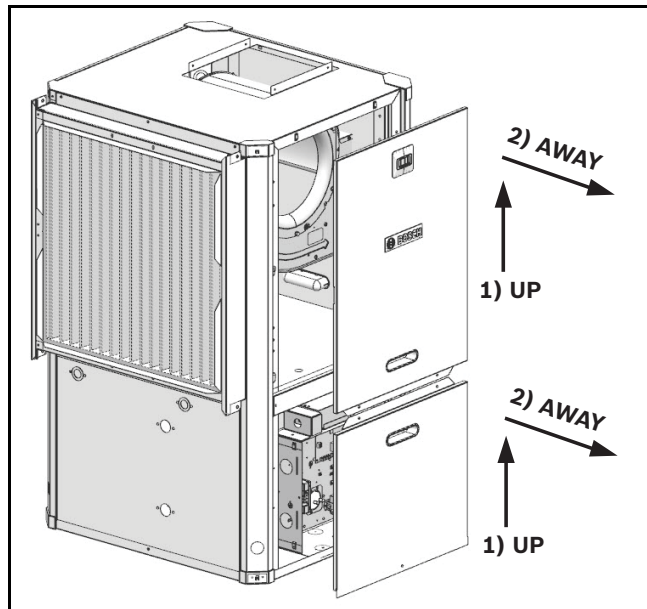

Figure # 46

4. Repeat steps 1–3 for all three sides.

Blower Re-Configuration



This instruction details re-configuration of blower from UP to SIDE discharge. Re-configuration to other side uses similar steps.

1. Remove and retain diagonal support brackets on Front and Back sides of the unit. (Figure #47)

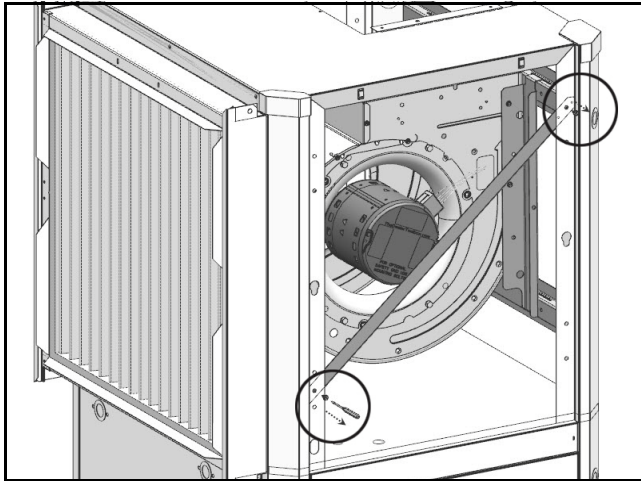

Figure # 47

2. Unplug electrical connections of Blower motor and ground wire connected to blower housing. (Figure #48)

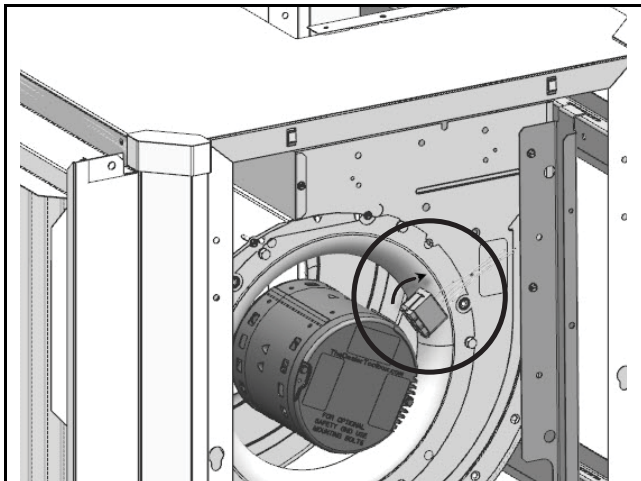

Figure # 48

3. Remove and retain blower motor and inlet ring assembly by removing (3) bolts securing blower motor bracket and screws securing the blower inlet ring. (Figure #49)



Removing the blower motor and blower wheel greatly simplifies handling of the blower assembly and reduces the chance of damaging heat pump components.

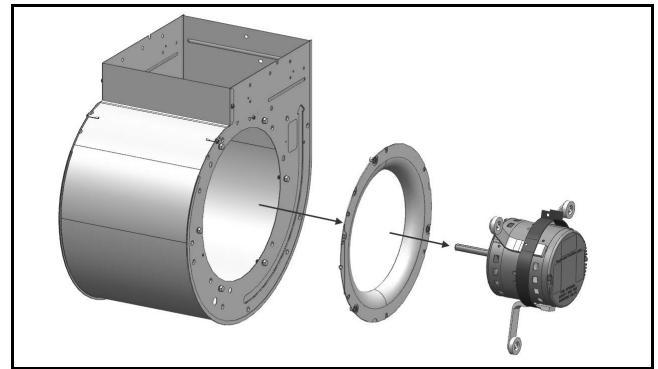

Figure # 49

4. Remove screws on both sides of the blower securing vertical blower bracket to horizontal support. (Figure#50)

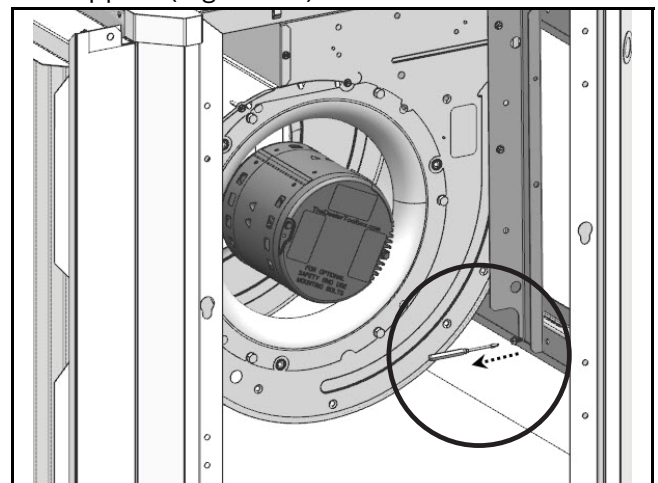

Figure # 50

5. Remove and retain blower assembly by lifting up. (Figure #51)



Air coil is in close proximity to the blower and air coil fins are easily damaged. Great care must be taken during this step to avoid coil damage. Shipping cardboard can be used as protection during blower removal and installation.

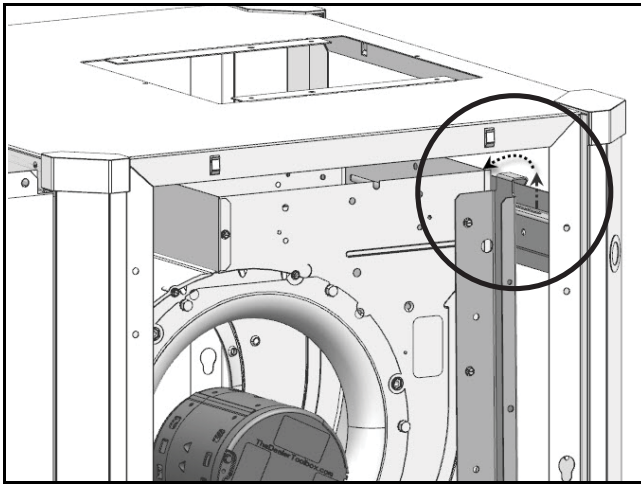

Figure # 51

6. Remove and discard blower collar. (Figure #52)



Discharge air configuration change is not possible on Heat Pumps equipped with Electric Heat Option.

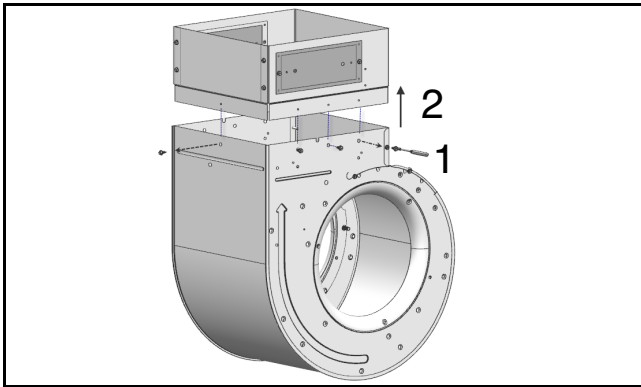

Figure # 52

7. Remove and retain side panel blower opening cover by removing (6) phillips head screws and cutting/tearing insulation at perforations around the perimeter of cover. (Figures #53 and #54)

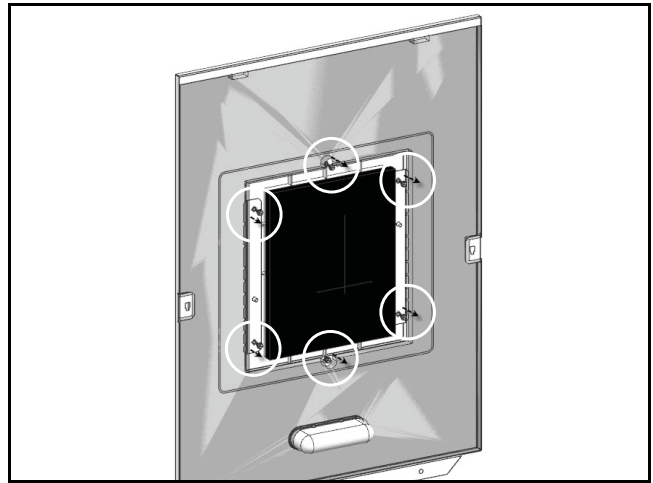

Figure # 53

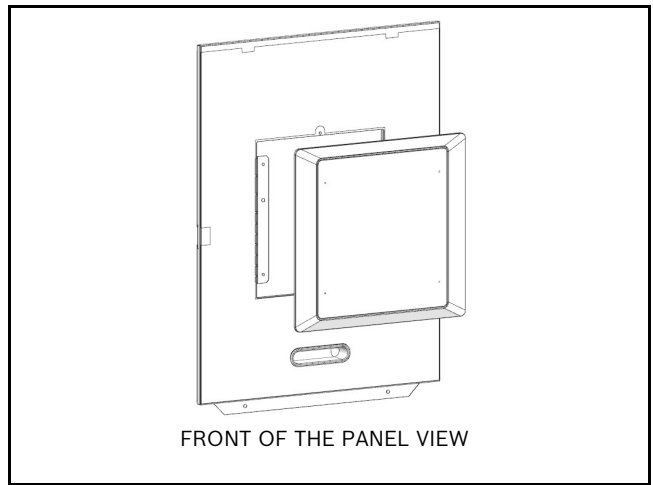

Figure # 54

8. Reinstall blower opening cover in the TOP panel. (Figure #55)

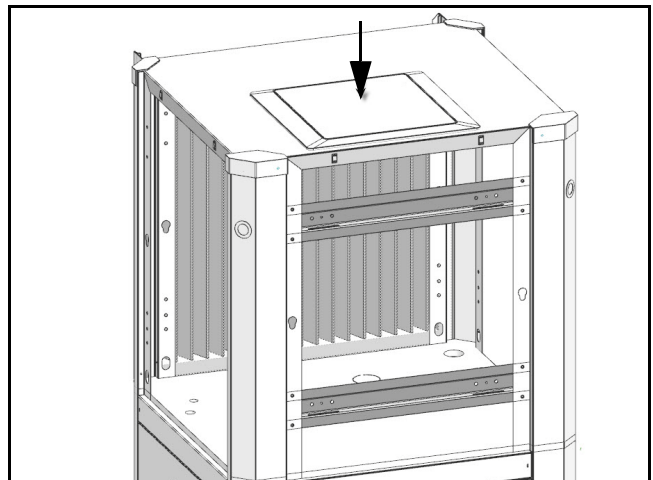

Figure # 55

- Remove and retain (2) horizontal blower support brackets by removing (4) screws in each. (Figure #56)

i Upper bracket contains two push-in rubber bump stops.

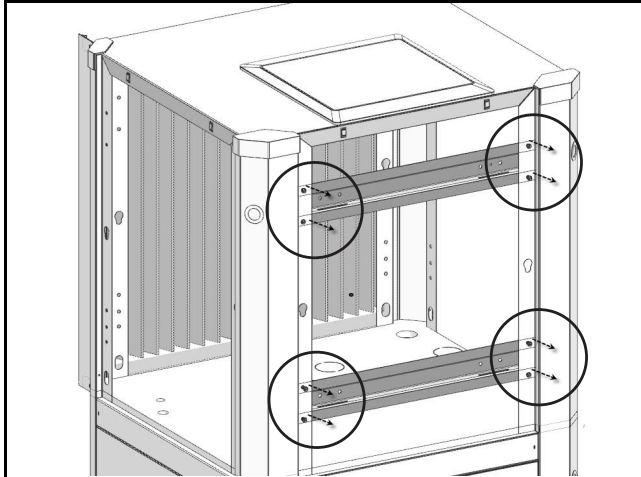

Figure # 56

- Reinstall brackets removed in Step (9) on the same side of the unit as the blower outlet. (Figure #57)

i Ensure bracket with push-in rubber bump stops is installed in the top position.

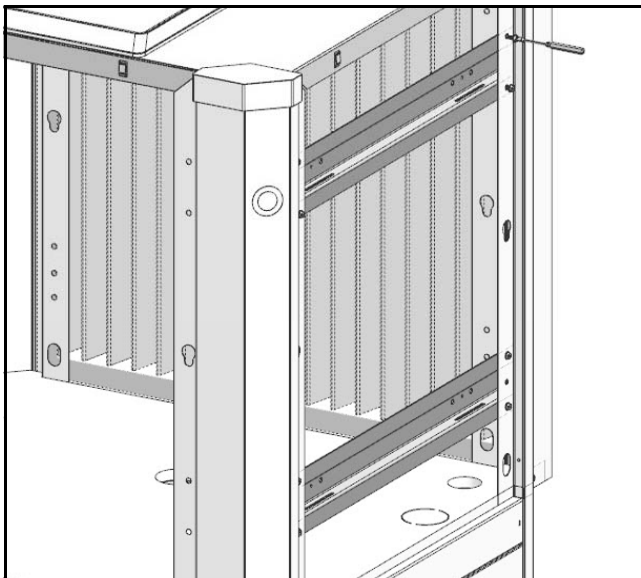

Figure # 57

- Remove and retain vertical brackets from blower by removing (4) screws, (2) on each side of the blower. (Figure #58)

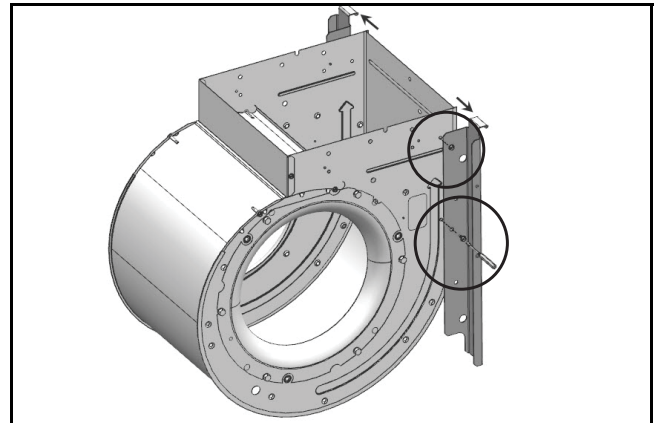

Figure # 58

- Reinstall vertical brackets in new orientation. (Figure #59)

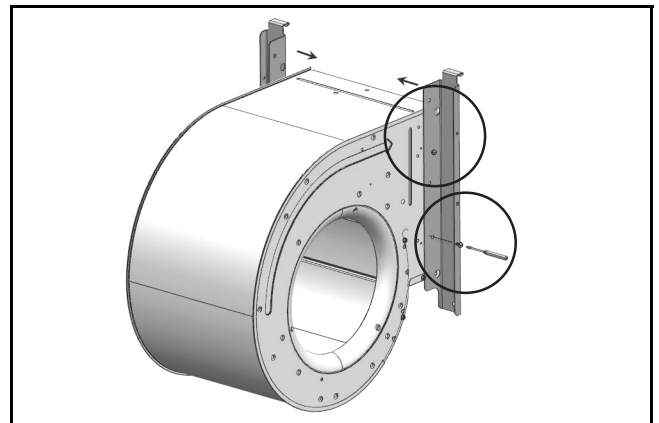

Figure # 59

- Reinstall the blower assembly in the new desired location, using the existing holes. (Figure #60)



NOTE: Be aware of blower housing proximity to air side coil and potential for coil damage.

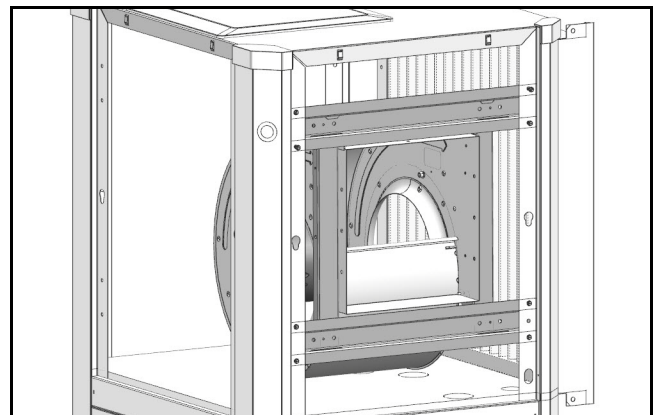

Figure # 60

14. Reinstall blower motor and inlet ring assembly by reversing Step #6. (Figure #61)

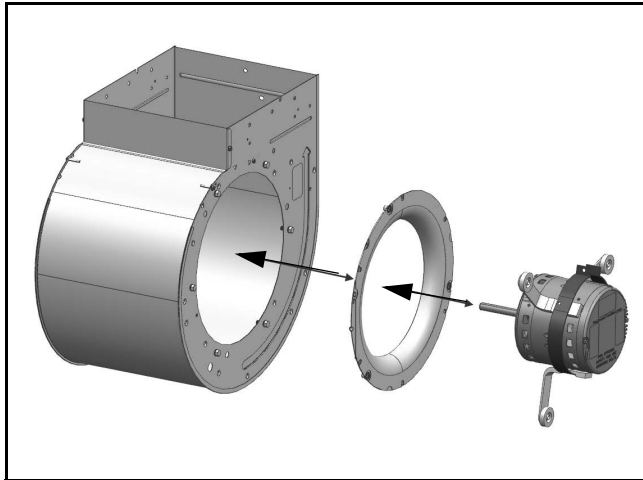

Figure # 61

15. Reconnect blower motor electrical plug and ground wire.
16. Reinstall diagonal bracket(s). (Figure #62)

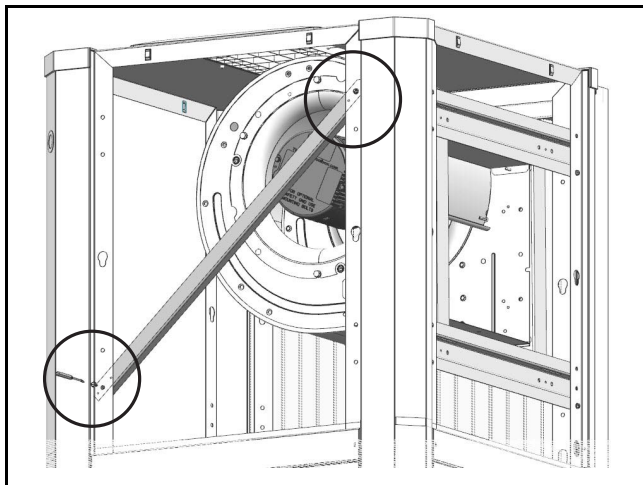

Figure # 62

Condensate Drain Connection Re-configuration

When re-configuring the unit from Left-Hand Return to Right-Hand Return it is necessary to relocate condensate drain connection from FRONT left corner post to BACK left corner post. (Figure#63)

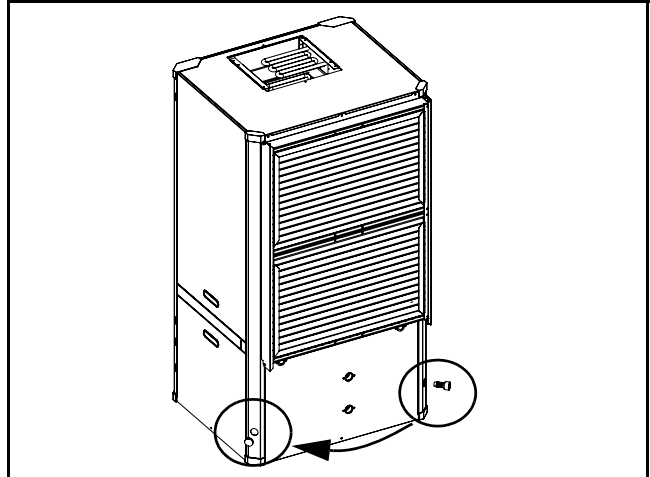

Figure # 63

1. Cut the condensate drain hose on the inside of cabinet.



Be sure to retain the spring

2. Remove and retain condensate drain plastic fitting and grommet from the hose by pulling it away from the hose (barb style connection). (Figure#64)

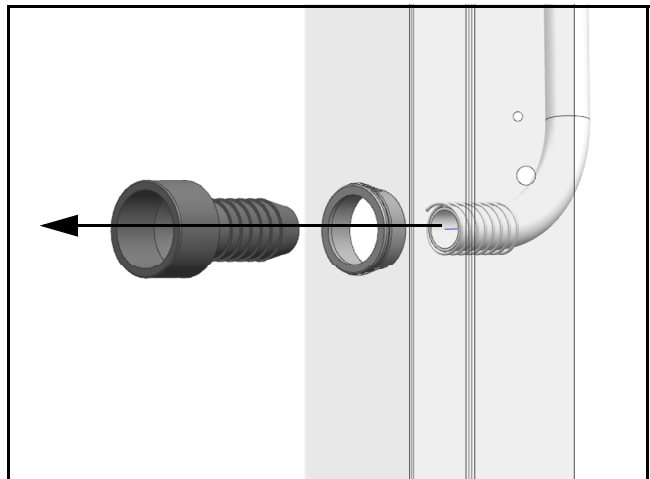

Figure # 64

3. Locate the BACK left condensate drain and remove and retain plastic plug covering the cutout. (Figure#65)

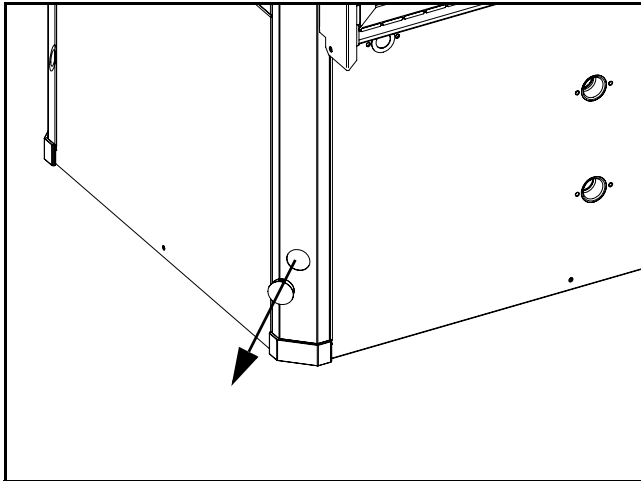

Figure # 65

4. Reinstall the removed plastic plugs in the original Condensate Drain Location.
5. Route the flexible plastic tube from FRONT left corner post to BACK left. (Figure#66)



NOTE: Avoid kinking the hose and/or creating a dip which could act as a second internal p-trap. Double trapped drain lines will not drain properly.

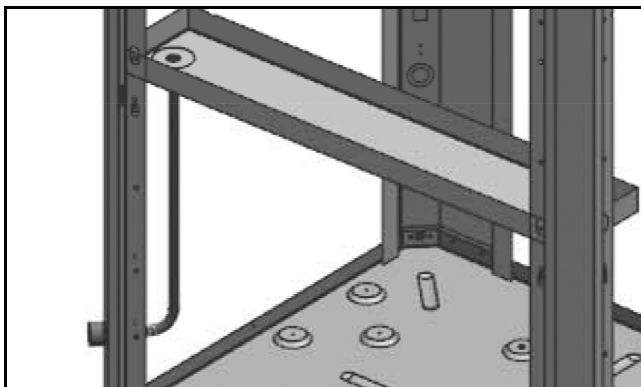

Figure # 66

6. Measure and cut the condensate drain hose to the appropriate length.
7. Insert spring onto condensate drain hose.

8. Reinstall condensate drain plastic fitting and bushing in its new location. (Figure#67)

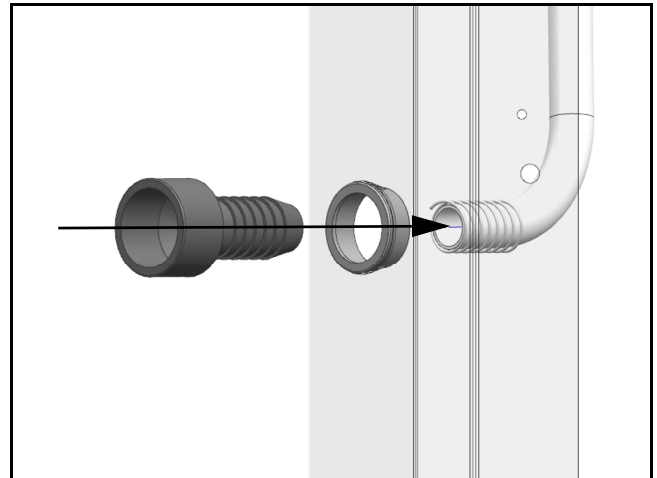

Figure # 67

HRP Switch Relocation

The HRP Pump Disconnect Switch is shipped loose inside unit E-Box, to be connected to either FRONT right corner post or BACK right corner post. (Figure#68)

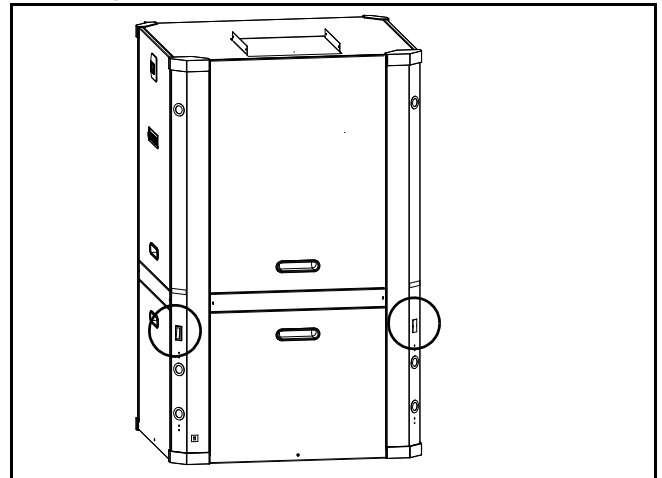

Figure # 68

1. From the inside of the unit remove (2) wires connected to HRP Pump Disconnect Switch.

2. Identify a rectangular knockout and remove it. Along with insulation.(Figure#69)

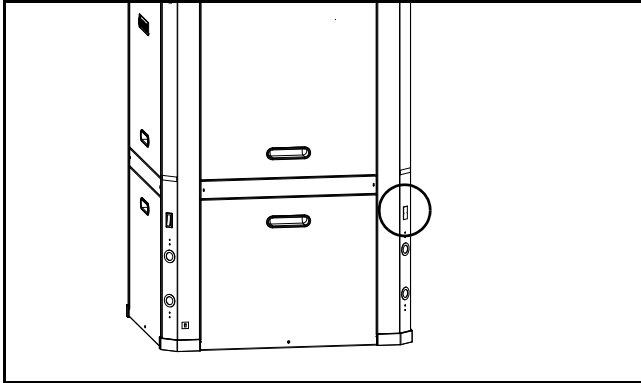



Figure # 69

3. Route HRP Pump Disconnect switch wires to the new switch location.

 **NOTE:** Do not route wiring over potentially hot surfaces or exposed sharp edges. Damage to wiring could result.

4. Install HRP Switch.
5. Reconnect the Switch wires.

Electric Heat Relocation

When changing the unit from Left-Hand Return to Right-Hand Return, it's required to relocate Electric Heat Components to the opposite side of the blower in order to allow field servicing.

 Electric Heat comes with (1) or (2) heating element inserts, depending on capacity. This instruction shows (1) heating element insert. Perform the same steps for the second insert, if present.

1. Identify Electric Heat components. (Figure#70)

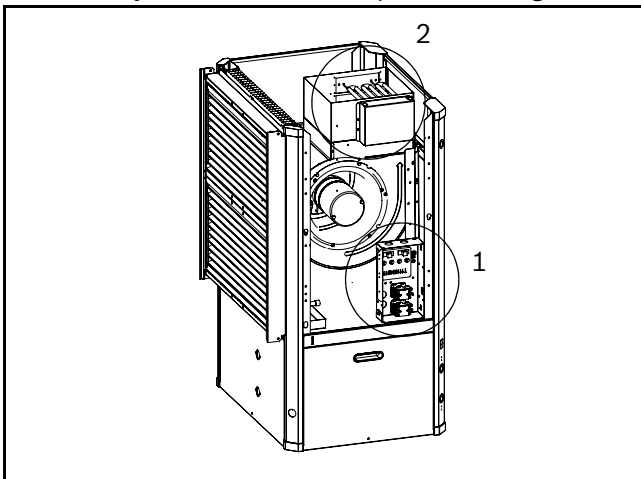

Figure # 70

- [1] Electric Heat Electrical Box
- [2] Electric Heat Elements.

2. Remove and retain the Electric Heat Element cover(s) by removing (4) screws in each.(Figure#71)

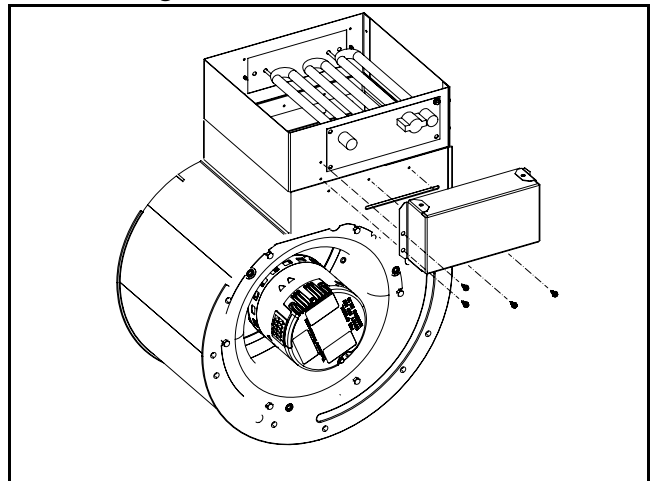

Figure # 71

3. Disconnect high voltage wiring a the Electric Heat Elements. (Figure#72)

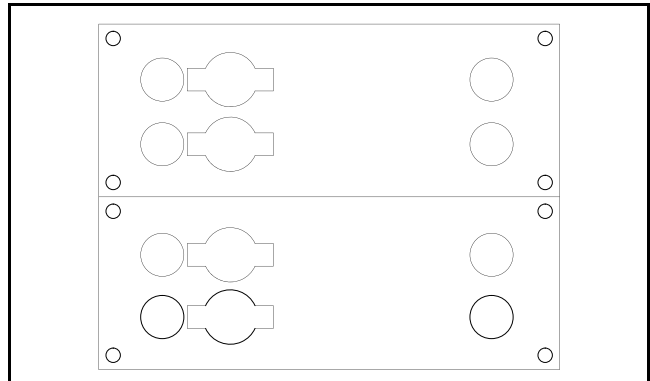

Figure # 72

4. Remove and retain Electric Heat Element(s).(Figure#73)

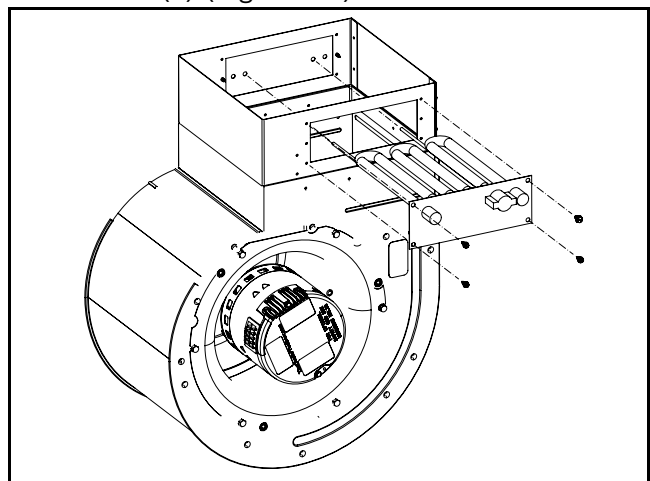

Figure # 73

5. Disconnect main Electric Heat E-box plug.(Figure#74)

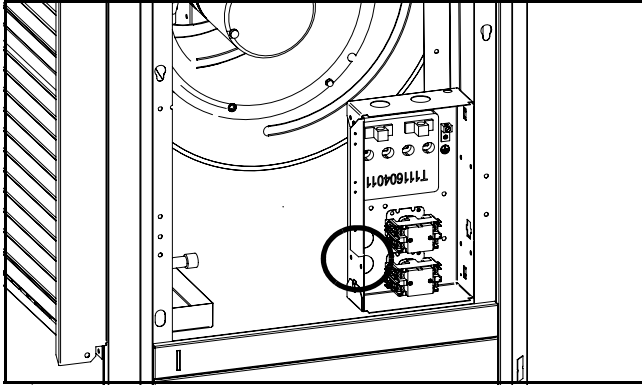

Figure # 74

6. Remove and retain Electric Heat E-box by removing (2) screws.(Figure#75)

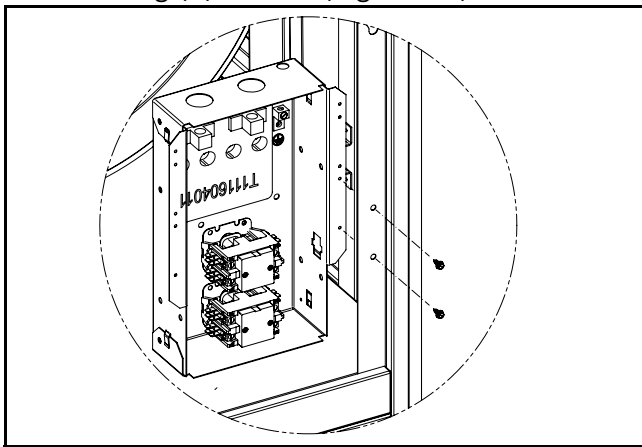

Figure # 75

7. Re-install Electric Heat E-box in the new location. (Figure#76)

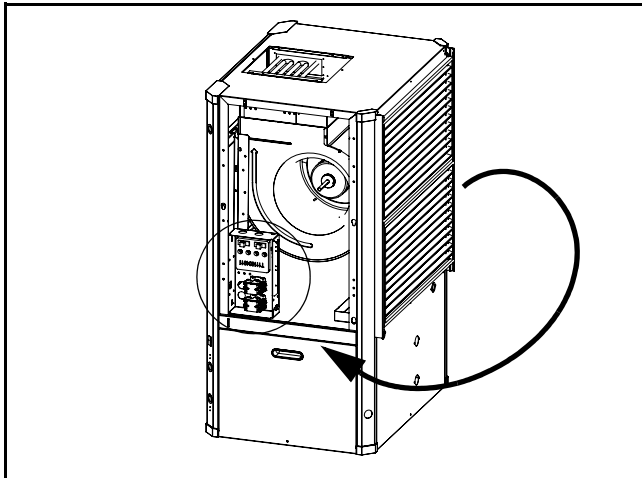

Figure # 76

8. Remove and retain Blower collar cover(s). (Figure#77)

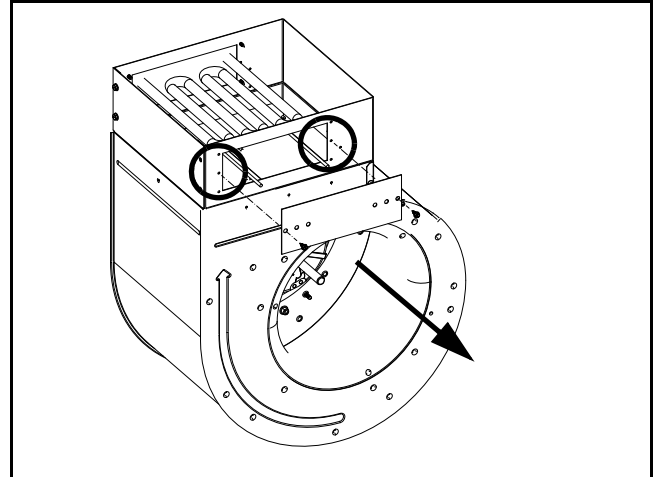

Figure # 77

9. Re-install Electric Heat Elements in the new location. Ensure High Temperature Cutouts are located on the left side. (Figure#78)

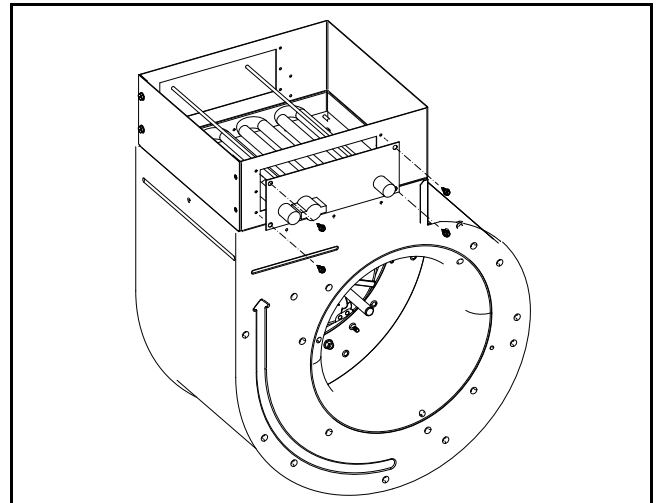

Figure # 78

10. Route the Unit E-box to Electric Heat wiring harness to the new Electric Heat Element location.

11. Connect wiring harness to the connector on the side of Electric Heat E-Box. (Figure#79)

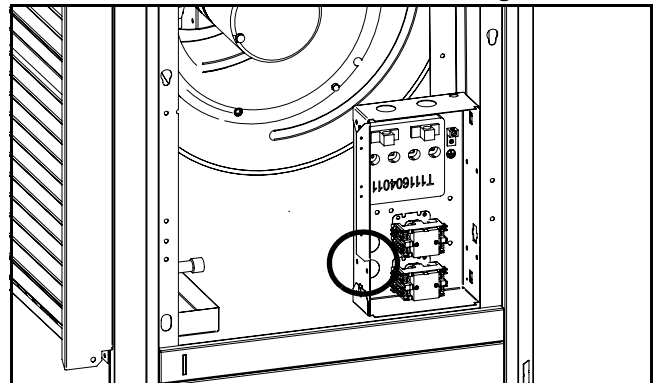

Figure # 79

12. Reconnect high voltage wiring from Electric Heat E-Box and Heating Element(s) matching wire number to terminals as shown.(Figure#80)

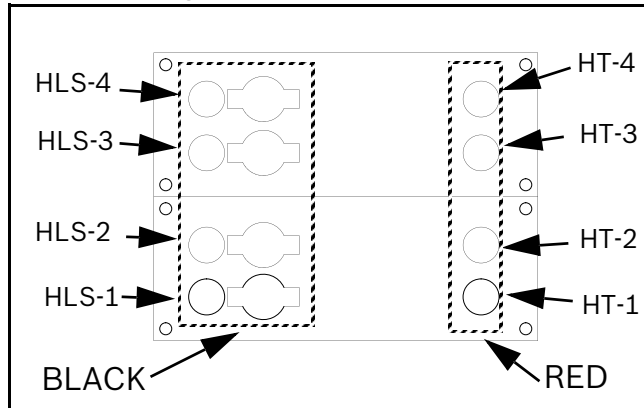

Figure # 80

13. Re-install Electric Heat Elements Cover(s). (Figure#81)

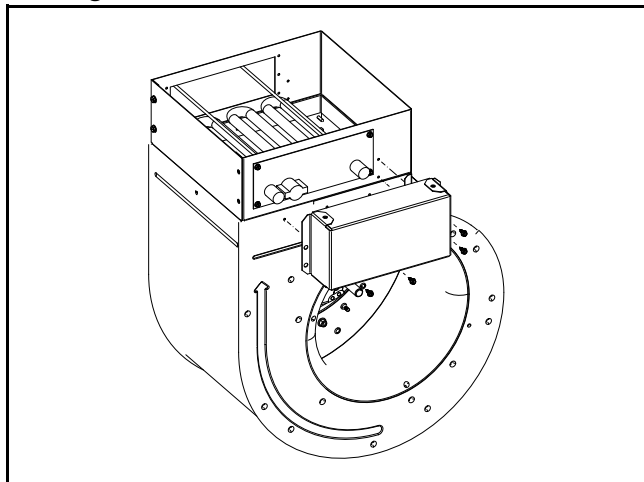

Figure # 81

Electrical Box re-configuration

E-box is designed to be removable to support field configuration of unit: Left-Hand Return and Right-Hand Return, and also to allow full access to compressor during servicing.

The Electrical box (E-Box) has a set of plugs that allows complete removal from the system while keeping the majority of its internal connections. (Figure#123 & #124, Pg#72 and Pg#73)

1. Disconnect wiring harness by unplugging the following plugs: P18, P19, P20 and P23 (P12 if unit is equipped with Electric Heat). (Figure#123 & #124, Pg#72 and Pg#73)
2. Disconnect compressor plugs at compressor.
3. Remove and retain Electric Box by removing (2) screws. (Figure #82)



CAUTION: take great care to ensure all wires are disconnected and none of the wires are 'snagged' on any components

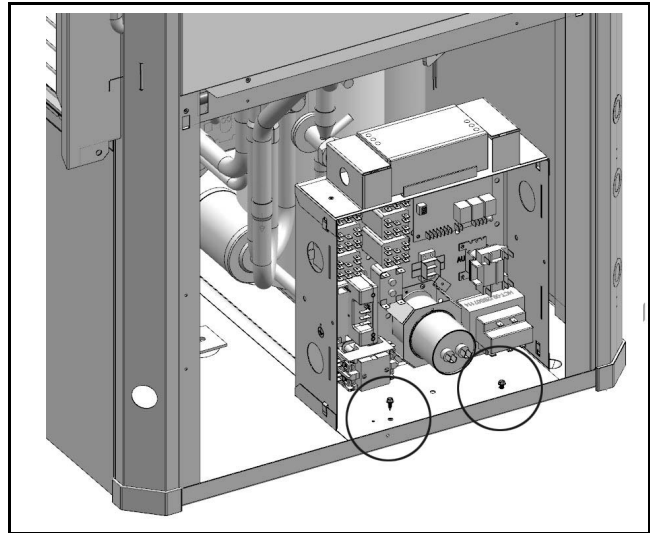

Figure # 82

4. Reroute all of the disconnected wire bundles to the opposite side of the heat pump.



NOTE: Do not route wiring over potentially hot surfaces or exposed sharp edges. Damage to wiring could result.

5. Install E-box in its new location by installing (2) screws. (Figure #83)

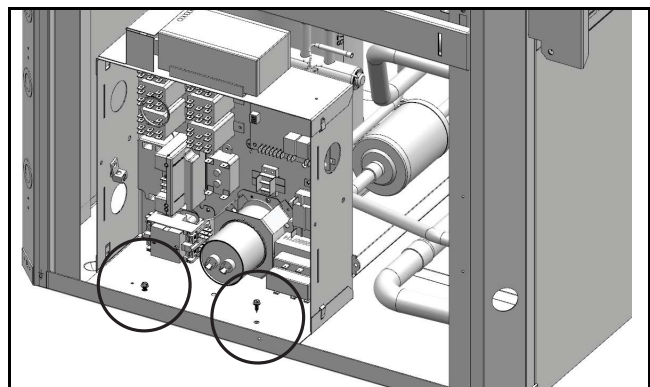

Figure # 83

6. Reconnect all the wiring disconnected in Step #1.



NOTE: Ensure all connectors are properly oriented and are fully engaged.

7. Identify and re-route LCD wiring harness to the new location.



Panel containing LCD always mounts on the same side as E-Box.

8. Swap FRONT panel (containing LCD) to the BACK

Reinstall All Panels

1. Re-route the LCD wiring to the new location and reconnect LCD screen wiring. Reinstall panels. (Figure #84)



Panel containing LCD and Bosch Logo must be installed on the same side as Electrical Box.



Bend flanges one at a time.

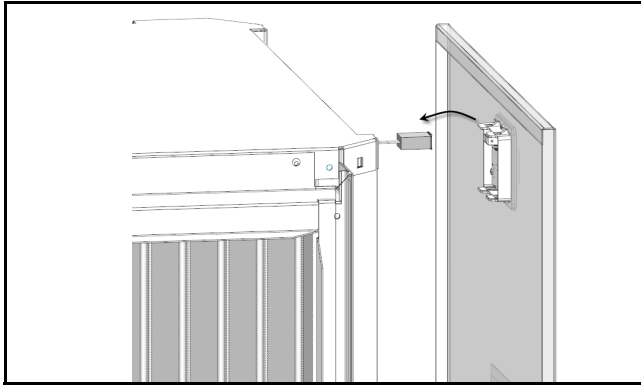
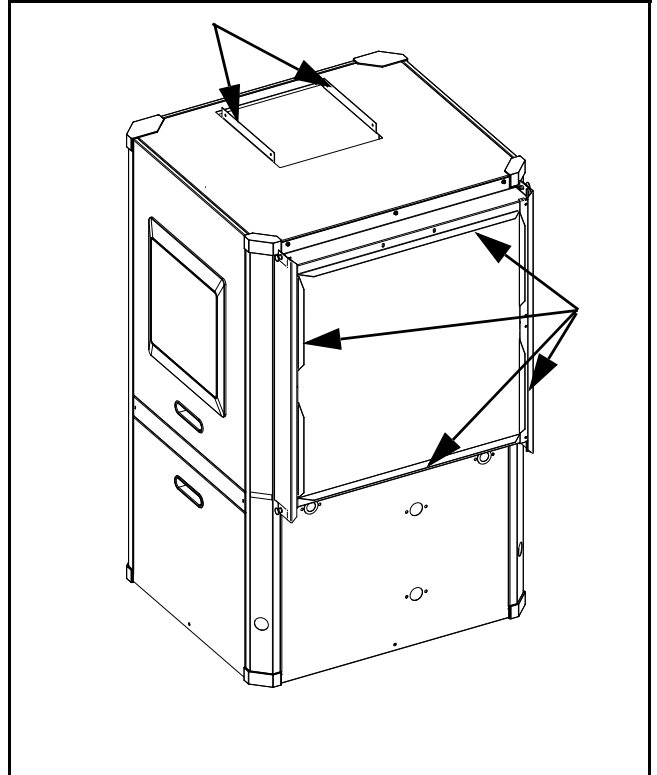

Figure # 84



NOTE: When re-installing panel, the “RED” cable from the LCD connector must be connected to the “R” terminal of the LCD PCB. The LCD will not work any other way.



2. Reinstall belts. (Figure#85)

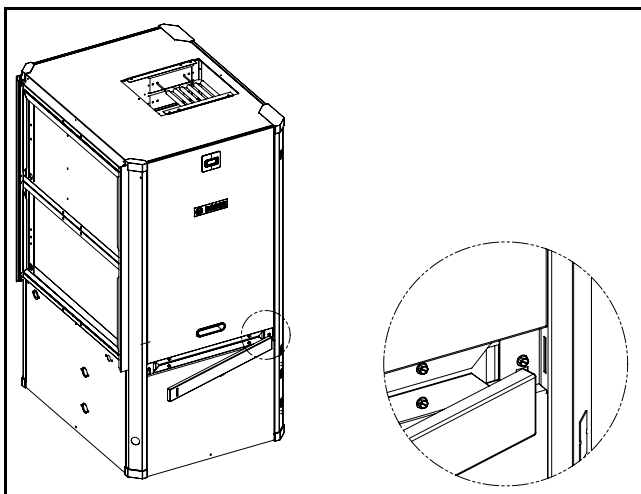

Figure # 85

PRE INSTALLATION UNIT PREPARATION

Corner Cap Installation Instructions

Each corner cap is stamped with one the following identifiers: T, T1, T2 B, B1, B2, A.

1. Identify Letter code on each Corner Cap. (Figure#86)

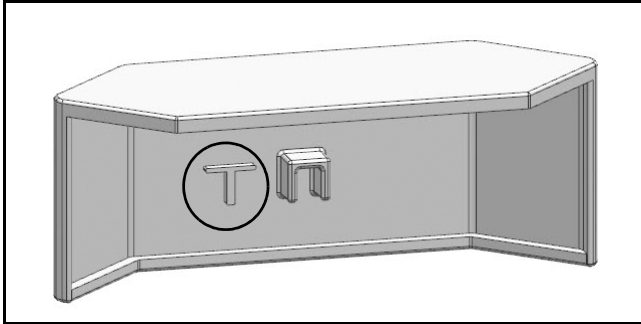

Figure # 86

2. In preparation for installation identify each Corner Cap location. (VT & CF Figure#87 and HZ Figure#88)

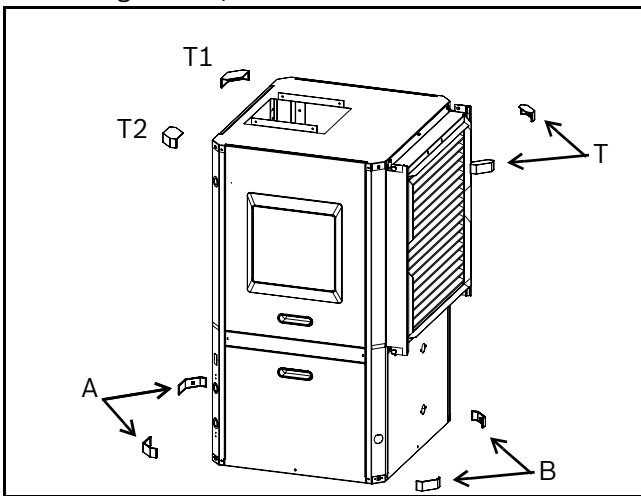

Figure # 87

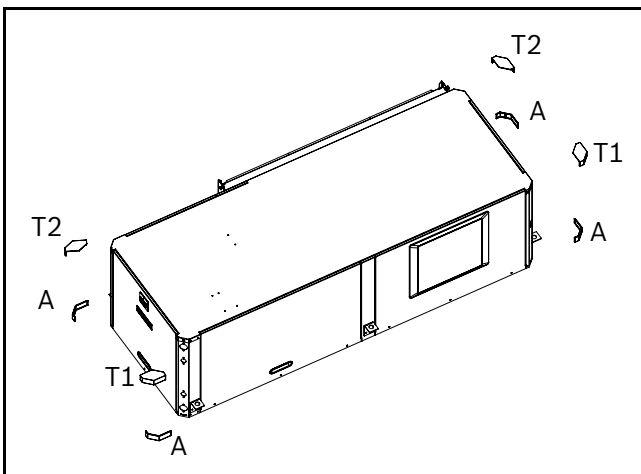

Figure # 88

3. Remove adhesive backing and install each Corner Cap. (Figure#89 and#90)



Ensure cabinet surface is clean and free of debris to ensure proper Corner Cap Adhesion.

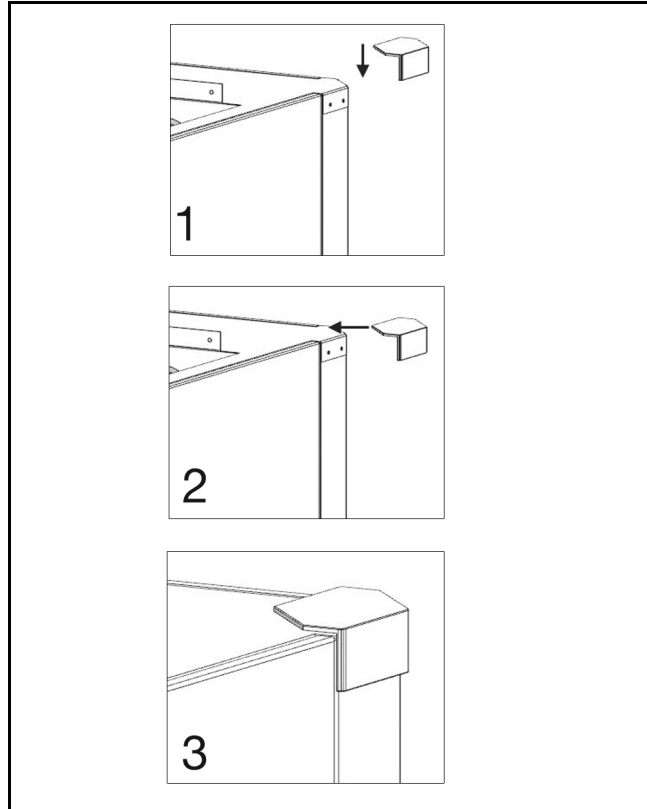

Figure # 89

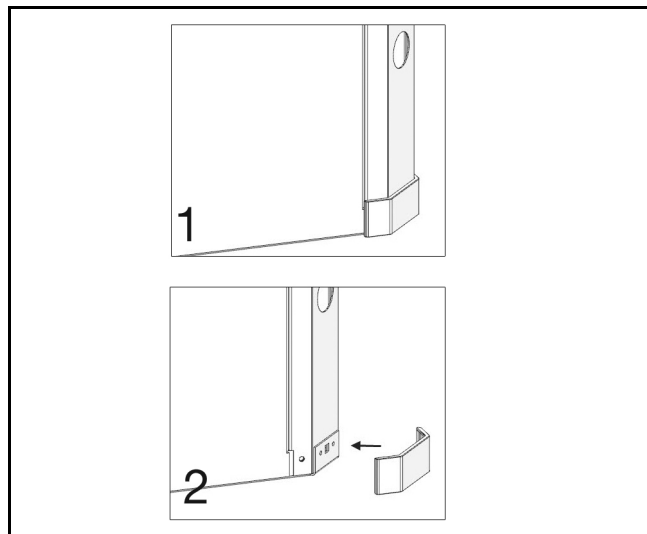

Figure # 90

MOUNTING VERTICAL UNITS

Vertical units should be mounted level on a vibration absorbing pad slightly larger than the base to minimize vibration transmission to the building structure. It is not necessary to anchor the unit to the floor. (Figure #91).



On VT and CF Units Condensate Drain pan is internally sloped. There is no internal P-Trap.

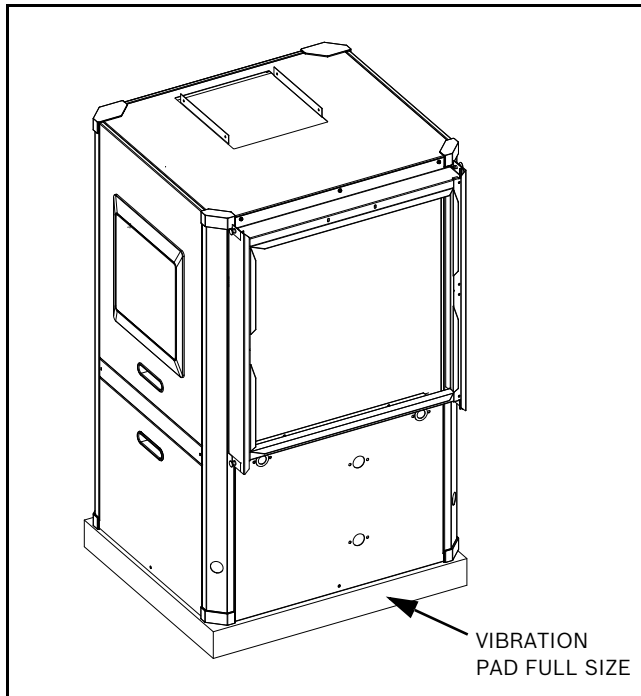

Figure # 91

MOUNTING HORIZONTAL UNITS

While horizontal units may be installed on any level surface strong enough to hold their weight, they are typically suspended above a ceiling by threaded rods. The manufacturer recommends these be attached to the unit corners by hanger bracket kits. The rods must be securely anchored to the ceiling. Refer to the hanging bracket assembly and installation instructions for details.



WARNING: Horizontal units installed above the ceiling must conform to all local codes. An auxiliary drain pan if required by code, should be at least four inches larger than the bottom of the heat pump.

Plumbing connected to the heat pump must not come in direct contact with joists, trusses, walls, etc. Some applications require an attic floor installation of the horizontal unit. In this case the unit should be set in a full size secondary drain pan on top of a vibration absorbing mesh.

The secondary drain pan prevents possible condensate overflow or water leakage damage to the ceiling.

The secondary drain pan is usually placed on a plywood base isolated from the ceiling joists by additional layers of vibration absorbing mesh. In both cases, a 3/4" drain connected to this secondary pan should be run to an eave at a location that will be noticeable.

If the unit is located in a crawl space, the bottom of the unit must be at least 4" above grade to prevent flooding of the electrical parts due to heavy rains.



HZ Units Condensate Drain pan is NOT internally sloped.



NOTE: Horizontal (HZ) units must be installed pitched toward the Condensate Drain Connection 1/8" per foot.

HANGING BRACKET KIT

Installation Instructions

All horizontal units come with hanging bracket installation kit to facilitate suspended unit mounting using threaded rod. Hanging brackets are to be installed as shown in Figure #92.

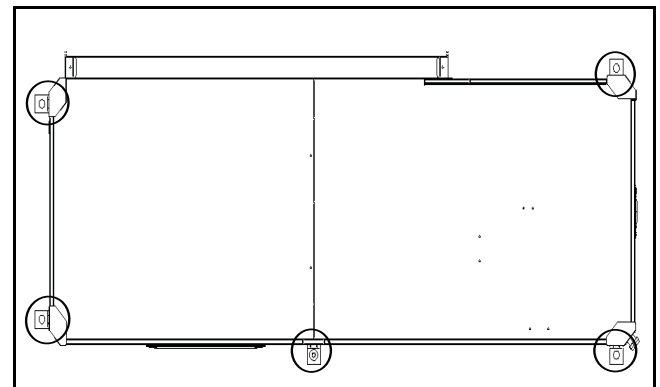

Figure # 92

This kit includes the following:

- (5) Brackets
- (5) Rubber Vibration isolators
- (8) Screws #10x1/2 (not used for these models)
- (10) Bolts 1/4-28x12" Hex bolt

The following are needed and are to be field provided:

- Threaded rod (3/8" max dia)
- Hex nuts
- Washers (1-3/4" min O.D.)

1. Remove and discard factory provided screws from locations where hanging brackets will be installed shown in Figure #93

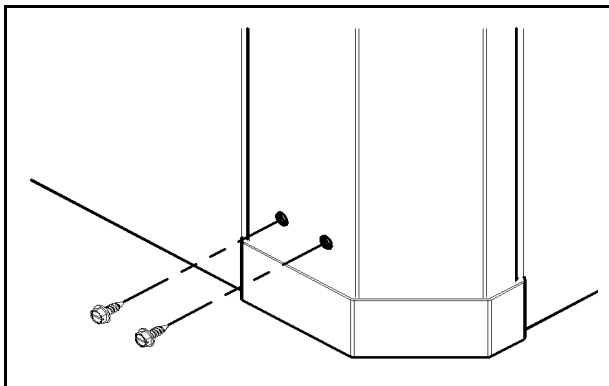

Figure # 93

2. Mount 5 brackets to unit corner post using the Bolts provided in the kit as shown on Figure # 94



WARNING: Do not re-use screws removed from the unit on step 1 to mount the hanging brackets to the unit.

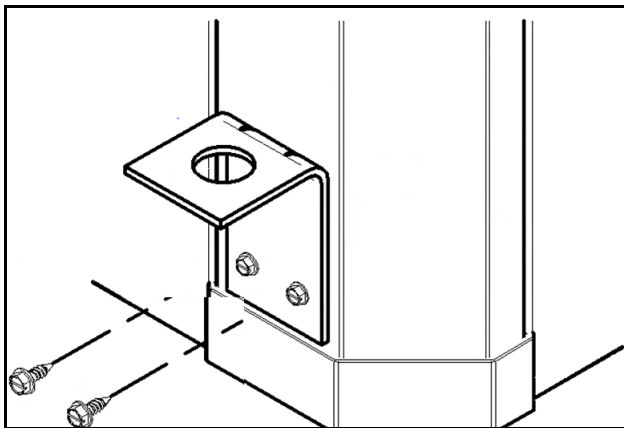

Figure # 94



WARNING: Follow all applicable codes and requirements when hanging this unit, selecting threaded rod material, etc.

3. Install rubber grommet onto the brackets as shown in Figure # 95

4. Hang the unit and assemble the field provided Thread rod, nuts and washers on to the brackets as shown in Figure # 95



WARNING: Rods must be securely anchored to the ceiling

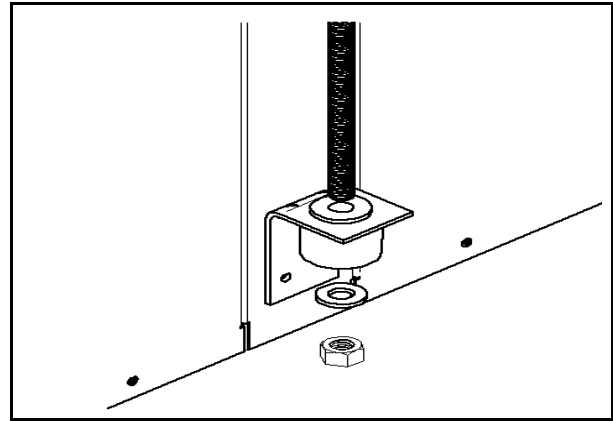

Figure # 95

CONDENSATE DRAIN

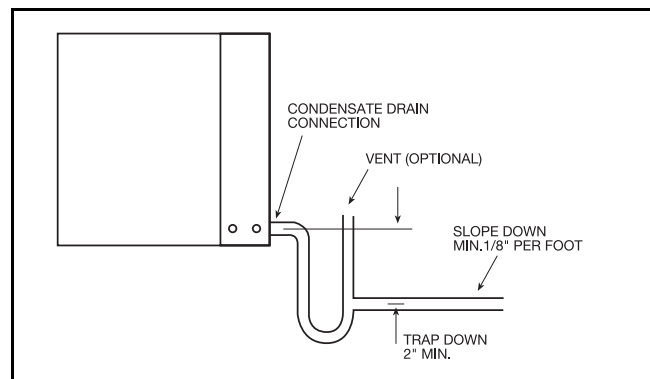

Figure # 96

A drain line must be connected to the heat pump and pitched away from the unit a minimum of 1/8" per foot to allow the condensate to flow away from the unit.



When converting unit from left-hand return to right-hand return, condensate drain connection must be relocated. Refer to Pg#20.

This connection must be in conformance with local plumbing codes. A trap must be installed in the condensate line to insure free condensate flow.



HZ Heat Pump Drain Pan is not internally sloped.

A vertical air vent is sometimes required to avoid air pockets. The length of the trap depends on the amount of positive or negative pressure on the drain pan. A second trap must not be included.

DUCT SYSTEM

A supply air outlet collar and return air duct flange are provided on all units to facilitate duct connections.



Supply air duct and return air duct flanges are shipped unfolded with unit.

Fold the duct flange outwards along the perforated line. Refer to unit Dimensional Drawings for physical dimensions of the collar and flange. (Pg#95 through Pg#95)

A flexible connector is recommended for supply and return air duct connections on metal duct systems. All metal ducting should be insulated with a minimum of one inch duct insulation to avoid heat loss or gain and prevent condensate forming during the cooling operation. Application of the unit to the no insulated duct work is not recommended as the unit's performance will be adversely affected.



NOTE: Do not connect discharge ducts directly to the blower outlet.

The factory provided air filter must be removed when using a filter back return air grill. The factory filter should be left in place on a free return system.

If the unit will be installed in a new installation which includes new duct work, the installation should be designed using current ASHRAE procedures for duct sizing. If the unit is to be connected to existing duct work, a check should be made to assure that the duct system has the capacity to handle the air required for the unit application. If the duct system is too small, larger duct work should be installed. Check for existing leaks and repair.

The duct system and all diffusers should be sized to handle the designed air flow quietly. To maximize sound attenuation of the unit blower, the supply and return air plenums should be insulated. There should be no direct straight air path thru the return air grille into the heat pump. The return air inlet to the heat pump must have at least one 90 degree turn away from the space return air grille. If air noise or excessive air flow are a problem, the blower speed can be changed to a lower speed to reduce air flow.

PIPING

Supply and return piping must be as large as the unit connections on the heat pump (larger on long runs).



NOTE: Never use flexible hoses of a smaller inside diameter than that of the fluid connections on the unit.

SM units are supplied with either a copper or optional cupro-nickel condenser. Copper is adequate for ground water that is not high in mineral content.



Proper testing is recommended to assure the well water quality is suitable for use with water source equipment. When in doubt, use cupro-nickel.

In conditions anticipating moderate scale formation or in brackish water a cupro-nickel heat exchanger is recommended.

Refer to water quality table on page #30

Both the supply and discharge water lines will sweat if subjected to low water temperature. These lines should be insulated to prevent damage from condensation. All manual flow valves used in the system must be ball valves. Globe and gate valves must not be used due to high pressure drop and poor throttling characteristics.



NOTE: Never exceed the recommended water flow rates as serious damage or erosion of the water-to-refrigerant heat exchanger could occur.

Always check carefully for water leaks and repair appropriately. Units are equipped with swivel female pipe thread fittings. Consult Unit Dimensional Drawings. (Pg#95 through Pg#95)



Teflon tape sealer should be used when connecting water piping connections to the units to insure against leaks and possible heat exchanger fouling.



NOTE: Do not overtighten the connections.

Flexible hoses should be used between the unit and the rigid system to avoid possible vibration. Ball valves should be installed in the supply and return lines for unit isolation and unit water flow balancing.

WATER QUALITY

Table 1: Water Quality			
POTENTIAL PROBLEM	Water Characteristic	Acceptable Value	
		Copper	Cupro-Nickel
	pH (Acidity/Alkalinity)	7-9	7-9
SCALING	Hardness (CaCO ₃ , MgCO ₃)	< 350 ppm	< 350 ppm
	Ryznar Stability Index	6.0 - 7.5	6.0 - 7.5
	Langelier Saturation Index	-0.5 - +0.5	-0.5 - +0.5
CORROSION	Hydrogen Sulfide (H ₂ S)	< 0.5 ppm *	10-50 ppm
	Sulfates	< 125 ppm	< 125 ppm
	Chlorine	< 0.5 ppm	< 0.5 ppm
	Chlorides	< 20 ppm	< 150 ppm
	Carbon Dioxide	< 50 ppm	< 50 ppm
	Ammonia	< 2 ppm	< 2 ppm
	Ammonia Chloride	< 0.5 ppm	< 0.5 ppm
	Ammonia Nitrate	< 0.5 ppm	< 0.5 ppm
	Ammonia Hydroxide	< 0.5 ppm	< 0.5 ppm
	Ammonia Sulfate	< 0.5 ppm	< 0.5 ppm
	Dissolved Solids	< 1,000 ppm	< 1,500 ppm
IRON FOULING	Iron (Fe ²⁺ Iron Bacteria Potential)	< 0.2 ppm	< 0.2 ppm
	Iron Oxide	< 1 ppm	< 1 ppm
EROSION	Suspended Solids	< 10 ppm, < 600 µm size **	< 10 ppm, < 600 µm size **
	Maximum Water Velocity	6 ft/sec	6 ft/sec

* No "rotten egg" smell present at < 0.5 ppm H₂S.

** Equivalent to 30 mesh strainer

ELECTRICAL

Refer to electrical component box layout.
(Figure #97)



WARNING: Field wiring must comply with local and national electric codes.



WARNING: Power to the unit must be within the operating voltage range indicated on the unit nameplate or on the performance data sheet.



NOTE: Operation of unit on improper line voltage or with excessive phase imbalance will be hazardous to the unit, constitutes abuse and may void the warranty.

Properly sized fuses or HACR circuit breakers must be installed for branch circuit protection. See unit nameplate for maximum fuse or breaker size.

The unit is provided with a concentric knock-out for attaching common trade sizes of conduit, route power supply wiring through this opening. Always connect the ground lead to the grounding lug provided in the control box and power leads to the line side of compressor contactor as indicated on the wiring diagram (Figures#113 through #117 Pg#65 through Pg#66).



Units supplied with internal electric heat require two (2) separate power supplies:

- 1) Unit compressor
- 2) Electric Heat, blower motor and control circuit.

Refer to the ELECTRIC HEATER PACKAGE OPTION section and Pg#65 through Pg#66 for wiring diagrams. See data plate for minimum circuit ampacities and maximum fuse/breaker sizing.

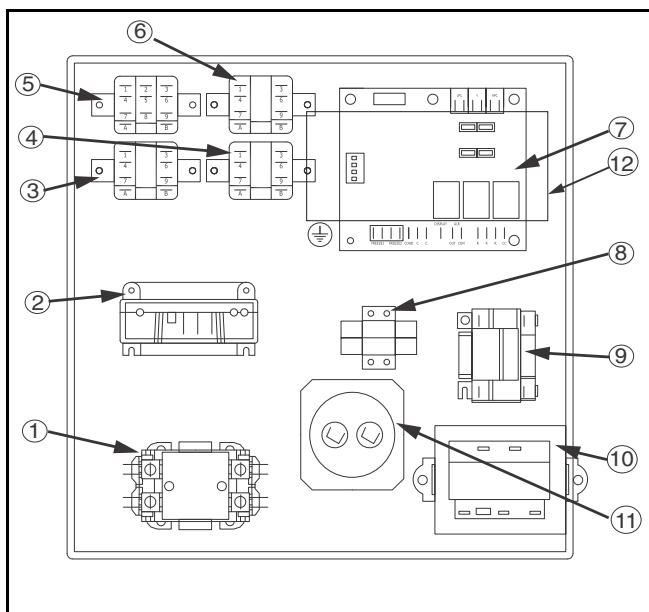

Figure # 97

- [1] Compressor contactor
- [2] Comfort Alert Module (Option)
- [3] Emergency Relay (Option)
- [4] Second Stage Relay
- [5] Hot Gas Reheat Relay (Option)
- [6] Cooling Relay
- [7] Unit Protection Module (UPM)
- [8] Terminal block (Option)
- [9] Auxiliary Relay (Option)
- [10] Transformer
- [11] Capacitor
- [12] ECM Module (Option, mounts on E-Box cover)

Safety Devices and the UPM Controller

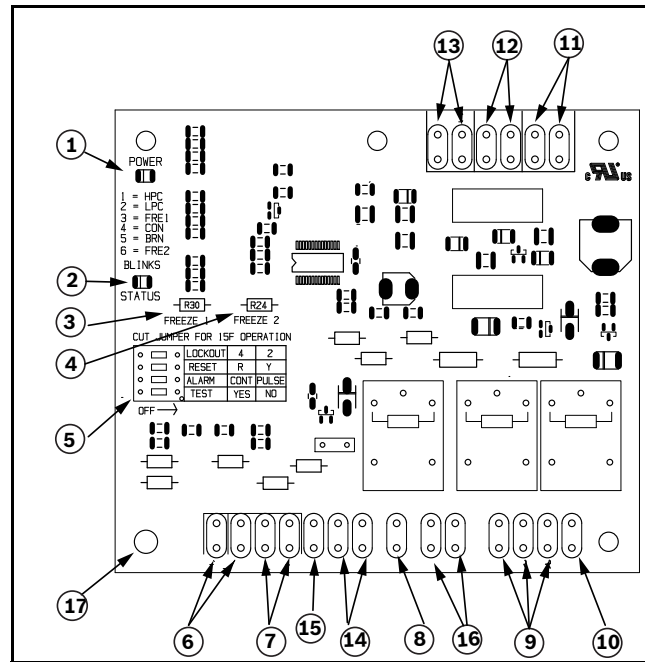

Figure # 98

- [1] Board Power Indicator
- [2] UPM Status LED Indicator
- [3] Water Coil Freeze Protection Temperature Selection [R30]
- [4] Air Coil Freeze Protection Temperature Selection
- [5] UPM Board Settings
- [6] Water Coil Freeze Connection (Freeze 1)
- [7] Air Coil Freeze Connection (Freeze 2)
- [8] LCD Unit Display Connection
- [9] 24VAC Power Input
- [10] Compressor Contact Output
- [11] High Pressure Switch Connection
- [12] Call for Compressor Y1
- [13] Low Pressure Switch Connection
- [14] 24VAC Power Common
- [15] Condensate Overflow Sensor
- [16] Dry Contact
- [17] UPM Ground Standoff



If the unit is being connected to a thermostat with a malfunction light, this connection is made at the unit malfunction output or relay. Refer to Figure #98



If the thermostat is provided with a malfunction light powered off of the common (C) side of the transformer, a jumper between “R” and “COM” terminal of “ALR” contacts must be made.



If the thermostat is provided with a malfunction light powered off of the hot (R) side of the transformer, then the thermostat malfunction light connection should be connected directly to the (ALR) contact on the unit’s UPM board.

Each unit is factory provided with a Unit Protection Module (UPM) that controls the compressor operation and monitors the safety controls that protect the unit.

Safety controls include the following:

- High pressure switch located in the refrigerant discharge line and wired across the HPC terminals on the UPM.
- Low pressure switch located in the unit refrigerant suction line and wired across terminals LPC1 and LPC2 on the UPM.



UPM Board Dry Contacts are Normally Open (NO)

- Water side freeze protection sensor, mounted close to condensing water coil, monitors refrigerant temperature between condensing water coil and thermal expansion valve. If temperature drops below or remains at freeze limit trip for 30 seconds, the controller will shut down the compressor and enter into a soft lockout condition. The default freeze limit trip is 26°F, however this can be changed to 15°F by cutting the R30 or Freeze1 resistor located on top of DIP switch SW1 (Refer to Figure #98, item [3] for resistor location), Refer to Figure #99 for sensor location.

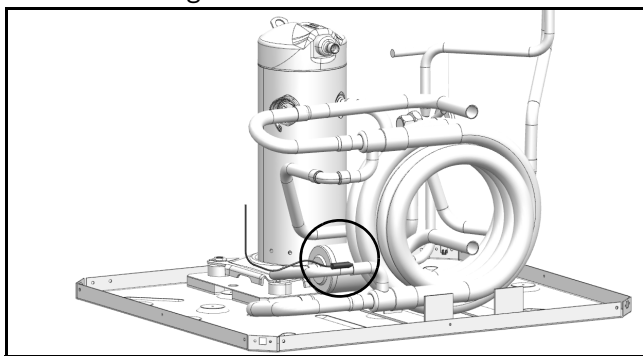

Figure # 99



NOTE: If unit is employing a fresh water system (no anti-freeze protection), it is extremely important to have the Freeze1 R30 resistor set to 26°F in order to shut down the unit at the appropriate leaving water temperature and protect your heat pump from freezing if a freeze sensor is included.

- Evaporator freeze protection sensor, mounted after the thermal expansion device and the evaporator, monitors refrigerant temperature between the evaporator coil and thermal expansion valve. If temperature drops below or remains at freeze limit trip for 30 seconds, the controller will shut down the compressor and enter into a soft lockout condition. The default freeze limit trip is 26°F. (Figure#100)

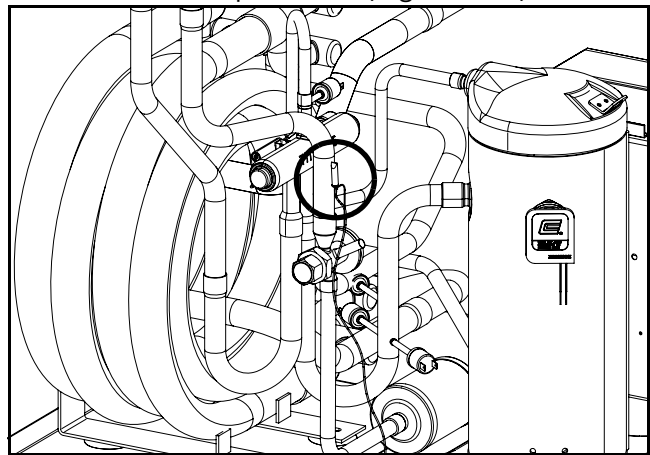

Figure # 100

- The condensate overflow protection sensor is located in the drain pan of the unit and connected to the ‘COND’ terminal on the UPM board. (Figure #101)

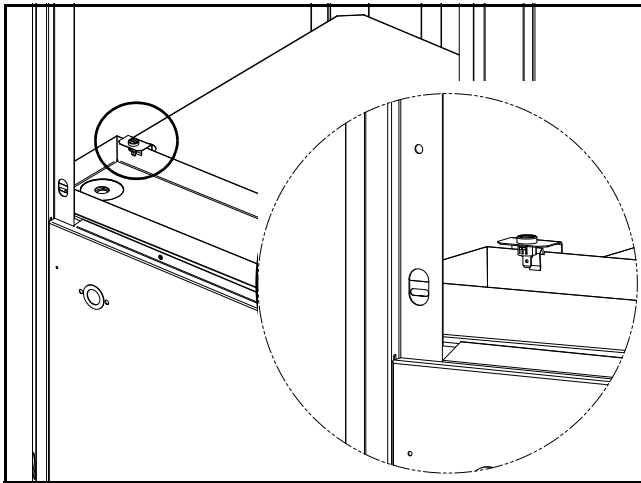

Figure # 101

UPM Board Factory Default Settings

TEMP	26°F
LOCKOUT	2
RESET	Y
ALARM	PULSE
TEST	NO

UPM DIP SWITCH DEFAULT POSITION

	lockout	4	2
	reset	R	Y
	alarm	Cont	pulse
	test	yes	no

The UPM Board includes the following features:

- **ANTI-SHORT CYCLE TIMER:** 5 minute delay on break timer to prevent compressor short cycling.
- **RANDOM START:** Each controller has an unique random start delay ranging from 270 to 300 seconds on initial power up to reduce the chance of multiple unit simultaneously starting at the same time after power up or after a power interruption, thus avoiding creating large electrical spike.

- **LOW PRESSURE BYPASS TIMER:** If the compressor is running and the low pressure switch opens, the controller will keep the compressor ON for 120 seconds. After 2 minutes if the low pressure switch remains open, the controllers will shut down the compressor and enter a soft lockout. The compressor will not be energized until the low pressure switch closes and the anti-short cycle time delay expires. If the low pressure switch opens 2-4 times in 1 hour, the unit will enter a hard lockout. In order to exit hard lockout power to the unit would need to be reset.
- **BROWNOUT/SURGE/POWER INTERRUPTION PROTECTION:** The brownout protection in the UPM board will shut does the compressor if the incoming power falls below 18 VAC. The compressor will remain OFF until the voltage is above 18 VAC and ANTI-SHORT CYCLE TIMER (300 seconds) times out. The unit will not go into a hard lockout.
- **MALFUNCTION OUTPUT:** Alarm output is Normally Open (NO) dry contact. If pulse is selected the alarm output will be pulsed. The fault output will depend on the dip switch setting for "ALARM". If it is set to "CONST", a constant signal will be produced to indicate a fault has occurred and the unit requires inspection to determine the type of fault. If it is set to "PULSE", a pulse signal is produced and a fault code is detected by a remote device indicating the fault. See L.E.D Fault Indication below for blink code explanation. The remote device must have a malfunction detection capability when the UPM board is set to "PULSE".



If 24 VAC output is needed, R must be wired to ALR-COM terminal; 24 VAC will be available o the ALR-OUT terminal when the unit is in the alarm condition.

- **DISPLAY OUTPUT:** The Display output is a pulse output connected to the Unit Diagnostic Display (UDD) and it pulses 24VAC when the unit is in an lockout alarm condition.
- **TEST DIP SWITCH:** A test dip switch is provided to reduce all time delays settings to 10 seconds during troubleshooting or verification of unit operation.



NOTE: Operation of unit in test mode can lead to accelerated wear and premature failure of components. The "TEST" switch must be set back to "NO" after troubleshooting/servicing.

- FREEZE SENSOR:** The default setting for the freeze limit trip is 26°F (sensor number 1); however this can be changed to 15°F by cutting the R30 resistor located on top of the DIP switch SW1. The default setting for the freeze limit trip is 26°F (sensor number 1); however this can be changed to 15°F by cutting the R24 resistor located on top of the DIP switch SW1. Since freeze sensor 2 is dedicated to monitor the evaporator coil it is recommended to leave the factory default setting on the board. The UPM controller will constantly monitor the refrigerant temperature with the sensor mounted close to the condensing water coil between the thermal expansion valve and water coil. If temperature drops below or remains at the freeze limit trip for 30 seconds, the controller will shut the compressor down and enter into a soft lockout condition. Both the status LED and the Alarm contact will be active. The LED will flash (three (3) times) the code associated with this alarm condition. If this alarm occurs 2 times (or 4 if Dip switch is set to 4) within an hour the UPM controller will enter into a hard lockout condition. Sensor number 2 will constantly monitor the refrigerant temperature with the sensor mounted close to the evaporator between the thermal expansion valve and evaporator coil as shown in Figure #5. If temperature drops below or remains at the freeze limit trip for 30 seconds, the controller will shut the compressor down and enter into a soft lockout condition. Both the status LED and the Alarm contact will be active. The LED will flash (six (6) times) the code associated with this alarm condition. If this alarm occurs 2 times (or 4 if Dip switch is set to 4) within an hour the controller will enter into a hard lockout condition.

NOTE: Freeze sensor will not guard against the loss of water. Flow switch is recommended to prevent unit from running if water flow is lost or reduced.

- INTELLIGENT RESET:** If a fault condition is initiated, the 5 minute delay on break time period is initiated and the unit will restart after these delays expire. During this period the fault LED will indicate the cause of the fault. If the fault condition still exists or occurs 2 or 4 times (depending on 2 or 4 setting for Lockout dip switch) before 60 minutes, the unit will go into a hard lockout and requires a manual lockout reset. A single condensate overflow fault will cause the unit to go into a hard lockout immediately, and will require a manual lockout reset.
- LOCKOUT RESET:** A hard lockout can be reset by turning the unit thermostat off and then back on when the “RESET” dip switch is set to “Y” or by shutting off unit power at the circuit breaker when the “RESET” dip switch is set to “R”.



The blower motor will remain active during a lockout condition.

ECM INTERFACE BOARD

Refer to Figure #97, item [12] for ECM interface board location. In addition to providing a connecting point for thermostat wiring, the interface board also translates thermostat inputs into control commands for the Electronic Commutated Motor (ECM) DC fan motor and provides thermostat signals to unit’s UPM board. The thermostat connections and their functions are as follows:

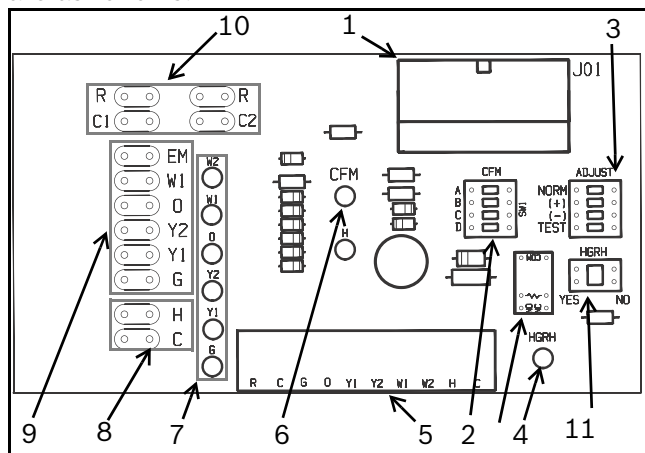

Figure # 102

- Motor harness plug
- Blower CFM adjustment
- Motor settings
- Dehumidification indication
- Thermostat contact inputs
- CFM count indicator
- Thermostat input status indication

- [8] Reheat digital outputs
- [9] Thermostat outputs
- [10] 24 VAC
- [11] Dehumidification method selector



CFM LED indication is an approximation. Utilize conventional Test and Balance equipment for accurate airflow measurement.

- CFM count indicator (Figure #102 item [6]) blinks to indicate approximate airflow in CFM and may flicker when the unit is off.
- Each blink of the LED represents approximately 100 CFM of air delivery so if the LED blinks 12 times, pauses, blinks 12 times, etc. the blower is delivering approximately 1200 CFM.

Thermostat Outputs	
Y1	First Stage Compressor Operation
Y2	Second Stage Compressor Operation
G	Fan
O	Reversing Valve (energized in cooling)
W1	Auxiliary Electric Heat (runs in conjunction with compressor)
EM/W2	Emergency Heat (electric heat only)
NC	Transformer 24 VAC Common (extra connection)
C1	Transformer 24 VAC Common (primary connection)
R	Transformer 24 VAC Hot
H	Dehumidification Mode

Airflow Selector

The airflow selector (Figure #102, items [2] & [3]) allows airflow adjustment to meet application requirements and to ease troubleshooting.



Only one dip switch can be enabled at a time. Refer to Figure #103 for each airflow setting.

- CFM Selector (Figure #102, Item [2]) must remain with only “A” being enabled.

- ADJUST Selector can be adjusted to NOM, (+), (-), or TEST. NOM, (+) and (-) can be adjusted as needed by application. TEST is used for troubleshooting to override unit airflow to 100%.

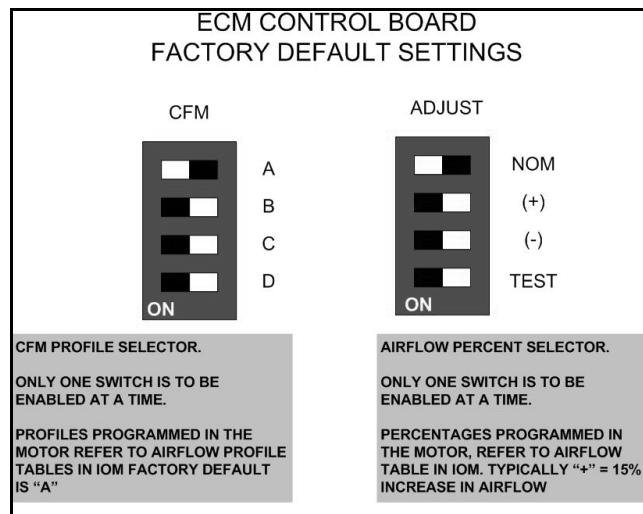

Figure # 103



Do not set the ADJ DIP switch to the (-) setting when electric heaters are installed. Doing so may cause the heaters to cycle on their thermal overload switches, potentially shortening the life of the switches.



Always disconnect power before changing DIP switch positions on the interface board and reset the unit afterward.

Dehumidification Method Selector

Dehumidification method selector (Figure #102, item [11]) is used to select between the following two methods:

1. Units equipped with optional Hot Gas Reheat, on dehumidification call (the “H” terminal on the thermostat is energized) the reheat outputs will energize the hot gas reheat valve in the circuit and the heat pump will start in dehumidification mode. Dehumidification selector (Figure #102, item [11]) should be selected to ‘YES’.
2. Units without optional Hot Gas Reheat, on dehumidification call, the heat pump fan will operate at a lower speed to increase dehumidification while cooling. Dehumidification selector ((Figure #104, item [11]) should be selected to ‘NO’.



In this mode, the heat pump will only dehumidify the space when it is running in cooling mode.

- To the left of the red and green status LED's is a row of 1/4" male quick connects. These are used to pass thermostat inputs on to the rest of the control circuit. Remember to always turn off unit power at the circuit breaker before attaching or disconnecting any wiring from these connections to avoid accidental short circuits that can damage unit control components.

Dehumidification indicator LED (Figure #104, item [4]) will energize when dehumidification call is present.

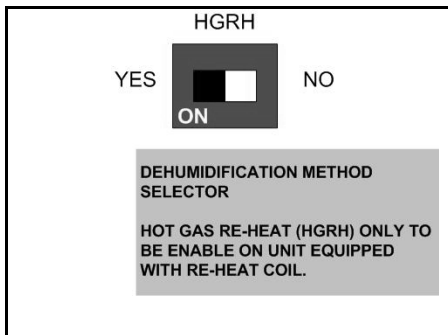

Figure # 104

Constant Torque Motors (ECM)

For installations where the efficiency of an electronically commutated brushless DC motor (ECM) motor is required, but the features of a constant airflow motor are not required, the LM series comes standard with the constant torque ECM motor option. These motors feature up to 90% thermal efficiency combined with a flatter fan curve than a PSC motor and simple operation. These motors are provided with 5 speed taps to allow for a wide range of air flow and external static options.

To change a speed tap follow the instructions below:

- Disconnect power to the heat pump.
- Remove the blower access panel.
- Remove the speed tap wire from the terminal it is currently connected to and connect it to the terminal desired.

Refer to the constant torque motor performance tables for heat pump blower performance with the constant torque motor option. (Pg#62)

OPTIONS

Number of factory installed options are available on SM Series of Heat Pumps. The following details the purpose, function and components of each option.

Hot Gas Reheat (HGRH)

Hot gas reheat is an active dehumidification option available on the SM series that cools and dehumidifies return air, and then reheats it back to approximately entering dry bulb temperature using waste compressor heat. In this way, a unit with Hot Gas Reheat can efficiently remove humidity from the return air without altering the sensible temperature of the space.



Hot Gas Reheat (HGRH) Option is not available on SM024 model or on models with Electric Heat installed.

The reheat option consists of a refrigerant to air heat exchanger (reheat coil) mounted down stream of the evaporator coil and a refrigerant diverting valve. When there is a signal for dehumidification AND the sensible space temperature is satisfied, the unit will operate in reheat mode. In reheat mode the heat pump will operate at full load cooling and will divert discharge gas from the compressor to the reheat coil, effectively cooling and dehumidifying the air and then reheating it back to a temperature close to the entering dry bulb temperature. If there is a call for sensible cooling while the unit is operating in the reheat mode, then the unit will revert to cooling until the sensible demand is satisfied.



NOTE: Heat pumps with hot Gas Reheat need to be connected to a humidistat along with a traditional thermostat or a combination thermostat/humidistat.

Electric Heat

Internally mounted supplemental electric heat is available on select models of the SM series. Electric heating elements can operate along with reverse cycle heating as auxiliary heat or in lieu of mechanical heating (refrigeration heating) as emergency backup heat.

Availability matrix, including available nominal kW capacities is shown below:



Internal mounted Electric Heat is only available on top blow vertical cabinets, end blow horizontal cabinet or on down blow counterflow cabinets. Electric Heat is not available on units with HGRH.



In cases where Electric Heat is not available in a desired configuration but is needed, contact your distributor for available Duct Mounted Electric Heat Package.



NOTE: Internal electric heat cannot be provided with hot gas reheat. Units with internal electric heat must have 2 field power supplies.

Heater Model	KW		Stgs	Btu/h		Product Series Compatibility				
	208V	230V		208V	230V	SM024	SM036	SM048	SM060	SM070
HK050-1201	3.6	4.8	1	12300	16300	x	x	x	x	x
HK100-1201	7.2	9.6	2	24600	32700	x #	x	x	x	x
HK150-1201	10.8	14.4	2	36900	49100		x #	x	x	x
HK200-1201	14.4	19.2	2	49200	63400			x #	x	x

x Available

Only available for units with ECM Constant Airflow Motor.

Heat Recovery Package (HRP)

The heat recovery package is a factory installed option on SM series of heat pumps. The HRP can be used to heat potable water during unit operation using waste heat from the compressor discharge gas. In some cases the HRP can provide most or all of the hot water requirements for a

typical home.

The HRP consists of three major components:

- double wall, vented refrigerant to water heat exchanger
- circulating pump
- control circuit

The heat exchanger is rated for use with potable water and is acceptable for use as a domestic water heating device in most building codes.

The pump circulates water between the domestic hot water tank and HRP heat exchanger in the Heat Pump. The control circuit ensures that the HRP only operates when there is available heat from the compressor and when the water is within a safe temperature range of below 140 deg F.

When the heat pump compressor operates, the HRP will monitor the temperature of the discharge gas from the compressor. Once discharge gas is hot enough to provide useful heat to the domestic water tank, the circulating pump will be enabled, drawing water from the tank, through the HRP heat exchanger and then depositing the heated water back into the tank. If the water temperature reaches 140 deg F, the circulating pump is disabled to prevent over heating of the domestic water. The HRP is provided with an on/off switch in case the end user desires that the HRP be inactivated (typically during the winter months when space heating is most important).



NOTE: If heat recovery unit is installed in an area where freezing may occur, the unit must be drained during winter months to prevent heat exchanger damage. Heat exchanger ruptures that occur due to freezing will void the heat recovery package warranty along with the heat pump warranty.

Constant Airflow Motor

The Constant Airflow Motor is an Electronic Commutated Motor (ECM) that provides a constant air flow over a wide range of external static pressures, while optimizing the power consumption of the motor.

This option allows the unit to have different air flow settings depending on the mode that the unit is operating; i.e heating, cooling, fan only, hot gas reheat, etc. Refer to the ECM Interface Board section (pg.35) for more information.

DPS Water Flow Proving

The DPS water flow proving switch is a factory installed option available for the SM series. The DPS prevents compressor operation if there is inadequate water flow through the water to refrigerant heat exchanger in the heat pump.

The DPS operates by monitoring the water side pressure drop across the water to refrigerant heat exchanger. When the pressure drop between the water in and water out lines reaches a pre-set value, compressor operation is enabled.

Pump Relay

The factory installed pump relay can be used to energize a supply pump or solenoid valve when there is a call for compressor operation. This relay can be used to switch either high or low voltage power.

Comfort Alert Module

The Comfort Alert diagnostics module (CADM) is a breakthrough innovation for troubleshooting heat pump system failures. (Figure #105)



Figure # 105

By monitoring and analyzing data from the compressor and the thermostat demand, the module can accurately detect the cause of electrical and system related failures without any sensors. A flashing LED indicator communicates the ALERT code and guides the service technician more quickly and accurately to the root cause of a problem.



This module does not provide safety protection! The Comfort Alert module is a monitoring device and cannot shut down the compressor directly.

When an abnormal system condition occurs, the Comfort Alert module displays the appropriate ALERT and/or TRIP LED.

The yellow ALERT LED will flash a number of times consecutively, pause and then repeat the process. To identify a Flash Code number, count the number of consecutive flashes.

Every time the module powers up, the last ALERT Flash Code that occurred prior to shut down is displayed for one minute.

SMART START ASSIST

SM series are available with the Smart Start Assist device as either a factory installed option or a field installed accessory.

This device reduces starting (in-rush) current for compressors by 45% to 65%. This reduction in starting current can eliminate or greatly reduce “light flickering” during compressor starts and can reduce the required size of back-up transformers. the adaptive technology of the device can also extend compressor life by providing smoother, lower currents starts and by protecting the compressor from transient over voltage and under voltage after ramp up.

The smart Start is designed for single phase scroll compressors and can also optimize algorithms for high pressure starts.

Smart Start Assist as showed in figure #106.

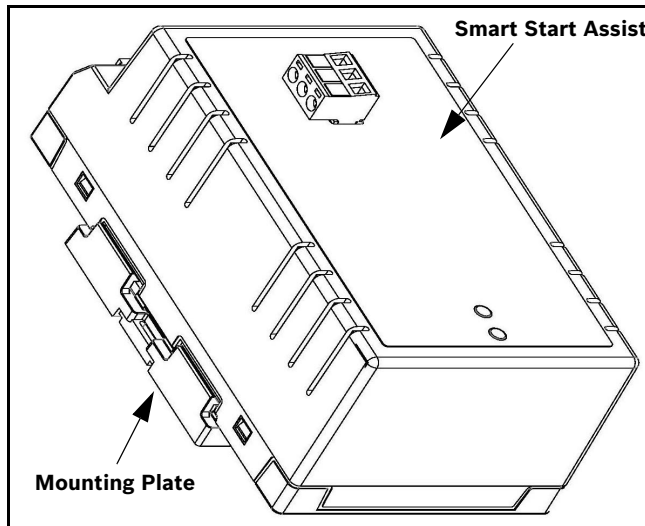

Figure # 106

SSA Specifications

Rated Operational Voltage:	208/230VACrms +/- 15% 50-60 Hz
Environmental Operating Range:	-4° to 149°F (-20° to 65°C); < 95% @ 40 C relative humidity, non-condensing
Degree of Protection:	IP20
Overvoltage:	Category II
Operational Rated Current:	32 Amps
Max Starting Current:	80A ACrms
Min Full Load Current:	80A ACrms
Min time between starts:	6 minutes
Min time between stop to start:	3 minutes

Mode of Operation

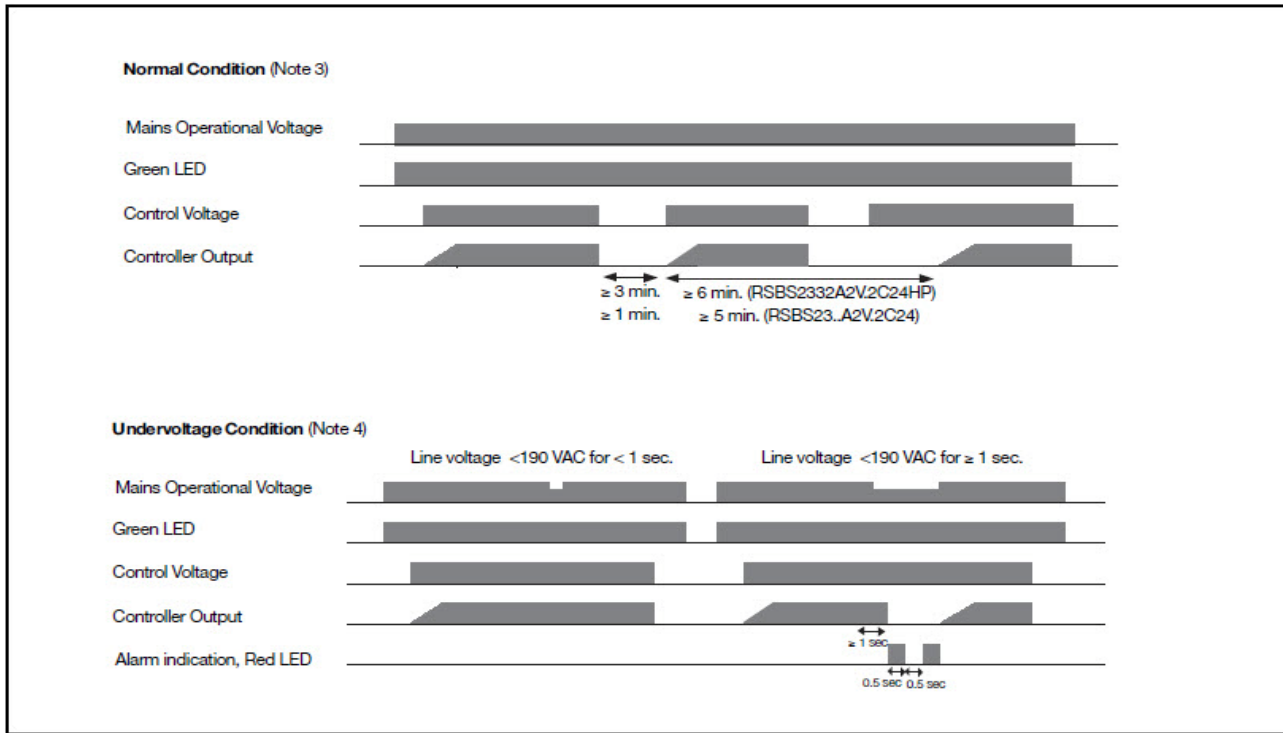

Figure # 107

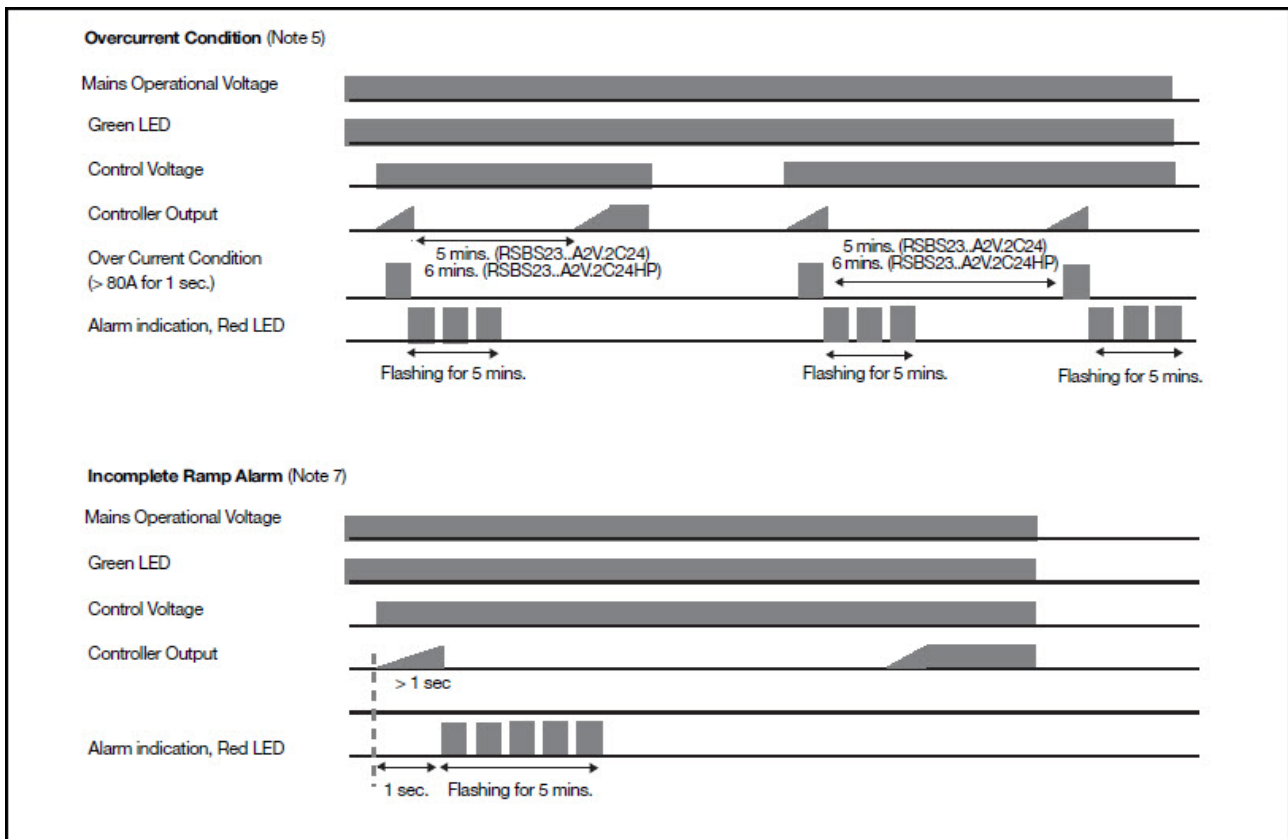

Figure # 108

Mode of operation Notes

1. The Smart Start Assist has 2 indication LEDs on board. The green LED indicates the status of the on-board power supply while the red LED indicates an alarm condition or the recovery time between starts.*
2. Once the main voltage is present, the green LED will be fully ON. In case the main voltage is less than the stated pickup voltage alarm value, the green LED will be flashing. In case main voltage is higher than the stated pick-up voltage and green LED is flashing, then this may indicate that the on-board power supply is faulty. (Power Supply Alarm)
3. Upon closing K1, the Smart Start Assist will start ramping, duration of which is < 1 second, provided that the minimum time from stop to start is respected. When opening K1, the Smart Start Assist will stop without any ramp down.
4. In the case of an under voltage, the Smart Start Assist will shut down and the red LED flashes 2 times as long as the under voltage is present. Once the main voltage is restored the red LED will continue flashing for 5 minutes. Following these 5 minutes (6 minutes for HP versions), the Smart Start Assist will start ramping function in the case K1 is closed. The device can be reset at any time by removing power on L1-N connection. When the power is reapplied, the soft starter will start ramping up as soon as K1 is closed, provided that the minimum time from stop to start are respected.
5. If an over current (>80A for 1 sec.) is sensed, the Smart start Assist will shut down and the red LED will flash 3 times indicating an over current situation. This continues for 5 minutes. In the case that the over current is still present at the second attempt, user intervention is required to reset the controller by cycling power for the device to operate again as this implies that there are problems in the system.
6. A detection circuitry provides protection in case of a faulty starting capacitor EMR. In such situation, the red LED will flash 4 times for 5 minutes. Smart Start Assist will check the status of the starting capacitor EMR before attempting a ramping function (in the case K1 is closed). If at the second attempt, the starting capacitor EMR is found to be faulty, user intervention is required to reset the controller by cycling power for the device.
7. In the case of incomplete ramping of the Smart Start Assist, the red LED will flash 5 times. The flashing will be indicated by the red LED for 5 minutes. If after the second attempt, there is another incomplete ramp alarm, user intervention is required to reset the controller.
8. During the recovery from under-voltage, over-current and incomplete ramp alarms, the red LED will flash twice

the normal flashing frequency using the same number of flashes. The figure #108 shows the flashing in case of a recovery from an under-voltage alarm.

9. During the recovery time between starts, the Smart Start Assist will be continuously ON until the necessary recovery time elapses.*

10. If Power supply on Smart Start Assist is removed before the recovery period has elapsed, when supply is restored, the delay will continue until the remaining recovery time from the last start/stop (before supply removal) is over. Following this, another start may be attempted. If supply is removed during alarm recovery (red LED flashing), when supply is restored, the alarm will be reset and the Smart Start Assist will only wait for the respective delays between starts and/or stop to start to elapse before attempting another start (assuming K1 is closed).

*Applicable to HP versions only

HEAT RECOVERY PACKAGE

Water Tank Preparation

1. Turn off electrical or fuel supply to the water heater.
2. Attach garden hose to water tank drain connection and run other end of hose out doors or to an open drain.
3. Close cold water inlet valve to water heater tank.
4. Drain tank by opening drain valve on the bottom of the tank, then open pressure relief valve or hot water faucet.
5. Once drained the tank should be flushed with cold water until the water leaving the drain hose is clear and free of sediment.
6. Close all valves and remove the drain hose.
7. Install HR water piping.



Concentric water fitting (p/n 8733907119) is recommended.

HR Water Piping

All hot water piping MUST be a minimum of 3/8" O.D. copper tube to a maximum distance of 15 feet. For distances beyond fifteen feet but not exceeding 60 feet use 1/2" copper tube. Separately insulate all exposed surface of both connecting water lines with 3/8" wall closed cell insulation. Install isolation valves on supply and return to the heat recovery. (Figure #109)

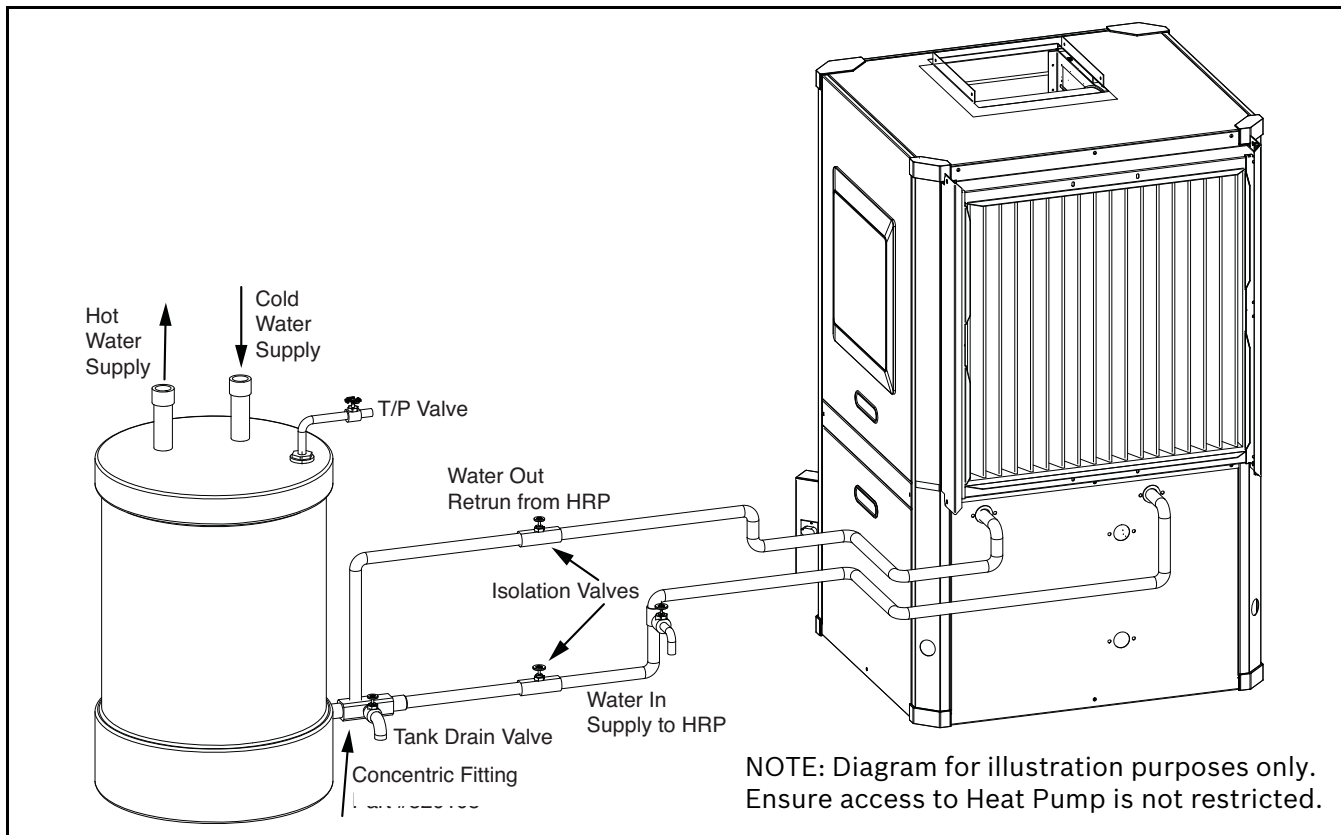

Figure # 109

Water Tank Refill

1. Open the cold water supply to the tank.
2. Open a hot water faucet to vent air from the system until water flows from the faucet, then close.
3. Depress the hot water tank pressure relief valve handle to ensure there is no air remaining in the tank.
4. Carefully inspect all plumbing for water leaks. Correct as required.
5. Purge all air from HR through an external purge valve. Allow all air to bleed out until water appears at the valve. Locate the external purge value at the highest point in installation.
6. Before restoring the power or fuel supply to the water heater, adjust the temperature setting on the tank thermostat(s) to ensure maximum utilization of the heat available from the refrigeration system and conserve the most energy. On tanks with both upper and lower elements and thermostats, the lower element should be turned down to 100° F, while the upper element should be adjusted to 120° F. Depending upon the specific needs of the customer, you may need to adjust the upper element differently. On tanks with a single thermostat lower the thermostat setting to 120° F or the "LOW" position. After thermostat adjustments are completed, replace access cover and restore electrical or fuel supply to water heater.



NOTE: All piping from HRP to domestic water tank must be copper or any metal of stronger alloy.

INITIAL START-UP



NOTE: Make sure all valves in heat recovery water piping system are open. NEVER OPERATE HR PUMP DRY.

1. Turn on the heat pump. The HR pump should not run if the compressor is not running.
2. Turn HR switch to the "ON" position. The pump will operate if entering water temperature to HR is below 120° F.
3. The temperature difference between the water entering and leaving the heat recovery should be 5° to 15° F.
4. Allow the unit to operate for 20 to 30 minutes to ensure it is functioning properly. The pump should shut off when the water temperature entering the heat recovery reaches 120°F.

SEQUENCE OF OPERATION

Cooling Mode

Energizing the "O" terminal energizes the unit reversing valve thus placing the unit into cooling mode. The fan motor starts when the "G" terminal is energized.



The fan motor will take 30 seconds to ramp up to operating speed and will run at fan only rated air flow as long as there is no call for compressor or heater operation.

When the thermostat calls for first stage cooling (Y1) the loop pump or solenoid valve if present is energized and the first stage of compressor capacity starts. The fan ramps up to first stage cooling air flow in 30 seconds.



Some options will have a built in delay, and hence, compressor operation is not immediate. See 'Options' sections for more detail.

When the thermostat calls for second stage cooling (Y2) the second stage (or full compressor capacity) is initiated. The fan ramps up to full cooling air flow.

Once the thermostat is satisfied, the compressor shuts down and the fan ramps down to either fan only mode or off over a span of 30 seconds.



Note that a fault condition initiating a lockout will de-energize the compressor irrespective of which stage is engaged.

Heating Mode

The first two stages of heating (Y1 & Y2) operate in the same manner as cooling, but with the reversing valve de-energized. On a call for auxiliary heat (W1), the fan ramps up to auxiliary heat air flow immediately and the electric heater package is energized along with the compressor.

As the thermostat is satisfied, the heaters will shut off as soon as W1 is de-energized, and the compressors will remain on until the thermostat stages are satisfied.



If the unit compressor locks out for any reason at this time, the electric heaters will continue to function normally.

Once the thermostat is satisfied, the compressor shuts down and the fan ramps down either fan only mode or off over a span of 30 seconds. If thermostat has two different output points one for Auxiliary heat and a different one for Emergency heat the two outputs must be terminated on W1 units equipped with one stage of Electric heat. (Figure #115)



When using a 2-cool, 3-heat thermostat both the W1 & W2 on the Heat Pump and W2 & EM on the thermostat must be connected together via a jumper. (See Figure#115)

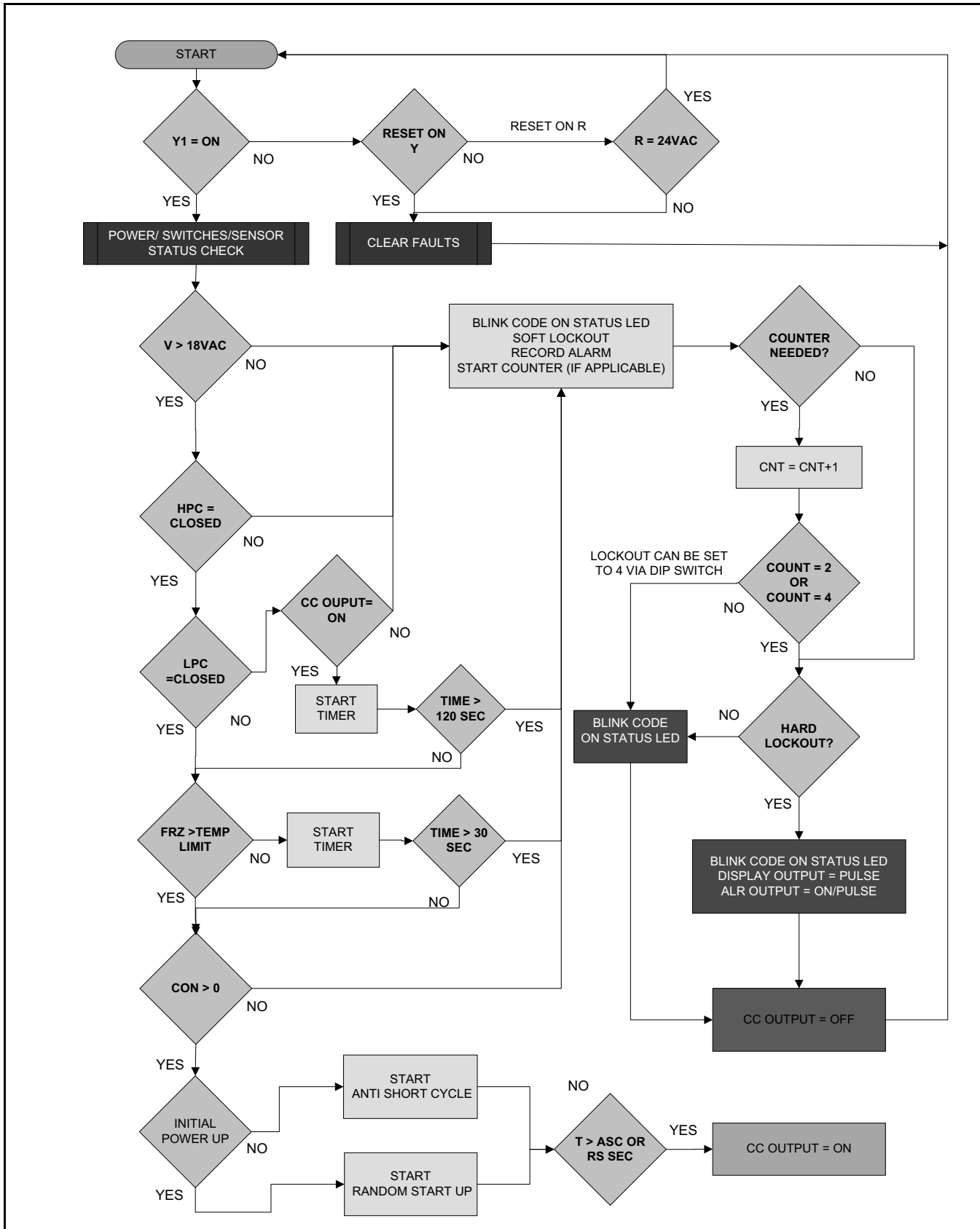

Figure # 110

APPLICATION CONSIDERATIONS

Well Water Systems

Copper is adequate for ground water that is not high in mineral content. Should your well driller express concern regarding the quality of the well water available or should any known hazards exist in your area, we recommend proper testing to assure the well water quality is suitable for use with water source equipment. In conditions anticipating moderate scale formation or in brackish water a cupro-nickel heat exchanger is recommended. In well water applications water

pressure must always be maintained in the heat exchanger. This can be accomplished with either control valve or a bladder type expansion tank. When using a single water well to supply both domestic water and the heat pump care must be taken to insure that the well can provide sufficient flow for both. In well water applications a slow closing solenoid valve must be used to prevent water hammer. Solenoid valves should be connected across Y1 and C1 on the interface board for all. Make sure that the VA draw of the valve does not exceed the contact rating of the thermostat. (Figure #111)

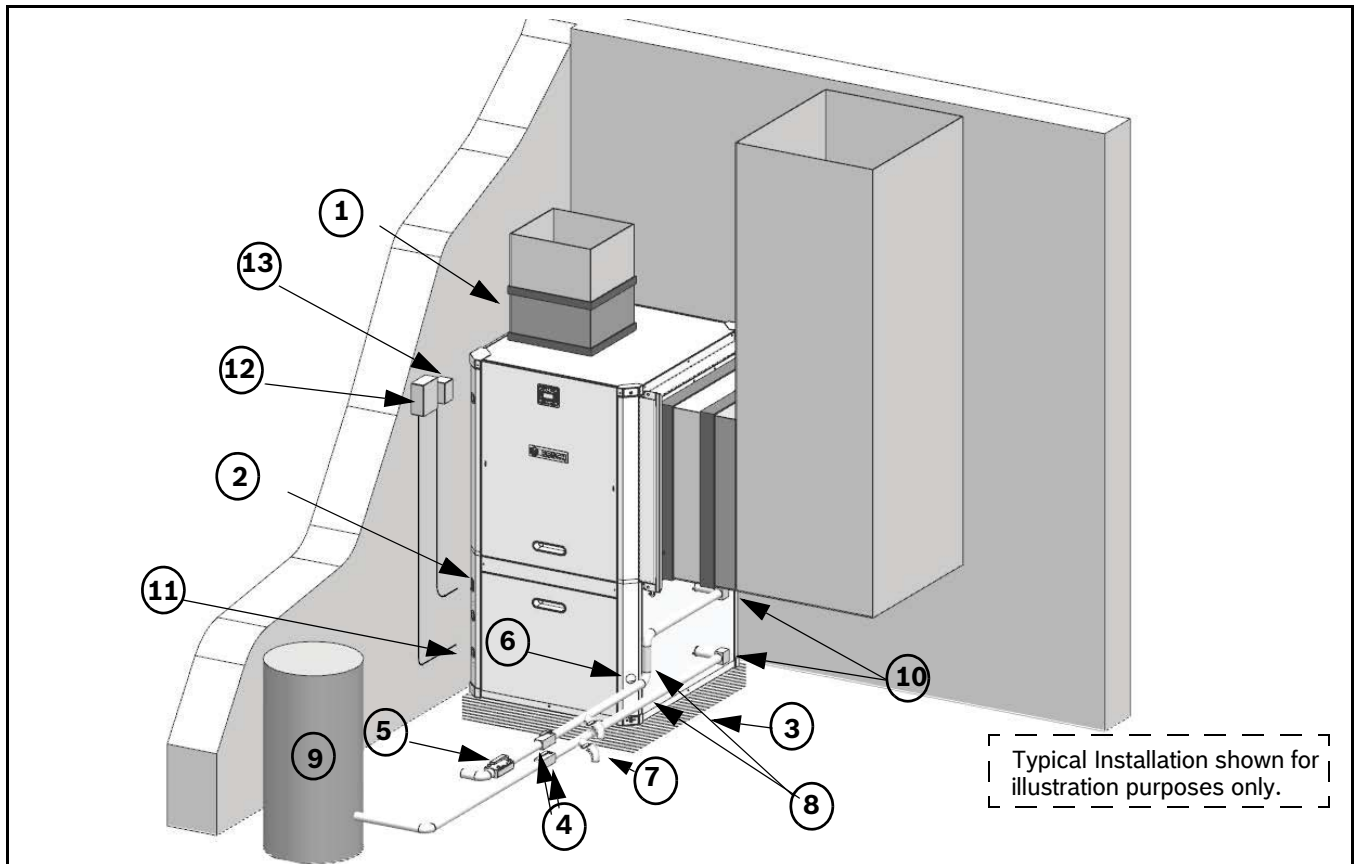

Figure # 111 Example System Set-up

- [1] Flex Duct Connection
- [2] Low Voltage Control Connection
- [3] Vibration Pad
- [4] Ball Valves
- [5] Solenoid Valve Slow Closing
- [6] Condensate Drain Connection
- [7] Drain Valves
- [8] Hose Kits (optional)
- [9] Pressure Tank (optional)
- [10] P/T Ports (optional)
- [11] Line Voltage Connection
- [12] Electric Heater Line Voltage Disconnect
- [13] Unit Line Voltage Disconnect

Cooling Tower/Boiler Systems

The cooling tower and boiler water loop temperature is usually maintained between 50° F to 100° F to assure adequate cooling and heating performance.

In the cooling mode, heat is rejected from the unit into the water loop. A cooling tower provides evaporative cooling to the loop water thus maintaining a constant supply temperature to the unit. When utilizing open cooling towers, chemical water treatment is mandatory to ensure the water is free from corrosive elements. A secondary heat exchanger (plate frame) between the unit and the

open cooling tower may also be used. It is imperative that all air be eliminated from the closed loop side of the heat exchanger to insure against fouling. In the heating mode, heat is absorbed from the water loop. A boiler can be utilized to maintain the loop at the desired temperature.



NOTE: Water piping exposed to extreme low ambient temperatures is subject to freezing.



Teflon tape sealer should be used when connecting to the unit to insure against leaks and possible heat exchanger fouling.

Consult the specification sheets for piping sizes.

Do not overtighten the connections. Flexible hoses should be used between the unit and the rigid system to avoid possible vibration.

Ball valves should be installed in the supply and return lines for unit isolation and unit water flow balancing. Pressure/temperature ports are recommended in both supply and return lines for system flow balancing. Water flow can be accurately set by measuring the water-to-refrigerant heat exchangers water side pressure drop. See specification sheets for water flow vs. pressure drop information.

No unit should be connected to the supply or return piping until the water system has been completely cleaned and flushed to remove any dirt, piping chips or other foreign material. Supply and return hoses should be connected together during this process to ensure the entire system is properly flushed. After the cleaning and flushing has taken place the unit may be connected to the water loop and should have all valves wide open. (Figure #112)

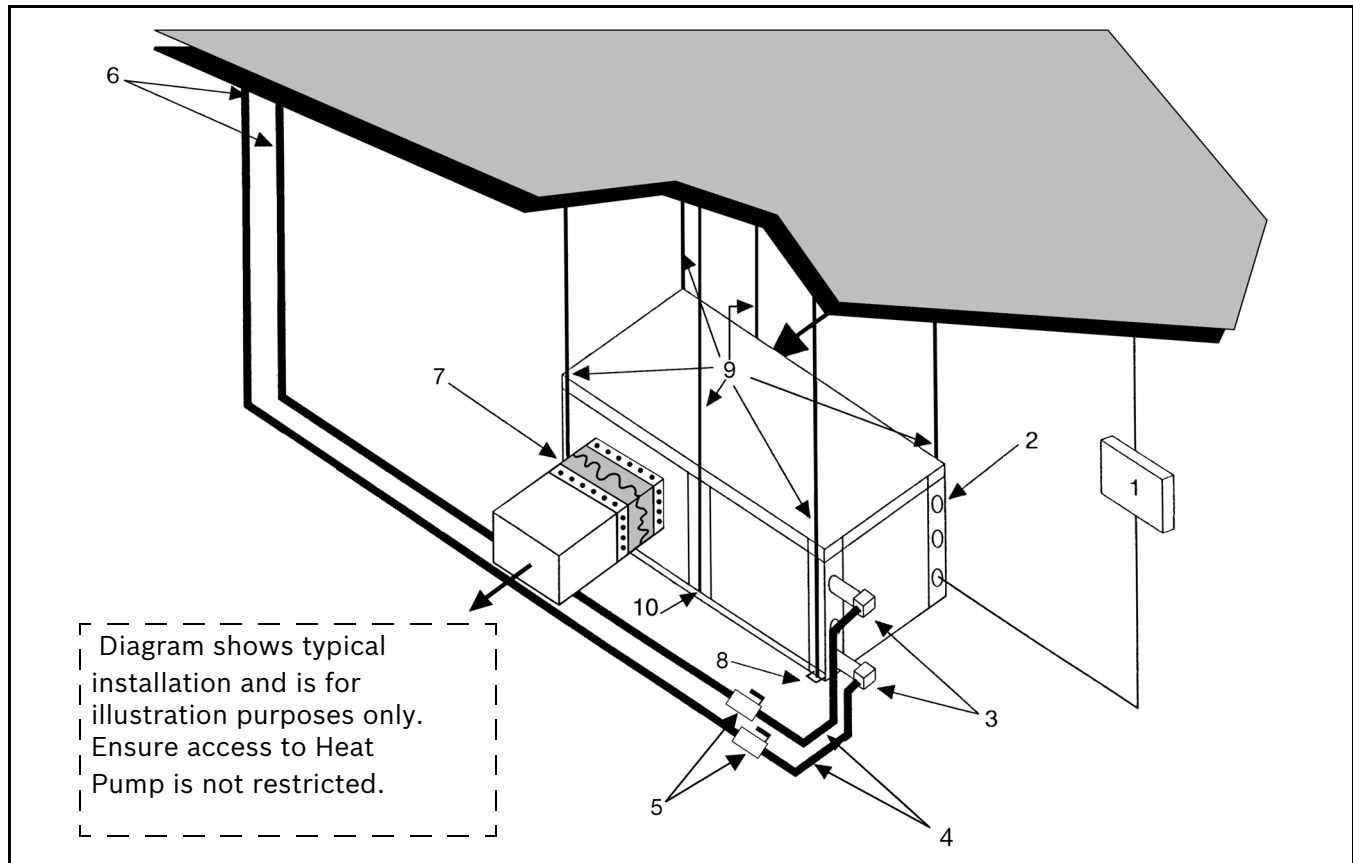

Figure # 112

- | | |
|--|-------------------------------|
| [1] Line voltage disconnect (unit) | [8] Hanging bracket assembly |
| [2] Low voltage control connection | [9] Threaded rod |
| [3] P/T ports (optional) | [10] Hanging bracket assembly |
| [4] Hose kits (optional) | |
| [5] Ball valves | |
| [6] Supply and return line of central system | |
| [7] Flex duct connection | |

Geothermal Systems

Closed loop and pond applications require specialized design knowledge. No attempt at these installations should be made unless the dealer has received specialized training. Utilizing the Ground Loop Pumping Package (GLP), makes the

installation easy. Anti-freeze solutions are utilized when low evaporating conditions are expected to occur. Refer to the GLP installation manuals for more specific instructions. (Figure #113)

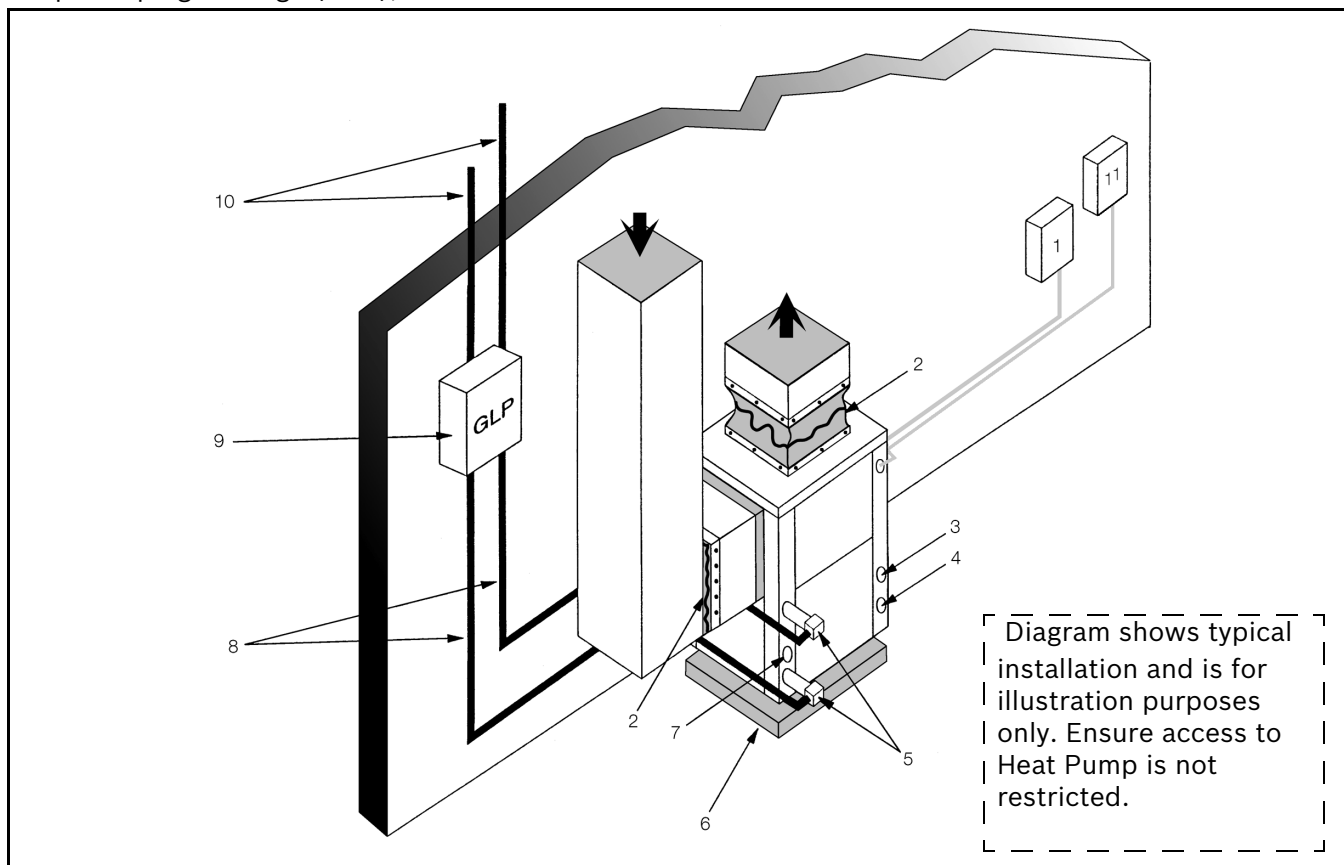

Figure # 113

- [1] Line voltage disconnect (unit)
- [2] Flex duct Connection
- [3] Low voltage control connection
- [4] Line voltage connection (unit)
- [5] P/T ports
- [6] Vibration pad
- [7] Condensate drain connection
- [8] Ground loop connection kit
- [9] Ground loop pumping package
- [10] Polyethylene with insulation
- [11] Line voltage disconnect (electric heater)

SYSTEM CHECKOUT

After completing the installation, and before energizing the unit, the following system checks should be made:

1. Verify that the supply voltage to the heat pump is in accordance with the nameplate ratings.
2. Make sure that all electrical connections are tight and secure.
3. Check the electrical fusing and wiring for the correct size.



DANGER: Ensure cabinet and Electrical Box are properly grounded.

4. Verify that the low voltage wiring between the thermostat and the unit is correct.
5. Verify that the water piping is complete and correct.
6. Check that the water flow is correct, and adjust if necessary.
7. Check the blower for free rotation, and that it is secured to the shaft.
8. Verify that vibration isolation has been provided.
9. Unit is serviceable. Be certain that all access panels are secured in place.

Considerations:

- Always check incoming line voltage power supply and secondary control voltage for adequacy. Transformer primaries are dual tapped for 208 and 230 volts. Connect the appropriate tap to ensure a minimum of 18 volts secondary control voltage. 24 volts is ideal for best operation.
- Long length thermostat and control wiring leads may create voltage drop. Increase wire gauge or up-size transformers may be required to insure minimum secondary voltage supply.
- FHP recommends the following guidelines for wiring between a thermostat and the unit: 18 GA up to 60 foot, 16 GA up to 100 ft and 14 GA up to 140 ft.
- Do not apply additional controlled devices to the control circuit power supply without consulting the factory. Doing so may void equipment warranties.
- Check with all code authorities on requirements involving condensate disposal/over flow protection criteria.

UNIT START-UP

1. Set the thermostat to the highest setting.
2. Set the thermostat system switch to “COOL”, and the fan switch to the “AUTO” position. The reversing valve solenoid should energize. The compressor and fan should not run.
3. Reduce the thermostat setting approximately 5 degrees below the room temperature.
4. Verify the heat pump is operating in the cooling mode.
5. Turn the thermostat system switch to the “OFF” position. The unit should stop running and the reversing valve should de energize.
6. Leave the unit off for approximately (5) minutes to allow for system equalization.
7. Turn the thermostat to the lowest setting.
8. Set the thermostat switch to “HEAT”.
9. Increase the thermostat setting approximately 5 degrees above the room temperature.
10. Verify the heat pump is operating in the heating mode.
11. Set the thermostat to maintain the desired space temperature.
12. Check for vibrations, leaks, etc.

MAINTENANCE

1. Filter changes or cleaning are required at regular intervals. The time period between filter changes will depend upon type of environment the equipment is used in. In a single family home, that is not under construction, changing or cleaning the filter every 60 days is sufficient. In other applications such as motels, where daily vacuuming produces a large amount of lint, filter changes may need to be as frequent as biweekly.



NOTE: Equipment should never be used during construction due to likelihood of wall board dust accumulation in the air coil of the equipment which permanently affects the performance and may shorten the life of the equipment.

2. An annual “checkup” is recommended by a licensed refrigeration mechanic. Recording the performance measurements of volts, amps, and water temperature differences (both heating and cooling) is recommended. This data should be compared to the information on the unit’s data plate and the data taken at the original startup of the equipment.
3. Lubrication of the blower motor is not required, however may be performed on some motors to extend motor life. Use **SAE-20** non-detergent electric motor oil.
4. The condensate drain should be checked annually by cleaning and flushing to insure proper drainage.
5. Periodic lockouts almost always are caused by air or water flow problems. The lockout (shutdown) of the unit is a normal protective measure in the design of the equipment. If continual lockouts occur call a mechanic immediately and have them check for: water flow problems, water temperature problems, air flow problems or air temperature problems. Use of the pressure and temperature charts for the unit may be required to properly determine the cause.

UNIT CHECK-OUT SHEET

Customer Data

Customer Name _____ Date _____
 Address _____

 Phone _____ Unit Number _____

Unit Nameplate Data

Unit Make _____
 Model Number _____ Serial Number _____
 Refrigerant Charge (oz) _____
 Compressor: RLA _____ LRA _____
 Blower Motor: FLA (or NPA) _____ HP _____
 Maximum Fuse Size (Amps) _____
 Maximum Circuit Ampacity _____

Operating Conditions

	Cooling Mode	Heating Mode
Entering / Leaving Air Temp	_____ / _____	_____ / _____
Entering Air Measured at:	_____	_____
Leaving Air Measured at:	_____	_____
Entering / Leaving Fluid Temp	_____ / _____	_____ / _____
Fluid Flow (gpm)	_____	_____
Compressor Volts / Amps	_____ / _____	_____ / _____
Blower Motor Volts / Amps	_____ / _____	_____ / _____
Source Fluid Type	_____	_____
Fluid Flow (gpm)*	_____	_____
Fluid Side Pressure Drop*	_____	_____
Suction / Discharge Pressure (psig)*	_____ / _____	_____ / _____
Suction / Discharge Temp*	_____ / _____	_____ / _____
Suction Superheat*	_____	_____
Entering TXV / Cap Tube Temp*	_____	_____
Liquid Subcooling*	_____	_____

* Required for Troubleshooting ONLY

Auxiliary Heat

Unit Make _____
 Model Number: _____ Serial Number _____
 Max Fuse Size (Amps) _____
 Volts / Amps _____
 Entering Air Temperature _____
 Leaving Air Temperature _____

Bosch Group
 601 NW 65th Court
 Fort Lauderdale, FL 33309
 Phone: (954) 776-5471
 Fax: (800) 776-5529



MAIL TO: Bosch.Fhp.TechSupport@us.bosch.com
 or scan the QR code and attach picture of this form with
 the information requested.

TROUBLESHOOTING

SM Series Water Source Heat Pump is equipped with an externally mounted LCD screen that displays unit errors. (Figure #114)

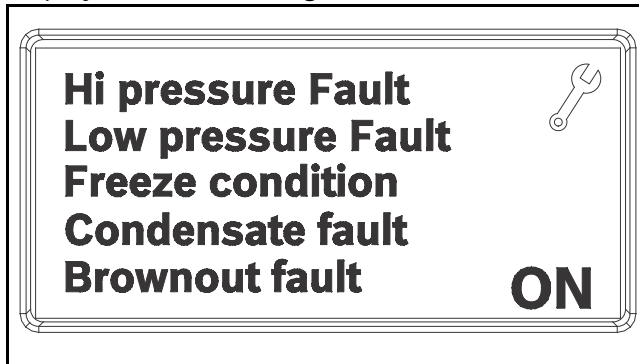

Figure # 114



Troubleshooting Information Solution column may reflect a possible fault that may be one of, or a combination of causes and solutions. Check each cause and adopt “process of elimination” and or verification of each before making any conclusion.

UPM Board LED Indications

Indication Color	Blinks	Description
GREEN	Solid	18-30 VAC Power is present
RED	1	High pressure lockout
RED	2	Low pressure lockout
RED	3	Freeze sensor lockout
RED	4	Condensate overflow
RED	5	Brownout
RED	6	Evaporator Freeze condition

Unit Troubleshooting

Problem	Possible Cause	Checks and Correction
ENTIRE UNIT DOES NOT RUN	Power Supply Off	Apply power, close disconnect
	Blown Fuse	Replace fuse or reset circuit breaker. Check for correct fuses
	Voltage Supply Low	If voltage is below minimum voltage specified on unit data plate, contact local power company.
	Thermostat	Set the fan to “ON”, the fan should run. Set thermostat to “COOL” and lowest temperature setting, the unit should run in the cooling mode (reversing valve energized). Set unit to “HEAT” and the highest temperature setting, the unit should run in the heating mode. If neither the blower or compressor run in all three cases, the thermostat could be miswired or faulty. To ensure miswired or faulty thermostat verify 24 volts is available on the condensing section low voltage terminal strip between “R” and “C”, “Y” and “C”, and “O” and “C”. If the blower does not operate, verify 24 volts between terminals “G” and “C” in the air handler. Replace the thermostat if defective.
BLOWER OPERATES BUT COMPRESSOR DOES NOT	Thermostat	Check setting, calibration, and wiring
	Wiring	Check for loose or broken wires at compressor, capacitor, or contactor.
	Safety Controls	Check UPM board red default L.E.D. for Blink Code
	Compressor overload open	If the compressor is cool and the overload will not reset, replace compressor.
	Compressor motor grounded	Internal winding grounded to the compressor shell. Replace compressor. If compressor burnout, install suction filter dryer.
	Compressor windings Open	After compressor has cooled, check continuity of the compressor windings. If the windings are open, replace the compressor

Unit Troubleshooting		
Problem	Possible Cause	Checks and Correction
UNIT OFF ON HIGH PRESSURE CONTROL	Discharge pressure too high	In "COOLING" mode: Lack of or inadequate water flow. Entering water temperature is too warm. Scaled or plugged condenser. In "HEATING" mode: Lack of or inadequate air flow. Blower inoperative, clogged filter or restrictions in duct work
	Refrigerant charge	The unit is overcharged with refrigerant. Reclaim refrigerant, evacuate and recharge with factor recommended charge.
	High pressure	Check for defective or improperly calibrated high pressure switch.
UNIT OFF ON LOW PRESSURE CONTROL	Suction pressure too low	In "COOLING" mode: Lack of or inadequate air flow. Entering air temperature is too cold. Blower inoperative, clogged filter or restrictions in duct work. In "HEATING" mode: Lack of or inadequate water flow. Entering water temperature is too cold. Scaled or plugged condenser.
	Refrigerant charge	The unit is low on refrigerant. Check for refrigerant leak, repair, evacuate and recharge with factory recommended charge.
	Low pressure switch	Check for defective or improperly calibrated low pressure switch.
UNIT SHORT CYCLES	Unit oversized	Recalculate heating and or cooling loads.
	Thermostat	Thermostat installed near a supply air grill; relocate thermostat. Readjust heat anticipator.
	Wiring and controls	Check for defective or improperly calibrated low pressure switch.
INSUFFICIENT COOLING OR HEATING	Unit undersized	Recalculate heating and or cooling loads. If excessive, possibly adding insulation and shading will rectify the problem
	Loss of conditioned air by leakage	Check for leaks in duct work or introduction of ambient air through doors or windows
	Airflow	Lack of adequate air flow or improper distribution of air. Replace dirty filter
	Refrigerant charge	Low on refrigerant charge causing inefficient operation
	Compressor	Check for defective compressor. If discharge is too low and suction pressure is too high, compressor is not pumping properly. Replace compressor.
	Reversing Valve	Defective reversing valve creating bypass of refrigerant from discharge of suction side of compressor. Replace reversing valve
	Operating pressures	Compare unit operation pressures to the pressure/temperature chart for the unit.
	TXV	Check TXV for possible restriction or defect. Replace if necessary.
	Moisture, noncondensables	The refrigerant system may be contaminated with moisture or noncondensables. Reclaim refrigerant, replace filter dryer, evacuate the refrigerant system, and recharge with factory recommended charge.

Compressor Ohms		
Model	Start Winding	Run Winding
SM024	1.64	1.3
SM036	1.52	0.88
SM048	1.86	0.52
SM060	1.63	0.39
SM070	1.85	0.34
Tolerance +/- 7%. All resistance values must be measured with compressor at room temperature.		

Comfort Alert Module -Flash Codes		
Status LED	Status LED Description	Status LED Troubleshooting Information Solution
YELLOW "ALERT" FLASH CODE 3	Short Cycling Compressor is running only briefly	<ol style="list-style-type: none"> 1. Thermostat demand signal is intermittent 2. Time delay relay or control board defective 3. If high pressure switch present go to Flash Code 2 information 4. If low pressure switch present go to Flash Code 1 information
YELLOW "ALERT" FLASH CODE 4	Locked Rotor	<ol style="list-style-type: none"> 1. Run capacitor has failed (may not be bad, verify) 2. Low line voltage (contact utility if voltage at disconnect is low) <ul style="list-style-type: none"> • Check wiring connections 3. Excessive liquid refrigerant in compressor 4. Compressor bearings are seized <ul style="list-style-type: none"> • Measure compressor oil level
YELLOW "ALERT" FLASH CODE 5	Open Circuit	<ol style="list-style-type: none"> 1. Outdoor unit power disconnect is open 2. Compressor circuit breaker or fuse(s) is open 3. Compressor contactor has failed open <ul style="list-style-type: none"> • Check compressor contactor wiring and connectors • Check for compressor contactor failure (burned, pitted or open) • Check wiring and connectors between supply and compressor • Check for low pilot voltage at compressor contactor coil 4. High pressure switch is open and requires manual reset 5. Open circuit in compressor supply wiring or connections 6. Unusually long compressor protector reset time due to extreme ambient temperature 7. Compressor windings are damaged <ul style="list-style-type: none"> • Check compressor motor winding resistance

Comfort Alert Module -Flash Codes

Status LED	Status LED Description	Status LED Troubleshooting Information Solution
YELLOW "ALERT" FLASH CODE 6	Open Start Circuit Current only in run circuit	<ol style="list-style-type: none"> Run capacitor has failed (may not be bad, verify) Open circuit in compressor start wiring or connections <ul style="list-style-type: none"> Check wiring and connectors between supply and the compressor "S" terminal Compressor start winding is damaged <ul style="list-style-type: none"> Check compressor motor winding resistance
YELLOW "ALERT" FLASH CODE 7	Open Run Circuit Current only in start circuit	<ol style="list-style-type: none"> Open circuit in compressor run wiring or connections <ul style="list-style-type: none"> Check wiring and connectors between supply and the compressor "R" terminal Compressor run winding is damaged <ul style="list-style-type: none"> Check compressor motor winding resistance
YELLOW "ALERT" FLASH CODE 8	Welded Contactor Compressor always runs	<ol style="list-style-type: none"> Compressor contactor has failed closed Thermostat demand signal not connected to module
YELLOW "ALERT" FLASH CODE 9	Low Voltage Control circuit < 17VAC	<ol style="list-style-type: none"> Control circuit transformer is overloaded Low line voltage (contact utility if voltage at disconnect is low) <ul style="list-style-type: none"> Check wiring connections Flash Code number corresponds to a number of LED flashes, followed by a pause and then repeated. TRIP and ALERT LEDs flashing at same time means control circuit voltage is too low for operation

HRP Troubleshooting

Problem	Possible Cause	Checks and Corrections
NO FLOW LOW FLOW	No Power	Check power supply
	On/Off Switch Position	Set switch to "ON" position
	Compressor Contactor	Engage heat pump contactor
	Broken or loose wires	Repair or tighten wires
	Air Lock	Purge air from piping system
	Stuck pump shaft/impeller	Remove pump cartridge and clean
	Defective pump	Replace pump
	Kinked or under sized water piping	Repair kink and check for proper line size
HIGH WATER TEMPERATURE	Water temp limit closed	Stuck limit switch Sensor not attached securely to line
LOW HEAT OUTPUT	Scaled or fouled heat exchanger	Clean heat exchanger

SMART START ASSIST LED STATUS INDICATION

Red Led	Relay Contact*	Condition	Action
FULLY ON +	11/12	Min. recovery time between starts and /or recovery time between stop to start	Auto reset when minimum recovery time elapses
2 FLASHES	11/14	Undervoltage ($U_e < 190VAC$)	Auto reset with 5 mins recovery **
3 FLASHES	11/14	Overcurrent (>80A for >1 sec.)	Auto reset with 5 mins recovery
4 FLASHES	11/14	relay protection	Auto reset with 5 mins recovery***
5 FLASHES	11/14	incomplete ramp	Auto reset with 5 mins recovery
N/A	11/12	Supply phase loss	Physical check
N/A	11/12	Idle state	
N/A	11/12	Ramping state	
N/A	11/12	Bypass mode	
Green Led	Relay Contact*	Condition	Action
FLASHING	11/12	Power supply alarm	Replace Smart Start device
FULLY ON	11/12	Idle State	RSBS waiting for control signal to start

+ APPLICABLE TO RSBS2332A2V.2C24HP. FOR MODELS, NO INDICATION ON THE RED LED IS PROVIDED
 *APPLIES ONLY TO RSB23XXA2V22C24..MODELS
 **MONITORED DURING IDLE AND BYPASS
 ***REFER TO NOTE 6 IN MODE OF OPERATION SECTION
 ****REFER TO VOLTAGE DIPS AND INTERRUPTIONS SECTION FOR MODE OF OPERATION

Smart Start Assist Flashing sequence

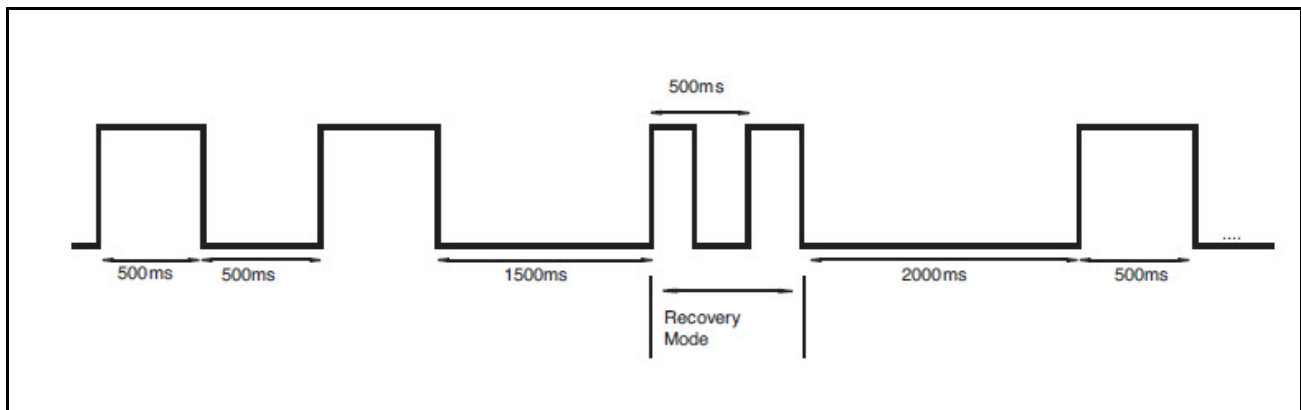

NOTE: During recovery from an alarm condition, the red LED will flash at twice the normal flashing frequency between successive flashing cycles as shown above to indicate that the Smart start Assist is in recovery mode which recovery lasts for 5 minutes.

ELECTRONIC THERMOSTAT

Installation

Position the thermostat subbase against the wall so that it is level and the thermostat wires protrude through the middle of the subbase. Mark the position of the subbase mounting holes and drill holes with a 3/16-inch bit. Install supplied anchors and secure base to the wall. Thermostat wire must be 8-conductor, 18-AWG wire. Strip the wires back 1/4-inch (longer strip lengths may cause shorts) and insert the thermostat wires into the connector as shown. Tighten the screws to ensure secure connections. The thermostat has the same type connectors, requiring the same wiring. See instructions in the thermostat for detailed installation and operation information.



When using a 2-cool, 3-heat thermostat both the W1 & W2 on the Heat Pump and W2 & EM on the thermostat must be connected together via a jumper. (See Figure#115)



Packaged heat pumps are equipped with detachable Thermostat connectors. These connectors are located in different locations based on the blower motor that is installed in the unit.

a) For the X13 motor, the two detachable connectors are on the Main Harness; connectors are marked as P1 and P2. See Wire Harness Drawing on Pg#72.

b) For the EON motor, the three detachable thermostat connectors are located on the ECM Interface board. See Wiring Harness Drawing on Pg#73.



Harness wiring can be loose, based on the options installed for the unit. See the Wiring Harness Drawing notes for further details.

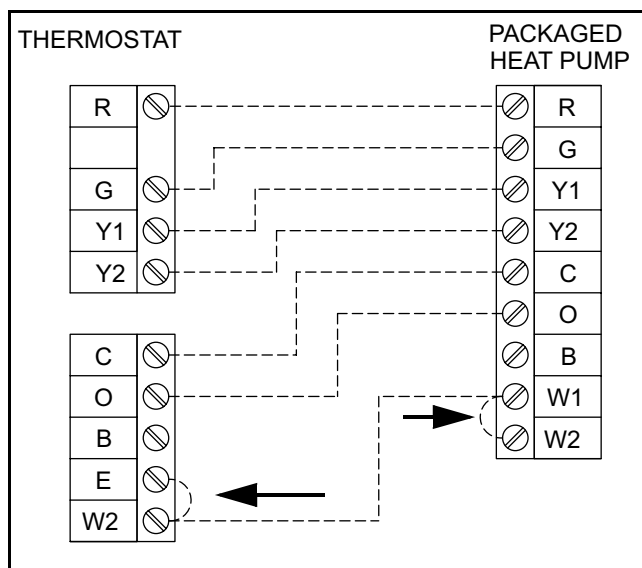

Figure # 115

OPERATING TEMPERATURES AND PRESSURES

Operating Temperatures and Pressures										
Model	Entering Water Temp. F	Water Flow GPM	COOLING				HEATING			
			Suction Pressure PSIG	Discharge Pressure PSIG	Water Temp Rise °F	Air Temp Drop °F	Suction Pressure PSIG	Discharge Pressure PSIG	Water Temp Drop °F	Air Temp Rise °F
SM024 Part Load	30°	3					76-96	242-282	4-8	16-20
		6					72-92	236-276	1-5	17-21
	40°	3					97-117	255-295	5-9	19-23
		6					93-113	249-289	2-6	20-24
	50°	3	140-160	171-211	14-18	21-25	117-137	270-310	6-10	21-25
		6	135-155	154-194	6-10	22-26	113-133	263-303	3-7	23-27
	60°	3	143-163	210-250	13-17	21-25	138-158	283-323	8-12	24-28
		6	138-158	191-231	6-10	21-25	134-154	276-316	3-7	26-30
	70°	3	146-166	249-289	13-17	20-24	159-179	298-338	9-13	27-31
		6	141-161	228-268	6-10	21-25	155-175	290-330	4-8	29-33
	80°	3	148-168	289-329	12-16	20-24	179-199	311-351	11-15	31-35
		6	143-163	264-304	5-9	20-24	175-195	303-343	5-9	33-37
	90°	3	151-171	328-368	12-16	19-23				
		6	146-166	301-341	5-9	19-23				
100°	3	154-174	367-407	11-15	18-22					
	6	149-169	337-377	5-9	19-23					
SM024 Full Load	30°	3					71-91	264-304	6-10	18-22
		6					67-87	258-298	3-7	19-23
	40°	3					131-151	135-175	8-12	20-24
		6					127-147	129-169	3-7	22-26
	50°	3	134-154	179-219	20-24	22-26	133-153	173-213	9-13	23-27
		6	129-149	166-206	9-13	23-27	129-149	166-206	4-8	25-29
	60°	3	136-156	219-259	19-23	21-25	135-155	211-251	11-15	26-30
		6	131-151	204-244	9-13	22-26	131-151	204-244	5-9	29-33
	70°	3	138-158	258-298	19-23	21-25	137-157	249-289	13-17	30-34
		6	133-153	241-281	9-13	21-25	133-153	241-281	6-10	32-36
	80°	3	140-160	298-338	18-22	20-24	139-159	287-327	15-19	33-37
		6	135-155	279-319	8-12	21-25	135-155	279-319	7-11	36-40
	90°	3	142-162	337-377	17-21	19-23				
		6	137-157	316-356	8-12	20-24				
100°	3	143-163	377-417	17-21	19-23					
	6	138-158	354-394	8-12	19-23					



This chart shows approximate temperatures and pressures for a unit in good repair. The values shown are meant as a guide only and should not be used to estimate system charge. This chart assumes rated air flow and 80° d.b./67° w.b. entering air temperature in cooling, 70° d.b. entering air temperature in heating. Heating data at entering fluid temperatures below 50° assumes the use of antifreeze. As a result of continuing research and development, specifications are subject to change without notice.

Operating Temperatures and Pressures										
Model	Entering Water Temp. F	Water Flow GPM	COOLING				HEATING			
			Suction Pressure PSIG	Discharge Pressure PSIG	Water Temp Rise °F	Air Temp Drop °F	Suction Pressure PSIG	Discharge Pressure PSIG	Water Temp Drop °F	Air Temp Rise °F
SM036 Part Load	30°	4,5					81-101	278-318	4-8	19-23
		9					77-97	272-312	1-5	20-24
	40°	4,5					97-117	294-334	5-9	22-26
		9					93-113	288-328	2-6	23-27
	50°	4,5	134-154	163-203	14-18	24-28	114-134	311-351	6-10	26-30
		9	129-149	149-189	6-10	25-29	110-130	304-344	2-6	27-31
	60°	4,5	136-156	202-242	13-17	23-27	131-151	327-367	7-11	29-33
		9	131-151	186-226	6-10	24-28	127-147	320-360	3-7	31-35
	70°	4,5	138-158	241-281	13-17	23-27	148-168	344-384	9-13	33-37
		9	133-153	223-263	5-9	23-27	144-164	336-376	4-8	35-39
	80°	4,5	140-160	280-320	12-16	22-26	165-185	360-400	10-14	36-40
		9	135-155	259-299	5-9	22-26	161-181	352-392	5-9	39-43
	90°	4,5	142-162	319-359	12-16	21-25				
		9	137-157	296-336	5-9	21-25				
SM036 Full Load	30°	4,5					75-95	287-327	6-10	20-24
		9					71-91	281-321	2-6	21-25
	40°	4,5					91-111	305-345	8-12	23-27
		9					87-107	299-339	3-7	24-28
	50°	4,5	128-148	178-218	20-24	24-28	107-127	322-362	9-13	26-30
		9	123-143	164-204	9-13	24-28	103-123	316-356	4-8	28-32
	60°	4,5	131-151	217-257	19-23	23-27	124-144	340-380	11-15	29-33
		9	126-146	201-241	9-13	24-28	120-140	334-374	5-9	32-36
	70°	4,5	133-153	257-297	19-23	23-27	140-160	358-398	13-17	33-37
		9	128-148	239-279	9-13	23-27	136-156	352-392	6-10	36-40
	80°	4,5	135-155	298-338	18-22	22-26	157-177	376-416	14-18	36-40
		9	130-150	277-317	8-12	22-26	153-173	370-410	7-11	40-44
	90°	4,5	138-158	337-377	18-22	21-25				
		9	133-153	314-354	8-12	22-26				
100°	4,5	140-160	377-417	17-21	21-25					
	9	135-155	352-392	8-12	21-25					



This chart shows approximate temperatures and pressures for a unit in good repair. The values shown are meant as a guide only and should not be used to estimate system charge. This chart assumes rated air flow and 80° d.b./ 67° w.b. entering air temperature in cooling, 70° d.b. entering air temperature in heating. Heating data at entering fluid temperatures below 50° assumes the use of antifreeze. As a result of continuing research and development, specifications are subject to change without notice.

Operating Temperatures and Pressures										
Model	Entering Water Temp. F	Water Flow GPM	COOLING				HEATING			
			Suction Pressure PSIG	Discharge Pressure PSIG	Water Temp Rise °F	Air Temp Drop °F	Suction Pressure PSIG	Discharge Pressure PSIG	Water Temp Drop °F	Air Temp Rise °F
SM048 Part Load	30°	6					75-95	259-299	4-8	16-20
		12					71-91	253-293	1-5	17-21
	40°	6					95-115	273-313	5-9	18-22
		12					91-111	267-307	2-6	20-24
	50°	6	137-157	175-215	14-18	28-32	116-136	288-328	6-10	21-25
		12	132-152	161-201	6-10	30-34	112-132	282-322	3-7	23-27
	60°	6	139-159	215-255	13-17	27-31	136-156	302-342	8-12	24-28
		12	134-154	199-239	6-10	28-32	132-152	296-336	3-7	26-30
	70°	6	141-161	255-295	13-17	25-29	157-177	317-357	9-13	27-31
		12	136-156	237-277	6-10	26-30	153-173	311-351	4-8	29-33
	80°	6	143-163	297-337	12-16	23-27	177-197	331-371	11-15	30-34
		12	138-158	276-316	5-9	24-28	173-193	325-365	5-9	33-37
	90°	6	145-165	337-377	12-16	22-26				
		12	140-160	314-354	5-9	23-27				
SM048 Full Load	30°	6					72-92	282-322	6-10	18-22
		12					68-88	276-316	2-6	19-23
	40°	6					91-111	298-338	8-12	21-25
		12					87-107	292-332	3-7	22-26
	50°	6	128-148	189-229	19-23	30-34	110-130	313-353	9-13	24-28
		12	123-143	175-215	9-13	32-36	106-126	307-347	4-8	26-30
	60°	6	130-150	231-271	19-23	29-33	128-148	329-369	11-15	27-31
		12	125-145	215-255	9-13	30-34	124-144	323-363	5-9	29-33
	70°	6	132-152	273-313	18-22	27-31	147-167	345-385	13-17	30-34
		12	127-147	255-295	8-12	29-33	143-163	339-379	6-10	33-37
	80°	6	134-154	315-355	18-22	26-30	166-186	361-401	15-19	34-38
		12	129-149	294-334	8-12	27-31	162-182	355-395	7-11	37-41
	90°	6	136-156	357-397	17-21	24-28				
		12	131-151	334-374	8-12	26-30				
100°	6	138-158	399-439	16-20	23-27					
	12	133-153	374-414	7-11	24-28					



This chart shows approximate temperatures and pressures for a unit in good repair. The values shown are meant as a guide only and should not be used to estimate system charge. This chart assumes rated air flow and 80° d.b./ 67° w.b. entering air temperature in cooling, 70° d.b. entering air temperature in heating. Heating data at entering fluid temperatures below 50° assumes the use of antifreeze. As a result of continuing research and development, specifications are subject to change without notice.

Model	Entering Water Temp. F	Water Flow GPM	COOLING				HEATING			
			Suction Pressure PSIG	Discharge Pressure PSIG	Water Temp Rise °F	Air Temp Drop °F	Suction Pressure PSIG	Discharge Pressure PSIG	Water Temp Drop °F	Air Temp Rise °F
SM060 Part Load	30°	7,5					77-97	268-308	4-8	17-21
		15					73-93	262-302	1-5	18-22
	40°	7,5					94-114	283-323	5-9	19-23
		15					90-110	277-317	2-6	21-25
	50°	7,5	137-157	173-213	14-18	29-33	111-131	298-338	7-11	22-26
		15	132-152	159-199	6-10	31-35	107-127	292-332	3-7	24-28
	60°	7,5	139-159	213-253	14-18	28-32	129-149	313-353	8-12	26-30
		15	134-154	197-237	6-10	29-33	125-145	307-347	3-7	27-31
	70°	7,5	141-161	253-293	13-17	26-30	146-166	328-368	10-14	29-33
		15	136-156	235-275	6-10	27-31	142-162	322-362	4-8	31-35
	80°	7,5	143-163	294-334	12-16	24-28	164-184	343-383	11-15	32-36
		15	138-158	273-313	5-9	25-29	160-180	337-377	5-9	35-39
	90°	7,5	145-165	334-374	12-16	23-27				
		15	140-160	311-351	5-9	24-28				
100°	7,5	147-167	374-414	11-15	21-25					
	15	142-162	349-389	5-9	22-26					
SM060 Full Load	30°	7,5					71-91	293-333	7-11	19-23
		15					67-87	287-327	3-7	20-24
	40°	7,5					89-109	311-351	8-12	22-26
		15					85-105	305-345	3-7	23-27
	50°	7,5	126-146	185-225	20-24	31-35	106-126	329-369	10-14	25-29
		15	121-141	171-211	9-13	32-36	102-122	323-363	4-8	27-31
	60°	7,5	128-148	226-266	19-23	29-33	124-144	347-387	11-15	28-32
		15	123-143	210-250	9-13	31-35	120-140	341-381	5-9	30-34
	70°	7,5	130-150	267-307	19-23	28-32	142-162	365-405	13-17	31-35
		15	125-145	249-289	9-13	29-33	138-158	359-399	6-10	34-38
	80°	7,5	132-152	309-349	18-22	27-31	160-180	383-423	15-19	35-39
		15	127-147	288-328	8-12	28-32	156-176	377-417	8-12	38-42
	90°	7,5	134-154	350-390	17-21	25-29				
		15	129-149	327-367	8-12	26-30				
100°	7,5	135-155	391-431	17-21	24-28					
	15	130-150	366-406	8-12	25-29					



This chart shows approximate temperatures and pressures for a unit in good repair. The values shown are meant as a guide only and should not be used to estimate system charge. This chart assumes rated air flow and 80° d.b./67° w.b. entering air temperature in cooling, 70° d.b. entering air temperature in heating. Heating data at entering fluid temperatures below 50° assumes the use of antifreeze. As a result of continuing research and development, specifications are subject to change without notice.

Model	Entering Water Temp. F	Water Flow GPM	COOLING				HEATING			
			Suction Pressure PSIG	Discharge Pressure PSIG	Water Temp Rise °F	Air Temp Drop °F	Suction Pressure PSIG	Discharge Pressure PSIG	Water Temp Drop °F	Air Temp Rise °F
SM070 Part Load	30°	9.0					72-92	267-307	4-8	17-21
		18.0					68-88	261-301	1-5	18-22
	40°	9.0					91-111	283-323	5-9	20-24
		18.0					87-107	277-317	2-6	21-25
	50°	9.0	130-150	173-213	14-18	29-33	109-129	299-339	6-10	23-27
		18.0	125-145	159-199	6-10	31-35	105-125	293-333	3-7	25-29
	60°	9.0	132-152	213-253	13-17	28-32	128-148	315-355	8-12	26-30
		18.0	127-147	197-237	6-10	29-33	124-144	309-349	3-7	27-31
	70°	9.0	134-154	253-293	13-17	26-30	147-167	331-371	9-13	30-34
		18.0	129-149	235-275	6-10	28-32	143-163	325-365	4-8	32-36
	80°	9.0	137-157	294-334	12-16	25-29	165-185	347-387	11-15	34-38
		18.0	132-152	273-313	5-9	26-30	161-181	341-381	5-9	36-40
	90°	9.0	139-159	334-374	12-16	23-27				
		18.0	134-154	311-351	5-9	24-28				
100°	9.0	142-162	374-414	11-15	22-26					
	18.0	137-157	349-389	5-9	23-27					
SM070 Full Load	30°	9.0					69-89	289-329	6-10	18-22
		18.0					65-85	283-323	2-6	20-24
	40°	9.0					85-105	307-347	7-11	21-25
		18.0					81-101	301-341	3-7	23-27
	50°	9.0	123-143	185-225	18-22	29-33	101-121	325-365	9-13	24-28
		18.0	118-138	171-211	9-13	31-35	97-117	319-359	4-8	26-30
	60°	9.0	125-145	226-266	18-22	28-32	118-138	342-382	11-15	27-31
		18.0	120-140	210-250	8-12	29-33	114-134	336-376	5-9	29-33
	70°	9.0	127-147	268-308	17-21	27-31	134-154	360-400	12-16	31-35
		18.0	122-142	250-290	8-12	28-32	130-150	354-394	6-10	34-38
	80°	9.0	130-150	311-351	17-21	25-29	151-171	378-418	14-18	34-38
		18.0	125-145	290-330	8-12	27-31	147-167	372-412	7-11	38-42
	90°	9.0	132-152	353-393	16-20	24-28				
		18.0	127-147	330-370	7-11	25-29				
100°	9.0	134-154	394-434	16-20	23-27					
	18.0	129-149	369-409	7-11	24-28					



This chart shows approximate temperatures and pressures for a unit in good repair. The values shown are meant as a guide only and should not be used to estimate system charge. This chart assumes rated air flow and 80° d.b./ 67° w.b. entering air temperature in cooling, 70° d.b. entering air temperature in heating. Heating data at entering fluid temperatures below 50° assumes the use of antifreeze. As a result of continuing research and development, specifications are subject to change without notice.

AIRFLOW TABLES

Constant Torque Motor Airflow Table (SM0**.*-***-***-**I***)

ECM Const Torque Motor - X13															
Models	Fan Speed	Rated Airflow	Factory setting	External Static Pressure (in of Water)											
				0.10	0.20	0.30	0.40	0.50	0.60	0.70	0.80	0.90	1.00	1.10	1.20
SM024	5	950		1154	1117	1077	1034	988	938	886	830	-	-	-	-
	4	825	FL	1072	1018	966	915	866	818	772	727	-	-	-	-
	3	725		976	920	867	815	766	719	674	631	-	-	-	-
	2	650	PL/Fan only	906	844	785	730	678	630	585	544	-	-	-	-
	1	500		829	750	676	610	551	498	451	412	-	-	-	-
SM036	5	1300		1506	1469	1430	1390	1347	1300	1249	1193	1130	1061	-	-
	4	1100	FL	1425	1326	1250	1191	1143	1100	1056	1006	942	860	-	-
	3	950		1354	1233	1138	1063	1002	950	901	850	791	719	-	-
	2	800	PL/Fan only	1294	1157	1041	946	866	800	744	696	653	611	-	-
	1	750		1213	1084	976	886	812	750	698	653	612	573		
SM048	5	1800		1950	1912	1880	1852	1826	1800	1771	1737	1695	1644	-	-
	4	1600	FL	1774	1738	1703	1669	1635	1600	1562	1521	1475	1423	-	-
	3	1400		1565	1526	1493	1463	1432	1400	1363	1319	1265	1199	-	-
	2	1300	PL/Fan only	1506	1469	1430	1390	1347	1300	1249	1193	1130	1061	-	-
	1	1100		1425	1326	1250	1191	1143	1100	1056	1006	942	860	-	-
SM060	5	2200		2476	2403	2338	2283	2237	2200	2172	2153	2142	2141	2149	2166
	4	2000	FL	2170	2135	2100	2066	2033	2000	1968	1937	1907	1877	1848	1819
	3	1800		1942	1914	1886	1858	1829	1800	1770	1741	1710	1680	1649	1617
	2	1600	PL/Fan only	1766	1729	1693	1660	1629	1600	1573	1548	1526	1505	1487	1470
	1	1400		1561	1520	1483	1451	1423	1400	1381	1366	1356	1350	1349	1352
SM070	5	2500		2723	2671	2622	2578	2537	2500	2467	2437	2412	2390	2372	2358
	4	2350	FL	2566	2529	2489	2446	2399	2350	2298	2242	2184	2122	2057	1990
	3	2100		2256	2230	2202	2171	2137	2100	2060	2017	1971	1922	1871	1816
	2	1850	PL/Fan only	2004	1975	1945	1915	1883	1850	1816	1781	1745	1708	1669	1630
	1	1600		1766	1728	1693	1660	1629	1600	1573	1548	1526	1505	1486	1470

FL Full Load
PL Part Load

**CONSTANT AIRFLOW MOTOR AIRFLOW
TABLE(SM0**-***-***-A)**

ECM Const CFM Motor - EON														
Models	Fan Speed	Rated Airflow	Adjust	Tap	External Static Pressure (in of Water)									
					0.10	0.20	0.30	0.40	0.50	0.60	0.70	0.80	0.90	1.00
SM024 Part Load	Hi	725	+	A	725	725	725	725	725	725	725	725	-	-
	Med	650	Normal	A	650	650	650	650	650	650	650	650	-	-
	Low	500	-	A	500	500	500	500	500	500	500	500	-	-
SM024 Full Load	Hi	950	+	A	950	950	950	950	950	950	950	950	-	-
	Med	825	Normal	A	825	825	825	825	825	825	825	825	-	-
	Low	725	-	A	725	725	725	725	725	725	725	725	-	-
SM036 Part Load	Hi	950	+	A	950	950	950	950	950	950	950	950	950	950
	Med	800	Normal	A	800	800	800	800	800	800	800	800	800	800
	Low	750	-	A	750	750	750	750	750	750	750	750	750	750
SM036 Full Load	Hi	1300	+	A	1300	1300	1300	1300	1300	1300	1300	1300	1300	1300
	Med	1100	Normal	A	1100	1100	1100	1100	1100	1100	1100	1100	1100	1100
	Low	950	-	A	950	950	950	950	950	950	950	950	950	950
SM048 Part Load	Hi	1400	+	A	1400	1400	1400	1400	1400	1400	1400	1400	1400	1400
	Med	1300	Normal	A	1300	1300	1300	1300	1300	1300	1300	1300	1300	1300
	Low	1100	-	A	1100	1100	1100	1100	1100	1100	1100	1100	1100	1100
SM048 Full Load	Hi	1800	+	A	1800	1800	1800	1800	1800	1800	1800	1800	1800	1800
	Med	1600	Normal	A	1600	1600	1600	1600	1600	1600	1600	1600	1600	1600
	Low	1400	-	A	1400	1400	1400	1400	1400	1400	1400	1400	1400	1400
SM060 Part Load	Hi	1800	+	A	1800	1800	1800	1800	1800	1800	1800	1800	1800	1800
	Med	1600	Normal	A	1600	1600	1600	1600	1600	1600	1600	1600	1600	1600
	Low	1400	-	A	1400	1400	1400	1400	1400	1400	1400	1400	1400	1400
SM060 Full Load	Hi	2200	+	A	2200	2200	2200	2200	2200	2200	2200	2200	2200	2200
	Med	2000	Normal	A	2000	2000	2000	2000	2000	2000	2000	2000	2000	2000
	Low	1800	-	A	1800	1800	1800	1800	1800	1800	1800	1800	1800	1800
SM070 Part Load	Hi	2100	+	A	2100	2100	2100	2100	2100	2100	2100	2100	2100	2100
	Med	1850	Normal	A	1850	1850	1850	1850	1850	1850	1850	1850	1850	1850
	Low	1600	-	A	1600	1600	1600	1600	1600	1600	1600	1600	1600	1600
SM070 Full Load	Hi	2500	+	A	2500	2500	2500	2500	2500	2500	2500	2500	2500	2500
	Med	2350	Normal	A	2350	2350	2350	2350	2350	2350	2350	2350	2350	2350
	Low	2100	-	A	2100	2100	2100	2100	2100	2100	2100	2100	2100	2100

WATER SIDE PRESSURE DROP TABLE

Water Side Pressure Drop Table			
Model	GPM	Heat Pump water pressure drop	Additional pressure drop in hose kit*
		Water PD @ 77°EWT with Water in Psi	Water PD in Psi
SM024	3	0.7	0.04
	4	1.2	0.04
	5	1.7	0.09
	6	2.4	0.09
	7	3.2	0.13
	8	4.0	0.17
SM036	4.5	1.3	0.09
	6	2.2	0.09
	7.5	3.2	0.17
	9	4.5	0.22
	10.5	5.9	0.30
	12	7.5	0.35
SM048	6	1.1	0.09
	8	1.8	0.17
	10	2.7	0.26
	12	3.7	0.35
	14	4.9	0.48
	16	6.2	0.61
SM060	7.5	1.1	0.17
	10	1.9	0.26
	12.5	2.8	0.39
	15	3.9	0.52
	17.5	5.2	0.69
	20	6.6	0.91
SM070	9	0.9	0.22
	12	1.4	0.35
	15	2.1	0.52
	18	3.0	0.74
	21	3.9	0.95
	24	5.0	1.21

* Hose kit pressure drop based on straight hose. Pressure drop may vary depending on installation of hose kits.

WIRING DIAGRAMS

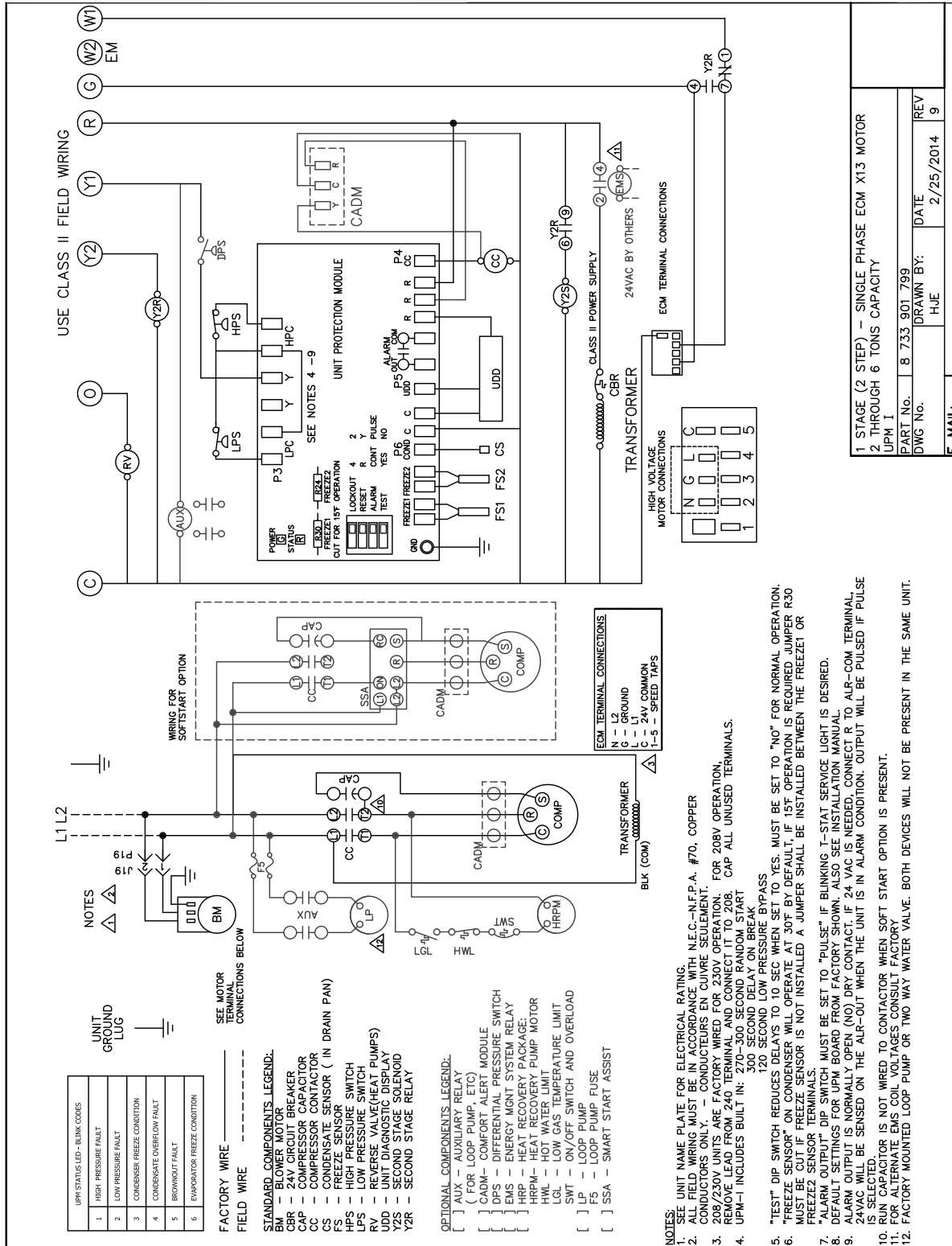

Figure # 116



NOTE: FOR REFERENCE ONLY Actual unit wiring may vary from this example. Always refer to the wiring diagram attached to the unit

1 STAGE (2 STEP) - SINGLE PHASE ECM X13 MOTOR			
2 THROUGH 6 TONS CAPACITY			
UPM 1		DATE	
DWG No.	8 733 901 799	DRAWN BY:	REV
		HJE	9
E-MAIL:		2/25/2014	

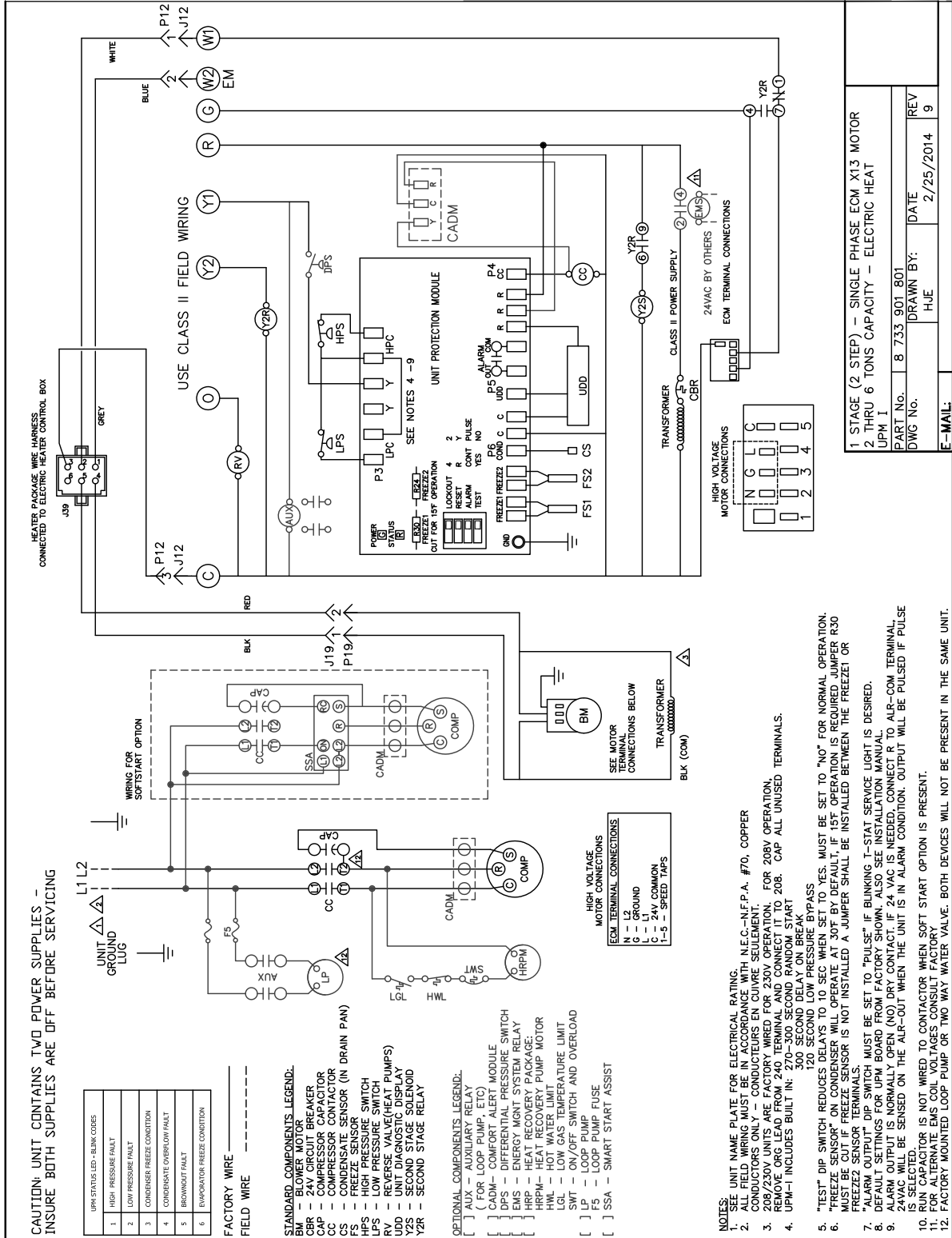

Figure # 118



NOTE: FOR REFERENCE ONLY Actual unit wiring may vary from this example. Always refer to the wiring diagram attached to the unit.

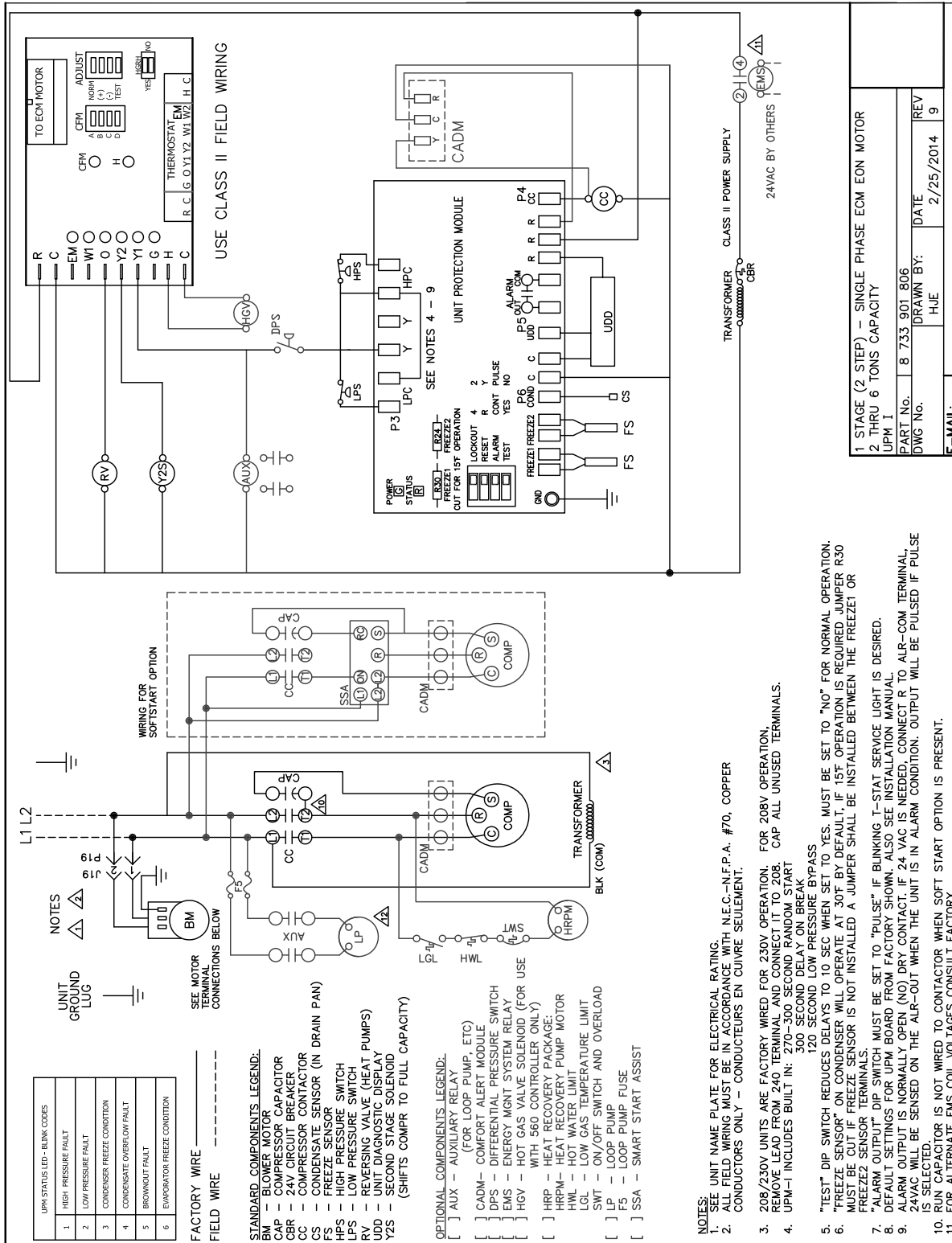

Figure # 119



NOTE: FOR REFERENCE ONLY Actual unit wiring may vary from this example. Always refer to the wiring diagram attached to the unit.

1 STAGE (2 STEP) - SINGLE PHASE ECM ECM MOTOR	
2 THRU 6 TONS CAPACITY	
UPM I	
PART No.	8 733 901 806
DWG No.	HJE
DATE	2/25/2014
REV	9
E-MAIL:	

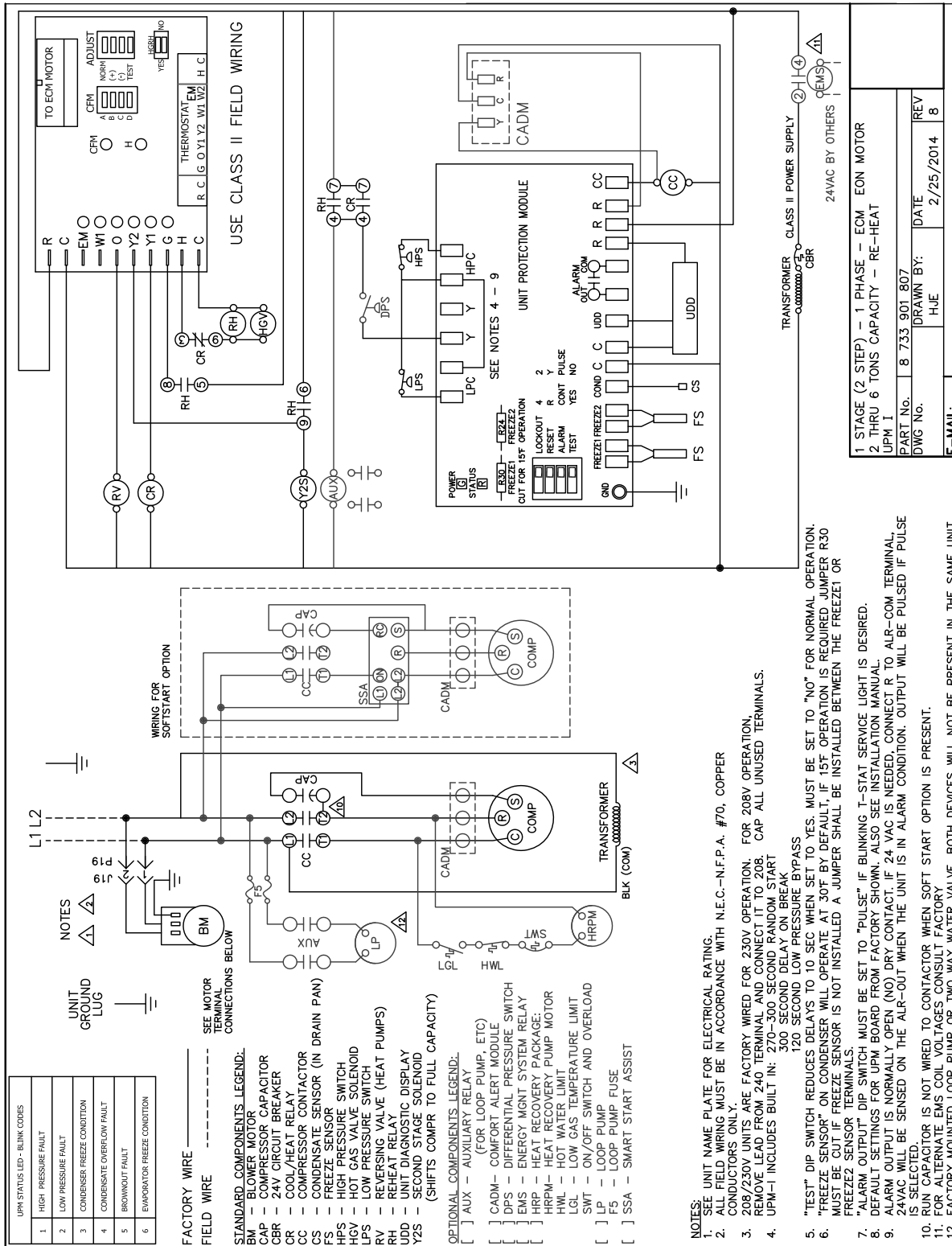

Figure # 120



NOTE: FOR REFERENCE ONLY Actual unit wiring may vary from this example. Always refer to the wiring diagram attached to the unit.

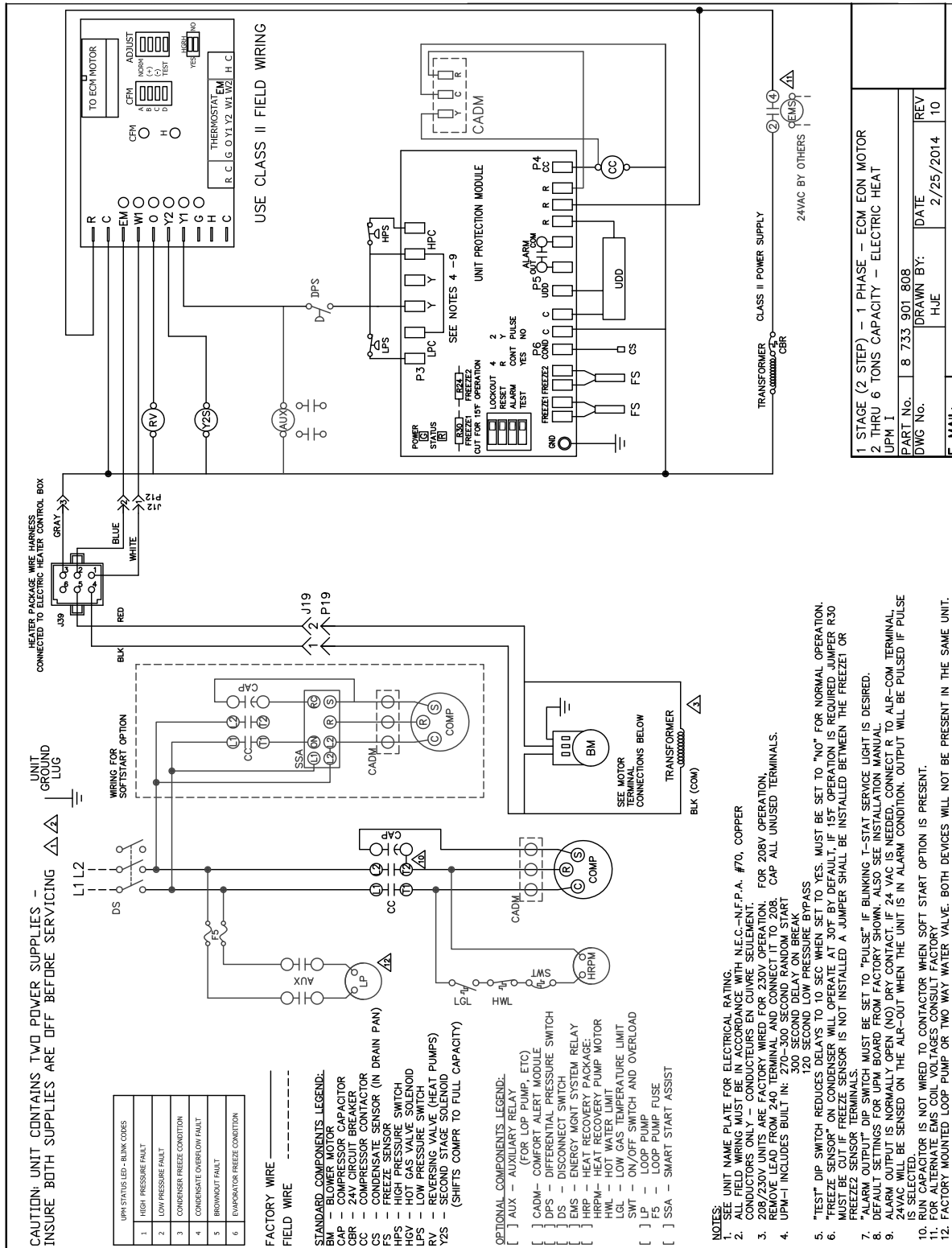

Figure # 121



NOTE: FOR REFERENCE ONLY Actual unit wiring may vary from this example. Always refer to the wiring diagram attached to the unit.

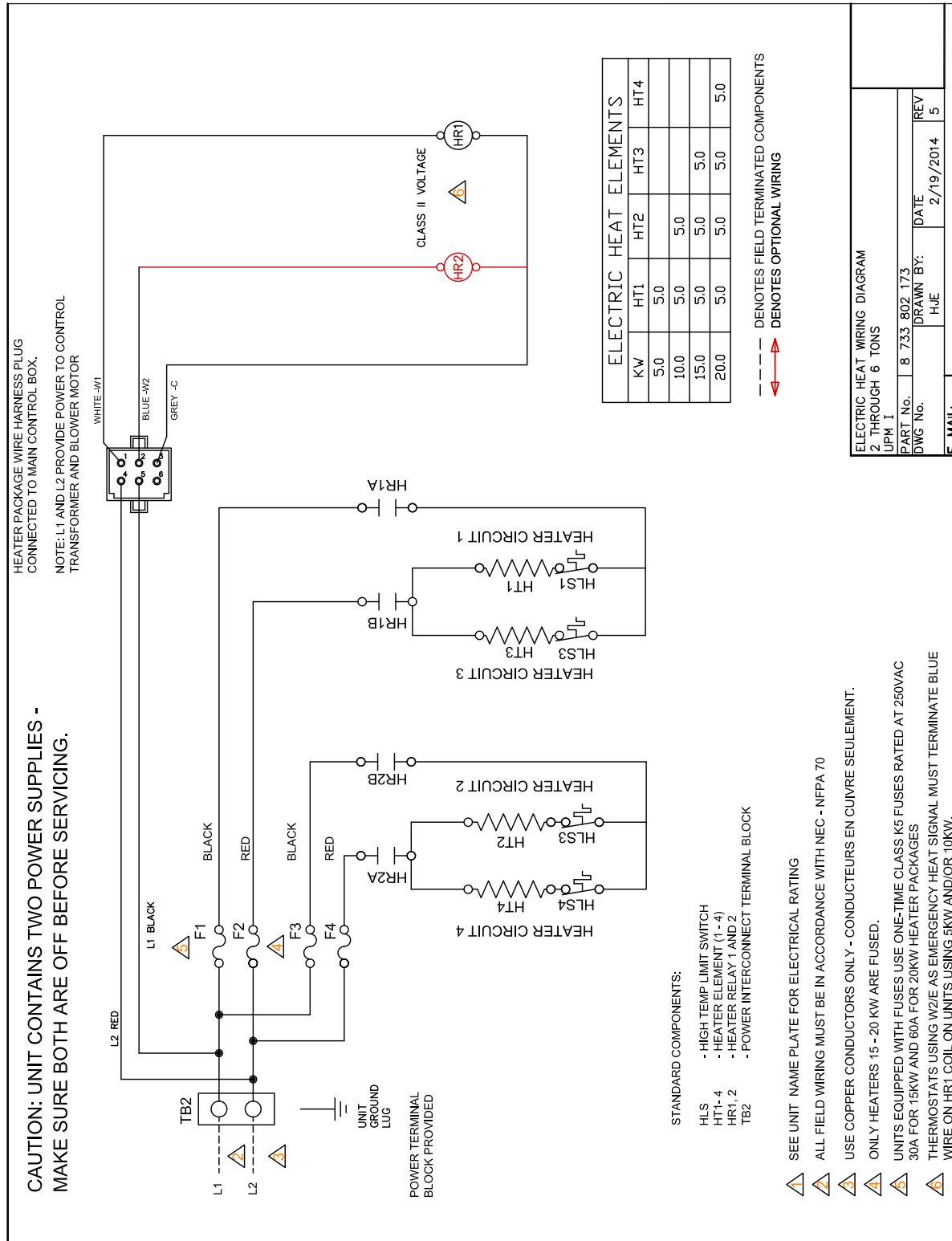

Figure # 122



NOTE: FOR REFERENCE ONLY Actual unit wiring may vary from this example. Always refer to the wiring diagram attached to the unit.

WIRING HARNESS DRAWINGS

Constant Torque Motor (SM0**-***-***-1*)

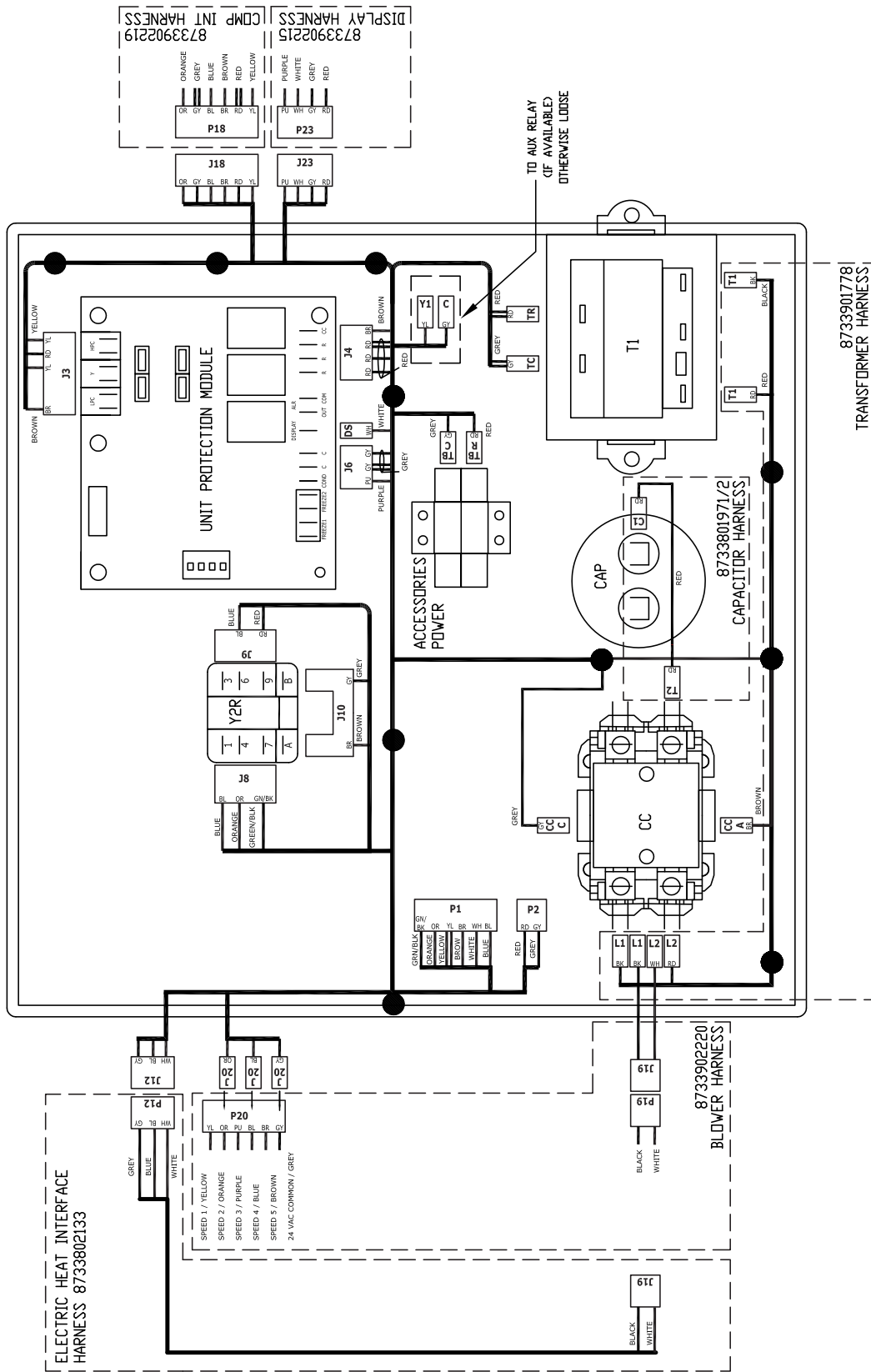

Figure # 123

SPARE PARTS LIST

This section is divided into three parts: Vertical (VT), Counter Flow (CF) and Horizontal (HZ). Each section is started with kit names and part numbers, followed by exploded view illustration identifying all the available components, assemblies and kits.

Vertical (VT)

VERTICAL CONFIGURATION - PARTS LIST											
Item	Description	SM024-1VTC	SM036-1VTC	SM048-1VTC	SM060-1VTC	SM070-1VTC	SM024-1VTN	SM036-1VTN	SM048-1VTN	SM060-1VTN	SM070-1VTN
1	Floating Base Pan Kit	8733802642	8733802642	8733802642	8733802642	8733802642	8733802642	8733802642	8733802642	8733802642	8733802642
2	Water Coil Kit	8733802643	8733802715	8733802716	8733802717	8733802718	8733802719	8733802720	8733802721	8733802722	8733802723
3	Small Vertical Post Kit	8733802644	8733802724	8733802724	8733802725	8733802725	8733802644	8733802724	8733802724	8733802725	8733802725
4	Wide LH Vertical Post Kit	8733802645	8733802726	8733802726	8733802727	8733802727	8733802645	8733802726	8733802726	8733802727	8733802727
5	Wide RH Vertical Post Kit	8733802646	8733802728	8733802728	8733802729	8733802729	8733802646	8733802728	8733802728	8733802729	8733802729
6	Black Nylon Plug Kit	8733802647	8733802647	8733802647	8733802647	8733802647	8733802647	8733802647	8733802647	8733802647	8733802647
7	Compressor Kit	8733802648	8733802730	8733802731	8733802732	8733802733	8733802648	8733802730	8733802731	8733802732	8733802733
8	Reversing Valve Kit	8733802649	8733802734	8733802735	8733802735	8733802735	8733802649	8733802734	8733802735	8733802735	8733802735
9	Filter Drier Kit	8733802650	8733802650	8733802650	8733802650	8733802650	8733802650	8733802650	8733802650	8733802650	8733802650
10	Lo Pressure Switch Kit	8733802651	8733802651	8733802651	8733802651	8733802651	8733802651	8733802651	8733802651	8733802651	8733802651
11	Hi Pressure Switch Kit	8733802652	8733802652	8733802652	8733802652	8733802652	8733802652	8733802652	8733802652	8733802652	8733802652
12	Drain Pan Assy Kit	8733802653	8733802736	8733802736	8733802736	8733802736	8733802653	8733802736	8733802736	8733802736	8733802736
13	Air Coil Kit	8733802654	8733802737	8733802738	8733802844	8733802740	8733802654	8733802737	8733802738	8733802844	8733802740
14	TXV Kit	8733802655	8733802741	8733802742	8733802743	8733802744	8733802655	8733802741	8733802742	8733802743	8733802744
15	Reinforcing Bracket Kit	8733802656	8733802656	8733802656	8733802656	8733802656	8733802656	8733802656	8733802656	8733802656	8733802656
16	Blower Kit	8733802657	8733802745	8733802745	8733802746	8733802746	8733802657	8733802745	8733802745	8733802746	8733802746
17	HZ Blower mounting Bracket Kit	8733802658	8733802658	8733802658	8733802747	8733802747	8733802658	8733802658	8733802658	8733802747	8733802747
18	Vert. Blower Mounting Bracket KIT	8733802659	8733802748	8733802748	8733802748	8733802748	8733802659	8733802748	8733802748	8733802748	8733802748
19	Constant Torque ECM Motor Kit	8733802660	8733802749	8733802750	8733802751	8733802752	8733802660	8733802749	8733802750	8733802751	8733802752
20	Motor Mounting Kit	8733802661	8733802661	8733802661	8733802661	8733802661	8733802661	8733802661	8733802661	8733802661	8733802661
21	Heater Collar Kit	8733802662	8733802753	8733802753	8733802754	8733802754	8733802662	8733802753	8733802753	8733802754	8733802754
22	# Condensate Drain Kit	8733802663	8733802663	8733802663	8733802663	8733802663	8733802663	8733802663	8733802663	8733802663	8733802663
23	Condensate Sensor Kit	8733802664	8733802664	8733802664	8733802664	8733802664	8733802664	8733802664	8733802664	8733802664	8733802664
24	* EBOX Kit	8733802665	8733802756	8733802757	8733802758	8733802758	8733802665	8733802756	8733802757	8733802758	8733802758
25	# Relay Kit	8733802666	8733802666	8733802666	8733802666	8733802666	8733802666	8733802666	8733802666	8733802666	8733802666
26	# Contactor Kit	8733802667	8733802667	8733802667	8733802667	8733802667	8733802667	8733802667	8733802667	8733802667	8733802667
27	# Capacitor Kit	8733802668	8733802759	8733802760	8733802761	8733802761	8733802668	8733802759	8733802760	8733802761	8733802761
28	# Transformer Kit	8733802669	8733802669	8733802669	8733802669	8733802669	8733802669	8733802669	8733802669	8733802669	8733802669
29	# UPM Kit	8733802670	8733802670	8733802670	8733802670	8733802670	8733802670	8733802670	8733802670	8733802670	8733802670
30	# Main Harness Kit	8733802671	8733802671	8733802671	8733802671	8733802671	8733802671	8733802671	8733802671	8733802671	8733802671
31	# Compressor Plug Kit - Hi voltage	8733802672	8733802672	8733802672	8733802672	8733802672	8733802672	8733802672	8733802672	8733802672	8733802672
32	# Blower Harness Kit	8733802673	8733802673	8733802673	8733802673	8733802673	8733802673	8733802673	8733802673	8733802673	8733802673
33	# Display Harness Kit	8733802674	8733802674	8733802674	8733802674	8733802674	8733802674	8733802674	8733802674	8733802674	8733802674
34	# Transformer Harness Kit	8733802675	8733802675	8733802675	8733802675	8733802675	8733802675	8733802675	8733802675	8733802675	8733802675
35	# Condensator Interface Harness Kit	8733802676	8733802676	8733802676	8733802676	8733802676	8733802676	8733802676	8733802676	8733802676	8733802676
36	Top Panel Assy Kit	8733802677	8733802762	8733802762	8733802763	8733802763	8733802677	8733802762	8733802762	8733802763	8733802763
37	Belt Panel Kit	8733802678	8733802764	8733802764	8733802765	8733802765	8733802678	8733802764	8733802764	8733802765	8733802765
38	* Upper Panel Assy Kit	8733802679	8733802766	8733802766	8733802767	8733802767	8733802679	8733802766	8733802766	8733802767	8733802767

39	Clip Kit	8733802680	8733802680	8733802680	8733802680	8733802680	8733802680	8733802680	8733802680	8733802680	8733802680
40	* Upper Panel Blower Kit	8733802681	8733802768	8733802768	8733802769	8733802769	8733802681	8733802768	8733802768	8733802769	8733802769
41	* Logo Panel Kit	8733802682	8733802770	8733802770	8733802771	8733802771	8733802682	8733802770	8733802770	8733802771	8733802771
42	* Lower Panel Access Kit	8733802683	8733802772	8733802772	8733802774	8733802774	8733802683	8733802772	8733802772	8733802774	8733802774
43	Lower Panel Kit	8733803600	8733803601	8733803601	8733803602	8733803602	8733803600	8733803601	8733803601	8733803602	8733803602
44	Blower Cover Kit	8733802684	8733802775	8733802775	8733802776	8733802776	8733802684	8733802775	8733802775	8733802776	8733802776
45	Filter Rack Assy Kit	8733802685	8733802777	8733802777	8733802778	8733802778	8733802685	8733802777	8733802777	8733802778	8733802778
46	Display Kit	8733802686	8733802686	8733802686	8733802686	8733802686	8733802686	8733802686	8733802686	8733802686	8733802686
47	MERV-11 Filter Kit	8733802687	8733802779	8733802779	8733802780	8733802780	8733802687	8733802779	8733802779	8733802780	8733802780
48	Corner Cap Kit	8733802688	8733802781	8733802781	8733802782	8733802782	8733802688	8733802781	8733802781	8733802782	8733802782
49	Freeze sensor Kit	8733802689	8733802689	8733802689	8733802783	8733802783	8733802689	8733802689	8733802689	8733802783	8733802783
53	# Constant Airflow ECM Motor Kit	8733802693	8733802784	8733802785	8733802786	8733802787	8733802693	8733802784	8733802785	8733802786	8733802787
54	# Constant Airflow ECM Board Kit	8733802694	8733802694	8733802694	8733802694	8733802694	8733802694	8733802694	8733802694	8733802694	8733802694
55	# Constant Airflow ECM Harness Kit	8733802695	8733802695	8733802695	8733802695	8733802695	8733802695	8733802695	8733802695	8733802695	8733802695
57	DPS Switch Kit	8733802697	8733802697	8733802697	8733802697	8733802697	8733802697	8733802697	8733802697	8733802697	8733802697
59	# HRP Relay Kit	8733802698	8733802698	8733802698	8733802698	8733802698	8733802698	8733802698	8733802698	8733802698	8733802698
59	HRP Switch Kit	8733802699	8733802699	8733802699	8733802699	8733802699	8733802699	8733802699	8733802699	8733802699	8733802699
60	# HRP Water Temp Sensor Kit	8733802700	8733802700	8733802700	8733802700	8733802700	8733802700	8733802700	8733802700	8733802700	8733802700
62	HRP Coil Kit	8733802702	8733802702	8733802788	8733802788	8733802788	8733802702	8733802702	8733802788	8733802788	8733802788
63	HRP Pump Kit	8733802703	8733802703	8733802703	8733802703	8733802703	8733802703	8733802703	8733802703	8733802703	8733802703
64	HGRH Coil Kit	8733802704	8733802789	8733802789	8733802790	8733802790	8733802704	8733802789	8733802789	8733802790	8733802790
65	Reheat Valve Kit	-	8733802705	8733802705	8733802705	8733802705	-	8733802705	8733802705	8733802705	8733802705
66	HGRH Small Check Valve Kit	-	8733802706	8733802706	8733802706	8733802706	-	8733802706	8733802706	8733802706	8733802706
67	HGRH Big Check Valve Kit	-	8733802707	8733802707	8733802707	8733802707	-	8733802707	8733802707	8733802707	8733802707
68	HGRH Top Panel Kit	-	8733802708	8733802708	8733802792	8733802792	-	8733802708	8733802708	8733802792	8733802792
69	# HGRH Main Harness Kit	-	8733802709	8733802709	8733802709	8733802709	-	8733802709	8733802709	8733802709	8733802709
70	# Comfort Alert Module Kit	8733802710	8733802710	8733802710	8733802710	8733802710	8733802710	8733802710	8733802710	8733802710	8733802710
71	# 5kW EH Element Kit	8733802711	8733802711	8733802711	8733802711	8733802711	8733802711	8733802711	8733802711	8733802711	8733802711
72	5kW EH Cntrl Box KIT	8733802712	8733802712	8733802712	8733802712	8733802712	8733802712	8733802712	8733802712	8733802712	8733802712
73	# 5kW EH Contactor Kit	8733802713	8733802713	8733802713	8733802713	8733802713	8733802713	8733802713	8733802713	8733802713	8733802713
74	# 10kW EH Element Kit	-	8733802793	8733802793	8733802793	8733802793	-	8733802793	8733802793	8733802793	8733802793
75	# 10kW EH Cntrl Box KIT	-	8733802794	8733802794	8733802794	8733802794	-	8733802794	8733802794	8733802794	8733802794
76	# 10kW EH Contactor Kit	-	8733802795	8733802795	8733802795	8733802795	-	8733802795	8733802795	8733802795	8733802795
77	# 15kW EH Element Kit	-	-	8733802796	8733802796	8733802796	-	-	8733802796	8733802796	8733802796
78	# 15kW EH Cntrl Box KIT	-	-	8733802797	8733802797	8733802797	-	-	8733802797	8733802797	8733802797
79	# 15kW EH Fuse Box Kit	-	-	8733802798	8733802798	8733802798	-	-	8733802798	8733802798	8733802798
80	# 15kW EH Contactor Kit	-	-	-	8733802799	8733802799	-	-	-	8733802799	8733802799
81	# 20kW EH Element Kit	-	-	-	8733802800	8733802800	-	-	-	8733802800	8733802800
82	# 20kW EH Cntrl Box KIT	-	-	-	8733802801	8733802801	-	-	-	8733802801	8733802801
83	# 20kW EH Fuse Box Kit	-	-	-	8733802802	8733802802	-	-	-	8733802802	8733802802
84	# 20kW EH Contactor Kit	-	-	-	8733802803	8733802803	-	-	-	8733802803	8733802803
85	# HGRH + ECM constant air flow Harness Kit	-	8733802714	8733802714	8733802714	8733802714	-	8733802714	8733802714	8733802714	8733802714
86	Water Piping Kit	8733803577	8733803578	8733803579	8733803585	8733803586	8733803577	8733803578	8733803579	8733803585	8733803586
87	Rubber Bushing kit	8733803587	8733803587	8733803587	8733803587	8733803587	8733803587	8733803587	8733803587	8733803587	8733803587
88	HRP Water pipe kit	8733804632	8733804633	8733804633	8733804634	8733804634	8733804632	8733804633	8733804633	8733804634	8733804634
107	# Constant Airflow Blower Power Harness Kit	8733904563	8733904563	8733904563	8733904563	8733904563	8733904563	8733904563	8733904563	8733904563	8733904563
109	Handle Plastic Kit	8733803589	8733803589	8733803589	8733803589	8733803589	8733803589	8733803589	8733803589	8733803589	8733803589

not shown in drawing

* Detailed view available

All refrigerant circuit components kit includes filter drier

VT Parts List - Cabinet

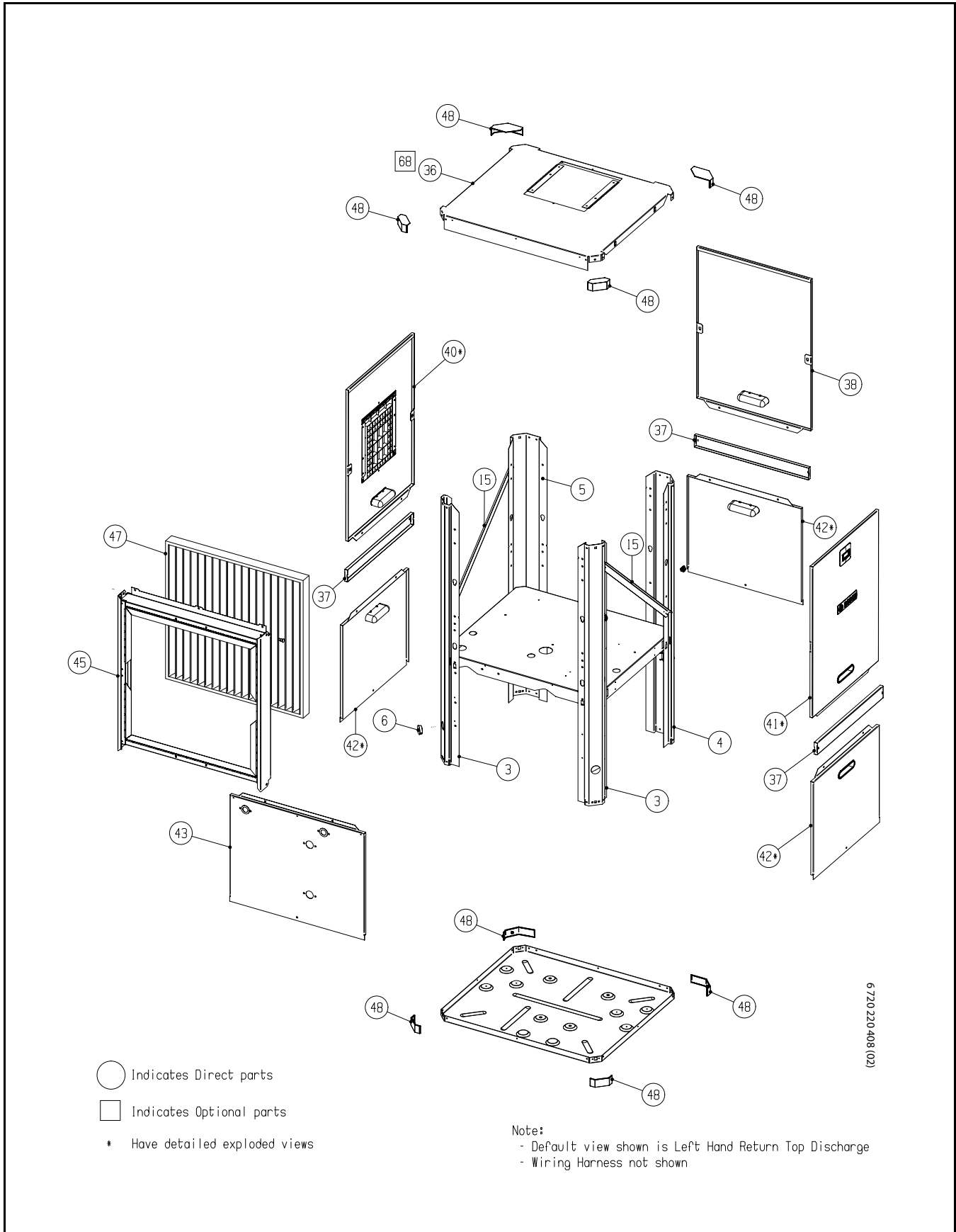

Figure # 125

VT Parts List - Blower

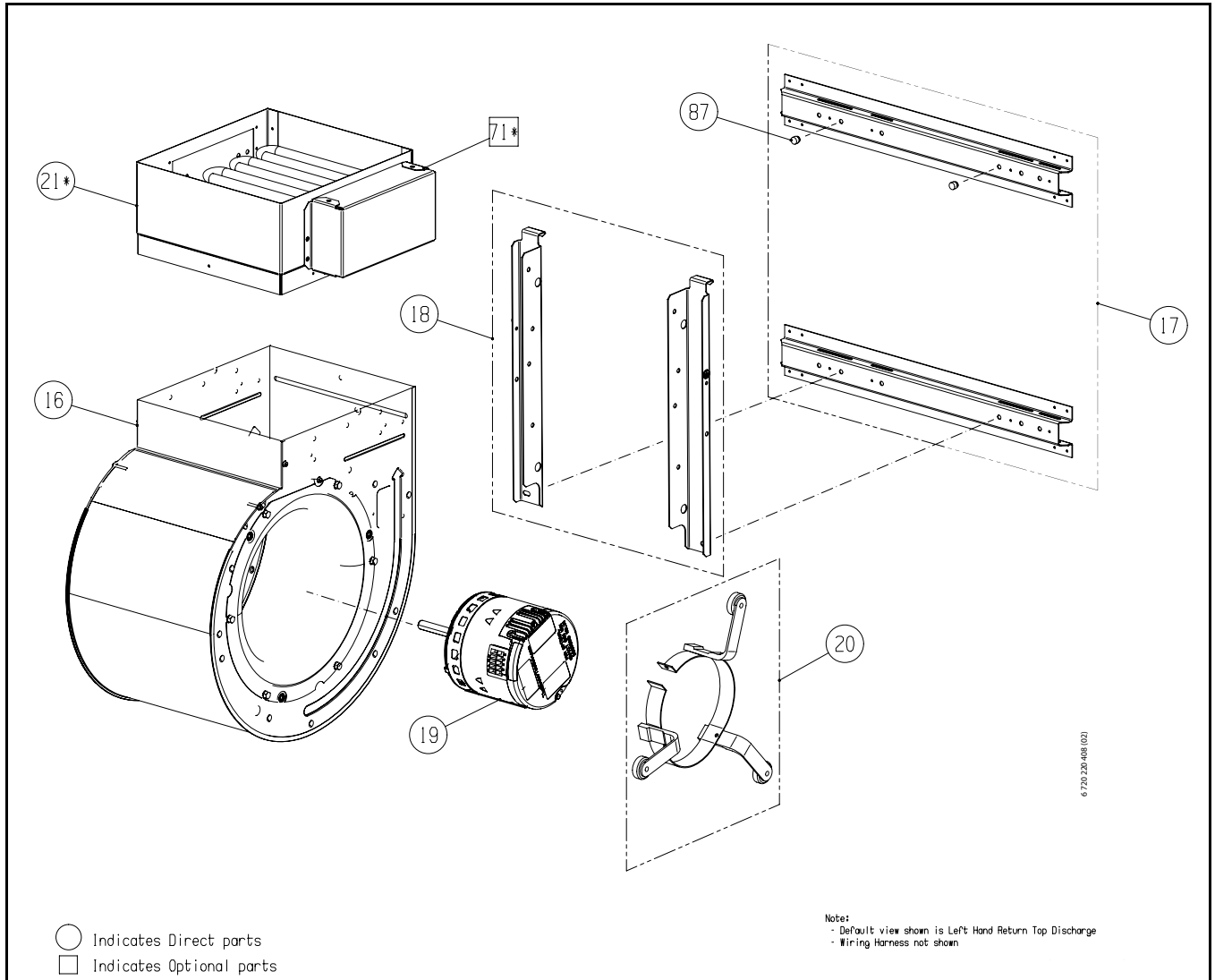

Figure # 126

VT Parts List -Refrigeration and Electrical

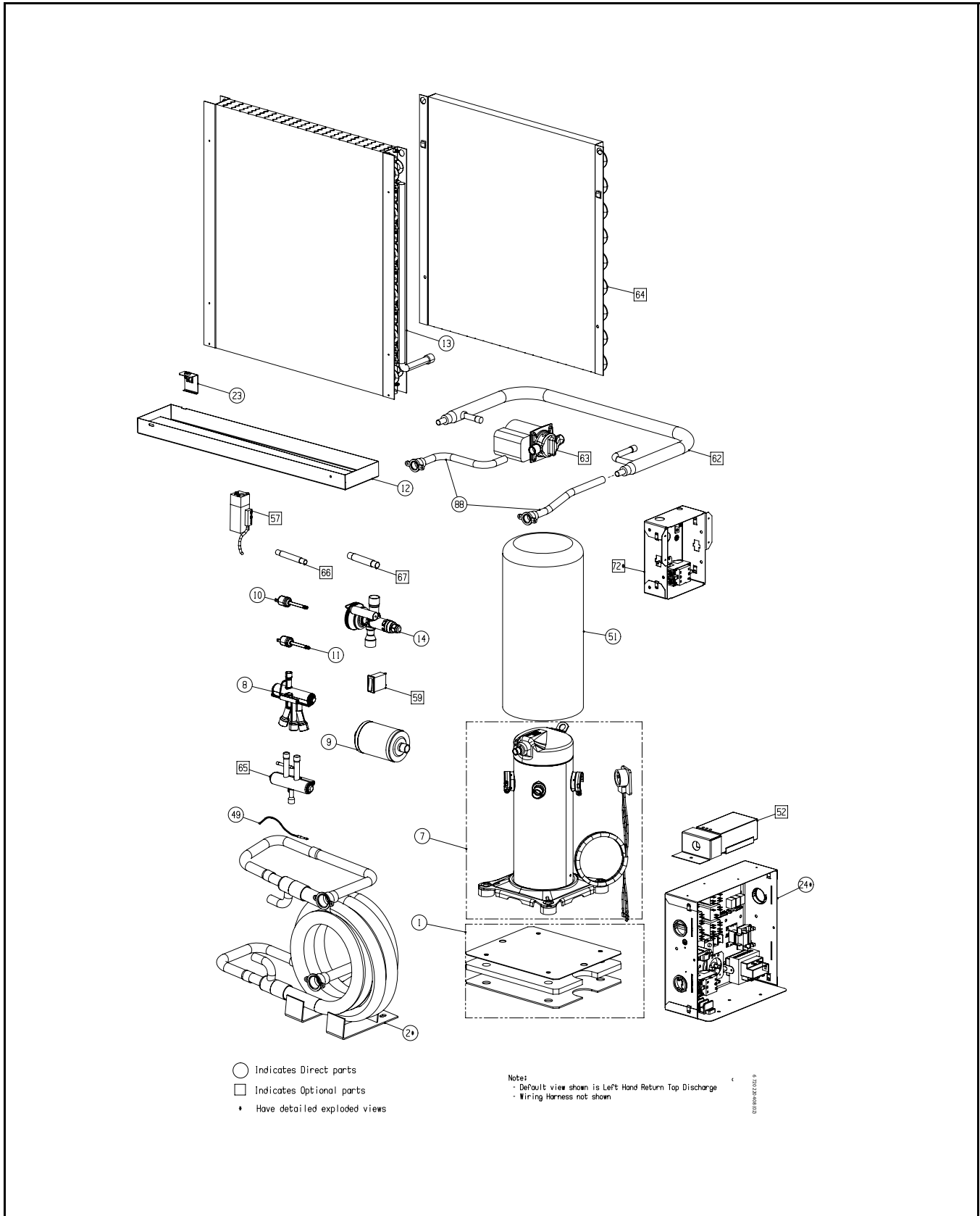

Figure # 127

VT Parts List - Detailed Views

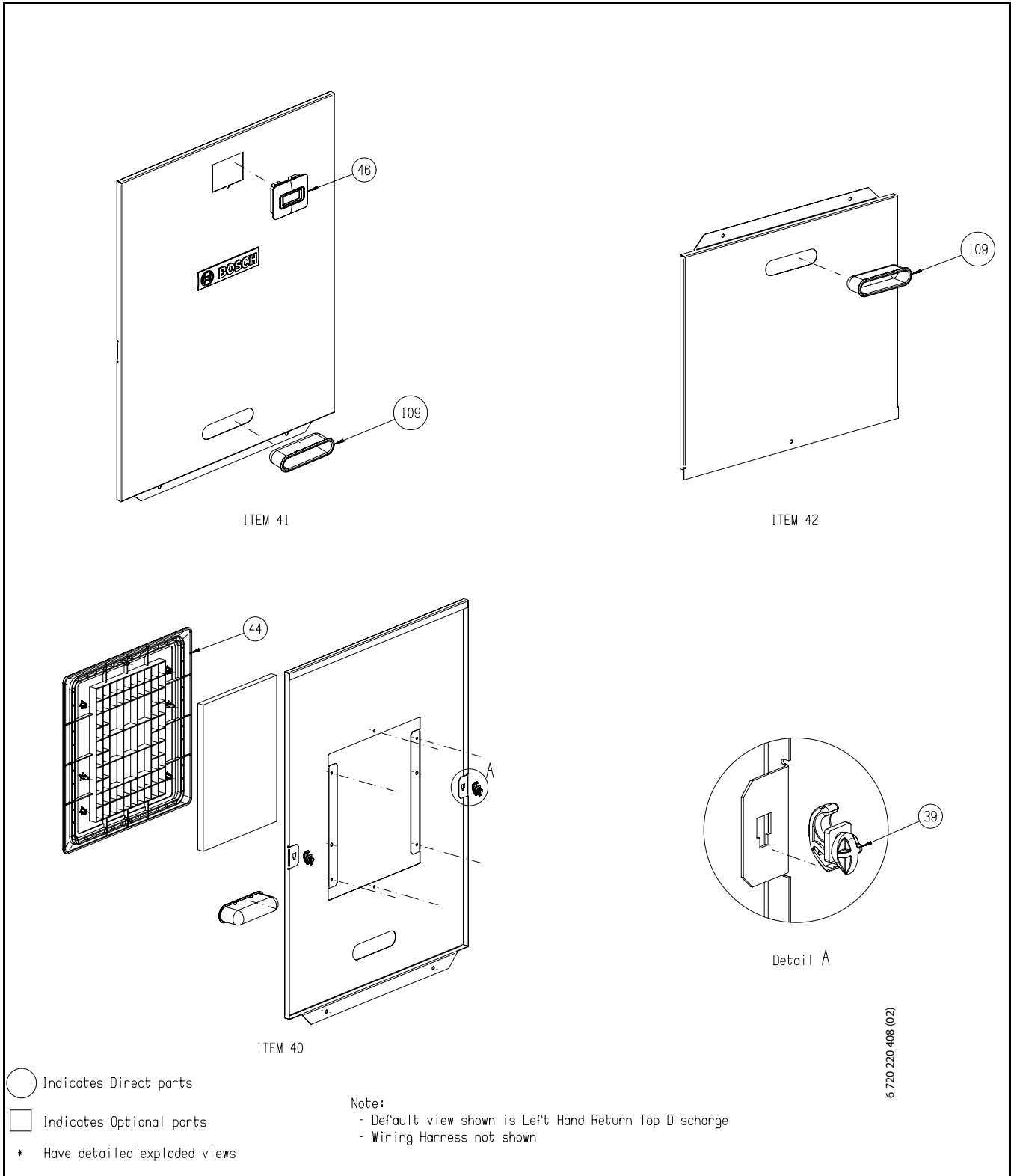

Figure # 128

VT Parts List - Detailed Views

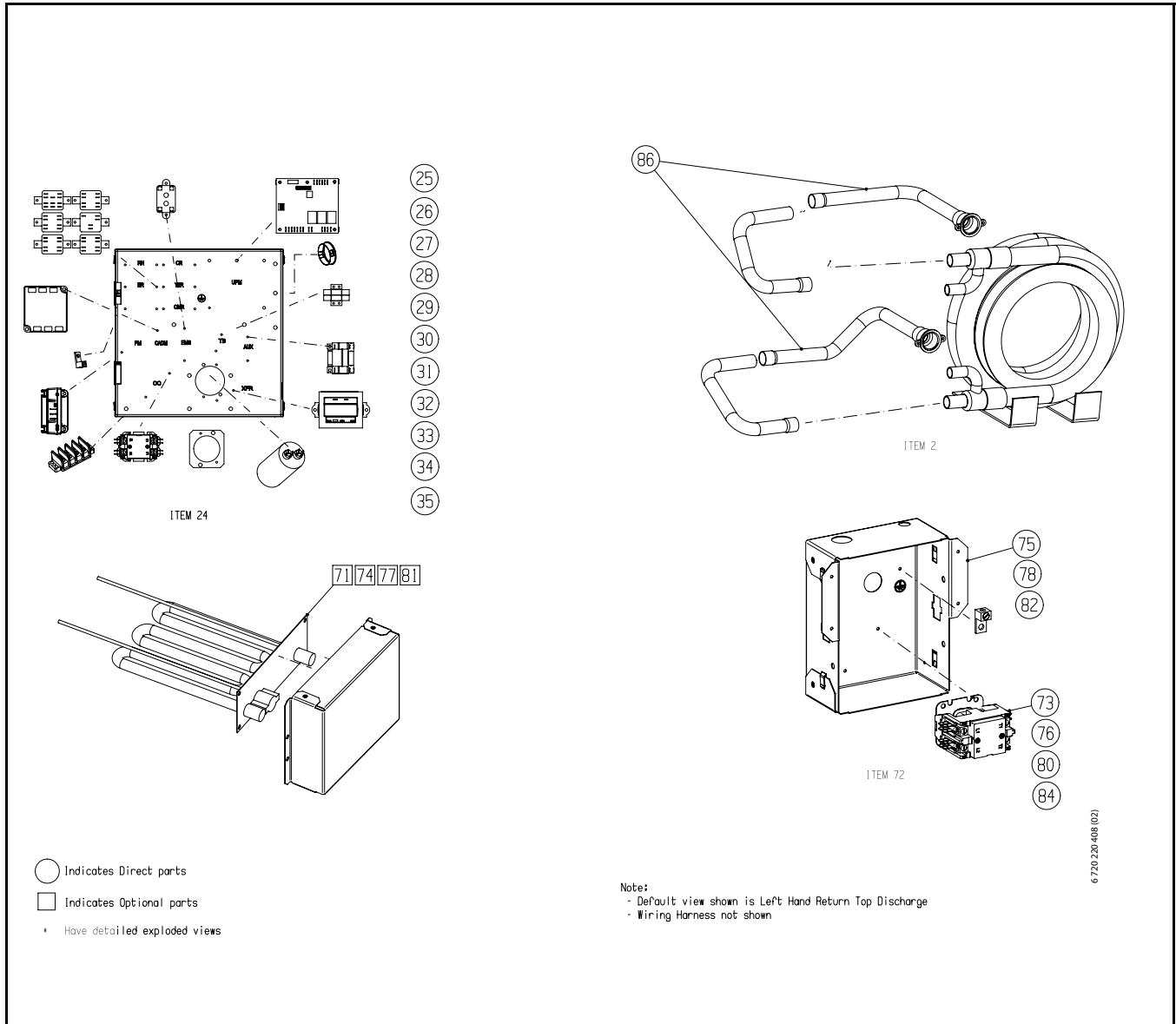

Figure # 129

Horizontal (HZ)

HORIZONTAL CONFIGURATION - PARTS LIST											
Item	Part / Desc	SM024-1HZC	SM024-1HZN	SM036-1HZC	SM036-1HZN	SM048-1HZC	SM048-1HZN	SM060-1HZC	SM060-1HZN	SM070-1HZC	SM070-1HZN
1	Floating Base Pan Kit	8733802642	8733802642	8733802642	8733802642	8733802642	8733802642	8733802642	8733802642	8733802642	8733802642
2	Water Coil Kit	8733802643	8733802719	8733802715	8733802720	8733802716	8733802721	8733802717	8733802722	8733802718	8733802723
7	Compressor Kit	8733802648	8733802648	8733802730	8733802730	8733802731	8733802731	8733802732	8733802732	8733802733	8733802733
8	Reversing Valve Kit	8733802649	8733802649	8733802734	8733802734	8733802735	8733802735	8733802735	8733802735	8733802735	8733802735
9	Filter Drier Kit	8733802650	8733802650	8733802650	8733802650	8733802650	8733802650	8733802650	8733802650	8733802650	8733802650
10	Lo Pressure Switch Kit	8733802651	8733802651	8733802651	8733802651	8733802651	8733802651	8733802651	8733802651	8733802651	8733802651
11	Hi Pressure Switch Kit	8733802652	8733802652	8733802652	8733802652	8733802652	8733802652	8733802652	8733802652	8733802652	8733802652
14	TXV Kit	8733802655	8733802655	8733802741	8733802741	8733802742	8733802742	8733802743	8733802743	8733802744	8733802744
16	Blower Kit	8733802657	8733802657	8733802745	8733802745	8733802745	8733802745	8733802746	8733802746	8733802746	8733802746
19	Constant Torque ECM Motor Kit	8733802660	8733802660	8733802749	8733802749	8733802750	8733802750	8733802751	8733802751	8733802752	8733802752
20	Motor Mounting Kit	8733802661	8733802661	8733802661	8733802661	8733802661	8733802661	8733802661	8733802661	8733802661	8733802661
21	Heater Collar Kit	8733802662	8733802662	8733802753	8733802753	8733802753	8733802753	8733802754	8733802754	8733802754	8733802754
23	Condensate Sensor Kit	8733802664	8733802664	8733802664	8733802664	8733802664	8733802664	8733802664	8733802664	8733802664	8733802664
24	* EBOX Kit	8733802665	8733802665	8733802756	8733802756	8733802757	8733802757	8733802758	8733802758	8733802758	8733802758
25	# Relay Kit	8733802666	8733802666	8733802666	8733802666	8733802666	8733802666	8733802666	8733802666	8733802666	8733802666
26	# Contactor Kit	8733802667	8733802667	8733802667	8733802667	8733802667	8733802667	8733802667	8733802667	8733802667	8733802667
27	# Capacitor Kit	8733802668	8733802668	8733802759	8733802759	8733802760	8733802760	8733802761	8733802761	8733802761	8733802761
28	# Transformer Kit	8733802669	8733802669	8733802669	8733802669	8733802669	8733802669	8733802669	8733802669	8733802669	8733802669
29	# UPM Kit	8733802670	8733802670	8733802670	8733802670	8733802670	8733802670	8733802670	8733802670	8733802670	8733802670
30	# Main Harness Kit	8733802671	8733802671	8733802671	8733802671	8733802671	8733802671	8733802671	8733802671	8733802671	8733802671
31	# Compressor Plug Kit - Hi voltage	8733802672	8733802672	8733802672	8733802672	8733802672	8733802672	8733802672	8733802672	8733802672	8733802672
34	# Transformer Harness Kit	8733802675	8733802675	8733802675	8733802675	8733802675	8733802675	8733802675	8733802675	8733802675	8733802675
35	# Condensator Interface Harness Kit	8733802676	8733802676	8733802676	8733802676	8733802676	8733802676	8733802676	8733802676	8733802676	8733802676
39	Clip Kit	8733802680	8733802680	8733802680	8733802680	8733802680	8733802680	8733802680	8733802680	8733802680	8733802680
44	Blower Cover Kit	8733802684	8733802684	8733802775	8733802775	8733802775	8733802775	8733802776	8733802776	8733802776	8733802776
46	Display Kit	8733802686	8733802686	8733802686	8733802686	8733802686	8733802686	8733802686	8733802686	8733802686	8733802686
48	Corner Cap Kit	8733802688	8733802688	8733802781	8733802781	8733802781	8733802781	8733802782	8733802782	8733802782	8733802782
49	Freeze sensor Kit	8733802689	8733802689	8733802689	8733802689	8733802689	8733802689	8733802783	8733802783	8733802783	8733802783
53	# Constant Airflow ECM Motor Kit	8733802693	8733802693	8733802784	8733802784	8733802785	8733802785	8733802786	8733802786	8733802787	8733802787
54	# Constant Airflow ECM Board Kit	8733802694	8733802694	8733802694	8733802694	8733802694	8733802694	8733802694	8733802694	8733802694	8733802694
57	DPS Switch Kit	8733802697	8733802697	8733802697	8733802697	8733802697	8733802697	8733802697	8733802697	8733802697	8733802697
58	# HRP Relay Kit	8733802698	8733802698	8733802698	8733802698	8733802698	8733802698	8733802698	8733802698	8733802698	8733802698
59	HRP Switch Kit	8733802699	8733802699	8733802699	8733802699	8733802699	8733802699	8733802699	8733802699	8733802699	8733802699
60	# HRP Water Temp Sensor Kit	8733802700	8733802700	8733802700	8733802700	8733802700	8733802700	8733802700	8733802700	8733802700	8733802700
62	HRP Coil Kit	8733802702	8733802702	8733802702	8733802702	8733802788	8733802788	8733802788	8733802788	8733802788	8733802788
63	HRP Pump Kit	8733802703	8733802703	8733802703	8733802703	8733802703	8733802703	8733802703	8733802703	8733802703	8733802703
65	Reheat Valve Kit	-	-	8733802705	8733802705	8733802705	8733802705	8733802705	8733802705	8733802705	8733802705
66	HGRH Small Check Valve Kit	-	-	8733802706	8733802706	8733802706	8733802706	8733802706	8733802706	8733802706	8733802706
67	HGRH Big Check Valve Kit	-	-	8733802707	8733802707	8733802707	8733802707	8733802707	8733802707	8733802707	8733802707
68	HGRH Top Panel Kit	-	-	8733802791	8733802791	8733802791	8733802791	8733802792	8733802792	8733802792	8733802792
69	# HGRH Main Harness Kit	-	-	8733802709	8733802709	8733802709	8733802709	8733802709	8733802709	8733802709	8733802709
70	# Comfort Alert Module Kit	8733802710	8733802710	8733802710	8733802710	8733802710	8733802710	8733802710	8733802710	8733802710	8733802710
71	# 5kW EH Element Kit	8733802711	8733802711	8733802711	8733802711	8733802711	8733802711	8733802711	8733802711	8733802711	8733802711
72	5kW EH Cntrl Box KIT	8733802712	8733802712	8733802712	8733802712	8733802712	8733802712	8733802712	8733802712	8733802712	8733802712
73	# 5kW EH Contactor Kit	8733802713	8733802713	8733802713	8733802713	8733802713	8733802713	8733802713	8733802713	8733802713	8733802713
74	# 10kW EH Element Kit	-	-	8733802793	8733802793	8733802793	8733802793	8733802793	8733802793	8733802793	8733802793

75	#	10kW EH Cntrl Box KIT	-	-	8733802794	8733802794	8733802794	8733802794	8733802794	8733802794	8733802794	8733802794
76	#	10kW EH Contactor Kit	-	-	8733802795	8733802795	8733802795	8733802795	8733802795	8733802795	8733802795	8733802795
77	#	15kW EH Element Kit	-	-	-	-	8733802796	8733802796	8733802796	8733802796	8733802796	8733802796
78	#	15kW EH Cntrl Box KIT	-	-	-	-	8733802797	8733802797	8733802797	8733802797	8733802797	8733802797
79	#	15kW EH Fuse Box Kit	-	-	-	-	8733802798	8733802798	8733802798	8733802798	8733802798	8733802798
80	#	15kW EH Contactor Kit	-	-	-	-	-	8733802799	8733802799	8733802799	8733802799	8733802799
81	#	20kW EH Element Kit	-	-	-	-	-	8733802800	8733802800	8733802800	8733802800	8733802800
82	#	20kW EH Cntrl Box KIT	-	-	-	-	-	8733802801	8733802801	8733802801	8733802801	8733802801
83	#	20kW EH Fuse Box Kit	-	-	-	-	-	8733802802	8733802802	8733802802	8733802802	8733802802
84	#	20kW EH Contactor Kit	-	-	-	-	-	8733802803	8733802803	8733802803	8733802803	8733802803
85		Drain Post RH Kit	8733904516	8733904516	8733904517	8733904517	8733904517	8733904517	8733904517	8733904517	8733904517	8733904517
86		EH Post RH Kit	8733904518	8733904518	8733904519	8733904519	8733904519	8733904519	8733904519	8733904519	8733904519	8733904519
87		Water Post RH Kit	8733904520	8733904520	8733904521	8733904521	8733904521	8733904521	8733904521	8733904521	8733904521	8733904521
88		Electrical Post RH Kit	8733904522	8733904522	8733904523	8733904523	8733904523	8733904523	8733904523	8733904523	8733904523	8733904523
89		Evap Assembly Kit	8733904524	8733904524	8733904525	8733904525	8733904526	8733904526	8733904527	8733904527	8733904528	8733904528
90		Drain Pan RH Kit	8733904529	8733904529	8733904530	8733904530	8733904530	8733904530	8733904531	8733904531	8733904531	8733904531
91		Top Panel Kit	8733904532	8733904532	8733904533	8733904533	8733904533	8733904533	8733904534	8733904534	8733904534	8733904534
92		Wide Center Post Kit	8733904535	8733904535	8733904536	8733904536	8733904536	8733904536	8733904536	8733904536	8733904536	8733904536
93		Narrow Center Post Kit	8733904537	8733904537	8733904538	8733904538	8733904538	8733904538	8733904538	8733904538	8733904538	8733904538
94		Logo Panel Kit	8733904539	8733904539	8733904540	8733904540	8733904540	8733904540	8733904540	8733904540	8733904540	8733904540
95		Compressor Panel Kit	8733904541	8733904541	8733904542	8733904542	8733904542	8733904542	8733904542	8733904542	8733904542	8733904542
96		Water Coil Panel Kit	8733904543	8733904543	8733904544	8733904544	8733904544	8733904544	8733904545	8733904545	8733904545	8733904545
97		Blower End Panel Kit	8733904546	8733904546	8733904547	8733904547	8733904547	8733904547	8733904548	8733904548	8733904548	8733904548
98		Blower Side Panel Kit	8733904549	8733904549	8733904550	8733904550	8733904550	8733904550	8733904551	8733904551	8733904551	8733904551
99		Filter rack Kit	8733904552	8733904552	8733904553	8733904553	8733904553	8733904553	8733904554	8733904554	8733904554	8733904554
100		Blower Harness Kit	8733904555	8733904555	8733904555	8733904555	8733904555	8733904555	8733904555	8733904555	8733904555	8733904555
101		Display Harness Kit	8733904556	8733904556	8733904556	8733904556	8733904556	8733904556	8733904556	8733904556	8733904556	8733904556
102		MERV11 Air Filter Kit	8733904557	8733904557	8733904557	8733904557	8733904557	8733904557	8733904557	8733904557	8733904557	8733904557
103		Blower Mounting Bracket Kit	8733904558	8733904558	8733904558	8733904558	8733904558	8733904558	8733904558	8733904558	8733904558	8733904558
104		Hot Gas Reheat Coil Kit	-	-	8733904560	8733904560	8733904560	8733904560	8733904570	8733904570	8733904570	8733904570
105	#	Constant Airflow ECM Control Harness Kit	8733904562	8733904562	8733904562	8733904562	8733904562	8733904562	8733904562	8733904562	8733904562	8733904562
107	#	Constant Airflow Blower Power Harness Kit	8733904563	8733904563	8733904563	8733904563	8733904563	8733904563	8733904563	8733904563	8733904563	8733904563
108	#	HGRH + ECM constant air flow Main Harness Kit	-	-	8733904564	8733904564	8733904564	8733904564	8733904564	8733904564	8733904564	8733904564
109		Handle Plastic Kit	8733803589	8733803589	8733803589	8733803589	8733803589	8733803589	8733803589	8733803589	8733803589	8733803589
110		Hanging Bracket kit	T111930008	T111930008	T111930008	T111930008	T111930008	T111930008	T111930008	T111930008	T111930008	T111930008

not shown in drawing

* Detailed view available

All refrigerant circuit components kit includes filter drier

HZ Part List - Cabinet

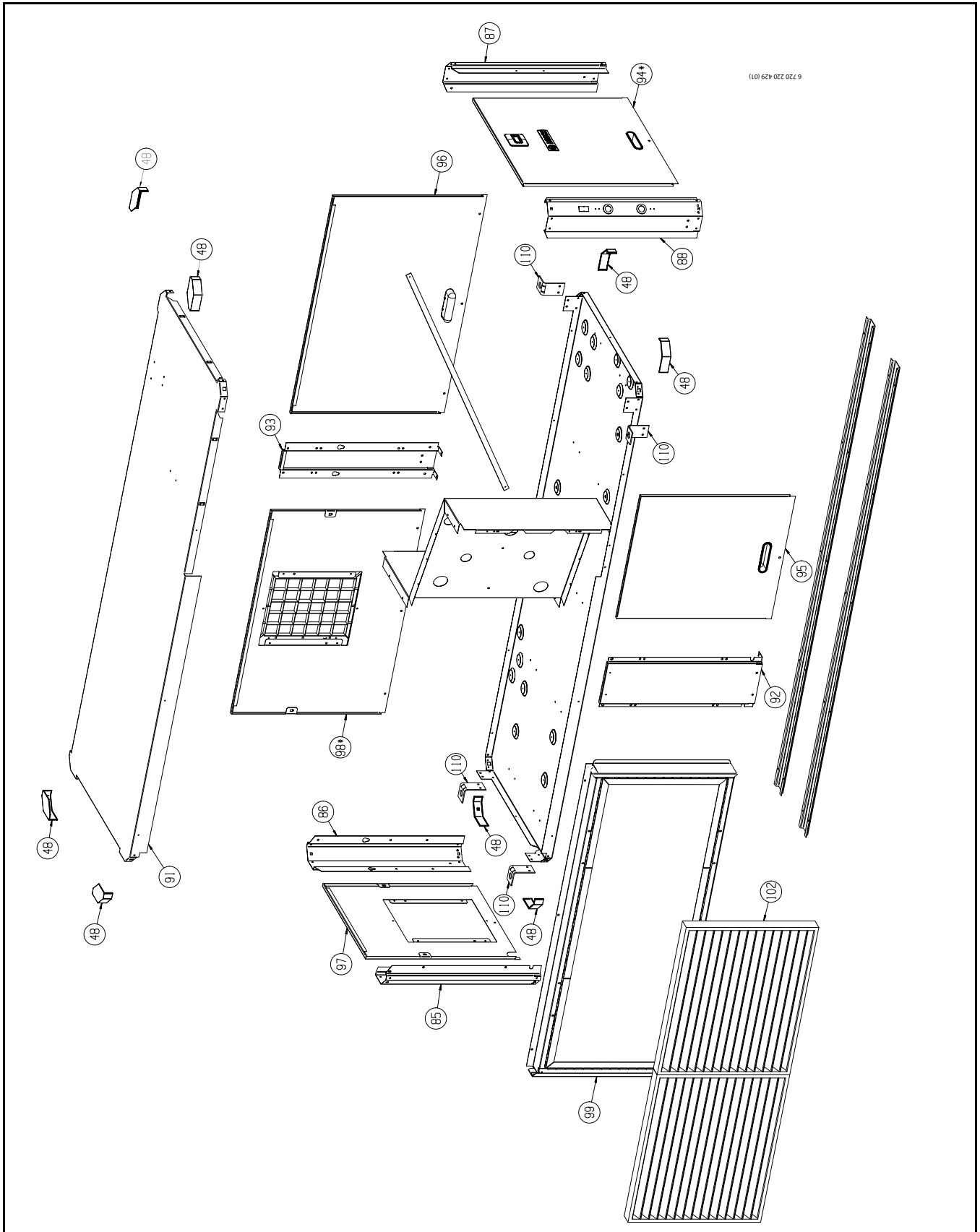

Figure # 130

HZ Parts List - Blower

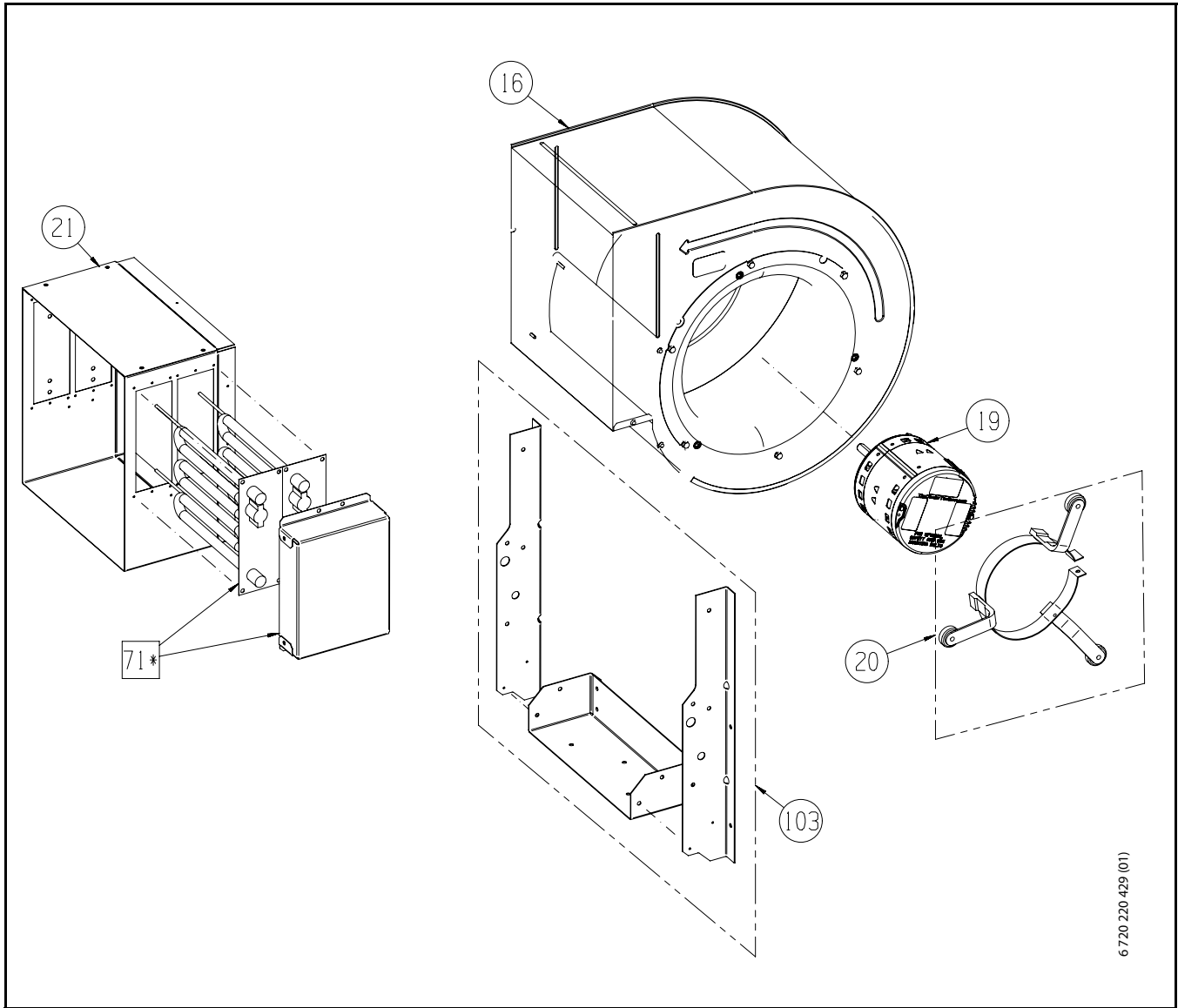

Figure # 131

6720 220 429 (01)

HZ Parts List - Refrigeration

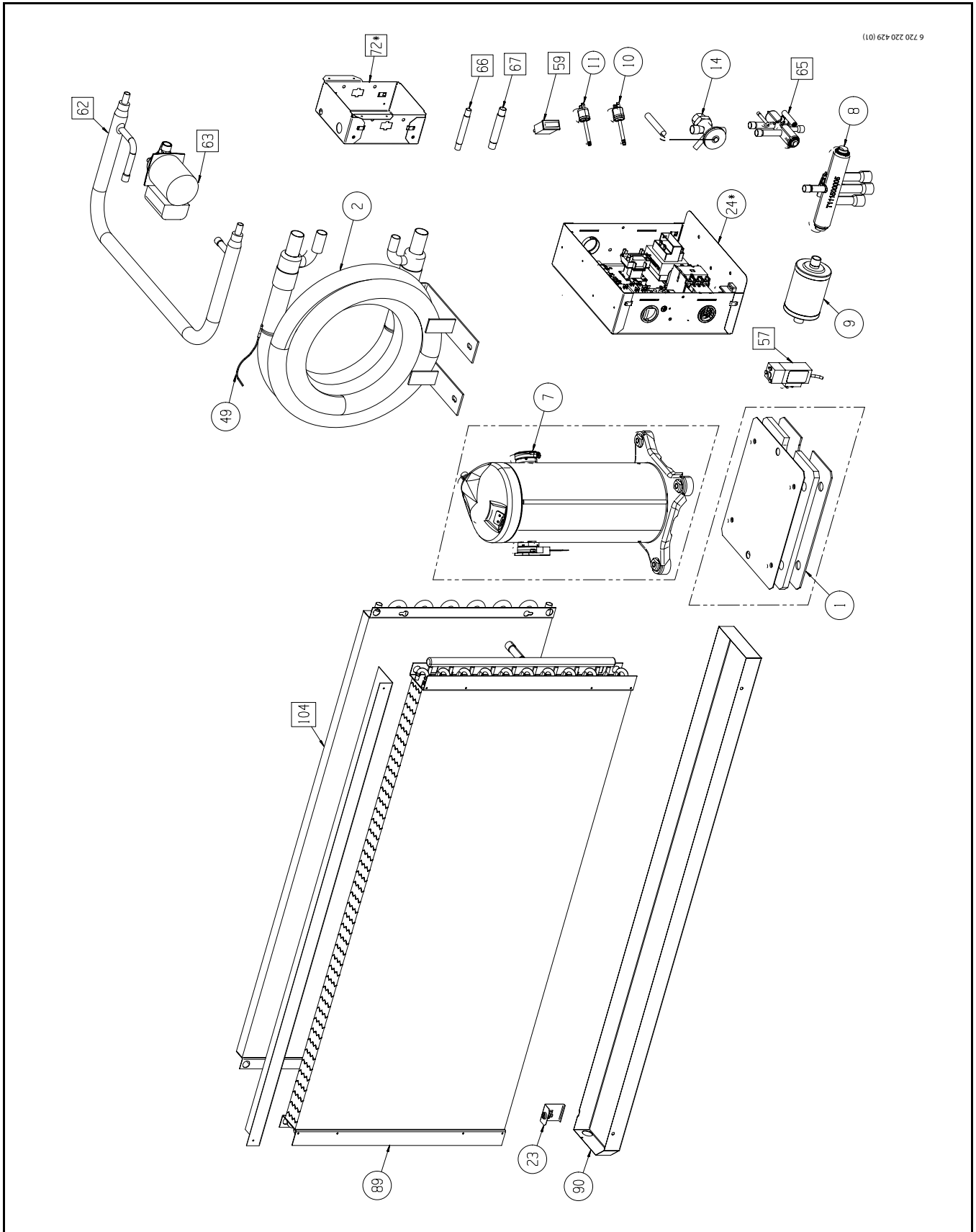
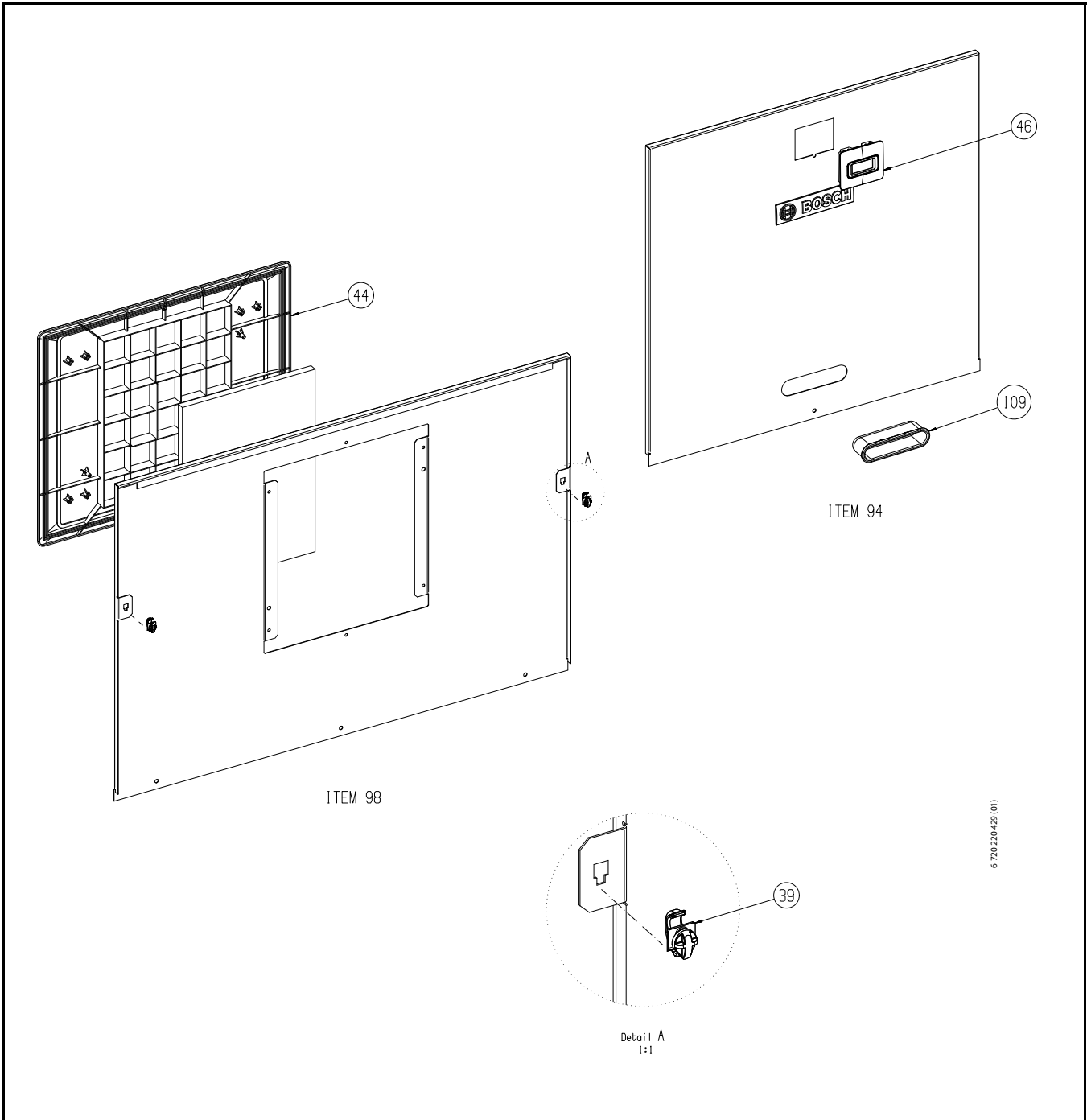

Figure # 132

HZ Part List - Panels



6 720 220 429 (01)

Figure # 133

HZ Part List - Detailed View

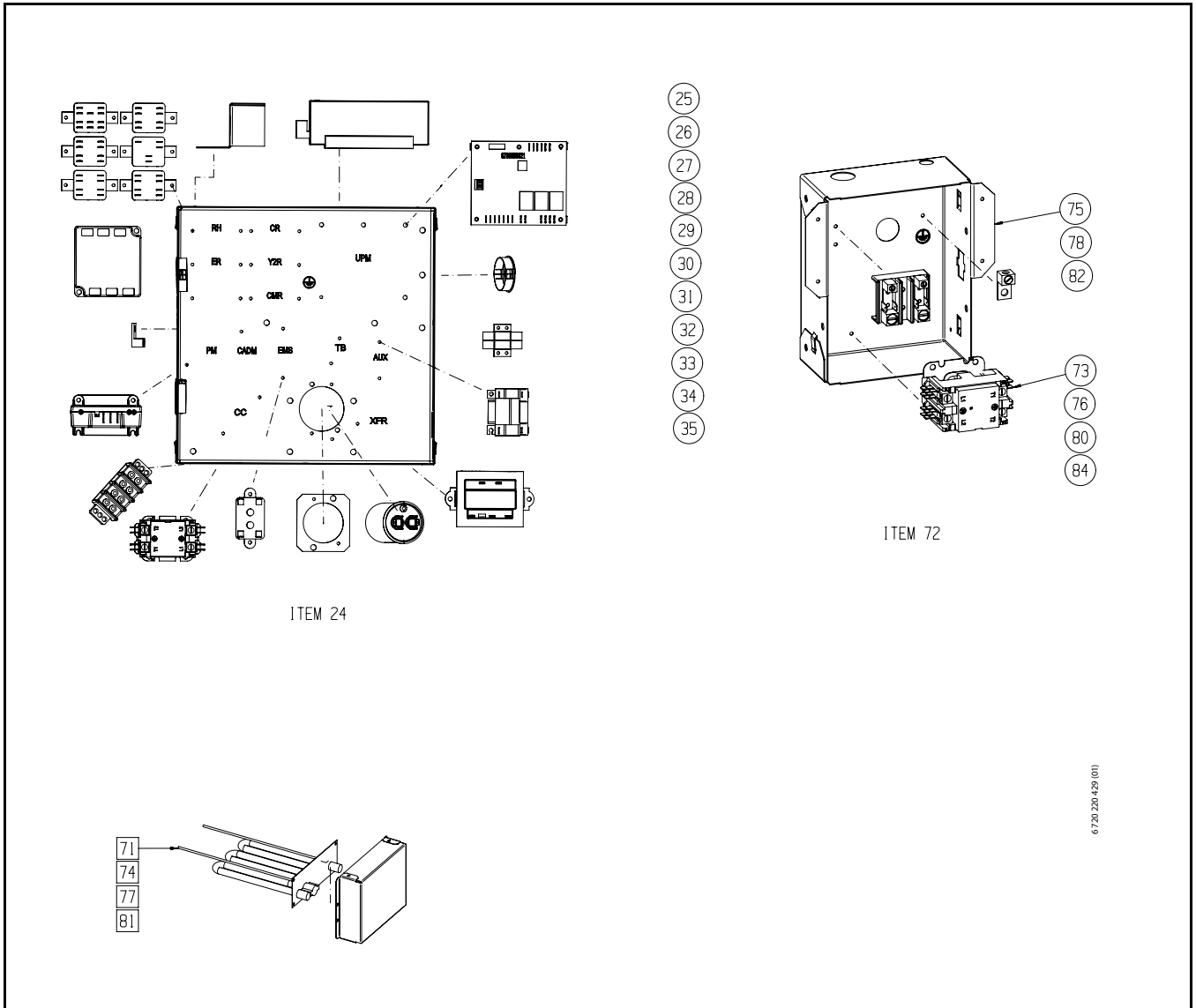

Figure # 134

Counter Flow Part List

COUNTER FLOW CONFIGURATION - PARTS LIST											
Item	Part / Desc	SM024-1CFC	SM024-1CFN	SM036-1CFC	SM036-1CFN	SM048-1CFC	SM048-1CFN	SM060-1CFC	SM060-1CFN	SM070-1CFC	SM070-1CFN
1	Floating Base Pan Kit	8733802642	8733802642	8733802642	8733802642	8733802642	8733802642	8733802642	8733802642	8733802642	8733802642
2	Water Coil Kit	8733802643	8733802719	8733802715	8733802720	8733802716	8733802721	8733802717	8733802722	8733802718	8733802723
6	Black Nylon Plug Kit	8733802647	8733802647	8733802647	8733802647	8733802647	8733802647	8733802647	8733802647	8733802647	8733802647
7	Compressor Kit	8733802648	8733802648	8733802730	8733802730	8733802731	8733802731	8733802732	8733802732	8733802733	8733802733
8	Reversing Valve Kit	8733802649	8733802649	8733802734	8733802734	8733802735	8733802735	8733802735	8733802735	8733802735	8733802735
9	Filter Drier Kit	8733802650	8733802650	8733802650	8733802650	8733802650	8733802650	8733802650	8733802650	8733802650	8733802650
10	Lo Pressure Switch Kit	8733802651	8733802651	8733802651	8733802651	8733802651	8733802651	8733802651	8733802651	8733802651	8733802651
11	Hi Pressure Switch Kit	8733802652	8733802652	8733802652	8733802652	8733802652	8733802652	8733802652	8733802652	8733802652	8733802652
13	Air Coil Kit	8733802654	8733802654	8733802737	8733802737	8733802738	8733802738	8733802844	8733802844	8733802740	8733802740
14	TXV Kit	8733802655	8733802655	8733802741	8733802741	8733802742	8733802742	8733802743	8733802743	8733802744	8733802744
15	Reinforcing Bracket Kit	8733802656	8733802656	8733802656	8733802656	8733802656	8733802656	8733802656	8733802656	8733802656	8733802656
16	Blower Kit	8733802657	8733802657	8733802745	8733802745	8733802745	8733802745	8733802746	8733802746	8733802746	8733802746
17	HZ Blower mounting Bracket Kit	8733802658	8733802658	8733802658	8733802658	8733802658	8733802658	8733802747	8733802747	8733802747	8733802747
18	Vert. Blower Mounting Bracket KIT	8733802659	8733802659	8733802748	8733802748	8733802748	8733802748	8733802748	8733802748	8733802748	8733802748
19	Constant Torque ECM Motor Kit	8733802660	8733802660	8733802749	8733802749	8733802750	8733802750	8733802751	8733802751	8733802752	8733802752
20	Motor Mounting Kit	8733802661	8733802661	8733802661	8733802661	8733802661	8733802661	8733802661	8733802661	8733802661	8733802661
21	Heater Collar Kit	8733802662	8733802662	8733802753	8733802753	8733802753	8733802753	8733802754	8733802754	8733802754	8733802754
22	# Condensate Drain Kit	8733802663	8733802663	8733802663	8733802663	8733802663	8733802663	8733802663	8733802663	8733802663	8733802663
23	Condensate Sensor Kit	8733802664	8733802664	8733802664	8733802664	8733802664	8733802664	8733802664	8733802664	8733802664	8733802664
24	* EBOX Kit	8733802665	8733802665	8733802756	8733802756	8733802757	8733802757	8733802758	8733802758	8733802758	8733802758
25	# Relay Kit	8733802666	8733802666	8733802666	8733802666	8733802666	8733802666	8733802666	8733802666	8733802666	8733802666
26	# Contactor Kit	8733802667	8733802667	8733802667	8733802667	8733802667	8733802667	8733802667	8733802667	8733802667	8733802667
27	# Capacitor Kit	8733802668	8733802668	8733802759	8733802759	8733802760	8733802760	8733802761	8733802761	8733802761	8733802761
28	# Transformer Kit	8733802669	8733802669	8733802669	8733802669	8733802669	8733802669	8733802669	8733802669	8733802669	8733802669
29	# UPM Kit	8733802670	8733802670	8733802670	8733802670	8733802670	8733802670	8733802670	8733802670	8733802670	8733802670
30	# Main Harness Kit	8733802671	8733802671	8733802671	8733802671	8733802671	8733802671	8733802671	8733802671	8733802671	8733802671
31	# Compressor Plug Kit - Hi voltage	8733802672	8733802672	8733802672	8733802672	8733802672	8733802672	8733802672	8733802672	8733802672	8733802672
32	# Blower Harness Kit	8733802673	8733802673	8733802673	8733802673	8733802673	8733802673	8733802673	8733802673	8733802673	8733802673
33	# Display Harness Kit	8733802674	8733802674	8733802674	8733802674	8733802674	8733802674	8733802674	8733802674	8733802674	8733802674
34	# Transformer Harness Kit	8733802675	8733802675	8733802675	8733802675	8733802675	8733802675	8733802675	8733802675	8733802675	8733802675
35	# Condensor Interface Harness Kit	8733802676	8733802676	8733802676	8733802676	8733802676	8733802676	8733802676	8733802676	8733802676	8733802676
37	Belt Panel Kit	8733802678	8733802678	8733802764	8733802764	8733802764	8733802764	8733802765	8733802765	8733802765	8733802765
39	Clip Kit	8733802680	8733802680	8733802680	8733802680	8733802680	8733802680	8733802680	8733802680	8733802680	8733802680
45	Filter Rack Assy Kit	8733802685	8733802685	8733802777	8733802777	8733802777	8733802777	8733802778	8733802778	8733802778	8733802778
46	Display Kit	8733802686	8733802686	8733802686	8733802686	8733802686	8733802686	8733802686	8733802686	8733802686	8733802686
47	MERV-11 Filter Kit	8733802687	8733802687	8733802779	8733802779	8733802779	8733802779	8733802780	8733802780	8733802780	8733802780
48	Corner Cap Kit	8733802688	8733802688	8733802781	8733802781	8733802781	8733802781	8733802782	8733802782	8733802782	8733802782
49	Freeze sensor Kit	8733802689	8733802689	8733802689	8733802689	8733802689	8733802689	8733802783	8733802783	8733802783	8733802783
53	# Constant Airflow ECM Motor Kit	8733802693	8733802693	8733802784	8733802784	8733802785	8733802785	8733802786	8733802786	8733802787	8733802787
54	# Constant Airflow ECM Board Kit	8733802694	8733802694	8733802694	8733802694	8733802694	8733802694	8733802694	8733802694	8733802694	8733802694
55	# Constant Airflow ECM Harness Kit	8733802562	8733802562	8733802562	8733802562	8733802562	8733802562	8733802562	8733802562	8733802562	8733802562
57	DPS Switch Kit	8733802697	8733802697	8733802697	8733802697	8733802697	8733802697	8733802697	8733802697	8733802697	8733802697
58	# HRP Relay Kit	8733802698	8733802698	8733802698	8733802698	8733802698	8733802698	8733802698	8733802698	8733802698	8733802698
59	HRP Switch Kit	8733802699	8733802699	8733802699	8733802699	8733802699	8733802699	8733802699	8733802699	8733802699	8733802699
60	# HRP Water Temp Sensor Kit	8733802700	8733802700	8733802700	8733802700	8733802700	8733802700	8733802700	8733802700	8733802700	8733802700

62	HRP Coil Kit	8733802702	8733802702	8733802702	8733802702	8733802788	8733802788	8733802788	8733802788	8733802788	8733802788
63	HRP Pump Kit	8733802703	8733802703	8733802703	8733802703	8733802703	8733802703	8733802703	8733802703	8733802703	8733802703
64	HGRH Coil Kit	8733802704	8733802704	8733802789	8733802789	8733802789	8733802789	8733802790	8733802790	8733802790	8733802790
65	Reheat Valve Kit	-	-	8733802705	8733802705	8733802705	8733802705	8733802705	8733802705	8733802705	8733802705
66	HGRH Small Check Valve Kit	-	-	8733802706	8733802706	8733802706	8733802706	8733802706	8733802706	8733802706	8733802706
67	HGRH Big Check Valve Kit	-	-	8733802707	8733802707	8733802707	8733802707	8733802707	8733802707	8733802707	8733802707
68	HGRH Top Panel Kit	-	-	8733802791	8733802791	8733802791	8733802791	8733802792	8733802792	8733802792	8733802792
69	# HGRH Main Harness Kit	-	-	8733802709	8733802709	8733802709	8733802709	8733802709	8733802709	8733802709	8733802709
70	# Comfort Alert Module Kit	8733802710	8733802710	8733802710	8733802710	8733802710	8733802710	8733802710	8733802710	8733802710	8733802710
71	# 5kW EH Element Kit	8733802711	8733802711	8733802711	8733802711	8733802711	8733802711	8733802711	8733802711	8733802711	8733802711
72	5kW EH Cntrl Box KIT	8733802712	8733802712	8733802712	8733802712	8733802712	8733802712	8733802712	8733802712	8733802712	8733802712
73	# 5kW EH Contactor Kit	8733802713	8733802713	8733802713	8733802713	8733802713	8733802713	8733802713	8733802713	8733802713	8733802713
74	# 10kW EH Element Kit	-	-	8733802793	8733802793	8733802793	8733802793	8733802793	8733802793	8733802793	8733802793
75	# 10kW EH Cntrl Box KIT	-	-	8733802794	8733802794	8733802794	8733802794	8733802794	8733802794	8733802794	8733802794
76	# 10kW EH Contactor Kit	-	-	8733802795	8733802795	8733802795	8733802795	8733802795	8733802795	8733802795	8733802795
77	# 15kW EH Element Kit	-	-	-	-	8733802796	8733802796	8733802796	8733802796	8733802796	8733802796
78	# 15kW EH Cntrl Box KIT	-	-	-	-	8733802797	8733802797	8733802797	8733802797	8733802797	8733802797
79	# 15kW EH Fuse Box Kit	-	-	-	-	8733802798	8733802798	8733802798	8733802798	8733802798	8733802798
80	# 15kW EH Contactor Kit	-	-	-	-	-	-	8733802799	8733802799	8733802799	8733802799
81	# 20kW EH Element Kit	-	-	-	-	-	-	8733802800	8733802800	8733802800	8733802800
82	# 20kW EH Cntrl Box KIT	-	-	-	-	-	-	8733802801	8733802801	8733802801	8733802801
83	# 20kW EH Fuse Box Kit	-	-	-	-	-	-	8733802802	8733802802	8733802802	8733802802
84	# 20kW EH Contactor Kit	-	-	-	-	-	-	8733802803	8733802803	8733802803	8733802803
85	# HGRH + ECM constant air flow Harness Kit	-	-	8733802714	8733802714	8733802714	8733802714	8733802714	8733802714	8733802714	8733802714
86	Water Piping Kit	8733803577	8733803577	8733803578	8733803578	8733803579	8733803579	8733803585	8733803585	8733803586	8733803586
87	Rubber Bushing kit	8733803587	8733803587	8733803587	8733803587	8733803587	8733803587	8733803587	8733803587	8733803587	8733803587
88	Vertical Post Small Kit	8733904481	8733904481	8733904482	8733904482	8733904482	8733904482	8733904483	8733904483	8733904483	8733904483
89	Vertical Post Wide LH Kit	8733904484	8733904484	8733904485	8733904485	8733904485	8733904485	8733904486	8733904486	8733904486	8733904486
90	Vertical Post Wide RH Kit	8733904487	8733904487	8733904488	8733904488	8733904488	8733904488	8733904489	8733904489	8733904489	8733904489
91	LH Drain Pan Kit	8733904490	8733904490	8733904491	8733904491	8733904492	8733904492	8733904492	8733904492	8733904492	8733904492
92	Top Panel Kit	8733904493	8733904493	8733904494	8733904494	8733904494	8733904494	8733904495	8733904495	8733904495	8733904495
93	Upper Panel Blank Kit	8733904496	8733904496	8733904497	8733904497	8733904497	8733904497	8733904498	8733904498	8733904498	8733904498
94	Upper Panel Evap Kit	8733904499	8733904499	8733904500	8733904500	8733904500	8733904500	8733904501	8733904501	8733904501	8733904501
95	* Upper Panel Logo Kit	8733904502	8733904502	8733904503	8733904503	8733904503	8733904503	8733904504	8733904504	8733904504	8733904504
96	* Lower Panel Blank Kit	8733904505	8733904505	8733904506	8733904506	8733904506	8733904506	8733904507	8733904507	8733904507	8733904507
97	* Lower Panel Drain LH Kit	8733904508	8733904508	8733904509	8733904509	8733904509	8733904509	8733904510	8733904510	8733904510	8733904510
98	HRP water pipe kit	8733804632	8733804632	8733804633	8733804633	8733804633	8733804633	8733804634	8733804634	8733804634	8733804634
99	RH Drain Pan Kit	8733804637	8733804637	8733804638	8733804638	8733804639	8733804639	8733804639	8733804639	8733804639	8733804639
107	# Constant Airflow Blower Power Harness Kit	8733904563	8733904563	8733904563	8733904563	8733904563	8733904563	8733904563	8733904563	8733904563	8733904563
109	Handle Plastic Kit	8733803589	8733803589	8733803589	8733803589	8733803589	8733803589	8733803589	8733803589	8733803589	8733803589

not shown in drawing
 * Detailed view available
 All refrigerant circuit components kit includes filter drier

Counter Flow Part List - Cabinet

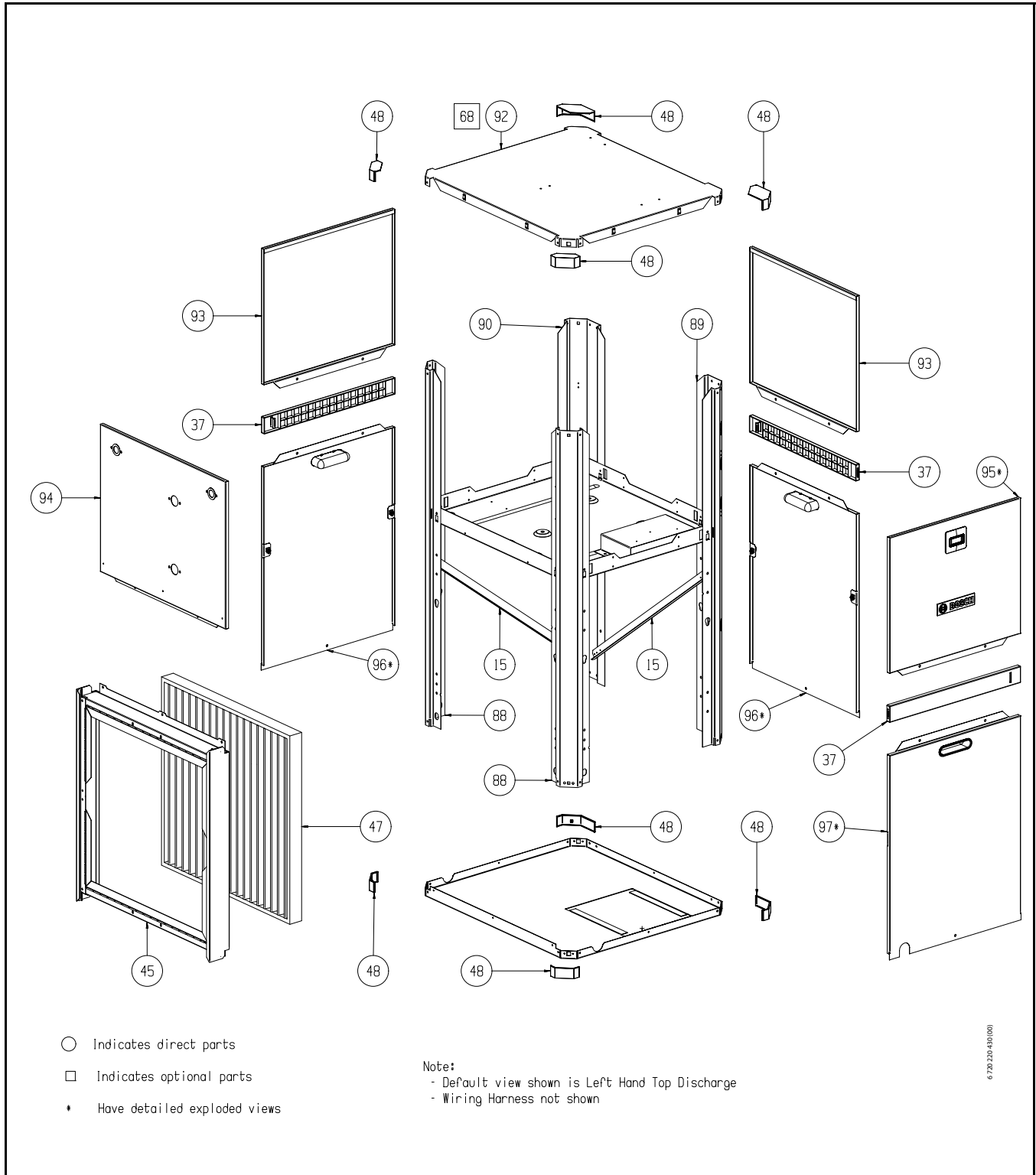

Figure # 135

Counter Flow Part List - Blower

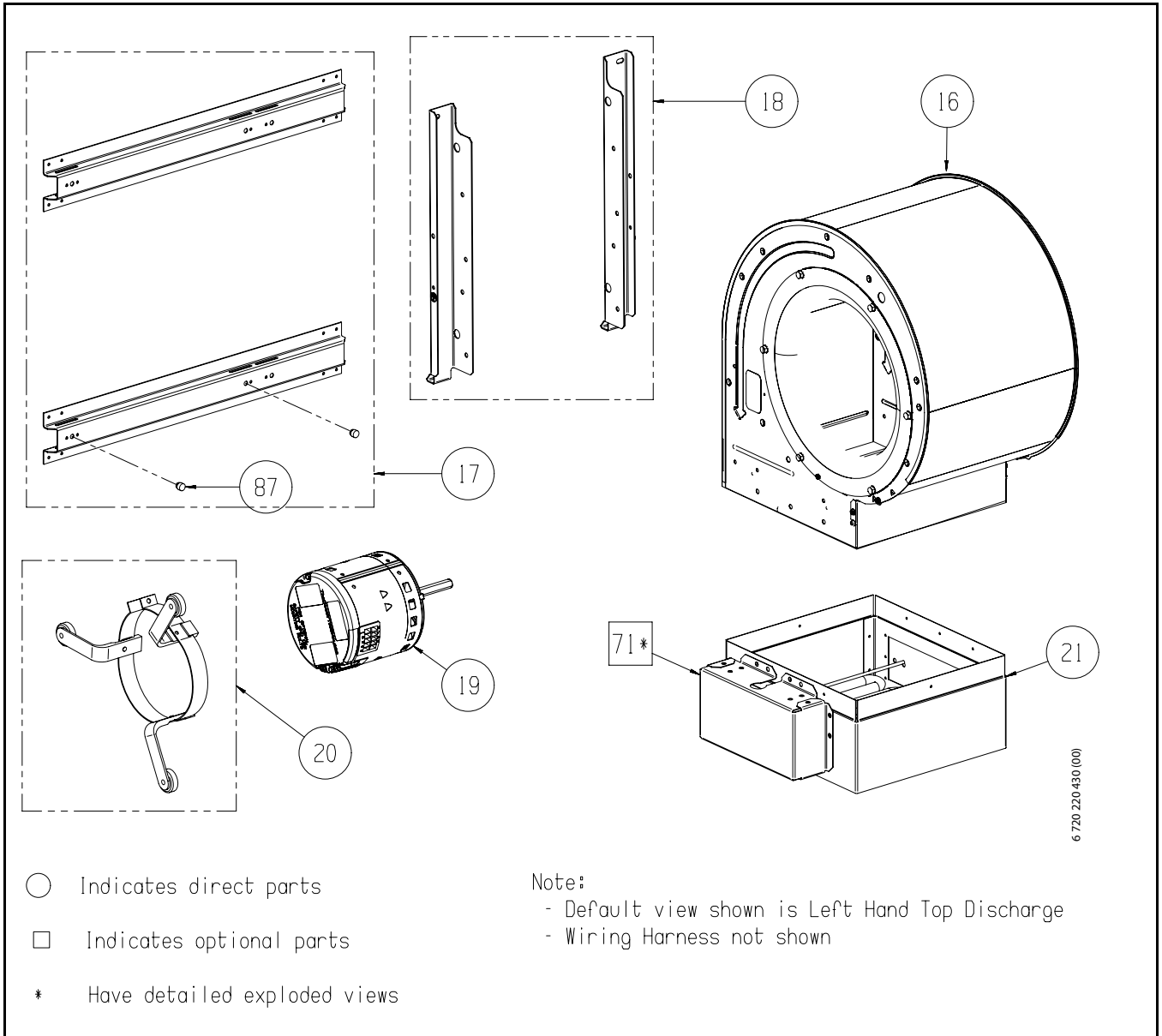

Figure # 136

Counter Flow Part List - Panels

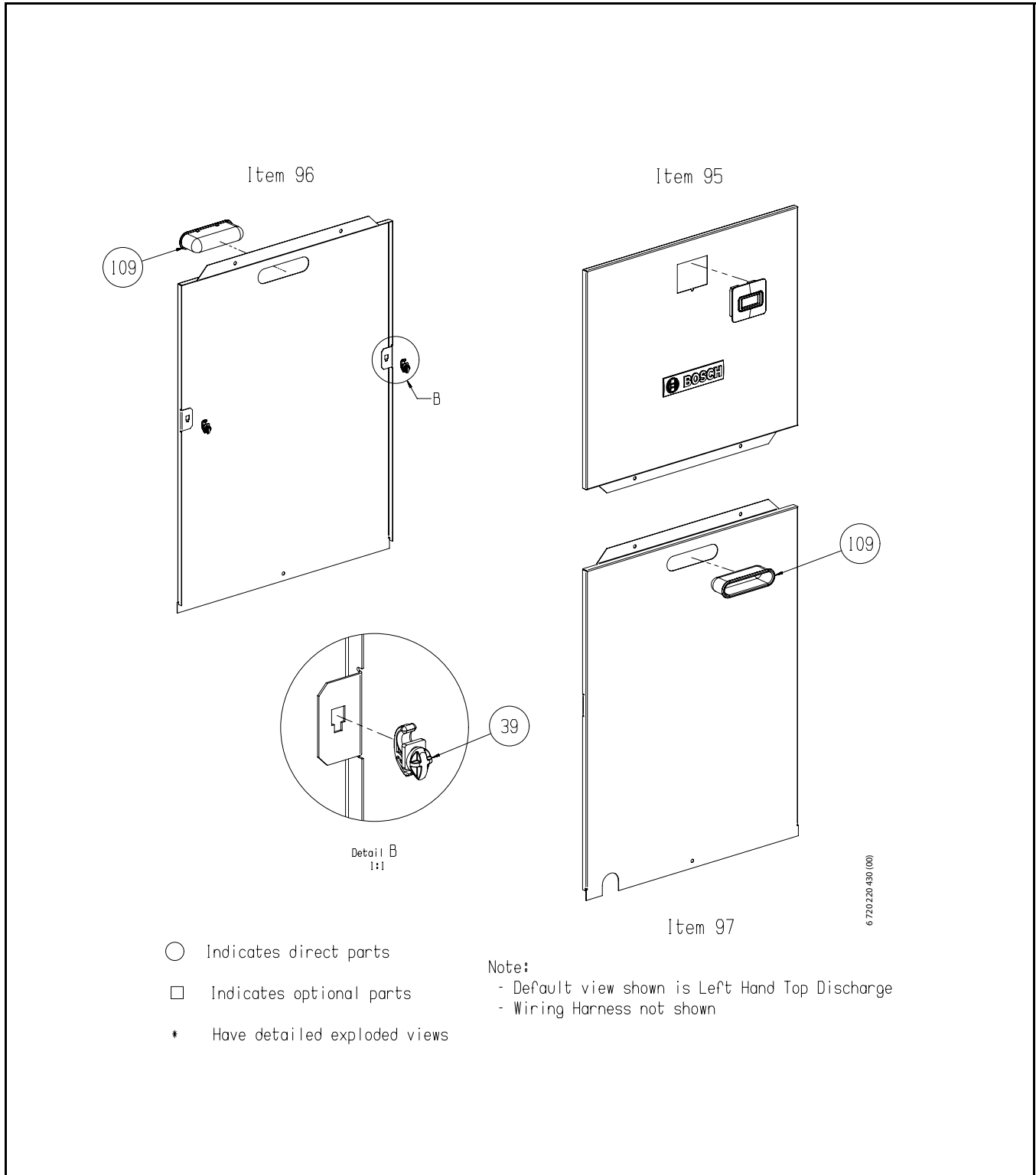

Figure # 137

Counter Flow Part List - Refrigeration

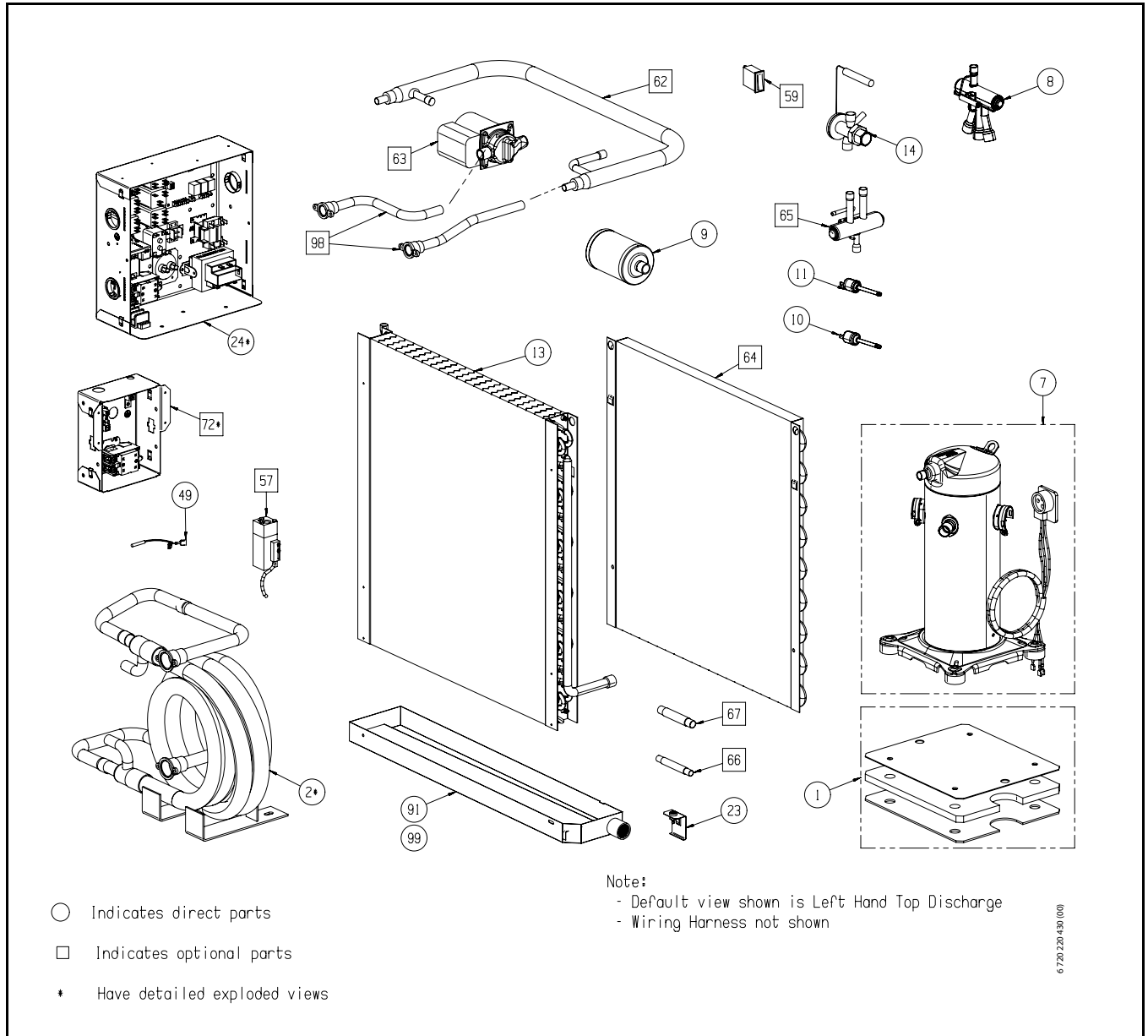

Figure # 138

Counter Flow Part List - Detailed View

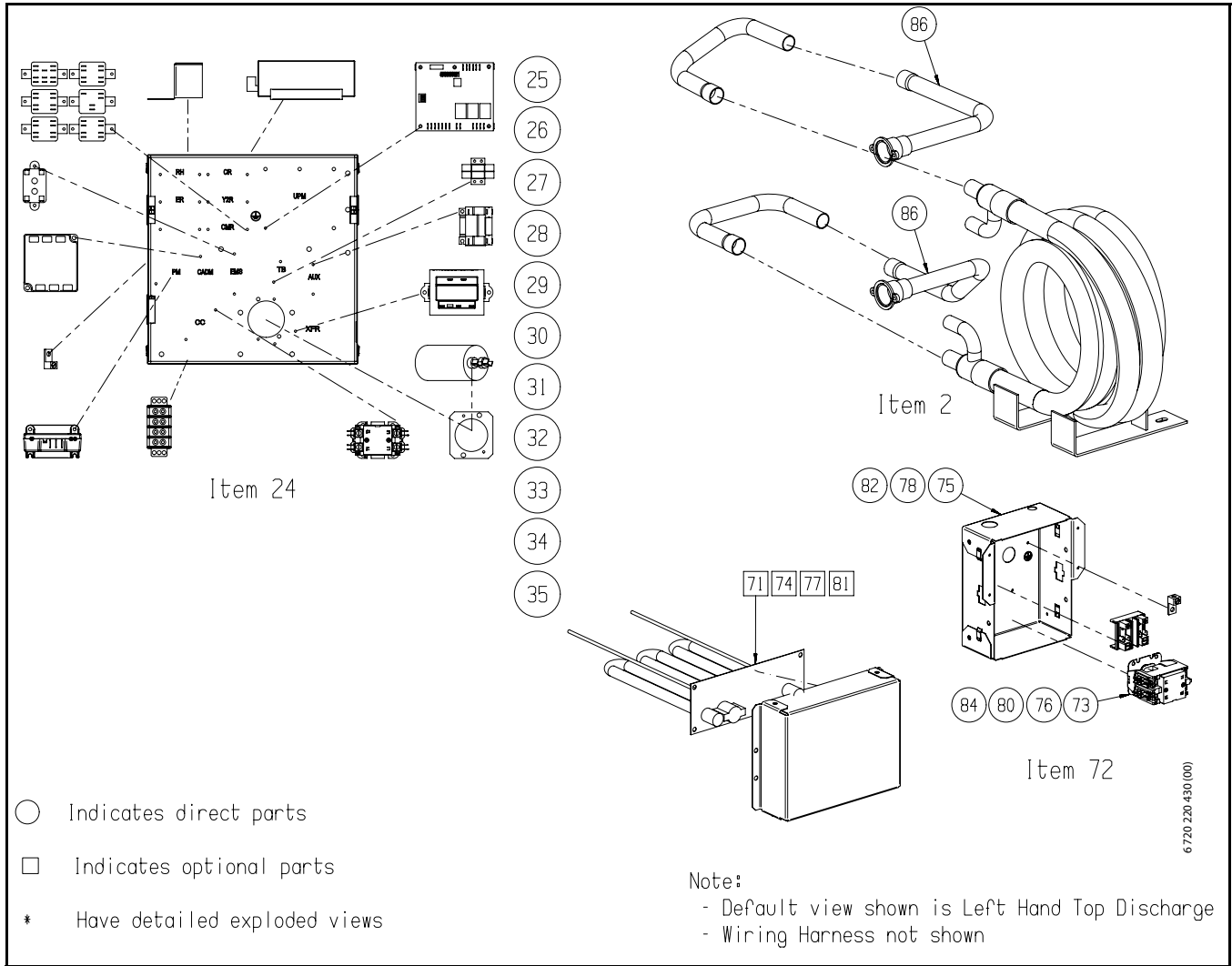

Figure # 139

DIMENSIONAL DRAWINGS

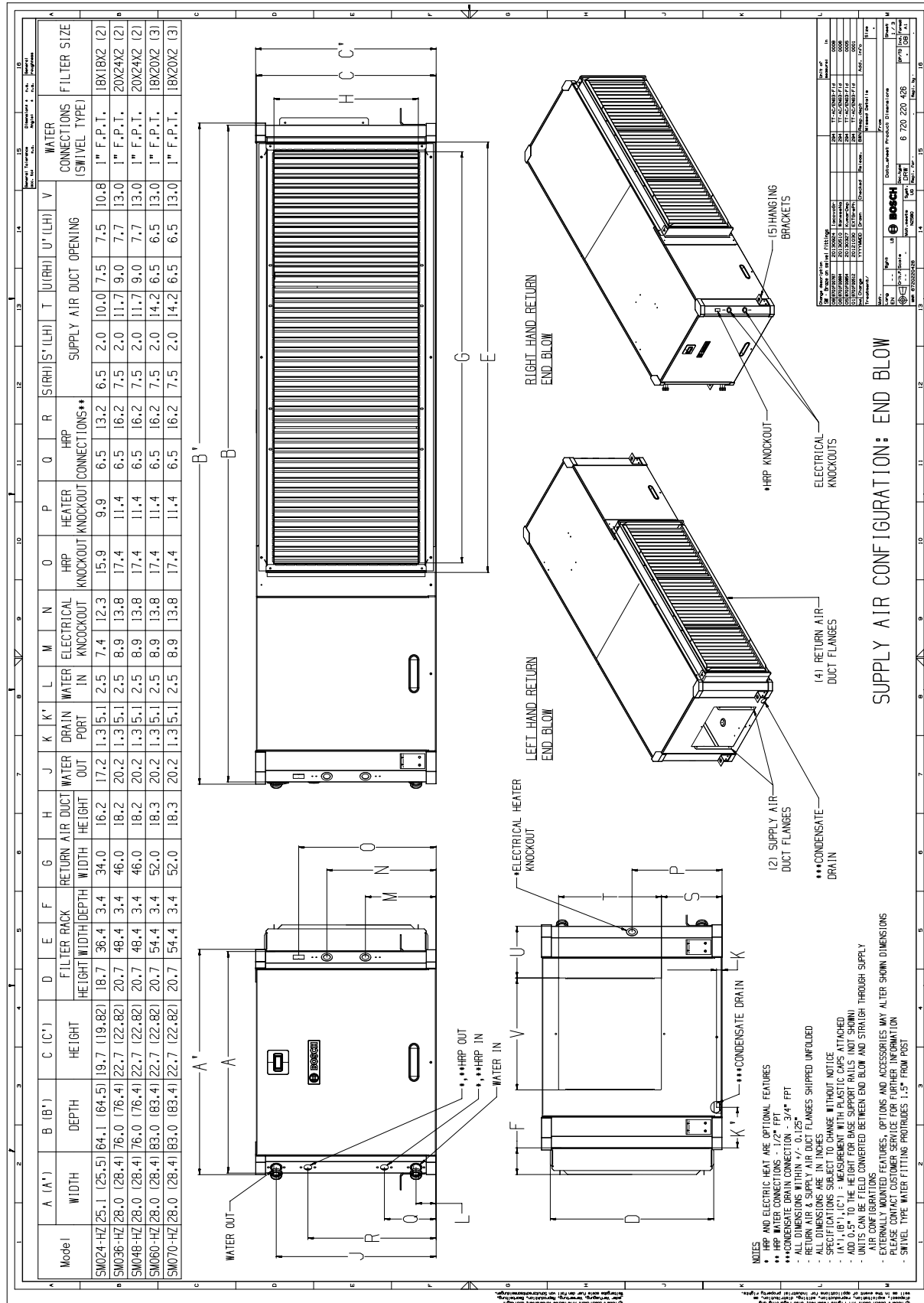

Figure # 140

Horizontal - Straight Through

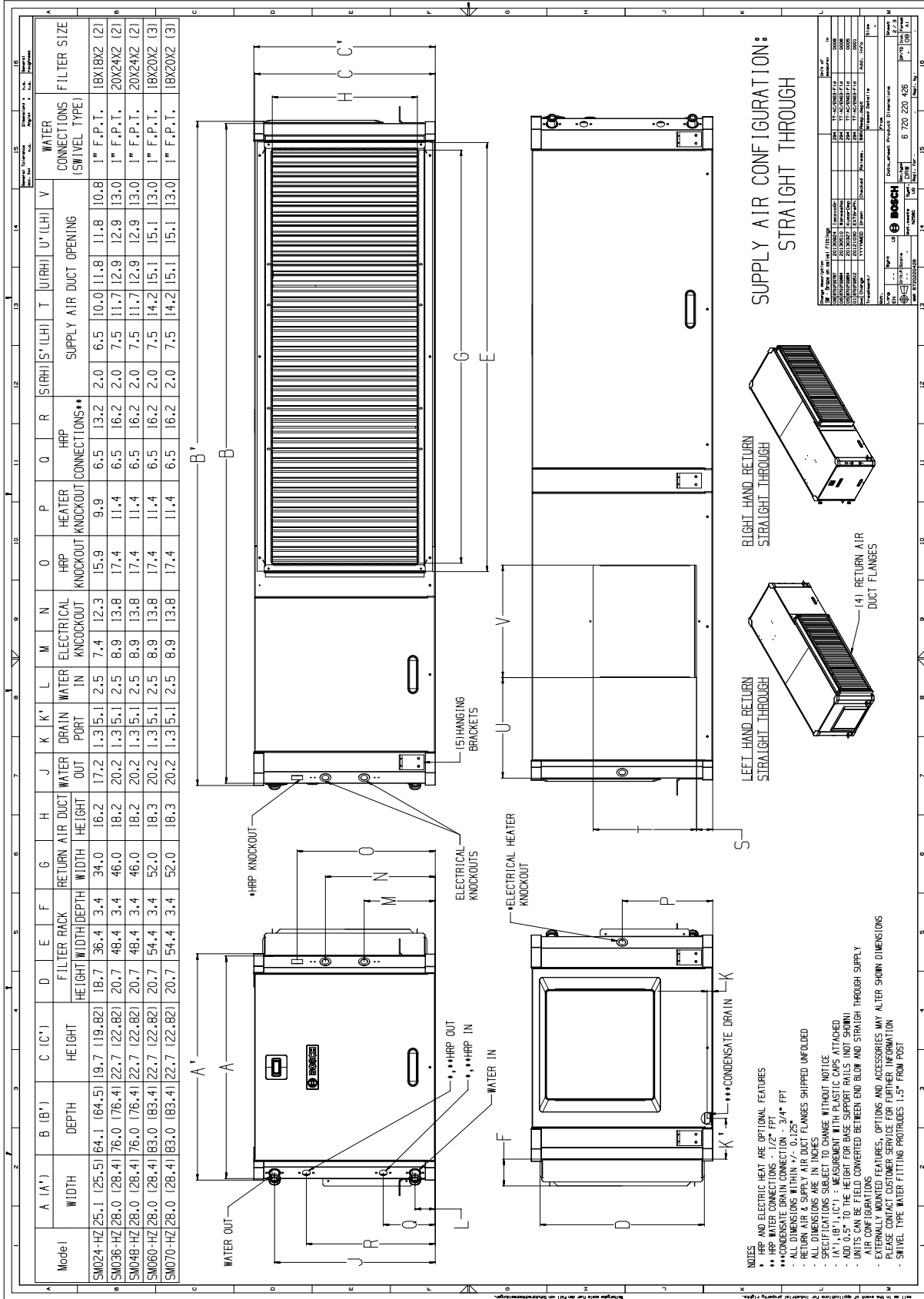
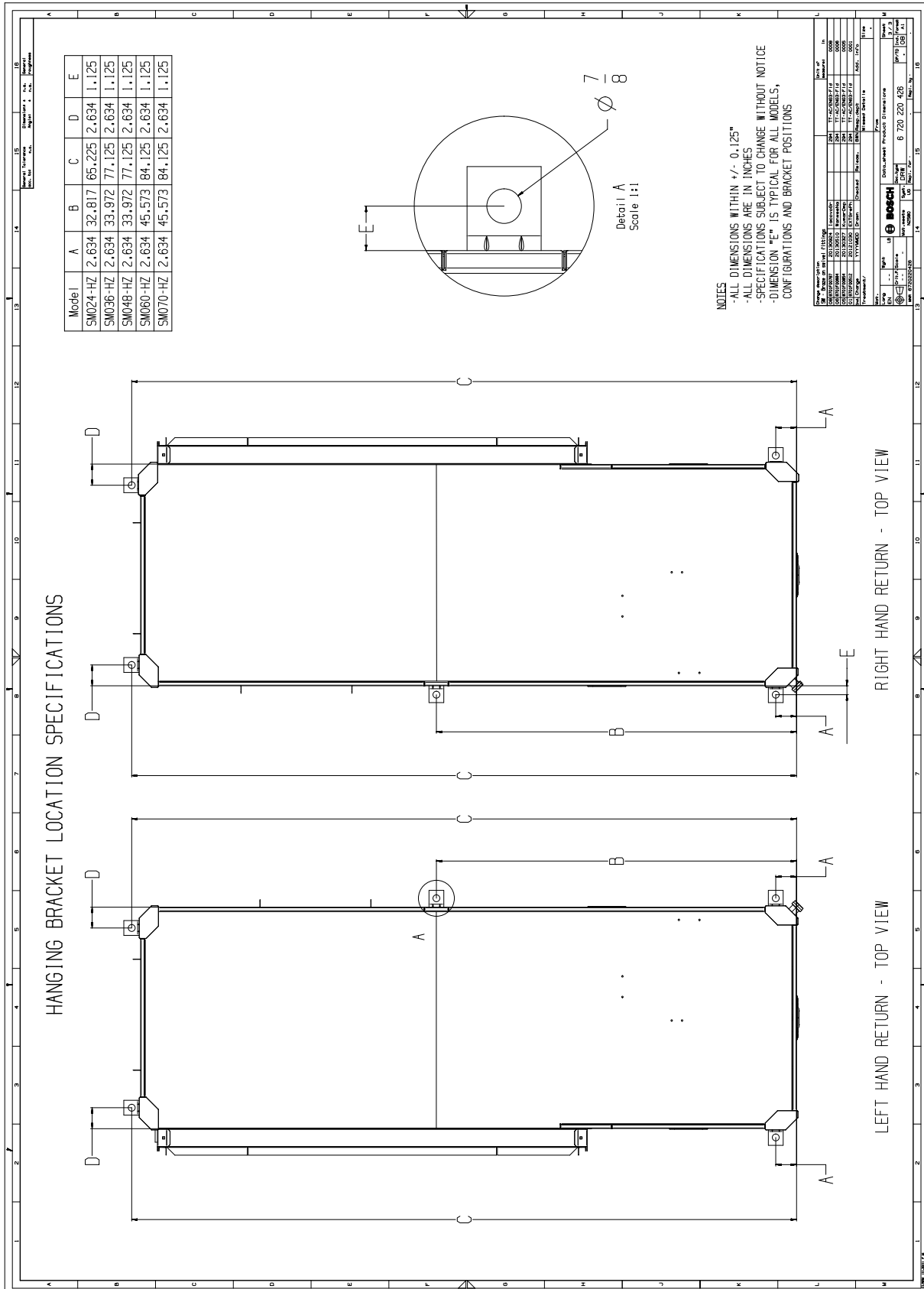

Figure # 141

Horizontal - Hanging bracket location



COUNTER FLOW

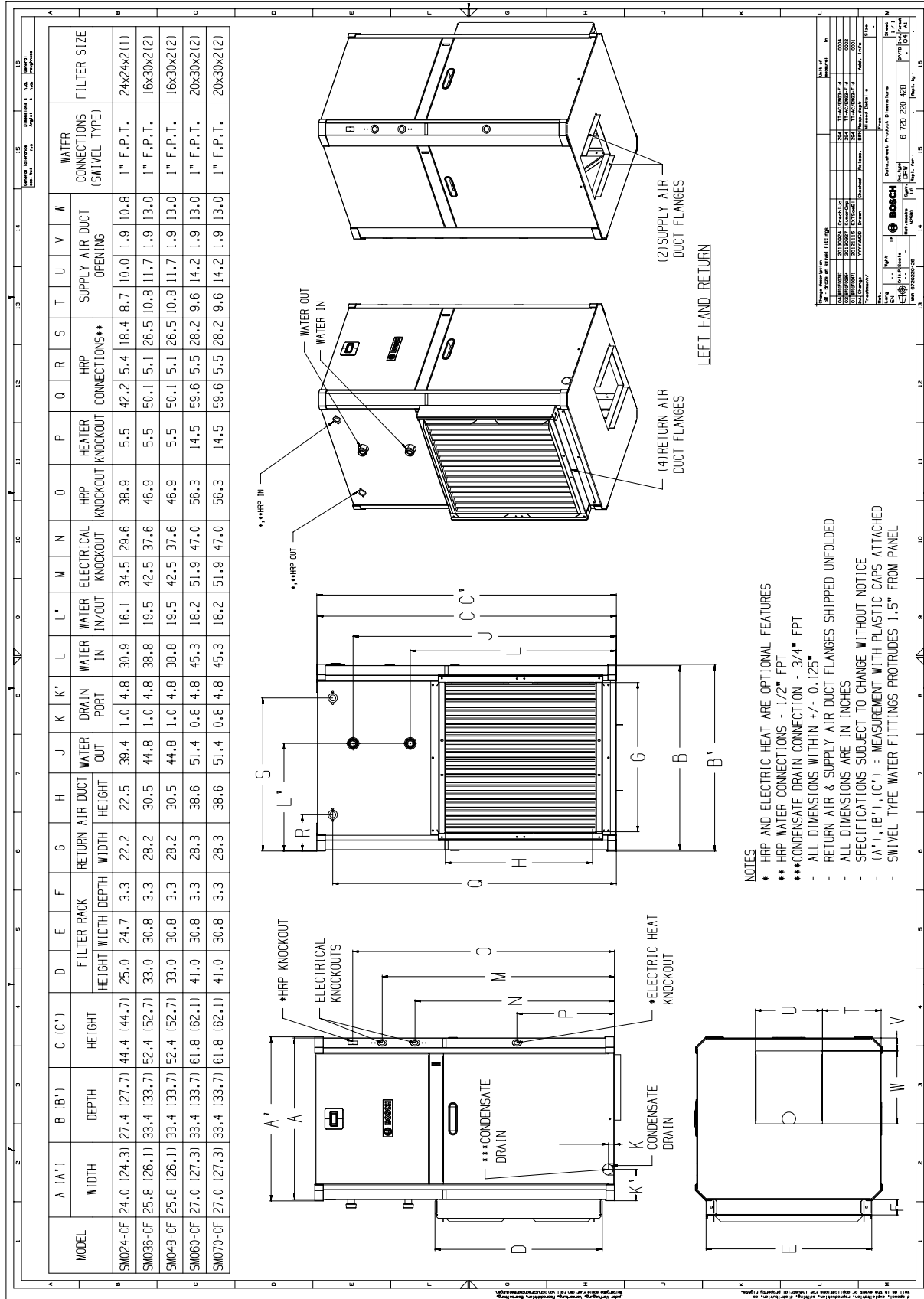

Figure # 143



BOSCH

555 N.W. 65th Court, Ft. Lauderdale, FL 33309
Phone: 866-642-3198 | Fax: 954-776-5529
www.bosch-climate.us
Revised 02/15

