

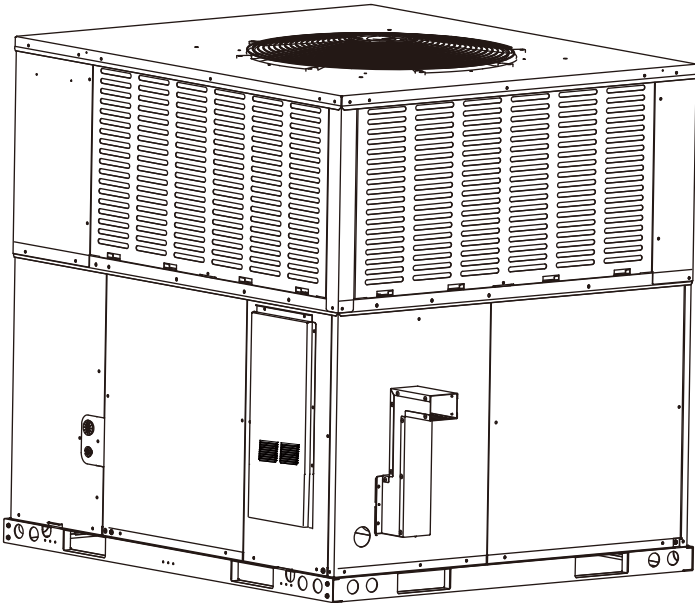

# INSTALLATION INSTRUCTIONS

PACKAGE GAS ELECTRIC UNITS  
FEATURING R-410A  
13.4 SEER2 SERIES - (2-5Tons)



Thank you very much for purchasing our product,  
Before using your unit , please read this manual carefully and keep it for future reference.  
The figure shown in this manual is for reference only and may be slightly different from the actual product.



CONFORMS TO UL  
STD. 60335-1 & UL  
STD. 60335-2-40 &  
ANSI STD. Z21.47  
CERTIFIED TO CSA  
STD. C22.2 No.  
60335-1 & CSA STD.  
C22.2 No. 60335-2-40  
& CSA STD. CSA 2.3



## RECOGNIZE THIS SYMBOL AS AN INDICATION OF IMPORTANT SAFETY INFORMATION

### WARNING

#### **FIRE OR EXPLOSION HAZARD**

Failure to follow safety warnings exactly could result in serious injury death or property damage.

### WARNING

Do not store or use gasoline or other flammable vapors and liquids, or other combustible materials in the vicinity of this or any other appliance.

#### **WHAT TO DO IF YOU SMELL GAS**

- Do not try to light any appliance; do not touch any electrical switch; do not use any phone in your building.
- Immediately call your gas supplier from a neighbor's phone. Follow the gas supplier's instructions.
- If you cannot reach your gas supplier, call the fire department.
- Do not return to your home until authorized by the gas supplier or fire department.

Improper installation, adjustment, alteration, service or maintenance can cause property damage, personal injury or death. Refer to this manual, installation and service must be performed by a qualified installer, service agency or the gas supplier. In the commonwealth of Massachusetts, installation must be performed by a licensed plumber or gas fitter for appropriate fuel.

### NOTE

Do not use this furnace if any part has been under water. A flood-damaged furnace is extremely dangerous. Attempts to use the furnace can result in fire or explosion. A qualified service agency should be contacted to inspect the furnace and to replace all gas controls, control system parts, electrical parts that have been wet or the furnace if deemed necessary.

This appliance is not intended for use by persons (including children) with reduced physical, sensory or mental capabilities, or lack of experience and knowledge, unless they have been given supervision or instruction concerning use of the appliance by a person responsible for their safety.

Children should be supervised to ensure that they do not play with the appliance.

# CONTENTS

## 1 SAFETY

- 1.1 Inspection..... 04
- 1.2 Limitations..... 04

## 2 INTRODUCTION ..... 05

## 3 INSTALLATION

- 3.1 Pre-installation Check-points..... 11
- 3.2 Location Considerations..... 11
- 3.3 Outside Installation..... 11
- 3.4 Attaching Exhaust and Combustion Air Inlet Hoods..... 11
- 3.5 Cover Panel Installation / Conversion Procedure..... 12
- 3.6 Clearance..... 13
- 3.7 Rigging and Handling..... 13

• 3.8	Roof Curb.....	15
• 3.9	Ductwork.....	16
• 3.10	Return Air.....	16
• 3.11	Filters.....	16
<b>4 GAS SUPPLY, CONDENSATE DRAIN AND PIPING</b>		
• 4.1	Gas Connection.....	16
• 4.2	Conversion.....	17
• 4.3	Adjusting or Checking Furnace Input.....	18
• 4.4	Condensate Drain.....	18
<b>5 WIRING</b>		
• 5.1	Power Supply.....	18
• 5.2	Hook-up.....	19
• 5.3	Internal Wiring.....	19
• 5.4	Thermostat.....	19
<b>6 FURNACE SECTION CONTROLS AND IGNITION SYSTEM</b>		
• 6.1	Normal Furnace Operating Sequence.....	19
• 6.2	Operating Instructions.....	20
• 6.3	To Start the Furnace.....	20
• 6.4	To Shut Down Furnace.....	20
• 6.5	Burners.....	20
• 6.6	Manual Reset Overtemperature Control.....	20
• 6.7	Pressure Switch.....	21
• 6.8	Limit Control.....	21
<b>7 SYSTEM OPERATING INFORMATION</b>		
• 7.1	Advise the Customer.....	21
• 7.2	Furnace Section Maintenance.....	21
• 7.3	Lubrication.....	22
• 7.4	Cooling Section Maintenance.....	22
• 7.5	Replacement Parts.....	23
• 7.6	Wiring Diagrams.....	23
• 7.7	Charging.....	23
• 7.8	Blower Motor Speed Taps.....	23
<b>8 OPERATION</b>		
• 8.1	Control System Operation.....	23
• 8.2	Fan Delay Adjustment.....	23
<b>9 PHYSICAL DATA.....</b>		25
<b>10 AIRFLOW PERFORMANCE.....</b>		27
<b>11 TROUBLE SHOOTING.....</b>		30

This document is customer property and is to remain with this unit.

These instructions do not cover all the different variations of systems nor does it provide for every possible contingency to be met in connection with installation.

All phases of this installation must comply with NATION, STATE AND LOCAL CODES. If additional information is required please contact your local distributor.

## 1 SAFETY

When you see the symbols below on labels or in the manual, be alert to the potential or immediate hazards of personal injury, property and/or product damage. It is the owner's or installer's responsibility to comply with all safety instructions and information accompanying these symbols.



**WARNING:** This is a safety alert symbol indicating a potential hazardous situation, which could result in personal injury, property and/or product damage or death.



**CAUTION:** This is a safety alert symbol indicating a potential hazardous situation, which could result in moderate personal injury, and/or property and product damage.

### WARNING

These instructions are intended as an aid to qualified, licensed service personnel for proper installation, adjustment and operation of this unit. Read these instructions thoroughly before attempting installation or operation. Failure to follow these instructions may result in improper installation, adjustment, service or maintenance possibly resulting in fire, electrical shock, property damage, personal injury or death.

### WARNING

The manufacturer's warranty does not cover any damage or defect to the gas/electric unit caused by the attachment or use of any components, accessories or devices (other than those authorized by the manufacturer) into, onto or in conjunction with the gas/electric unit. You should be aware that the use of unauthorized components, accessories or devices may adversely affect the operation of the gas/electric unit and may also endanger life and property. The manufacturer disclaims any responsibility for such loss or injury resulting from the use of such unauthorized components, accessories or devices.

### WARNING

Do not, under any circumstances, connect return ductwork to an other heat producing device such as a fireplace insert, stove, etc. Unauthorized use of such devices may result in fire, Carbon Monoxide poisoning, explosion, property damage, severe personal injury or death.

### WARNING

This unit is designed certified for outdoor installation only. Installation inside any part of a structure can result in inadequate unit performance as well as property damage. Installation inside can also cause recirculation of flue products into the conditioned space resulting in personal injury or death.

### WARNING

The spark ignitor and ignition lead from the ignition control are high voltage. Keep hands or tools away to prevent electrical shock. Shut off electrical power before servicing any of the controls. Failure to adhere to this warning can result in personal injury or death.

### WARNING

Proposition 65: This appliance contains fiberglass insulation. Respirable particles of fiberglass are known to the state of California to cause cancer. Exhaust gas from this appliance contains chemicals, including carbon monoxide, known to the state of California to cause birth defects of other reproductive harm.

### WARNING

Never allow products of combustion or the flue products to enter the return air ductwork, or the circulating air supply. All return ductwork must be adequately sealed and secured to the furnace with sheet metal screws, and joints taped. All other duct joints must be secured with approved connections and sealed airtight. Failure to prevent products of combustion from being circulated into the living space can create potentially hazardous conditions, including Carbon Monoxide poisoning that could result in personal injury or death.

### WARNING

Holes in the exhaust transition or heat exchanger can cause toxic fumes to enter the home. The exhaust transition or heat exchanger must be replaced if they have holes or cracks in them. Failure to do so can cause Carbon Monoxide poisoning resulting in personal injury or death.

**⚠ WARNING**

Do not attempt to manually light this furnace with a match or any open flame. Attempting to do so can cause fire or explosion resulting in property damage, personal injury or death.

**⚠ WARNING**

Should overheating occur or the gas supply fail to shut off. Shut off the Manual Gas valve to the appliance before shutting off the supply. Failure to do so can result in an explosion or fire causing property damage, severe personal injury or death.

**⚠ WARNING**

Disconnect all power to the unit before starting maintenance. Failure to do so can result in severe electrical shock or death. Regular maintenance will reduce the buildup of contaminants and help to protect the unit's finish.

**⚠ WARNING**

Turn off the main electrical power at the branch circuit disconnect closest to the unit before attempting any wiring. Failure to do so can cause electrical shock resulting in personal injury or death.

**⚠ WARNING**

**DO NOT JUMPER THIS DEVICE!** Do not reset the overtemperature control without taking corrective action to assure that an adequate supply of combustion air is maintained under all conditions of operation. Failure to do so can result in Carbon Monoxide poisoning or death. Replace this control only with the identical replacement part.

**⚠ WARNING**

Label all wires prior to disconnection when servicing controls. Wiring errors can cause improper and dangerous operation resulting in fire, electrical shock, property damage, personal injury or death.

**⚠ WARNING**

This unit is equipped at the factory for use on Natural Gas only. Conversion to LP Gas requires a special kit enclosed instructions with. **DO NOT BURN ANY LIQUID FUEL OR SOLID FUEL IN THIS UNIT.** Burning any unapproved fuel will result in damage to this unit heat exchanger, which could result in fire, Carbon Monoxide poisoning, explosion, personal injury, property damage or death.

**⚠ WARNING**

Install this unit only in a location and position as specified in the location requirements and considerations section of these instructions. Provide adequate combustion and ventilation air to the unit space as specified in the venting section of these instructions.

**⚠ WARNING**

Do not use this unit during construction if air laden corrosive compounds are present such as chlorine and fluorine. Otherwise, provisions must be taken to provide clean, uncontaminated combustion and ventilation air to the unit, combustion and ventilation air contaminated with these compounds forms acids during combustion which corrodes the heat exchanger and component parts, some of these contaminants are found in, but not limited to, paneling, dry wall, adhesives, paints, stains, varnishes, sealers, and masonry cleaning materials.

**⚠ WARNING**

**FIRE, EXPLOSION, ELECTRICAL SHOCK, AND CARBON MONOXIDE POISONING HAZARD**

Failure to follow this warning could result in dangerous operation, serious injury, death or property damage. Improper installation, adjustment, alteration, service, maintenance or use could cause carbon monoxide poisoning, explosion, fire, electrical shock or other conditions which may cause personal injury or property damage. Consult a qualified service agency, local gas supplier or your distributor or branch for information or assistance. The qualified service agency must use only factory-authorized and listed kits or accessories when modifying this product.

## **WARNING**

Always install unit to operate within the unit's intended temperature-rise range with a duct system which has an external static pressure within the allowable range, as specified in ducting section of these instructions, see also unit rating plate.

## **CAUTION**

### **FURNACE RELIABILITY HAZARD**

Improper installation or misapplication of furnace may require excessive servicing or cause premature component failure.

Application of this furnace should be outdoors with special attention given to vent sizing and material, gas input rate, air temperature rise, unit leveling, and unit sizing.

## **CAUTION**

### **CUT HAZARD**

Failure to follow this caution may result in personal injury.

Sheet metal parts may have sharp edges or burrs. Use care and wear appropriate protective clothing, safety glasses and gloves when handling parts and servicing furnaces.

## **CAUTION**

R410A systems operate at higher pressures than R22 systems.

Do not use R22 service equipment or components on R410A equipment.

## **WARNING**

### **ELECTRICAL SHOCK, FIRE OR EXPLOSION HAZARD**

Failure to follow safety warnings exactly could result in dangerous operation, serious injury, death or property damage. Improper servicing could result in dangerous operation, serious injury, death or property damage.

- Before servicing, disconnect all electrical power to furnace.
- When servicing controls, label all wires prior to disconnecting.  
Reconnect wires correctly.
- Verify proper operation after servicing.

Improper installation, adjustment, alteration, service, Maintenance, or use can cause explosion, fire, electrical shock, or other conditions which may cause death, personal injury, or property damage. Consult a qualified installer, service agency, or your distributor or branch for information or assistance. The qualified installer or agency must use factory-authorized kits or accessories when modifying this product.

Refer to the individual instructions packaged with the kits or accessories when installing.

Follow all safety codes. Wear safety glasses, protective clothing, and work gloves. Have a fire extinguisher available. Read these instructions thoroughly and follow all warnings or cautions include in literature and attached to the unit. Consult local building codes, the current editions of the National Fuel Gas Code (NFGC) NFPA 54/ANSI Z223.1 and the National Electrical Code (NEC) NFPA 70.

A manufactured (mobile) home installation must conform with the Manufactured Home Construction and Safety Standard, Title 24 CFR, Part 3280, or when this Standard is not applicable, the Standard for Manufactured Home Installations (Manufactured Home Sites, Communities and Set-Ups), ANSI/NCS A225.1, and/or MH Series Mobile Homes, CAN/CSA Z240.

In Canada, refer to the current editions of the National Standards of Canada CAN/CSA-B149.1 and .2 Natural Gas and Propane Installation Codes, and Canadian Electrical Code CSA C22.1

Recognize safety information. This is the safety-alert symbol . When you see this symbol on the unit and in instructions or manuals, be alert to the potential for personal injury. Understand the signal words DANGER, WARNING, and CAUTION. These words are used with the safety-alert symbol.

DANGER identifies the most serious hazards which will result in severe personal injury or death. WARNING signifies hazards which could result in personal injury or death. CAUTION is used to identify unsafe practices which may result in minor personal injury or product and property damage. NOTE is used to highlight suggestions which will result in enhanced Installation, reliability, or operation.

- Use only with type of gas approved for this unit. Refer to the unit rating plate.
- Install this unit only in a location and position as specified in the "Installation" section of these instructions.
- Provide adequate combustion and ventilation air to the unit space as specified in "Safety" section.
- Never test for gas leaks with an open flame. Use a commercially available soap solution made specifically for the detection of leaks to check all connections, as specified in the "Gas Supply, Condensate drain and Piping" section.
- Always install unit to operate within the furnace's intended temperature-rise range with a duct system which has an external static pressure within the allowable range, as specified in the "Safety" section. See also unit rating plate.
- When unit is installed so that supply ducts carry air circulated by the furnace to areas outside the space containing the furnace, the return air shall also be handled by duct(s) sealed to the furnace casing and terminating outside the space containing the furnace. See "Ductwork" and "Return Air" section.
- The unit may be used for construction heat provided that the furnace installation and operation complies with the CAUTION and WARING instructions in this manual.
- The unit is design-certified for use with natural and propane gases (see unit rating plate) and for installation in outside only. The unit is factory-shipped for use with natural gas.

A listed accessory gas conversion kit is required to convert unit for use with propane gas. The LP conversion kit is included with the unit.

- The unit must be kept free and clear of insulating materials. Inspect surrounding area to ensure insulation material is in safe distance when installing furnaces or adding insulation materials. Insulation materials may be combustible. See Table 3-1 for required clearances to combustible construction.
- Before heating season begins, exam the unit to determine that:
  - a. All flue gas carrying areas external to the unit (i.e. chimney, vent connector) are clear and free of obstructions.
  - b. The vent connector is in place, slopes upward and is physically sound without holes or excessive corrosion.
  - c. The return-air duct connection(s) is physically sound, is sealed to the furnace casing, and terminates outside the space containing the furnace.
  - d. The physical support of the unit is sound without sagging, cracks, gaps, etc around the base so as to provide a seal between the support and the base.
  - e. There are no obvious sign of deterioration of the unit.
  - f. The burner flames are in good adjustment (by comparison with pictorial sketches of the main burner flame.

- Furnace operation needs air for combustion and ventilation. Do not block or obstruct air openings on furnace or spacing around furnace required for supplying sufficient combustion air and ventilation.

## 1.1 Inspection

As soon as unit is received, it should be inspected and noted for possible shipping damage during transportation. It is shipper's responsibility to cover the cost of shipping damage. Manufacturer or distributor will not accept the claims from dealer for any transportation damage.

## 1.2 Limitations

Refer to Fig. 2-2, 2-3 for unit physical data and to Table 7-1 for electrical data. If components are to be added to a unit they must meet local codes, they are to be installed at the dealer's and /or the customer's expense. Size of unit for proposed installation should be based on heat loss / heat gain calculations made in accordance with industry recognized procedures identified by the Air conditioning contractors of America.

**Note: Rating plate must be left visible for future reference.**

### FOR YOUR SAFETY READ BEFORE OPERATING



**WARNING**



If you do not follow these instructions exactly, a fire or explosion may result causing property damage, personal injury or loss of life.

- A. This appliance does not have a pilot. it is equipped with an ignition device which automatically lights the burner.  
**Do not** try to light the burner by hand.
- B. **BEFORE OPERATING** smell all around the appliance area for gas. Be sure to smell next to the floor because some gas is heavier than air and will settle on the floor.

#### FOR YOUR SAFETY WHAT TO DO IF YOU SMELL GAS

- Do not try to light any appliance.
- Do not touch any electrical switch; do not use any phone in your building.
- Immediately call your gas supplier from a

neighbors' phone. Follow the gas suppliers instructions.

- If you cannot reach your gas supplier, call the fire department.
- C. Use only your hand to turn the gas control switch. Never use tools. If the switch will not turn by hand, don't try to repair it; call a qualified service technician. Force or attempted repair may result in a fire or explosion.
- D. Do not use this appliance if any part has been under water. Immediately call a qualified service technician to inspect the appliance and to replace any part of the control system and any gas control which has been under water.

### OPERATING INSTRUCTIONS

1. STOP! Read the safety information above on this label.
2. Set the thermostat to lowest setting.
3. Turn off all electric power to the appliance.
4. This appliance is equipped with an ignition device which automatically lights the burner. Do not try to light the burner by hand.

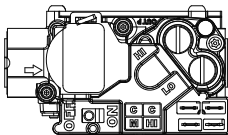

**SWITCH SHOWN IN THE "OFF" POSITION**

5. Remove control access panel.
6. Wait five (5) minutes to clear out any gas. if you then smell gas, STOP! Follow "B" in the safety information above on this label. If you don't smell gas, go to the next step.
7. Push gas control switch to "ON".  
NOTE: Do not force.
8. Replace control access panel.
9. Turn on all electric power to the appliance.
10. Set thermostat to desired setting
11. If the appliance will not operate, follow instructions "To Turn Off Gas To Appliance" and call your service technician or gas supplier.

### TO TURN OFF GAS TO APPLIANCE

1. Set the thermostat to lowest setting.
2. Turn off all electric power to the appliance if service is to be performed.
3. Remove control access panel.
4. Push gas control to "OFF". Do not force.
5. Replace control access panel.

See Fig: Instruction of lighting/ shutdown operation. Should the gas supply fail to shut off or if overheating occurs, shut off the gas valve to the furnace before shutting of the electrical supply.

## 2 INTRODUCTION

A Package Gas Electric Unit is a fully self-contained, combination gas heating/electric cooling unit designed for outdoor installation. All unit sizes have return and discharge openings for both horizontal and downflow configurations, and are factory shipped with all downflow duct openings covered. Units may be installed either on a rooftop or on a cement slab.

In gas heating mode, this unit is designed for a minimum continuous return-air temperature and a maximum continuous return-air temperature. Failure to follow these return-air temperature limits may affect reliability of heat exchangers, motors, and other components.

This booklet contains the installation and operating instructions for your Package Gas Electric Unit. There are some precautions that should be taken to derive maximum satisfaction from it. Improper installation can result in unsatisfactory operation or dangerous conditions. Read this booklet and any instructions packaged with separate equipment required to make up the system prior to installation. Give this booklet to the owner and explain its provisions.

The owner should retain this booklet for future reference.

A Package Gas Electric Unit includes a hermetically-sealed refrigerating system consisting of a compressor, condenser coil, evaporator coil with thermal expansion valve (TXV) or throttle valve, a circulation air blower, a condenser fan, a heat exchanger assembly, gas burner and control assembly, combustion air motor and fan, and all necessary internal electrical wiring. The cooling system of these units is factory-evacuated, charged and performance tested. All units are factory charged with Refrigerant R410A.

The figure shown in this manual is for reference only and may be slightly different from the actual product.

**J4PG4024E1060AA, J4PG4030E1060AA, J4PG4036E1090AA, J4PG4042E1090AA**

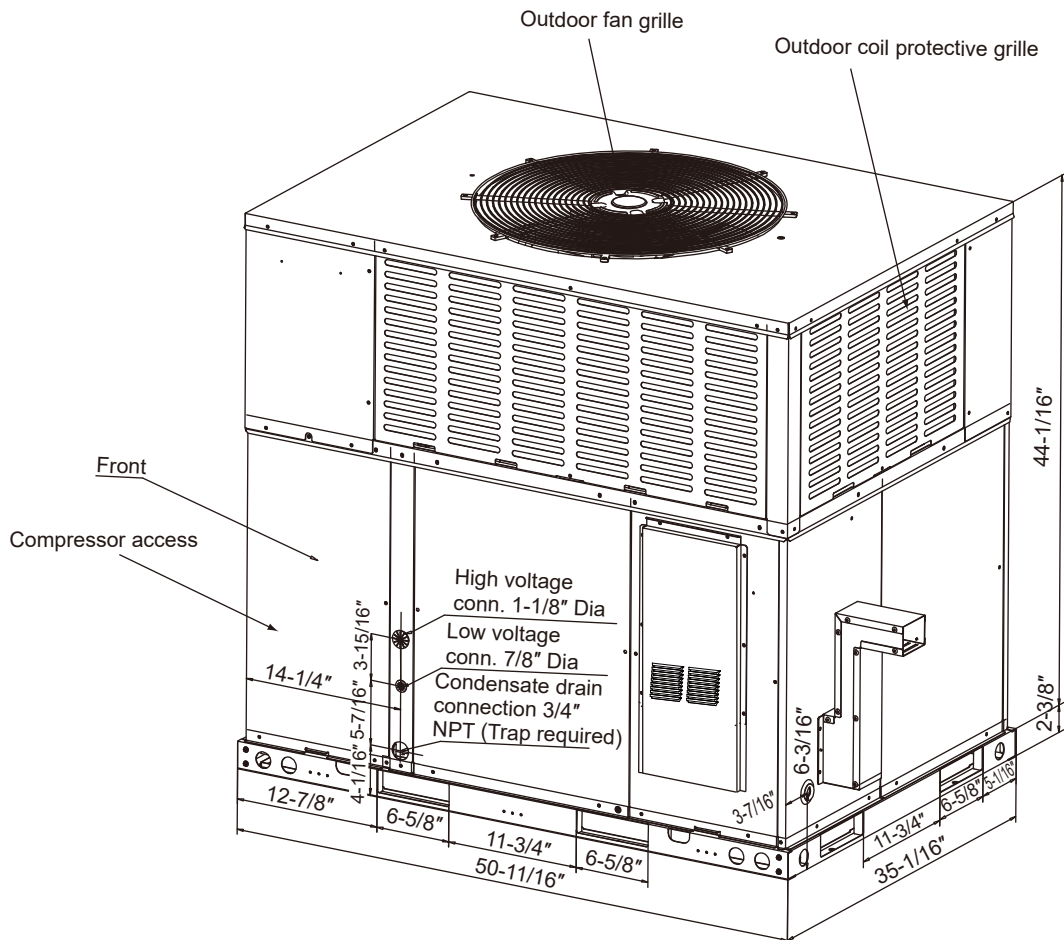

Fig. 2-1 Unit Dimensions

\* The above figure for reference purpose only.

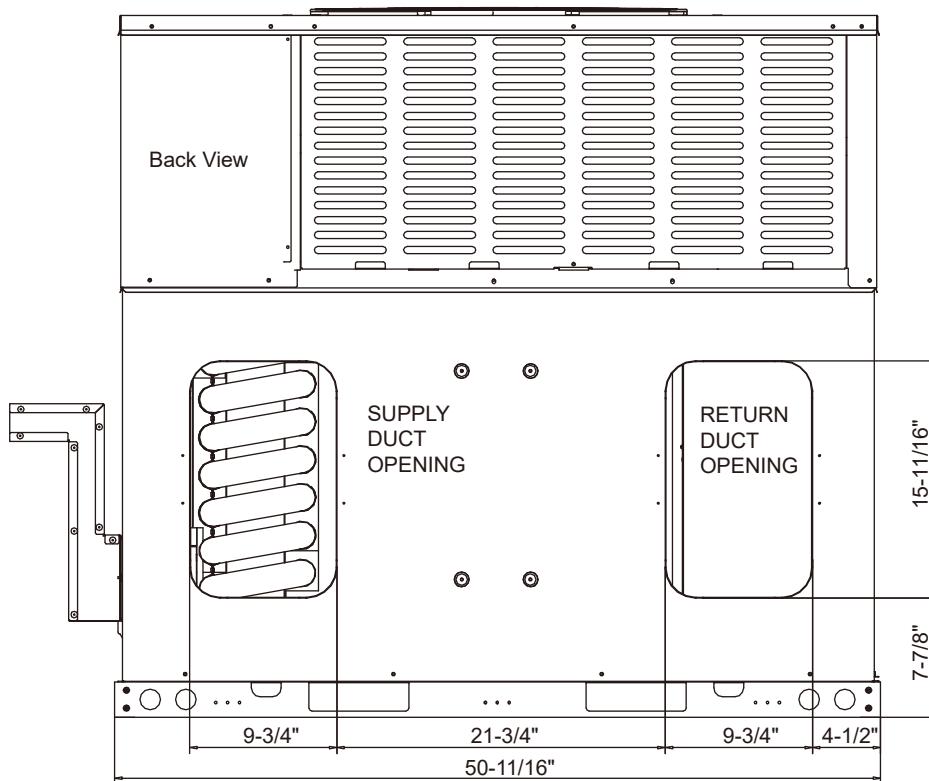
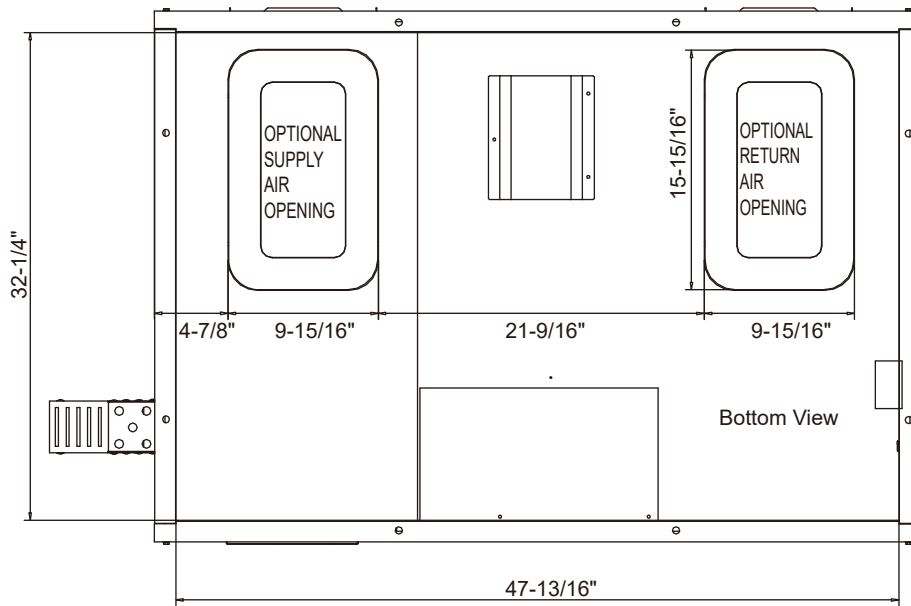

Fig. 2-2 Dimensions Back and Bottom

\* The above figure for reference purpose only.

J4PG4048E1090AA, J4PG4060E1090AA, J4PG4060E1110AA

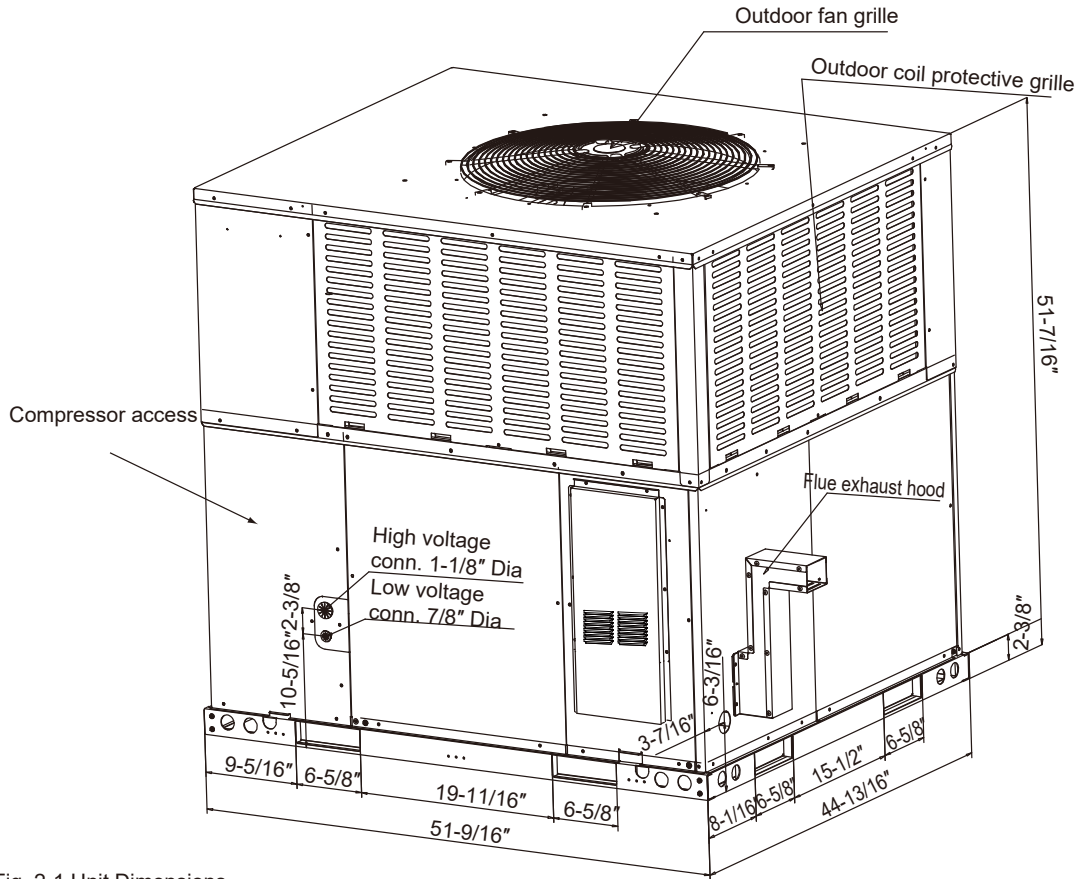
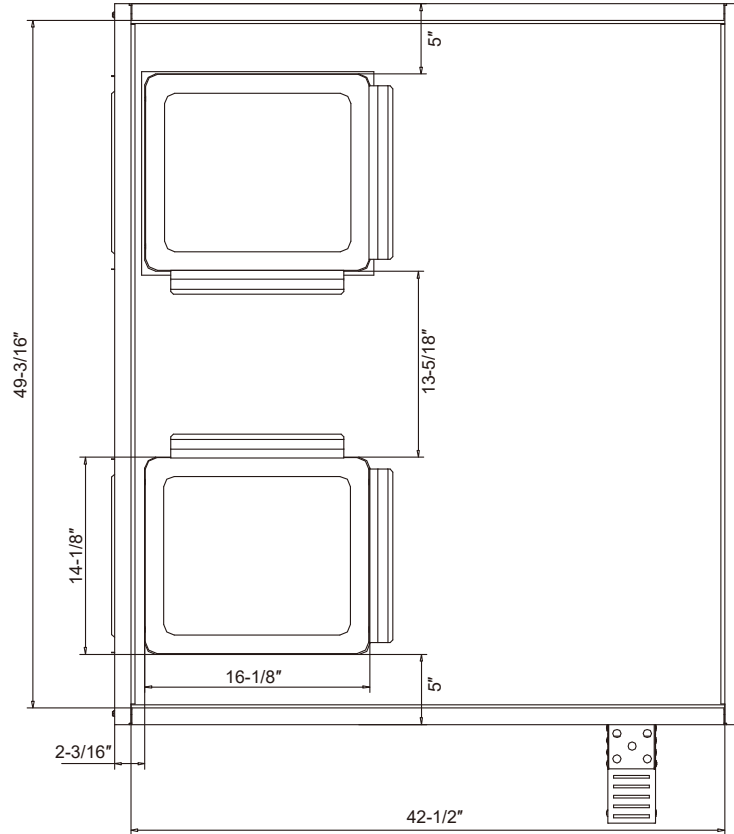

Fig. 2-1 Unit Dimensions



\* The above figure for reference purpose only.

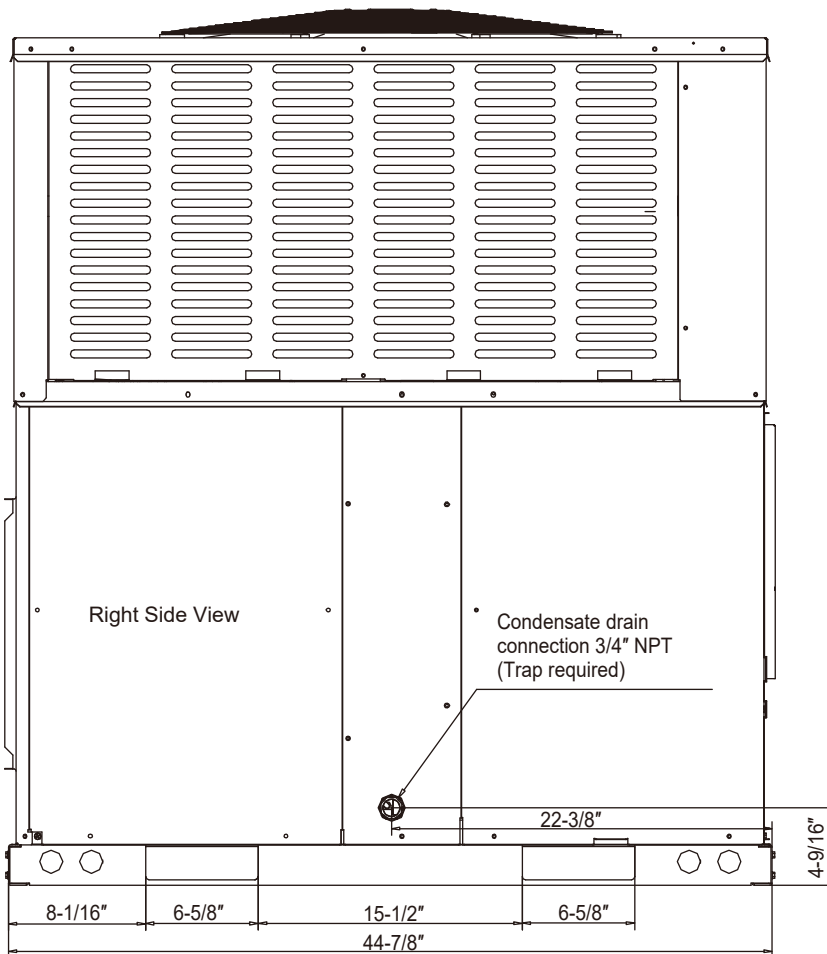
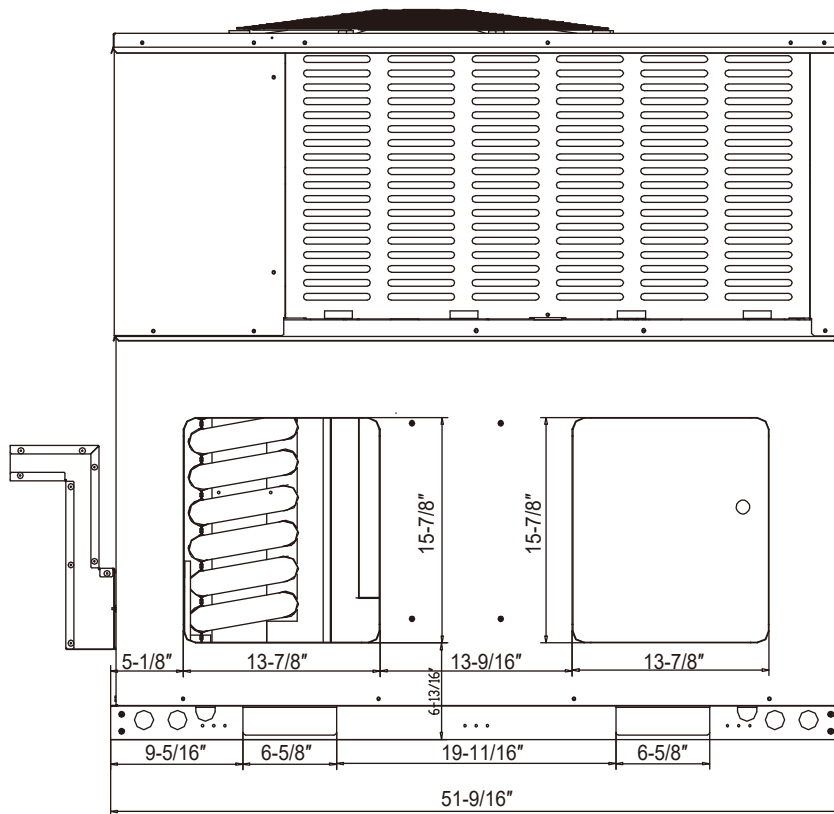

Fig. 2-2 Dimensions Back and Bottom

\* The above figure for reference purpose only.

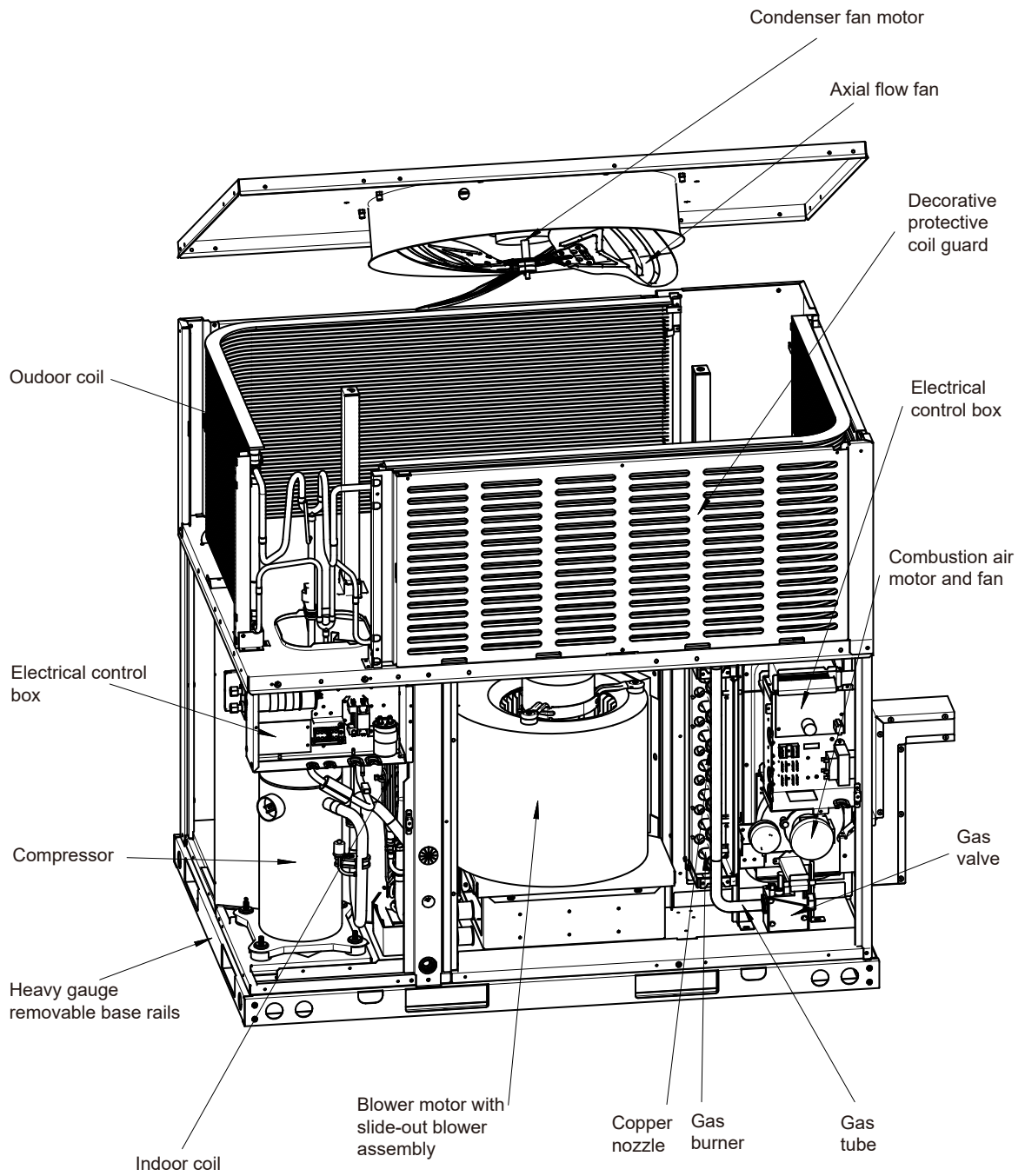

Fig. 2-3 Component Location

\* The above figure for reference purpose only.

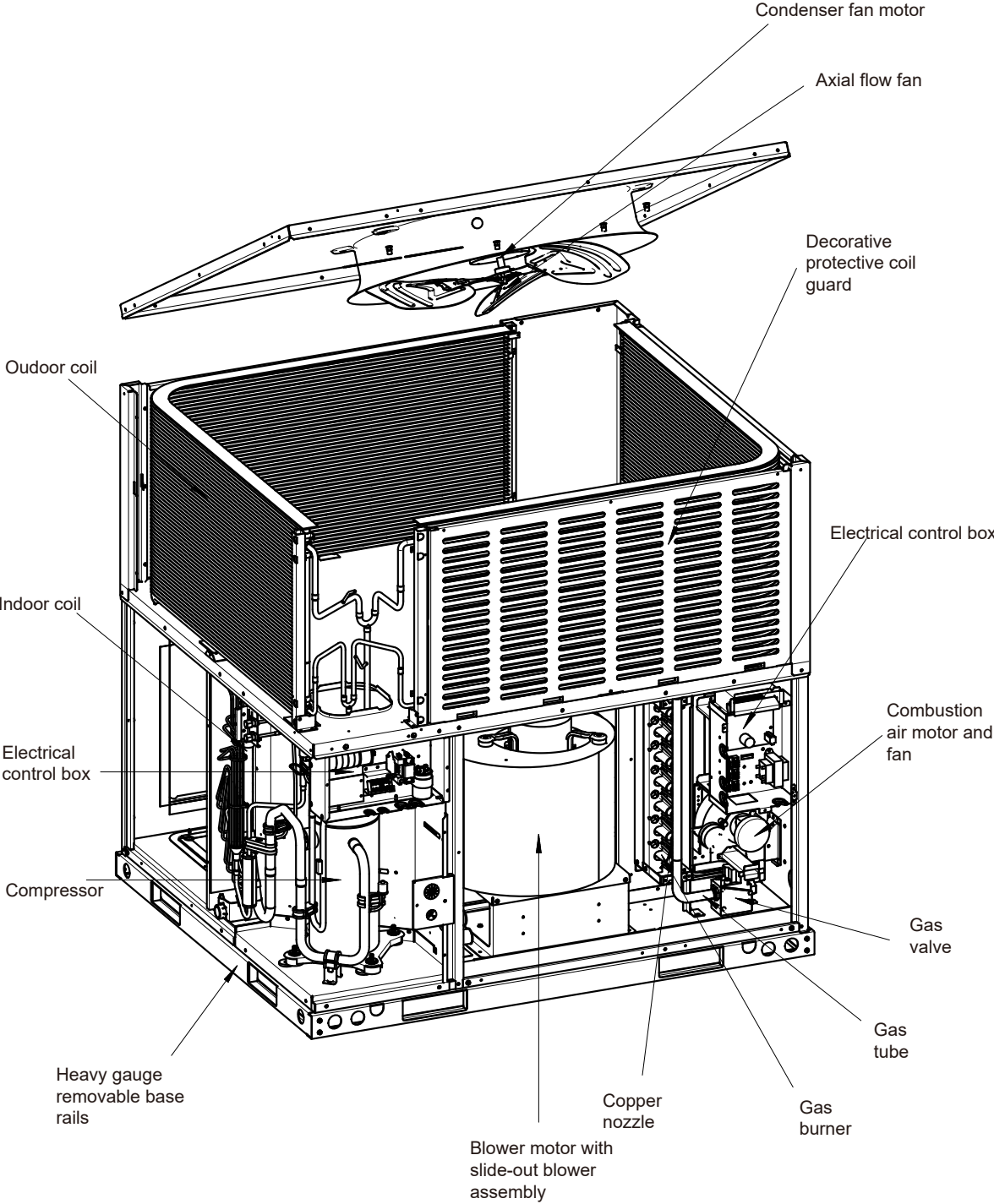

Fig. 2-3 Component Location

\* The above figure for reference purpose only.

## 3 INSTALLATION

Install the unit in accordance with The American National Standard Z223.1-latest edition booklet entitled "National Fuel Gas Code", and the requirements or codes of the local utility or other authority having jurisdiction.

Unit should be installed in accordance with national and local safety codes, including but not limit to ANSI/NFPA No. 70 or Canadian Electrical Code Part 1, C22.1, local plumbing and wastewater codes and any other applicable codes.

Additional helpful publications available from the "National Fire Protection Association" are: NFPA-90A - installation of Air Conditioning and Ventilating Systems 1985 or latest edition. NFPA-90B - Warm Air Heating and Air Conditioning Systems 1984.

### 3.1 Pre-installation Check-points

Before installation, carefully check the following:

1. For rooftop installation, be sure the structure has enough strength to support the weight of unit.
2. Clearances and provision for servicing.
3. Power supply and wiring.
4. Gas supply and piping.
5. Air duct connections and sizing.
6. Drain facilities and connections.
7. Location for minimum noise and vibration.
8. The blue pearl cottons are for transportation protection and needs to be taken out

### 3.2 Location Considerations

The metal parts of the unit may be subject to rust or deterioration in adverse environmental conditions. This oxidation could shorten the equipment's useful life. Salt spray, fog or mist in seacoast areas, sulphur or chlorine from lawn watering systems, and various chemical contaminants from industries such as paper mills and petroleum refineries are especially corrosive.

**If the unit is to be installed in an area where contaminants are likely to be a problem, give special attention to the equipment location and exposure:**

1. Avoid having lawn sprinkler heads spray directly on the unit cabinet.
2. In coastal areas locate the unit on the side of the building away from the waterfront.

#### WARNING

Disconnect all power to the unit before starting maintenance.  
Failure to do so can cause electrical shock resulting in personal injury or death.

3. Shielding by a fence or shrubs may give some protection.
4. Elevate the unit off its slab or base enough to allow air circulation and avoid holding water against the base pan.
5. Frequent washing of the cabinet, fan blade and coil with fresh water will remove most of the salt or other contaminants that build up on the unit.
6. Regular cleaning and waxing of the cabinet with a good automobile polish will provide some protection.

Several different types of protective coatings are offered in some areas. These coatings may provide some benefit, but the effectiveness of such coating materials cannot be verified by the equipment manufacturer. The best protection is frequent cleaning, maintenance and minimal exposure to contaminants.

### 3.3 Outside Installation

#### WARNING

This unit is designed certified for outdoor installation only.

Installation inside any part of a structure can result in inadequate unit performance as well as property damage. Installation inside can also cause recirculation of flue products into the conditioned space resulting in personal injury or death.

Typical outdoor installation is shown in Figure 3-2:

1. Select a location where external water drainage cannot collect around unit.
2. Locate unit where operating sounds will not disturb owner or neighbors.
3. The location of the unit should allow proper access for inspection and servicing.
4. Locate unit so roof runoff water does not pour directly on the unit. Provide gutter or other shielding at roof level. Do not locate unit in an area where excessive snow drifting may occur or accumulate.
5. Provide a concrete slab extending 3" beyond all four sides of the unit. The slab should be sufficiently high enough above grade to prevent surface water from entering the unit. The slab should be isolated from the foundation wall.
6. Pitch the slab approximately 1/2" so that the unit will be pitched toward the drain. See Figure 3-3.
7. It is essential that the unit be elevated above the base pad to allow for defrost water runoff, condensate drainage, and possible refreezing or condensate. Route condensation off the base pad to an area that will not become slippery and result in personal injury. Important: Do not interfere with opening in bottom of unit.
8. Where snowfall is anticipated, the height of the unit above the ground level must be considered. Mount unit high enough to be above average area snowfall to prevent snow from blocking the outdoor coil, to allow condensate runoff, and to allow combustion air to enter the combustion air inlet.

### 3.4 Attaching Exhaust and Combustion Air Inlet Hoods

-: Do not operate this unit without the exhaust and combustion air inlet hood properly installed. These hoods are shipped in a carton in the return air compartment inside the unit and must be attached the unit is installed. See Fig. 2-1.

To attach exhaust and combustion air inlet hood:

1. Remove 3 screws securing filter access panel and remove filter access panel. For location of filter access panel, see Fig.3-4.
2. Remove both exhaust and combustion air inlet hoods from their carton, located inside the return air compartment.

3. Attach filter access panel.
4. Attach the combustion air inlet hood and the exhaust hood with 4 and 6 screws as shown in Fig. 2-1. Screws are in parts bag shipped in the burner compartment.
5. Vent the unit using the flue exhaust hood, as supplied from the factory, without alteration addition. The only exception is with factory approved additions. Consult your local unity or other authority having jurisdiction for accepted venting techniques.

### 3.5 Cover Panel Installation / Conversion Procedure

All unit sizes have return and discharge openings for both horizontal and downflow configurations, and are factory shipped with all downflow duct openings covered, HORIZONTAL is factory shipped.

#### HORIZONTAL TO DOWNFLOW

1. Remove screws and covers from the supply and return bottom section.
2. Install gasket (supplied with parts bag) around perimeter of cover on the insulate side.
3. Secure covers to the side of the unit using existing screws and those supplied in the parts bag. See Fig.3-4.
4. Seal duct covers with silicone caulk.

#### DOWNFLOW TO HORIZONTAL

1. Remove screws and covers from the supply and return bottom section.
2. Install gasket (factory shipped) around perimeter of cover on the insulate side.
3. Secure covers to the bottom of the unit using existing screws and those supplied in the parts bag. See Fig. 3-5

#### **⚠ WARNING**

This unit must not be installed directly on wood flooring, Class A, Class B or Class C roof covering materials, or any other combustion structure except as specified in Fig.3-1. Failure to adhere to this warning can cause a fire or explosion resulting in property damage, personal injury or death.

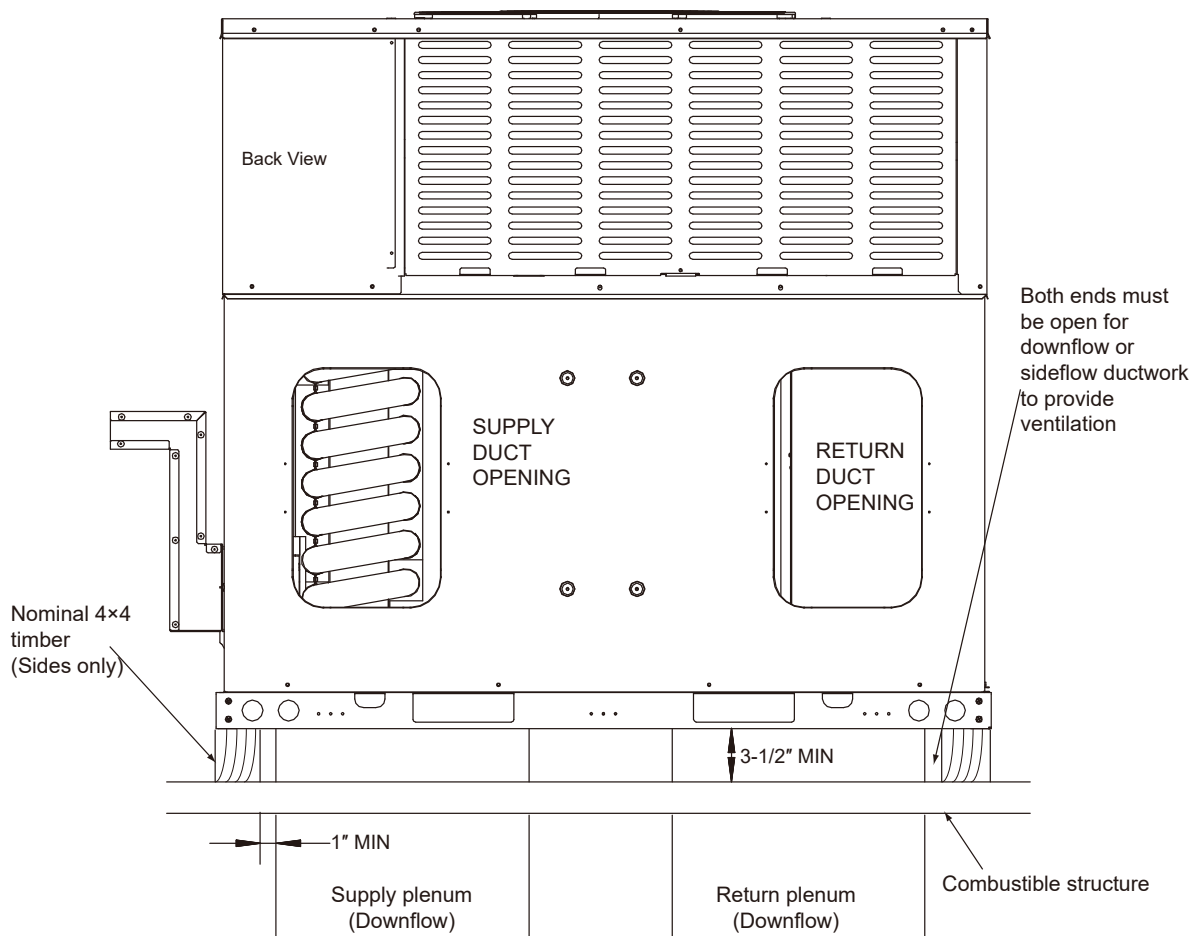

Fig. 3-1 Exception to non-combustible flooring requirement

\* The above figure for reference purpose only.

### 3.6 Clearance

All units require certain clearance for proper operation and service.  
Refer to Table 3-1 for the minimum clearances required for construction, servicing and proper unit operation.

Direction	Distance (in.)	Direction	Distance (in.)
Top <sup>1</sup>	60	Right	24
Front	48	Left	12 <sup>4</sup>
Rear	18 <sup>2</sup>	Bottom <sup>3</sup>	0

Table 3-1: Unit Clearance

Duct clearance: 1 inch clearance for all sides of air supply duct.

- Units must be installed outdoors. Over hanging structure or shrubs should not obscure condenser air discharge outlet.
- The minimum clearance without economizer/fresh air damper. For distance with Economizer/fresh air damper, please refer to the relevant Install requirement.
- Units may be installed on combustible floors made from wood or class A, B or C roof covering materials.
- If Economizer/fresh air damper is used, a 24" minimum clearance is required on left side of unit.

#### NOTE

For units applied with a roof curb, the minimum clearance may be reduced from 1 inch to 1/2 inch between combustible roof curb material and this supply air duct.

### 3.7 Rigging and Handling

Exercise care when moving the unit. Do not remove any packaging until the unit is near the place of installation. Rig the unit by attaching chain or cable slings to the lifting holes provided in the base rails.

Spreader bars, whose length exceeds the largest dimension across the unit, **MUST** be used across the top of the unit.

#### CAUTION

Before lifting, make sure the unit weight is distributed equally on the rigging cables so it will lift evenly.

Units may be moved or lifted with a forklift. Slotted openings in the base rails are provided for this purpose.

#### CAUTION

All panels must be secured in place when the unit is lifted.  
The condenser coils should be protected from rigging cable damage with plywood or other suitable material.

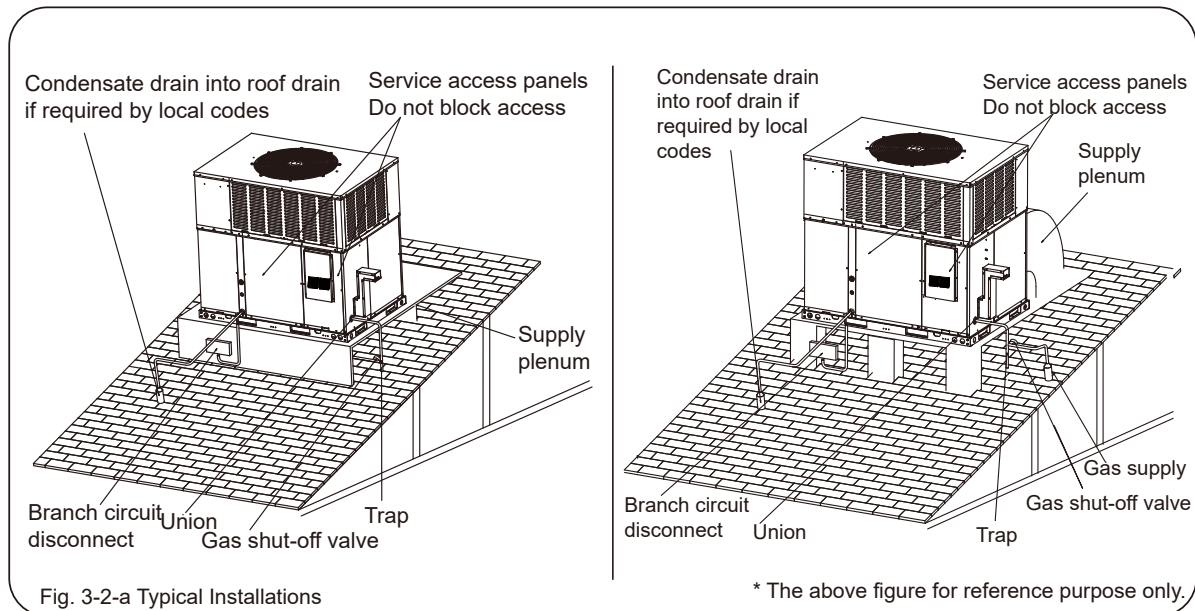

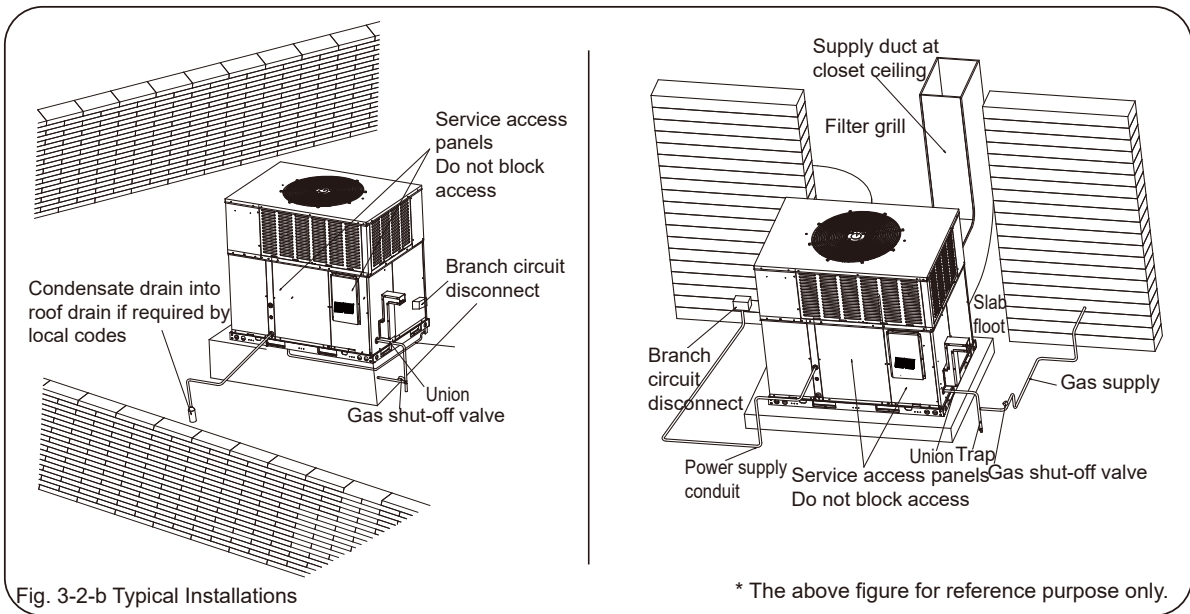

**NOTE**

A unit with electric heaters with an inlet or outlet duct that penetrates the building structure supporting the unit shall be provided with a mounting base of noncombustible material so designed that, after the unit is installed, there will be no open passages through the supporting structure that would permit flame or hot gases from a fire originating in the space below the supporting structure to travel to the space above that structure. If the unit is intended to be installed on a supporting structure of combustible material, the base shall be so designed that the required clearance will be maintained between the supporting structure and the unit, plenum, and attached duct. Spacers necessary to provide required clearances shall be attached to the unit mounting base, and shall extend not less than 76 mm (3 in.) below the upper surface of the supporting structure, except that, in a unit designed for use only in a mobile home, the distance shall not be less than 19 mm (3/4 in.).

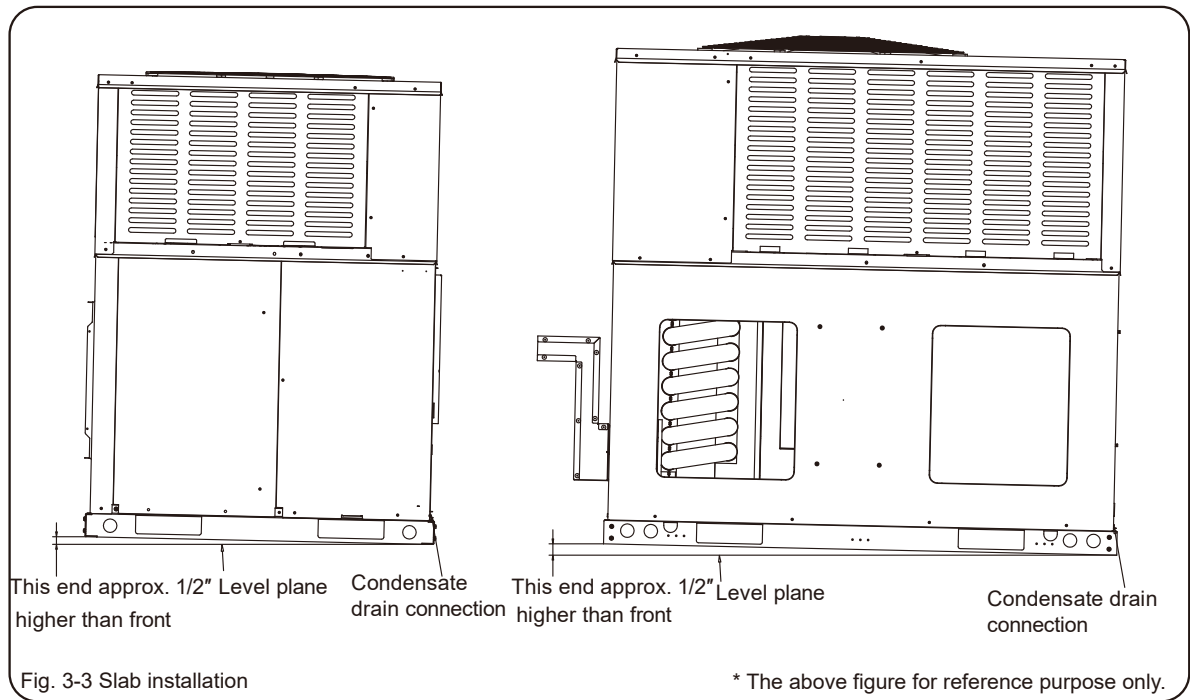

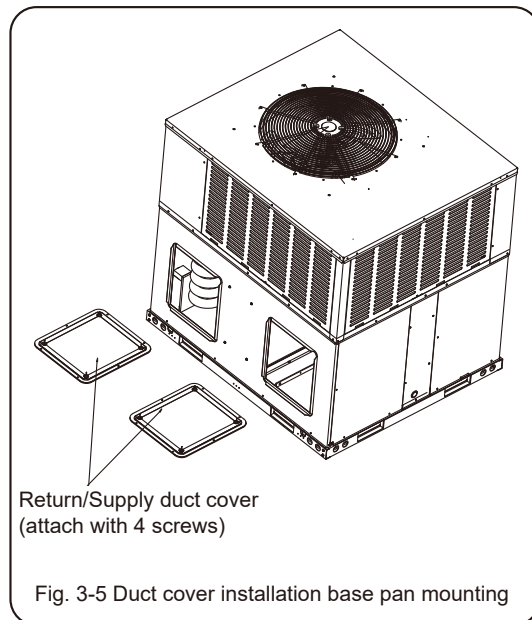
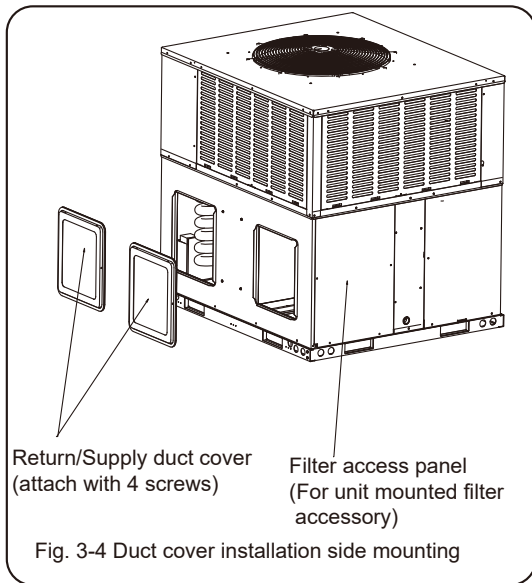

\* The above figure for reference purpose only.

### 3.8 Roof Curb

In applications using roof curbs, the unit must be placed on the curb so that the front of the unit is tightly close to curb. (See Fig.3-6 Roof Curb Dimension)

#### NOTE

For units applied with a roof curb, the minimum clearance may be reduced from 1 inch to 1/2 inch between combustible roof curb material and this supply air duct.

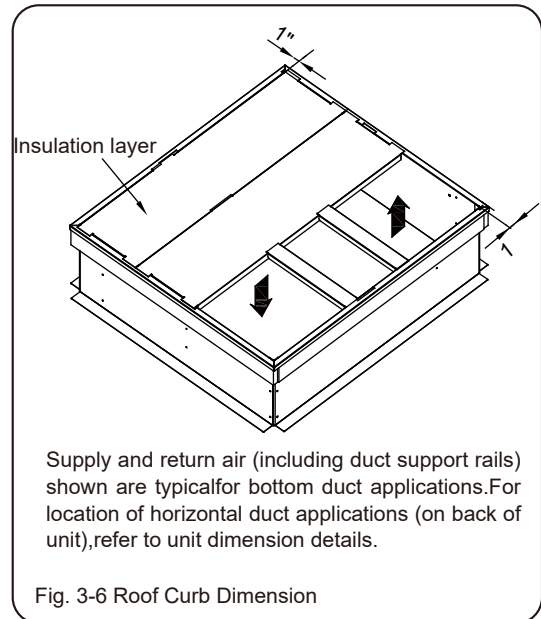

\* The above figures for reference purpose only.

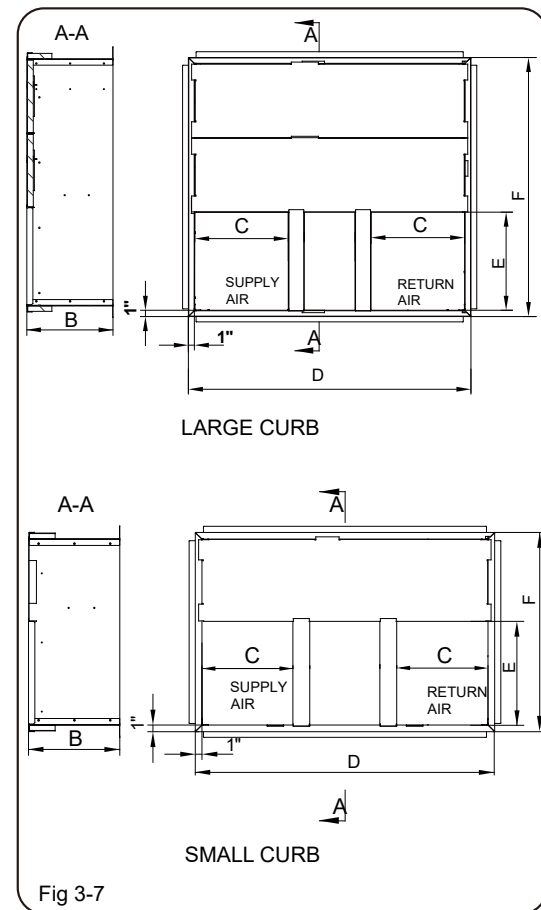

\* The above figures for reference purpose only.

Dimensions(Inches)	CURB	
	LARGE	SMALL
"B" in.[mm]	14-1/4 [362]	14-1/4 [362]
"C" in.[mm]	15-1/4 [387]	14 [356]
"D" in.[mm]	46-1/16 [1170]	46-1/16 [1170]
"E" in.[mm]	16 [406]	16 [406]
"F" in.[mm]	42-3/16 [1070]	30-5/8 [778]

Table 3-2

### 3.9 Ductwork

Ductwork should be made and sized by installer and in accordance with Air Manual from Conditioning Contractors of America and local codes.

#### NOTE

On ductwork exposed to outside air conditioning space, use at least 2" of insulation and a vapor barrier. Flexible joint may be used to reduce noise.

These units are adaptable to horizontal use as well as rear supply and return air duct openings. To convert to downflow, use the steps is shown in 3.5.

A closed return duct system shall be used. This shall not preclude use of economizers or ventilation air intake. Flexible joints may be used in the supply and return duct work to minimize the transmission of noise.

#### CAUTION

When fastening duct work to the side duct flanges on the unit, insert the screws through the duct flanges only. DO NOT insert the screws through the casing. Outdoor duct work must be insulation and waterproofed.

#### NOTE

Be sure to note supply and return openings. Refer to Fig. 3 and 4 for information concerning rear and bottom supply and return air duct openings.

### 3.10 Return Air

#### WARNING

Never allow products of combustion to the flue products to enter the return air ductwork, or the circulating air supply.

All return ductwork must be adequately sealed and secured to the furnace with sheet metal screws, and joints taped. All other duct joints must be secured with approved connections and sealed airtight.

Failure to prevent products of combustion from being circulated into the living space can create potentially hazardous conditions, including carbon monoxide poisoning that could result in personal injury or death.

### 3.11 Filters

The installer must install field supplied filters in the return air duct. A field installed filter grille is recommended for easy and convenient access to the filters for periodic inspection and cleaning. Filters must have adequate face area for the rated air quantity of the unit. See air delivery tables for recommended filter size.

## 4 GAS SUPPLY, CONDENSATE DRAIN AND PIPING

### 4.1 Gas Connection

**IMPORTANT:** Connect this unit only to gas supplied by a commercial utility.

1. Install gas piping in accordance with local codes and regulations of the local utility company. In the absence of local codes, the installation must conform to the specifications of the National Fuel Gas Code, ANSI Z223.1 - latest edition.

#### NOTE

The use of flexible gas connectors is not permitted. If local codes allow the use of a corrugated stainless steel flexible gas appliance connector, always use a new listed connector. Do not use a connector which has previously serviced another gas appliance.

#### NOTE

The Commonwealth of Massachusetts requires the gas shut-off valve to be a T-handle gas cock.

2. Connect the gas line to the gas pipe inlet opening provided into the 1/2" inlet valve. See Fig. 4-1 for typical piping.
3. Size the gas line to the furnace adequate enough to prevent undue pressure drop and never less than 1/2" nominal pipe size.
4. Install a drip leg or sediment trap in the gas supply line as close to the unit as possible.
5. Install an outside ground joint union to connect the gas supply to the control assembly at the burner tray, Unions may not be installed inside the unit.
6. Gas valves have been factory installed. Install a manual gas valve where local codes specify a shut-off valve outside the unit casting.
7. Make sure piping is tight. A pipe compound resistant to the action of liquefied petroleum gases must be used at all threaded pipe connections.
8. **IMPORTANT:** Any additions, changes or conversions required for the furnace to satisfactorily meet the application should be made by a qualified installer, service agency or the gas supplier, using factory-specified or approved parts. In the commonwealth of Massachusetts, installation must be performed by a licensed plumber or gas fitter for appropriate fuel.

**IMPORTANT:** Disconnect the furnace and its individual shutoff valve the gas supply piping during any pressure testing of that system at test pressures in excess of 1/2 psig or isolate the system from the gas supply piping system by closing its individual manual shutoff valve during any pressures equal to or less than 1/2 psig.

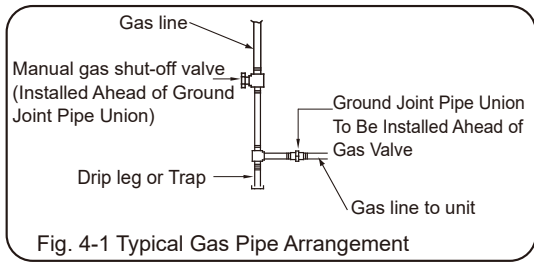

Fig. 4-1 Typical Gas Pipe Arrangement

### ⚠ WARNING

#### FIRE OR EXPLOSION HAZARD

Failure to follow the safety warnings exactly could result in serious injury, death or property damage.

Never test for gas leaks with an open flame. Use a commercially available soap solution made specifically for the detection of leaks to check all connections. A fire or explosion may result causing property damage, personal injury or loss of life.

**TO CHECK FOR GAS LEAKS, USE A SOAP AND WATER SOLUTION OR OTHER APPROVED METHOD. DO NOT USE AN OPEN FLAME.**

**IMPORTANT:** Check the rating plate to make certain the appliance is equipped to burn the type of gas supplied. Care should be taken after installation of this equipment that the gas control valve not be subjected to high gas supply pressure. In making gas connections, avoid strains as they may cause noise and damage the controls. A backup wrench is required to be used on the valve to avoid damage.

The capacity of gas pipe of different diameters and lengths in CFH with pressure drop of 0.5 in. and specific gravity of 0.60 (natural gas) are shown in Table 4-1.

Table 4-1: Natural gas pipe capacity table (CFH - Cubic Feet of Gas Per Hour)

Nominal iron pipe size (in.)	Equivalent length of pipe (ft.)							
	10	20	30	40	50	60	70	80
1/2	132	92	73	63	56	50	46	43
3/4	278	190	152	130	115	105	96	90
1	520	350	285	245	215	195	180	170
1-1/4	1050	730	590	500	440	400	370	350
1-1/2	1600	1100	890	760	670	610	560	530

After determining the pipe length, select the pipe size which will provide the minimum cubic feet per hour required for the gas input rating of the furnace. By formula:

$$CFH = \frac{\text{Furnace input (Btu/h)}}{\text{Heating Value of Gas (Btu/Cubic Foot)}}$$

The gas input of the furnace is marked on the furnace rating plate.

The heating value of the gas (Btu/Cubic Ft.) may be determined by consulting the local natural gas utility or the L.P. gas supplier.

## 4.2 Conversion

### ⚠ WARNING

This unit is equipped at the factory for use on Natural Gas only.

Conversion to LP Gas requires a special kit which is included with the unit. **DO NOT BURN ANY LIQUID FUEL OR SOLID FUEL IN THIS UNIT.** Burning any unapproved fuel will result in damage to this unit heat exchanger, which could result in fire, Carbon Monoxide poisoning, explosion, personal injury, property damage or death.

Convert the valve to use liquefied petroleum (LP) gas by replacing the pressure regulator spring with the conversion kit spring. This LP kit spring allows the regulator to maintain the proper manifold pressure for LP gas. The correct burner LP orifices are included in the kit.

**NOTE:** The LP conversion kit is included with the unit. **See Conversion Kit Index shipped with unit for proper LP kit number. Furnace conversion to LP gas must be performed by a qualified technician.**

Table 4-2: LP gas pipe capacity table (CFH - Cubic Feet of Gas Per Hour)

Nominal iron pipe size (in.)	Equivalent length of pipe (ft.)											
	10	20	30	40	50	60	70	80	90	100	125	150
1/2	275	189	152	129	114	103	96	89	83	78	69	63
3/4	567	393	315	267	237	217	196	182	173	162	146	132
1	1071	732	590	504	448	409	378	346	322	307	275	252
1-1/4	2205	1496	1212	1039	913	834	771	724	677	630	567	511
1-1/2	3307	2299	1858	1559	1417	1275	1181	1086	1023	976	866	787
2	6221	4331	3465	2992	2646	2394	2205	2047	1921	1811	1606	1496

Example (LP): Input Btu requirement of unit, 150000  
Equivalent length of pipe, 60 ft. = 3/4" IPS r

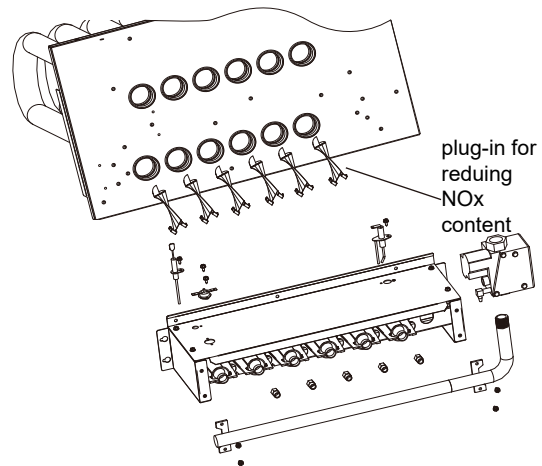

\* The above figure for reference purpose only.

Fig. 4-2 Burner and Gas Valve Arrangement

### 4.3 Adjusting or Checking Furnace Input

Manifold Gas Pressure				
MODEL	Range		Orifice	
	Nature Gas	Propane Gas	Nature Gas	Propane Gas
J4PG4024E1060AA	3.1"W.C	9.6"W.C	51	59
J4PG4030E1060AA	3.1"W.C	9.6"W.C	51	59
J4PG4036E1090AA	3.2"W.C	10.5"W.C	51	59
J4PG4042E1090AA	3.2"W.C	10.5"W.C	51	59
J4PG4048E1090AA	3.3"W.C	9.5"W.C	49	56
J4PG4060E1090AA	3.3"W.C	9.5"W.C	49	56
J4PG4060E1110AA	3.45"W.C	10.0"W.C	49	56

Supply and manifold pressure taps are located on the gas valve body 1/8" N.P.T.

Use a properly calibrated manometer gauge for accurate gas pressure readings.

Only small variations in the gas flow should be made by means of the pressure regulator adjustment. Furnaces functioning on LP gas must be set by means of the tank or branch supply regulators. The furnace outlet pressure should be set at 10" W.C. at the gas control valve.

To adjust the pressure regulator, remove the regulator cap and turn the adjustment screw clockwise to increase pressure or counterclockwise to decrease pressure. Then replace the regulator cap securely.

Any necessary major changes in the gas flow rate should be made by changing the size of the burner orifices. To change orifice spuds, shut off the manual main gas valve and remove the gas manifold.

For elevations up to 2000 feet, rating plate input rating apply. For high altitudes (elevations over 2000 feet), see conversion kit index for derating and orifice spud sizes.

**Check of input is important to prevent over-firing of the furnace beyond its designated input, NEVER SET INPUT ABOVE THAT SHOWN ON THE RATING PLATE. Use the following formula to determine input rate.**

$$\text{C.F.H. Required} = \frac{\text{Heating value of gas (Btu/Cubic ft.)} \times 3600}{\text{Time of Seconds (for 1 Cubic ft.) of gas}}$$

Start the furnace and measure the time required to burn on cubic foot of gas. Prior to checking the furnace input, make certain that all other gas appliances are shut off, with the exception of pilot burners. Time the meter with only the furnace in operation.

**IMPORTANT NOTE FOR ALL ALTITUDES ABOVE 2000 FEET:** The main burner orifices in your furnace and in these kits are sized for the nameplate input and intended for installations at elevations up to 2000 feet in the USA or Canada, or for elevations of 2000-4500 feet in Canada if the unit has been derated at the factory. For elevations above 2000 feet **IN THE USA ONLY** (see ANSI-Z223.1), the burner orifices must be sized to reduce the input 4% for each 1000 feet above sea level.

**NOTICE:** Derating of the heating input for high altitude in the field is unlawful in Canada (refer to CAN/CGA 2.17). Units installed in altitudes greater than 2000 feet must be shipped from the factory or from a factory authorized conversion station with the heating input derated by 10% so as to operate properly in altitudes from 2000-4500 feet.

### 4.4 Condensate Drain

1. Use the provided female NPT threaded fitting for outside connection and make sure that drain holes are not blocked.
2. Insulation may be needed for drain line to prevent sweating.
3. Use a sealing compound on male pipe threads. Install the condensate drain line (NPT) to spill into an open drain.
4. Ensure a trap is included in the condensate drain line.
5. Make sure that the outlet of the trap is at least 1 in. (25 mm) lower than the drain pan condensate connection to prevent the pan from overflowing.

## 5 WIRING

### 5.1 Power Supply

#### WARNING

Turn off the main electrical power at the branch circuit disconnect closest to the unit before attempting any wiring. Failure to do so can cause electrical shock resulting in personal injury or death.

1. All wiring should be made in accordance with the National Electrical Code. Consult the local power company to determine the availability of sufficient power to operate the unit. Check the voltage at power supply to make sure it corresponds to the unit's rated voltage requirement. Install a branch circuit disconnect near the rooftop, in accordance with the N.E.C., C.E.C. or local codes.
2. It is important that proper electrical power is available at the unit. Voltage should not vary more than 10% from that stamped on the unit nameplate. On three phase units, phases must be balanced within 3%.
3. For branch circuit wiring (main power supply to unit disconnect), the minimum wire size for the length of run can be determined from Table 5-1 using the circuit ampacity found on the unit rating plate. Use the smallest wire size allowable in Table 5-1 from the disconnect to unit. The disconnect must be in sight and readily accessible of the unit.

Table 5-1: Branch circuit copper wire size (in.)

		Branch circuit ampacity							
		15	20	25	30	35	40	45	50
Supply wire length (ft.)	200	6	4	4	4	3	3	2	2
	150	8	6	6	4	4	4	3	3
	100	10	8	8	6	6	6	4	4
	50	14	12	10	10	8	8	6	6

**NOTES:**

1. Wire size based on 60°C rated wire insulation and 30°C Ambient Temp.
2. For more than 3 conductors in a raceway or cable, see the N.E.C. for derating the ampacity of each conductor. When installed, the unit must be electrically grounded in accordance with local codes or, in the absence of local codes, with the National Electrical Code, ANSI/NFPA 70, if an external electrical source is utilized.

**IMPORTANT:** This unit is approved for use with copper conductors only connected to unit contactor. Warranty may be jeopardized if aluminum wire is connected to unit contactor.

**Special instructions apply for power wiring aluminum conductors: Warranty is void if connections are not made per instructions.**

Attach a length (6" or more) of recommended size copper wire to the unit contactor terminals L1 and L3 for single phase.

Select the equivalent aluminum wire size from the tabulation below:

Splice copper wire pigtailed to aluminum wire with U.L. recognized connectors for copper-aluminum splices. Please exercise the following instructions very carefully to obtain a positive and lasting connection:

1. Strip insulation from aluminum conductor.
2. Coat the stripped end of the aluminum wire with the recommended inhibitor, and wire brush the aluminum surface through inhibitor.  
INHIBITORS: Brundy-Pentex "A"; Alcoa-No. 2EJC; T & B-KPOR Shield.
3. Clean and recoat aluminum conductor with inhibitor.
4. Make the splice using the below listed wire nuts or split bolt connectors.
5. Coat the entire connection with inhibitor and wrap with electrical insulating tape.

AWG Copper Wire Size	AWG Aluminum Wire Size	Connector Type and Size (or equivalent)
#12	#10	T & B Wire Nut PT2
#10	#8	T & B Wire Nut PT3
#8	#6	Sherman Split Bolt TSP6
#6	#4	Sherman Split Bolt TSP4
#4	#2	Sherman Split Bolt TSP2

## 5.2 Hook-up

To wire unit, refer to the following Fig. 5-1.

Wiring to be done in the field between the unit and devices not attached to the unit, or between separate devices which are field installed and located, shall conform with the temperature limitation for Type T wire [63°F rise] when installed in accordance with the manufacturer's instructions.

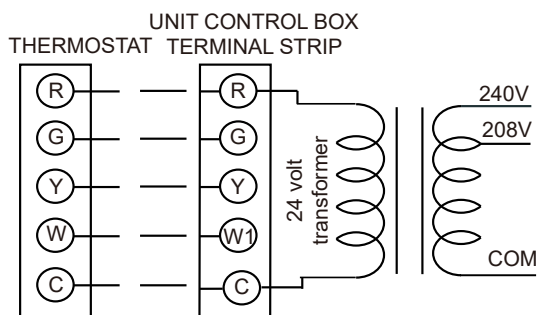

Fig. 5-1 Typical Field Control Wiring Diagram

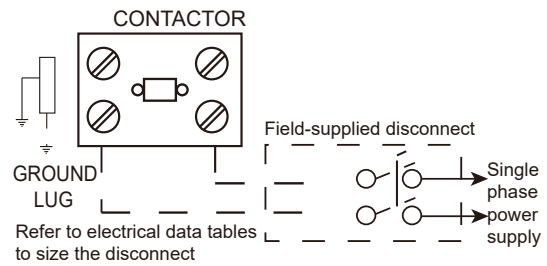

Fig. 5-2 Typical Field Power Wiring Diagram

## 5.3 Internal Wiring

**IMPORTANT:** Some single phase units are equipped with a single pole contactor. Caution must be exercised when servicing as only one leg of the power supply is broken with the contactor.

Some models are equipped with an electronically commutated blower motor which is constantly energized unless the main unit disconnect is in the off position.

A diagram of the internal wiring of this unit is located under the electrical box cover and in this manual. If any of the original wire as supplied with the appliance must be replaced, the wire gauge and insulation must be the same as the original wiring.

Transformer is factory wired for 230 volt on 208/230 volt models and must be changed to 208 volt applications. See unit wiring diagram for 208 volt wiring.

## 5.4 Thermostat

The room thermostat must be specifically designed to control package gas electric units.

# 6 FURNACE SECTION CONTROLS AND IGNITION SYSTEM

## 6.1 Normal Furnace Operating Sequence

This unit is equipped with an integrated direct spark ignition control.

1. The thermostat calls for gas heat.
2. The control board will run a self check to verify that the limit control and manual reset overtemperature control are closed and that the pressure switch is open. If so, the induced draft blower (inducer) begin a prepurge cycle.
3. The air proving negative pressure switch closes.
4. 15 seconds after the pressure switch closes, the gas valve opens and the spark is initiated for a 7 second trial for ignition.
5. Burners ignite and flame sensor proves all burners have lit.
6. The circulating air blower is energized after 45 seconds.
7. The control board enters a normal operation loop in which all safetycontrols are monitored continuously.
8. Thermostat is satisfied and opens.

9. The gas valve is de-energized and closes, shutting down the burner flame.
10. The control board will de-energize the inducer after a five second post purge.
11. The circulating air blower BLOWER-LOW is de-energized after max. 90 seconds.
  - The integrated control board has a three times ignition system.
  - After a total of 3 trials for ignition without sensing main burner flame, the system goes into lockout mode.
  - After 1 hour, the ignition control repeats the prepurge and ignition cycles for 3 tries and then goes into lockout mode again.
  - It continues this sequence of cycles and lockout each hour until ignition is successful or power is interrupted.
  - During the lockout mode, neither the spark ignition control or gas valve will be energized until the system is reset by turning the thermostat to the "OFF" position or interrupting the electrical power to the unit for 3 seconds or longer.
  - The induced draft blower and main burner will shut off when the thermostat is satisfied.
  - The circulating air blower will start and run on the heating speed if the thermostat fan switch is in the "ON" position.

The integrated furnace control is equipped with diagnostic LED. The LED is lit continuously when there is power to the control without a call for heat. If the LED is not lit, there is either no power to the control or there is an internal component failure within the control, and the control should be replaced.

If the control detects the following failures, the LED will flash for designated failure detections.

- 2 Flash: Failed to detect or sustain flame, system locked out.
- 3 Flash: Pressure switch or induced draft blower problem detected.
- 4 Flash: High limit or auxiliary limit open.
- 5 Flash: Flame sensed and gas valve not energized or flame sensed with no "W" signal.
- 6 Flash: Overtemperature switch open.
- 7 Flash: Thermostat miswired; W1 and W2 swapped.  
Slow flash rate: Normal, call for heat.

## 6.2 Operating Instructions

This appliance is equipped with a direct spark intermittent ignition device. This device lights the main burners each time the room thermostat (closes) calls for gas heat. See operating instructions on the back of the furnace/controls access panel.

### WARNING

Do not attempt to manually light this furnace with a match or any open flame. Attempting to do so can cause an explosion or fire resulting in property damage, personal injury or death.

## 6.3 To Start The Furnace

1. Set the thermostat to its lowest setting.
2. Turn off all electric power to the appliance.
3. This appliance does not have a pilot. It is equipped with an ignition device which automatically lights the burner. Do not try to light the burner by hand.

4. Remove control door.
5. Turn the gas valve to the "OFF" position.
6. Wait five (5) minutes to clear out any gas. Then smell for gas, including near the floor. If you smell gas, STOP! Follow B in the safety information on the Operating Instructions located on the back of the controls/access panel. If you don't smell gas, go to the next step.
7. Turn the gas valve to the "ON" position.
8. Replace the control door.
9. Turn on all electric power to the appliance.
10. Set the thermostat to the desired setting.
11. If the appliance will not operate, follow the instructions below to shut down the furnace.

### WARNING

The spark ignitor and ignition lead from the ignition control are high voltage. Keep hands or tools away to prevent electrical shock. Shut off electrical power before servicing any of the controls. Failure to adhere to this warning can result in personal injury or death.

The initial start-up on a new installation may require the control system to be energized in some time until any air has bled through the system and fuel gas is available at the burners.

## 6.4 To Shut Down Furnace

1. Set the thermostat to the lowest setting.
2. Turn off all electric power to the appliance if service is to be performed.
3. Remove control door.
4. Move gas valve to the "OFF" position.
5. Replace control door.

### WARNING

Should overheating occur or the gas supply fail to shut off. Shut off the Manual Gas valve to the appliance before shutting off the electrical supply. Failure to do so can result in an explosion or fire causing property damage, severe personal injury or death.

## 6.5 Burners

Burners for these units have been designed so that field adjustment is not required. Burners are tray-mounted and accessible for easy cleaning when required.

## 6.6 Manual Reset Overtemperature Control

A manual reset overtemperature control is located on the burner shield. This device senses blockage in the heat exchanger or insufficient combustion air. This shuts off the main burners if excessive temperatures occur in the burner compartment.

Operation of this control indicates an abnormal condition. Therefore, the unit should be examined by a qualified installer, service agency, or the gas supplier before being placed back into operation.

## WARNING

DO NOT JUMPER THIS DEVICE! Do not reset the overtemperature control without taking corrective action to assure that an adequate supply of combustion air is maintained under all conditions of operation. Failure to do so can result in Carbon Monoxide poisoning or death. Replace this control only with the identical replacement part.

### 6.7 Pressure Switch

This furnace has a negative pressure switch for sensing a blocked exhaust or a failed induced draft blower. It is normally closed when the induced draft blower starts, indicating air flow through the combustion chamber.

### 6.8 Limit Control

The supply air high temperature limit cut-off is set at the factory and cannot be adjusted. It is calibrated to prevent the air temperature leaving the furnace from exceeding the maximum outlet air temperature. **WARNING: DO NOT JUMPER THIS DEVICE! Replace this control only with the identical replacement part.**

## 7 SYSTEM OPERATING INFORMATION

### 7.1 Advise the Customer

1. Keep the air filters clean. The heating system operates better, more efficiently and more economically.
2. Arrange the furniture and drapes so that the supply air registers and the return air grilles are unobstructed.
3. Close doors and windows. This reduces the heating load on the system.
4. Avoid excessive use of exhaust fans.
5. Do not permit the heat generated by television, lamps or radios to influence the thermostat operation.
6. Except for the mounting platform, keep all combustible articles three feet from the unit and exhaust system.
7. **IMPORTANT:** Replace all blower doors and compartment after servicing the unit. Do not operate the unit without all panels and doors securely in place.
8. Do not allow snow or other debris to accumulate in the vicinity of the appliance.

### 7.2 Furnace Section Maintenance

The unit's furnace should operate for many years without excessive scale build-up in flue passageways; and it should have a qualified installer, service agency, or gas supplier annually inspect the flue passageways, the exhaust system and the burners for continued safe operation, paying particular attention to deterioration from corrosion or other sources.

If during inspection the flue passageways and exhaust system are determined to require cleaning, the following procedures should be followed (by a qualified installer, service agency, or gas supplier):

1. Turn off the electrical power to the unit and set the thermostat to the lowest temperature.
2. Shut off the gas supply to the unit either at the meter or at manual valve in the supply piping.

## WARNING

Label all wires prior to disconnection when servicing controls.

Wiring errors can cause improper and dangerous operation resulting in fire, electrical shock, property damage, personal injury or death.

3. Remove the furnace controls access panel and the control box cover.
4. Disconnect the gas supply piping from the gas valve.
5. Disconnect the wiring to the induced draft blower motor, gas valve, flame sensor, and flame roll-out control, and igniter cable. Mark all wires disconnected for proper reconnection.
6. Remove the screws (4) connecting the burner tray to the heat exchanger mounting panel.
7. Remove the burner tray and the manifold assembly from the unit.
8. Remove the screws (4) connecting the induced draft blower to the collector box and screws (16) connecting the collector box to the heat exchanger mounting panel. Remove the induced draft blower and the collector box from the unit.
9. Remove the turbulators from inside the heat exchangers by inserting the blade of a screwdriver under the locking tabs. Pop the tabs out of the expanded grooves of the heat exchanger. Slide the turbulators out of the heat exchangers.
10. Direct a water hose into the outlet of the heat exchanger top. Flush the inside of each heat exchanger tube with water. Blow out each tube with air to remove excessive moisture.
11. Reassemble (steps 1 through 10 in reverse order). **Be careful not to strip out the screw holes used to mount the collector box and inducer blower. Replace inducer blower gasket and collector box gasket with factory replacements if damaged.**

## WARNING

Holes in the exhaust transition or heat exchanger can cause toxic fumes to enter the home. The exhaust transition or heat exchanger must be replaced if they have holes or cracks in them.

Failure to do so can cause Carbon Monoxide poisoning resulting in personal injury or death.

The manufacturer recommends that a qualified installer, service agency or the gas supplier visually inspect the burner flames for the desired flame appearance at the beginning of the heating season and approximately midway in heating season.

The manufacturer also recommends that a qualified installer, service agency or the gas supplier clean the flame sensor with steel wool at the beginning of the heating season.

## WARNING

Disconnect main electrical power to the unit before attempting maintenance. Failure to do so may result in electrical shock or severe personal injury or death.

### 7.3 Lubrication

**IMPORTANT:** DO NOT attempt to lubricate the bearings on the blower motor or the induced draft blower motor. Addition of lubricants can reduce the motor life and void the warranty.

The blower motor and induced draft blower motor are prelubricated by the manufacturer and do not require further attention.

A qualified installer, service agency or the gas supplier must periodically clean the motors to prevent the possibility of overheating due to an accumulation of dust and dirt on the windings or on the motor exterior. And, as suggested elsewhere in these instructions, the air filters should be kept clean because dirty filters can restrict air flow and the motor depends upon sufficient air flowing across and through it to prevent overheating.

### 7.4 Cooling Section Maintenance

It is recommended that at the beginning of each cooling season a qualified installer or service agency inspect and clean the cooling section of this unit. The following areas should be addressed: evaporator coil, condenser coil, condenser fan motor and venturi area.

#### To inspect the evaporator coil:

1. Remove the filter access panel and the blower/evaporator coil access panel.

## WARNING

Label all wires prior to disconnection when servicing controls. Wiring errors can cause improper and dangerous operation resulting in fire, electrical shock, property damage, personal injury or death.

2. Unplug the wires from the circulating air blower and the limit control.  
Remove the two screws and slide the blower out of the unit sideways.
3. Shine a flashlight on the evaporator coil (both sides) and inspect for accumulation of lint, insulation, etc.
4. If coil requires cleaning, follow the steps shown below.

#### Cleaning Condenser Coil

1. Remove screws from condenser fan grille assembly and lay grille over on the unit top panel.
2. Remove the controls access panel and the control box cover.
3. Disconnect the outdoor fan motor wiring from the compressor contactor and capacitor. Remove the strain relief in the bulkhead and pull the fan motor wires through. Set grille assembly to the side.
4. Remove the screws that secure the unit top to the unit. Remove the top and set the unit top to the side.

5. The coil should be cleaned when it is dry. If the coil is coated with dirt or lint, vacuum it with a soft brush attachment. Be careful not to bend the coil fins.
6. The recommended cleaning method for microchannel condenser coils is pressurized water or air with an on-pinpoint nozzle and an ECU of at least 180 with pressure no greater than 600psi. To minimize the risk of coil damage, approach the cleaning of the coil with the pressure washer aimed perpendicular to the face of the coil during cleaning. Optimum clearance between the sprayer nozzle and the microchannel coil is 1"–3".

#### Cleaning Evaporator Coil, Drain Pan, Condensate Drain, Condenser Fan, Circulation Air Blower and Venturi

1. Remove the screws from the filter access panel and the blower/evaporator coil access panel from the unit. Remove the filter access panel and the blower/evaporator coil access panel.
2. The coil should be cleaned when it is dry. If the coil is coated with dirt or lint, vacuum it with a soft brush attachment. Be careful not to bend the coil fins.
3. If the coil is coated with oil or grease, clean it with a mild detergent-and-water solution. Rinse the coil thoroughly with water.  
**IMPORTANT:** Do not use excessive water pressure. Excessive water pressure can bend the fins and tubing of the coil and lead to inadequate unit performance. Be careful not to splash water excessively into unit.
4. Inspect the drain pan and condensate drain at the same time the evaporator coil is checked. Clean the drain pan by flushing with water and removing any matters of obstructions which may be present.
5. Flush the drain tube with water. If the drain tube is blocked, it can usually be cleared with high pressure water.
6. The venturi should also be inspected for items of obstruction such as collections of grass, dirt or spider webs. Remove any that are present.
7. Inspect the circulating air blower wheel and motor for accumulation of lint, dirt or other obstruction and clean if necessary. Inspect the blower motor mounts and the blower housing for loose mounts or other damage. Repair or replace if necessary.

#### Re-assembly

1. Place the condenser coil protective grille back on unit and replace all screws.
2. Place top panel back on unit and replace all screws.
3. Set condenser fan grille assembly on top of the unit with the fan on top and the motor wires on the venturi side. Run the fan motor wires through the bulkhead and pull wires through the hole on the bottom of the control box on the left side and into the control box. Reconnect fan motor wires per the wiring diagram attached to the back of the control box cover.
4. Replace wire strain relief in bulkhead after the slack is pulled out of the wires on the fan side. This will assure wires will not be damaged by the fan during unit operation.
5. Turn the condenser fan grille assembly over and into the recess in the unit top. Secure the grille to the unit with the four long #8 screws removed earlier.
6. Replace the circulating air blower, making sure that all wires are properly reconnected per the unit wiring diagram.
7. Replace the filter and blower/evaporator coil access panels.
8. Replace the control box cover and controls access panel.
9. Restore electrical power to the unit and check for proper operation, especially the condenser fan motor.

## 7.5 Replacement Parts

Contact your local distributor for a complete parts list.

## 7.6 Wiring Diagrams

Refer to the appropriate wiring diagram included in this manual.

## 7.7 Charging

Refer to the appropriate charge chart included in this manual.

## 7.8 Blower Motor Speed Taps

After determining necessary CFM and speed tap data, follow the steps below to change speeds.

1. Remove control door.
2. Please refer to the Table 10-1 & Table 10-2 and wiring diagram for the proper location of the wire on the speed tap block of the indoor blower motor to obtain the speed you have chosen.
3. After adjusting the wires accordingly, replace control door.

## 8 OPERATION

Most single phase units are equipped with Permanent Split Capacitor (PSC) motors (no start relay or start capacitor). It is important that such systems be off for a minimum of 5 minutes before restarting to allow equalization of pressures. Do not move the thermostat to cycle unit without waiting five minutes. To do so may cause the compressor to stop on an automatic open overload device or blow a fuse. Poor electrical service can cause nuisance tripping in overloads or blow fuses.

**IMPORTANT:** The compressor has an internal overload protector. Under some conditions, it can take up to 2 hours for this overload to reset. Make sure overload has had time to reset before condensing the compressor. The control allows the blower to operate for up to 90 seconds after the thermostat is satisfied.

## 8.1 Control System Operation

### 1. Heating mode

The wall thermostat "calls for heat," closing the R--to--W circuit. The furnace control performs a "NORMAL FURNACE OPERATING SEQUENCE".

### 2. Cooling mode

In the cooling mode, The thermostat closes the R--to--G--and--Y circuits. The thermostat will energize the compressor contactor and the indoor blower relay. the blower motor will operate on BLOWER-SINGLE/Hi speed , After the thermostat is satisfied, the compressor is de-energized and the cool mode delay-to-fan-off period begins. After the delay-to-fan- off period ends, the circulator fan is de-energized. The indoor blower can be operated continuously by setting the thermostat fan switch at the "ON" position.

### 3. Fan mode

When the circuit R--to--G is closed by the thermostat, the blower motor will operate on BLOWER-LOW speed , If the thermostat fan switch is moved to the ON position, the circulator fan will be energized. When the fan switch is returned to the AUTO position, the circulator fan will be de-energized.

## 8.2 Fan Delay Adjustment

As shipped, the circulator blower fan will remain on for 90 seconds after the gas valve closes. When a call for cooling occurs, the circulator fan comes on and remains on for 80 seconds after the call for cooling ends. During normal heating operation, the circulator fan will come on approximately 45 seconds after the gas valve opens.

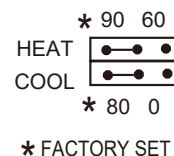



## 9 PHYSICAL DATA

Table 9-1: 13.4 SEER2 Physical Data

Component	Models			
	J4PG4024E1060AA	J4PG4030E1060AA	J4PG4036E1090AA	J4PG4042E1090AA
Nominal Tonnage	2.0	2.5	3.0	3.5
<b>ARI COOLING PERFORMANCE</b>				
ARI net capacity (Btu)	22800	28400	34200	40000
EER2	10.6	10.6	10.6	10.6
SEER2	13.4	13.4	13.4	13.4
Nominal CFM	720	940	1050	1200
System power (kW)	2.15	2.68	3.30	3.77
Refrigerant type	R410a	R410a	R410a	R410a
Refrigerant charge (lb-oz)	3-0	3-5	3-5	4-7
<b>GAS HEATING PERFORMANCE</b>				
Heating input (Btu)	60000	60000	90000	90000
Heating output (Btu)	48000	48000	72000	72000
Temperature rise range (F)	30-60	30-60	40-70	35-65
AFUE (%)	81	81	81	81
Steady state efficiency (%)	81	81	81	81
No. burners	5	5	7	7
No. stages	1	1	1	1
Gas connection pipe size (in.)	1/2" NPT	1/2" NPT	1/2" NPT	1/2" NPT
<b>DIMENSIONS (Inches)</b>				
Length	50-11/16	50-11/16	50-11/16	50-11/16
Width	35-1/16	35-1/16	35-1/16	35-1/16
Height	46-13/16	46-13/16	46-13/16	46-13/16
OPERATING WT. (lbs)	428	437	443	474
<b>COMPRESSORS</b>				
Type	Rotate	Rotate	Rotate	Scroll
Quantity	1	1	1	1
<b>CONDENSER COIL DATA</b>				
Type	Microchannel	Microchannel	Microchannel	Microchannel
Coil Width (in.)	0.63	0.63	0.63	0.63
Face Area (sq. ft.)	14.11	14.11	14.11	14.11
Rows	1+1	1+1	1+1	1+1
FPI	23	23	23	23
<b>EVAPORATOR COIL DATA</b>				
Face area (Sq. Ft)	3.96	3.96	3.96	3.96
Rows	4	4	4	4
Fins per inch	17	17	17	17
Tube diameter	9/32	9/32	9/32	9/32
Circuitry type	interlaced	interlaced	interlaced	interlaced
Refrigerant control	Orifice	Orifice	Orifice	Orifice
<b>CONDENSER FAN DATA</b>				
Fan diameter (inch)	23-5/8	23-5/8	23-5/8	23-5/8
Type	Prop	Prop	Prop	Prop
Drive type	Direct	Direct	Direct	Direct
No. speeds	1	1	1	1
Number of motors	1	1	1	1
Motor HP each	1/12 (60W)	1/6 (110W)	1/6 (110W)	1/3 (290W)
RPM	840	840	840	840
Nominal total CFM	2970	2770	2970	2770
<b>DIRECT DRIVE EVAP FAN DATA</b>				
Quantity	1	1	1	1
Fan Size (Inch)	10×10	10×10	10×10	10×10
Type	Centrifugal	Centrifugal	Centrifugal	Centrifugal
No. speeds	1	1	1	1
Motor HP each	1/2 (375W)	1/2 (375W)	1/2 (375W)	3/4 (560W)

Table 9-1: 13.4 SEER2 Physical Data

Component	Models		
	J4PG4048E1090AA	J4PG4060E1090AA	J4PG4060E1110AA
Nominal Tonnage	4.0	5.0	5.0
<b>ARI COOLING PERFORMANCE</b>			
ARI net capacity (Btu)	48000	57500	57500
EER2	10.6	10.6	10.6
SEER2	13.4	13.4	13.4
Nominal CFM	1650	1850	1850
System power (kW)	4.53	5.42	5.42
Refrigerant type	R410a	R410a	R410a
Refrigerant charge (lb-oz)	4-8	4-10	4-10
<b>GAS HEATING PERFORMANCE</b>			
Heating input (Btu)	90000	90000	110000
Heating output (Btu)	72000	72000	88000
Temperature rise range (F)	30-60	30-60	30-60
AFUE (%)	81	81	81
Steady state efficiency (%)	81	81	8
No. burners	6	6	7
No. stages	1	1	1
Gas connection pipe size (in.)	1/2" NPT	1/2" NPT	1/2" NPT
<b>DIMENSIONS (Inches)</b>			
Length	51-9/16	51-9/16	51-9/16
Width	44-13/16	44-13/16	44-13/16
Height	51-7/16	51-7/16	51-7/16
OPERATING WT. (lbs)	556	556	560
<b>COMPRESSORS</b>			
Type	Scroll	Scroll	Scroll
Quantity	1	1	1
<b>CONDENSER COIL DATA</b>			
Type	Microchannel	Microchannel	Microchannel
Coil Width (in.)	0.63	0.63	0.63
Face Area (sq. ft.)	20.17	20.17	20.17
Rows	1+1	1+1	1+1
FPI	23	23	23
<b>EVAPORATOR COIL DATA</b>			
Face area (Sq. Ft)	6.1	6.1	6.1
Rows	4	4	4
Fins per inch	17	17	17
Tube diameter	9/32	9/32	9/32
Circuitry type	interlaced	interlaced	interlaced
Refrigerant control	Orifice	Orifice	Orifice
<b>CONDENSER FAN DATA</b>			
Fan diameter (inch)	26-3/8	26-3/8	26-3/8
Type	Prop	Prop	Prop
Drive type	Direct	Direct	Direct
No. speeds	1	1	1
Number of motors	1	1	1
Motor HP each	1/3 (290W)	1/3 (290W)	1/3 (290W)
RPM	1070	1070	1070
Nominal total CFM	5170	5170	5170
<b>DIRECT DRIVE EVAP FAN DATA</b>			
Quantity	1	1	1
Fan Size (Inch)	11×10-5/8	11×10-5/8	11×10-5/8
Type	Centrifugal	Centrifugal	Centrifugal
No. speeds	1	1	1
Motor HP each	3/4 (560W)	3/4 (560W)	3/4 (560W)

# 10 AIRFLOW PERFORMANCE

Airflow performance data is based on cooling performance with a coil and no filter in place. Use this performance table for appropriate unit size, external static applied to unit and allow operation within the minimum and maximum limits shown in table below for both cooling and electric heat operation.

Table 10-1 Indoor Airflow Performance - 230 Volts

Model Number	Motor Speed		External Static Pressure-Inches W.C.[kPa]										
			0[0]	0.1[.02]	0.2[.05]	0.3[.07]	0.4[.10]	0.5[.12]	0.6[.15]	0.7[.17]	0.8[.20]	0.9[.23]	1.0[.25]
24	Low (Tap1)	CFM	/	855	792	727	669	/	/	/	/	/	/
		Current/A	/	1.39	1.44	1.46	1.5	/	/	/	/	/	/
		Power/W	/	140	146	147	152	/	/	/	/	/	/
	Middle-1 (Tap2)	CFM	/	/	/	/	827	771	689	621	568	/	/
		Current/A	/	/	/	/	1.94	2.00	2.05	2.08	2.11	/	/
		Power/W	/	/	/	/	212	221	225	230	234	/	/
	Middle-2 (Tap3)	CFM	/	/	/	/	/	/	/	846	774	710	660
		Current/A	/	/	/	/	/	/	/	2.72	2.73	2.82	2.86
		Power/W	/	/	/	/	/	/	/	317	312	330	335
	Middle-3 (Tap4)	CFM	/	/	/	/	/	/	/	/	/	844	797
		Current/A	/	/	/	/	/	/	/	/	/	3.24	3.28
		Power/W	/	/	/	/	/	/	/	/	/	385	391
30	Low (Tap1)	CFM	917	855	792	/	/	/	/	/	/	/	/
		Current/A	1.37	1.39	1.44	/	/	/	/	/	/	/	/
		Power/W	137	140	146	/	/	/	/	/	/	/	/
	Middle-1 (Tap2)	CFM	1051	997	940	885	827	771	/	/	/	/	/
		Current/A	1.78	1.81	1.86	1.88	1.94	2	/	/	/	/	/
		Power/W	191	196	201	201	212	221	/	/	/	/	/
	Middle-2 (Tap3)	CFM	/	/	/	1049	995	947	898	846	774	710	/
		Current/A	/	/	/	2.51	2.57	2.60	2.67	2.72	2.73	2.82	/
		Power/W	/	/	/	288	297	299	311	317	312	330	/
	Middle-3 (Tap4)	CFM	/	/	/	/	/	1045	997	951	908	844	797
		Current/A	/	/	/	/	/	3.03	3.04	3.13	3.18	3.24	3.28
		Power/W	/	/	/	/	/	359	354	371	378	385	391
	High (Tap5)	CFM	/	/	/	/	/	/	/	/	/	1032	991
		Current/A	/	/	/	/	/	/	/	/	/	4.03	3.98
		Power/W	/	/	/	/	/	/	/	/	/	495	482
36	Low (Tap1)	CFM	917	855	/	/	/	/	/	/	/	/	/
		Current/A	1.37	1.39	/	/	/	/	/	/	/	/	/
		Power/W	137	140	/	/	/	/	/	/	/	/	/
	Middle-1 (Tap2)	CFM	1051	997	940	885	/	/	/	/	/	/	/
		Current/A	1.78	1.81	1.86	1.88	/	/	/	/	/	/	/
		Power/W	191	196	201	201	/	/	/	/	/	/	/
	Middle-2 (Tap3)	CFM	1204	1153	1100	1049	995	947	898	/	/	/	/
		Current/A	2.4	2.45	2.44	2.51	2.57	2.60	2.67	/	/	/	/
		Power/W	275	282	276	288	297	299	311	/	/	/	/
	Middle-3 (Tap4)	CFM	1281	1240	1190	1142	1092	1045	997	951	908	/	/
		Current/A	2.82	2.84	2.85	2.96	3	3.03	3.04	3.13	3.18	/	/
		Power/W	331	333	330	350	357	359	354	371	378	/	/
	High (Tap5)	CFM	/	/	/	/	1280	1244	1194	1140	1083	1032	991
		Current/A	/	/	/	/	3.95	4.08	4.07	4.00	4.06	4.03	3.98
		Power/W	/	/	/	/	481	507	504	486	502	495	482

Table 10-1 Indoor Airflow Performance - 230 Volts

Model Number	Motor Speed		External Static Pressure-Inches W.C.[kPa]										
			0[0]	0.1[.02]	0.2[.05]	0.3[.07]	0.4[.10]	0.5[.12]	0.6[.15]	0.7[.17]	0.8[.20]	0.9[.23]	1.0[.25]
42	Middle-1 (Tap2)	CFM	1153	1102	1056	/	/	/	/	/	/	/	/
		Current/A	2.09	2.13	2.18	/	/	/	/	/	/	/	/
		Power/W	227	233	239	/	/	/	/	/	/	/	/
	Middle-2 (Tap3)	CFM	/	1388	1343	1306	1267	1229	1192	1156	1093	1066	1012
		Current/A	/	3.53	3.55	3.66	3.71	3.77	3.84	3.88	3.92	3.91	3.83
		Power/W	/	422	418	438	445	453	463	468	473	472	455
	Middle-3 (Tap4)	CFM	/	/	/	/	/	/	1387	1354	1309	1231	1168
		Current/A	/	/	/	/	/	/	5.09	5.13	5.12	4.90	4.73
		Power/W	/	/	/	/	/	/	633	639	638	606	583
	High (Tap5)	CFM	/	/	/	/	/	/	/	/	1321	1251	1167
		Current/A	/	/	/	/	/	/	/	/	5.19	4.90	4.60
		Power/W	/	/	/	/	/	/	/	/	640	595	586
48	Middle-1 (Tap2)	CFM	1251	/	/	/	/	/	/	/	/	/	/
		Current/A	1.67	/	/	/	/	/	/	/	/	/	/
		Power/W	192	/	/	/	/	/	/	/	/	/	/
	Middle-2 (Tap3)	CFM	1547	1473	1424	1374	1323	1267	1213	/	/	/	/
		Current/A	2.8	2.87	2.95	3.04	3.12	3.21	3.3	/	/	/	/
		Power/W	340	350	360	371	382	394	407	/	/	/	/
	Middle-3 (Tap4)	CFM	1789	1741	1695	1649	1605	1559	1510	1460	1409	1359	1313
		Current/A	4.11	4.19	4.28	4.36	4.45	4.54	4.64	4.74	4.83	4.92	5
		Power/W	517	528	540	551	564	576	589	603	615	627	639
	High (Tap5)	CFM	/	/	/	/	/	1755	1696	1630	1563	1490	1438
		Current/A	/	/	/	/	/	5.79	5.76	5.73	5.71	5.68	5.66
		Power/W	/	/	/	/	/	750	745	741	737	733	730
60	Middle-2 (Tap3)	CFM	1547	1473	/	/	/	/	/	/	/	/	/
		Current/A	2.8	2.87	/	/	/	/	/	/	/	/	/
		Power/W	340	350	/	/	/	/	/	/	/	/	/
	Middle-3 (Tap4)	CFM	1789	1741	1695	1649	1605	1559	1510	1460	/	/	/
		Current/A	4.11	4.19	4.28	4.36	4.45	4.54	4.64	4.74	/	/	/
		Power/W	517	528	540	551	564	576	589	603	/	/	/
	High (Tap5)	CFM	2035	1976	1927	1875	1815	1755	1696	1630	1563	1490	1438
		Current/A	5.66	5.74	5.81	5.85	5.82	5.79	5.76	5.73	5.71	5.68	5.66
		Power/W	733	744	754	758	754	750	745	741	737	733	730

\* The above airflow data for reference only.

Table 10-2 Motor Speed from factory

Model	Cooling		Gas Heat		Blower Size	Motor HP	Temperature rise range(°F)
	Usable Motor Speed	Motor Speed from factory	Usable Motor Speed	Motor Speed from factory			
J4PG4024E1060AA	low	Middle-1	low	Middle-1	10×10	1/2	30-60
	Middle-1		Middle-1				
	Middle-2		Middle-2				
	Middle-3		Middle-3				
J4PG4030E1060AA	low	Middle-2	low	Middle-1	10×10	1/2	30-60
	Middle-1		Middle-1				
	Middle-2		Middle-2				
	Middle-3		Middle-3				
J4PG4036E1090AA	low	Middle-3	low	Middle-3	10×10	1/2	40-70
	Middle-1		Middle-1				
	Middle-2		Middle-2				
	Middle-3		Middle-3				
J4PG4042E1090AA	High	Middle-2	High	Middle-2	10×10	3/4	35-65
	Middle-1		Middle-1				
	Middle-2		Middle-2				
	Middle-3		Middle-3				
J4PG4048E1090AA	High	Middle-3	High	Middle-2	11 ×10-5/8	3/4	30-60
	Middle-1		Middle-1				
	Middle-2		Middle-2				
	Middle-3		Middle-3				
J4PG4060E1090AA	Middle-2	High	Middle-2	Middle-2	11×10-5/8	3/4	30-60
	Middle-3		Middle-3				
	High		High				
J4PG4060E1110AA	Middle-2	High	Middle-2	Middle-3	11×10-5/8	3/4	30-60
	Middle-3		Middle-3				
	High		High				

- The air distribution system has the greatest effect on airflow. The duct system is totally controlled by the contractor. For this reason, the contractor should use only industry-recognized procedures.
- Each ton of cooling requires between 350 and 450 cubic feet of air per minute (CFM), or 400 CFM nominally.
- Duct design and construction should be carefully done. System performance can be lowered dramatically through bad planning or workmanship.
- Air supply diffusers must be selected and located carefully. They must be sized and positioned to deliver treated air along the perimeter of the space. If they are too small for their intended airflow, they become noisy. If they are not located properly, they cause drafts. Return air grilles must be properly sized to carry air back to the blower. If they are too small, they also cause noise.
- The installers should balance the air distribution system to ensure proper quiet airflow to all rooms in the home. This ensures a comfortable living space.
- An air velocity meter or airflow hood can give a reading of system CFM.
- When installation, installer should select the air speed according to the actual setting static pressure. Please refer to the Table 10-1 & Table 10-2.

# 11 TROUBLE SHOOTING

## ⚠ WARNING

Components trouble shooting requires opening control box with power on. Use extreme care while working on this condition.  
Check nameplate and this instruction when making wire connections.

Table 11-1 Trouble shooting chart

SYMPTOM	POSSIBLE CAUSE	REMEDY
Unit will not run	Power off or loose electrical connection	Check for correct voltage at compressor contactor in control box
	Thermostat out of calibration-set too high	Reset
	Failed contactor	Check for 24 volts at contactor coil - replace if contacts are open
	Blown fuses	Replace fuses
	Transformer defective	Check wiring - replace transformer
	Interconnecting low voltage wiring damaged	Replace thermostat wiring
Condenser fan runs, compressor doesn't	Run or start capacitor failed (single phase only)	Replace
	Loose connection	Check for correct voltage at compressor - check & tighten all connection
	Compressor stuck, grounded or open motor winding open internal overload	Wait at least 2 hours for overload to reset. If still open, replace the compressor.
	Low voltage condition	Determine cause and correct. At compressor terminals, voltages must be within 10% of rating plate volts when unit is operating.
Insufficient cooling	Improperly sized unit	Recalculate load
	Improper airflow	Check - should be approximately 400 CFM per ton.
	Incorrect refrigerant charge	Charge per procedure attached to unit service panel.
	Air, non-condensable or moisture in system	Recover refrigerant, evacuate & recharge, add filter drier
	Incorrect voltage	Determine cause and correct. At compressor terminals, voltages must be within 10% of rating plate volts when unit is operating.
Compressor short cycles	Incorrect voltage	At compressor terminals, voltage must be $\pm 10\%$ or nameplate marking when unit is operating.
	Defective overload protector	Replace - check for correct voltage
	Refrigerant undercharge	Add refrigerant

Table 11-1 Trouble shooting chart (Continued)

SYMPTOM	POSSIBLE CAUSE	REMEDY
Compressor operates continuously	Dirty air filter	Replace filter
	Unit undersized for load	Decrease load or increase unit size
	Thermostat temperature set too low	Reset thermostat
	Low refrigerant charge	Locate leak, repair, and recharge
	Air in system	Recover refrigerant, evacuate system, and recharge
Registers sweat	Outdoor coil dirty or restricted	Clean coil or remove restriction
	Low evaporator airflow	Increase speed of blower or reduce restriction - replace air filter
High head-low vapor pressure	Restriction in liquid line, expansion device or filter drier	Remove or replace defective component
	Flow check piston size too small	Change to correct size piston
	Incorrect capillary tubes	Change coil assembly
	TXV does not open	Replace TXV
High head-high or normal vapor pressure - Cooling mode	Dirty condenser coil	Clean coil
	Refrigerant overcharge	Correct system charge
	Condenser fan not running	Repair or replace
Low head-high vapor pressures	Air or non-condensable in system	Recover refrigerant, evacuate & recharge
	Defective compressor valves	Replace compressor
Low vapor - cool compressor - iced evaporator coil	Incorrect capillary tubes	Replace coil assembly
	Low evaporator airflow	Increase speed of blower or reduce restriction - replace air filter
	Operating below 65°F outdoors	Add Low Ambient Kit
High vapor pressure	Moisture in system	Recover refrigerant - evacuate & recharge - add filter drier
	Excessive load	Recheck load calculation
Fluctuating head & vapor pressure	Defective compressor	Replace
	TXV hunting	Check TXV bulb clamp - check air distribution on coil - replace TXV
Gurgle or pulsing noise at expansion device or liquid line	Air or non-condensable in system	Recover refrigerant - evacuate & recharge
	Air or non-condensable in system	Recover refrigerant - evacuate & recharge
Circulating air blower & inducer run continuously, compressor will not start	Manual reset overtemperature control tripped	Reset or replace
	Wire loose in limit circuit	Check wiring
Burners will not ignite	Water in gas line	Drain. Install drip leg.
	No power to furnace	Check power supply fuses, wiring or circuit breaker.
	No 24 volts power supply to control circuit	Check transformer.
	Miswired or loose connections	Check all wiring and wire nut connections
	Misaligned spark electrodes	Check flame ignition and sense electrode positioning. Adjust as necessary.
Inadequate heating	No gas at main burners	Check gas line for air. Purge as necessary. NOTE: After purging gas line of air, wait at least 5 minutes for any gas to dissipate before attempting to light unit. Check gas valve.
	Dirty air filter	Clean or replace filter as necessary
	Gas input to furnace too low	Check gas pressure at manifold with that on unit nameplate
	Unit undersized for application	Replace with proper unit or add additional unit
	Restricted airflow	Clean or replace filter, remove any restriction
Poor flame characteristics	Limit switch cycles main burners	Check rotation of blower, temperature rise of unit. Adjust as necessary
	Incomplete combustion results in: Aldehyde odors, carbon monoxide, sooting flame, floating flame	Tighten all screws around burner compartment Cracked heat exchanger. Replace as necessary. Unit over-fired. Reduce input (change orifices or adjust gas line or manifold pressure). Check burner alignment
		Inspect heat exchanger for blockage. Clean as necessary.
Both condenser fan and compressor startup and shutdown frequently (about three minutes per cycle)	Abnormal high discharge pressure caused the high pressure switch act	Reference to the remedy of 'High head-high or normal vapor pressure-cooling mode'.

High Altitude

Model	NUMBER OF BURNERS	NATURAL GAS				
		HEATING VALVE 1075Btu/Cu.Ft.				
		SPECIFIC GRAVITY 0.65/MANIFOLD PRESSURE @3.5"W.C.				
		ELEVATION 0-2000' (USA/CANADA)	ELEVATION 4000' (USA ONLY)	ELEVATION 6000' (USA ONLY)	ELEVATION 8000' (USA ONLY)	ELEVATION 2000-4500' (CANADA)
J4PG4024E1060AA	5	51	53	53	54	51
J4PG4030E1060AA	5	51	53	53	54	51
J4PG4036E1090AA	7	51	52	53	53	51
J4PG4042E1090AA	7	51	52	53	53	51
J4PG4048E1090AA	6	49	50	51	52	49
J4PG4060E1090AA	6	49	50	51	52	49
J4PG4060E1110AA	7	49	50	51	51	49

Model	NUMBER OF BURNERS	NATURAL GAS				
		HEATING VALVE 2500Btu/Cu.Ft.				
		SPECIFIC GRAVITY 0.65/MANIFOLD PRESSURE @10.0"W.C.				
		ELEVATION 0-2000' (USA/CANADA)	ELEVATION 4000' (USA ONLY)	ELEVATION 6000' (USA ONLY)	ELEVATION 8000' (USA ONLY)	ELEVATION 2000-4500' (CANADA)
J4PG4024E1060AA	5	59	63	64	64	59
J4PG4030E1060AA	5	59	63	64	64	59
J4PG4036E1090AA	7	59	62	63	64	59
J4PG4042E1090AA	7	59	62	63	64	59
J4PG4048E1090AA	6	56	59	60	61	56
J4PG4060E1090AA	6	56	59	60	61	56
J4PG4060E1110AA	7	56	58	59	60	56

For addressing derating at altitudes above 2000 ft. (610 m), the instructions shall indicate one of the following:

1. Installation of this furnace at altitudes above 2000 ft (610 m) shall be in accordance with local codes, or in the absence of local codes, the National Fuel Gas Code, ANSI Z223.1/NFPA 54 or National Standard of Canada, Natural Gas and Propane Installation Code, CSA B149.1.
2. For furnaces requiring modifications other than only gas orifice and/or manifold pressure adjustment for installation at high altitude, "Installation of this furnace at altitudes above 2000 ft (610 m) shall be made in accordance with the Listed High Altitude Conversion Kit available with this furnace."
3. For furnaces requiring only gas orifice and/or manifold pressure adjustment for installation at high altitude, the furnace installation instructions shall provide adequate details on proper adjustments for various altitudes.

Fuse Parameters

Model	Type	RATED VOLTAGE	RATED CURRENT	DIMENSIONS
50T	/	250Vac	3.15A	5.2×20mm
522	Time delay	250Vac	3.15A	5×20mm

**Indoor Fan replacement procedure**

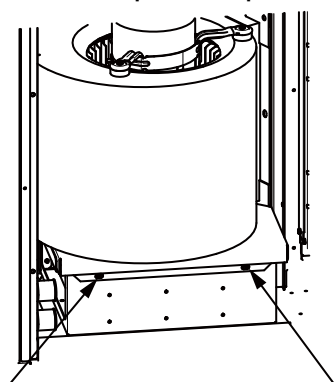

- Step1: Power off the unit and check to make sure motor is not operational.
- Step2: Unplug the power and signal wires from the motor.
- Step3: Use ascrewdriver to loosen the 2 bolts.
- Step4: Ensurethat there are no obstacles in the directionof blower housing asm extraction.
- Step5: Pull out the blower housing asm horizontally.
- Step6: Ensurethat there are no obstacles in the directionof blower housing asm insertion.
- Step7: New blower housing asm horizontally pushed in.
- Step8: Usea screwdriver to tightening the 2 bolts.
- Step9: Plugback the power and signal cables.
- Step10: Power onthe unit and check to make sure themotor is now operational.

# J4PG4024E1060AA

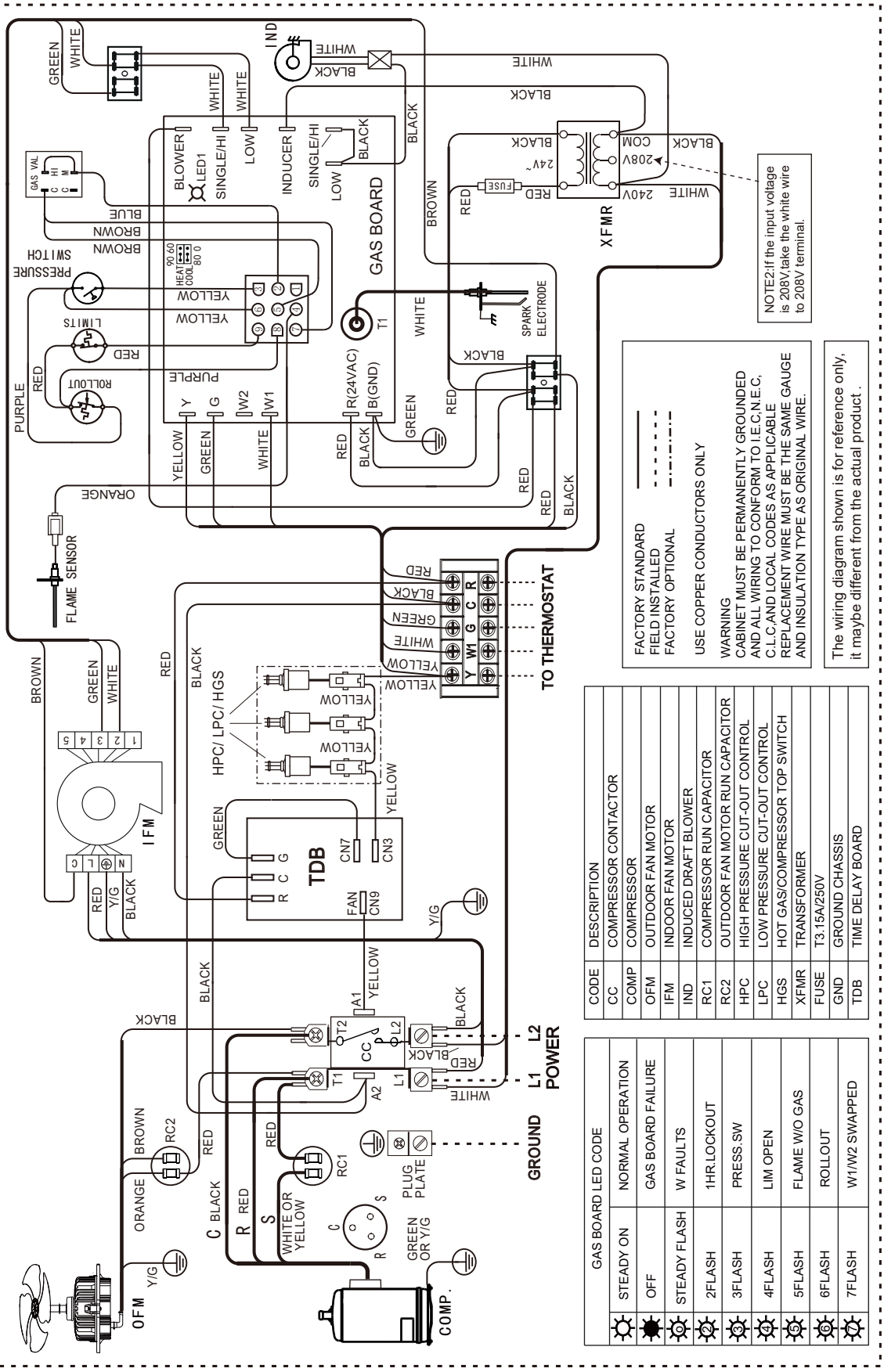

NOTE2: if the input voltage is 208V, take the white wire to 208V terminal.

--- FACTORY STANDARD  
 - - - - - FIELD INSTALLED  
 - · - · - · FACTORY OPTIONAL  
 - - - - - USE COPPER CONDUCTORS ONLY  
 WARNING  
 CABINET MUST BE PERMANENTLY GROUNDED  
 AND ALL WIRING TO CONFORM TO I.E.C. N.E.C.  
 C.L.C. AND LOCAL CODES AS APPLICABLE  
 REPLACEMENT WIRE MUST BE THE SAME GAUGE  
 AND INSULATION TYPE AS ORIGINAL WIRE.  
 The wiring diagram shown is for reference only,  
 it may be different from the actual product.

CODE	DESCRIPTION
CC	COMPRESSOR CONTACTOR
COMP	COMPRESSOR
OFM	OUTDOOR FAN MOTOR
IFM	INDOOR FAN MOTOR
IND	INDUCED DRAFT BLOWER
RC1	COMPRESSOR RUN CAPACITOR
RC2	OUTDOOR FAN MOTOR RUN CAPACITOR
HPC	HIGH PRESSURE CUT-OUT CONTROL
LPC	LOW PRESSURE CUT-OUT CONTROL
HGS	HOT GAS/COMPRESSOR TOP SWITCH
XFMR	TRANSFORMER
FUSE	T3.15A/250V
GND	GROUND CHASSIS
TDB	TIME DELAY BOARD

GAS BOARD LED CODE	DESCRIPTION
☀	STEADY ON
☀	NORMAL OPERATION
☀	OFF
☀	GAS BOARD FAILURE
☀	STEADY FLASH
☀	W FAULTS
☀	2FLASH
☀	1HR LOCKOUT
☀	3FLASH
☀	PRESS. SW
☀	4FLASH
☀	LIM OPEN
☀	5FLASH
☀	FLAME W/O GAS
☀	6FLASH
☀	ROLLOUT
☀	7FLASH
☀	W1/W2 SWAPPED

**J4PG4030E1060AA**

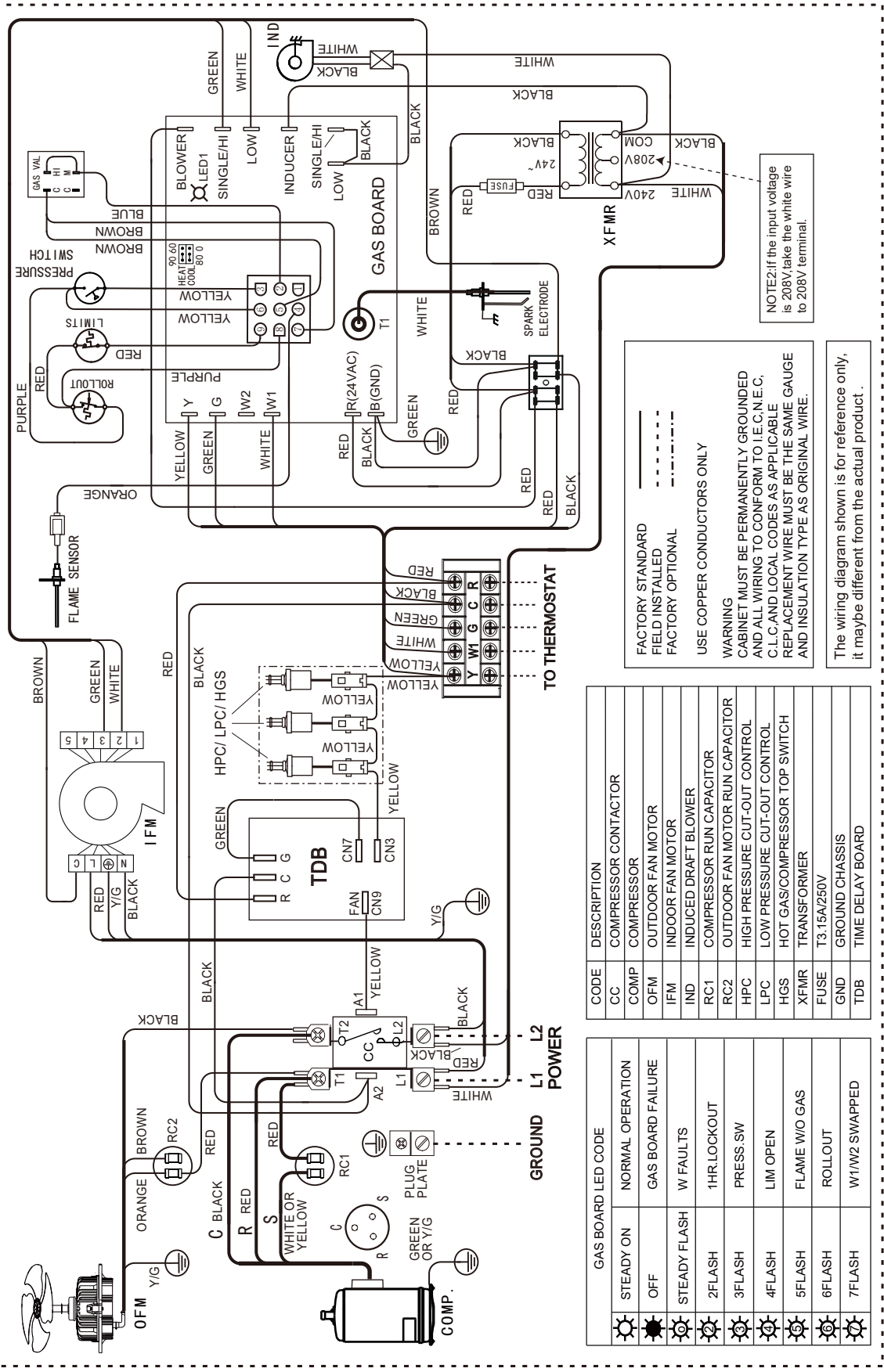

CODE	DESCRIPTION
CC	COMPRESSOR CONTACTOR
COMP	COMPRESSOR
OFM	OUTDOOR FAN MOTOR
IFM	INDOOR FAN MOTOR
IND	INDUCED DRAFT BLOWER
RC1	COMPRESSOR RUN CAPACITOR
RC2	OUTDOOR FAN MOTOR RUN CAPACITOR
HPC	HIGH PRESSURE CUT-OUT CONTROL
LPC	LOW PRESSURE CUT-OUT CONTROL
HGS	HOT GAS/COMPRESSOR TOP SWITCH
XFMR	TRANSFORMER
FUSE	T3.15A/250V
GND	GROUND CHASSIS
TDB	TIME DELAY BOARD

GAS BOARD LED CODE	DESCRIPTION
Steady On	NORMAL OPERATION
Off	GAS BOARD FAILURE
Steady Flash	W FAULTS
2 Flash	1HR LOCKOUT
3 Flash	PRESS. SW
4 Flash	LIM OPEN
5 Flash	FLAME W/O GAS
6 Flash	ROLLOUT
7 Flash	W1/W2 SWAPPED

# J4PG4036E1090AA

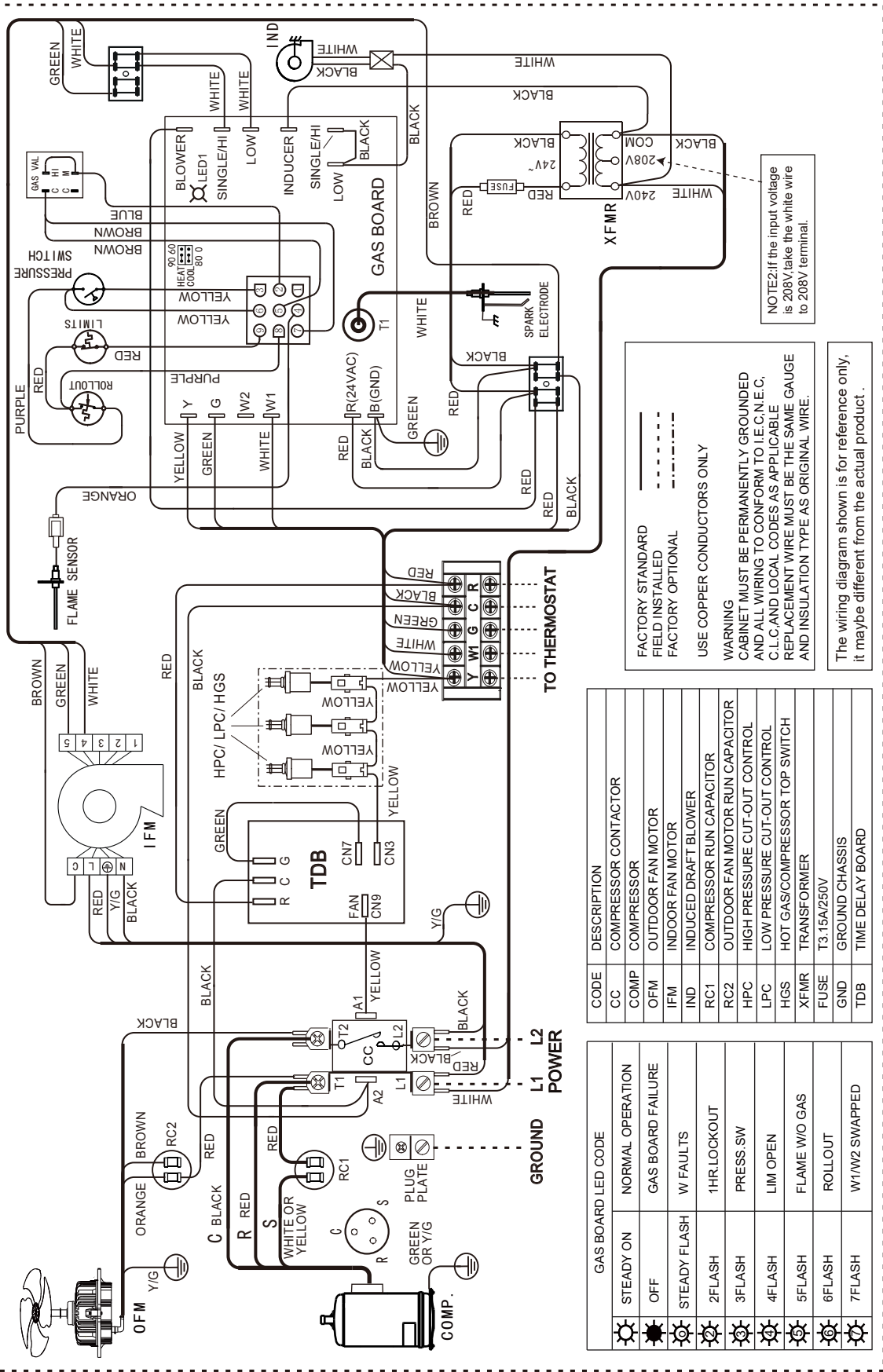

CODE	DESCRIPTION
CC	COMPRESSOR CONTACTOR
COMP	COMPRESSOR
OFM	OUTDOOR FAN MOTOR
IFM	INDOOR FAN MOTOR
IND	INDUCED DRAFT BLOWER
RC1	COMPRESSOR RUN CAPACITOR
RC2	OUTDOOR FAN MOTOR RUN CAPACITOR
HPC	HIGH PRESSURE CUT-OUT CONTROL
LPC	LOW PRESSURE CUT-OUT CONTROL
HGS	HOT GAS/COMPRESSOR TOP SWITCH
XFMR	TRANSFORMER
FUSE	T3.15A/250V
GND	GROUND CHASSIS
TDB	TIME DELAY BOARD

GAS BOARD LED CODE	DESCRIPTION
Steady On	NORMAL OPERATION
Off	GAS BOARD FAILURE
Steady Flash	W FAULTS
2 Flash	1HR LOCKOUT
3 Flash	PRESS. SW
4 Flash	LIM OPEN
5 Flash	FLAME W/O GAS
6 Flash	ROLL-OUT
7 Flash	W1/W2 SWAPPED

**J4PG4042E1090AA**

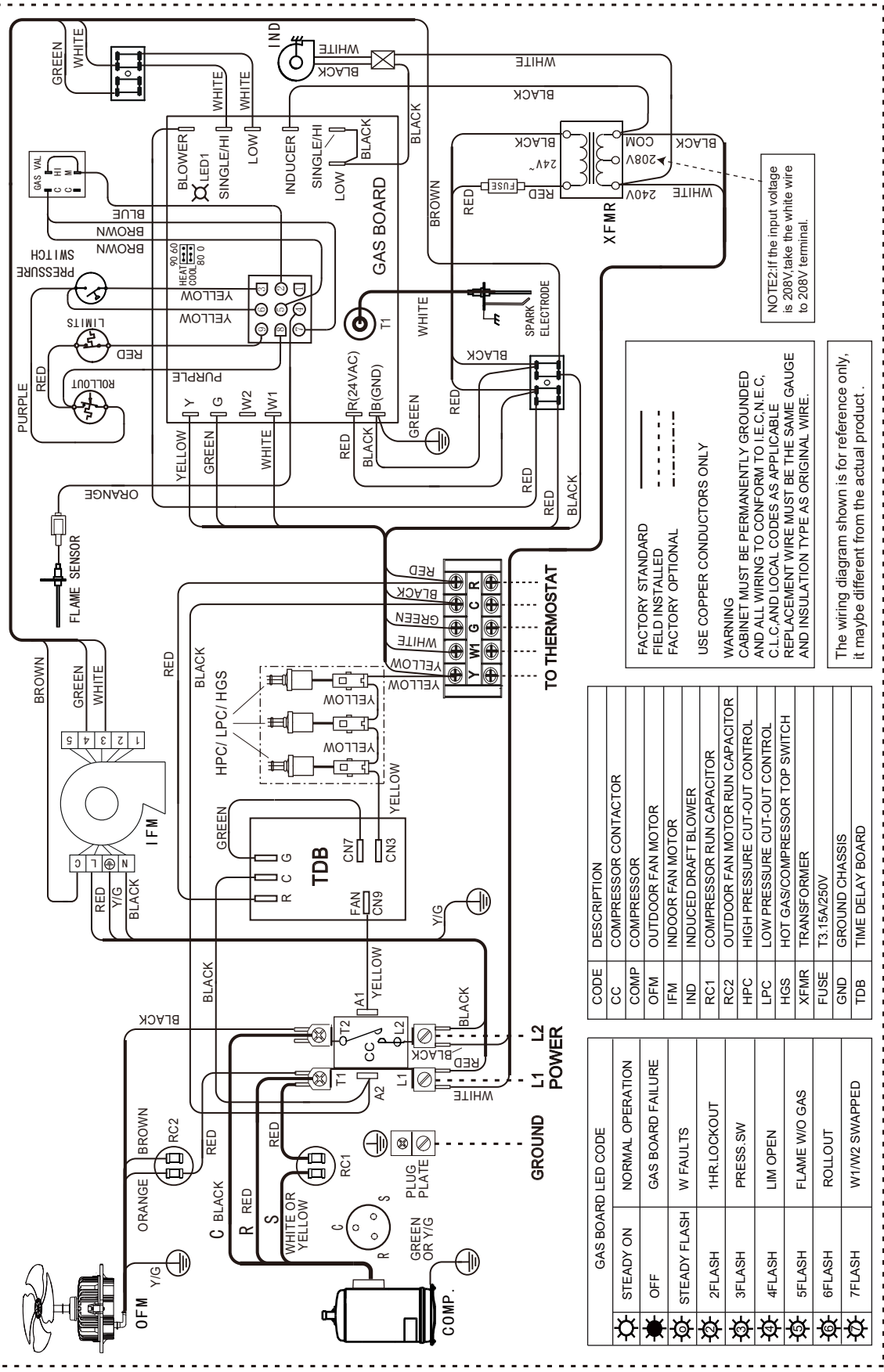

CODE	DESCRIPTION
CC	COMPRESSOR CONTACTOR
COMP	COMPRESSOR
OFM	OUTDOOR FAN MOTOR
IFM	INDOOR FAN MOTOR
IND	INDUCED DRAFT BLOWER
RC1	COMPRESSOR RUN CAPACITOR
RC2	OUTDOOR FAN MOTOR RUN CAPACITOR
HPC	HIGH PRESSURE CUT-OUT CONTROL
LPC	LOW PRESSURE CUT-OUT CONTROL
HGS	HOT GAS/COMPRESSOR TOP SWITCH
XFMR	TRANSFORMER
FUSE	T3.15A/250V
GND	GROUND CHASSIS
TDB	TIME DELAY BOARD

GAS BOARD LED CODE	DESCRIPTION
☀	STEADY ON
☀	NORMAL OPERATION
☀	OFF
☀	GAS BOARD FAILURE
☀	STEADY FLASH
☀	W FAULTS
☀	1HR LOCKOUT
☀	3FLASH
☀	PRESS. SW
☀	4FLASH
☀	LIM OPEN
☀	5FLASH
☀	FLAME W/O GAS
☀	6FLASH
☀	ROLLOUT
☀	7FLASH
☀	W1/W2 SWAPPED

--- FACTORY STANDARD  
 - - - FIELD INSTALLED  
 - · - · - FACTORY OPTIONAL  
 USE COPPER CONDUCTORS ONLY  
 WARNING  
 CABINET MUST BE PERMANENTLY GROUNDED  
 AND ALL WIRING TO CONFORM TO I.E.C.  
 C.L.C. AND LOCAL CODES AS APPLICABLE  
 REPLACEMENT WIRE MUST BE THE SAME GAUGE  
 AND INSULATION TYPE AS ORIGINAL WIRE.  
 The wiring diagram shown is for reference only,  
 it maybe different from the actual product .

**J4PG4048E1090AA**

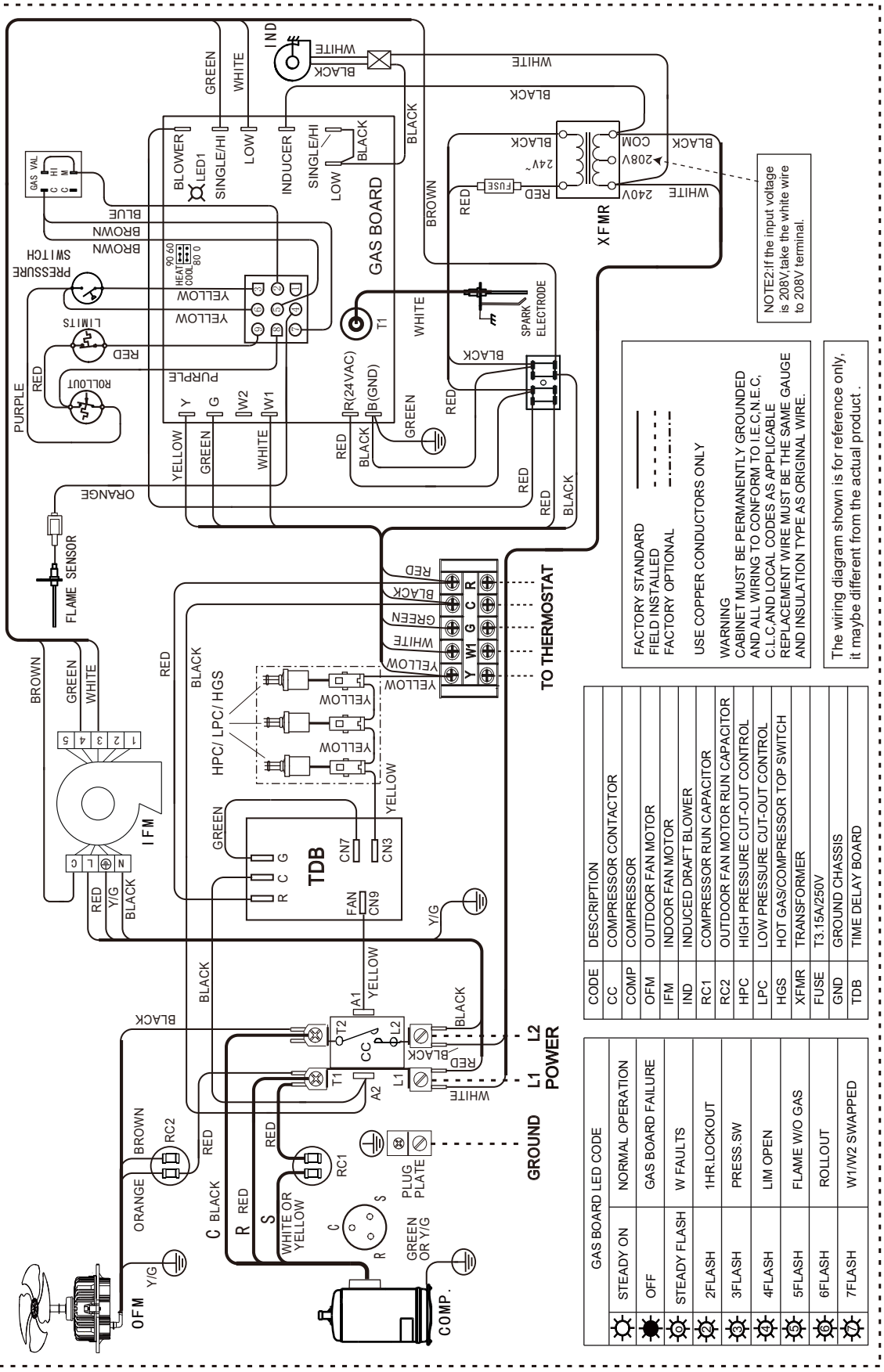

NOTE2: If the input voltage is 208V, take the white wire to 208V terminal.

FACTORY STANDARD  
 FIELD INSTALLED  
 FACTORY OPTIONAL  
 USE COPPER CONDUCTORS ONLY

WARNING  
 CABINET MUST BE PERMANENTLY GROUNDED  
 AND ALL WIRING TO CONFORM TO I.E.C./N.E.C.  
 C.L.C. AND LOCAL CODES AS APPLICABLE  
 REPLACEMENT WIRE MUST BE THE SAME GAUGE  
 AND INSULATION TYPE AS ORIGINAL WIRE.

The wiring diagram shown is for reference only,  
 it may be different from the actual product.

CODE	DESCRIPTION
CC	COMPRESSOR CONTACTOR
COMP	COMPRESSOR
OFM	OUTDOOR FAN MOTOR
IFM	INDOOR FAN MOTOR
IND	INDUCED DRAFT BLOWER
RC1	COMPRESSOR RUN CAPACITOR
RC2	OUTDOOR FAN MOTOR RUN CAPACITOR
HPC	HIGH PRESSURE CUT-OUT CONTROL
LPC	LOW PRESSURE CUT-OUT CONTROL
HGS	HOT GAS/COMPRESSOR TOP SWITCH
XFMR	TRANSFORMER
FUSE	T3.15A/250V
GND	GROUND CHASSIS
TDB	TIME DELAY BOARD

GAS BOARD LED CODE	DESCRIPTION
Steady On	NORMAL OPERATION
Off	GAS BOARD FAILURE
Steady Flash	W FAULTS
2 Flash	1HR LOCKOUT
3 Flash	PRESS. SW
4 Flash	LIM OPEN
5 Flash	FLAME W/O GAS
6 Flash	ROLLOUT
7 Flash	W1/W2 SWAPPED

# J4PG4060E1090AA

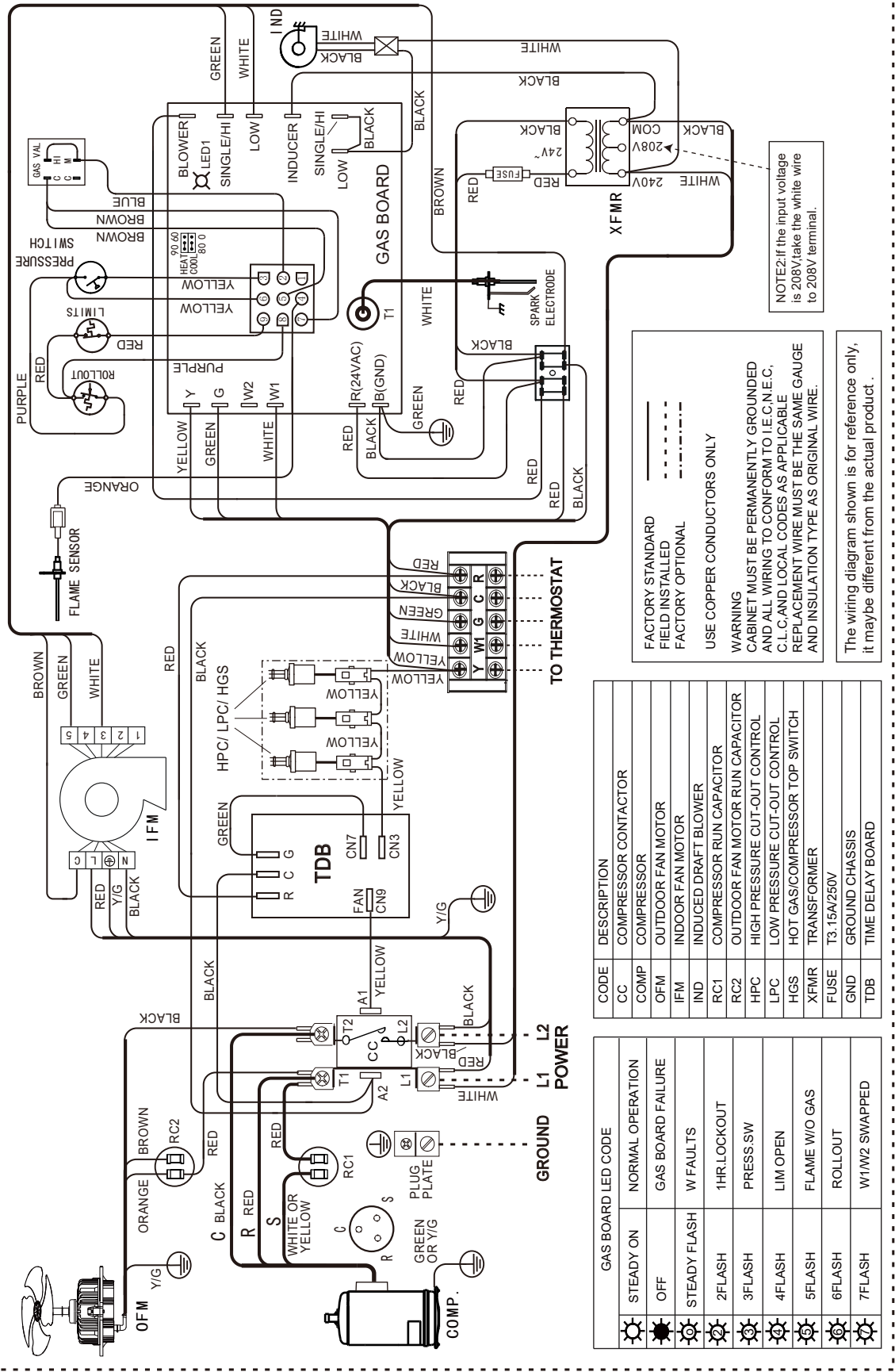

CODE	DESCRIPTION
CC	COMPRESSOR CONTACTOR
COMP	COMPRESSOR
OFM	OUTDOOR FAN MOTOR
IFM	INDOOR FAN MOTOR
IND	INDUCED DRAFT BLOWER
RC1	COMPRESSOR RUN CAPACITOR
RC2	OUTDOOR FAN MOTOR RUN CAPACITOR
HPC	HIGH PRESSURE CUT-OUT CONTROL
LPC	LOW PRESSURE CUT-OUT CONTROL
HGS	HOT GAS/COMPRESSOR TOP SWITCH
XFMR	TRANSFORMER
FUSE	T3.15A/250V
GND	GROUND CHASSIS
TDB	TIME DELAY BOARD

GAS BOARD LED CODE	
☀	STEADY ON
☀	NORMAL OPERATION
☀	OFF
☀	GAS BOARD FAILURE
☀	STEADY FLASH
☀	W FAULTS
☀	2 FLASH
☀	1HR LOCKOUT
☀	3 FLASH
☀	PRESS. SW
☀	4 FLASH
☀	LIM OPEN
☀	5 FLASH
☀	FLAME W/O GAS
☀	6 FLASH
☀	ROLL-OUT
☀	7 FLASH
☀	W1/W2 SWAPPED

# J4PG4060E110AA

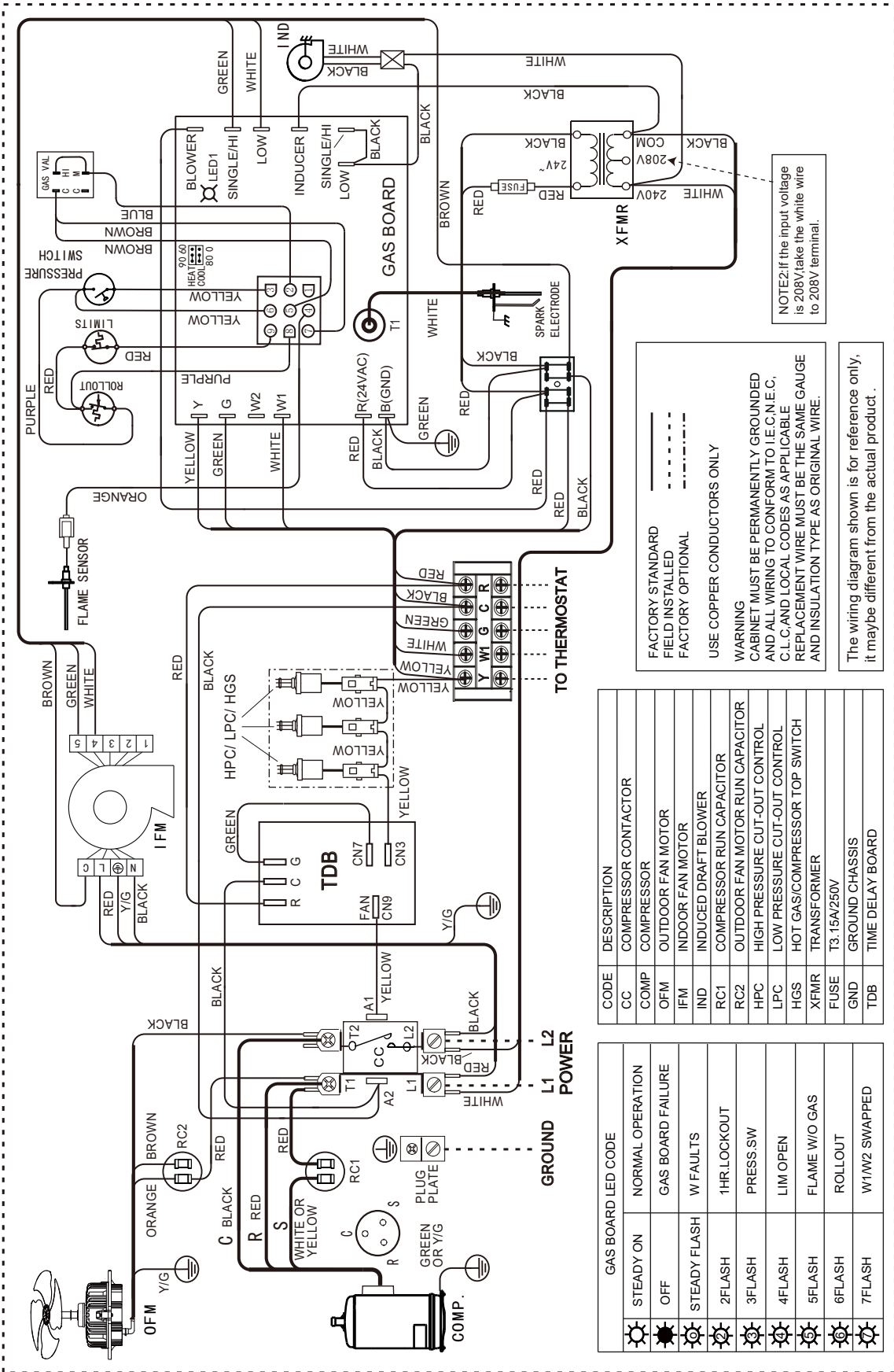

NOTE2: if the input voltage is 208V, take the white wire to 208V terminal.

FACTORY STANDARD  
 FIELD INSTALLED  
 FACTORY OPTIONAL

USE COPPER CONDUCTORS ONLY

WARNING  
 CABINET MUST BE PERMANENTLY GROUNDED  
 AND ALL WIRING TO CONFORM TO I.E.C.N.E.C.  
 C.L.C. AND LOCAL CODES AS APPLICABLE  
 REPLACEMENT WIRE MUST BE THE SAME GAUGE  
 AND INSULATION TYPE AS ORIGINAL WIRE.

The wiring diagram shown is for reference only,  
 it may be different from the actual product.

CODE	DESCRIPTION
CC	COMPRESSOR CONTACTOR
COMP	COMPRESSOR
OFM	OUTDOOR FAN MOTOR
IFM	INDOOR FAN MOTOR
IND	INDUCED DRAFT BLOWER
RC1	COMPRESSOR RUN CAPACITOR
RC2	OUTDOOR FAN MOTOR RUN CAPACITOR
HPC	HIGH PRESSURE CUT-OUT CONTROL
LPC	LOW PRESSURE CUT-OUT CONTROL
HGS	HOT GAS/COMPRESSOR TOP SWITCH
XFMR	TRANSFORMER
FUSE	T3.15A/250V
GND	GROUND CHASSIS
TDB	TIME DELAY BOARD

GAS BOARD LED CODE	
☀	STEADY ON
☀	NORMAL OPERATION
☀	OFF
☀	GAS BOARD FAILURE
☀	STEADY FLASH
☀	W FAULTS
☀	2 FLASH
☀	1HR LOCKOUT
☀	3 FLASH
☀	PRESS. SW
☀	4 FLASH
☀	LIM OPEN
☀	5 FLASH
☀	FLAME W/O GAS
☀	6 FLASH
☀	ROLLOUT
☀	7 FLASH
☀	W1/W2 SWAPPED



16127700000792 V.F

# 此页不做菲林，仅核对使用

## 印刷技术要求

材质	封面封底内页双胶纸80g
规格	A4规格
颜色	黑白
其他	

## 设计更改记录表（仅做说明用，不做菲林）

版本升级	更改人	更改日期	更改主要内容	涉及更改页面 (印刷页码)
A-B	李志方	23. 2. 28	ETL认证下行数字 冷量表 接线铭牌修改	封面、P27/28、 P33-39
B-C	李志方	23. 3. 30	增加安装前移除 蓝色玻璃棉要求 额定风量	P11、P27/28
C-D	卢炯	23. 4. 27	NOTE增加一段话 3. 1增加第八点 P32增加保险丝 说明 接线铭牌变更	P2. P11. P32. P33-P39
D-E	李志方	23. 5. 15	增加离心风轮拆装 指引	P32
E-F	常莹	25. 5. 26	目录单词修改 删除重复警示语 4. 4内容修改	目录、P2、P18