



**PRODUCT SPECIFICATIONS**

Bulletin No. 210727  
June 2016  
Supersedes April 2016

**LANDMARK®**

Performance Marked by Flexibility™



**ASHRAE 90.1  
COMPLIANT**

**2 to 7.5 Tons**

**Net Cooling Capacity - 24,200 to 90,000 Btuh**  
**Optional Electric Heat - 5 to 30 kW**

**MODEL NUMBER IDENTIFICATION**

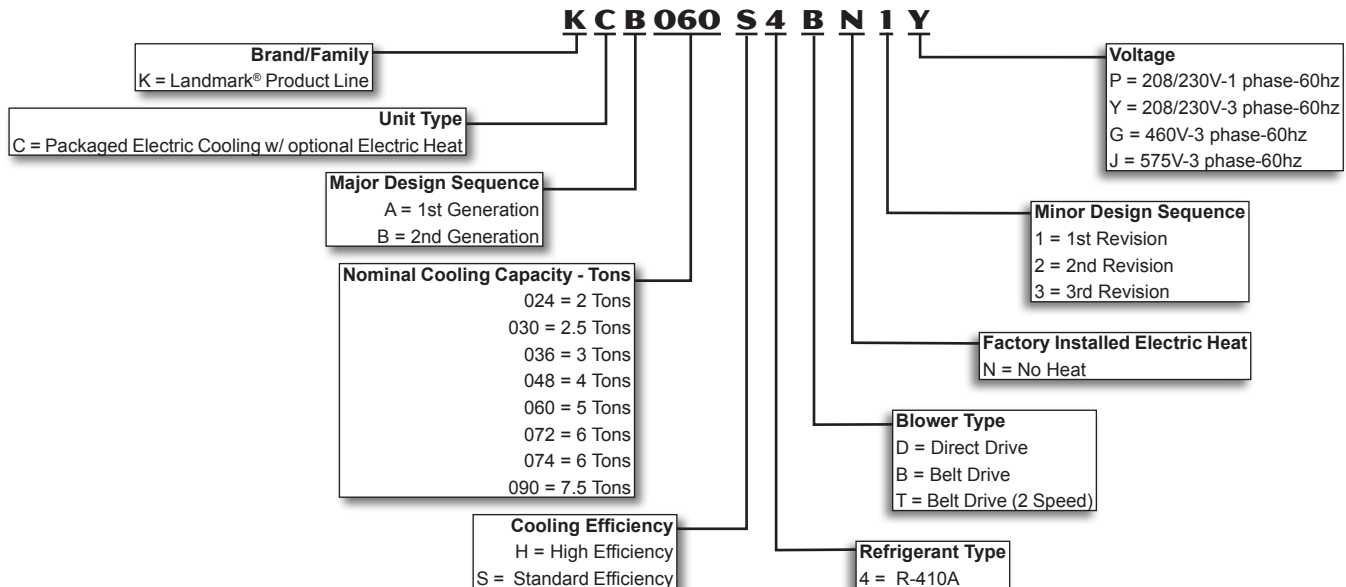

## FEATURES AND BENEFITS

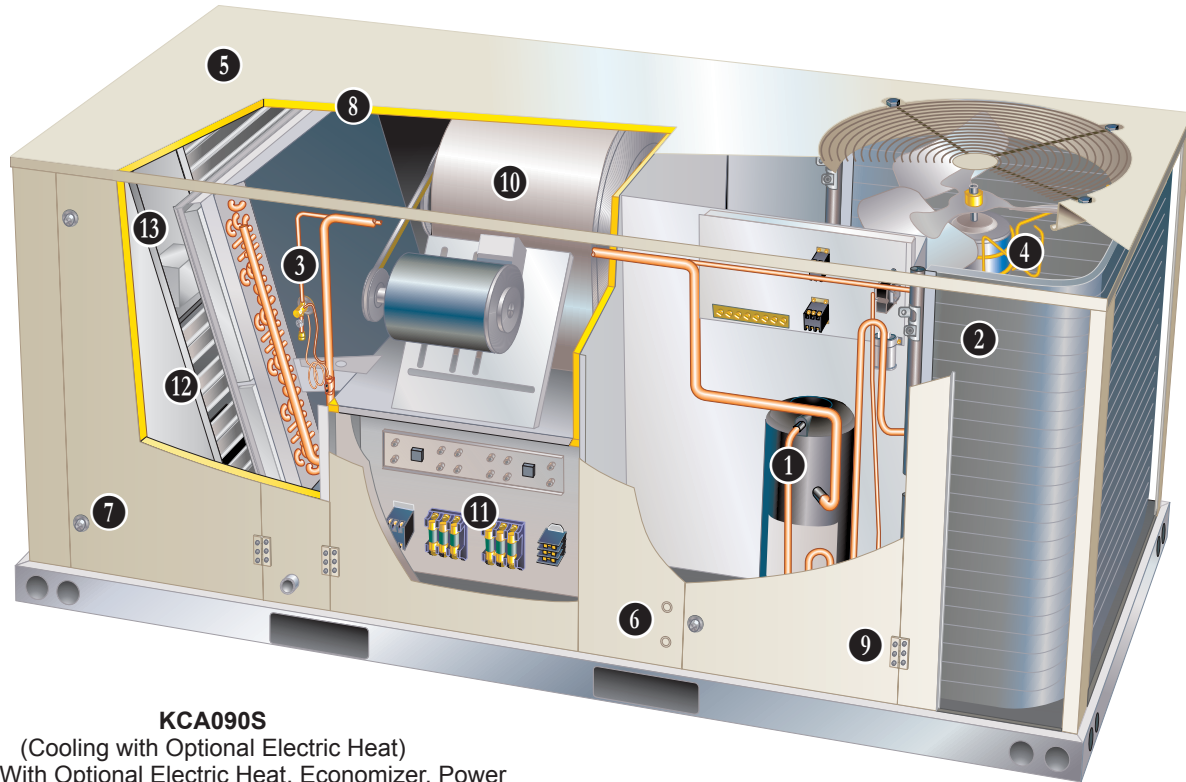

### KCA090S

(Cooling with Optional Electric Heat)

Shown With Optional Electric Heat, Economizer, Power Exhaust and Hinged Access Panels

Landmark® rooftop units from Lennox® are the new standard for reliable, efficient rooftop units built for long-lasting performance that can significantly improve indoor environments. Landmark® rooftop units feature:

- **R-410A Refrigerant** - Environmentally friendly.
- **Single Speed Scroll Compressor** - Furnished on all KCA and KCB024 through 060 models.
- **Two-Stage Scroll Compressor** - Furnished on all KCB074 models. Allows rooftop units to deliver just the necessary amount of cooling needed to meet the space's demand.
- **Lennox' Environ™ Coil System (All KCB Models and KCA072 and 090 Models)** - Smaller, lighter condenser coil with improved heat transfer.
- **High Pressure Switches** - Protect compressor.
- **Isolated Compressor Compartment** - Allows performance check during normal compressor operation without disrupting airflow.
- **Direct or Belt Drive Blower Motors** - Direct drive (024, 030, 036, 048 and 060 models). Belt drive motors (036, 048, 060, 072, 074 and 090 models) to maximize air performance.
- **Independent Motor Mounts** - Allows for easy and efficient service access without removing the top panel.
- **Downflow or Horizontal Airflow** - Easy field conversion.
- **Two Fork Lift Slots on Three Sides** - Easy to pick up and transport units from almost any angle.
- **Corrosion-Resistant Removable, Reversible Drain Pan** - Provides application flexibility, durability and improved serviceability.
- **Thermostatic Expansion Valves (All KCB Models)** - Provide peak cooling performance across the entire application range.
- **Common Components** - Many maintenance items are standard throughout the entire product line, reducing the need to carry different parts to the job or maintain in inventory.

## FEATURES AND BENEFITS

### CONTENTS

Blower Data - Belt Drive - KCA/KCB . . . . .	.29
Blower Data - Direct Drive - KCB . . . . .	.24
Dimensions - Accessories. . . . .	.62
Dimensions - Unit - KCA . . . . .	.60
Dimensions - Unit - KCB . . . . .	.61
Electrical/Electric Heat Data - KCA . . . . .	.52
Electrical/Electric Heat Data - KCB . . . . .	.42
Electric Heat Capacities. . . . .	.57
Features And Benefits . . . . .	2
Model Number Identification . . . . .	1
Optional Conventional Temperature Control Systems . . . . .	.58
Options / Accessories - KCA/KCB . . . . .	9
Options / Accessories - KCA Only . . . . .	.13
Options / Accessories - KCB Only . . . . .	.13
Outdoor Sound Data . . . . .	.41
Ratings - KCA. . . . .	.20
Ratings - KCB. . . . .	.21
Specifications - Belt Drive Blower - KCA . . . . .	.19
Specifications - Belt Drive Blower - KCB . . . . .	.16
Specifications - Direct Drive Blower- KCA . . . . .	.18
Specifications - Direct Drive Blower - KCB . . . . .	.14
Unit Clearances. . . . .	.57
Weight Data . . . . .	.59

### APPROVALS

AHRI Certified to AHRI Standard 210/240-2008 (2 - 5 ton models) and AHRI Standard 340/360-2007 (6 and 7.5 ton models).

ETL listed.

CSA listed.

Components bonded for grounding to meet safety standards for servicing required by UL, ULC and National and Canadian Electrical Codes.

All models are ASHRAE 90.1 compliant.

ISO 9001 Registered Manufacturing Quality System.

### WARRANTY

Limited five years on compressors.

Limited three years on the Lennox' Environ™ Coil System.

Limited five years Optional High Performance Economizers.

Limited one year all other covered components.

### COOLING SYSTEM

Designed to maximize sensible and latent cooling performance at design conditions.

System can operate from 30°F to 125°F without any additional controls.

#### R-410A Refrigerant

Non-chlorine, ozone friendly, R-410A.



Unit is factory pre-charged with refrigerant. See Specifications Tables.

#### 1 Single Speed Scroll Compressor (024 through 072 and 090 Models)

Scroll compressors for high performance, reliability and quiet operation.

Resiliently mounted on rubber grommets for quiet operation.

#### Copeland Scroll Ultra Tech™ Two-Stage Compressor (074 Models)

Two-stage scroll compressors for increased part load efficiency, high performance, reliability and quiet operation.

Resiliently mounted on rubber grommets for quiet operation.

#### Compressor Crankcase Heater (Furnished all KCB Models and KCA072 and 090 Models)

Protects against refrigerant migration that can occur during low ambient operation.

#### 2 Lennox' Environ™ Coil System (All KCB Models and KCA072 and 090 Models)

Condenser coil features lightweight, all aluminum brazed fin construction.

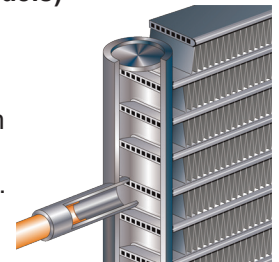

Constructed of three components: a flat extrusion tube, fins in-between the flat extrusion tubes and two refrigerant manifolds.

Environ™ Coil System Features:

- Improved heat transfer performance due to high primary surface area (flat tubes) versus secondary surface (fins).
- Smaller internal volume (reduced refrigerant charge).
- High durability (all aluminum construction).
- Fewer brazed joints.
- Compact design (reduces unit weight).
- Easy maintenance/cleaning.

Mounting brackets with rubber inserts secure coil to unit providing vibration dampening and corrosion protection.

## FEATURES AND BENEFITS

### **COOLING SYSTEM**

#### **(continued)**

#### **Conventional Fin/Tube Coil (Condenser Coil for KCA036 thru 060 Models) and Evaporator Coil (all models)**

Copper tube construction, enhanced rippled-edge aluminum fins, flared shoulder tubing connections, silver soldered construction for improved heat transfer. Factory leak tested

Evaporator coil cross row circuiting with rifled tubing optimizes both sensible and latent cooling capacity.

#### **3 Thermal Expansion Valve (All KCB Models)**

Assures optimal performance throughout the application range. Removable element head.

#### **Refrigerant Metering Orifice (All KCA Models)**

Accurately meters refrigerant in system.

Refrigerant control is accomplished by exact sizing of refrigerant metering orifice.

#### **High Pressure Switch**

Protects the compressor from overload conditions such as dirty condenser coils, blocked refrigerant flow, or loss of outdoor fan operation.

#### **Filter/Drier**

High capacity filter/drier protects the system from dirt and moisture.

#### **Freezestat**

Protects the evaporator coil from damaging ice build-up due to conditions such as low/no air flow, or low refrigerant charge.

#### **Condensate Drain Pan**

Plastic pan, sloped to meet drainage requirements of ASHRAE 62.1.

Side or bottom drain connections. Reversible to allow connection at back of unit.

#### **4 Outdoor Coil Fan Motor**

Thermal overload protected, totally enclosed, permanently lubricated sleeve bearings (024, 030, 036 and 048 models) or ball bearings (060, 072, 074 and 090 models), shaft up, wire basket mount.

#### **Outdoor Coil Fan**

PVC coated fan guard furnished.

#### **Required Selections**

#### **Cooling Capacity**

Specify nominal cooling capacity of the unit.

#### **Options/Accessories**

#### **Field Installed**

#### **Condensate Drain Trap**

Field installed only.

Available in copper or PVC.

#### **Compressor Crankcase Heater (Optional for KCA036 thru 060 Models Only)**

Protects against refrigerant migration that can occur during low ambient operation.

#### **Drain Pan Overflow Switch**

Monitors condensate level in drain pan, shuts down unit if drain becomes clogged.

#### **Low Ambient Kit**

Cycles the outdoor fan while allowing compressor operation in the cooling cycle. This intermittent fan operation allows the system to operate without icing the evaporator coil and losing capacity. Designed for use in ambient temperatures no lower than 0°F. A crankcase heater must be installed on the compressor.

### **CABINET**

#### **5 Construction**

Heavy-gauge steel panels and full perimeter heavy-gauge galvanized steel base rail provides structural integrity for transportation, handling, and installation.

Base rails have rigging holes.

Three sides of the base rail have fork slots.

Raised edges around duct and power entry openings in the bottom of the unit provide additional protection against water entering the building.

#### **Airflow Choice**

Units are shipped in downflow (vertical) configuration, can be field converted to horizontal air flow configuration without the need of a kit.

#### **6 Power Entry**

Electrical lines can be brought through the unit base or through horizontal access knock-outs.

#### **7 Exterior Panels**

Constructed of heavy-gauge, galvanized steel with a two-layer enamel paint finish.

#### **8 Insulation**

All panels adjacent to conditioned air are fully insulated with non-hygroscopic fiberglass insulation.

Unit base is fully insulated. The insulation also serves as an air seal to the roof curb, eliminating the need to add a seal during installation.

#### **Access Panels**

Access panels are provided for the economizer/filter section, heating/blower section, and the compressor/controls section.

*NOTE - KCA072/090 and KCB060/074 models include a filler panel for proper cabinet fit for optional accessories (Economizers, Power Exhaust, Outdoor Air Dampers and Barometric Relief Dampers).*

## FEATURES AND BENEFITS

### **CABINET (continued)**

#### **Options/Accessories**

##### **Factory Installed**

##### **Corrosion Protection**

A completely flexible immersed coating with an electrodeposited dry film process. (AST ElectroFin E-Coat) Meets Mil Spec MIL-P-53084, ASTM B117 Standard Method Salt Spray Testing.

Indoor Corrosion Protection:-  
Coated coil

- Painted blower housing
- Painted base

Outdoor Corrosion Protection:

- Coated coil
- Painted base

##### **9 Hinged Access Panels**

Large access panels are hinged and have quarter-turn latches for quick and easy access to maintenance areas (economizer / filter, compressor / controls, heating / blower).

##### **Field Installed**

##### **Combination Coil/Hail Guards**

Heavy gauge steel frame painted to match cabinet with expanded metal mesh to protect the outdoor coil from damage.

### **CONTROLS**

#### **Unit Control**

All control voltage is provided via a 24V (secondary) transformer with built-in circuit breaker protection.

**Heat/Cool Staging** - Capable of up to 1 heat / 2 cool staging with a third party DDC control system or thermostat.

#### **Low Voltage Terminal Block -**

Provides screw terminal connections for thermostat or controller wiring.

**Night Setback Mode** - Saves energy by closing outdoor air dampers and operating supply fan on thermostat demand only.

#### **Options/Accessories**

##### **Field Installed**

#### **Commercial Control Systems**

##### **L Connection® Network**

Complete building automation control system for single or multi-zone applications. Options include local interface, software for local or remote communication, and hardware for networking other control functions. See L Connection Network Product Specifications Bulletin for details.

##### **Smoke Detector**

Photoelectric type, installed in supply air section, return air section or both sections. Available with power board and single sensor (supply or return) or power board and two sensors (supply and return). Power board located in unit control compartment.

##### **Thermostats**

Control system and thermostat options, see page 58.

Aftermarket unit controller options, see Options/Accessories table.

### **10 BLOWER**

A wide selection of supply air blower options are available to meet a variety of air flow requirements.

#### **Motor**

Overload protected, equipped with ball bearings (belt drive) or sleeve bearings (direct drive).

Direct drive motors are offered on 024, 030, 036, 048 and 060 models.

Single Speed belt drive motors are offered on 036, 048, 060, 072 and 090 models and are available in several different sizes to maximize air performance.

Two-speed belt drive motors (low static/high static) are available on 074 models in several different sizes to maximize air performance.

#### **Supply Air Blower**

Forward curved blades, blower wheel is statically and dynamically balanced.

All belt drive motors have adjustable pulley for speed change.

#### **Ordering Information**

Specify direct drive or belt drive motor.

For belt drive, specify motor horsepower and drive kit number when base unit is ordered.

#### **Required Selections**

##### **Supply Air Blower**

Order one, belt drive or direct drive (See Blower Data Table for specifications).

Order one drive kit, belt drive only, see Drive Kit Specifications Table.

## FEATURES AND BENEFITS

### INDOOR AIR QUALITY

#### **Air Filters**

Disposable 2 inch filters furnished as standard.

#### **Options/Accessories**

#### Field Installed

#### **Healthy Climate® High Efficiency Air Filters**

Disposable MERV 8 or MERV 13 (Minimum Efficiency Reporting Value based on ASHRAE 52.2) efficiency 2 inch pleated filters.

#### **Healthy Climate® UVC Germicidal Lamps**

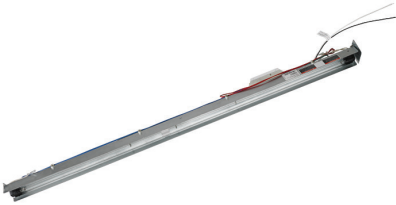

Helps eliminate mold and bacterial growth on the evaporator and drain pans. Improves indoor air quality and maintains efficiency of system by reducing fouling of evaporator coil.

#### **Indoor Air Quality (CO<sub>2</sub>) Sensor**

Monitors CO<sub>2</sub> levels adjusts economizer dampers as needed for Demand Control Ventilation

### ELECTRICAL

#### **Marked & Color-Coded Wiring**

All electrical wiring is color-coded and marked to identify which components it is connecting.

#### **Electrical Plugs**

Positive connection electrical plugs are used to connect common accessories or maintenance parts for easy removal or installation.

#### **Required Selections**

#### **Voltage Choice**

Specify when ordering base unit.

#### **Options/Accessories**

#### Factory or Field Installed

#### **Disconnect Switch up to 150 Amp**

Accessible from outside of unit, spring loaded weatherproof cover furnished. Main power to the unit is field connected to the disconnect which allows all power to be shut off for service. See Electrical/ Electric Heat Data tables for ordering information, page 42.

#### **GFI Service Outlets (2)**

115V ground fault circuit interrupter (GFCI) type, non-powered, field-wired.

#### Field Installed

#### **11 Electric Heat**

Helix wound nichrome elements, individual element limit controls, wiring harness. Unit fuse block is furnished as standard. See Options / Accessories tables for ordering information.

#### **GFI Weatherproof Cover**

Single-gang cover.

Heavy-duty UV-resistant polycarbonate case construction.

Hinged base cover with gasket.

**ECONOMIZER OPTIONS**

**Factory or Field Installed**

**12 Economizer (Standard and High Performance Common Features)**

Outdoor Air Hood is furnished.

Factory installed Economizer can be ordered with two exhaust options:

- Barometric Relief Dampers and Exhaust Hood.
- No Exhaust.

Field installed Economizer includes Barometric Relief Dampers with Exhaust Hood.

Barometric Relief Dampers allow relief of excess air, aluminum blade dampers prevent blow back and outdoor air infiltration during off cycle, bird screen furnished.

Occupied/Unoccupied mode with field furnished setback thermostat.

Demand Control Ventilation (DCV) ready using optional CO<sub>2</sub> sensors.

Mixed Air Sensor is furnished for field installation in the rooftop unit. Sensor is factory installed when Economizers are factory installed.

Single sensible sensor is furnished with Economizer and enables economizer operation if the outdoor temperature is less than the setpoint of the control.

Horizontal Economizer Conversion kit is available for field installation.

**Standard Economizer Features (Not for Title 24)**

Gear-driven action, return air and outdoor air dampers, plug-in connections to unit, neoprene seals, 24-volt, fully-modulating spring return motor.

**Standard Economizer Control Module**

The Standard Economizer Control Module can be adjusted to operate based on outdoor air temperatures.



**Economizer Controls:**

- Damper Minimum Position - Can be set lower than traditional minimum air requirements resulting in cost savings.
- IAQ Sensor - Signals dampers to modulate and maintain 55°F when CO<sub>2</sub> is higher than the CO<sub>2</sub> setpoint.
- Demand Control Ventilation (DCV) LED - A steady green Demand Control Ventilation LED indicates the IAQ reading is higher than setpoint and requires more fresh air.
- Free Cool LED - A steady green LED indicates outdoor air is suitable for free cooling.

Free Cooling runs when outdoor air temperature is lower than the set temperature on the economizer control.

*NOTE: The Free Cooling default setting for outdoor air temperature sensor is 55°F.*

**High Performance Economizer Features**

Approved for California Title 24 building standards.

ASHRAE 90.1-2010 compliant.

Gear-driven action, high torque 24-volt fully-modulating spring return damper motor, return air and outdoor air dampers, plug-in connections to unit, nylon bearings, enhanced neoprene blade edge seals and flexible stainless steel jamb seals to minimize air leakage.

*NOTE - High Performance Economizers are not approved for use with enthalpy controls in Title 24 applications.*

**High Performance Economizer Control Module**

Module provides inputs and outputs to control economizer based on parameter settings.



Module automatically detects sensors by polling to determine which sensors are installed in system.

Module displays any alarm messages (fault detection and diagnostics) as an aid in troubleshooting.

Non-volatile memory retains parameter settings in case of power failure.

Keypad with four navigation buttons and LCD screen is furnished for setting economizer parameters.

- Menu Up/Exit (↑) button returns to the main menu.
- Arrow Up (▲) button moves to the previous or next parameter within the selected menu.
- Arrow Down (▼) button moves to the next parameter within the selected menu.
- Select (enter) (↵) button confirms parameter selection.

**Main Menu Structure:**

- STATUS (economizer and system operation status)
- SETPOINTS (settings for various setpoint parameters)
- SYSTEM SETUP (settings/information about the system)
- ADVANCED SETUP (freeze protection, CO<sub>2</sub> settings, stage 3 delay and additional calibration settings)
- CHECKOUT (damper positions)
- ALARMS (output signal that can be configured for remote alarm monitoring)

*NOTE - The Free Cooling setpoint for Title 24 applications must be set based on the Climate Zone where the system is installed. See Section 140.4 "Prescriptive Requirements for Space Conditioning Systems" of the California Energy Commission's 2013 Building Energy Efficiency Standards.*

Refer to Installation Instructions for complete setup information and menu parameters available.

## OPTIONS / ACCESSORIES

### **ECONOMIZER OPTIONS**

#### **(continued)**

#### **Factory or Field Installed**

##### **Single Enthalpy Temperature Control**

###### **(Not for Title 24)**

Outdoor air enthalpy sensor enables Economizer if the outdoor enthalpy is less than the setpoint of the control.

#### **Field Installed**

##### **Differential Enthalpy Control (Not for Title 24)**

Order two Single Enthalpy Controls. One is field installed in the return air section, the other in the outdoor air section. Allows the economizer control board to select between outdoor air or return air, whichever has lower enthalpy.

##### **Horizontal Economizer Conversion Kit**

Insulated panel covers the bottom return air opening on the unit base to convert downflow Economizer to horizontal airflow.

### **EXHAUST OPTIONS**

#### **Field Installed**

#### **13 Power Exhaust Fan**

Installs internal to unit for downflow applications only with Economizer option. Provides exhaust air pressure relief. Interlocked to run when supply air blower is operating, fan runs when outdoor air dampers are 50% open (adjustable), motor is overload protected.

Fan is 16 in. diameter with 4 fan blades and a 1/3 hp motor.

*NOTE - Not available for 024 and 030 models.*

*NOTE - If Power Exhaust is field installed with a factory installed Economizer, the Economizer must be ordered with the "No Exhaust" option and the Barometric Relief Dampers with Exhaust Hood must also be ordered separately for field installation.*

### **OUTDOOR AIR OPTIONS**

#### **Factory or Field Installed**

##### **Outdoor Air Dampers - Downflow or Horizontal**

Linked mechanical dampers, 0 to 35% (fixed) outdoor air adjustable, installs in unit.

Automatic model features fully modulating spring return damper motor with plug-in connection.

Manual model features a slide damper. Maximum mixed air temperature in cooling mode: 100°F.

Outdoor Air Hood is furnished.

### **ROOF CURBS**

Nailer strip furnished, mates to unit, US National Roofing Contractors Approved, shipped knocked down.

#### **Hybrid Roof Curbs, Downflow**

Roof curb can be assembled using interlocking tabs to fasten corners together. No tools required.

Curb can also be fastened together with furnished hardware.

Available in 8, 14, 18, and 24 inch heights.

#### **Full Perimeter Curbs, Downflow (090 Models Only)**

Hybrid roof curbs can be assembled using interlocking tabs to fasten corners together. No tools required.

Hybrid roof curbs can also be fastened together with furnished hardware.

Available in 8, 14, 18, and 24 inch heights.

*NOTE - 090 models can be used on smaller 79-3/4 in. Hybrid Roof Curbs (not full perimeter) with 15-3/4 in. overhang at condenser end of unit. See dimension drawing on page 66.*

#### **Adjustable Pitch Curb**

Fully adjustable pitch curb provides a level platform for rooftop units allowing flexible installations on roofs with uneven or sloped angles.

Maximum slope is 3/4 in. per foot in any direction.

Uses interlocking tabs to fasten corners together. No tools required.

Hardware is furnished to connect upper curb with lower curb.

Available in 14 inch height.

#### **Adaptor Curbs (not shown)**

Curbs are regionally sourced.

Dimensions will vary based upon the source. Contact your local sales representative for a detailed cut sheet with applicable dimensions.

### **CEILING DIFFUSERS**

#### **Ceiling Diffusers (Flush and Step-Down)**

Diffuser face and grilles with white powder coat finish, insulated (UL listed duct liner), diffuser box with collars for duct connection, fixed blades (flush diffusers) and double deflection blades (step-down diffusers), provisions for suspending, internally sealed (prevents recirculation), removable return air grille, adapts to T-bar ceiling grids or plaster ceilings.

#### **Transitions (Supply and Return)**

Used with diffusers, installs in roof curb, galvanized steel construction, flanges furnished for duct connection to diffusers, fully insulated.



## OPTIONS / ACCESSORIES - KCA/KCB

Item	Model No.	Catalog No.	Unit Model No.							
			KCA 024	KCA 030	KCA 036	KCA 048	KCA 060	KCA 072	KCA 074	KCA 090
			KCB 024	KCB 030	KCB 036	KCB 048	KCB 060	KCB 072	KCB 074	KCB 090
<b>COOLING SYSTEM</b>										
Condensate Drain Trap	PVC - C1TRAP20AD2	76W26	X	X	X	X	X	X	X	X
	Copper - C1TRAP10AD2	76W27	X	X	X	X	X	X	X	X
Drain Pan Overflow Switch	K1SNSR71AB1-	74W42	X	X	X	X	X	X	X	X
Low Ambient Kit	K1SNSR33AN2	14D89	X	X	X	X	X	X	X	X
Efficiency	High								O	
	Standard		O	O	O	O	O	O	O	O
Refrigerant Type	R-410A		O	O	O	O	O	O	O	O
<b>BLOWER - SUPPLY AIR</b>										
Motors	Direct Drive - 0.25 hp (208/230V-1ph)	Factory	O	O						
	Direct Drive - 0.5 hp (208/230V-1ph, 208/230V-3ph, 460V-3ph, 575V-3ph)	Factory			O	O				
	Direct Drive - 0.75 hp (208/230V-1ph, 208/230V-3ph, 460V-3ph, 575V-3ph)	Factory					O			
	Belt Drive - 0.75 hp (208/230V-1ph) Standard Efficiency	Factory			<sup>1</sup> O	<sup>1</sup> O	<sup>1</sup> O			
	Belt Drive - 1.5 hp (208/230V-1ph) Standard Efficiency	Factory			<sup>1</sup> O	<sup>1</sup> O	<sup>1</sup> O			
	Belt Drive - 1 hp (208/230V, 460V, 575V-3ph) Standard Efficiency	Factory			O	O	O	<sup>2</sup> O	<sup>2</sup> O	O
	Belt Drive - 2 hp (208/230V, 460V, 575V-3ph) Standard Efficiency	Factory			O	O	O	<sup>2</sup> O	<sup>2</sup> O	O
	Belt Drive - 3 hp (208/230V, 460V, 575V-3ph) Standard Efficiency	Factory								O
	Belt Drive - 1 hp (208/230V, 460V, 575V-3ph) ( 2 Speed)	Factory						<sup>3</sup> O	<sup>3</sup> O	
	Belt Drive - 2 hp (208/230V, 460V, 575V-3ph) (2 Speed)	Factory						<sup>3</sup> O	<sup>3</sup> O	
Drive Kits	Kit A01 - T1DRKT001-1 - 673-1010 rpm	Factory			O					
See Blower Data Tables for selection	Kit A02 - T1DRKT002-1 - 745-1117 rpm	Factory				O				
	Kit A03 - T1DRKT003-1 - 833-1250 rpm	Factory					O			
	Kit A04 - T1DRKT004-1 - 968-1340 rpm	Factory						<sup>2</sup> O	<sup>2</sup> O	
	Kit A05 - T1DRKT005-1 - 897-1346 rpm	Factory			O					
	Kit A06 - T1DRKT006-1 - 1071-1429 rpm	Factory				O				
	Kit A07 - T1DRKT007-1 - 1212-1548 rpm	Factory					O			
	Kit A08 - T1DRKT008-1 - 1193-1591 rpm	Factory						<sup>2</sup> O	<sup>2</sup> O	
	Kit AA01 - T1DRKT001AP1 - 522-784 rpm	Factory						<sup>3</sup> O	<sup>3</sup> O	O
	Kit AA02 - T1DRKT002AP1 - 632-875 rpm	Factory						<sup>3</sup> O	<sup>3</sup> O	O
	Kit AA03 - T1DRKT003AP1 - 798-1105 rpm	Factory						<sup>3</sup> O	<sup>3</sup> O	O
	Kit AA04 - T1DRKT004AP1 - 921-1228 rpm	Factory								O
<b>CABINET</b>										
Corrosion Protection			O	O	O	O	O	O	O	O
Hinged Access Panels			O	O	O	O	O	O	O	O
<b>CONTROLS</b>										
Commercial Controls	L Connection® Building Automation System	- - -	X	X	X	X	X	X	X	X
BACnet® Thermostat with Display	K0SNSR01FF1	97W23	X	X	X	X	X	X	X	X
BACnet® Thermostat without Display	K0SNSR00FF1	97W24	X	X	X	X	X	X	X	X
Plenum Cable (75 ft.)	K0MISC00FF1	97W25	X	X	X	X	X	X	X	X
Smoke Detector - Supply or Return (Power board and one sensor)	C1SNSR44AP1	53W78	X	X	X	X	X	X	X	X
Smoke Detector - Supply and Return (Power board and two sensors)	C1SNSR43AP1	53W79	X	X	X	X	X	X	X	X

<sup>1</sup> 1 phase belt drive blower motors are available for KCB models only.

<sup>2</sup> 072S and 074S Single Speed Belt Drive models only.

<sup>3</sup> 072H and 074H Two-Speed Belt Drive models only.

NOTE - The catalog and model numbers that appear here are for ordering field installed accessories only.

OX - Field Installed or Configure to Order (factory installed)

O - Configure to Order (Factory Installed)

X - Field Installed.

## OPTIONS / ACCESSORIES - KCA/KCB

Item	Model No.	Catalog No.	Unit Model No.							
			KCB 024	KCB 030	KCA KCB 036	KCA KCB 048	KCA KCB 060	KCA KCB 072	KCA KCB 074	KCA 090
<b>ECONOMIZER</b>										
<b>Standard Economizer With Outdoor Air Hood (Sensible Control) (Not for Title 24)</b>										
Standard Economizer - Includes Barometric Relief Dampers and Exhaust Hood	K1ECON30A-3-	14D90	OX	OX	OX	OX	OX	OX	OX	OX
Standard Economizer - No Exhaust		Factory	O	O	O	O	O	O	O	O
<b>Standard Economizer Controls (Not for Title 24)</b>										
Single Enthalpy Control	C1SNSR64FF1	53W64	OX	OX	OX	OX	OX	OX	OX	OX
Differential Enthalpy Control (order 2)	C1SNSR64FF1	53W64	X	X	X	X	X	X	X	X
<b>High Performance Economizer With Outdoor Air Hood (Sensible Control) (Approved for California Title 24 Building Standards)</b>										
High Performance Economizer - Includes Barometric Relief Dampers and Exhaust Hood	K1ECON32A-2	14D91	OX	OX	OX	OX	OX	OX	OX	OX
<b>High Performance Economizer Controls (Not for Title 24)</b>										
Single Enthalpy Control	C1SNSR60FF1	10Z75	OX	OX	OX	OX	OX	OX	OX	OX
Differential Enthalpy Control (order 2)	C1SNSR60FF1	10Z75	X	X	X	X	X	X	X	X
<b>Economizer Accessories</b>										
Horizontal Economizer Conversion Kit	T1HECK00AN1	17W45	X	X	X	X	X	X	X	X
<b>OUTDOOR AIR</b>										
<b>Outdoor Air Dampers With Outdoor Air Hood</b>										
Motorized	K1DAMP21A-1	79W95	OX	OX	OX	OX	OX	OX	OX	OX
Manual	C1DAMP11A-1	53W34	OX	OX	OX	OX	OX	OX	OX	OX
<b>POWER EXHAUST FAN</b>										
Standard Static	208/230V-1 or 3ph - C1PWRE10A-1P	79W87			X	X	X	X	X	X
<i>NOTE - Order Barometric Relief Dampers with Exhaust Hood below if unit is ordered with factory installed Standard Economizer with "No Exhaust" option</i>	460V-3ph - C1PWRE10A-1G	79W88			X	X	X	X	X	X
	575V-3ph - C1PWRE10A-1J	79W89			X	X	X	X	X	X
<b>' BAROMETRIC RELIEF</b>										
Barometric Relief Dampers with Exhaust Hood	C1DAMP50A-1-	74W38	X	X	X	X	X	X	X	X
<b>ELECTRICAL</b>										
Voltage	208/230V - 1 phase		O	O	<sup>2</sup> O	<sup>2</sup> O	<sup>2</sup> O			
60 hz	208/230V - 3 phase				O	O	O	O	O	O
	460V - 3 phase				O	O	O	O	O	O
	575V - 3 phase				O	O	O	O	O	O
Disconnect	See Electrical/Electric Heat Tables for selection		OX	OX	OX	OX	OX	OX	OX	OX
GFI	15 amp non-powered, field-wired (208/230V, 460V only) LTAGFIK10/15	74M70	OX	OX	OX	OX	OX	OX	OX	OX
Service Outlets	20 amp non-powered, field-wired (575V only) C1GFIC120FF1	67E01	X	X	X	X	X	X	X	X
Weatherproof Cover for GFI	C1GFIC199FF1	10C89	X	X	X	X	X	X	X	X

<sup>1</sup> Required when Economizer is factory installed (no exhaust option) with field installed Power Exhaust Fan option.

<sup>2</sup> KCB models only.

NOTE - The catalog and model numbers that appear here are for ordering field installed accessories only.

OX - Field Installed or Configure to Order (factory installed)

O - Configure to Order (Factory Installed)

X - Field Installed.

## OPTIONS / ACCESSORIES - KCA/KCB

Item	Model No.	Catalog No.	Unit Model No.							
			KCB 024	KCB 030	KCA KCB 036	KCA KCB 048	KCA KCB 060	KCA KCB 072	KCA KCB 074	KCA 090
<b>ELECTRIC HEAT</b>										
5 kW	208/230V- 1ph - K1EH0050A-1P	12F06	X	X						
7.5 kW	208/230V-1ph - T1EH0075AN1P	14W32	X	X	<sup>1</sup> X	<sup>1</sup> X	<sup>1</sup> X			
	208/230V-3ph - T1EH0075AN1Y	14W35			X	X	X	X	X	X
	460V-3ph - T1EH0075AN1G	14W39			X	X	X	X	X	X
	575V-3ph - T1EH0075AN1J	14W43			X	X	X	X	X	X
10 kW	208/230V-1ph - T1EH0100A1P	30W26	X	X						
15 kW	208/230V-1ph - T1EH0150AN1P	14W33			<sup>1</sup> X	<sup>1</sup> X	<sup>1</sup> X			
	208/230V-3ph - T1EH0150AN1Y	14W36			X	X	X	X	X	X
	460V-3ph - T1EH0150AN1G	14W40			X	X	X	X	X	X
	575V-3ph - T1EH0150AN1J	14W44			X	X	X	X	X	X
22.5 kW	208/230V-1ph - T1EH0225AN1P	14W34					<sup>1</sup> X			
	208/230V-3ph - T1EH0225AN1Y	14W37					X	X	X	X
	460V-3ph - T1EH0225AN1G	14W41					X	X	X	X
	575V-3ph - T1EH0225AN1J	14W45					X	X	X	X
30 kW	208/230V-3ph - T1EH0300N-1Y	14W38						X	X	X
	460V-3ph - T1EH0300N-1G	14W42						X	X	X
	575V-3ph - T1EH0300N-1J	14W46						X	X	X

## INDOOR AIR QUALITY

### Indoor Air Quality (CO<sub>2</sub>) Sensors

Sensor - Wall-mount, off-white plastic cover with LCD display	C0SNSR50AE1L	77N39	X	X	X	X	X	X	X	X
Sensor - Wall-mount, black plastic case, no display, rated for plenum mounting	C0SNSR53AE1L	87N54	X	X	X	X	X	X	X	X
CO <sub>2</sub> Sensor Duct Mounting Kit - for downflow applications	C0MISC19AE1-	85L43	X	X	X	X	X	X	X	X
Aspiration Box - for duct mounting non-plenum rated CO <sub>2</sub> sensor (77N39)	C0MISC16AE1-	90N43	X	X	X	X	X	X	X	X

### UVC Germicidal Lamps

<sup>2</sup> Healthy Climate® UVC Light Kit (208/230v-1ph)	E1UVCL10AN1-	50W90	X	X	X	X	X	X	X	X
--	--------------	-------	---	---	---	---	---	---	---	---

<sup>1</sup> KCB models only.

<sup>2</sup> Lamps operate on 110-230V single-phase power supply. Step-down transformer may be ordered separately for 460V and 575V units. Alternately, 110V power supply may be used to directly power the UVC ballast(s).

NOTE - The catalog and model numbers that appear here are for ordering field installed accessories only.

OX - Field Installed or Configure to Order (factory installed)

O - Configure to Order (Factory Installed)

X - Field Installed.

## OPTIONS / ACCESSORIES - KCA/KCB

Item	Model No.	Catalog No.	Unit Model No.							
			KCB 024	KCB 030	KCA 036	KCA 048	KCA 060	KCA 072	KCB 074	KCA 090
<b>CEILING DIFFUSERS</b>										
Step-Down - Order one	RTD9-65S	<b>13K60</b>	X	X	X	X	X			
	RTD11-95S	<b>13K61</b>						X	X	X
Flush - Order one	FD9-65S	<b>13K55</b>	X	X	X	X	X			
	FD11-95S	<b>13K56</b>						X	X	X
Transitions (Supply and Return) - Order one	T1TRAN10AN1	<b>17W53</b>	X	X	X	X	X			
	T1TRAN20N-1	<b>17W54</b>						X	X	X
<b>ROOF CURBS</b>										
<b>Hybrid Roof Curbs, Downflow</b>										
8 in. height	C1CURB70A-1	<b>11F50</b>	X	X	X	X	X	X	X	<sup>1</sup> X
14 in. height	C1CURB71A-1	<b>11F51</b>	X	X	X	X	X	X	X	<sup>1</sup> X
18 in. height	C1CURB72A-1	<b>11F52</b>	X	X	X	X	X	X	X	<sup>1</sup> X
24 in. height	C1CURB73A-1	<b>11F53</b>	X	X	X	X	X	X	X	<sup>1</sup> X
<b>Hybrid Roof Curbs, Full Perimeter, Downflow</b>										
8 in. height	K1CURB70AP1	<b>11S47</b>								X
14 in. height	K1CURB71AP1	<b>11S48</b>								X
18 in. height	K1CURB72AP1	<b>11T01</b>								X
24 in. height	K1CURB73AP1	<b>11T06</b>								X
<b>Adjustable Pitch Curb</b>										
14 in. height	C1CURB55AT1	<b>43W27</b>	X	X	X	X	X	X	X	<sup>1</sup> X

<sup>1</sup> 090 models will fit smaller roof curbs with overhang. See dimension drawing.

NOTE - The catalog and model numbers that appear here are for ordering field installed accessories only.

OX - Field Installed or Configure to Order (factory installed)

O - Configure to Order (Factory Installed)

X - Field Installed.

## OPTIONS / ACCESSORIES - KCA ONLY

Item	Model No.	Catalog No.	Unit Model No.				
			KCA 036	KCA 048	KCA 060	KCA 072	KCA 090
<b>COOLING SYSTEM</b>							
Compressor Crankcase Heater	208/230V-1 or 3ph - K1CCHT02A-2P	14D86	X	X			
	208/230V-1 or 3ph - T1CCHT01AN2P	14D83			X		
	460V-3ph - K1CCHT012A-2G	14D87	X	X			
	460V-3ph - T1CCHT01AN2G	14D84			X		
	575V-3ph - K1CCHT02A-2J	14D88	X	X			
	575V-3ph - T1CCHT01AN2J	14D85			X		

<b>CABINET</b>							
Combination Coil/Hail Guards	C1GARD51A-1	13R98	X	X	X		
	C1GARD51AT1	13T03				X	
	K1GARD50AP1	13T17					X

<b>CONTROLS</b>							
BACnet®	K0CTRL31A-1	96W14	OX	OX	OX		
	K0CTRL31AP1	12B99				OX	OX
Novar® 2051	K0CTRL30A-1	96W11	OX	OX	OX		
	K0CTRL30AP1	12B98				OX	OX

## INDOOR AIR QUALITY

### Air Filters

Healthy Climate® High Efficiency Air Filters	MERV 8 (16 x 20 x 2) - C1FLTR15A-1-	54W20	X	X	X		
	MERV 13 (16 x 20 x 2) - T1FLTR40A-1-	52W37	X	X	X		
Order 4 per unit	MERV 8 (20 x 20 x 2) - C1FLTR15D-1-	54W21				X	X
	MERV 13 (20 x 20 x 2) - C1FLTR40D-1-	52W39				X	X

NOTE - The catalog and model numbers that appear here are for ordering field installed accessories only.

OX - Field Installed or Configure to Order (factory installed)

O - Configure to Order (Factory Installed)

X - Field Installed.

## OPTIONS / ACCESSORIES - KCB ONLY

Item	Model No.	Catalog No.	Unit Model No.						
			KCB 024	KCB 030	KCB 036	KCB 048	KCB 060	KCB 072	KCB 074
<b>CABINET</b>									
Combination Coil/Hail Guards	C1GARD51A-1	13R98	X	X	X	X			
	C1GARD51AT1	13T03					X	X	
<b>CONTROLS</b>									
BACnet®	K0CTRL31A-1	96W14	OX	OX	OX	OX			
	K0CTRL31AP1	12B99					OX	OX	
Novar® 2051	K0CTRL30A-1	96W11	OX	OX	OX	OX			
	K0CTRL30AP1	12B98					OX	OX	

## INDOOR AIR QUALITY

### Air Filters

Healthy Climate® High Efficiency Air Filters	MERV 8 (16 x 20 x 2) - C1FLTR15A-1-	54W20	X	X	X	X		
	MERV 13 (16 x 20 x 2) - T1FLTR40A-1-	52W37	X	X	X	X		
Order 4 per unit	MERV 8 (20 x 20 x 2) - C1FLTR15D-1-	54W21					X	X
	MERV 13 (20 x 20 x 2) - C1FLTR40D-1-	52W39					X	X

NOTE - The catalog and model numbers that appear here are for ordering field installed accessories only.

OX - Field Installed or Configure to Order (factory installed)

O - Configure to Order (Factory Installed)

X - Field Installed.

**SPECIFICATIONS - DIRECT DRIVE BLOWER - KCB****2 - 2.5 TON**

General Data		Nominal Tonnage	2 Ton	2.5 Ton
		Model No.	KCB024S4D	KCB030S4D
		Efficiency Type	Standard	Standard
		Blower Type	Multi-Speed Direct Drive	Multi-Speed Direct Drive
<b>Cooling Performance</b>	Gross Cooling Capacity - Btuh		24,800	31,200
	<sup>1</sup> Net Cooling Capacity - Btuh		24,200	30,200
	AHRI Rated Air Flow - cfm		840	1010
	<sup>2</sup> Sound Rating Number (SRN) ((dBA)		74	74
	Total Unit Power - kW		1.9	2.4
	<sup>1</sup> SEER (Btuh/Watt)		14.0	14.0
	<sup>1</sup> EER (Btuh/Watt)		12.7	11.55
<b>Refrigerant</b>	Type		R-410A	R-410A
	Charge Furnished		4 lbs. 3 oz.	5 lbs. 1 oz.
<b>Electric Heat Available - See page 11</b>			5, 7.5, 10 kW	5, 7.5, 10 kW
<b>Compressor Type (one per unit)</b>			Scroll	Scroll
<b>Outdoor Coil</b>	Net face area - sq. ft.		11.7	11.7
	Number of rows		1	1
	Fins per inch		23	23
<b>Outdoor Coil Fan</b>	Motor - (No.) HP		(1) 1/4	(1) 1/4
	Motor rpm		825	825
	Total Motor Input - watts		250	250
	Diameter - (No.) in. / No. of blades		(1) 24 - 3	(1) 24 - 3
	Total air volume - cfm		3100	3100
<b>Indoor Coil</b>	Net face area - sq. ft.		7.8	7.8
	Tube diameter - in.		3/8	3/8
	Number of rows		2	3
	Fins per inch		14	14
	Drain Connection (no.) and size - in.		(1) 1 NPT	(1) 1 NPT
	Expansion device type		Balanced Port Thermostatic Expansion Valve, removable power head	
<b>Indoor Blower</b>	Nominal Motor HP		0.25 hp	0.25 hp
	Wheel nominal diameter x width - in.		(1) 10 x 10	(1) 10 x 10
<b>Filters</b>	Type		Disposable	
	Number and size - in.		(4) 16 x 20 x 2	
<b>Electrical Characteristics - 60 Hz</b>			208/230V 1 phase	208/230V 1 phase

NOTE - Net capacity includes evaporator blower motor heat deduction. Gross capacity does not include evaporator blower motor heat deduction.

<sup>1</sup> AHRI Certified to AHRI Standard 210/240: 95°F outdoor air temperature and 80°F db/67°F wb entering evaporator air; minimum external duct static pressure.<sup>2</sup> Sound Rating Number (SRN) rated in accordance with test conditions included in ARI Standard 270-95.

**SPECIFICATIONS - DIRECT DRIVE BLOWER - KCB**
**3 - 5 TON**

General Data		Nominal Tonnage	3 Ton	4 Ton	5 Ton
		Model No.	KCB036S4D	KCB048S4D	KCB060S4D
		Efficiency Type	Standard	Standard	Standard
		Blower Type	Multi-Speed Direct Drive	Multi-Speed Direct Drive	Multi-Speed Direct Drive
<b>Cooling Performance</b>	Gross Cooling Capacity - Btuh		38,500	49,700	61,900
	<sup>1</sup> Net Cooling Capacity - Btuh		37,200	47,500	59,500
	AHRI Rated Air Flow - cfm		1140	1600	1760
	<sup>2</sup> Sound Rating Number (SRN)(dBA)		74	74	79
	Total Unit Power - kW		2.9	4.1	5.0
	<sup>1</sup> SEER (Btuh/Watt)		14.0	14.0	14.0
	<sup>1</sup> EER (Btuh/Watt)		12.5	11.5	11.8
<b>Refrigerant</b>	Type		R-410A	R-410A	R-410A
	Charge Furnished		5 lbs. 9 oz.	5 lbs. 6 oz.	6 lbs. 13 oz.
<b>Electric Heat Available - See page 11</b>			7.5, 15 kW	7.5, 15 kW	7.5, 15, 22.5 kW
<b>Compressor Type (one per unit)</b>			Scroll	Scroll	Scroll
<b>Outdoor Coil</b>	Net face area - sq. ft.		14.5	14.5	17.8
	Number of rows		1	1	1
	Fins per inch		23	23	23
<b>Outdoor Coil Fan</b>	Motor - (No.) HP		(1) 1/4	(1) 1/4	(1) 1/3
	Motor rpm		825	825	1075
	Total Motor Input - watts		250	250	370
	Diameter - (No.) in. / No. of blades		(1) 24 - 3	(1) 24 - 3	(1) 24 - 3
	Total air volume - cfm		3300	3300	4700
<b>Indoor Coil</b>	Net face area - sq. ft.		7.8	7.8	9.7
	Tube diameter - in.		3/8	3/8	3/8
	Number of rows		3	3	4
	Fins per inch		14	14	14
	Drain Connection (no.) and size - in.		(1) 1 NPT	(1) 1 NPT	(1) 1 NPT
	Expansion device type		Balanced Port Thermostatic Expansion Valve, removable power head		
<b>Indoor Blower</b>	Nominal Motor HP		0.5 hp	0.5 hp	0.75 hp
	Wheel nominal diameter x width - in.		(1) 10 x 10	(1) 10 x 10	(1) 11 x 10
<b>Filters</b>	Type		Disposable		
	Number and size - in.		(4) 16 x 20 x 2		(4) 20 x 20 x 2
<b>Electrical Characteristics - 60 Hz</b>			208/230V 1 phase	208/230V 1 phase	208/230V 1 phase
			208/230V, 460V & 575V 3 phase	208/230V, 460V & 575V 3 phase	208/230V, 460V & 575V 3 phase

NOTE - Net capacity includes evaporator blower motor heat deduction. Gross capacity does not include evaporator blower motor heat deduction.

<sup>1</sup> AHRI Certified to AHRI Standard 210/240: 95°F outdoor air temperature and 80°F db/67°F wb entering evaporator air; minimum external duct static pressure.

<sup>2</sup> Sound Rating Number (SRN) rated in accordance with test conditions included in ARI Standard 270-95.

**SPECIFICATIONS - BELT DRIVE BLOWER - KCB**
**3 - 5 TON**

General Data		Nominal Tonnage	3 Ton	4 Ton	5 Ton		
		Model No.	KCB036S4B	KCB048S4B	KCB060S4B		
		Efficiency Type	Standard	Standard	Standard		
		Blower Type	Single Speed Belt Drive	Single Speed Belt Drive	Single Speed Belt Drive		
<b>Cooling Performance</b>	Gross Cooling Capacity - Btuh		38,500	49,700	61,900		
	<sup>1</sup> Net Cooling Capacity - Btuh		37,200	47,500	59,500		
	AHRI Rated Air Flow - cfm		1140	1600	1760		
	<sup>2</sup> Sound Rating Number (SRN) (dBA)		74	74	79		
	Total Unit Power - kW		2.9	4.1	5		
	<sup>1</sup> SEER (Btuh/Watt)		14.0	14.0	14.0		
	<sup>1</sup> EER (Btuh/Watt)		12.5	11.5	11.8		
<b>Refrigerant</b>	Type		R-410A	R-410A	R-410A		
	Charge Furnished		5 lbs. 9 oz.	5 lbs. 6 oz.	6 lbs. 13 oz.		
<b>Electric Heat Available - See page 11</b>			7.5, 15 kW	7.5, 15 kW	7.5, 15, 22.5 kW		
<b>Compressor Type (one per unit)</b>			Scroll	Scroll	Scroll		
<b>Outdoor Coil</b>	Net face area - sq. ft.		14.5	14.5	17.8		
	Number of rows		1	1	1		
	Fins / inch		23	23	23		
<b>Outdoor Coil Fan</b>	Motor - (No.) HP		(1) 1/4	(1) 1/4	(1) 1/3		
	Motor rpm		825	825	1075		
	Total Motor Input - watts		250	250	370		
	Diameter - (No.) in. / No. of blades		(1) 24 - 3	(1) 24 - 3	(1) 24 - 3		
	Total air volume - cfm		3300	3300	4700		
<b>Indoor Coil</b>	Net face area - sq. ft.		7.8	7.8	9.7		
	Tube diameter - in.		3/8	3/8	3/8		
	Number of rows		3	3	4		
	Fins per inch		14	14	14		
	Drain Connection (no.) and size - in.		(1) 1 NPT	(1) 1 NPT	(1) 1 NPT		
	Expansion device type		Balanced Port Thermostatic Expansion Valve, removable power head				
<sup>3</sup> <b>Indoor Blower &amp; Drive Selection</b>	Nominal Motor HP	208/230V-1ph	0.75 hp, 1.5 hp	0.75 hp, 1.5 hp	0.75 hp, 1.5 hp		
		All others voltages	1 hp, 2 hp	1 hp, 2 hp	1 hp, 2 hp		
	Maximum Usable Motor HP	208/230V-1ph	0.86 hp, 1.7 hp	0.86 hp, 1.7 hp	0.86 hp, 1.7 hp		
		All other voltages	1.15 hp, 2.3 hp	1.15 hp, 2.3 hp	1.15 hp, 2.3 hp		
	Available Drive Kits	A01	673 - 1010 rpm	A02	745 - 1117 rpm	A03	833 - 1250 rpm
		A05	897 - 1346 rpm	A06	1071 - 1429 rpm	A07	1212 - 1548 rpm
Wheel nominal diameter x width - in.		(1) 10 x 10	(1) 10 x 10	(1) 10 x 10			
<b>Filters</b>	Type	Disposable					
	Number and size - in.	(4) 16 x 20 x 2		(4) 20 x 20 x 2			
<b>Electrical Characteristics - 60 Hz</b>		208/230V 1 phase	208/230V, 1 phase	208/230V 1 phase			
		208/230V, 460V & 575V 3 phase	208/230V 460V & 575V 3 phase	208/230V 460V & 575V 3 phase			

NOTE - Net capacity includes evaporator blower motor heat deduction. Gross capacity does not include evaporator blower motor heat deduction.

<sup>1</sup> AHRI Certified to AHRI Standard 210/240: 95°F outdoor air temperature and 80°F db/67°F wb entering evaporator air; minimum external duct static pressure.

<sup>2</sup> Sound Rating Number (SRN) rated in accordance with test conditions included in ARI Standard 270-95.

<sup>3</sup> Using total air volume and system static pressure requirements determine from blower performance tables rpm and motor hp required. Maximum usable hp of motors furnished are shown. In Canada, nominal motor hp is also maximum usable motor hp output. If motors of comparable hp are used, be sure to keep within the service factor limitations outlined on the motor nameplate.



**SPECIFICATIONS - BELT DRIVE BLOWER - KCB**
**6 TON**

General Data		Nominal Tonnage	6 Ton	6 Ton	6 Ton	
		Model No.	KCB072H4B	KCB074H4T	KCB074S4T	
		Efficiency Type	High	High	Standard	
		Blower Type	Single Speed Belt Drive	Two-Speed Belt Drive	Two-Speed Belt Drive	
<b>Cooling Performance</b>	Gross Cooling Capacity - Btuh		73,500	72,000	71,000	
	<sup>1</sup> Net Cooling Capacity - Btuh		72,000	69,000	68,000	
	AHRI Rated Air Flow - cfm		1920	2100	2100	
	<sup>2</sup> Sound Rating Number (SRN) (dBA)		79	79	79	
	Total Unit Power - kW		6.0	5.7	6.1	
	<sup>1</sup> IEER		13.5	16.0	15.0	
	<sup>1</sup> EER (Btuh/Watt)		12.0	12.0	11.2	
<b>Refrigerant</b>	Type		R-410A	R-410A	R-410A	
	Charge Furnished		7 lbs. 8 oz.	7 lbs. 2 oz.	7 lbs. 2 oz.	
<b>Electric Heat Available - See page 11</b>			7.5, 15, 22.5, 30 kW	7.5, 15, 22.5, 30 kW	7.5, 15, 22.5, 30 kW	
<b>Compressor Type (one per unit)</b>			Scroll	Two-Stage Scroll	Two-Stage Scroll	
<b>Outdoor Coil</b>	Net face area - sq. ft.		17.8	17.8	17.8	
	Number of rows		1	1	1	
	Fins / inch		23	23	23	
<b>Outdoor Coil Fan</b>	Motor - (No.) HP		(1) 1/3	(1) 1/3	(1) 1/3	
	Motor rpm		1075	1075	1075	
	Total Motor Input - watts		410	375	375	
	Diameter - (No.) in. / No. of blades		(1) 24 - 3	(1) 24 - 3	(1) 24 - 3	
	Total air volume - cfm		4800	4700	4700	
<b>Indoor Coil</b>	Net face area - sq. ft.		9.72	9.72	9.72	
	Tube diameter - in.		3/8	3/8	3/8	
	Number of rows		4	4	4	
	Fins per inch		14	14	14	
	Drain Connection (no.) and size - in.		(1) 1 in. NPT	(1) 1 in. NPT	(1) 1 in. NPT	
	Expansion device type		Balanced Port Thermostatic Expansion Valve, removable power head			
<sup>3</sup> <b>Indoor Blower &amp; Drive Selection</b>	Nominal Motor Output		1 hp, 2 hp	1 hp, 2 hp	1 hp, 2 hp	
	Maximum Usable Motor Output (US Only)		1.15 hp, 2.3 hp	1.15 hp, 2.3 hp	1.15 hp, 2.3 hp	
	Motor - Drive Kit Number	AA01		AA01	AA01	A04
		522-784 rpm		522-784 rpm	522-784 rpm	968 - 1340 rpm
		AA02		AA02	AA02	A08
		632-875 rpm		632-875 rpm	632-875 rpm	1193-1591 rpm
	AA03		AA03	AA03		
798-1105 rpm		798-1105 rpm	798-1105 rpm			
Wheel Nominal Diameter x Width - in.		(1) 15 x 9	(1) 15 x 9	(1) 10 x 10		
<b>Filters</b>	Type		Disposable			
	Number and size - in.		(4) 20 x 20 x 2	(4) 20 x 20 x 2	(4) 20 x 20 x 2	
<b>Electrical Characteristics - 60 Hz</b>			208/230V, 460V or 575V - 60 hertz - 3 phase			

NOTE - Net capacity includes evaporator blower motor heat deduction. Gross capacity does not include evaporator blower motor heat deduction.

<sup>1</sup> AHRI Certified to AHRI Standard 340/360: 95°F outdoor air temperature and 80°F db/67°F wb entering evaporator air; minimum external duct static pressure.

<sup>2</sup> Sound Rating Number (SRN) rated in accordance with test conditions included in ARI Standard 270-95.

<sup>3</sup> Using total air volume and system static pressure requirements determine from blower performance tables rpm and motor hp required. Maximum usable hp of motors furnished are shown. In Canada, nominal motor hp is also maximum usable motor hp output. If motors of comparable hp are used, be sure to keep within the service factor limitations outlined on the motor nameplate.

**SPECIFICATIONS - DIRECT DRIVE BLOWER- KCA**
**3 - 5 TON**

General Data		Nominal Tonnage	3 Ton	4 Ton	5 Ton
		Model No.	KCA036S4D	KCA048S4D	KCA060S4D
		Efficiency Type	Standard	Standard	Standard
		Blower Type	Multi-Speed Direct Drive	Multi-Speed Direct Drive	Multi-Speed Direct Drive
<b>Cooling Performance</b>	Gross Cooling Capacity - Btuh		37,500	50,000	61,800
	<sup>1</sup> Net Cooling Capacity - Btuh		36,000	48,000	59,000
	AHRI Rated Air Flow - cfm		1200	1600	1800
	<sup>2</sup> Sound Rating Number (SRN)((dBA)		75	75	82
	Total Unit Power - kW		3.4	4.4	5.3
	<sup>1</sup> SEER (Btuh/Watt)		13.0	13.0	13.0
	<sup>1</sup> EER (Btuh/Watt)		10.7	11.0	11.2
<b>Refrigerant</b>	Type		R-410A	R-410A	R-410A
	Charge Furnished		7 lbs. 12 oz.	8 lbs. 12 oz.	12 lbs. 8 oz.
<b>Electric Heat Available - See page 11</b>			7.5, 15 kW	7.5, 15 kW	7.5, 15, 22.5 kW
<b>Compressor Type (one per unit)</b>			Scroll	Scroll	Scroll
<b>Outdoor Coil</b>	Net face area - sq. ft.		15.6	15.6	15.6
	Tube diameter - in.		(1) 3/8	(1) 3/8	(1) 3/8
	Number of rows		1	1.5	2
	Fins per inch		20	20	20
<b>Outdoor Coil Fan</b>	Motor - (No.) HP		1/4	1/4	1/3
	Motor rpm		825	825	1075
	Total Motor Input - watts		250	250	370
	Diameter - (No.) in. / No. of blades		(1) 24 - 3	(1) 24 - 3	(1) 24 - 3
	Total air volume - cfm		3700	3500	4300
<b>Indoor Coil</b>	Net face area - sq. ft.		7.8	7.8	7.8
	Tube diameter - in.		3/8	3/8	3/8
	Number of rows		3	3	4
	Fins per inch		14	14	14
	Drain Connection (no.) and size - in.		(1) 1 NPT	(1) 1 NPT	(1) 1 NPT
	Expansion device type		Refrigerant Metering Orifice (RFC)		
<b>Indoor Blower</b>	Nominal Motor HP		0.5 hp	0.5 hp	0.75 hp
	Wheel nominal diameter x width - in.		(1) 10 x 10	(1) 10 x 10	(1) 11 x 10
<b>Filters</b>	Type		Disposable		
	Number and size - in.		(4) 16 x 20 x 2		
<b>Electrical Characteristics - 60 Hz</b>			208/230V, 460V & 575V 3 phase	208/230V, 460V & 575V 3 phase	208/230V, 460V & 575V 3 phase

NOTE - Net capacity includes evaporator blower motor heat deduction. Gross capacity does not include evaporator blower motor heat deduction.

<sup>1</sup> AHRI Certified to AHRI Standard 210/240: 95°F outdoor air temperature and 80°F db/67°F wb entering evaporator air; minimum external duct static pressure.

<sup>2</sup> Sound Rating Number (SRN) rated in accordance with test conditions included in ARI Standard 270-95.

**SPECIFICATIONS - BELT DRIVE BLOWER - KCA**

**3 - 7.5 TON**

General Data		Nominal Tonnage	3 Ton	4 Ton	5 Ton	6 Ton	7.5 Ton
		Model No.	KCA036S4B	KCA048S4B	KCA060S4B	KCA072S4B	KCA090S4B
		Efficiency Type	Standard	Standard	Standard	Standard	Standard
		Blower Type	Single Speed Belt Drive	Single Speed Belt Drive	Single Speed Belt Drive	Single Speed Belt Drive	Single Speed Belt Drive
<b>Cooling Performance</b>	Gross Cooling Capacity - Btuh		37,500	50,000	61,800	72,500	92,000
	Net Cooling Capacity - Btuh		<sup>1</sup> 36,000	<sup>1</sup> 48,000	<sup>1</sup> 59,000	69,000	<sup>2</sup> 90,000
	AHRI Rated Air Flow - cfm		1200	1600	1800	2450	2430
	<sup>3</sup> Sound Rating Number (SRN) (dBA)		75	75	82	79	79
	Total Unit Power - kW		3.4	4.4	5.3	6.1	8.2
	SEER (Btuh/Watt)		<sup>1</sup> 13.0	<sup>1</sup> 13.0	<sup>1</sup> 13.0	---	---
	IEER (Btuh/Watt)		---	---	---	<sup>2</sup> 12.3	<sup>2</sup> 11.4
	EER (Btuh/Watt)		<sup>1</sup> 10.7	<sup>1</sup> 11.0	<sup>1</sup> 11.2	<sup>2</sup> 11.2	<sup>2</sup> 11.2
<b>Refrigerant</b>	Type		R-410A	R-410A	R-410A	R-410A	R-410A
	Charge Furnished		7 lbs. 12 oz.	8 lbs. 12 oz.	12 lbs. 8 oz.	7 lbs. 1 oz.	8 lbs. 8 oz.
<b>Electric Heat Available - See page 11</b>			7.5, 15 kW	7.5, 15 kW	7.5, 15, 22.5 kW	7.5, 15, 22.5, 30 kW	
<b>Compressor Type (one per unit)</b>			Scroll	Scroll	Scroll	Scroll	Scroll
<b>Outdoor Coil</b>	Net face area - sq. ft.		15.6	15.6	15.6	17.8	24.2
	Tube diameter - in.		3/8	3/8	3/8	---	---
	Number of rows		1	1.5	2	1	1
	Fins / inch		20	20	20	23	23
<b>Outdoor Coil Fan</b>	Motor - (No.) HP		(1) 1/4	(1) 1/4	(1) 1/3	(1) 1/3	(1) 1/2
	Motor rpm		825	825	1075	1075	1075
	Total Motor Input - watts		250	250	370	370	520
	Diameter - (No.) in. / No. of blades		(1) 24 - 3	(1) 24 - 3	(1) 24 - 3	(1) 24 - 3	(1) 24 - 4
	Total air volume - cfm		3700	3500	4300	4700	5300
<b>Indoor Coil</b>	Net face area - sq. ft.		7.8	7.8	7.8	9.7	9.7
	Tube diameter - in.		3/8	3/8	3/8	3/8	3/8
	Number of rows		3	3	4	4	4
	Fins per inch		14	14	14	14	14
	Drain Connection (no.) and size - in.		(1) 1 NPT	(1) 1 NPT	(1) 1 NPT	(1) 1 NPT	(1) 1 NPT
Expansion device type			Refrigerant Metering Orifice (RFC)				
<b><sup>4</sup> Indoor Blower &amp; Drive Selection</b>	Nominal Motor HP		1 hp, 2 hp	1 hp, 2 hp	1 hp, 2 hp	1 hp, 2 hp	1 hp
	Maximum Usable Motor HP		1.15 hp, 2.3 hp	1.15 hp, 2.3 hp	1.15 hp, 2.3 hp	1.15 hp, 2.3 hp	1.15 hp
	Available Drive Kits		A01	A02	A03	A04	AA01
			673 - 1010 rpm	745 - 1117 rpm	833 - 1250 rpm	968 - 1340 rpm	522 - 784 rpm
			A05	A06	A07	A08	
			897 - 1346 rpm	1071 - 1429 rpm	1212 - 1548 rpm	1193 - 1591 rpm	
	Nominal Motor HP		---	---	---	---	2 hp
	Maximum Usable Motor HP		---	---	---	---	2.3 hp
	Available Drive Kits		---	---	---	---	AA02
							632 - 875 rpm
						AA03	
						798 - 1105 rpm	
						3 hp	
						3.45 hp	
						AA04	
						921 - 1228 rpm	
Wheel nominal diameter x width - in.			(1) 10 x 10	(1) 10 x 10	(1) 10 x 10	(1) 10 x 10	(1) 15 x 9
<b>Filters</b>	Type		Disposable			Disposable	
	Number and size - in.		(4) 16 x 20 x 2			(4) 20 x 20 x 2	
<b>Electrical Characteristics - 60 Hz</b>			208/230V, 460V & 575V 3 phase	208/230V, 460V & 575V 3 phase	208/230V, 460V & 575V 3 phase	208/230V, 460V & 575V 3 phase	208/230V, 460V & 575V 3 phase

NOTE - Net capacity includes evaporator blower motor heat deduction. Gross capacity does not include evaporator blower motor heat deduction.

<sup>1,2</sup> AHRI Certified to AHRI Standard <sup>1</sup> 210/240 or <sup>2</sup> 340/360: 95°F outdoor air temperature and 80°F db/67°F wb entering evaporator air; minimum external duct static pressure.

<sup>3</sup> Sound Rating Number (SRN) rated in accordance with test conditions included in ARI Standard 270-95.

<sup>4</sup> Using total air volume and system static pressure requirements determine from blower performance tables rpm and motor hp required. Maximum usable hp of motors furnished are shown. In Canada, nominal motor hp is also maximum usable motor hp output. If motors of comparable hp are used, be sure to keep within the service factor limitations outlined on the motor nameplate.

## RATINGS - KCA

NOTE - For Temperatures and Capacities not shown in tables, see bulletin - Cooling Unit Rating Table Correction Factor Data in Miscellaneous Engineering Data section.

### 3 TON - KCA036S4

Entering Wet Bulb Temperature	Total Air Volume	Outdoor Air Temperature Entering Outdoor Coil																			
		85°F					95°F					105°F					115°F				
		Total Cool Cap.	Comp. Motor Input	Sensible To Total Ratio (S/T)			Total Cool Cap.	Comp. Motor Input	Sensible To Total Ratio (S/T)			Total Cool Cap.	Comp. Motor Input	Sensible To Total Ratio (S/T)			Total Cool Cap.	Comp. Motor Input	Sensible To Total Ratio (S/T)		
				Dry Bulb					Dry Bulb					Dry Bulb					Dry Bulb		
cfm	kBtuh	kW	75°F	80°F	85°F	kBtuh	kW	75°F	80°F	85°F	kBtuh	kW	75°F	80°F	85°F	kBtuh	kW	75°F	80°F	85°F	
63°F	960	35.6	2.35	0.75	0.87	0.98	33.4	2.67	0.75	0.89	1	31.1	3.04	0.77	0.91	1	28.5	3.48	0.79	0.93	1
	1200	37.7	2.36	0.8	0.93	1	35.3	2.68	0.81	0.95	1	32.9	3.06	0.82	0.98	1	30.2	3.49	0.84	1	1
	1440	39.3	2.37	0.84	0.98	1	36.8	2.69	0.85	1	1	34.5	3.07	0.87	1	1	32	3.5	0.9	1	1
67°F	960	37.6	2.36	0.59	0.72	0.84	35.4	2.68	0.59	0.73	0.86	33.1	3.05	0.59	0.74	0.88	30.4	3.5	0.59	0.76	0.9
	1200	39.8	2.38	0.62	0.78	0.91	37.5	2.7	0.62	0.79	0.92	34.9	3.07	0.63	0.8	0.94	32.1	3.5	0.64	0.82	0.97
	1440	41.4	2.39	0.65	0.82	0.96	38.9	2.71	0.66	0.84	0.98	36.2	3.08	0.66	0.86	1	33.3	3.51	0.68	0.88	1
71°F	960	39.9	2.38	0.45	0.58	0.7	37.5	2.7	0.44	0.58	0.71	34.9	3.07	0.42	0.58	0.72	32.2	3.5	0.43	0.58	0.74
	1200	42	2.39	0.45	0.61	0.75	39.5	2.71	0.46	0.61	0.77	36.9	3.09	0.45	0.62	0.79	34	3.52	0.45	0.63	0.81
	1440	43.6	2.41	0.47	0.65	0.8	41	2.73	0.46	0.65	0.82	38.2	3.1	0.47	0.66	0.83	35.2	3.53	0.47	0.68	0.87

### 4 TON - KCA048S4

Entering Wet Bulb Temperature	Total Air Volume	Outdoor Air Temperature Entering Outdoor Coil																			
		85°F					95°F					105°F					115°F				
		Total Cool Cap.	Comp. Motor Input	Sensible To Total Ratio (S/T)			Total Cool Cap.	Comp. Motor Input	Sensible To Total Ratio (S/T)			Total Cool Cap.	Comp. Motor Input	Sensible To Total Ratio (S/T)			Total Cool Cap.	Comp. Motor Input	Sensible To Total Ratio (S/T)		
				Dry Bulb					Dry Bulb					Dry Bulb					Dry Bulb		
cfm	kBtuh	kW	75°F	80°F	85°F	kBtuh	kW	75°F	80°F	85°F	kBtuh	kW	75°F	80°F	85°F	kBtuh	kW	75°F	80°F	85°F	
63°F	1280	47.6	3.02	0.74	0.87	0.98	44.5	3.44	0.74	0.88	1	41.2	3.89	0.75	0.9	1	37.8	4.41	0.77	0.93	1
	1600	50.4	3.04	0.79	0.93	1	47.1	3.46	0.8	0.95	1	43.7	3.91	0.81	0.97	1	40	4.42	0.83	1	1
	1920	52.6	3.05	0.83	0.99	1	49.1	3.47	0.85	1	1	45.7	3.93	0.87	1	1	42.3	4.45	0.89	1	1
67°F	1280	50.6	3.04	0.58	0.72	0.84	47.2	3.45	0.58	0.72	0.85	43.9	3.91	0.57	0.73	0.87	40.3	4.44	0.57	0.74	0.9
	1600	53.5	3.06	0.61	0.77	0.9	50	3.48	0.61	0.78	0.92	46.4	3.94	0.62	0.8	0.95	42.5	4.45	0.62	0.81	0.98
	1920	55.6	3.07	0.64	0.82	0.96	51.9	3.5	0.65	0.83	0.98	47.9	3.95	0.66	0.85	1	44	4.47	0.67	0.88	1
71°F	1280	53.7	3.06	0.43	0.57	0.69	50.2	3.48	0.43	0.57	0.7	46.6	3.93	0.42	0.57	0.71	42.8	4.46	0.41	0.57	0.72
	1600	56.4	3.07	0.45	0.6	0.75	52.6	3.5	0.45	0.6	0.76	49	3.96	0.44	0.61	0.78	45	4.48	0.43	0.62	0.8
	1920	58.6	3.08	0.47	0.64	0.8	54.8	3.52	0.47	0.64	0.81	50.8	3.98	0.46	0.65	0.83	46.7	4.5	0.45	0.66	0.86

### 5 TON - KCA060S4

Entering Wet Bulb Temperature	Total Air Volume	Outdoor Air Temperature Entering Outdoor Coil																			
		85°F					95°F					105°F					115°F				
		Total Cool Cap.	Comp. Motor Input	Sensible To Total Ratio (S/T)			Total Cool Cap.	Comp. Motor Input	Sensible To Total Ratio (S/T)			Total Cool Cap.	Comp. Motor Input	Sensible To Total Ratio (S/T)			Total Cool Cap.	Comp. Motor Input	Sensible To Total Ratio (S/T)		
				Dry Bulb					Dry Bulb					Dry Bulb					Dry Bulb		
cfm	kBtuh	kW	75°F	80°F	85°F	kBtuh	kW	75°F	80°F	85°F	kBtuh	kW	75°F	80°F	85°F	kBtuh	kW	75°F	80°F	85°F	
63°F	1600	60.1	3.48	0.68	0.84	1	57	3.93	0.69	0.86	1	53.5	4.44	0.71	0.89	1	50	5.04	0.73	0.93	1
	2000	63.1	3.51	0.74	0.94	1	59.8	3.96	0.76	0.97	1	56	4.47	0.78	1	1	52.6	5.06	0.81	1	1
	2400	65.6	3.54	0.8	1	1	62.3	3.99	0.83	1	1	59.1	4.51	0.86	1	1	55.6	5.1	0.91	1	1
67°F	1600	63.9	3.52	0.54	0.66	0.79	60.5	3.97	0.54	0.67	0.82	57.1	4.48	0.55	0.69	0.85	53.2	5.07	0.56	0.71	0.89
	2000	66.8	3.55	0.57	0.72	0.9	63.1	4	0.58	0.73	0.93	59.2	4.51	0.58	0.75	0.97	55.1	5.1	0.59	0.79	1
	2400	68.9	3.58	0.6	0.78	0.99	65	4.02	0.61	0.8	1	61.1	4.54	0.63	0.84	1	56.8	5.12	0.64	0.88	1
71°F	1600	67.7	3.56	0.4	0.52	0.64	64.2	4.01	0.41	0.53	0.65	60.4	4.53	0.4	0.54	0.67	56.4	5.12	0.4	0.54	0.69
	2000	70.7	3.6	0.42	0.56	0.7	67	4.05	0.42	0.57	0.71	62.8	4.56	0.42	0.57	0.73	58.5	5.15	0.42	0.59	0.76
	2400	72.7	3.62	0.43	0.59	0.75	68.7	4.07	0.43	0.6	0.78	64.6	4.58	0.44	0.62	0.81	60	5.17	0.44	0.64	0.85

### 6 TON - KCA072S4

Entering Wet Bulb Temperature	Total Air Volume	Outdoor Air Temperature Entering Outdoor Coil																			
		85°F					95°F					105°F					115°F				
		Total Cool Cap.	Comp. Motor Input	Sensible To Total Ratio (S/T)			Total Cool Cap.	Comp. Motor Input	Sensible To Total Ratio (S/T)			Total Cool Cap.	Comp. Motor Input	Sensible To Total Ratio (S/T)			Total Cool Cap.	Comp. Motor Input	Sensible To Total Ratio (S/T)		
				Dry Bulb					Dry Bulb					Dry Bulb					Dry Bulb		
cfm	kBtuh	kW	75°F	80°F	85°F	kBtuh	kW	75°F	80°F	85°F	kBtuh	kW	75°F	80°F	85°F	kBtuh	kW	75°F	80°F	85°F	
63°F	1920	69.7	4.27	0.74	0.89	1	64.1	4.8	0.75	0.92	1	58.7	5.43	0.77	0.95	1	53	6.14	0.79	0.99	1
	2400	73.5	4.32	0.8	0.98	1	67.7	4.84	0.82	1	1	62.6	5.47	0.85	1	1	57.5	6.2	0.88	1	1
	2880	77.2	4.37	0.86	1	1	71.8	4.9	0.89	1	1	66.4	5.52	0.92	1	1	60.8	6.24	0.97	1	1
67°F	1920	74.6	4.33	0.56	0.71	0.86	68.8	4.85	0.57	0.73	0.88	63.1	5.48	0.58	0.75	0.92	57.3	6.2	0.58	0.77	0.95
	2400	78.3	4.39	0.61	0.78	0.95	72.2	4.9	0.62	0.8	0.98	66	5.51	0.62	0.82	1	60	6.23	0.64	0.86	1
	2880	80.9	4.42	0.64	0.84	1	74.6	4.93	0.66	0.87	1	68	5.54	0.67	0.9	1	62	6.26	0.69	0.95	1
71°F	1920	79.5	4.4	0.42	0.55	0.69	73.6	4.91	0.42	0.56	0.71	67.5	5.53	0.4	0.57	0.73	61.4	6.25	0.4	0.57	0.75
	2400	83.3	4.45	0.45	0.6	0.76	76.9	4.96	0.44	0.61	0.78	70.5	5.57	0.43	0.62	0.8	64.3	6.29	0.41	0.63	0.84
	2880	85.8	4.5	0.46	0.64	0.82	79.4	5.01	0.45	0.66	0.86	72.5	5.6	0.45	0.67	0.88	66.1	6.32	0.45	0.68	0.93

## RATINGS - KCA

NOTE - For Temperatures and Capacities not shown in tables, see bulletin - Cooling Unit Rating Table Correction Factor Data in Miscellaneous Engineering Data section.

### 7.5 TON - KCA090S4

Entering Wet Bulb Temperature	Total Air Volume	Outdoor Air Temperature Entering Outdoor Coil																			
		85°F					95°F					105°F					115°F				
		Total Cool Cap.	Comp. Motor Input	Sensible To Total Ratio (S/T)			Total Cool Cap.	Comp. Motor Input	Sensible To Total Ratio (S/T)			Total Cool Cap.	Comp. Motor Input	Sensible To Total Ratio (S/T)			Total Cool Cap.	Comp. Motor Input	Sensible To Total Ratio (S/T)		
				Dry Bulb					Dry Bulb					Dry Bulb					Dry Bulb		
cfm	kBtuh	kW	75°F	80°F	85°F	kBtuh	kW	75°F	80°F	85°F	kBtuh	kW	75°F	80°F	85°F	kBtuh	kW	75°F	80°F	85°F	
63°F	2400	92.4	5.97	0.69	0.84	0.98	85.3	6.6	0.7	0.86	1	77.8	7.32	0.7	0.88	1	69.9	8.15	0.71	0.91	1
	3000	97.7	6.04	0.75	0.92	1	90.2	6.68	0.76	0.95	1	82.5	7.4	0.78	0.98	1	74.5	8.23	0.81	1	1
	3600	101.9	6.11	0.81	1	1	94.6	6.75	0.83	1	1	87.2	7.48	0.85	1	1	79.5	8.33	0.89	1	1
67°F	2400	99.4	6.07	0.54	0.67	0.81	91.8	6.7	0.53	0.68	0.83	84.2	7.43	0.53	0.68	0.85	75.9	8.26	0.52	0.7	0.88
	3000	104.5	6.15	0.57	0.73	0.89	96.8	6.78	0.58	0.74	0.91	88.7	7.51	0.57	0.76	0.95	79.9	8.34	0.58	0.79	0.99
	3600	108.5	6.21	0.61	0.79	0.97	100.2	6.84	0.62	0.81	0.99	92	7.57	0.62	0.84	1	82.7	8.39	0.62	0.87	1
71°F	2400	106.2	6.17	0.4	0.53	0.65	98.5	6.81	0.38	0.52	0.66	90.6	7.54	0.37	0.52	0.67	82.2	8.38	0.36	0.52	0.68
	3000	111.7	6.26	0.41	0.57	0.71	103.8	6.9	0.4	0.57	0.72	95.1	7.63	0.4	0.57	0.74	86.3	8.46	0.38	0.58	0.77
	3600	115.6	6.33	0.44	0.6	0.77	107.2	6.96	0.43	0.61	0.79	98.6	7.69	0.42	0.62	0.82	89	8.51	0.41	0.63	0.85

## RATINGS - KCB

NOTE - For Temperatures and Capacities not shown in tables, see bulletin - Cooling Unit Rating Table Correction Factor Data in Miscellaneous Engineering Data section.

### 2 TON - KCB024S4

Entering Wet Bulb Temperature	Total Air Volume	Outdoor Air Temperature Entering Outdoor Coil																			
		85°F					95°F					105°F					115°F				
		Total Cool Cap.	Comp. Motor Input	Sensible To Total Ratio (S/T)			Total Cool Cap.	Comp. Motor Input	Sensible To Total Ratio (S/T)			Total Cool Cap.	Comp. Motor Input	Sensible To Total Ratio (S/T)			Total Cool Cap.	Comp. Motor Input	Sensible To Total Ratio (S/T)		
				Dry Bulb					Dry Bulb					Dry Bulb					Dry Bulb		
cfm	kBtuh	kW	75°F	80°F	85°F	kBtuh	kW	75°F	80°F	85°F	kBtuh	kW	75°F	80°F	85°F	kBtuh	kW	75°F	80°F	85°F	
63°F	640	23.2	1.31	0.69	0.84	0.99	21.7	1.49	0.7	0.86	1	20.1	1.72	0.71	0.89	1	18.4	1.97	0.73	0.92	1
	800	24.6	1.3	0.75	0.93	1	23.1	1.48	0.76	0.95	1	21.4	1.7	0.78	0.98	1	19.7	1.95	0.8	1	1
	960	25.8	1.29	0.8	1	1	24.3	1.47	0.82	1	1	22.7	1.69	0.85	1	1	21	1.94	0.88	1	1
67°F	640	24.5	1.3	0.54	0.67	0.81	23	1.48	0.54	0.68	0.82	21.4	1.71	0.54	0.69	0.85	19.7	1.96	0.54	0.71	0.88
	800	26.1	1.28	0.58	0.72	0.89	24.5	1.47	0.58	0.74	0.91	22.7	1.69	0.58	0.75	0.94	20.8	1.94	0.59	0.78	0.98
	960	27.2	1.27	0.61	0.78	0.96	25.5	1.45	0.61	0.8	0.99	23.7	1.68	0.62	0.82	1	21.6	1.93	0.63	0.86	1
71°F	640	25.7	1.29	0.41	0.53	0.65	24.2	1.47	0.4	0.53	0.66	22.6	1.7	0.39	0.53	0.67	20.8	1.95	0.38	0.54	0.68
	800	27.4	1.27	0.42	0.57	0.7	25.8	1.45	0.42	0.57	0.72	24	1.68	0.41	0.58	0.73	22.1	1.93	0.39	0.58	0.76
	960	28.6	1.25	0.44	0.6	0.76	26.9	1.44	0.43	0.61	0.77	25	1.66	0.43	0.61	0.8	22.9	1.91	0.43	0.63	0.83

### 2.5 TON - KCB030S4

Entering Wet Bulb Temperature	Total Air Volume	Outdoor Air Temperature Entering Outdoor Coil																			
		85°F					95°F					105°F					115°F				
		Total Cool Cap.	Comp. Motor Input	Sensible To Total Ratio (S/T)			Total Cool Cap.	Comp. Motor Input	Sensible To Total Ratio (S/T)			Total Cool Cap.	Comp. Motor Input	Sensible To Total Ratio (S/T)			Total Cool Cap.	Comp. Motor Input	Sensible To Total Ratio (S/T)		
				Dry Bulb					Dry Bulb					Dry Bulb					Dry Bulb		
cfm	kBtuh	kW	75°F	80°F	85°F	kBtuh	kW	75°F	80°F	85°F	kBtuh	kW	75°F	80°F	85°F	kBtuh	kW	75°F	80°F	85°F	
63°F	800	29.2	1.66	0.7	0.85	1	28.1	1.9	0.71	0.87	1	26.3	2.21	0.73	0.9	1	24.6	2.69	0.74	0.93	1
	1000	30.7	1.66	0.76	0.95	1	29.5	1.9	0.77	0.97	1	27.7	2.21	0.79	1	1	26.1	2.69	0.81	1	1
	1200	32	1.66	0.82	1	1	30.9	1.91	0.83	1	1	29.2	2.22	0.86	1	1	27.5	2.69	0.9	1	1
67°F	800	30.9	1.66	0.55	0.68	0.82	29.7	1.91	0.55	0.69	0.83	27.9	2.22	0.56	0.7	0.86	26.2	2.69	0.56	0.72	0.89
	1000	32.3	1.67	0.59	0.74	0.92	31.1	1.91	0.59	0.75	0.93	29.2	2.22	0.6	0.77	0.96	27.3	2.68	0.61	0.79	0.99
	1200	33.3	1.67	0.6	0.8	1	32	1.92	0.62	0.81	1	30.1	2.22	0.63	0.84	1	28.2	2.7	0.65	0.87	1
71°F	800	32.5	1.67	0.41	0.54	0.66	31.3	1.91	0.41	0.54	0.67	29.5	2.22	0.41	0.55	0.68	27.7	2.69	0.41	0.56	0.7
	1000	33.9	1.67	0.44	0.58	0.73	32.6	1.92	0.43	0.58	0.73	30.7	2.23	0.43	0.59	0.75	28.8	2.69	0.43	0.59	0.77
	1200	34.8	1.68	0.44	0.61	0.78	33.5	1.92	0.44	0.6	0.8	31.5	2.23	0.44	0.63	0.83	29.7	2.69	0.44	0.64	0.85

### 3 TON - KCB036S4

Entering Wet Bulb Temperature	Total Air Volume	Outdoor Air Temperature Entering Outdoor Coil																			
		85°F					95°F					105°F					115°F				
		Total Cool Cap.	Comp. Motor Input	Sensible To Total Ratio (S/T)			Total Cool Cap.	Comp. Motor Input	Sensible To Total Ratio (S/T)			Total Cool Cap.	Comp. Motor Input	Sensible To Total Ratio (S/T)			Total Cool Cap.	Comp. Motor Input	Sensible To Total Ratio (S/T)		
				Dry Bulb					Dry Bulb					Dry Bulb					Dry Bulb		
cfm	kBtuh	kW	75°F	80°F	85°F	kBtuh	kW	75°F	80°F	85°F	kBtuh	kW	75°F	80°F	85°F	kBtuh	kW	75°F	80°F	85°F	
63°F	960	36.5	2.01	0.69	0.85	1	34.3	2.29	0.7	0.87	1	32	2.63	0.71	0.89	1	29.5	3.05	0.72	0.92	1
	1200	38.6	2.02	0.75	0.94	1	36.3	2.3	0.77	0.97	1	33.9	2.63	0.78	1	1	31.5	3.05	0.8	1	1
	1440	40.4	2.03	0.82	1	1	38.2	2.3	0.83	1	1	36	2.63	0.86	1	1	33.6	3.04	0.89	1	1
67°F	960	39	2.02	0.54	0.67	0.81	36.8	2.3	0.54	0.68	0.83	34.4	2.63	0.54	0.69	0.85	31.8	3.04	0.54	0.7	0.88
	1200	41.1	2.03	0.57	0.73	0.9	38.8	2.31	0.58	0.74	0.93	36.3	2.63	0.58	0.76	0.96	33.6	3.04	0.59	0.78	0.99
	1440	42.7	2.04	0.61	0.79	0.99	40.2	2.31	0.62	0.81	1	37.5	2.64	0.62	0.83	1	34.9	3.05	0.63	0.86	1
71°F	960	41.4	2.03	0.4	0.53	0.65	39.1	2.31	0.4	0.53	0.65	36.7	2.63	0.38	0.53	0.67	34.1	3.04	0.38	0.53	0.68
	1200	43.7	2.05	0.42	0.56	0.71	41.3	2.32	0.41	0.57	0.72	38.7	2.64	0.41	0.57	0.74	36.1	3.04	0.4	0.58	0.75
	1440	45.3	2.06	0.43	0.6	0.77	42.8	2.33	0.43	0.61	0.79	40.1	2.65	0.43	0.61	0.81	37.3	3.04	0.42	0.63	0.83

## RATINGS - KCB

NOTE - For Temperatures and Capacities not shown in tables, see bulletin - Cooling Unit Rating Table Correction Factor Data in Miscellaneous Engineering Data section.

### 4 TON - KCB048S4

Entering Wet Bulb Temperature	Total Air Volume	Outdoor Air Temperature Entering Outdoor Coil																			
		85°F					95°F					105°F					115°F				
		Total Cool Cap.	Comp. Motor Input	Sensible To Total Ratio (S/T)			Total Cool Cap.	Comp. Motor Input	Sensible To Total Ratio (S/T)			Total Cool Cap.	Comp. Motor Input	Sensible To Total Ratio (S/T)			Total Cool Cap.	Comp. Motor Input	Sensible To Total Ratio (S/T)		
				Dry Bulb					Dry Bulb					Dry Bulb					Dry Bulb		
cfm	kBtuh	kW	75°F	80°F	85°F	kBtuh	kW	75°F	80°F	85°F	kBtuh	kW	75°F	80°F	85°F	kBtuh	kW	75°F	80°F	85°F	
63°F	1280	47.6	2.86	0.68	0.84	1	44.1	3.23	0.69	0.87	1	40.7	3.66	0.7	0.9	1	37.1	4.16	0.72	0.95	1
	1600	50.1	2.88	0.74	0.95	1	46.6	3.25	0.76	0.98	1	43.1	3.68	0.78	1	1	39.7	4.19	0.81	1	1
	1920	52.5	2.89	0.81	1	1	49.1	3.27	0.83	1	1	45.7	3.7	0.87	1	1	42.2	4.21	0.91	1	1
67°F	1280	50.9	2.88	0.53	0.66	0.8	47.3	3.26	0.53	0.67	0.83	43.8	3.69	0.53	0.68	0.86	40.1	4.19	0.53	0.7	0.9
	1600	53.6	2.89	0.56	0.72	0.91	49.7	3.27	0.57	0.73	0.94	46	3.71	0.57	0.76	0.98	42	4.21	0.58	0.79	1
	1920	55.4	2.9	0.6	0.78	1	51.4	3.29	0.6	0.81	1	47.5	3.72	0.61	0.84	1	43.3	4.22	0.63	0.88	1
71°F	1280	54.1	2.9	0.39	0.52	0.64	50.4	3.28	0.38	0.52	0.65	46.8	3.71	0.37	0.52	0.66	42.8	4.21	0.37	0.52	0.68
	1600	56.8	2.91	0.41	0.55	0.7	52.9	3.3	0.4	0.56	0.71	49.1	3.73	0.4	0.57	0.73	45	4.23	0.39	0.58	0.76
	1920	58.9	2.92	0.42	0.59	0.76	54.8	3.31	0.42	0.6	0.79	50.8	3.74	0.42	0.61	0.82	46.5	4.25	0.41	0.62	0.86

### 5 TON - KCB060S4

Entering Wet Bulb Temperature	Total Air Volume	Outdoor Air Temperature Entering Outdoor Coil																			
		85°F					95°F					105°F					115°F				
		Total Cool Cap.	Comp. Motor Input	Sensible To Total Ratio (S/T)			Total Cool Cap.	Comp. Motor Input	Sensible To Total Ratio (S/T)			Total Cool Cap.	Comp. Motor Input	Sensible To Total Ratio (S/T)			Total Cool Cap.	Comp. Motor Input	Sensible To Total Ratio (S/T)		
				Dry Bulb					Dry Bulb					Dry Bulb					Dry Bulb		
cfm	kBtuh	kW	75°F	80°F	85°F	kBtuh	kW	75°F	80°F	85°F	kBtuh	kW	75°F	80°F	85°F	kBtuh	kW	75°F	80°F	85°F	
63°F	1600	60.1	3.41	0.68	0.84	1	56.8	3.86	0.7	0.86	1	53.1	4.39	0.71	0.89	1	48.9	5	0.73	0.93	1
	2000	63.5	3.44	0.75	0.95	1	59.9	3.88	0.76	0.97	1	55.9	4.41	0.78	1	1	51.9	5.02	0.81	1	1
	2400	66.4	3.45	0.8	1	1	63.1	3.91	0.83	1	1	59.5	4.44	0.86	1	1	55.3	5.07	0.9	1	1
67°F	1600	64.3	3.44	0.53	0.66	0.81	60.8	3.89	0.54	0.67	0.82	56.9	4.42	0.54	0.69	0.85	52.5	5.04	0.55	0.7	0.89
	2000	67.8	3.46	0.58	0.72	0.9	64	3.91	0.57	0.74	0.93	59.7	4.44	0.58	0.75	0.96	55.1	5.07	0.59	0.78	1
	2400	70.3	3.47	0.6	0.78	0.99	66.3	3.92	0.61	0.81	1	61.7	4.46	0.62	0.83	1	56.8	5.08	0.63	0.88	1
71°F	1600	68.8	3.46	0.4	0.52	0.64	65.2	3.92	0.4	0.53	0.65	61.1	4.45	0.39	0.53	0.66	56.3	5.08	0.38	0.54	0.68
	2000	72.5	3.48	0.41	0.57	0.7	68.4	3.94	0.41	0.56	0.72	63.8	4.47	0.41	0.57	0.73	58.7	5.1	0.41	0.58	0.75
	2400	74.7	3.49	0.42	0.59	0.76	70.5	3.95	0.43	0.6	0.78	66	4.49	0.43	0.61	0.81	60.7	5.12	0.42	0.63	0.85

### 6 TON - KCB072H4

Entering Wet Bulb Temperature	Total Air Volume	Outdoor Air Temperature Entering Outdoor Coil																			
		85°F					95°F					105°F					115°F				
		Total Cool Cap.	Comp. Motor Input	Sensible To Total Ratio (S/T)			Total Cool Cap.	Comp. Motor Input	Sensible To Total Ratio (S/T)			Total Cool Cap.	Comp. Motor Input	Sensible To Total Ratio (S/T)			Total Cool Cap.	Comp. Motor Input	Sensible To Total Ratio (S/T)		
				Dry Bulb					Dry Bulb					Dry Bulb					Dry Bulb		
cfm	kBtuh	kW	75°F	80°F	85°F	kBtuh	kW	75°F	80°F	85°F	kBtuh	kW	75°F	80°F	85°F	kBtuh	kW	75°F	80°F	85°F	
63°F	1920	68.1	4.47	0.67	0.83	1	64.4	4.95	0.68	0.86	1	60.3	5.5	0.7	0.9	1	55.9	6.12	0.71	0.94	1
	2400	71.8	4.48	0.72	0.94	1	67.8	4.97	0.74	0.97	1	63.4	5.51	0.77	1	1	59.4	6.14	0.81	1	1
	2880	74.6	4.49	0.79	1	1	71	4.98	0.82	1	1	67.1	5.53	0.85	1	1	62.8	6.16	0.9	1	1
67°F	1920	72.4	4.48	0.52	0.64	0.78	68.7	4.97	0.53	0.65	0.81	64.7	5.52	0.54	0.67	0.84	60	6.15	0.55	0.69	0.89
	2400	76.3	4.5	0.56	0.7	0.89	72.2	4.99	0.56	0.71	0.92	67.3	5.53	0.57	0.74	0.96	62.7	6.17	0.59	0.77	1
	2880	78.8	4.51	0.58	0.76	0.98	74.6	5	0.59	0.79	1	69.7	5.55	0.6	0.82	1	64.7	6.18	0.62	0.87	1
71°F	1920	77.2	4.5	0.39	0.51	0.62	73.1	4.99	0.39	0.51	0.63	68.7	5.54	0.4	0.52	0.65	63.9	6.17	0.4	0.54	0.67
	2400	81	4.52	0.41	0.55	0.68	76.7	5.01	0.41	0.55	0.69	71.9	5.56	0.41	0.56	0.71	66.6	6.19	0.41	0.57	0.74
	2880	83.4	4.53	0.42	0.58	0.73	79	5.02	0.42	0.58	0.75	74.1	5.57	0.43	0.6	0.79	68.7	6.2	0.43	0.61	0.83

## RATINGS - KCB

NOTE - For Temperatures and Capacities not shown in tables, see bulletin - Cooling Unit Rating Table Correction Factor Data in Miscellaneous Engineering Data section.

### 6 TON - STANDARD EFFICIENCY KCB074S4 (1ST STAGE)

Entering Wet Bulb Temperature	Total Air Volume	Outdoor Air Temperature Entering Outdoor Coil																			
		65°F					75°F					85°F					95°F				
		Total Cool Cap.	Comp. Motor Input	Sensible To Total Ratio (S/T)			Total Cool Cap.	Comp. Motor Input	Sensible To Total Ratio (S/T)			Total Cool Cap.	Comp. Motor Input	Sensible To Total Ratio (S/T)			Total Cool Cap.	Comp. Motor Input	Sensible To Total Ratio (S/T)		
				Dry Bulb					Dry Bulb					Dry Bulb					Dry Bulb		
cfm	kBtuh	kW	75°F	80°F	85°F	kBtuh	kW	75°F	80°F	85°F	kBtuh	kW	75°F	80°F	85°F	kBtuh	kW	75°F	80°F	85°F	
63°F	1200	53.3	2.3	0.68	0.81	0.92	51	2.62	0.69	0.82	0.94	48.3	2.99	0.7	0.83	0.96	45.6	3.41	0.71	0.85	0.98
	1600	57.8	2.29	0.74	0.88	1	55.2	2.61	0.75	0.9	1	52.5	2.98	0.77	0.92	1	49.3	3.4	0.78	0.95	1
	2000	61.2	2.28	0.8	0.96	1	58.2	2.6	0.81	0.98	1	55.3	2.98	0.83	1	1	52.5	3.4	0.84	1	1
67°F	1200	57.2	2.29	0.55	0.66	0.77	54.7	2.62	0.55	0.67	0.78	51.9	2.98	0.55	0.67	0.79	48.9	3.4	0.55	0.68	0.81
	1600	61.9	2.28	0.58	0.72	0.85	59.2	2.6	0.59	0.73	0.86	56.3	2.97	0.59	0.74	0.88	53	3.4	0.6	0.76	0.91
	2000	65.4	2.27	0.62	0.78	0.93	62.3	2.59	0.62	0.78	0.94	59.1	2.96	0.63	0.8	0.97	55.6	3.39	0.64	0.82	0.99
71°F	1200	61.2	2.28	0.42	0.53	0.63	58.6	2.61	0.42	0.53	0.64	55.8	2.97	0.42	0.53	0.64	52.6	3.4	0.41	0.53	0.65
	1600	66.3	2.26	0.44	0.57	0.69	63.3	2.59	0.44	0.57	0.7	60.2	2.96	0.44	0.58	0.71	56.7	3.39	0.44	0.59	0.73
	2000	69.6	2.25	0.46	0.61	0.75	66.5	2.58	0.46	0.61	0.76	63.1	2.95	0.45	0.61	0.77	59.6	3.38	0.46	0.63	0.8

### 6 TON - STANDARD EFFICIENCY KCB074S4 (2ND STAGE)

Entering Wet Bulb Temperature	Total Air Volume	Outdoor Air Temperature Entering Outdoor Coil																			
		85°F					95°F					105°F					115°F				
		Total Cool Cap.	Comp. Motor Input	Sensible To Total Ratio (S/T)			Total Cool Cap.	Comp. Motor Input	Sensible To Total Ratio (S/T)			Total Cool Cap.	Comp. Motor Input	Sensible To Total Ratio (S/T)			Total Cool Cap.	Comp. Motor Input	Sensible To Total Ratio (S/T)		
				Dry Bulb					Dry Bulb					Dry Bulb					Dry Bulb		
cfm	kBtuh	kW	75°F	80°F	85°F	kBtuh	kW	75°F	80°F	85°F	kBtuh	kW	75°F	80°F	85°F	kBtuh	kW	75°F	80°F	85°F	
63°F	1920	68.6	4.18	0.73	0.88	1	64.9	4.71	0.75	0.9	1	60.9	5.32	0.77	0.93	1	56.8	6.02	0.79	0.96	1
	2400	72.2	4.21	0.79	0.96	1	68.1	4.74	0.81	0.99	1	63.8	5.35	0.83	1	1	60	6.05	0.86	1	1
	2880	75.2	4.24	0.85	1	1	71.6	4.78	0.87	1	1	67.6	5.39	0.9	1	1	63.4	6.09	0.94	1	1
67°F	1920	73	4.22	0.58	0.71	0.85	69	4.75	0.58	0.73	0.87	64.8	5.36	0.59	0.74	0.89	60.4	6.05	0.6	0.77	0.93
	2400	76.7	4.25	0.62	0.77	0.93	72.4	4.79	0.62	0.79	0.95	67.9	5.4	0.63	0.81	0.98	63	6.08	0.65	0.84	1
	2880	79.1	4.28	0.64	0.83	0.99	74.8	4.82	0.66	0.85	1	69.9	5.42	0.67	0.88	1	65	6.1	0.69	0.91	1
71°F	1920	77.6	4.26	0.44	0.56	0.69	73.5	4.8	0.43	0.57	0.7	69.1	5.41	0.43	0.58	0.72	64.2	6.1	0.43	0.59	0.74
	2400	81.1	4.3	0.45	0.6	0.75	76.8	4.84	0.45	0.61	0.77	72	5.45	0.45	0.62	0.79	67.1	6.13	0.45	0.64	0.81
	2880	83.7	4.33	0.47	0.64	0.8	79.2	4.87	0.46	0.65	0.83	74.2	5.47	0.48	0.66	0.85	69.2	6.15	0.48	0.68	0.89

### 6 TON - HIGH EFFICIENCY KCB074H4 (1ST STAGE)

Entering Wet Bulb Temperature	Total Air Volume	Outdoor Air Temperature Entering Outdoor Coil																			
		65°F					75°F					85°F					95°F				
		Total Cool Cap.	Comp. Motor Input	Sensible To Total Ratio (S/T)			Total Cool Cap.	Comp. Motor Input	Sensible To Total Ratio (S/T)			Total Cool Cap.	Comp. Motor Input	Sensible To Total Ratio (S/T)			Total Cool Cap.	Comp. Motor Input	Sensible To Total Ratio (S/T)		
				Dry Bulb					Dry Bulb					Dry Bulb					Dry Bulb		
cfm	kBtuh	kW	75°F	80°F	85°F	kBtuh	kW	75°F	80°F	85°F	kBtuh	kW	75°F	80°F	85°F	kBtuh	kW	75°F	80°F	85°F	
63°F	1200	53.3	2.27	0.68	0.81	0.92	51	2.59	0.69	0.82	0.94	48.3	2.95	0.7	0.83	0.96	45.6	3.36	0.71	0.85	0.98
	1600	57.8	2.26	0.74	0.88	1	55.2	2.58	0.75	0.9	1	52.5	2.94	0.77	0.92	1	49.3	3.36	0.78	0.95	1
	2000	61.2	2.25	0.8	0.96	1	58.2	2.57	0.81	0.98	1	55.3	2.94	0.83	1	1	52.5	3.35	0.84	1	1
67°F	1200	57.2	2.26	0.55	0.66	0.77	54.7	2.58	0.55	0.67	0.78	51.9	2.94	0.55	0.67	0.79	48.9	3.36	0.55	0.68	0.81
	1600	61.9	2.25	0.58	0.72	0.85	59.2	2.57	0.59	0.73	0.86	56.3	2.93	0.59	0.74	0.88	53	3.35	0.6	0.76	0.91
	2000	65.4	2.24	0.62	0.78	0.93	62.3	2.56	0.62	0.78	0.94	59.2	2.93	0.63	0.8	0.97	55.6	3.34	0.64	0.82	0.99
71°F	1200	61.2	2.25	0.43	0.53	0.63	58.6	2.57	0.42	0.53	0.64	55.8	2.93	0.42	0.53	0.64	52.6	3.35	0.41	0.53	0.65
	1600	66.3	2.23	0.44	0.57	0.69	63.3	2.56	0.44	0.57	0.7	60.2	2.92	0.44	0.58	0.71	56.7	3.34	0.44	0.59	0.73
	2000	69.6	2.22	0.45	0.61	0.75	66.5	2.54	0.46	0.61	0.76	63.1	2.91	0.45	0.62	0.77	59.6	3.33	0.46	0.63	0.8

### 6 TON - HIGH EFFICIENCY KCB074H4 (2ND STAGE)

Entering Wet Bulb Temperature	Total Air Volume	Outdoor Air Temperature Entering Outdoor Coil																			
		85°F					95°F					105°F					115°F				
		Total Cool Cap.	Comp. Motor Input	Sensible To Total Ratio (S/T)			Total Cool Cap.	Comp. Motor Input	Sensible To Total Ratio (S/T)			Total Cool Cap.	Comp. Motor Input	Sensible To Total Ratio (S/T)			Total Cool Cap.	Comp. Motor Input	Sensible To Total Ratio (S/T)		
				Dry Bulb					Dry Bulb					Dry Bulb					Dry Bulb		
cfm	kBtuh	kW	75°F	80°F	85°F	kBtuh	kW	75°F	80°F	85°F	kBtuh	kW	75°F	80°F	85°F	kBtuh	kW	75°F	80°F	85°F	
63°F	1920	68.6	4.12	0.73	0.88	1	64.9	4.65	0.75	0.9	1	60.9	5.25	0.77	0.93	1	56.6	5.94	0.79	0.96	1
	2400	72.2	4.16	0.79	0.96	1	68.1	4.68	0.81	0.99	1	63.9	5.28	0.83	1	1	60	5.97	0.86	1	1
	2880	75.2	4.18	0.85	1	1	71.6	4.72	0.87	1	1	67.6	5.32	0.9	1	1	63.4	6.01	0.94	1	1
67°F	1920	73	4.16	0.57	0.71	0.85	69	4.69	0.59	0.73	0.87	64.8	5.29	0.59	0.74	0.89	60.4	5.97	0.6	0.77	0.93
	2400	76.7	4.2	0.62	0.77	0.93	72.4	4.73	0.62	0.79	0.95	67.9	5.32	0.63	0.81	0.98	63	6	0.64	0.84	1
	2880	79.1	4.22	0.64	0.83	0.99	74.8	4.75	0.66	0.85	1	69.9	5.34	0.67	0.88	1	65	6.02	0.69	0.91	1
71°F	1920	77.6	4.21	0.44	0.56	0.69	73.5	4.74	0.43	0.57	0.7	69.1	5.34	0.43	0.58	0.72	64.2	6.02	0.43	0.59	0.74
	2400	81.1	4.24	0.45	0.6	0.75	76.8	4.77	0.45	0.61	0.77	72	5.37	0.45	0.62	0.79	67.1	6.05	0.44	0.64	0.81
	2880	83.7	4.27	0.47	0.64	0.8	79.3	4.8	0.46	0.65	0.83	74.2	5.4	0.48	0.66	0.85	69.2	6.07	0.48	0.68	0.89

## BLOWER DATA - DIRECT DRIVE - KCB024

BLOWER TABLE INCLUDES RESISTANCE FOR BASE UNIT ONLY WITH DRY INDOOR COIL AND AIR FILTERS IN PLACE.

FOR ALL UNITS ADD:

1 - Any factory installed options air resistance (economizer, wet coil, etc.) See page 40.

2 - Any field installed accessories air resistance (electric heat, duct resistance, diffuser, etc.) See page 40.

External Static Pressure (in. w.g.)	Air Volume (cfm) at Various Blower Speeds					
	208 VOLTS			230 VOLTS		
	High	Medium	Low	High	Medium	Low
<b>2 Ton Standard Efficiency (Downflow)</b>						<b>KCB024S</b>
0.0	1244	956	859	1414	1098	876
0.1	1226	934	820	1401	1092	870
0.2	1201	906	782	1379	1070	848
0.3	1180	877	727	1348	1039	819
0.4	1152	841	690	1318	1008	775
0.5	1118	812	634	1288	968	746
0.6	1090	768	579	1243	937	702
0.7	1048	725	505	1197	890	659
0.8	1006	667	431	1152	827	600
0.9	950	609	357	1076	749	528
1.0	839	493	248	986	623	468
<b>2 Ton Standard Efficiency (Horizontal)</b>						<b>KCB024S</b>
0.0	1166	910	801	1376	1071	842
0.1	1156	893	770	1342	1054	826
0.2	1136	866	734	1307	1021	808
0.3	1115	826	697	1269	982	771
0.4	1083	800	643	1232	956	734
0.5	1051	747	589	1194	903	698
0.6	1009	707	534	1137	850	662
0.7	946	668	467	1100	797	588
0.8	861	588	396	1024	744	534
0.9	736	508	319	948	652	466
1.0	560	385	237	845	549	392



## BLOWER DATA - DIRECT DRIVE - KCB030

**BLOWER TABLE INCLUDES RESISTANCE FOR BASE UNIT ONLY WITH DRY INDOOR COIL AND AIR FILTERS IN PLACE.**

FOR ALL UNITS ADD:

1 - Any factory installed options air resistance (economizer, wet coil, etc.) See page 40.

2 - Any field installed accessories air resistance (electric heat, duct resistance, diffuser, etc.) See page 40.

External Static Pressure (in. w.g.)	Air Volume (cfm) at Various Blower Speeds					
	208 VOLTS			230 VOLTS		
	High	Medium	Low	High	Medium	Low
<b>2.5 Ton Standard Efficiency (Downflow)</b>						<b>KCB030S</b>
0.0	1199	928	838	1379	1085	877
0.1	1229	926	813	1409	1086	872
0.2	1206	928	782	1367	1094	850
0.3	1183	881	742	1350	1047	820
0.4	1159	843	686	1321	1009	783
0.5	1136	812	643	1282	981	762
0.6	1103	766	569	1242	921	705
0.7	1046	728	496	1195	888	625
0.8	953	648	432	1134	792	583
0.9	909	584	335	1037	738	492
1.0	783	465	247	926	592	411
<b>2.5 Ton Standard Efficiency (Horizontal)</b>						<b>KCB030S</b>
0.0	1152	909	801	1325	1063	838
0.1	1152	893	770	1321	1048	826
0.2	1136	866	734	1288	1021	798
0.3	1104	826	697	1260	982	771
0.4	1072	787	643	1222	942	734
0.5	1041	747	589	1175	903	698
0.6	1009	707	534	1137	850	662
0.7	946	654	467	1081	797	588
0.8	861	588	396	1024	718	535
0.9	798	508	319	911	642	468
1.0	715	443	237	846	564	394

## BLOWER DATA - DIRECT DRIVE - KCA/KCB036, KCA/KCB048

BLOWER TABLE INCLUDES RESISTANCE FOR BASE UNIT ONLY WITH DRY INDOOR COIL AND AIR FILTERS IN PLACE.

FOR ALL UNITS ADD:

1 - Any factory installed options air resistance (economizer, wet coil, etc.) See page 40.

2 - Any field installed accessories air resistance (electric heat, duct resistance, diffuser, etc.) See page 40.

External Static Pressure (in. w.g.)	Air Volume (cfm) at Various Blower Speeds								
	208 VOLTS			230 VOLTS			460/575 VOLTS		
	High	Medium	Low	High	Medium	Low	High	Medium	Low
<b>3 and 4 Ton Standard Efficiency (Downflow)</b>					<b>KCA/KCB036S and KCA/KCB048S</b>				
0.0	1938	1552	1119	2167	1772	1317	2136	1716	1212
0.1	1992	1586	1128	2167	1780	1315	2104	1728	1208
0.2	1915	1592	1137	2100	1792	1307	2052	1684	1197
0.3	1865	1536	1083	2043	1735	1266	1994	1647	1172
0.4	1813	1495	1033	1986	1678	1204	1918	1597	1134
0.5	1762	1444	976	1909	1621	1164	1861	1534	1096
0.6	1694	1391	899	1814	1535	1082	1765	1485	1059
0.7	1609	1331	817	1718	1478	1000	1689	1410	996
0.8	1471	1220	730	1603	1364	918	1613	1335	920
0.9	1368	1066	522	1488	1250	755	1498	1235	848
1.0	1108	869	402	1259	1021	640	1345	1036	763
<b>3 and 4 Ton Standard Efficiency (Horizontal)</b>					<b>KCA/KCB036S and KCA/KCB048S</b>				
0.0	1862	1520	1070	2082	1736	1259	2085	1745	1247
0.1	1867	1530	1069	2031	1717	1246	2070	1744	1257
0.2	1804	1485	1067	1978	1672	1227	2016	1690	1225
0.3	1741	1440	1018	1907	1627	1190	1944	1643	1192
0.4	1677	1396	968	1837	1567	1128	1890	1596	1160
0.5	1614	1329	894	1749	1492	1066	1800	1533	1111
0.6	1550	1284	844	1660	1417	1016	1727	1455	1062
0.7	1455	1195	769	1554	1327	941	1655	1377	996
0.8	1329	1106	670	1448	1237	842	1511	1283	865
0.9	1202	927	496	1307	1087	718	1403	1190	784
1.0	1012	828	385	1025	973	613	1222	1002	670

## BLOWER DATA - DIRECT DRIVE - KCA060

BLOWER TABLE INCLUDES RESISTANCE FOR BASE UNIT ONLY WITH DRY INDOOR COIL AND AIR FILTERS IN PLACE.

FOR ALL UNITS ADD:

1 - Any factory installed options air resistance (economizer, wet coil, etc.) See page 40.

2 - Any field installed accessories air resistance (electric heat, duct resistance, diffuser, etc.) See page 40.

External Static Pressure (in. w.g.)	Air Volume (cfm) at Various Blower Speeds					
	208 VOLTS		230 VOLTS		460/575 VOLTS	
	High	Low	High	Low	High	Low
<b>5 Ton Standard Efficiency (Downflow)</b>						<b>KCA060S</b>
0.0	2121	1644	2324	1952	2160	1750
0.1	2162	1660	2315	1991	2128	1733
0.2	2100	1704	2285	1946	2092	1712
0.3	2078	1667	2230	1928	2054	1687
0.4	2056	1646	2185	1909	2005	1652
0.5	2014	1626	2154	1873	1972	1629
0.6	1953	1592	2049	1821	1907	1583
0.7	1913	1594	1966	1787	1858	1549
0.8	1830	1519	1936	1715	1810	1515
0.9	1774	1509	1763	1650	1744	1469
1.0	1601	1319	1649	1508	1679	1400
<b>5 Ton Standard Efficiency (Horizontal)</b>						<b>KCA060S</b>
0.0	2038	1611	2222	1875	2225	1885
0.1	2026	1601	2194	1866	2236	1895
0.2	1978	1590	2145	1833	2186	1853
0.3	1940	1563	2096	1800	2137	1818
0.4	1902	1537	2047	1766	2106	1799
0.5	1845	1497	1973	1716	2031	1763
0.6	1787	1470	1924	1666	2002	1711
0.7	1730	1431	1850	1616	1970	1677
0.8	1653	1378	1776	1549	1853	1607
0.9	1558	1312	1677	1449	1800	1586
1.0	1462	1257	1579	1377	1750	1418

## BLOWER DATA - DIRECT DRIVE - KCB060

**BLOWER TABLE INCLUDES RESISTANCE FOR BASE UNIT ONLY WITH DRY INDOOR COIL AND AIR FILTERS IN PLACE.**

FOR ALL UNITS ADD:

1 - Any factory installed options air resistance (economizer, wet coil, etc.) See page 40.

2 - Any field installed accessories air resistance (electric heat, duct resistance, diffuser, etc.) See page 40.

External Static Pressure (in. w.g.)	Air Volume (cfm) at Various Blower Speeds					
	208 VOLTS		230 VOLTS		460/575 VOLTS	
	High	Low	High	Low	High	Low
<b>5 Ton Standard Efficiency (Downflow)</b>						<b>KCB060S</b>
0.0	1883	1570	2074	1785	2074	1785
0.1	1871	1550	2050	1760	2050	1760
0.2	1855	1538	2018	1735	2018	1735
0.3	1828	1523	1986	1704	1986	1704
0.4	1786	1499	1937	1679	1937	1679
0.5	1759	1476	1905	1642	1905	1642
0.6	1718	1452	1856	1605	1856	1605
0.7	1676	1421	1791	1567	1791	1567
0.8	1622	1358	1726	1505	1726	1505
0.9	1539	1277	1628	1406	1628	1406
1.0	1399	---	1502	1300	1502	1300
<b>5 Ton Standard Efficiency (Horizontal)</b>						<b>KCB060S</b>
0.0	1852	1534	2046	1713	2046	1713
0.1	1844	1532	2024	1711	2024	1711
0.2	1831	1526	1998	1706	1998	1706
0.3	1800	1504	1954	1681	1954	1681
0.4	1769	1477	1918	1654	1918	1654
0.5	1722	1450	1865	1612	1865	1612
0.6	1674	1423	1812	1570	1812	1570
0.7	1627	1369	1742	1515	1742	1515
0.8	1565	1315	1672	1459	1672	1459
0.9	1470	1241	1530	1376	1530	1376
1.0	1323	---	1426	1242	1426	1242

## BLOWER DATA - BELT DRIVE - KCA/KCB036

BLOWER TABLE INCLUDES RESISTANCE FOR BASE UNIT ONLY WITH DRY INDOOR COIL AND AIR FILTERS IN PLACE.

FOR ALL UNITS ADD:

1 - Any factory installed options air resistance (economizer, wet coil, etc.)

2 - Any field installed accessories air resistance (electric heat, duct resistance, diffuser, etc.)

See page 40 for blower motors and drives and wet coil and options/accessory air resistance data.

### DOWNFLOW

Air Volume cfm	External Static - in. w.g.															
	0.10		0.20		0.30		0.40		0.50		0.60		0.70		0.80	
	RPM	BHP	RPM	BHP	RPM	BHP	RPM	BHP	RPM	BHP	RPM	BHP	RPM	BHP	RPM	BHP
	Field Furnished						Drive Kit A01									
900	486	0.12	554	0.16	623	0.20	695	0.22	767	0.23	836	0.25	897	0.28	953	0.30
1000	508	0.15	576	0.19	643	0.22	713	0.24	783	0.26	848	0.28	907	0.30	961	0.33
1100	533	0.18	599	0.22	665	0.25	733	0.27	800	0.28	863	0.31	919	0.34	971	0.36
1200	560	0.21	625	0.25	689	0.28	755	0.30	820	0.32	879	0.34	932	0.37	983	0.40
1300	591	0.24	654	0.28	716	0.31	779	0.33	841	0.35	897	0.38	948	0.41	996	0.44
1400	631	0.26	690	0.30	748	0.34	807	0.36	864	0.39	916	0.42	964	0.46	1011	0.49
1500	676	0.28	729	0.33	782	0.36	835	0.40	887	0.43	935	0.47	981	0.50	1028	0.54

Air Volume cfm	External Static - in. w.g.															
	0.90		1.00		1.10		1.20		1.30		1.40		1.50		1.60	
	RPM	BHP	RPM	BHP	RPM	BHP	RPM	BHP	RPM	BHP	RPM	BHP	RPM	BHP	RPM	BHP
	Kit A01		Drive Kit A05													
900	1004	0.33	1055	0.35	1106	0.37	1152	0.40	1193	0.43	1232	0.46	1269	0.49	1305	0.52
1000	1011	0.36	1062	0.38	1111	0.41	1157	0.43	1199	0.47	1238	0.50	1276	0.53	1311	0.56
1100	1020	0.39	1070	0.41	1118	0.44	1163	0.47	1206	0.51	1245	0.54	1282	0.58	1318	0.61
1200	1031	0.43	1079	0.45	1127	0.48	1171	0.52	1213	0.55	1252	0.59	1289	0.62	1324	0.66
1300	1044	0.47	1091	0.49	1137	0.53	1181	0.56	1221	0.60	1259	0.64	1296	0.68	1330	0.71
1400	1058	0.51	1105	0.54	1150	0.57	1191	0.61	1231	0.65	1268	0.69	1303	0.73	1337	0.77
1500	1074	0.56	1120	0.59	1163	0.63	1203	0.67	1241	0.71	1277	0.75	1312	0.79	1345	0.82

### HORIZONTAL

Air Volume cfm	External Static - in. w.g.															
	0.10		0.20		0.30		0.40		0.50		0.60		0.70		0.80	
	RPM	BHP	RPM	BHP	RPM	BHP	RPM	BHP	RPM	BHP	RPM	BHP	RPM	BHP	RPM	BHP
	Field Furnished						Drive Kit A01									
900	485	0.11	554	0.14	627	0.16	703	0.18	780	0.21	841	0.23	888	0.27	935	0.30
1000	509	0.13	578	0.16	649	0.19	722	0.21	796	0.23	854	0.26	900	0.29	947	0.33
1100	537	0.16	605	0.19	674	0.21	744	0.24	813	0.26	868	0.29	913	0.33	959	0.36
1200	567	0.19	633	0.22	700	0.24	768	0.27	833	0.30	884	0.33	928	0.37	974	0.40
1300	599	0.22	664	0.25	729	0.28	793	0.30	853	0.33	902	0.37	945	0.41	990	0.44
1400	634	0.26	697	0.29	758	0.31	819	0.34	875	0.38	921	0.42	964	0.46	1008	0.49
1500	669	0.30	730	0.33	789	0.36	846	0.39	897	0.42	941	0.47	983	0.51	1028	0.54

Air Volume cfm	External Static - in. w.g.															
	0.90		1.00		1.10		1.20		1.30		1.40		1.50		1.60	
	RPM	BHP	RPM	BHP	RPM	BHP	RPM	BHP	RPM	BHP	RPM	BHP	RPM	BHP	RPM	BHP
	Kit A01		Kit A05													
900	986	0.32	1039	0.35	1090	0.37	1137	0.40	1177	0.43	1214	0.46	1248	0.49	1280	0.51
1000	997	0.35	1048	0.38	1098	0.41	1143	0.44	1184	0.47	1221	0.50	1255	0.53	1287	0.56
1100	1008	0.39	1059	0.41	1107	0.44	1150	0.47	1191	0.51	1228	0.54	1263	0.57	1295	0.60
1200	1022	0.43	1071	0.45	1117	0.48	1160	0.52	1200	0.55	1237	0.59	1271	0.62	1303	0.66
1300	1037	0.47	1085	0.50	1130	0.53	1171	0.57	1210	0.60	1246	0.64	1280	0.68	1312	0.71
1400	1054	0.52	1100	0.54	1144	0.58	1183	0.62	1221	0.66	1256	0.70	1290	0.73	1321	0.77
1500	1073	0.57	1117	0.60	1159	0.64	1197	0.67	1234	0.71	1268	0.75	1301	0.79	1332	0.83

## BLOWER DATA - BELT DRIVE - KCA/KCBO48

BLOWER TABLE INCLUDES RESISTANCE FOR BASE UNIT ONLY WITH DRY INDOOR COIL AND AIR FILTERS IN PLACE.

FOR ALL UNITS ADD:

1 - Any factory installed options air resistance (economizer, wet coil, etc.) See page 40.

2 - Any field installed accessories air resistance (electric heat, duct resistance, diffuser, etc.) See page 40.

See page 40 for blower motors and drives and wet coil and options/accessory air resistance data.

### DOWNFLOW

Air Volume cfm	External Static - in. w.g.															
	0.10		0.20		0.30		0.40		0.50		0.60		0.70		0.80	
	RPM	BHP	RPM	BHP	RPM	BHP	RPM	BHP	RPM	BHP	RPM	BHP	RPM	BHP	RPM	BHP
	Field Furnished						Drive Kit A02									
1200	560	0.21	625	0.25	689	0.28	755	0.30	820	0.32	879	0.34	932	0.37	983	0.40
1300	591	0.24	654	0.28	716	0.31	779	0.33	841	0.35	897	0.38	948	0.41	996	0.44
1400	631	0.26	690	0.30	748	0.34	807	0.36	864	0.39	916	0.42	964	0.46	1011	0.49
1500	675	0.28	729	0.33	782	0.36	835	0.40	887	0.43	935	0.47	981	0.50	1028	0.54
1600	718	0.31	766	0.35	814	0.40	862	0.44	910	0.48	955	0.52	1000	0.55	1046	0.59
1700	756	0.34	799	0.39	843	0.44	887	0.49	932	0.53	976	0.57	1020	0.61	1066	0.64
1800	787	0.40	828	0.45	870	0.50	912	0.55	955	0.59	999	0.63	1043	0.67	1089	0.70
1900	815	0.46	855	0.51	897	0.57	939	0.62	981	0.66	1024	0.69	1068	0.73	1113	0.76
2000	843	0.53	884	0.59	925	0.64	968	0.68	1009	0.72	1052	0.76	1095	0.79	1138	0.83

Air Volume cfm	External Static - in. w.g.															
	0.90		1.00		1.10		1.20		1.30		1.40		1.50		1.60	
	RPM	BHP	RPM	BHP	RPM	BHP	RPM	BHP	RPM	BHP	RPM	BHP	RPM	BHP	RPM	BHP
	Drive Kit A02				Drive Kit A06											
1200	1031	0.43	1079	0.45	1127	0.48	1171	0.52	1213	0.55	1252	0.59	1289	0.62	1324	0.66
1300	1044	0.47	1091	0.49	1137	0.53	1181	0.56	1221	0.60	1259	0.64	1296	0.68	1330	0.71
1400	1058	0.51	1105	0.54	1150	0.57	1191	0.61	1231	0.65	1268	0.69	1303	0.73	1337	0.77
1500	1074	0.56	1120	0.59	1163	0.63	1203	0.67	1241	0.71	1277	0.75	1312	0.79	1345	0.82
1600	1092	0.61	1137	0.65	1178	0.68	1216	0.72	1253	0.76	1288	0.80	1321	0.84	1354	0.88
1700	1112	0.67	1155	0.70	1193	0.75	1230	0.79	1265	0.83	1299	0.87	1332	0.91	1364	0.95
1800	1133	0.73	1174	0.77	1209	0.81	1244	0.85	1278	0.90	1311	0.94	1343	0.98	1375	1.02
1900	1156	0.80	1193	0.84	1226	0.89	1260	0.93	1293	0.97	1325	1.01	1356	1.06	1388	1.10
2000	1178	0.87	1213	0.92	1243	0.97	1275	1.02	1307	1.06	1339	1.10	1370	1.14	1402	1.18

### HORIZONTAL

Air Volume cfm	External Static - in. w.g.															
	0.10		0.20		0.30		0.40		0.50		0.60		0.70		0.80	
	RPM	BHP	RPM	BHP	RPM	BHP	RPM	BHP	RPM	BHP	RPM	BHP	RPM	BHP	RPM	BHP
	Field Furnished						Drive Kit A02									
1200	567	0.19	633	0.22	700	0.24	768	0.27	833	0.30	884	0.33	928	0.37	974	0.40
1300	599	0.22	664	0.25	729	0.28	793	0.30	853	0.33	902	0.37	945	0.41	990	0.44
1400	634	0.26	697	0.29	758	0.31	819	0.34	875	0.38	921	0.42	964	0.46	1008	0.49
1500	669	0.30	730	0.33	789	0.36	846	0.39	897	0.42	941	0.47	983	0.51	1028	0.54
1600	705	0.34	763	0.37	819	0.40	873	0.43	921	0.48	963	0.52	1004	0.56	1048	0.59
1700	741	0.38	796	0.41	850	0.45	900	0.49	945	0.53	985	0.58	1026	0.62	1070	0.65
1800	776	0.43	829	0.46	880	0.51	927	0.55	970	0.60	1009	0.64	1050	0.68	1093	0.71
1900	812	0.48	862	0.52	910	0.57	955	0.62	996	0.66	1035	0.71	1076	0.74	1118	0.78
2000	847	0.54	895	0.59	941	0.64	984	0.69	1023	0.74	1062	0.78	1103	0.81	1144	0.85

Air Volume cfm	External Static - in. w.g.															
	0.90		1.00		1.10		1.20		1.30		1.40		1.50		1.60	
	RPM	BHP	RPM	BHP	RPM	BHP	RPM	BHP	RPM	BHP	RPM	BHP	RPM	BHP	RPM	BHP
	Drive Kit A02				Drive Kit A06											
1200	1022	0.43	1071	0.45	1117	0.48	1160	0.52	1200	0.55	1237	0.59	1271	0.62	1303	0.66
1300	1037	0.47	1085	0.50	1130	0.53	1171	0.57	1210	0.60	1246	0.64	1280	0.68	1312	0.71
1400	1054	0.52	1100	0.54	1144	0.58	1183	0.62	1221	0.66	1256	0.70	1290	0.73	1321	0.77
1500	1073	0.57	1117	0.60	1159	0.64	1197	0.67	1234	0.71	1268	0.75	1301	0.79	1332	0.83
1600	1093	0.62	1136	0.66	1175	0.70	1212	0.74	1247	0.78	1281	0.82	1313	0.86	1344	0.90
1700	1114	0.68	1155	0.72	1192	0.76	1227	0.80	1262	0.85	1295	0.89	1327	0.93	1358	0.97
1800	1136	0.75	1175	0.79	1210	0.83	1245	0.88	1278	0.92	1311	0.97	1342	1.01	1373	1.05
1900	1159	0.82	1197	0.86	1229	0.92	1263	0.97	1296	1.01	1328	1.06	1359	1.10	1390	1.14
2000	1183	0.90	1218	0.95	1249	1.01	1282	1.06	1314	1.11	1346	1.15	1377	1.20	1408	1.24

## BLOWER DATA - BELT DRIVE - KCA060

BLOWER TABLE INCLUDES RESISTANCE FOR BASE UNIT ONLY WITH DRY INDOOR COIL AND AIR FILTERS IN PLACE.

FOR ALL UNITS ADD:

1 - Any factory installed options air resistance (economizer, wet coil, etc.) See page 40.

2 - Any field installed accessories air resistance (electric heat, duct resistance, diffuser, etc.) See page 40.

See page 40 for blower motors and drives and wet coil and options/accessory air resistance data.

### DOWNFLOW

Air Volume cfm	External Static - in. w.g.															
	0.10		0.20		0.30		0.40		0.50		0.60		0.70		0.80	
	RPM	BHP	RPM	BHP	RPM	BHP	RPM	BHP	RPM	BHP	RPM	BHP	RPM	BHP	RPM	BHP
	Field Furnished						Drive Kit A03									
1600	738	0.32	785	0.36	831	0.41	878	0.45	923	0.49	969	0.53	1014	0.57	1061	0.59
1700	773	0.36	816	0.41	859	0.46	903	0.51	947	0.55	991	0.58	1036	0.62	1082	0.65
1800	803	0.42	844	0.47	886	0.52	929	0.57	972	0.61	1016	0.64	1060	0.68	1106	0.71
1900	831	0.48	872	0.54	915	0.59	957	0.63	1000	0.67	1043	0.71	1087	0.74	1131	0.78
2000	861	0.56	903	0.61	945	0.66	988	0.70	1030	0.74	1072	0.77	1115	0.81	1157	0.85
2100	893	0.63	935	0.69	978	0.73	1019	0.78	1060	0.81	1101	0.85	1143	0.89	1182	0.93
2200	927	0.71	969	0.76	1011	0.81	1052	0.85	1091	0.89	1131	0.93	1170	0.97	1206	1.02
2300	963	0.79	1004	0.84	1045	0.89	1084	0.93	1122	0.97	1159	1.02	1195	1.07	1228	1.13
2400	999	0.88	1039	0.92	1078	0.97	1115	1.02	1151	1.06	1186	1.12	1219	1.18	1250	1.24

Air Volume cfm	External Static - in. w.g.															
	0.90		1.00		1.10		1.20		1.30		1.40		1.50		1.60	
	RPM	BHP	RPM	BHP	RPM	BHP	RPM	BHP	RPM	BHP	RPM	BHP	RPM	BHP	RPM	BHP
	Drive Kit A03								Drive Kit A07							
1600	1107	0.62	1151	0.66	1190	0.70	1228	0.74	1264	0.78	1298	0.82	1332	0.86	1364	0.90
1700	1128	0.68	1169	0.72	1206	0.76	1242	0.80	1277	0.84	1310	0.88	1343	0.92	1375	0.96
1800	1150	0.74	1189	0.79	1223	0.83	1257	0.87	1291	0.91	1324	0.95	1356	0.99	1388	1.03
1900	1173	0.81	1208	0.86	1240	0.91	1273	0.95	1306	0.99	1338	1.03	1369	1.07	1401	1.12
2000	1195	0.89	1228	0.94	1257	0.99	1290	1.04	1321	1.08	1353	1.12	1384	1.16	1416	1.20
2100	1217	0.98	1247	1.04	1275	1.09	1306	1.14	1338	1.18	1369	1.22	1400	1.25	1432	1.29
2200	1238	1.08	1265	1.14	1293	1.19	1324	1.24	1355	1.28	1387	1.31	1418	1.35	1450	1.39
2300	1257	1.19	1284	1.25	1313	1.30	1344	1.34	1375	1.38	1406	1.41	1437	1.45	1470	1.48
2400	1278	1.30	1305	1.36	1334	1.40	1364	1.44	1395	1.48	1427	1.51	1458	1.55	1492	1.58

### HORIZONTAL

Air Volume cfm	External Static - in. w.g.															
	0.10		0.20		0.30		0.40		0.50		0.60		0.70		0.80	
	RPM	BHP	RPM	BHP	RPM	BHP	RPM	BHP	RPM	BHP	RPM	BHP	RPM	BHP	RPM	BHP
	Field Furnished						Drive Kit A03									
1600	752	0.30	798	0.35	844	0.40	889	0.45	933	0.49	975	0.53	1018	0.57	1062	0.60
1700	785	0.35	827	0.40	871	0.46	914	0.51	957	0.55	999	0.59	1042	0.63	1085	0.66
1800	813	0.42	855	0.47	898	0.52	940	0.57	983	0.62	1025	0.66	1067	0.69	1110	0.72
1900	841	0.49	883	0.54	926	0.60	969	0.65	1011	0.69	1052	0.72	1094	0.76	1136	0.79
2000	871	0.56	914	0.62	957	0.67	1000	0.72	1040	0.76	1081	0.79	1122	0.83	1162	0.87
2100	903	0.64	946	0.70	990	0.75	1031	0.79	1071	0.83	1110	0.87	1150	0.91	1189	0.96
2200	937	0.73	981	0.78	1023	0.83	1063	0.87	1102	0.91	1140	0.96	1178	1.01	1215	1.07
2300	973	0.81	1015	0.86	1056	0.91	1095	0.96	1132	1.01	1170	1.06	1206	1.12	1242	1.19
2400	1010	0.91	1051	0.96	1090	1.01	1127	1.06	1164	1.11	1200	1.18	1235	1.24	1269	1.31

Air Volume cfm	External Static - in. w.g.															
	0.90		1.00		1.10		1.20		1.30		1.40		1.50		1.60	
	RPM	BHP	RPM	BHP	RPM	BHP	RPM	BHP	RPM	BHP	RPM	BHP	RPM	BHP	RPM	BHP
	Drive Kit A03								Drive Kit A07							
1600	1107	0.63	1149	0.67	1187	0.71	1223	0.75	1258	0.79	1291	0.83	1323	0.87	1354	0.91
1700	1129	0.69	1169	0.73	1204	0.78	1240	0.82	1274	0.86	1306	0.90	1338	0.95	1369	0.99
1800	1152	0.76	1190	0.80	1223	0.85	1258	0.90	1291	0.94	1323	0.99	1354	1.03	1385	1.07
1900	1176	0.83	1212	0.89	1243	0.94	1277	0.99	1309	1.03	1341	1.08	1372	1.12	1402	1.16
2000	1201	0.92	1234	0.98	1264	1.04	1296	1.09	1329	1.13	1360	1.18	1391	1.22	1422	1.26
2100	1225	1.02	1256	1.08	1285	1.14	1318	1.19	1349	1.24	1381	1.28	1412	1.32	1442	1.36
2200	1249	1.13	1279	1.19	1308	1.25	1340	1.30	1372	1.34	1403	1.38	1434	1.42	1465	1.46
2300	1273	1.25	1303	1.31	1332	1.36	1364	1.41	1396	1.45	1427	1.49	1458	1.53	1490	1.57
2400	1300	1.37	1329	1.43	1359	1.47	1390	1.52	1422	1.56	1453	1.60	1484	1.64	1516	1.67

## BLOWER DATA - BELT DRIVE - KCBO60

BLOWER TABLE INCLUDES RESISTANCE FOR BASE UNIT ONLY WITH DRY INDOOR COIL AND AIR FILTERS IN PLACE.

FOR ALL UNITS ADD:

1 - Any factory installed options air resistance (economizer, wet coil, etc.) See page 40.

2 - Any field installed accessories air resistance (electric heat, duct resistance, diffuser, etc.) See page 40.

See page 40 for blower motors and drives and wet coil and options/accessory air resistance data.

### DOWNFLOW

Air Volume cfm	External Static - in. w.g.															
	0.10		0.20		0.30		0.40		0.50		0.60		0.70		0.80	
	RPM	BHP	RPM	BHP	RPM	BHP	RPM	BHP	RPM	BHP	RPM	BHP	RPM	BHP	RPM	BHP
	Field Furnished								Drive Kit A03							
1600	665	0.30	716	0.34	768	0.38	819	0.41	879	0.44	937	0.46	985	0.49	1022	0.52
1700	723	0.31	768	0.35	814	0.39	860	0.43	910	0.47	959	0.50	1001	0.54	1037	0.58
1800	779	0.32	818	0.37	857	0.41	897	0.46	939	0.50	980	0.55	1018	0.59	1054	0.64
1900	826	0.36	859	0.41	894	0.45	928	0.50	964	0.56	1000	0.61	1036	0.66	1072	0.70
2000	857	0.42	889	0.47	920	0.52	952	0.57	986	0.62	1020	0.68	1055	0.73	1091	0.77
2100	878	0.49	909	0.54	940	0.59	973	0.64	1006	0.70	1041	0.75	1076	0.80	1112	0.85
2200	897	0.55	929	0.61	961	0.66	994	0.72	1028	0.78	1063	0.83	1099	0.89	1134	0.93
2300	918	0.62	950	0.68	983	0.74	1017	0.80	1052	0.86	1087	0.92	1122	0.97	1157	1.02
2400	941	0.70	974	0.77	1008	0.83	1042	0.90	1077	0.96	1111	1.01	1146	1.06	1181	1.11

Air Volume cfm	External Static - in. w.g.															
	0.90		1.00		1.10		1.20		1.30		1.40		1.50		1.60	
	RPM	BHP	RPM	BHP	RPM	BHP	RPM	BHP	RPM	BHP	RPM	BHP	RPM	BHP	RPM	BHP
	Drive Kit A03								Drive Kit A07							
1600	1059	0.57	1098	0.61	1138	0.65	1177	0.68	1218	0.71	1257	0.75	1290	0.79	1319	0.83
1700	1074	0.62	1113	0.66	1152	0.70	1190	0.74	1231	0.77	1268	0.80	1299	0.84	1328	0.89
1800	1091	0.68	1129	0.72	1167	0.76	1205	0.80	1244	0.83	1280	0.87	1310	0.91	1338	0.95
1900	1109	0.75	1146	0.79	1183	0.82	1221	0.86	1260	0.90	1294	0.94	1323	0.98	1349	1.02
2000	1128	0.82	1164	0.86	1201	0.89	1239	0.93	1276	0.97	1310	1.01	1336	1.06	1362	1.10
2100	1148	0.89	1185	0.93	1221	0.97	1258	1.01	1294	1.05	1325	1.09	1351	1.14	1376	1.19
2200	1170	0.97	1206	1.01	1242	1.05	1277	1.09	1311	1.14	1341	1.18	1365	1.23	1390	1.28
2300	1193	1.06	1228	1.09	1262	1.14	1295	1.19	1327	1.24	1355	1.29	1380	1.33	1406	1.37
2400	1216	1.15	1250	1.19	1282	1.24	1313	1.30	1343	1.36	1371	1.40	1396	1.44	1423	1.48

### HORIZONTAL

Air Volume cfm	External Static - in. w.g.															
	0.10		0.20		0.30		0.40		0.50		0.60		0.70		0.80	
	RPM	BHP	RPM	BHP	RPM	BHP	RPM	BHP	RPM	BHP	RPM	BHP	RPM	BHP	RPM	BHP
	Field Furnished								Drive Kit A03							
1600	712	0.29	758	0.32	807	0.36	855	0.39	906	0.43	955	0.46	997	0.50	1035	0.54
1700	766	0.32	808	0.36	850	0.40	892	0.44	936	0.47	978	0.51	1016	0.56	1052	0.60
1800	814	0.36	851	0.40	888	0.44	925	0.49	963	0.53	1000	0.57	1035	0.62	1071	0.66
1900	853	0.41	886	0.46	919	0.50	952	0.55	986	0.60	1021	0.64	1056	0.69	1091	0.73
2000	883	0.48	913	0.53	944	0.57	976	0.62	1009	0.67	1043	0.71	1078	0.76	1112	0.80
2100	906	0.56	936	0.60	967	0.65	999	0.70	1033	0.75	1067	0.79	1101	0.84	1135	0.88
2200	930	0.64	960	0.68	991	0.73	1024	0.78	1058	0.83	1092	0.88	1126	0.92	1160	0.96
2300	954	0.72	985	0.77	1017	0.82	1051	0.87	1085	0.92	1119	0.96	1152	1.00	1186	1.04
2400	981	0.81	1013	0.86	1046	0.91	1079	0.96	1113	1.00	1146	1.05	1180	1.09	1213	1.13

Air Volume cfm	External Static - in. w.g.															
	0.90		1.00		1.10		1.20		1.30		1.40		1.50		1.60	
	RPM	BHP	RPM	BHP	RPM	BHP	RPM	BHP	RPM	BHP	RPM	BHP	RPM	BHP	RPM	BHP
	Drive Kit A03								Drive Kit A07							
1600	1071	0.58	1109	0.62	1147	0.66	1186	0.69	1225	0.72	1263	0.76	1299	0.80	1334	0.83
1700	1088	0.64	1126	0.68	1164	0.72	1202	0.75	1240	0.78	1276	0.82	1311	0.86	1345	0.90
1800	1107	0.70	1143	0.74	1181	0.78	1219	0.81	1256	0.85	1291	0.89	1324	0.93	1357	0.97
1900	1126	0.77	1163	0.81	1200	0.85	1237	0.88	1273	0.92	1306	0.96	1339	1.00	1371	1.04
2000	1148	0.84	1183	0.88	1220	0.92	1257	0.96	1291	1.00	1323	1.04	1354	1.08	1385	1.12
2100	1170	0.92	1206	0.96	1242	1.00	1277	1.04	1310	1.08	1340	1.13	1371	1.17	1401	1.21
2200	1195	1.00	1230	1.04	1265	1.08	1299	1.13	1330	1.18	1359	1.23	1388	1.27	1418	1.31
2300	1220	1.08	1254	1.13	1288	1.17	1320	1.23	1350	1.28	1378	1.34	1406	1.38	1435	1.42
2400	1245	1.18	1278	1.22	1311	1.28	1341	1.33	1370	1.40	1397	1.45	1425	1.50	1454	1.54



## BLOWER DATA - BELT DRIVE - KCA072S/KCB074S - DOWNFLOW

BLOWER TABLE INCLUDES RESISTANCE FOR BASE UNIT ONLY WITH DRY INDOOR COIL AND AIR FILTERS IN PLACE.

FOR ALL UNITS ADD:

1 - Any factory installed options air resistance (economizer, wet coil, etc.) See page 40.

2 - Any field installed accessories air resistance (electric heat, duct resistance, diffuser, etc.) See page 40.

See page 40 for blower motors and drives and wet coil and options/accessory air resistance data.

Air Volume cfm	External Static - in. w.g.															
	0.10		0.20		0.30		0.40		0.50		0.60		0.70		0.80	
	RPM	BHP	RPM	BHP	RPM	BHP	RPM	BHP	RPM	BHP	RPM	BHP	RPM	BHP	RPM	BHP
	Field Furnished										Drive Kit A04					
1900	826	0.36	859	0.41	894	0.45	928	0.50	964	0.56	1000	0.61	1036	0.66	1072	0.70
2000	857	0.42	889	0.47	920	0.52	952	0.57	986	0.62	1020	0.68	1055	0.73	1091	0.77
2100	878	0.49	909	0.54	940	0.59	973	0.64	1006	0.70	1041	0.75	1076	0.80	1112	0.85
2200	897	0.55	929	0.61	961	0.66	994	0.72	1028	0.78	1063	0.83	1099	0.89	1134	0.93
2300	918	0.62	950	0.68	983	0.74	1017	0.80	1052	0.86	1087	0.92	1122	0.97	1157	1.02
2400	941	0.70	974	0.77	1008	0.83	1042	0.90	1077	0.96	1111	1.01	1146	1.06	1181	1.11
2500	966	0.79	1000	0.86	1034	0.93	1068	1.00	1103	1.06	1137	1.11	1171	1.16	1205	1.20
2600	994	0.90	1028	0.97	1062	1.04	1096	1.10	1130	1.16	1164	1.21	1197	1.26	1231	1.30
2700	1023	1.01	1057	1.08	1091	1.15	1125	1.22	1159	1.27	1192	1.32	1225	1.37	1258	1.41
2800	1053	1.13	1088	1.21	1122	1.27	1155	1.33	1188	1.39	1221	1.43	1253	1.48	1286	1.53
2900	1085	1.26	1119	1.33	1153	1.40	1186	1.45	1218	1.51	1250	1.55	1281	1.61	1313	1.66

Air Volume cfm	External Static - in. w.g.															
	0.90		1.00		1.10		1.20		1.30		1.40		1.50		1.60	
	RPM	BHP	RPM	BHP	RPM	BHP	RPM	BHP	RPM	BHP	RPM	BHP	RPM	BHP	RPM	BHP
	Drive Kit A04														Kit A08	
1900	1109	0.75	1146	0.79	1183	0.82	1221	0.86	1260	0.90	1294	0.94	1323	0.98	1349	1.02
2000	1128	0.82	1164	0.86	1201	0.89	1239	0.93	1276	0.97	1310	1.01	1336	1.06	1362	1.10
2100	1148	0.89	1185	0.93	1221	0.97	1258	1.01	1294	1.05	1325	1.09	1351	1.14	1376	1.19
2200	1170	0.97	1206	1.01	1242	1.05	1277	1.09	1311	1.14	1341	1.18	1365	1.23	1390	1.28
2300	1193	1.06	1228	1.09	1262	1.14	1295	1.19	1327	1.24	1355	1.29	1380	1.33	1406	1.37
2400	1216	1.15	1250	1.19	1282	1.24	1313	1.30	1343	1.36	1371	1.40	1396	1.44	1423	1.48
2500	1240	1.24	1273	1.29	1302	1.36	1331	1.42	1360	1.48	1388	1.52	1414	1.55	1441	1.58
2600	1265	1.34	1296	1.40	1324	1.47	1352	1.54	1381	1.60	1408	1.64	1434	1.67	1460	1.70
2700	1291	1.46	1321	1.52	1347	1.60	1374	1.67	1403	1.72	1429	1.76	1455	1.79	1481	1.82
2800	1317	1.58	1346	1.66	1372	1.74	1399	1.80	1426	1.85	1451	1.89	1477	1.92	1503	1.95
2900	1343	1.72	1371	1.80	1397	1.88	1424	1.95	1450	1.99	1475	2.02	1500	2.05	1526	2.08

## BLOWER DATA - BELT DRIVE - KCA072S/KCB074S - HORIZONTAL

BLOWER TABLE INCLUDES RESISTANCE FOR BASE UNIT ONLY WITH DRY INDOOR COIL AND AIR FILTERS IN PLACE.

FOR ALL UNITS ADD:

1 - Any factory installed options air resistance (economizer, wet coil, etc.) See page 40.

2 - Any field installed accessories air resistance (electric heat, duct resistance, diffuser, etc.) See page 40.

See page 40 for blower motors and drives and wet coil and options/accessory air resistance data.

Air Volume cfm	External Static - in. w.g.															
	0.10		0.20		0.30		0.40		0.50		0.60		0.70		0.80	
	RPM	BHP	RPM	BHP	RPM	BHP	RPM	BHP	RPM	BHP	RPM	BHP	RPM	BHP	RPM	BHP
	Field Furnished								Drive Kit A04							
1900	853	0.41	886	0.46	919	0.50	952	0.55	986	0.60	1021	0.64	1056	0.69	1091	0.73
2000	883	0.48	913	0.53	944	0.57	976	0.62	1009	0.67	1043	0.71	1078	0.76	1112	0.80
2100	906	0.56	936	0.60	967	0.65	999	0.70	1033	0.75	1067	0.79	1101	0.84	1135	0.88
2200	930	0.64	960	0.68	991	0.73	1024	0.78	1058	0.83	1092	0.88	1126	0.92	1160	0.96
2300	954	0.72	985	0.77	1017	0.82	1051	0.87	1085	0.92	1119	0.96	1152	1.00	1186	1.04
2400	981	0.81	1013	0.86	1046	0.91	1079	0.96	1113	1.00	1146	1.05	1180	1.09	1213	1.13
2500	1010	0.91	1042	0.96	1075	1.00	1109	1.05	1142	1.09	1175	1.14	1207	1.18	1239	1.23
2600	1040	1.01	1073	1.05	1106	1.10	1139	1.14	1171	1.19	1203	1.23	1235	1.28	1266	1.33
2700	1072	1.10	1104	1.15	1137	1.20	1169	1.24	1201	1.29	1232	1.34	1263	1.40	1293	1.46
2800	1105	1.21	1137	1.25	1168	1.30	1200	1.35	1231	1.40	1261	1.46	1291	1.52	1321	1.59
2900	1138	1.32	1169	1.37	1200	1.42	1231	1.47	1261	1.53	1291	1.60	1321	1.66	1350	1.73

Air Volume cfm	External Static - in. w.g.															
	0.90		1.00		1.10		1.20		1.30		1.40		1.50		1.60	
	RPM	BHP	RPM	BHP	RPM	BHP	RPM	BHP	RPM	BHP	RPM	BHP	RPM	BHP	RPM	BHP
	Drive Kit A04														Kit A08	
1900	1126	0.77	1163	0.81	1200	0.85	1237	0.88	1273	0.92	1306	0.96	1339	1.00	1371	1.04
2000	1148	0.84	1183	0.88	1220	0.92	1257	0.96	1291	1.00	1323	1.04	1354	1.08	1385	1.12
2100	1170	0.92	1206	0.96	1242	1.00	1277	1.04	1310	1.08	1340	1.13	1371	1.17	1401	1.21
2200	1195	1.00	1230	1.04	1265	1.08	1299	1.13	1330	1.18	1359	1.23	1388	1.27	1418	1.31
2300	1220	1.08	1254	1.13	1288	1.17	1320	1.23	1350	1.28	1378	1.34	1406	1.38	1435	1.42
2400	1245	1.18	1278	1.22	1311	1.28	1341	1.33	1370	1.40	1397	1.45	1425	1.50	1454	1.54
2500	1271	1.28	1303	1.33	1334	1.39	1363	1.45	1391	1.52	1418	1.57	1446	1.62	1474	1.66
2600	1297	1.39	1328	1.45	1357	1.52	1385	1.58	1412	1.64	1439	1.70	1467	1.74	1495	1.78
2700	1323	1.52	1353	1.58	1382	1.65	1409	1.72	1435	1.77	1462	1.82	1490	1.86	1517	1.90
2800	1351	1.65	1380	1.72	1407	1.78	1434	1.85	1460	1.90	1486	1.95	1513	1.99	1541	2.02
2900	1379	1.79	1407	1.86	1434	1.92	1460	1.98	1485	2.04	1511	2.08	1538	2.12	1565	2.15

## BLOWER DATA - BELT DRIVE - KCB072H/KCB074H - DOWNFLOW

**BLOWER TABLE INCLUDES RESISTANCE FOR BASE UNIT ONLY WITH DRY INDOOR COIL AND AIR FILTERS IN PLACE.**

FOR ALL UNITS ADD:

- 1 - Any factory installed options air resistance (heat section, economizer, etc.).
- 2 - Any field installed accessories air resistance (duct resistance, diffuser, etc.).

See page 39 for blower motors and drives and wet coil and options/accessory air resistance data.

Air Volume (cfm)	External Static (in.w.g.)																			
	0.10		0.20		0.30		0.40		0.50		0.60		0.70		0.80		0.9		1.0	
	RPM	BHP	RPM	BHP	RPM	BHP	RPM	BHP	RPM	BHP	RPM	BHP	RPM	BHP	RPM	BHP	RPM	BHP	RPM	BHP
	Field Furnished				Drive Kit AA01															
1900	480	0.38	512	0.44	545	0.51	579	0.57	614	0.63	648	0.7	683	0.76	719	0.83	752	0.89	781	0.95
2000	493	0.43	525	0.49	558	0.56	592	0.62	626	0.68	659	0.75	693	0.81	728	0.88	759	0.94	788	1
2100	507	0.48	539	0.54	572	0.61	605	0.67	639	0.74	671	0.8	704	0.86	737	0.93	768	0.99	795	1.04
2200	522	0.53	554	0.6	587	0.66	619	0.73	652	0.79	684	0.86	716	0.92	747	0.98	777	1.04	803	1.1
2300	537	0.59	569	0.65	602	0.72	634	0.79	666	0.85	697	0.91	728	0.98	758	1.04	786	1.1	812	1.15
2400	553	0.65	585	0.71	617	0.78	649	0.85	680	0.91	711	0.98	740	1.04	769	1.1	796	1.15	821	1.21
2500	570	0.71	602	0.78	633	0.84	665	0.91	695	0.97	725	1.04	753	1.1	781	1.16	807	1.22	832	1.27
2600	588	0.77	619	0.84	650	0.91	680	0.97	710	1.04	739	1.1	767	1.16	793	1.22	818	1.28	842	1.33
2700	607	0.84	637	0.91	667	0.97	697	1.04	726	1.11	753	1.17	780	1.23	806	1.29	830	1.35	854	1.4
2800	626	0.91	655	0.97	684	1.04	713	1.11	741	1.18	768	1.24	794	1.3	819	1.36	842	1.42	866	1.47
2900	646	0.98	674	1.05	702	1.11	730	1.18	757	1.25	783	1.32	808	1.38	832	1.44	855	1.49	878	1.54

Air Volume (cfm)	External Static (in.w.g.)																			
	1.1		1.2		1.3		1.4		1.5		1.6		1.7		1.8		1.9		2.0	
	RPM	BHP	RPM	BHP	RPM	BHP	RPM	BHP	RPM	BHP	RPM	BHP	RPM	BHP	RPM	BHP	RPM	BHP	RPM	BHP
	Drive Kit AA02				Drive Kit AA03															
1900	807	1	832	1.04	857	1.07	883	1.11	912	1.14	941	1.17	968	1.21	993	1.25	1017	1.29	1039	1.34
2000	813	1.04	838	1.08	862	1.12	889	1.15	917	1.19	945	1.22	972	1.26	997	1.3	1020	1.35	1042	1.4
2100	820	1.09	844	1.13	869	1.17	895	1.21	923	1.24	951	1.28	977	1.32	1001	1.36	1024	1.41	1046	1.46
2200	828	1.14	852	1.18	877	1.22	903	1.26	930	1.3	957	1.33	983	1.37	1006	1.42	1028	1.47	1050	1.53
2300	836	1.2	861	1.24	885	1.28	911	1.31	938	1.35	964	1.39	989	1.43	1012	1.48	1033	1.54	1054	1.6
2400	846	1.25	870	1.29	895	1.33	920	1.37	947	1.41	972	1.45	996	1.5	1018	1.55	1039	1.61	1059	1.67
2500	856	1.31	880	1.35	905	1.39	930	1.43	956	1.47	980	1.52	1003	1.57	1024	1.63	1044	1.69	1064	1.76
2600	866	1.38	891	1.42	915	1.46	940	1.5	965	1.54	988	1.59	1010	1.65	1031	1.71	1050	1.78	1069	1.84
2700	878	1.44	902	1.48	926	1.52	950	1.57	974	1.61	997	1.67	1018	1.73	1037	1.8	1056	1.87	1075	1.93
2800	889	1.51	913	1.55	937	1.59	961	1.64	984	1.69	1006	1.75	1026	1.82	1044	1.89	1063	1.96	1081	2.03
2900	902	1.58	925	1.63	949	1.67	972	1.72	994	1.78	1015	1.84	1034	1.91	1052	1.99	1069	2.06	1087	2.13

## BLOWER DATA - BELT DRIVE - KCB072H/KCB074H - HORIZONTAL

BLOWER TABLE INCLUDES RESISTANCE FOR BASE UNIT ONLY WITH DRY INDOOR COIL AND AIR FILTERS IN PLACE.

FOR ALL UNITS ADD:

1 - Any factory installed options air resistance (heat section, economizer, etc.).

2 - Any field installed accessories air resistance (duct resistance, diffuser, etc.).

See page 39 for blower motors and drives and wet coil and options/accessory air resistance data.

Air Volume (cfm)	External Static (in.w.g.)																				
	0.10		0.20		0.30		0.40		0.50		0.60		0.70		0.80		0.9		1.0		
	RPM	BHP	RPM	BHP	RPM	BHP	RPM	BHP	RPM	BHP	RPM	BHP	RPM	BHP	RPM	BHP	RPM	BHP	RPM	BHP	
	Field		Drive Kit AA01																		AA02
1900	507	0.55	538	0.58	571	0.6	604	0.63	639	0.66	673	0.7	707	0.74	740	0.78	772	0.82	802	0.86	
2000	522	0.59	554	0.62	586	0.64	620	0.67	653	0.71	687	0.74	720	0.78	752	0.82	783	0.87	812	0.91	
2100	539	0.63	571	0.66	603	0.69	636	0.72	669	0.75	702	0.79	734	0.83	765	0.88	795	0.92	823	0.97	
2200	557	0.68	588	0.71	620	0.74	652	0.77	685	0.81	717	0.84	748	0.89	778	0.93	807	0.98	834	1.03	
2300	576	0.73	607	0.76	638	0.79	670	0.83	701	0.86	733	0.9	763	0.95	792	0.99	820	1.04	846	1.09	
2400	596	0.79	626	0.82	657	0.85	688	0.89	718	0.92	749	0.96	778	1.01	806	1.06	833	1.11	858	1.16	
2500	616	0.85	645	0.88	676	0.91	706	0.95	736	0.99	765	1.03	794	1.08	821	1.13	847	1.18	871	1.23	
2600	636	0.91	665	0.94	695	0.98	724	1.02	754	1.06	782	1.1	809	1.15	836	1.2	861	1.25	885	1.3	
2700	657	0.97	685	1.01	714	1.04	743	1.08	771	1.13	799	1.17	826	1.22	851	1.27	875	1.32	899	1.37	
2800	677	1.03	706	1.07	734	1.11	762	1.16	790	1.2	816	1.25	842	1.3	867	1.35	890	1.4	913	1.45	
2900	698	1.1	726	1.14	754	1.19	781	1.23	808	1.28	834	1.33	859	1.38	883	1.43	906	1.48	928	1.54	

Air Volume (cfm)	External Static (in.w.g.)																			
	1.1		1.2		1.3		1.4		1.5		1.6		1.7		1.8		1.9		2.0	
	RPM	BHP	RPM	BHP	RPM	BHP	RPM	BHP	RPM	BHP	RPM	BHP	RPM	BHP	RPM	BHP	RPM	BHP	RPM	BHP
	Drive Kit AA02				Drive Kit AA03															
1900	830	0.91	857	0.95	883	0.99	910	1.04	937	1.09	964	1.13	991	1.18	1017	1.23	1042	1.28	1067	1.34
2000	839	0.96	865	1	891	1.05	917	1.09	944	1.14	970	1.19	996	1.24	1022	1.29	1047	1.34	1071	1.4
2100	849	1.02	874	1.06	900	1.11	926	1.15	952	1.2	978	1.25	1003	1.3	1028	1.35	1052	1.41	1075	1.46
2200	860	1.08	885	1.12	910	1.17	935	1.21	960	1.26	986	1.31	1010	1.36	1034	1.42	1058	1.48	1081	1.53
2300	871	1.14	895	1.19	920	1.23	945	1.28	969	1.33	994	1.38	1018	1.43	1042	1.49	1065	1.55	1087	1.61
2400	883	1.21	907	1.25	931	1.3	955	1.35	979	1.4	1003	1.45	1027	1.51	1050	1.57	1072	1.63	1094	1.69
2500	895	1.28	919	1.32	942	1.37	966	1.42	990	1.48	1013	1.53	1036	1.59	1059	1.65	1081	1.71	1102	1.78
2600	908	1.35	931	1.4	955	1.45	978	1.5	1001	1.56	1024	1.62	1046	1.68	1068	1.74	1089	1.8	1110	1.87
2700	922	1.43	945	1.48	967	1.53	990	1.59	1013	1.65	1035	1.71	1056	1.77	1078	1.84	1099	1.9	1119	1.96
2800	936	1.51	958	1.56	980	1.62	1003	1.68	1025	1.74	1046	1.8	1067	1.87	1088	1.93	1109	2	1129	2.06
2900	950	1.6	972	1.66	994	1.72	1016	1.78	1037	1.84	1058	1.91	1079	1.97	1099	2.04	1119	2.11	1139	2.17

## BLOWER DATA - BELT DRIVE - KCA090 - DOWNFLOW

BLOWER TABLE INCLUDES RESISTANCE FOR BASE UNIT ONLY WITH DRY INDOOR COIL AND AIR FILTERS IN PLACE.

FOR ALL UNITS ADD:

1 - Any factory installed options air resistance (economizer, wet coil, etc.)

2 - Any field installed accessories air resistance (electric heat, duct resistance, diffuser, etc.)

See page 40 for blower motors and drives and wet coil and options/accessory air resistance data.

Air Volume cfm	External Static - in. w.g.																			
	0.10		0.20		0.30		0.40		0.50		0.60		0.70		0.80		0.90		1.00	
	RPM	BHP	RPM	BHP	RPM	BHP	RPM	BHP	RPM	BHP	RPM	BHP	RPM	BHP	RPM	BHP	RPM	BHP	RPM	BHP
	Drive Kit AA01																Drive Kit AA02			
2400	553	0.65	585	0.71	617	0.78	649	0.85	680	0.91	711	0.98	740	1.04	769	1.10	796	1.15	821	1.21
2500	570	0.71	602	0.78	633	0.84	665	0.91	695	0.97	725	1.04	753	1.10	781	1.16	807	1.22	832	1.27
2600	588	0.77	619	0.84	650	0.91	680	0.97	710	1.04	739	1.10	767	1.16	793	1.22	818	1.28	842	1.33
2700	607	0.84	637	0.91	667	0.97	697	1.04	726	1.11	753	1.17	780	1.23	806	1.29	830	1.35	854	1.40
2800	626	0.91	655	0.97	684	1.04	713	1.11	741	1.18	768	1.24	794	1.30	819	1.36	842	1.42	866	1.47
2900	646	0.98	674	1.05	702	1.11	730	1.18	757	1.25	783	1.32	808	1.38	832	1.44	855	1.49	878	1.54
3000	666	1.06	693	1.12	721	1.19	747	1.26	774	1.33	799	1.40	823	1.46	846	1.52	868	1.57	891	1.62
3100	686	1.14	713	1.21	739	1.28	765	1.35	790	1.41	814	1.48	838	1.55	860	1.61	882	1.66	904	1.70
3200	707	1.22	732	1.29	758	1.36	783	1.43	807	1.50	830	1.57	853	1.64	874	1.70	896	1.75	918	1.79
3300	727	1.31	752	1.38	776	1.46	800	1.53	823	1.60	846	1.67	868	1.73	889	1.79	911	1.84	932	1.89
3400	747	1.41	771	1.48	794	1.55	817	1.63	840	1.70	862	1.77	883	1.83	904	1.89	925	1.94	947	1.98
3500	767	1.51	790	1.58	812	1.66	835	1.73	856	1.80	878	1.87	899	1.93	920	1.99	940	2.04	961	2.08
3600	786	1.61	808	1.69	830	1.77	852	1.84	873	1.91	894	1.98	915	2.04	935	2.09	955	2.14	975	2.19

Air Volume cfm	External Static - in. w.g.																			
	0.90		1.00		1.30		1.40		1.50		1.60		1.70		1.80		1.90		2.00	
	RPM	BHP	RPM	BHP	RPM	BHP	RPM	BHP	RPM	BHP	RPM	BHP	RPM	BHP	RPM	BHP	RPM	BHP	RPM	BHP
	Drive Kit AA02				Drive Kit AA03															
2400	846	1.25	870	1.29	895	1.33	920	1.37	947	1.41	972	1.45	996	1.50	1018	1.55	1039	1.61	1059	1.67
2500	856	1.31	880	1.35	905	1.39	930	1.43	956	1.47	980	1.52	1003	1.57	1024	1.63	1044	1.69	1064	1.76
2600	866	1.38	891	1.42	915	1.46	940	1.50	965	1.54	988	1.59	1010	1.65	1031	1.71	1050	1.78	1069	1.84
2700	878	1.44	902	1.48	926	1.52	950	1.57	974	1.61	997	1.67	1018	1.73	1037	1.80	1056	1.87	1075	1.93
2800	889	1.51	913	1.55	937	1.59	961	1.64	984	1.69	1006	1.75	1026	1.82	1044	1.89	1063	1.96	1081	2.03
2900	902	1.58	925	1.63	949	1.67	972	1.72	994	1.78	1015	1.84	1034	1.91	1052	1.99	1069	2.06	1087	2.13
3000	914	1.66	938	1.71	961	1.75	983	1.81	1004	1.87	1024	1.94	1042	2.01	1059	2.09	1076	2.16	1093	2.23
3100	927	1.75	950	1.79	972	1.84	994	1.90	1014	1.96	1033	2.04	1050	2.11	1067	2.19	1083	2.27	1100	2.34
3200	941	1.84	963	1.88	984	1.94	1005	2.00	1024	2.07	1042	2.14	1059	2.23	1075	2.31	1091	2.39	1107	2.46
3300	954	1.93	976	1.98	996	2.04	1016	2.10	1035	2.18	1052	2.26	1067	2.35	1083	2.43	1098	2.51	1114	2.59
3400	968	2.03	989	2.08	1008	2.14	1027	2.22	1045	2.30	1061	2.38	1076	2.47	1091	2.57	1106	2.65	1121	2.73
3500	982	2.13	1001	2.19	1020	2.26	1038	2.33	1054	2.42	1070	2.51	1084	2.61	1099	2.71	1113	2.79	1128	2.87
3600	995	2.24	1014	2.30	1031	2.38	1048	2.46	1064	2.55	1079	2.65	1093	2.76	1107	2.86	1121	2.95	1136	3.03

Drive Kit - AA03				Drive Kit - AA04															
------------------	--	--	--	------------------	--	--	--	--	--	--	--	--	--	--	--	--	--	--	--

## BLOWER DATA - BELT DRIVE - KCA090 - HORIZONTAL

BLOWER TABLE INCLUDES RESISTANCE FOR BASE UNIT ONLY WITH DRY INDOOR COIL AND AIR FILTERS IN PLACE.

FOR ALL UNITS ADD:

- 1 - Any factory installed options air resistance (economizer, wet coil, etc.)
- 2 - Any field installed accessories air resistance (electric heat, duct resistance, diffuser, etc.)

See page 40 for blower motors and drives and wet coil and options/accessory air resistance data.

Air Volume cfm	External Static - in. w.g.																			
	0.10		0.20		0.30		0.40		0.50		0.60		0.70		0.80		0.90		1.00	
	RPM	BHP	RPM	BHP	RPM	BHP	RPM	BHP	RPM	BHP	RPM	BHP	RPM	BHP	RPM	BHP	RPM	BHP	RPM	BHP
	Drive Kit AA01										Drive Kit AA02									
2400	596	0.79	626	0.82	657	0.85	688	0.89	718	0.92	749	0.96	778	1.01	806	1.06	833	1.11	858	1.16
2500	616	0.85	645	0.88	676	0.91	706	0.95	736	0.99	765	1.03	794	1.08	821	1.13	847	1.18	871	1.23
2600	636	0.91	665	0.94	695	0.98	724	1.02	754	1.06	782	1.10	809	1.15	836	1.20	861	1.25	885	1.30
2700	657	0.97	685	1.01	714	1.04	743	1.08	771	1.13	799	1.17	826	1.22	851	1.27	875	1.32	899	1.37
2800	677	1.03	706	1.07	734	1.11	762	1.16	790	1.20	816	1.25	842	1.30	867	1.35	890	1.40	913	1.45
2900	698	1.10	726	1.14	754	1.19	781	1.23	808	1.28	834	1.33	859	1.38	883	1.43	906	1.48	928	1.54
3000	720	1.17	747	1.22	774	1.26	801	1.31	826	1.36	851	1.41	876	1.46	899	1.52	921	1.57	943	1.63
3100	741	1.25	768	1.30	794	1.35	820	1.40	845	1.45	869	1.50	893	1.56	915	1.61	937	1.67	959	1.73
3200	763	1.34	789	1.39	815	1.44	840	1.49	864	1.54	888	1.60	910	1.66	932	1.72	954	1.78	975	1.84
3300	785	1.43	811	1.48	836	1.53	860	1.59	883	1.65	906	1.71	928	1.77	950	1.83	970	1.90	991	1.96
3400	807	1.53	832	1.58	856	1.64	880	1.70	903	1.76	925	1.82	946	1.88	967	1.95	987	2.02	1007	2.09
3500	830	1.63	854	1.69	877	1.75	900	1.81	922	1.88	944	1.94	964	2.01	985	2.08	1004	2.15	1024	2.23
3600	852	1.74	876	1.81	898	1.87	921	1.94	942	2.01	963	2.07	983	2.15	1002	2.22	1022	2.29	1041	2.37
	External Static - in. w.g.																			
	0.90		1.00		1.30		1.40		1.50		1.60		1.70		1.80		1.90		2.00	
	RPM	BHP	RPM	BHP	RPM	BHP	RPM	BHP	RPM	BHP	RPM	BHP	RPM	BHP	RPM	BHP	RPM	BHP	RPM	BHP
	Drive Kit AA03																			
2400	883	1.21	907	1.25	931	1.30	955	1.35	979	1.40	1003	1.45	1027	1.51	1050	1.57	1072	1.63	1094	1.69
2500	895	1.28	919	1.32	942	1.37	966	1.42	990	1.48	1013	1.53	1036	1.59	1059	1.65	1081	1.71	1102	1.78
2600	908	1.35	931	1.40	955	1.45	978	1.50	1001	1.56	1024	1.62	1046	1.68	1068	1.74	1089	1.80	1110	1.87
2700	922	1.43	945	1.48	967	1.53	990	1.59	1013	1.65	1035	1.71	1056	1.77	1078	1.84	1099	1.90	1119	1.96
2800	936	1.51	958	1.56	980	1.62	1003	1.68	1025	1.74	1046	1.80	1067	1.87	1088	1.93	1109	2.00	1129	2.06
2900	950	1.60	972	1.66	994	1.72	1016	1.78	1037	1.84	1058	1.91	1079	1.97	1099	2.04	1119	2.11	1139	2.17
3000	965	1.69	986	1.76	1008	1.82	1029	1.88	1050	1.95	1070	2.02	1091	2.08	1110	2.15	1130	2.22	1149	2.28
3100	980	1.80	1001	1.86	1022	1.93	1043	2.00	1063	2.07	1083	2.13	1103	2.20	1122	2.27	1141	2.33	1160	2.40
3200	995	1.91	1016	1.98	1036	2.05	1057	2.12	1077	2.19	1096	2.26	1116	2.33	1134	2.39	1153	2.46	1171	2.52
3300	1011	2.03	1031	2.11	1051	2.18	1071	2.25	1091	2.32	1110	2.39	1129	2.45	1147	2.52	1165	2.59	1183	2.65
3400	1027	2.16	1047	2.24	1067	2.31	1086	2.38	1105	2.45	1124	2.52	1142	2.59	1160	2.66	1178	2.72	1196	2.78
3500	1043	2.30	1063	2.38	1082	2.45	1101	2.52	1120	2.59	1138	2.66	1156	2.73	1174	2.80	1191	2.86	1208	2.92
3600	1060	2.45	1079	2.52	1098	2.60	1117	2.67	1135	2.74	1153	2.81	1170	2.87	1188	2.94	1205	3.00	1222	3.06
	Drive Kit AA04																			

## BLOWER DATA

### BELT DRIVE KIT SPECIFICATIONS - 036-074S

Model No.	Motor HP		No. of Speeds	Drive Kits and RPM Range							
	Nominal	Maximum		A01	A02	A03	A04	A05	A06	A07	A08
036	0.75	0.86	1	673-1010	---	---	---	897-1346	---	---	---
	1	1.15	1	673-1010	---	---	---	897-1346	---	---	---
	1.5	1.7	1	673-1010	---	---	---	897-1346	---	---	---
	2	2.3	1	673-1010	---	---	---	897-1346	---	---	---
048	0.75	0.86	1	---	745-1117	---	---	---	1071-1429	---	---
	1	1.15	1	---	745-1117	---	---	---	1071-1429	---	---
	1.5	1.7	1	---	745-1117	---	---	---	1071-1429	---	---
	2	2.3	1	---	745-1117	---	---	---	1071-1429	---	---
060	0.75	0.86	1	---	---	833-1250	---	---	---	1212-1548	---
	1	1.15	1	---	---	833-1250	---	---	---	1212-1548	---
	1.5	1.7	1	---	---	833-1250	---	---	---	1212-1548	---
	2	2.3	1	---	---	833-1250	---	---	---	1212-1548	---
072S	1	1.5	1	---	---	---	968-1340	---	---	---	1193-1591
	2	2.3	1	---	---	---	968-1340	---	---	---	1193-1591
074S	1	1.5	2	---	---	---	968-1340	---	---	---	1193-1591
	2	2.3	2	---	---	---	968-1340	---	---	---	1193-1591

NOTE - Using total air volume and system static pressure requirements determine from blower performance tables rpm and motor hp required. Maximum usable hp of motors furnished are shown. In Canada, nominal motor hp is also maximum usable motor hp. If motors of comparable hp are used, be sure to keep within the service factor limitations outlined on the motor nameplate.

### BELT DRIVE KIT SPECIFICATIONS - 072H/074H/090

Model No.	Motor HP		No. of Speeds	Drive Kits and RPM Range			
	Nominal	Maximum		AA01	AA02	AA03	AA04
072H	1	1.15	1	522-784	632-875	798-1105	---
	2	2.3	1	522-784	632-875	798-1105	---
074H	1	1.15	2	522-784	632-875	798-1105	---
	2	2.3	2	522-784	632-875	798-1105	---
090	1	1.15	1	522-784	---	---	---
	2	2.3	1	---	632-875	798-1105	---
	3	3.45	1	---	---	---	921-1228

NOTE - Using total air volume and system static pressure requirements determine from blower performance tables rpm and motor hp required. Maximum usable hp of motors furnished are shown. In Canada, nominal motor hp is also maximum usable motor hp. If motors of comparable hp are used, be sure to keep within the service factor limitations outlined on the motor nameplate.

## BLOWER DATA

### OPTIONS / ACCESSORIES AIR RESISTANCE FOR 024-074 MODELS - in. w.g.

Air Volume cfm	Wet Indoor Coil			Economizer	Electric Heat	Filters	
	036-048	060	072/074			MERV 8	MERV 13
800	0.01	0.01	0.01	0.04	0.01	0.04	0.05
1000	0.02	0.02	0.01	0.04	0.03	0.04	0.07
1200	0.03	0.04	0.02	0.04	0.06	0.04	0.07
1400	0.04	0.05	0.03	0.04	0.09	0.04	0.07
1600	0.05	0.06	0.04	0.04	0.12	0.04	0.07
1800	0.06	0.07	0.05	0.05	0.15	0.05	0.07
2000	0.08	0.09	0.06	0.05	0.18	0.05	0.08
2200	0.09	0.10	0.07	0.05	0.20	0.05	0.08
2400	0.10	0.12	0.08	0.05	0.22	0.05	0.08
2600	0.11	0.13	0.09	0.06	0.24	0.05	0.08
2800	0.13	0.15	0.10	0.06	0.26	0.05	0.08
3000	0.14	0.16	0.12	0.06	0.28	0.05	0.08

### OPTIONS / ACCESSORIES AIR RESISTANCE FOR 090 MODELS - in. w.g.

Air Volume cfm	Wet Indoor Coil	Economizer	Electric Heat	Filters	
				MERV 8	MERV 13
2400	0.08	0.05	0.22	0.05	0.08
2600	0.09	0.06	0.24	0.05	0.08
2800	0.10	0.06	0.26	0.05	0.08
3000	0.11	0.06	0.28	0.05	0.08
3200	0.12	0.06	0.30	0.06	0.09
3400	0.14	0.06	0.32	0.06	0.09
3600	0.15	0.06	0.34	0.06	0.10

### POWER EXHAUST FAN PERFORMANCE

Return Air System Static Pressure - in. w.g.	Air Volume Exhausted cfm
0.00	2000
0.05	1990
0.10	1924
0.15	1810
0.20	1664
0.25	1507
0.30	1350
0.35	1210



## BLOWER DATA

### CEILING DIFFUSERS AIR RESISTANCE (in. w.g.)

Air Volume cfm	RTD9-65S Step-Down Diffuser			FD9-65S Flush Diffuser	RTD11-95S Step-Down Diffuser			FD11-95S Flush Diffuser
	2 Ends Open	1 Side & 2 Ends Open	All Ends & Sides Open		2 Ends Open	1 Side & 2 Ends Open	All Ends & Sides Open	
800	0.15	0.13	0.11	0.11	---	---	---	---
1000	0.19	0.16	0.14	0.14	---	---	---	---
1200	0.25	0.20	0.17	0.17	---	---	---	---
1400	0.33	0.26	0.20	0.20	---	---	---	---
1600	0.43	0.32	0.20	0.24	---	---	---	---
1800	0.56	0.40	0.30	0.30	0.13	0.11	0.09	0.09
2000	0.73	0.50	0.36	0.36	0.15	0.13	0.11	0.10
2200	0.95	0.63	0.44	0.44	0.18	0.15	0.12	0.12
2400	---	----	---	---	0.21	0.18	0.15	0.14
2600	---	----	---	---	0.24	0.21	0.18	0.17
2800	---	----	---	---	0.27	0.24	0.21	0.20
3000	---	----	---	---	0.32	0.29	0.25	0.25
3200	---	----	---	---	0.41	0.37	0.32	0.31
3400	---	----	---	---	0.50	0.45	0.39	0.37
3600	---	----	---	---	0.61	0.54	0.48	0.44

### CEILING DIFFUSER AIR THROW DATA

Air Volume - cfm	<sup>1</sup> Effective Throw - ft.	
	Model No.	Model No.
	<b>RTD9-65S</b>	<b>FD9-65S</b>
800	10 - 17	14 - 18
1000	10 - 17	15 - 20
1200	11 - 18	16 - 22
1400	12 - 19	17 - 24
1600	12 - 20	18 - 25
1800	13 - 21	20 - 28
2000	14 - 23	21 - 29
2200	16 - 25	22 - 30
	<b>RTD11-95S</b>	<b>FD11-95S</b>
2600	24 - 29	19 - 24
2800	25 - 30	20 - 28
3000	27 - 33	21 - 29
3200	28 - 35	22 - 29
3400	30 - 37	22 - 30
3600	25 - 33	22 - 24

<sup>1</sup> Effective throw based on terminal velocities of 75 ft. per minute.

## OUTDOOR SOUND DATA

Unit Model No.	Octave Band Linear Sound Power Levels dBA, re 10 <sup>-12</sup> Watts - Center Frequency - Hz							<sup>1</sup> Sound Rating Number (SRN) (dBA)
	125	250	500	1000	2000	4000	8000	
<b>KCA036 and 048</b>	63	66	70	71	68	62	53	75
<b>KCA060</b>	67	72	77	76	73	68	61	82
<b>KCA072</b>	66	71	74	73	70	65	57	79
<b>KCA090</b>	66	71	73	74	70	65	57	79
<b>KCB024, 030, 036, 048</b>	61	65	70	67	64	58	49	74
<b>KCB060</b>	66	71	74	73	70	65	57	79
<b>KCB072, 074</b>	66	71	74	73	70	65	57	79

Note - The octave sound power data does not include tonal corrections.

<sup>1</sup> Sound Rating Number according to ARI Standard 270-95 (includes pure tone penalty). "SRN" is the overall A-Weighted Sound Power Level, (LWA), dBA (100 Hz to 10,000 Hz).

**ELECTRICAL/ELECTRIC HEAT DATA - KCB****2 - 2.5 TON**

DIRECT DRIVE BLOWER		KCB024S	KCB030S
<sup>1</sup> Voltage - 60hz		208/230V - 1 Ph	208/230V - 1 Ph
Compressor 1	Rated Load Amps	9.8	12.7
	Locked Rotor Amps	47	64
Outdoor Fan Motors (1)	Full Load Amps (total)	1.7	1.7
Service Outlet 115V GFI (amps)		15	15
Indoor Blower Motor	Horsepower	0.25	0.25
	Type	Direct	Direct
	Full Load Amps	1.8	1.8
<sup>2</sup> Maximum Overcurrent Protection	Unit Only	25	30
<sup>3</sup> Minimum Circuit Ampacity	Unit Only	16	20

**ELECTRIC HEAT DATA**

Electric Heat Voltage			208V	240V	208V	240V
<sup>2</sup> Maximum Overcurrent Protection	Unit + Electric Heat	5 kW	25	30	30	30
		7.5 kW	40	45	40	45
		10 kW	50	60	50	60
<sup>3</sup> Minimum Circuit Ampacity	Unit + Electric Heat	5 kW	25	29	25	29
		7.5 kW	37	42	37	42
		10 kW	48	55	48	55

**ELECTRICAL ACCESSORIES**

Disconnect	Standard Access - 0-10 kW	20W15	20W15	20W15	20W15
	Hinged Access - 0-10 kW	20W21	20W21	20W21	20W21

NOTE - All units have a minimum Short Circuit Current Rating (SCCR) of 5000 amps.

<sup>1</sup> Extremes of operating range are plus and minus 10% of line voltage.<sup>2</sup> HACR type breaker or fuse.<sup>3</sup> Refer to National or Canadian Electrical Code manual to determine wire, fuse and disconnect size requirements.

**ELECTRICAL/ELECTRIC HEAT DATA - KCB**
**3 TON**
**KCB036S - DIRECT DRIVE BOWER**

<sup>1</sup> Voltage - 60hz		208/230V - 1 Ph	208/230V - 3 Ph	460V - 3 Ph	575V - 3 Ph
Compressor	Rated Load Amps	15.3	8.7	4	3.6
	Locked Rotor Amps	70	70	31	27
Outdoor Fan Motor	Full Load Amps	1.7	1.7	1.1	0.7
Power Exhaust (1) 0.33 HP	Full Load Amps	2.4	2.4	1.3	1
Service Outlet 115V GFI (amps)		15	15	15	20
Indoor Blower Motor	Horsepower	0.5	0.5	0.5	0.5
	Type	Direct	Direct	Direct	Direct
	Full Load Amps	3.9	3.9	2	2
<sup>2</sup> Maximum Overcurrent Protection	Unit Only	40	25	15	15
	with (1) 0.33 HP Power Exhaust	40	25	15	15
<sup>3</sup> Minimum Circuit Ampacity	Unit Only	25	17	9	8
	with (1) 0.33 HP Power Exhaust	28	19	10	9

**ELECTRIC HEAT DATA**

Electric Heat Voltage			208V	240V	208V	240V	480V	600V
<sup>2</sup> Maximum Overcurrent Protection	Unit + Electric Heat	7.5 kW	40	45	25	30	15	15
		15 kW	80	90	45	50	30	25
<sup>3</sup> Minimum Circuit Ampacity	Unit + Electric Heat	7.5 kW	39	44	25	28	14	12
		15 kW	73	83	44	50	26	21
<sup>2</sup> Maximum Overcurrent Protection	Unit + Electric Heat + Power Exhaust	7.5 kW	45	50	30	35	20	15
		15 kW	80	90	50	60	30	25
<sup>3</sup> Minimum Circuit Ampacity	Unit + Electric Heat + Power Exhaust	7.5 kW	42	47	28	31	16	13
		15 kW	76	86	47	53	27	22

**ELECTRICAL ACCESSORIES**

Disconnect	Standard Access - 0-15 kW	20W15	20W15	20W15	20W15
	Hinged Access - 0-15 kW	20W21	20W21	20W21	20W21

NOTE - All units have a minimum Short Circuit Current Rating (SCCR) of 5000 amps.

<sup>1</sup> Extremes of operating range are plus and minus 10% of line voltage.

<sup>2</sup> HACR type breaker or fuse.

<sup>3</sup> Refer to National or Canadian Electrical Code manual to determine wire, fuse and disconnect size requirements.

**ELECTRICAL/ELECTRIC HEAT DATA - KCB**
**4 TON**
**KCB048S - DIRECT DRIVE BOWER**

<sup>1</sup> Voltage - 60hz		208/230V - 1 Ph	208/230V - 3 Ph	460V - 3 Ph	575V - 3 Ph
Compressor	Rated Load Amps	20	11	5.5	4.7
	Locked Rotor Amps	99	86	37	34
Outdoor Fan Motor	Full Load Amps	1.7	1.7	1.1	0.7
Power Exhaust (1) 0.33 HP	Full Load Amps	2.4	2.4	1.3	1
Service Outlet 115V GFI (amps)		15	15	15	20
Indoor Blower Motor	Horsepower	0.5	0.5	0.5	0.5
	Type	Direct	Direct	Direct	Direct
	Full Load Amps	3.9	3.9	2	2
<sup>2</sup> Maximum Overcurrent Protection	Unit Only	50	30	15	15
	with (1) 0.33 HP Power Exhaust	50	30	15	15
<sup>3</sup> Minimum Circuit Ampacity	Unit Only	31	20	10	9
	with (1) 0.33 HP Power Exhaust	33	22	12	10

**ELECTRIC HEAT DATA**

Electric Heat Voltage			208V	240V	208V	240V	480V	600V
<sup>2</sup> Maximum Overcurrent Protection	Unit + Electric Heat	<b>7.5 kW</b>	50	50	30	30	15	15
		<b>15 kW</b>	80	90	45	50	30	25
<sup>3</sup> Minimum Circuit Ampacity	Unit + Electric Heat	<b>7.5 kW</b>	39	44	25	28	14	12
		<b>15 kW</b>	73	83	44	50	26	21
<sup>2</sup> Maximum Overcurrent Protection	Unit + Electric Heat + Power Exhaust	<b>7.5 kW</b>	50	50	30	35	20	15
		<b>15 kW</b>	80	90	50	60	30	25
<sup>3</sup> Minimum Circuit Ampacity	Unit + Electric Heat + Power Exhaust	<b>7.5 kW</b>	42	47	28	31	16	13
		<b>15 kW</b>	76	86	47	53	27	22

**ELECTRICAL ACCESSORIES**

Disconnect	Standard Access - 0-15 kW	<b>20W15</b>	<b>20W15</b>	<b>20W15</b>	<b>20W15</b>
	Hinged Access - 0-15 kW	<b>20W21</b>	<b>20W21</b>	<b>20W21</b>	<b>20W21</b>

NOTE - All units have a minimum Short Circuit Current Rating (SCCR) of 5000 amps.

<sup>1</sup> Extremes of operating range are plus and minus 10% of line voltage.

<sup>2</sup> HACR type breaker or fuse.

<sup>3</sup> Refer to National or Canadian Electrical Code manual to determine wire, fuse and disconnect size requirements.

**ELECTRICAL/ELECTRIC HEAT DATA - KCB**

**5 TON**

**KCB060S - DIRECT DRIVE BOWER**

<sup>1</sup> Voltage - 60hz		208/230V - 1 Ph	208/230V - 3 Ph	460V - 3 Ph	575V - 3 Ph
Compressor	Rated Load Amps	22.1	13.5	8	5
	Locked Rotor Amps	125	109	59	40
Outdoor Fan Motor	Full Load Amps	2.4	2.4	1.3	1
Power Exhaust (1) 0.33 HP	Full Load Amps	2.4	2.4	1.3	1
Service Outlet 115V GFI (amps)		15	15	15	20
Indoor Blower Motor	Horsepower	0.75	0.75	0.75	0.75
	Type	Direct	Direct	Direct	Direct
	Full Load Amps	4.9	4.9	2.5	2.5
<sup>2</sup> Maximum Overcurrent Protection	Unit Only	50	35	20	15
	with (1) 0.33 HP Power Exhaust	50	40	20	15
<sup>3</sup> Minimum Circuit Ampacity	Unit Only	35	25	14	10
	with (1) 0.33 HP Power Exhaust	38	27	16	11

**ELECTRIC HEAT DATA**

Electric Heat Voltage				208V	240V	208V	240V	480V	600V
<sup>2</sup> Maximum Overcurrent Protection	Unit + Electric Heat	7.5 kW	7.5 kW	50	50	35	35	20	15
		15 kW	15 kW	80	90	50	60	30	25
		22.5 kW	22.5 kW	110	125	70	80	40	35
<sup>3</sup> Minimum Circuit Ampacity	Unit + Electric Heat	7.5 kW	7.5 kW	40	46	26	29	15	13
		15 kW	15 kW	74	85	46	52	26	22
		22.5 kW	22.5 kW	108	124	65	74	37	31
<sup>2</sup> Maximum Overcurrent Protection	Unit + Electric Heat + Power Exhaust	7.5 kW	7.5 kW	50	50	40	40	20	15
		15 kW	15 kW	80	90	50	60	30	25
		22.5 kW	22.5 kW	125	150	70	80	40	35
<sup>3</sup> Minimum Circuit Ampacity	Unit + Electric Heat + Power Exhaust	7.5 kW	7.5 kW	43	49	29	32	17	14
		15 kW	15 kW	77	88	49	55	28	23
		22.5 kW	22.5 kW	111	127	68	77	39	32

**ELECTRICAL ACCESSORIES**

Disconnect	Standard Access - 0-7.5 kW	20W18	20W18	20W18	20W18
		15-22.5 kW	20W19	20W18	20W18
	Hinged Access - 0-7.5 kW	20W24	20W24	20W24	20W24
		15-22.5 kW	20W25	20W24	20W24

NOTE - All units have a minimum Short Circuit Current Rating (SCCR) of 5000 amps.

<sup>1</sup> Extremes of operating range are plus and minus 10% of line voltage.

<sup>2</sup> HACR type breaker or fuse.

<sup>3</sup> Refer to National or Canadian Electrical Code manual to determine wire, fuse and disconnect size requirements.

**ELECTRICAL/ELECTRIC HEAT DATA - KCB**
**3 TON**
**KCB036S - BELT DRIVE BLOWER**

<sup>1</sup> Voltage - 60hz		208/230V - 1 Ph		208/230V - 3 Ph		460V - 3 Ph		575V - 3 Ph	
Compressor	Rated Load Amps	15.3		8.7		4		3.6	
	Locked Rotor Amps	70		70		31		27	
Outdoor Fan Motor	Full Load Amps	1.7		1.7		1.1		0.7	
Power Exhaust (1) 0.33 HP	Full Load Amps	2.4		2.4		1.3		1	
Service Outlet 115V GFI (amps)		15		15		15		20	
Indoor Blower Motor	Horsepower	0.75	1.5	1	2	1	2	1	2
	Type	Belt	Belt	Belt	Belt	Belt	Belt	Belt	Belt
	Full Load Amps	7.6	11	4.6	7.5	2.1	3.4	1.7	2.7
<sup>2</sup> Maximum Overcurrent Protection	Unit Only	40	45	25	25	15	15	15	15
	with (1) 0.33 HP Power Exhaust	45	45	25	30	15	15	15	15
<sup>3</sup> Minimum Circuit Ampacity	Unit Only	29	32	18	21	9	10	7	8
	with (1) 0.33 HP Power Exhaust	31	35	20	23	10	11	8	9

**ELECTRIC HEAT DATA**

Electric Heat Voltage			208V	240V	208V	240V	208V	240V	208V	240V	480V	480V	600V	600V
<sup>2</sup> Maximum Overcurrent Protection	Unit + Electric Heat	<b>7.5 kW</b>	45	50	50	60	30	30	30	35	15	20	15	15
		<b>15 kW</b>	80	90	90	100	45	60	50	60	30	30	25	25
<sup>3</sup> Minimum Circuit Ampacity	Unit + Electric Heat	<b>7.5 kW</b>	44	49	48	53	26	29	29	32	14	16	12	13
		<b>15 kW</b>	78	88	82	92	45	51	49	55	26	27	21	22
<sup>2</sup> Maximum Overcurrent Protection	Unit + Electric Heat + Power Exhaust	<b>7.5 kW</b>	50	60	60	60	30	35	35	35	20	20	15	15
		<b>15 kW</b>	90	100	4 90	100	50	60	60	60	30	30	25	25
<sup>3</sup> Minimum Circuit Ampacity	Unit + Electric Heat + Power Exhaust	<b>7.5 kW</b>	47	52	51	56	29	32	32	35	16	18	13	14
		<b>15 kW</b>	81	91	85	95	48	54	52	58	27	29	22	23

**ELECTRICAL ACCESSORIES**

Disconnect	Standard Access -	0-7.5 kW	20W15	20W15	20W15	20W15	20W15
		15 kW	20W16	20W15	20W15	20W15	20W15
	Hinged Access -	0-7.5 kW	20W21	20W21	20W21	20W21	20W21
		15 kW	20W22	20W21	20W21	20W21	20W21

NOTE - All units have a minimum Short Circuit Current Rating (SCCR) of 5000 amps.

<sup>1</sup> Extremes of operating range are plus and minus 10% of line voltage.

<sup>2</sup> HACR type breaker or fuse.

<sup>3</sup> Refer to National or Canadian Electrical Code manual to determine wire, fuse and disconnect size requirements.

**ELECTRICAL/ELECTRIC HEAT DATA - KCB**
**4 TON**
**KCB048S - BELT DRIVE BLOWER**

<sup>1</sup> Voltage - 60hz		208/230V - 1 Ph		208/230V - 3 Ph		460V - 3 Ph		575V - 3 Ph	
Compressor	Rated Load Amps	20		11		5.5		4.7	
	Locked Rotor Amps	99		86		37		34	
Outdoor Fan Motor	Full Load Amps	1.7		1.7		1.1		0.7	
Power Exhaust (1) 0.33 HP	Full Load Amps	2.4		2.4		1.3		1	
Service Outlet 115V GFI (amps)		15		15		15		20	
Indoor Blower Motor	Horsepower	0.75	1.5	1	2	1	2	1	2
	Type	Belt	Belt	Belt	Belt	Belt	Belt	Belt	Belt
	Full Load Amps	7.6	11	4.6	7.5	2.1	3.4	1.7	2.7
<sup>2</sup> Maximum Overcurrent Protection	Unit Only	50	50	30	30	15	15	15	15
	with (1) 0.33 HP Power Exhaust	50	60	30	35	15	15	15	15
<sup>3</sup> Minimum Circuit Ampacity	Unit Only	35	38	21	23	11	12	9	10
	with (1) 0.33 HP Power Exhaust	37	41	23	26	12	13	10	11

**ELECTRIC HEAT DATA**

Electric Heat Voltage			208V	240V	208V	240V	208V	240V	208V	240V	480V	480V	600V	600V
<sup>2</sup> Maximum Overcurrent Protection	Unit + Electric Heat	7.5 kW	50	50	50	60	30	30	30	35	15	20	15	15
		15 kW	80	90	90	100	45	60	50	60	30	30	25	25
<sup>3</sup> Minimum Circuit Ampacity	Unit + Electric Heat	7.5 kW	44	49	48	53	26	29	29	32	14	16	12	13
		15 kW	78	88	82	92	45	51	49	55	26	27	21	22
<sup>2</sup> Maximum Overcurrent Protection	Unit + Electric Heat + Power Exhaust	7.5 kW	50	60	60	60	30	35	35	35	20	20	15	15
		15 kW	90	100	90	100	50	60	60	60	30	30	25	25
<sup>3</sup> Minimum Circuit Ampacity	Unit + Electric Heat + Power Exhaust	7.5 kW	47	52	51	56	29	32	32	35	16	18	13	14
		15 kW	81	91	85	95	48	54	52	58	27	29	22	23

**ELECTRICAL ACCESSORIES**

Disconnect	Standard Access - 0-7.5 kW	20W15	20W15	20W15	20W15	20W15
	15 kW	20W16	20W15	20W15	20W15	20W15
	Hinged Access - 0-7.5 kW	20W21	20W21	20W21	20W21	20W21
	15 kW	20W22	20W21	20W21	20W21	20W21

NOTE - All units have a minimum Short Circuit Current Rating (SCCR) of 5000 amps.

<sup>1</sup> Extremes of operating range are plus and minus 10% of line voltage.

<sup>2</sup> HACR type breaker or fuse.

<sup>3</sup> Refer to National or Canadian Electrical Code manual to determine wire, fuse and disconnect size requirements.

**ELECTRICAL/ELECTRIC HEAT DATA - KCB**
**5 TON**
**KCB060S - BELT DRIVE BLOWER**

<sup>1</sup> Voltage - 60hz		208/230V - 1 Ph		208/230V - 3 Ph		460V - 3 Ph		575V - 3 Ph	
Compressor	Rated Load Amps	22.1		13.5		8		5	
	Locked Rotor Amps	125		109		59		40	
Outdoor Fan Motor	Full Load Amps	2.4		2.4		1.3		1	
Power Exhaust (1) 0.33 HP	Full Load Amps	2.4		2.4		1.3		1	
Service Outlet 115V GFI (amps)		15		15		15		20	
Indoor Blower Motor	Horsepower	0.75	1.5	1	2	1	2	1	2
	Type	Belt	Belt	Belt	Belt	Belt	Belt	Belt	Belt
	Full Load Amps	7.6	11	4.6	7.5	2.1	3.4	1.7	2.7
<sup>2</sup> Maximum Overcurrent Protection	Unit Only	50	60	35	40	20	20	15	15
	with (1) 0.33 HP Power Exhaust	60	60	35	40	20	20	15	15
<sup>3</sup> Minimum Circuit Ampacity	Unit Only	38	42	24	27	14	15	9	10
	with (1) 0.33 HP Power Exhaust	41	44	27	30	15	16	10	11

**ELECTRIC HEAT DATA**

Electric Heat Voltage			208V	240V	208V	240V	208V	240V	208V	240V	480V	480V	600V	600V
<sup>2</sup> Maximum Overcurrent Protection	Unit + Electric Heat	7.5 kW	50	50	60	60	35	35	40	40	20	20	15	15
		15 kW	80	90	90	100	45	60	50	60	30	30	25	25
		22.5 kW	125	150	125	150	70	80	70	80	40	40	30	35
<sup>3</sup> Minimum Circuit Ampacity	Unit + Electric Heat	7.5 kW	44	49	48	53	26	29	29	32	14	16	12	13
		15 kW	78	88	82	92	45	51	49	55	26	27	21	22
		22.5 kW	112	127	116	131	65	74	69	78	37	39	30	31
<sup>2</sup> Maximum Overcurrent Protection	Unit + Electric Heat + Power Exhaust	7.5 kW	60	60	60	60	35	35	40	40	20	20	15	15
		15 kW	90	100	90	100	50	60	60	60	30	30	25	25
		22.5 kW	125	150	125	150	70	80	80	90	40	40	35	35
<sup>3</sup> Minimum Circuit Ampacity	Unit + Electric Heat + Power Exhaust	7.5 kW	47	52	51	56	29	32	32	35	16	18	13	14
		15 kW	81	91	85	95	48	54	52	58	27	29	22	23
		22.5 kW	115	130	119	134	68	77	72	81	39	40	31	32

**ELECTRICAL ACCESSORIES**

Disconnect	Standard Access - 0-7.5 kW	20W18	20W18	20W18	20W18	20W18
		15-22.5 kW	20W19	20W18	20W18	20W18
	Hinged Access - 0-7.5 kW	20W24	20W24	20W24	20W24	20W24
		15-22.5 kW	20W25	20W24	20W24	20W24

NOTE - All units have a minimum Short Circuit Current Rating (SCCR) of 5000 amps.

<sup>1</sup> Extremes of operating range are plus and minus 10% of line voltage.

<sup>2</sup> HACR type breaker or fuse.

<sup>3</sup> Refer to National or Canadian Electrical Code manual to determine wire, fuse and disconnect size requirements.



**ELECTRICAL/ELECTRIC HEAT DATA - KCB**
**6 TON**
**KCB072H HIGH EFFICIENCY - BELT DRIVE BLOWER**

<sup>1</sup> Voltage - 60hz		208/230V - 3 Ph		460V - 3 Ph		575V - 3 Ph	
Compressor	Rated Load Amps	19.6		8.2		6.6	
	Locked Rotor Amps	136		66.1		55.3	
Outdoor Fan Motor	Full Load Amps	2.4		1.3		1	
Power Exhaust (1) 0.33 HP	Full Load Amps	2.4		1.3		1	
Service Outlet 115V GFI (amps)		15		15		20	
Indoor Blower Motor	Horsepower	1	2	1	2	1	2
	Type	Belt	Belt	Belt	Belt	Belt	Belt
	Full Load Amps	4.6	7.5	2.1	3.4	1.7	2.7
<sup>2</sup> Maximum Overcurrent Protection	Unit Only	45	50	20	20	15	15
	with (1) 0.33 HP Power Exhaust	50	50	20	20	15	15
<sup>3</sup> Minimum Circuit Ampacity	Unit Only	30	32	13	14	10	11
	with (1) 0.33 HP Power Exhaust	32	35	14	15	11	12

**ELECTRIC HEAT DATA**

Electric Heat Voltage			208V	240V	208V	240V	480V	480V	600V	600V
<sup>2</sup> Maximum Overcurrent Protection	Unit + Electric Heat	7.5 kW	45	45	50	50	20	20	15	15
		15 kW	45	60	50	60	30	30	25	25
		22.5 kW	70	80	70	80	40	40	30	35
		30 kW	90	100	90	100	50	50	40	40
<sup>3</sup> Minimum Circuit Ampacity	Unit + Electric Heat	7.5 kW	30	30	32	32	14	16	12	13
		15 kW	45	51	49	55	26	27	21	22
		22.5 kW	65	74	69	78	37	39	30	31
		30 kW	84	96	88	100	48	50	39	40
<sup>2</sup> Maximum Overcurrent Protection	Unit + Electric Heat + Power Exhaust	7.5 kW	50	50	50	50	20	20	15	15
		15 kW	50	60	60	60	30	30	25	25
		22.5 kW	70	80	80	90	40	40	35	35
		30 kW	90	100	100	110	50	60	40	45
<sup>3</sup> Minimum Circuit Ampacity	Unit + Electric Heat + Power Exhaust	7.5 kW	32	32	35	35	16	18	13	14
		15 kW	48	54	52	58	27	29	22	23
		22.5 kW	68	77	72	81	39	40	31	32
		30 kW	87	99	91	103	50	51	40	41

**ELECTRICAL ACCESSORIES**

Disconnect	Standard Access - 0-22.5 kW	20W18	20W18	20W18	20W18
		30 kW	20W19	20W19	20W18
	Hinged Access - 0-22.5 kW	20W24	20W24	20W24	20W24
		30 kW	20W25	20W25	20W24

NOTE - All units have a minimum Short Circuit Current Rating (SCCR) of 5000 amps.

<sup>1</sup> Extremes of operating range are plus and minus 10% of line voltage.

<sup>2</sup> HACR type breaker or fuse.

<sup>3</sup> Refer to National or Canadian Electrical Code manual to determine wire, fuse and disconnect size requirements.

**ELECTRICAL/ELECTRIC HEAT DATA - KCB**

**6 TON**

**KCB074H HIGH EFFICIENCY - BELT DRIVE BLOWER**

<sup>1</sup> Voltage - 60hz		208/230V - 3 Ph		460V - 3 Ph		575V - 3 Ph	
Compressor	Rated Load Amps	17.6		8.5		6.3	
	Locked Rotor Amps	136		66.1		55.3	
Outdoor Fan Motor	Full Load Amps	2.4		1.3		1	
Power Exhaust (1) 0.33 HP	Full Load Amps	2.4		1.3		1	
Service Outlet 115V GFI (amps)		15		15		15	
Indoor Blower Motor	Horsepower	1	2	1	2	1	2
	Type	Belt	Belt	Belt	Belt	Belt	Belt
	Full Load Amps	4.6	7.5	2.1	3.4	1.7	2.7
<sup>2</sup> Maximum Overcurrent Protection	Unit Only	45	45	20	20	15	15
	with (1) 0.33 HP Power Exhaust	45	50	20	25	15	15
<sup>3</sup> Minimum Circuit Ampacity	Unit Only	29	32	15	16	11	12
	with (1) 0.33 HP Power Exhaust	32	35	16	17	12	13

**ELECTRIC HEAT DATA**

Electric Heat Voltage			208V	240V	208V	240V	480V	480V	600V	600V
<sup>2</sup> Maximum Overcurrent Protection	Unit + Electric Heat	7.5 kW	45	45	45	45	20	20	15	15
		15 kW	45	60	50	60	30	30	25	25
		22.5 kW	70	80	70	80	40	40	30	35
		30 kW	90	100	90	100	50	50	40	40
<sup>3</sup> Minimum Circuit Ampacity	Unit + Electric Heat	7.5 kW	29	29	32	32	15	16	12	13
		15 kW	45	51	49	55	26	27	21	22
		22.5 kW	65	74	69	78	37	39	30	31
		30 kW	84	96	88	100	48	50	39	40
<sup>2</sup> Maximum Overcurrent Protection	Unit + Electric Heat + Power Exhaust	7.5 kW	45	45	50	50	20	25	15	15
		15 kW	50	60	60	60	30	30	25	25
		22.5 kW	70	80	80	90	40	40	35	35
		30 kW	90	100	100	110	50	60	40	45
<sup>3</sup> Minimum Circuit Ampacity	Unit + Electric Heat + Power Exhaust	7.5 kW	32	32	35	35	16	18	13	14
		15 kW	48	54	52	58	27	29	22	23
		22.5 kW	68	77	72	81	39	40	31	32
		30 kW	87	99	91	103	50	51	40	41

**ELECTRICAL ACCESSORIES**

Disconnect	Standard Access - 0-22.5 kW	20W18	20W18	20W18	20W18
		30 kW	20W19	20W19	20W18
	Hinged Access - 0-22.5 kW	20W24	20W24	20W24	20W24
		30 kW	20W25	20W25	20W24

NOTE - All units have a minimum Short Circuit Current Rating (SCCR) of 5000 amps.

<sup>1</sup> Extremes of operating range are plus and minus 10% of line voltage.

<sup>2</sup> HACR type breaker or fuse.

<sup>3</sup> Refer to National or Canadian Electrical Code manual to determine wire, fuse and disconnect size requirements.

**ELECTRICAL/ELECTRIC HEAT DATA - KCB**
**6 TON**
**KCB074S STANDARD EFFICIENCY - BELT DRIVE BLOWER**

<sup>1</sup> Voltage - 60hz		208/230V - 3 Ph		460V - 3 Ph		575V - 3 Ph	
Compressor	Rated Load Amps	17.6		8.5		6.3	
	Locked Rotor Amps	136		66.1		55.3	
Outdoor Fan Motor	Full Load Amps	2.4		1.3		1	
Power Exhaust (1) 0.33 HP	Full Load Amps	2.4		1.3		1	
Service Outlet 115V GFI (amps)		15		15		20	
Indoor Blower Motor	Horsepower	1	2	1	2	1	2
	Type	Belt	Belt	Belt	Belt	Belt	Belt
	Full Load Amps	4.6	7.5	2.1	3.4	1.7	2.7
<sup>2</sup> Maximum Overcurrent Protection	Unit Only	45	45	20	20	15	15
	with (1) 0.33 HP Power Exhaust	45	50	20	25	15	15
<sup>3</sup> Minimum Circuit Ampacity	Unit Only	29	32	15	16	11	12
	with (1) 0.33 HP Power Exhaust	32	32	16	17	12	13

**ELECTRIC HEAT DATA**

Electric Heat Voltage			208V	240V	208V	240V	480V	480V	600V	600V
<sup>2</sup> Maximum Overcurrent Protection	Unit + Electric Heat	7.5 kW	45	45	45	45	20	20	15	15
		15 kW	45	60	50	60	30	30	25	25
		22.5 kW	70	80	70	80	40	40	30	35
		30 kW	90	100	90	100	50	50	40	40
<sup>3</sup> Minimum Circuit Ampacity	Unit + Electric Heat	7.5 kW	29	29	32	32	15	16	12	13
		15 kW	45	51	49	55	26	27	21	22
		22.5 kW	65	74	69	78	37	39	30	31
		30 kW	84	96	88	100	48	50	39	40
<sup>2</sup> Maximum Overcurrent Protection	Unit + Electric Heat + Power Exhaust	7.5 kW	45	45	50	50	20	25	15	15
		15 kW	50	60	60	60	30	30	25	25
		22.5 kW	70	80	80	90	40	40	35	35
		30 kW	90	100	100	110	50	60	40	45
<sup>3</sup> Minimum Circuit Ampacity	Unit + Electric Heat + Power Exhaust	7.5 kW	32	32	35	35	16	18	13	14
		15 kW	48	54	52	58	27	29	22	23
		22.5 kW	68	77	72	81	39	40	31	32
		30 kW	87	99	91	103	50	51	40	41

**ELECTRICAL ACCESSORIES**

Disconnect	Standard Access - 0-22.5 kW	20W18	20W18	20W18	20W18
		30 kW	20W19	20W19	20W18
	Hinged Access - 0-22.5 kW	20W24	20W24	20W24	20W24
		30 kW	20W25	20W25	20W24

NOTE - All units have a minimum Short Circuit Current Rating (SCCR) of 5000 amps.

<sup>1</sup> Extremes of operating range are plus and minus 10% of line voltage.

<sup>2</sup> HACR type breaker or fuse.

<sup>3</sup> Refer to National or Canadian Electrical Code manual to determine wire, fuse and disconnect size requirements.

**ELECTRICAL/ELECTRIC HEAT DATA - KCA**

**3 TON**

**KCA036S - DIRECT AND BELT DRIVE**

<sup>1</sup> Voltage - 60hz		208/230V - 3 Ph			460V - 3 Ph			575V - 3 Ph		
Compressor	Rated Load Amps	8.7			4			3.6		
	Locked Rotor Amps	70			31			27		
Outdoor Fan Motor	Full Load Amps	1.7			1.1			0.7		
Power Exhaust (1) 0.33 HP	Full Load Amps	2.4			1.3			1		
Service Outlet 115V GFI (amps)		15			15			20		
Indoor Blower Motor	Horsepower	0.5	1	2	0.5	1	2	0.5	1	2
	Type	Direct	Belt	Belt	Direct	Belt	Belt	Direct	Belt	Belt
	Full Load Amps	3.9	4.6	7.5	2	2.1	3.4	2	1.7	2.7
<sup>2</sup> Maximum Overcurrent Protection	Unit Only	25	25	25	15	15	15	15	15	15
	with (1) 0.33 HP Power Exhaust	25	25	30	15	15	15	15	15	15
<sup>3</sup> Minimum Circuit Ampacity	Unit Only	17	18	21	9	9	10	8	7	8
	with (1) 0.33 HP Power Exhaust	19	20	23	10	10	11	9	8	9

**ELECTRIC HEAT DATA**

Electric Heat Voltage			208V	240V	208V	240V	208V	240V	480V	480V	480V	600V	600V	600V
<sup>2</sup> Maximum Overcurrent Protection	Unit + Electric Heat	<b>7.5 kW</b>	25	30	30	30	30	35	15	15	20	15	15	15
		<b>15 kW</b>	45	50	45	60	50	60	30	30	30	25	25	25
<sup>3</sup> Minimum Circuit Ampacity	Unit + Electric Heat	<b>7.5 kW</b>	25	28	26	29	29	32	14	14	16	112	12	13
		<b>15 kW</b>	44	50	45	51	49	55	26	26	27	21	21	22
<sup>2</sup> Maximum Overcurrent Protection	Unit + Electric Heat + Power Exhaust	<b>7.5 kW</b>	30	35	30	35	35	35	20	20	20	15	15	15
		<b>15 kW</b>	50	60	50	60	60	60	30	30	30	25	25	25
<sup>3</sup> Minimum Circuit Ampacity	Unit + Electric Heat + Power Exhaust	<b>7.5 kW</b>	28	31	29	32	32	35	16	16	18	13	13	14
		<b>15 kW</b>	47	53	48	54	52	58	27	27	29	22	22	23

**ELECTRICAL ACCESSORIES**

Disconnect	Standard Access - 0-7.5 kW	20W15	20W15	20W15	20W15	20W15
		20W15	20W15	20W15	20W15	20W15
	Hinged Access - 0-7.5 kW	20W21	20W21	20W21	20W21	20W21
		20W21	20W21	20W21	20W21	20W21

NOTE - All units have a minimum Short Circuit Current Rating (SCCR) of 5000 amps.

<sup>1</sup> Extremes of operating range are plus and minus 10% of line voltage.

<sup>2</sup> HACR type breaker or fuse.

<sup>3</sup> Refer to National or Canadian Electrical Code manual to determine wire, fuse and disconnect size requirements.

**ELECTRICAL/ELECTRIC HEAT DATA - KCA**

**4 TON**

**KCA048S - DIRECT AND BELT DRIVE**

<sup>1</sup> Voltage - 60hz		208/230V - 3 Ph			460V - 3 Ph			575V - 3 Ph		
Compressor	Rated Load Amps	11			5.5			4.7		
	Locked Rotor Amps	86			37			34		
Outdoor Fan Motor	Full Load Amps	1.7			1.1			0.7		
Power Exhaust (1) 0.33 HP	Full Load Amps	2.4			1.3			1		
Service Outlet 115V GFI (amps)		15			15			20		
Indoor Blower Motor	Horsepower	0.5	1	2	0.5	1	2	0.5	1	2
	Type	Direct	Belt	Belt	Direct	Belt	Belt	Direct	Belt	Belt
	Full Load Amps	3.9	4.6	7.5	2	2.1	3.4	2	1.7	2.7
<sup>2</sup> Maximum Overcurrent Protection	Unit Only	30	30	30	15	15	15	15	15	15
	with (1) 0.33 HP Power Exhaust	30	30	35	15	15	15	15	15	15
<sup>3</sup> Minimum Circuit Ampacity	Unit Only	20	21	23	10	11	13	12	9	10
	with (1) 0.33 HP Power Exhaust	22	23	26	12	12	13	10	10	11

**ELECTRIC HEAT DATA**

Electric Heat Voltage			208V	240V	208V	240V	208V	240V	480V	480V	480V	600V	600V	600V
<sup>2</sup> Maximum Overcurrent Protection	Unit + Electric Heat	<b>7.5 kW</b>	30	30	30	30	30	35	15	15	20	15	15	15
		<b>15 kW</b>	45	50	45	60	50	60	30	30	30	25	25	25
<sup>3</sup> Minimum Circuit Ampacity	Unit + Electric Heat	<b>7.5 kW</b>	25	28	26	29	29	32	14	14	16	12	12	13
		<b>15 kW</b>	44	50	45	51	49	55	26	26	27	21	21	22
<sup>2</sup> Maximum Overcurrent Protection	Unit + Electric Heat + Power Exhaust	<b>7.5 kW</b>	30	35	30	35	35	35	20	20	20	15	15	15
		<b>15 kW</b>	50	60	50	60	60	60	30	30	30	25	25	25
<sup>3</sup> Minimum Circuit Ampacity	Unit + Electric Heat + Power Exhaust	<b>7.5 kW</b>	28	31	29	32	32	35	16	16	18	13	13	14
		<b>15 kW</b>	47	53	48	54	52	58	27	27	29	22	22	23

**ELECTRICAL ACCESSORIES**

<b>Disconnect</b>	Standard Access - <b>0-7.5 kW</b>	<b>20W15</b>	<b>20W15</b>	<b>20W15</b>	<b>20W15</b>	<b>20W15</b>
	<b>15 kW</b>	<b>20W15</b>	<b>20W15</b>	<b>20W15</b>	<b>20W15</b>	<b>20W15</b>
	Hinged Access - <b>0-7.5 kW</b>	<b>20W21</b>	<b>20W21</b>	<b>20W21</b>	<b>20W21</b>	<b>20W21</b>
	<b>15 kW</b>	<b>20W21</b>	<b>20W21</b>	<b>20W21</b>	<b>20W21</b>	<b>20W21</b>

NOTE - All units have a minimum Short Circuit Current Rating (SCCR) of 5000 amps.

<sup>1</sup> Extremes of operating range are plus and minus 10% of line voltage.

<sup>2</sup> HACR type breaker or fuse.

<sup>3</sup> Refer to National or Canadian Electrical Code manual to determine wire, fuse and disconnect size requirements.

**ELECTRICAL/ELECTRIC HEAT DATA - KCA**

**5 TON**

**KCA060S - DIRECT AND BELT DRIVE**

<sup>1</sup> Voltage - 60hz		208/230V - 3 Ph			460V - 3 Ph			575V - 3 Ph		
Compressor	Rated Load Amps	13.5			8			5		
	Locked Rotor Amps	109			59			40		
Outdoor Fan Motor	Full Load Amps	2.4			1.3			1		
Power Exhaust (1) 0.33 HP	Full Load Amps	2.4			1.3			1		
Service Outlet 115V GFI (amps)		15			15			20		
Indoor Blower Motor	Horsepower Type	0.75	1	2	0.75	1	2	0.75	1	2
		Direct	Belt	Belt	Direct	Belt	Belt	Direct	Belt	Belt
	Full Load Amps	4.9	4.6	7.5	2.5	2.1	3.4	2.5	1.7	2.7
<sup>2</sup> Maximum Overcurrent Protection	Unit Only	35	35	40	20	20	20	15	15	15
	with (1) 0.33 HP Power Exhaust	40	35	40	20	20	20	15	15	15
<sup>3</sup> Minimum Circuit Ampacity	Unit Only	25	24	27	14	14	15	10	9	10
	with (1) 0.33 HP Power Exhaust	27	27	30	16	15	16	11	10	11

**ELECTRIC HEAT DATA**

Electric Heat Voltage			208V	240V	208V	240V	208V	240V	480V	480V	480V	600V	600V	600V
<sup>2</sup> Maximum Overcurrent Protection	Unit + Electric Heat	7.5 kW	35	35	35	35	40	40	20	20	20	15	15	15
		15 kW	50	60	45	60	50	60	30	30	30	25	25	25
		22.5 kW	70	80	70	80	70	80	40	40	40	35	30	35
<sup>3</sup> Minimum Circuit Ampacity	Unit + Electric Heat	7.5 kW	26	29	26	29	29	32	15	14	16	13	12	13
		15 kW	46	52	45	51	49	55	26	26	27	22	21	22
		22.5 kW	65	74	65	74	69	78	37	37	39	31	30	31
<sup>2</sup> Maximum Overcurrent Protection	Unit + Electric Heat + Power Exhaust	7.5 kW	40	40	35	35	40	40	20	20	20	15	15	15
		15 kW	50	60	50	60	60	60	30	30	30	25	25	25
		22.5 kW	70	80	70	80	80	90	40	40	40	35	35	35
<sup>3</sup> Minimum Circuit Ampacity	Unit + Electric Heat + Power Exhaust	7.5 kW	29	32	29	32	32	35	17	16	18	14	13	14
		15 kW	49	55	48	54	52	58	28	27	29	23	22	23
		22.5 kW	68	77	68	77	72	81	39	39	40	32	31	32

**ELECTRICAL ACCESSORIES**

Disconnect	Standard Access - 0-22.5 kW	20W15	20W15	20W15	20W15	20W15
	Hinged Access - 0-22.5 kW	20W21	20W21	20W21	20W21	20W21

NOTE - All units have a minimum Short Circuit Current Rating (SCCR) of 5000 amps.

<sup>1</sup> Extremes of operating range are plus and minus 10% of line voltage.

<sup>2</sup> HACR type breaker or fuse.

<sup>3</sup> Refer to National or Canadian Electrical Code manual to determine wire, fuse and disconnect size requirements.

**ELECTRICAL/ELECTRIC HEAT DATA - KCA**

**6 TON**

**KCA072S - BELT DRIVE BLOWER**

<sup>1</sup> Voltage - 60hz		208/230V - 3 Ph		460V - 3 Ph		575V - 3 Ph	
Compressor	Rated Load Amps	19.6		8.2		6.6	
	Locked Rotor Amps	136		66.1		55.3	
Outdoor Fan Motor	Full Load Amps	2.4		1.3		1	
Power Exhaust (1) 0.33 HP	Full Load Amps	2.4		1.3		1	
Service Outlet 115V GFI (amps)		15		15		20	
Indoor Blower Motor	Horsepower	1	2	1	2	1	2
	Type	Belt	Belt	Belt	Belt	Belt	Belt
	Full Load Amps	4.6	7.5	2.1	3.4	1.7	2.7
<sup>2</sup> Maximum Overcurrent Protection	Unit Only	50	50	20	20	15	15
	with (1) 0.33 HP Power Exhaust	50	50	20	20	15	15
<sup>3</sup> Minimum Circuit Ampacity	Unit Only	32	35	14	15	11	12
	with (1) 0.33 HP Power Exhaust	34	37	15	17	12	13

**ELECTRIC HEAT DATA**

Electric Heat Voltage			208V	240V	208V	240V	480V	480V	600V	600V
<sup>2</sup> Maximum Overcurrent Protection	Unit + Electric Heat	7.5 kW	50	50	50	50	20	20	15	15
		15 kW	50	60	50	60	30	30	25	25
		22.5 kW	70	80	70	80	40	40	30	35
		30 kW	90	100	90	100	50	50	40	40
<sup>3</sup> Minimum Circuit Ampacity	Unit + Electric Heat	7.5 kW	32	32	35	35	14	16	12	13
		15 kW	45	51	49	55	26	27	21	22
		22.5 kW	65	74	69	78	37	39	30	31
		30 kW	84	96	88	100	48	50	39	40
<sup>2</sup> Maximum Overcurrent Protection	Unit + Electric Heat + Power Exhaust	7.5 kW	50	50	50	50	20	20	15	15
		15 kW	50	60	60	60	30	30	25	25
		22.5 kW	70	80	80	90	40	40	35	35
		30 kW	90	100	100	110	50	60	40	45
<sup>3</sup> Minimum Circuit Ampacity	Unit + Electric Heat + Power Exhaust	7.5 kW	34	34	37	37	16	18	13	14
		15 kW	48	54	52	58	27	29	22	23
		22.5 kW	68	77	72	81	39	40	31	32
		30 kW	87	99	91	103	50	51	40	41

**ELECTRICAL ACCESSORIES**

Disconnect	Standard Access - 0-22.5 kW	20W18	20W18	20W18	20W18
		30 kW	20W19	20W19	20W18
	Hinged Access - 0-22.5 kW	20W24	20W24	20W24	20W24
		30 kW	20W25	20W25	20W24

NOTE - All units have a minimum Short Circuit Current Rating (SCCR) of 5000 amps.

<sup>1</sup> Extremes of operating range are plus and minus 10% of line voltage.

<sup>2</sup> HACR type breaker or fuse.

<sup>3</sup> Refer to National or Canadian Electrical Code manual to determine wire, fuse and disconnect size requirements.

**ELECTRICAL/ELECTRIC HEAT DATA - KCA**

**7.5 TON**

**KCA090S - BELT DRIVE BLOWER**

<sup>1</sup> Voltage - 60hz		208/230V - 3 Ph			460V - 3 Ph			575V - 3 Ph		
Compressor	Rated Load Amps	25			12.2			9		
	Locked Rotor Amps	164			100			78		
Outdoor Fan Motor	Full Load Amps	2.4			1.3			1		
Power Exhaust (1) 0.33 HP	Full Load Amps	2.4			1.3			1		
Service Outlet 115V GFI (amps)		15			15			20		
Indoor Blower Motor	Horsepower	1	2	3	1	2	3	1	2	3
	Type	Belt	Belt	Belt	Belt	Belt	Belt	Belt	Belt	Belt
	Full Load Amps	4.6	7.5	10.6	2.1	3.4	4.8	1.7	2.7	3.9
<sup>2</sup> Maximum Overcurrent Protection	Unit Only	60	60	60	30	30	30	20	20	25
	with (1) 0.33 HP Power Exhaust	60	60	70	30	30	30	20	20	25
<sup>3</sup> Minimum Circuit Ampacity	Unit Only	39	42	45	19	20	22	14	15	17
	with (1) 0.33 HP Power Exhaust	41	44	47	20	22	23	15	16	18

**ELECTRIC HEAT DATA**

Electric Heat Voltage			208V	240V	208V	240V	208V	240V	480V	480V	480V	600V	600V	600V
<sup>2</sup> Maximum Overcurrent Protection	Unit + Electric Heat	7.5 kW	60	60	60	60	60	60	30	30	30	20	20	25
		15 kW	60	60	60	60	60	60	30	30	30	25	25	25
		22.5 kW	70	80	70	80	80	90	40	40	40	30	35	35
		30 kW	90	100	90	100	100	110	50	50	60	40	40	45
<sup>3</sup> Minimum Circuit Ampacity	Unit + Electric Heat	7.5 kW	39	39	42	42	45	45	19	20	22	14	15	17
		15 kW	45	51	49	55	53	59	26	27	29	21	22	23
		22.5 kW	65	74	69	78	72	81	37	39	40	30	31	32
		30 kW	84	96	88	100	92	104	48	50	52	39	40	41
<sup>2</sup> Maximum Overcurrent Protection	Unit + Electric Heat + Power Exhaust	7.5 kW	60	60	60	60	70	70	30	30	30	20	20	25
		15 kW	60	60	60	60	70	70	30	30	35	25	25	25
		22.5 kW	70	80	80	90	80	90	40	40	45	35	35	35
		30 kW	90	100	100	110	100	110	50	60	60	40	45	45
<sup>3</sup> Minimum Circuit Ampacity	Unit + Electric Heat + Power Exhaust	7.5 kW	41	41	44	44	47	47	20	22	23	15	16	18
		15 kW	48	54	52	58	56	62	27	29	31	22	23	25
		22.5 kW	68	77	72	81	75	84	39	40	42	31	32	34
		30 kW	87	99	91	103	95	107	50	51	53	40	41	43

**ELECTRICAL ACCESSORIES**

Disconnect	Standard Access - 0-22.5 kW	20W18	20W18	20W18	20W18	20W18
		30 kW	20W19	20W19	20W19	20W18
	Hinged Access - 0-22.5 kW	20W24	20W24	20W24	20W24	20W24
		30 kW	20W25	20W25	20W25	20W24

NOTE - All units have a minimum Short Circuit Current Rating (SCCR) of 5000 amps.

<sup>1</sup> Extremes of operating range are plus and minus 10% of line voltage.

<sup>2</sup> HACR type breaker or fuse.

<sup>3</sup> Refer to National or Canadian Electrical Code manual to determine wire, fuse and disconnect size requirements.



## ELECTRIC HEAT CAPACITIES

Input Voltage	5 kW			7.5 kW			10 kW		
	No of Stages	kW input	Btuh Output	No of Stages	kW input	Btuh Output	No of Stages	kW input	Btuh Output
208	1	3.8	12,800	1	5.6	19,200	1	7.5	25,600
220	1	4.2	14,300	1	6.3	21,500	1	8.4	28,700
230	1	4.6	15,700	1	6.9	23,500	1	9.2	31,400
240	1	5.0	17,100	1	7.5	25,600	1	10.0	34,200
440	---	---	---	1	6.3	21,500	---	---	---
460	---	---	---	1	6.9	23,500	---	---	---
480	---	---	---	1	7.5	25,600	---	---	---
550	---	---	---	1	6.3	21,500	---	---	---
575	---	---	---	1	6.9	23,500	---	---	---
600	---	---	---	1	7.5	25,600	---	---	---

Input Voltage	15 kW			22.5 kW			30 kW		
	No of Stages	kW input	Btuh Output	No of Stages	kW input	Btuh Output	No of Stages	kW input	Btuh Output
208	1	11.2	38,400	1	16.9	57,700	1	22.5	76,800
220	1	12.6	43,000	1	18.9	64,500	1	25.2	86,000
230	1	13.8	47,000	1	20.7	70,700	1	27.5	93,900
240	1	15.0	51,200	1	22.5	76,800	1	30.0	102,400
440	1	12.6	43,000	1	18.9	64,500	1	25.2	86,000
460	1	13.8	47,000	1	20.7	70,700	1	27.5	93,900
480	1	15.0	51,200	1	22.5	76,800	1	30.0	102,400
550	1	12.6	43,000	1	18.9	64,500	1	25.2	86,000
575	1	13.8	47,000	1	20.7	70,700	1	27.5	93,900
600	1	15.0	51,200	1	22.5	76,800	1	30.0	102,400

## UNIT CLEARANCES - INCHES (MM)

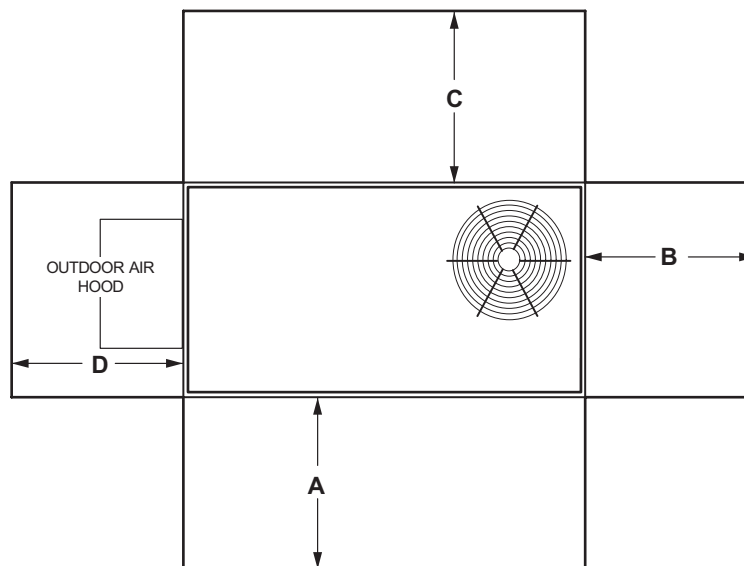

<sup>1</sup> Unit Clearance	A		B		C		D		Top Clearance
	in.	mm	in.	mm	in.	mm	in.	mm	
Service Clearance	36	914	36	914	36	914	36	914	Unobstructed
Minimum Operation Clearance	36	914	36	914	36	914	36	914	

NOTE - Entire perimeter of unit base requires support when elevated above the mounting surface.

<sup>1</sup> Service Clearance - Required for removal of serviceable parts.

Minimum Operation Clearance - Required clearance for proper unit operation.

## OPTIONAL CONVENTIONAL TEMPERATURE CONTROL SYSTEMS

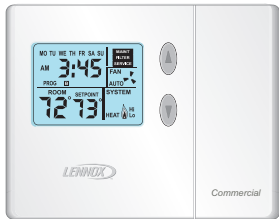
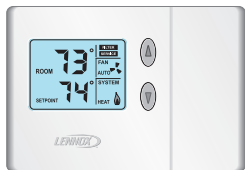
Item	Model No.	Catalog No.
<p><b>COMFORTSENSE® 7500 COMMERCIAL 7-DAY PROGRAMMABLE THERMOSTAT</b></p>  <ul style="list-style-type: none"> <li>• Four-Stage Heating / Two-Stage Cooling Universal Multi-Stage</li> <li>• Intuitive Touchscreen Interface</li> <li>• Remote Indoor Temperature Sensing with Averaging</li> <li>• Outside or Discharge Air Temperature Display</li> <li>• Full Seven-Day Programming</li> <li>• Four Time Periods Per Day</li> <li>• Occupancy Scheduling with Economizer Relay Control</li> <li>• Away Mode</li> <li>• Holiday Scheduling</li> <li>• Smooth Setback Recovery (SSR)</li> <li>• Performance Reports</li> <li>• Notifications/Reminders</li> <li>• Dehumidification/Humiditrol® Control for Split Systems and Rooftop Units</li> <li>• Economizer Relay Control</li> <li>• Backlit Display</li> <li>• Wallplate Furnished</li> </ul>	C0STAT06FF1L	<b>13H15</b>
<p><b>Optional Accessories</b></p> <p><sup>1</sup> Remote non-adjustable wall mount 20k temperature sensor C0SNZN01AE2- <b>47W36</b></p> <p><sup>1</sup> Remote non-adjustable wall mount 10k temperature sensor C0SNZN73AE1- <b>47W37</b></p> <p>Remote non-adjustable discharge air (duct mount) temperature sensor C0SNDC00AE1- <b>19L22</b></p> <p>Outdoor temperature sensor C0SNSR03AE1- <b>X2658</b></p> <p>Locking cover (clear) C0MISC15AE1- <b>39P21</b></p> <p><sup>1</sup> Remote sensors can be applied in any of the following combinations:            One Sensor - (1) 47W36            Two Sensors - (2) 47W37            Three Sensors - (2) 47W36 and (1) 47W37            Four Sensors - (4) 47W36            Five Sensors - (3) 47W36 and (2) 47W37</p>		
<p><b>COMFORTSENSE® 3000 COMMERCIAL 5-2 DAY PROGRAMMABLE THERMOSTAT</b></p>  <ul style="list-style-type: none"> <li>• Two-Stage Heating / Two-Stage Cooling Conventional Systems</li> <li>• Intuitive Interface</li> <li>• 5-2 Day Programming</li> <li>• Program Hold</li> <li>• Remote Indoor Temperature Sensing</li> <li>• Smooth Setback Recovery (SSR)</li> <li>• Economizer Relay Control</li> <li>• Maintenance/Filter/Service Reminders</li> <li>• Backlit Display</li> <li>• Wallplate Furnished</li> <li>• Simple Up and Down Temperature Control.</li> </ul>	C0STAT05FF1L	<b>11Y05</b>
<p><b>Optional Accessories</b></p> <p>Remote non-adjustable wall mount 10k averaging temperature sensor C0SNZN73AE1- <b>47W37</b></p> <p>Optional wall mounting plate C0MISC17AE1- <b>X2659</b></p>		
<p><b>DIGITAL NON-PROGRAMMABLE THERMOSTAT</b></p>  <ul style="list-style-type: none"> <li>• One-Stage Heating / Cooling Conventional Systems</li> <li>• Intuitive Interface</li> <li>• Automatic Changeover</li> <li>• Backlit Display</li> <li>• Simple Up and Down Temperature Control.</li> </ul>	C0STAT12AE1L	<b>51M32</b>
<p><b>Optional Accessories</b></p> <p>Outdoor temperature sensor C0SNSR04AE1- <b>X2658</b></p> <p>Optional wall mounting plate C0MISC17AE1- <b>X2659</b></p>		

## WEIGHT DATA

Model Number	Net				Shipping			
	Base		Max.		Base		Max.	
	lbs.	kg	lbs.	kg	lbs.	kg	lbs.	kg
KCB024S	502	228	606	275	543	264	647	293
KCB030S	505	229	609	276	546	248	650	295
KCA036S	498	226	610	277	558	253	679	308
KCB036S	527	239	653	296	568	258	694	315
KCA048S	535	243	647	293	595	270	716	325
KCB048S	527	239	654	297	568	258	695	315
KCA060S	565	256	681	309	625	283	750	340
KCB060S	620	281	750	340	661	300	791	359
KCA072S, 072H, 074S, 074H	620	281	721	327	661	300	762	346
KCA090S	745	334	851	386	805	365	920	417

Base Unit - The unit with NO OPTIONS.

Max. Unit - The unit with ALL OPTIONS installed (Economizer, etc.).

## OPTIONS / ACCESSORIES

	Shipping Weights		
	lbs.	kg	
<b>ECONOMIZER / OUTDOOR AIR / POWER EXHAUST</b>			
<b>Economizer</b>			
Economizer - Includes Barometric Relief Dampers and Exhaust Hood	131	59	
<b>Outdoor Air Dampers</b>			
Motorized	25	12	
Manual	18	9	
<b>Power Exhaust</b>			
Standard Static	35	16	
<b>ELECTRIC HEAT</b>			
5 kW	31	14	
7.5 kW	31	14	
10 kW	31	14	
15 kW	31	14	
22.5 kW	35	16	
30 kW	35	16	
<b>ROOF CURBS</b>			
<b>Hybrid Roof Curbs, Downflow</b>			
8 in. height	50	23	
14 in. height	70	32	
18 in. height	80	36	
24 in. height	100	45	
<b>Hybrid Curbs, Full Perimeter, Downflow</b>			
8 in. height	57	26	
14 in. height	60	27	
18 in. height	91	41	
24 in. height	114	52	
<b>Adjustable Pitch Curb, Downflow</b>			
14 in. height	113	51	
<b>CEILING DIFFUSERS</b>			
Step-Down	RTD9-65S	80	36
	RTD11-95S	118	54
Flush	FD9-65S	80	36
	FD11-95S	118	54
Transitions (Supply and Return)	T1TRAN10AN1	22	10
	T1TRAN20N-1	21	10

## DIMENSIONS - UNIT - INCHES (MM) - KCA

Model No.	CORNER WEIGHTS										CENTER OF GRAVITY													
	AA		BB		CC		DD		EE		FF		FF		FF									
	Base	Max.	Base	Max.	Base	Max.	Base	Max.	Base	Max.	Base	Max.	Base	Max.	Base	Max.								
	lbs.	kg	lbs.	kg	lbs.	kg	lbs.	kg	lbs.	kg	in.	mm	in.	mm	in.	mm	in.	mm						
<b>036</b>	86	39	110	50	105	48	124	56	169	77	200	91	139	63	177	80	38-1/2	978	40	1016	18	457	18	457
<b>048</b>	93	42	116	53	112	51	132	60	181	82	212	96	149	68	187	85	38-1/2	978	40	1016	18	457	18	457
<b>060</b>	98	44	122	56	119	54	138	63	191	87	223	101	157	72	197	90	38-1/2	978	40	1016	18	457	18	457
<b>072</b>	118	53	142	65	140	63	152	69	197	89	205	93	166	75	251	114	39	991	44-3/4	1137	19-1/2	495	20	508
<b>090</b>	164	74	187	85	179	81	203	92	221	100	252	114	203	92	231	105	47	1194	47	1194	21	533	21	533

Base Unit - The unit with NO INTERNAL OPTIONS.

Max. Unit - The unit with ALL INTERNAL OPTIONS Installed. (Economizer, Standard Static Power Exhaust Fans, Controls, etc.). Does not include accessories external to unit or high static power exhaust.

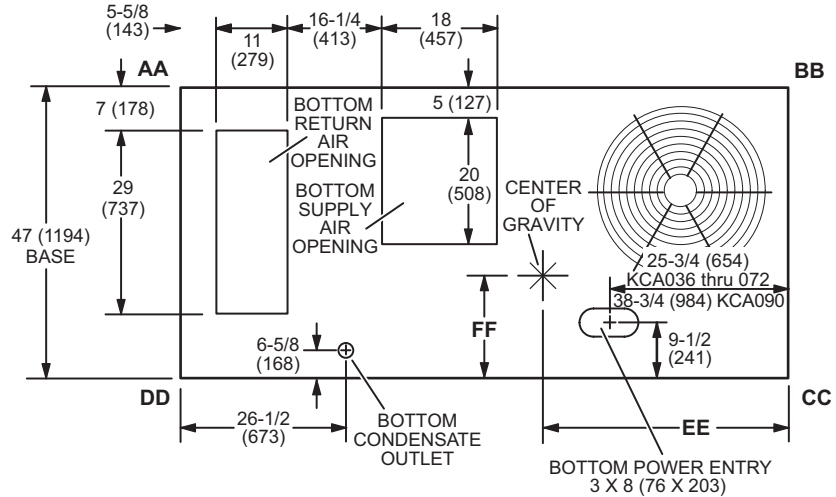

**TOP VIEW (Base)**

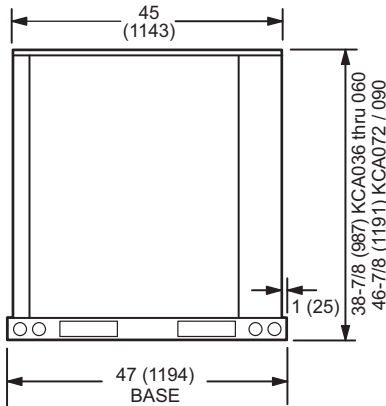

**END VIEW**

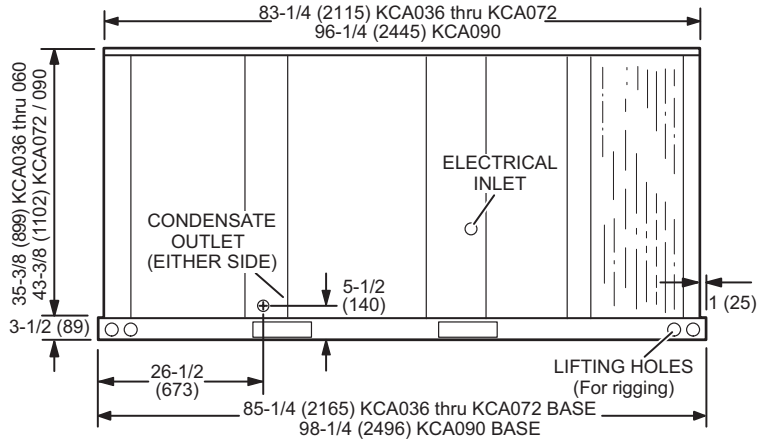

**SIDE VIEW**

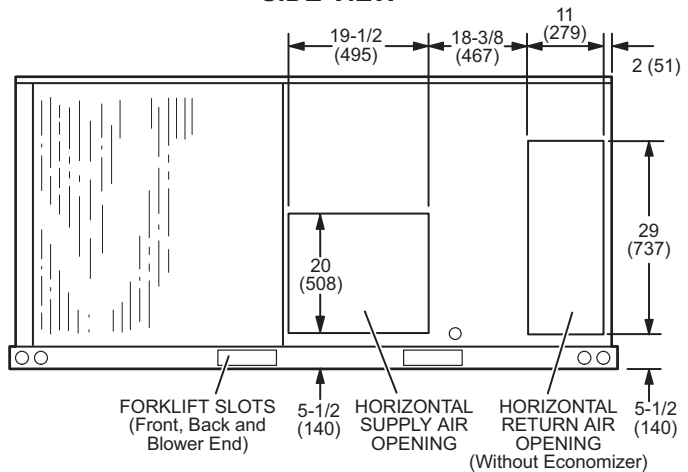

**BACK VIEW**

# DIMENSIONS - UNIT - INCHES (MM) - KCB

Model No.	CORNER WEIGHTS								CENTER OF GRAVITY							
	AA		BB		CC		DD		EE		FF		FF			
	Base lbs. kg	Max. lbs. kg	Base lbs. kg	Max. lbs. kg	Base lbs. kg	Max. lbs. kg	Base lbs. kg	Max. lbs. kg	Base in. mm	Max. in. mm	Base in. mm	Max. in. mm	Base in. mm	Max. in. mm		
024	101 46	122 56	118 53	125 57	152 69	161 73	131 60	197 90	39-1/2 1003	45 1143	20-1/2 521	20-1/2 521				
030	102 46	123 56	118 54	125 57	153 69	162 74	132 60	197 90	39-1/2 1003	45 1143	20-1/2 521	20-1/2 521				
036	107 48	132 60	123 56	131 60	159 72	177 80	138 62	213 97	39-1/2 1003	45 1143	20-1/2 521	20 508				
048	107 48	132 60	123 56	131 60	159 72	177 81	138 62	213 97	39-1/2 1003	45 1143	20-1/2 521	20 508				
060	118 53	142 65	140 63	152 69	197 89	205 93	166 75	251 114	39 991	44-3/4 1137	19-1/2 495	20 508				
072	118 53	142 65	140 63	152 69	197 89	205 93	166 75	251 114	39 991	44-3/4 1137	19-1/2 495	20 508				
074	118 53	142 65	140 63	152 69	197 89	205 93	166 75	251 114	39 991	44-3/4 1137	19-1/2 495	20 508				

Base Unit - The unit with NO INTERNAL OPTIONS.

Max. Unit - The unit with ALL INTERNAL OPTIONS Installed. (Economizer, Standard Static Power Exhaust Fans, Controls, etc.). Does not include accessories external to unit or high static power exhaust.

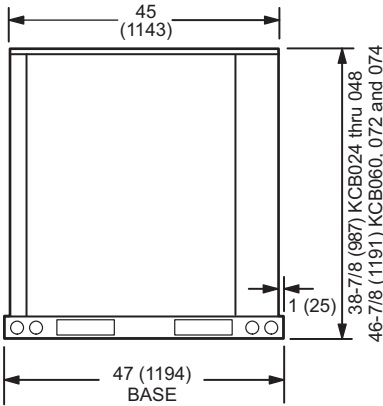
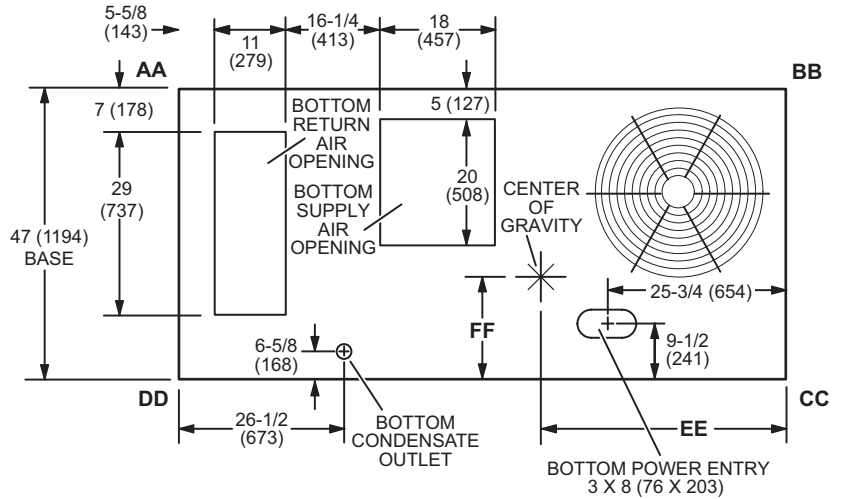

**END VIEW**

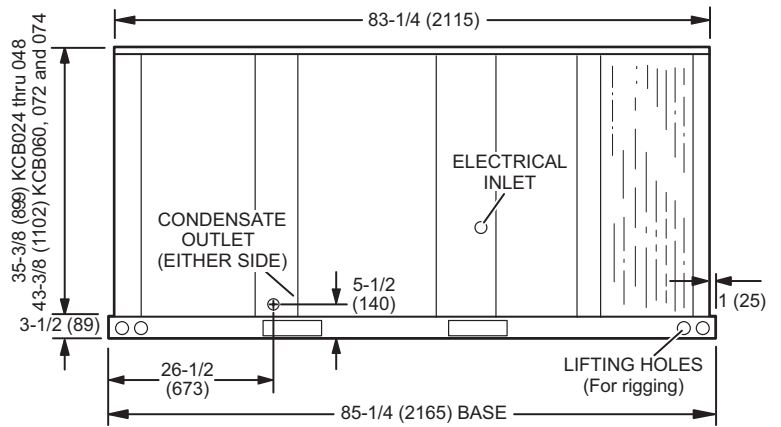

**SIDE VIEW**

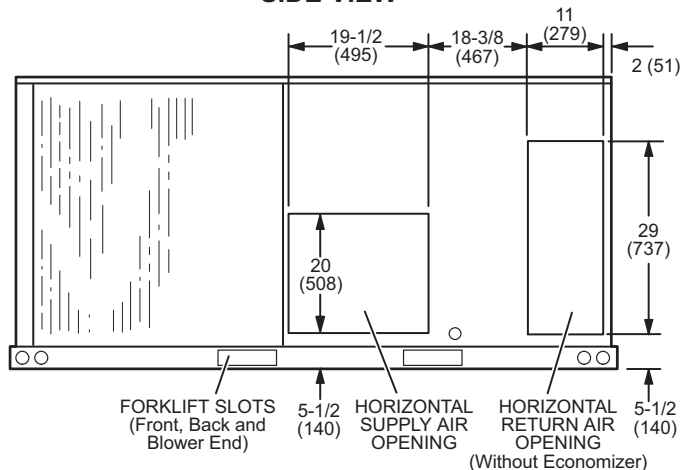

**BACK VIEW**

**DIMENSIONS - ACCESSORIES - INCHES (MM)**

**OUTDOOR AIR HOOD DETAIL FOR OPTIONAL ECONOMIZER AND BAROMETRIC RELIEF DAMPERS  
(Downflow Applications)**

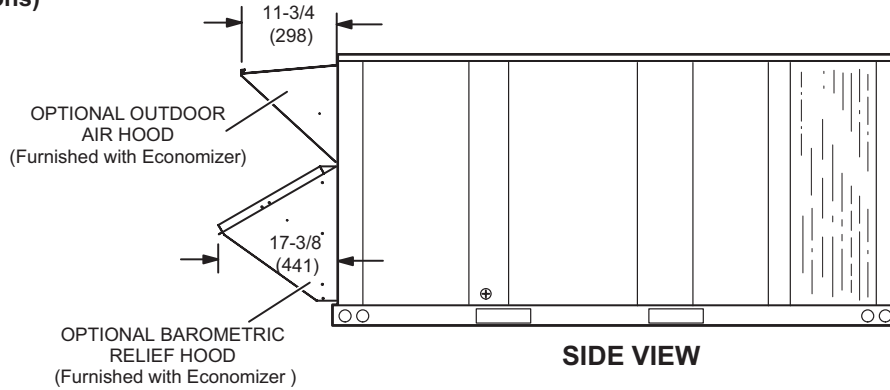

**OUTDOOR AIR HOOD FOR ECONOMIZER  
(Furnished)**

**BAROMETRIC RELIEF HOOD FOR ECONOMIZER  
(Furnished)**

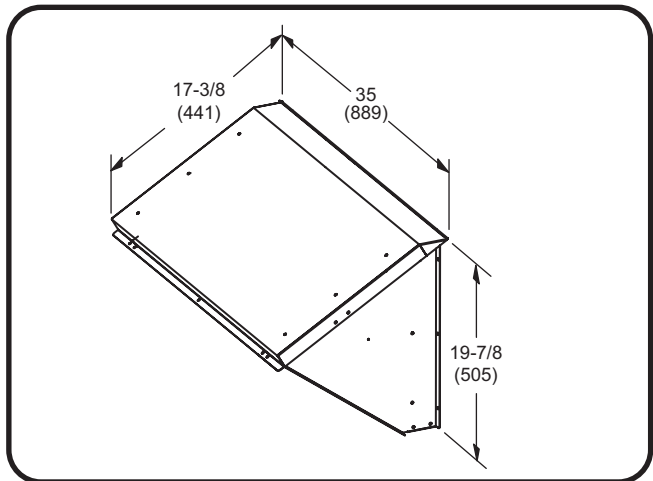
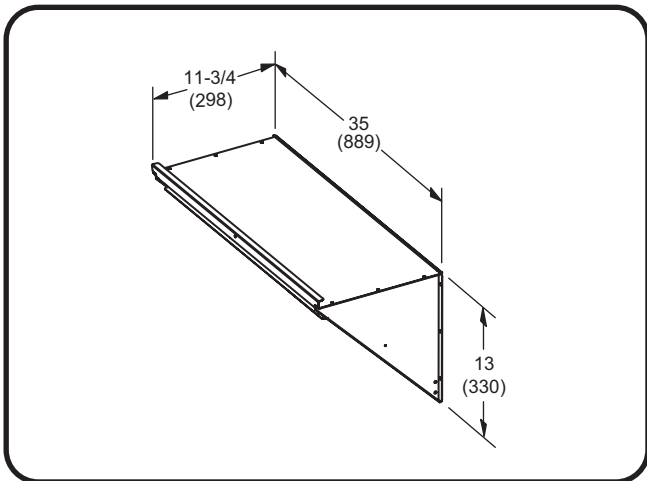

**OUTDOOR AIR DAMPER HOOD DETAIL FOR OPTIONAL MANUAL OR MOTORIZED OUTDOOR AIR DAMPERS  
(Downflow or Horizontal Applications)**

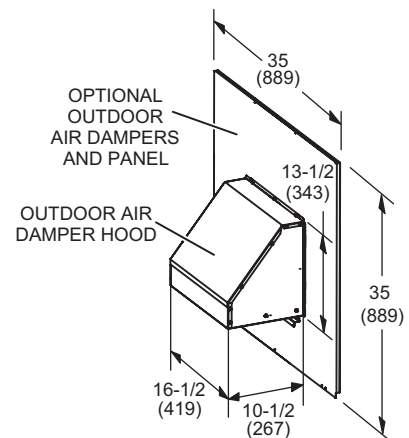
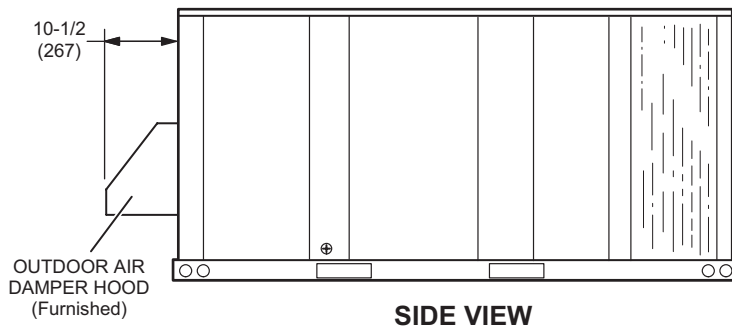

## DIMENSIONS - ACCESSORIES - INCHES (MM)

### OUTDOOR AIR HOOD DETAIL WITH OPTIONAL ECONOMIZER AND BAROMETRIC RELIEF DAMPERS (Horizontal Applications)

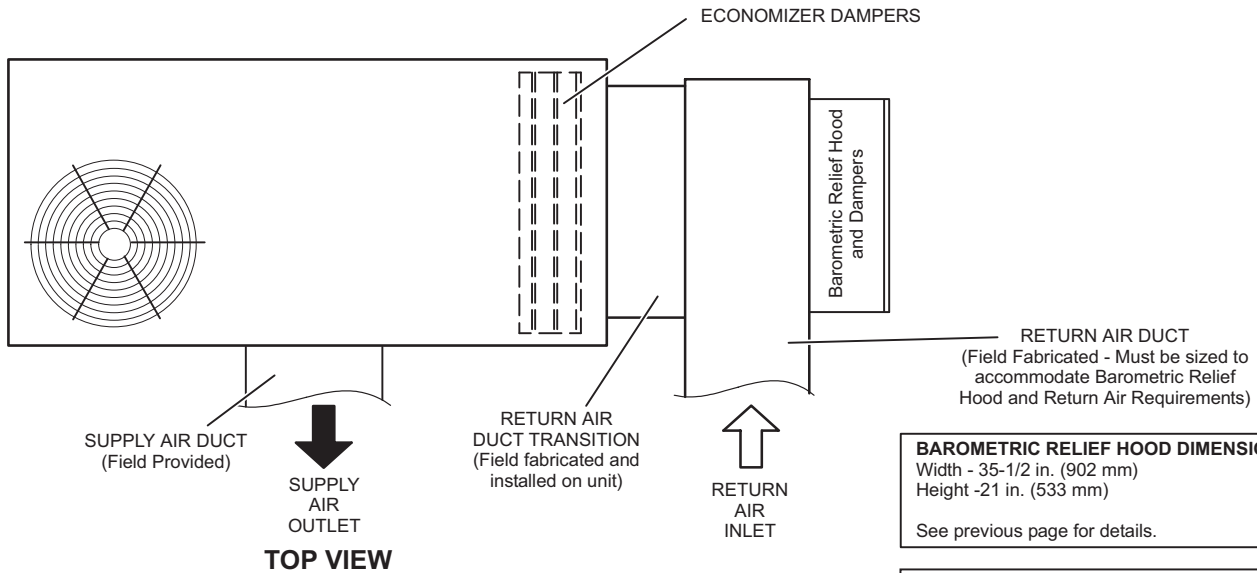

**NOTE - Horizontal applications with Economizer require Horizontal Economizer Conversion Kit.**  
See Options/Accessories table.

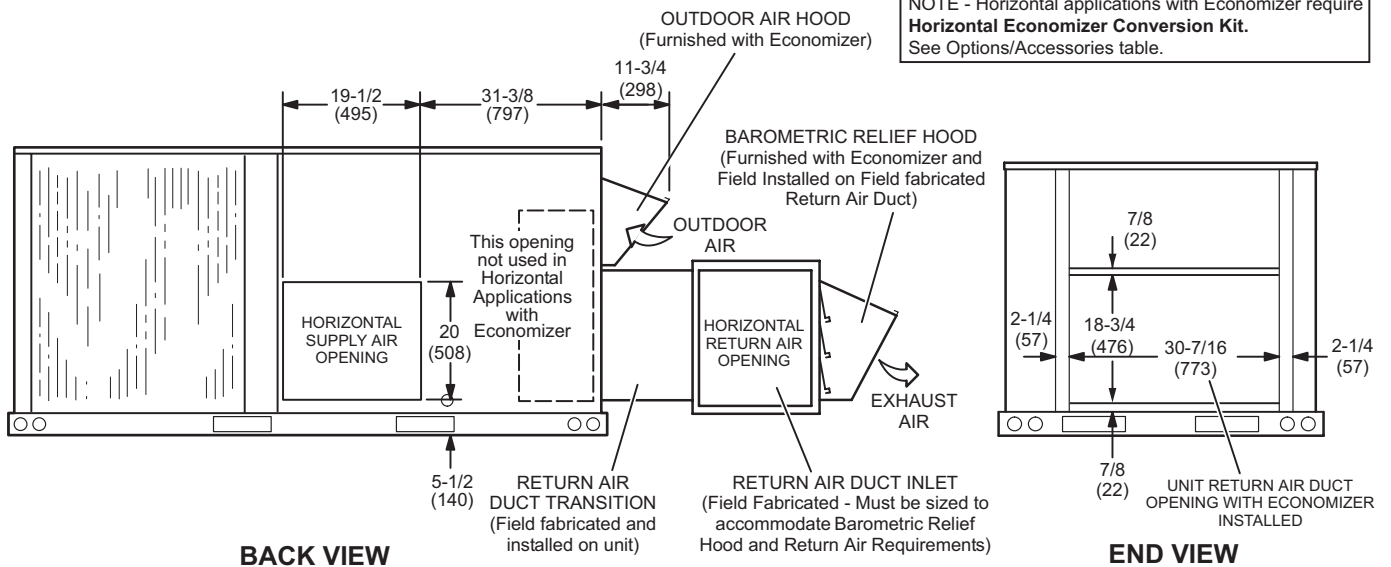

**NOTE - Return Air Duct and Transition must be supported.**

# DIMENSIONS - ACCESSORIES - INCHES (MM)

## HYBRID ROOF CURBS - DOUBLE DUCT OPENING - STANDARD AND FULL PERIMETER

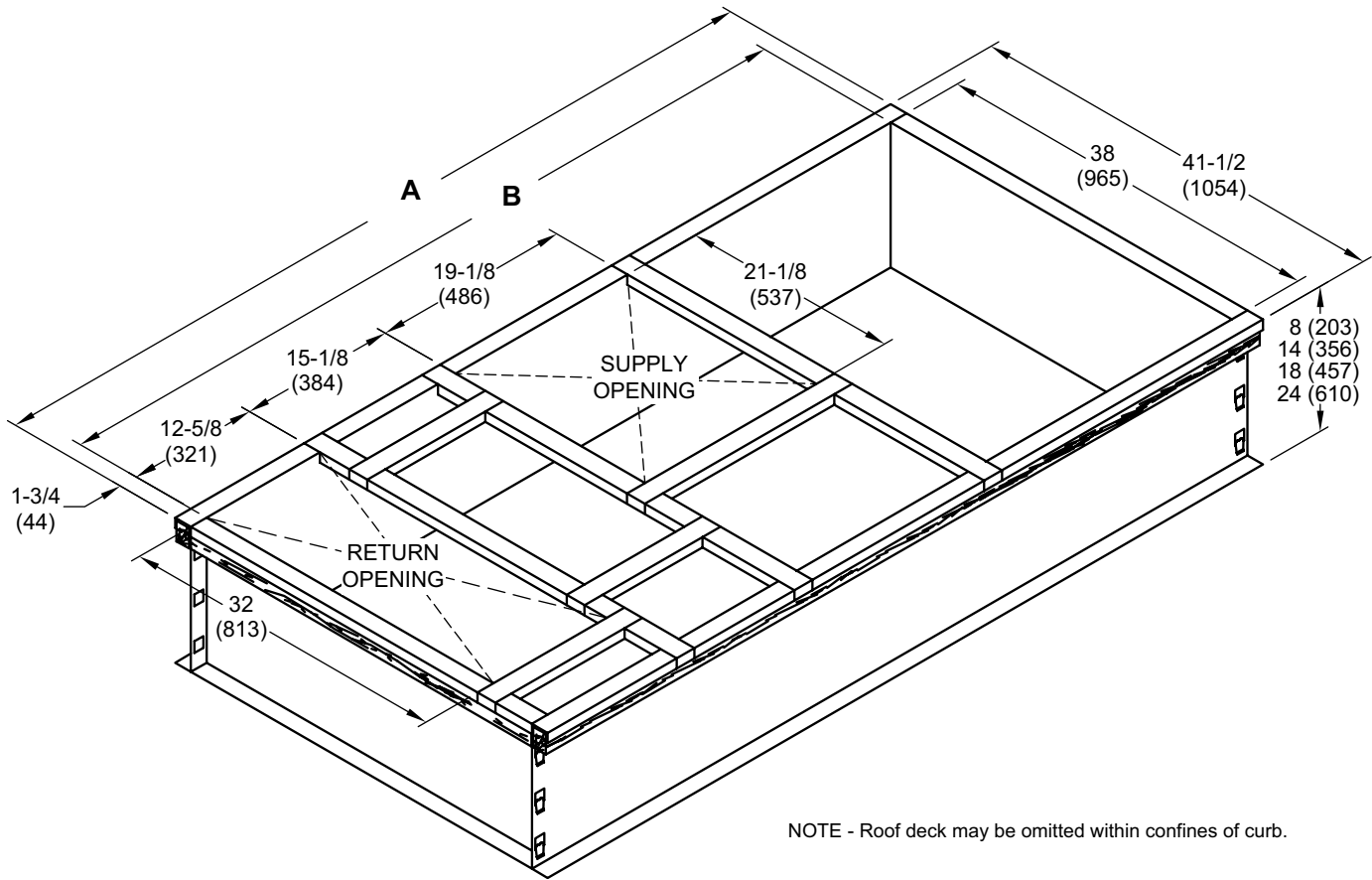

NOTE - Roof deck may be omitted within confines of curb.

### TYPICAL FLASHING DETAIL FOR ROOF CURB

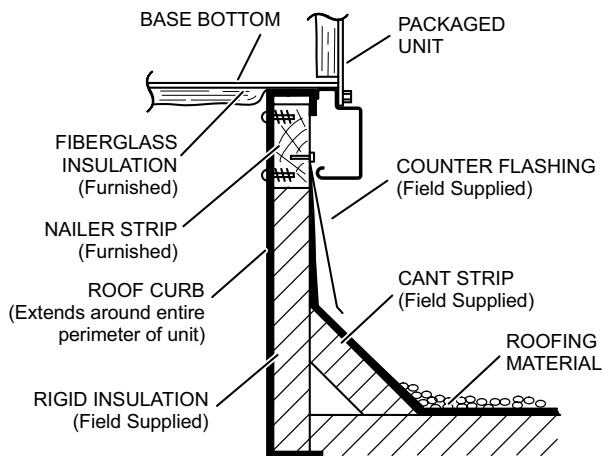

### DETAIL ROOF CURB

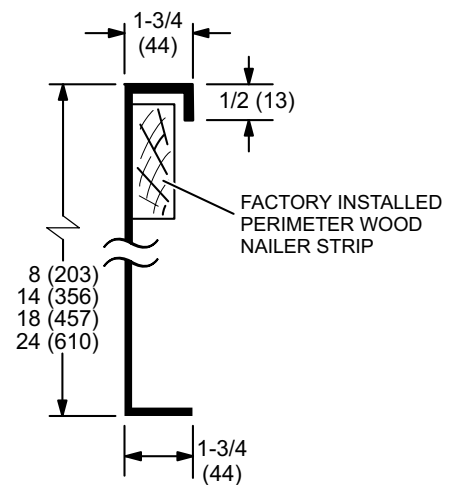

Model No.	A		B	
	in.	mm	in.	mm
Standard - 024, 030, 036, 048, 060, 072, 074, <sup>1</sup> 090	79-3/4	2026	76-1/4	1937
Full Perimeter - 090	92-3/4	2356	89-1/4	2267

<sup>1</sup> 090 models can be used on smaller 79-3/4 in. (2026 mm) roof curbs (not full perimeter) with 15-3/4 in. (400 mm) overhang at condenser end of unit. See dimension drawing on page 66



**DIMENSIONS - ACCESSORIES - INCHES (MM)**

**ADJUSTABLE PITCH CURBS - DOUBLE DUCT OPENING**

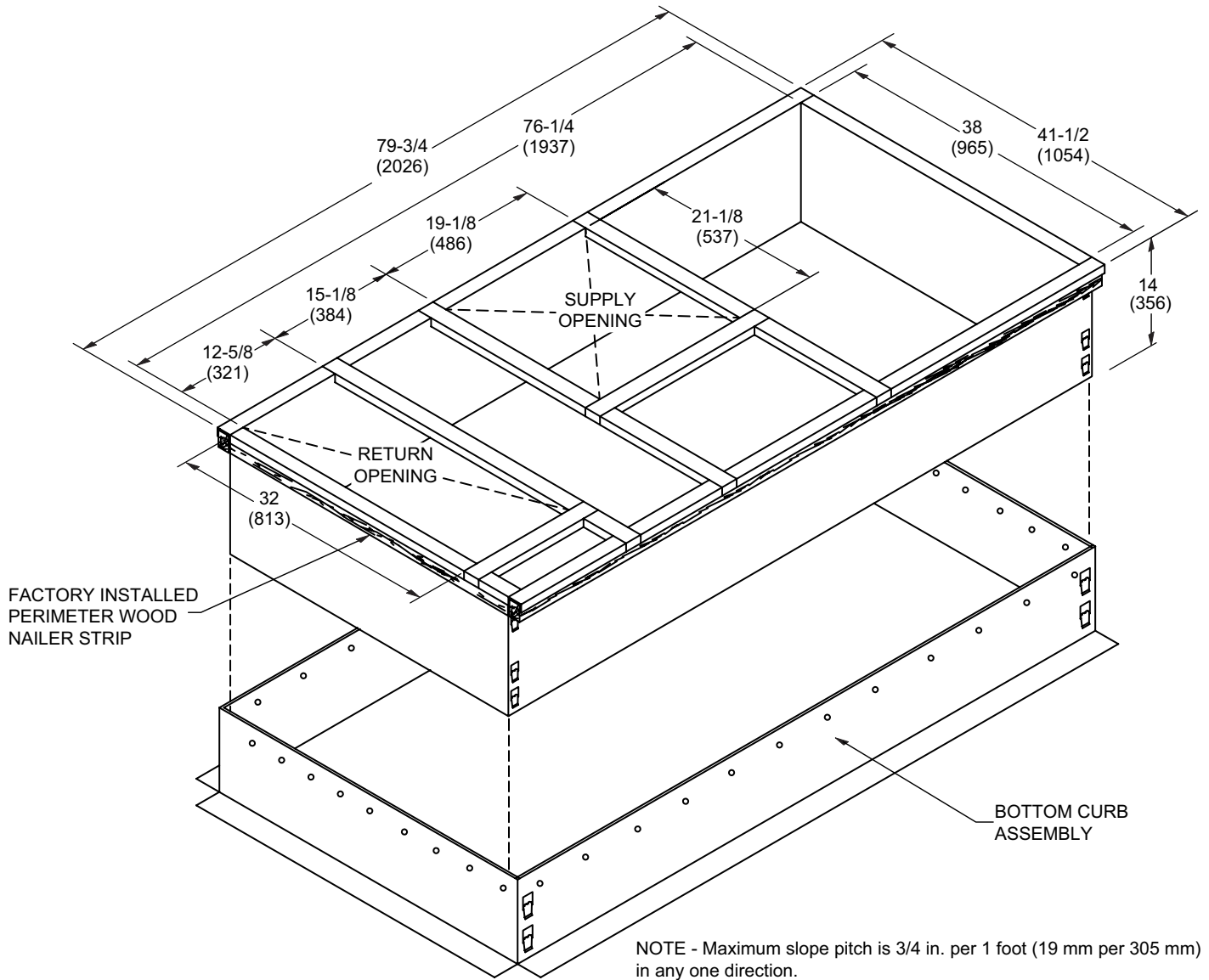

**TYPICAL FLASHING DETAIL FOR ROOF CURB**

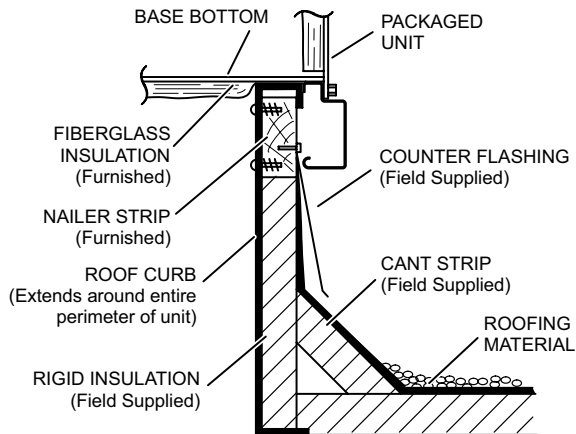

**DETAIL ROOF CURB**

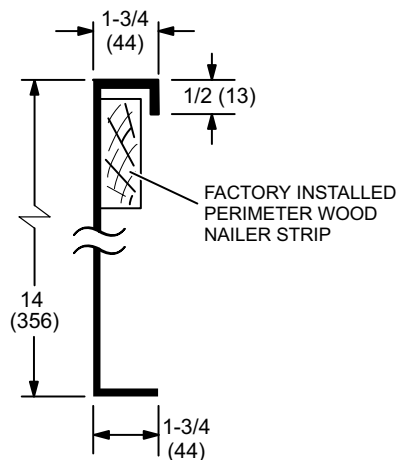

**DIMENSIONS - ACCESSORIES - INCHES (MM)**

**090 MODELS - SHOWING OVERHANG ON SMALLER 79-3/4 INCH LENGTH ROOF CURBS  
(Not Full Perimeter)**

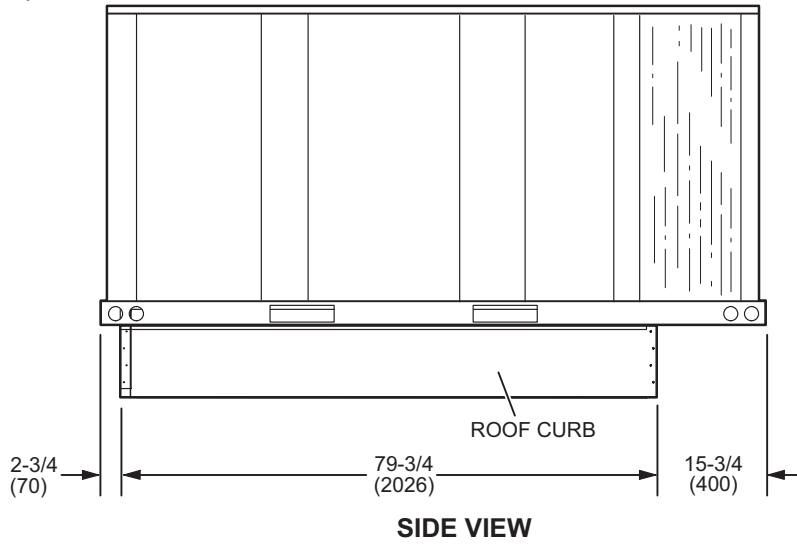

**TRANSITIONS**

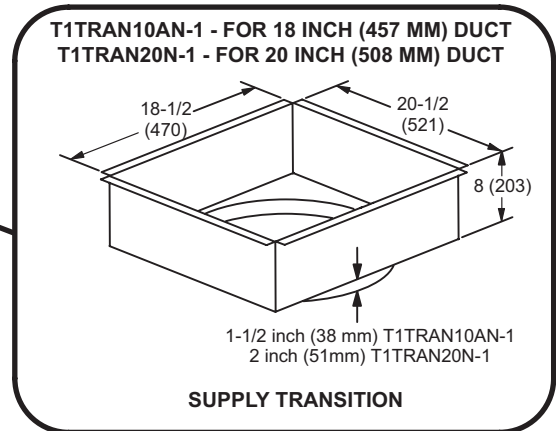
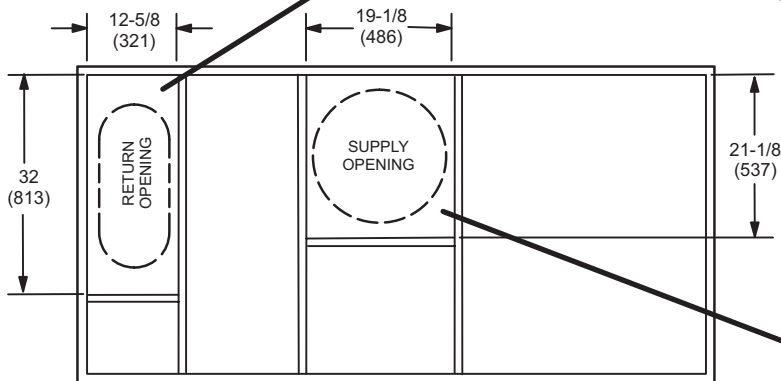
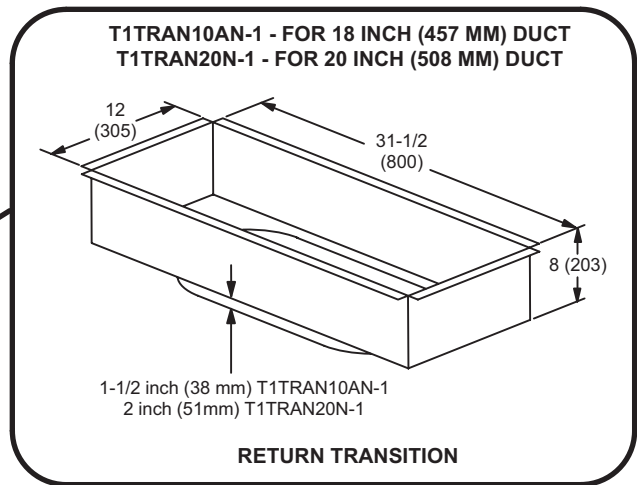

## DIMENSIONS - ACCESSORIES - INCHES (MM)

### COMBINATION CEILING SUPPLY AND RETURN DIFFUSERS

#### STEP-DOWN CEILING DIFFUSER

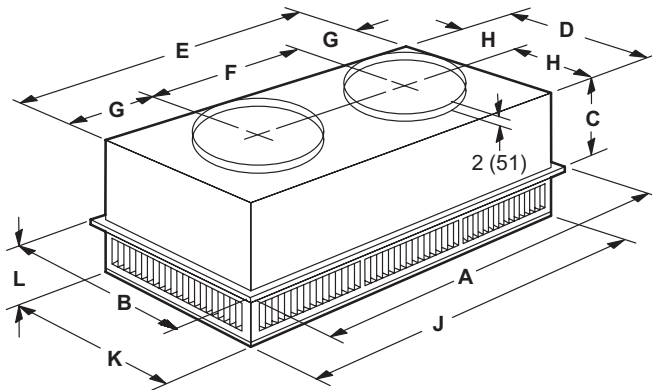

#### FLUSH CEILING DIFFUSER

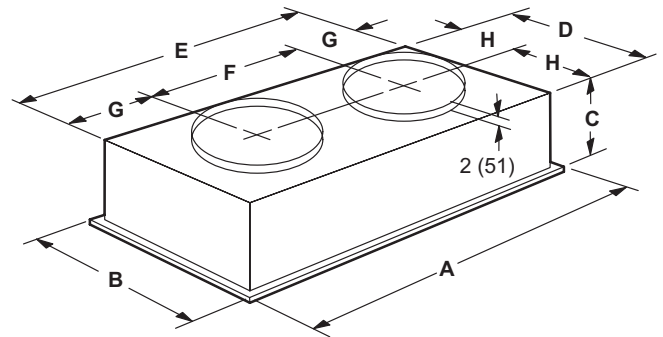

Model Number		RTD9-65S	RTD11-95S
A	in.	47-5/8	47-5/8
	mm	1159	1159
B	in.	23-5/8	29-5/8
	mm	600	752
C	in.	11-3/8	14-3/8
	mm	289	365
D	in.	21-1/2	27-1/2
	mm	546	699
E	in.	45-1/2	45-1/2
	mm	1156	1158
F	in.	22-1/2	22-1/2
	mm	572	572
G	in.	11-1/2	11-1/2
	mm	292	292
H	in.	10-3/4	13-3/4
	mm	273	349
J	in.	45-1/2	45-1/2
	mm	1156	1156
K	in.	21-1/2	27-1/2
	mm	546	699
L	in.	7-1/8	8-1/8
	mm	181	206
Duct Size	in.	18 round	20 round
	mm	457 round	508 round

Model Number		FD9-65S	FD11-95S
A	in.	47-5/8	47-5/8
	mm	1159	1159
B	in.	23-5/8	29-5/8
	mm	600	752
C	in.	13-1/2	16-5/8
	mm	343	422
D	in.	21	27
	mm	533	686
E	in.	45	45
	mm	1143	1143
F	in.	22-1/2	22-1/2
	mm	572	572
G	in.	11-1/4	11-1/4
	mm	286	286
H	in.	10-1/2	13-1/2
	mm	267	343
Duct Size	in.	18 round	20 round
	mm	457 round	508 round





## REVISIONS

Section	Description
Options / Accessories	New Diffuser model and catalog numbers
Weight Data	New diffuser weights



Visit us at [www.lennox.com](http://www.lennox.com)

For the latest technical information, [www.lennoxcommercial.com](http://www.lennoxcommercial.com)

Contact us at 1-800-4-LENNOX

NOTE - Due to Lennox' ongoing commitment to quality, Specifications, Ratings and Dimensions subject to change without notice and without incurring liability. Improper installation, adjustment, alteration, service or maintenance can cause property damage or personal injury. Installation and service must be performed by a qualified installer and servicing agency.

©2016 Lennox Industries, Inc.