

TAG: _____

SUBMITTAL

15 SERIES

Single Zone Mini-Split Inverter System

M4MHW1509A1N0B

M4THS1509A11NB

Specifications

MODEL - Heat Pump Only

	M4HW1509A1 / M4THS1509A1	
	Cooling	Heating
RATED Volts/PH	208 / 230 / 1	
Frequency (Hz)	60Hz	
Rated Cooling / Heating Capacity (Btu/h):	9000	9500
Minimum Cooling Capacity (@95F) (Btu/h):	3100	-
Maximum Cooling Capacity (@95F) (Btu/h):	9600	-
Minimum Heating Capacity (@47F) (Btu/h):	-	3100
Maximum Heating Capacity (@47F) (Btu/h):	-	12000
Maximum Heating Capacity (@17F) (Btu/h):	-	5600
Total Capacity (W) (High/Standard/Low):	2800 / 2600 / 900	3500 / 2700 / 900
Rated Power Input (W)	900	800
Nominal Input Current (A)	4.0	3.6
SEER / HSPF	15.00	9.0
Air Flow Volume (CFM) (SH/H/M/L)	310 / 280 / 240 / 170	
Dehumidifying Volume (pt./h)	1.69	
EER (Btu/W hr)/COP	10.0	11.9

Indoor Unit

	M4MHW1509A1N0
Fan Motor Speed (r/min) (SH/H/M/L)	1350 / 1200 / 1050 / 750 1350 / 1200 / 1050 / 850
Fan Motor RLA(A)	0.20
Evaporator	Aluminum Fin-Copper Tube
Pipe Diameter (inch)	1/5
Row Fin Gap (inch)	2 - 1/18
Coil length (L) x depth (D) x coil width (W) (inch)	23 x 7/8 x 10 1/2
Output of Swing Motor (W)	1.5
Fuse (A)	3.15
Sound Power Level dB (A)(SH/H/M/L)	53 / 49 / 45 / 39
Sound PRESSURE Level dB (A)(SH/H/M/L) ①	43 / 38 / 34 / 28
Uncrated Dimension (W/H/D) (inch)	31 1/9 x 10 5/6 x 7 7/8
Crated Dimension of Package (L/W/H) (inch)	34 x 10 2/3 x 14 4/9
Net Weight /Gross Weight (lbs)	19.8 / 24.2

Outdoor Unit

	M4THS1509A11N
Compressor Type	Swing Rotary
Compressor Oil	DAPHNE FVC50K (PVE Oil)
L.R.A. (A)	16.50
Compressor RLA(A)	6.60
Compressor Power Input(W)	845
Throttling Method	Capillary
Working Temp Range (°F)	0 - 115 -4 - 75
Condenser	Aluminum Fin-Copper Tube
Pipe Diameter (inch)	2/7
Row Fin Gap (inch)	1 - 1/18
Coil length (L) x depth (D) x coil width (W) (inch)	28 x 3/4 x 20
Fan Motor Speed (rpm)	820±20
Output of Fan Motor (W)	30
Fan Motor RLA (A)	0.37
Air Flow Volume of Outdoor Unit (CFM)	942
Fan Diameter (inch)	15 3/4
Defrosting Method	Automatic Defrosting
Sound Power Level dB (A)	62
Sound PRESSURE Level dB (A) ①	52
Uncrated Dimension (W/H/D) (inch)	30 5/9 x 21 1/4 x 12 3/5
Crated Dimension of Package (W/L/H) (inch)	33 1/2 x 14 2/7 x 23 3/7
Net Weight /Gross Weight (lbs)	65.0 / 70.6
Refrigerant Charge (oz)	24.7
MCA	9.0
MOP	15.0

Connection Pipe

Gas additional charge(oz/ft)	0.2
Outer Diameter Liquid Pipe (inch)	1/4
Outer Diameter Gas Pipe (inch)	3/8
Max Height Distance (ft)	65
Max Length Distance (ft)	100

① Sound PRESSURE Level @ 3.3 ft. dB(A)

Unit Dimensions

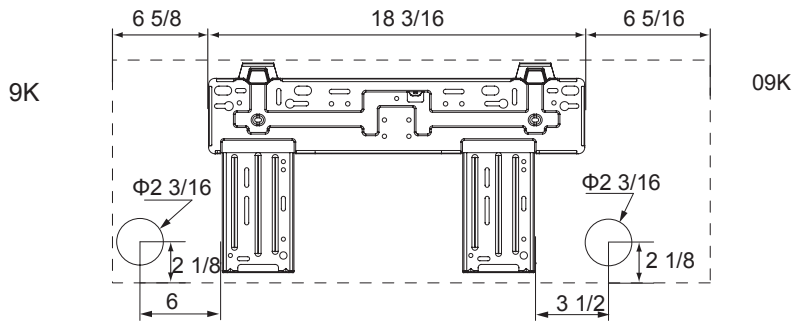
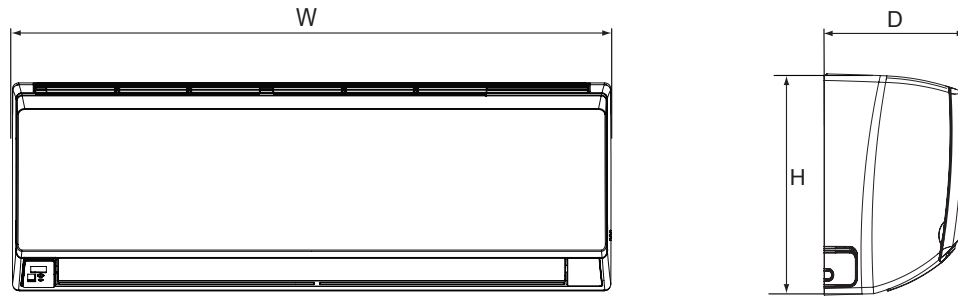

Unit: inch

MODEL	W	H	D
09K	$31 \frac{1}{8}$	$10 \frac{5}{6}$	$7 \frac{7}{8}$
12K	$33 \frac{1}{4}$	$11 \frac{3}{8}$	$8 \frac{1}{4}$

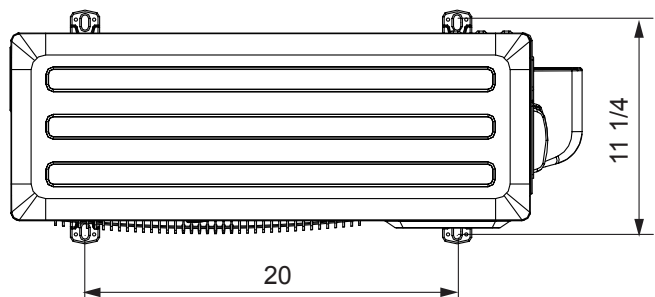
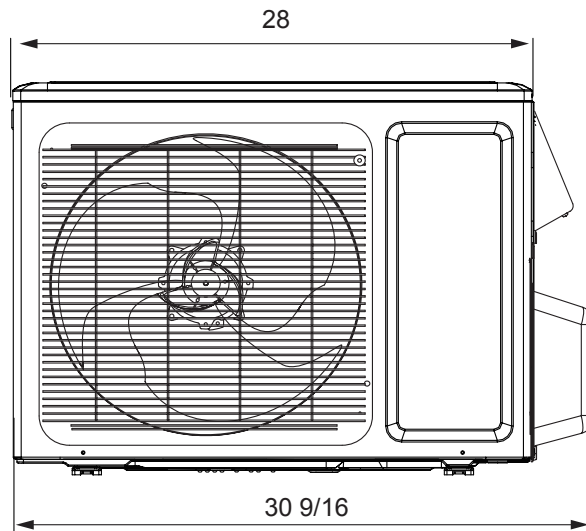
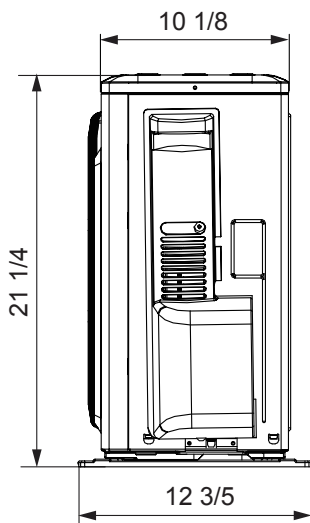

Clearance Requirements

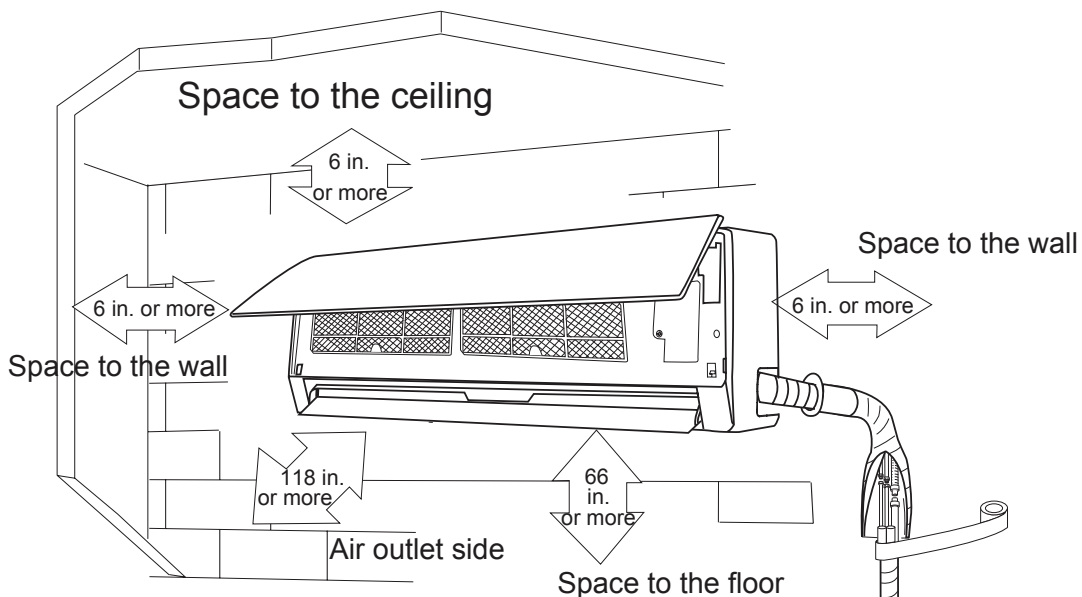

The dimensions of the space necessary for correct installation of the appliance including the minimum permissible distances to adjacent structures

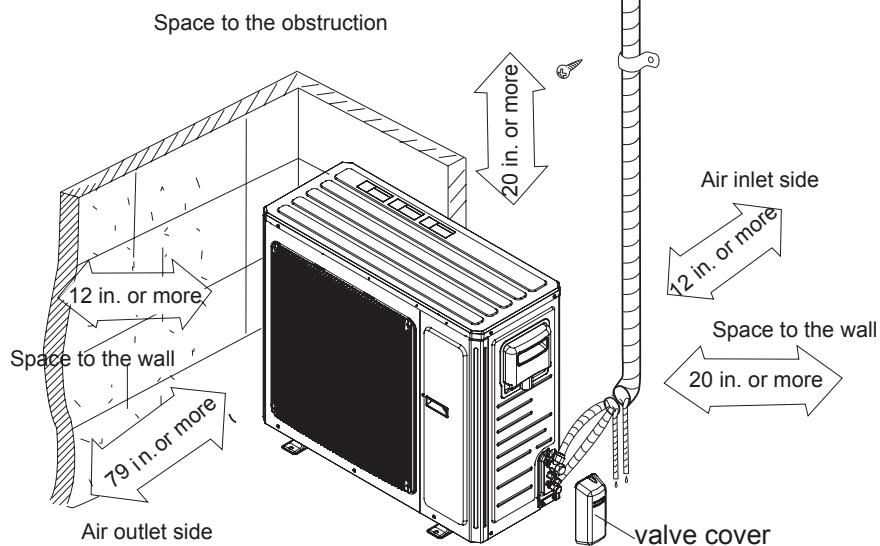

NOTE:

The maximum recommended height from the floor to the bottom of the indoor unit is 11.5 ft. (3.5 m).

Air Velocity Patterns for High Wall		
Max Horizontal Distance		
Unit: ft. (m)		
Model	Cooling Mode	Heating Mode
M4MHW1509A	13.1 (4)	13.1 (4)

Performance Data

COOLING PERFORMANCE

M4MHW1509A
M4THS1509A

Outdoor Ambient Air Temperature (°F)	Indoor Entering Air Temperature (Dry Bulb/Wet Bulb)							
	68/57°F		73/61°F		80/67°F		82/68°F	
	TC*	SHC**	TC	SHC	TC	SHC	TC	SHC
0	1300	1100	1400	1100	1600	1300	1700	1300
10	1600	1300	1700	1300	1900	1500	2000	1600
20	1800	1400	1900	1500	2200	1800	2300	1800
30	1900	1500	2000	1600	2300	1800	2400	1900
40	2000	1600	2100	1700	2400	1900	2400	2000
50	2100	1600	2200	1700	2500	2000	2600	2000
60	2300	1800	2400	2000	2600	2100	2900	2300
70	2500	2100	2700	2200	2900	2400	3100	2500
80	2500	2000	2600	2200	2800	2300	3000	2500
90	2300	1900	2500	2100	2700	2300	2900	2400
100	2200	1800	2300	2000	2600	2200	2800	2400
110	2100	1800	2200	1900	2500	2100	2700	2300
120	1900	1700	2100	1800	2400	2000	2600	2200

*Total Capacity **Sensible Heat Capacity

HEATING PERFORMANCE

M4MHW1509A
M4THS1509A

Outdoor Ambient Air Temperature (°F)	Indoor Entering Air Temperature			
	68°F	73°F	80°F	82°F
	TC*	TC	TC	TC
0	5300	5300	5200	5000
5	5600	5500	5400	5300
10	5900	5800	5700	5500
15	6000	5900	5800	5700
20	6300	6200	6100	6000
25	7000	6900	6700	6600
30	7500	7400	7300	7100
35	8100	8000	7800	7700
40	8700	8600	8500	8300
45	9600	9500	9300	9100
50	9800	9600	9400	9200
55	10000	9800	9600	9400
60	10200	10000	9800	9600
65	10300	10200	10000	9700
70	10500	10300	10100	9800
75	10600	10400	10200	9900

*Total Capacity

Capacities in these performance tables reflect normal operation at the temperatures indicated. See specification tables for certified values under prescribed test conditions.

Mechanical Specifications

Mini-Split Outdoor Unit

General

This unit is fully charged from the factory for up to 25 feet of piping. This unit is designed to operate at outdoor ambient temperatures as high as 115°F. Cooling capacities with the mini-split air handler shown in the catalog are AHRI certified. The unit is ETL listed for outdoor application.

Unit Casing

The unit casing is constructed of heavy gauge, galvanized steel and painted with a weather-resistant powder paint.

Mini-Split Indoor High Wall

General

The High Wall mounted type air handler shall be completely factory assembled including coil, condensate drain pan, fan motor, washable filter, air purifying filter and electric controls to be used with a wireless remote controller. Unit shall be shipped with a unit mounting plate. Unit shall be matched with an outdoor unit, rated and tested in accordance with AHRI standard. Unit shall be ETL listed.

Unit Casing

Casing shall be provided with knockouts on the right, and left of the unit to facilitate piping and electrical connection on either side of the unit. An electrical service cover shall be provided to permit easy access to the electrical terminal strip.

Refrigerant Controls

Refrigeration system controls include condenser fan and compressor relay. High and low pressure controls are inherent to the compressor. A suction line multi function service valve is standard

Compressor

The compressor features internal over temperature and pressure protection; total dipped hermetic motor windings. Other features include: centrifugal oil pump and low vibration and noise.

Condenser Coil

The coil shall consist of aluminum finned coils brazed to copper tubing. The coil provides air flow resistance and efficient heat transfer. The coil is protected by the casing.

Low Ambient Cooling

Matched ductless products, have cooling capabilities at outdoor ambient temperatures as low as 0° F.

Discharge Airflow and Distribution System

Unit shall have auto swing, dual horizontal blades to optimize the aperture outlet for vertical airflow and air distribution. Blade shall close automatically when the air conditioner is turned off to minimize dust entering the unit. Five-Step preset program on the remote controller shall be available to control the blade angle.

Manually adjusted wide-angle louvers shall be provided to adjust the coverage and direction of airflow.

Controls

Units shall have the capability to be controlled remotely through wall-mounted wired options (**sold separately**) as well as a wireless remote option.

Remote Controller

The unit shall have a wireless infrared remote controller with easy reading digital display panel to start, stop and regulate the air conditioner from a distance.

The wireless controller is included with all units.

Healthy Filters

The unit shall have an active carbon and catechin filter with the unit. The filters need to be cleaned at least once a year.

About Trane and American Standard Heating and Air Conditioning

Trane and American Standard create comfortable, energy efficient indoor environments for residential applications. For more information, please visit www.trane.com or www.americanstandardair.com



The AHRI Certified mark indicates company participation in the AHRI Certification program. For verification of individual certified products, go to ahridirectory.org.

The manufacturer has a policy of continuous data improvement and it reserves the right to change design and specifications without notice. We are committed to using environmentally conscious print practices.