



SUBMITTAL DATA - WALL-MOUNTED MPA012S4S-1P - MWMA012S4-1P SINGLE-ZONE MINI-SPLIT HEAT PUMP

Job: _____
 Location: _____
 Schedule No.: _____
 System Designation: _____

Engineer: _____
 Architect: _____
 Date: _____
 For: Reference Approval Review Construction

FEATURES

MPA012S4S-1P

- DC Inverter Control
- Compressor Overcurrent Protection
- Defrost Control

MWMA012S4-1P

- Pre Heat Function
- Multi-Refrigerant Outlet
- Flare Connections
- Refrigerant R-410A
- Auto Restart
- Cooling Override
- LED Display
- Wireless Remote Controller included

Product Warranty

Compressor - Seven year limited warranty.
 All other components - Five year limited warranty.

OUTDOOR SPECIFICATIONS

PERFORMANCE

Cooling Capacity (Btu/h) ¹	12,000
EER	13.00
SEER	21.50
Heating Capacity (Btu/h) ¹	12,000
HSPF	10.00
Outdoor Fan Total Air Volume (cfm)	1180
Ambient Temperature Operating Range	
Cooling	5°F to 122°F
Heating	-13°F to 86°F

ELECTRICAL DATA

Power Supply (V/Hz/Ph)	208-230/60/1
Minimum Circuit Ampacity (A)	15
Maximum Overcurrent Protection (A)	15
Outdoor Fan Motor RLA (A)	0.16
Compressor RLA (A)	5.65
No. of Compressors	1

GENERAL DATA

Connection Ratio (%)	100%
Max. # of Indoor Units	1 unit
Sound Data (dBA) - Cooling/Heating	54 / 57
Refrigerant type	R-410A
Factory refrigerant charge	2 lbs. 12 oz.

DIMENSIONS

Unit Dimensions (in)	Height	22
	Width	34-3/8
	Depth	13-3/4
Shipping Weight (lb)		88
Net Weight (lb)		83

OPTIONAL ACCESSORIES

Non-Programmable Controller (M0STAT61Q-1):	
Wireless Remote Controller (M0STAT60Q-1):	1+

INDOOR SPECIFICATIONS

PERFORMANCE

Airflow (CFM)	High	340
	Medium	260
	Low	205
External Static Pressure (in. w.g.)		-
Sound Pressure (dBA)	High	43.0
	Medium	36.2
	Low	29.3

ELECTRICAL DATA

Power Supply (V/Hz/Φ)	208-230/60/1
Rated load amps (RLA)	0.06
Power Output (W)	20

DIMENSIONS

Unit Dimensions (in)	Height	11
	Width	32-7/8
	Depth	7-7/8
Liquid Pipe Connection (in)		1/4
Gas Pipe Connection (in)		1/2
Condensate drain connection (in)		1
Unit Shipping Weight (lb)		26
Unit Net Weight (lb)		20

NOTES

- Cooling and Heating Capacity data is rated at the following conditions:
 Cooling: 80°FDB / 67°FWB Indoor, 95°FDB Outdoor
 Heating: 70°FDB Indoor, 47°FDB / 43°FWB Indoor



NOTE - Due to Lennox' ongoing commitment to quality, Specifications, Ratings and Dimensions subject to change without notice and without incurring liability. Improper installation, adjustment, alteration, service or maintenance can cause property damage or personal injury. Installation and service must be performed by a qualified installer and servicing agency.



SUBMITTAL DATA - WALL-MOUNTED
MPA012S4S-1P - MWMA012S4-1P
SINGLE-ZONE MINI-SPLIT HEAT PUMP

OUTDOOR DIMENSIONAL DRAWINGS - INCHES (MM)

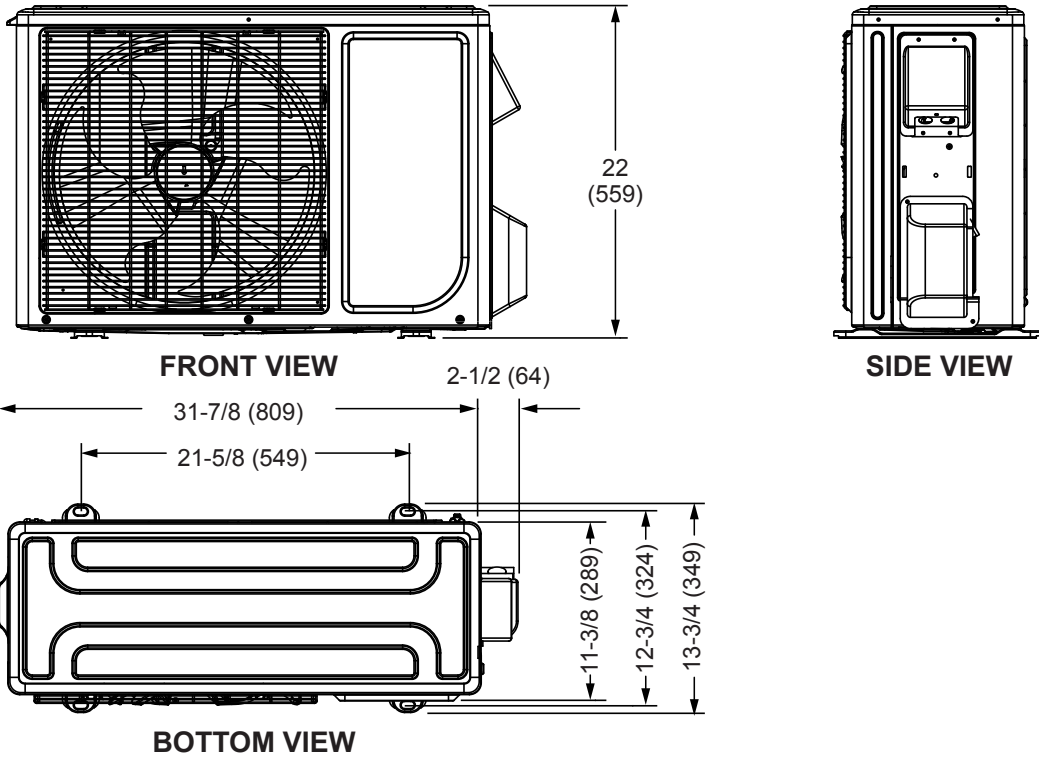

INDOOR DIMENSIONAL DRAWINGS - INCHES (MM)

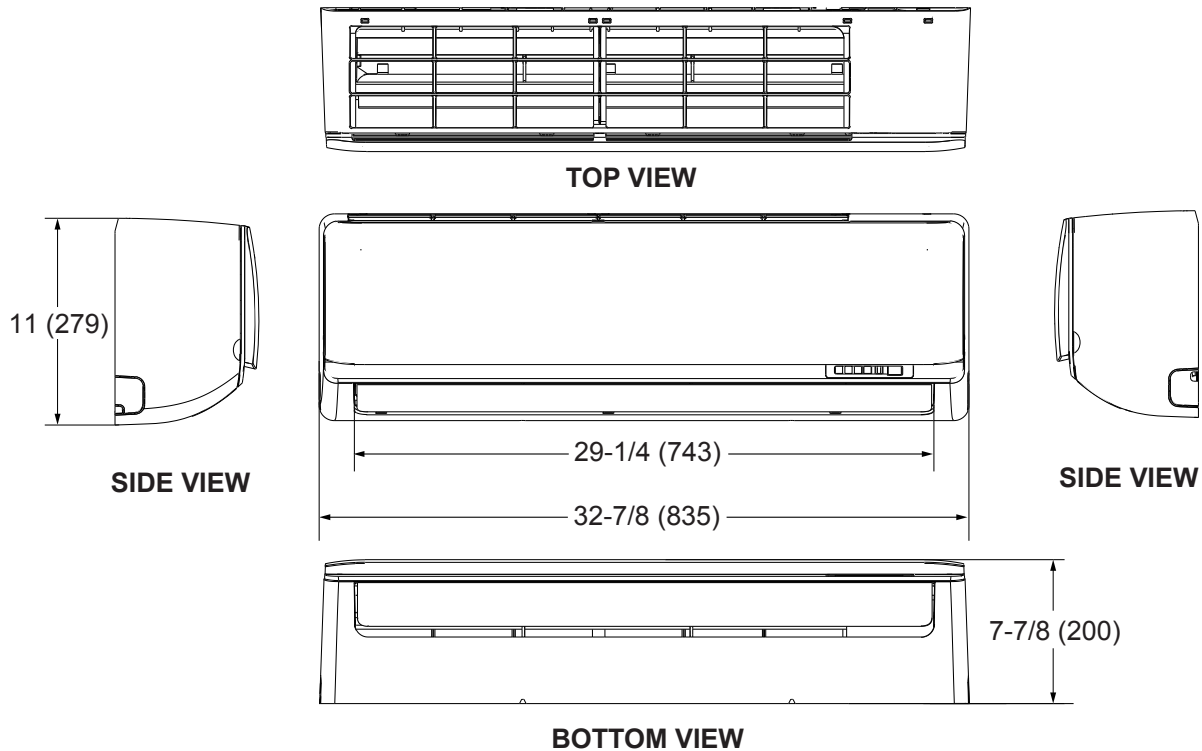

NOTE – Due to Lennox' ongoing commitment to quality, Specifications, Ratings and Dimensions subject to change without notice and without incurring liability. Improper installation, adjustment, alteration, service or maintenance can cause property damage or personal injury. Installation and service must be performed by a qualified installer and servicing agency.