



**NH4H4**

**Product Specifications**

**14 SEER HORIZONTAL DISCHARGE HEAT PUMP FOR USE WITH DUCTED INDOOR UNIT ENVIRONMENTALLY BALANCED R-410A REFRIGERANT**

1-1/2 THRU 5 TONS, 208/230 Volt, 1-Phase

3 THRU 5 TONS, 208/230 Volt, 3-Phase

3 THRU 5 TONS, 460 Volt, 3-Phase

**REFRIGERATION CIRCUIT**

- 14 – 16 SEER/11 – 13 EER/ 8.2 – 9.0 HSPF
- Scroll compressor
- Factory-supplied filter-drier
- High and Low pressure switches
- Line lengths up to 250 feet (76.2m)
- Accumulator

**EASY TO INSTALL AND SERVICE**

- Small footprint
- Easy access service valves on all models
- Factory charged with R-410A refrigerant

**BUILT TO LAST**

- Low ambient operation (down to -0°F/-17.8°C)
- Ball-Bearing Fan Motor

**WARRANTY\***

- 5 year parts limited warranty (including compressor and coil)
  - With timely registration, an additional 5 year parts limited warranty (including compressor and coil)

\* For residential applications only. See warranty certificate for complete details and restrictions, including warranty coverage for other applications.



Use of the AHRI Certified TM Mark indicates a manufacturer's participation in the program. For verification of certification for individual products, go to [www.ahridirectory.org](http://www.ahridirectory.org).



Model Number	Size (tons)	Nominal Btu/hr	Min Circuit Ampacity	Max Fuse or Breaker	Operating Dimensions Height x Width x Depth inches (mm)	Operating/Ship-Weight lbs. (kg)
208/230-1-60						
NH4H418AKA	1½	18,000	11.8	20	25-1/8 x 36-15/16 x 14-9/16 (638 x 938 x 370)	150/170(68/77)
NH4H424AKA	2	24,000	16.5	25	31-1/8 x 36-15/16 x 14-9/16 (790 x 938 x 370)	161/181(73/82)
NH4H430AKA	2½	30,000	17.2	30	37-1/8 x 44-1/2 x 17-1/16 (943 x 1130 x 433)	196/226(89/103)
NH4H436AKA	3	36,000	19.0	30	37-1/8 x 44-1/2 x 17-1/16 (943 x 1130 x 433)	197/227(89/103)
NH4H448AKA	4	48,000	28.8	50	43-1/8 x 44-1/2 x 17-1/16 (1095 x 1130 x 433)	246/276(112/125)
NH4H460AKA	5	60,000	33.4	50	43-1/8 x 44-1/2 x 17-1/16 (1095 x 1130 x 433)	258/288(117/131)
208/230-3-60						
NH4H436AHA	3	36,000	12.8	20	37-1/8 x 44-1/2 x 17-1/16 (943 x 1130 x 433)	197/227(89/103)
NH4H448AHA	4	48,000	18.6	30	43-1/8 x 44-1/2 x 17-1/16 (1095 x 1130 x 433)	246/276(112/125)
NH4H460AHA	5	60,000	22.9	40	43-1/8 x 44-1/2 x 17-1/16 (1095 x 1130 x 433)	258/288(117/131)
460-3-60						
NH4H436ALA	3	36,000	7.6	15	37-1/8 x 44-1/2 x 17-1/16 (943 x 1130 x 433)	197/227(89/103)
NH4H448ALA	4	48,000	8.6	15	43-1/8 x 44-1/2 x 17-1/16 (1095 x 1130 x 433)	246/276(112/125)
NH4H460ALA	5	60,000	10.6	15	43-1/8 x 44-1/2 x 17-1/16 (1095 x 1130 x 433)	258/288(117/131)

**OUTDOOR UNIT MODEL NUMBER IDENTIFICATION GUIDE**

Digit Position:	1,2	3	4	5	6,7	8	9	10	11	12	13
Example Part Number:	<b>NH</b>	<b>4</b>	<b>H</b>	<b>4</b>	<b>18</b>	<b>A</b>	<b>K</b>	<b>A</b>	<b>1</b>	<b>0</b>	<b>0</b>
Horizontal Condenser	<b>UNIT</b>										
4 = R-410A	<b>REFRIGERANT</b>										
A = Air Conditioner H = Heat Pump			<b>TYPE</b>								
4 = 14 SEER			<b>NOMINAL EFFICIENCY</b>								
18 = 18,000 BTUH = 1-1/2 tons 24 = 24,000 BTUH = 2 tons 30 = 30,000 BTUH = 2½ tons 36 = 36,000 BTUH = 3 tons 48 = 48,000 BTUH = 4 tons 60 = 60,000 BTUH = 5 tons					<b>NOMINAL CAPACITY</b>						
A = Standard Grille							<b>FEATURES</b>				
K = 208/230-1-60 H = 208/230-3-60 L = 460-3-60									<b>VOLTAGE</b>		
Sales Code											
Engineering Revision											
Extra Digit											
Extra Digit											

**ACCESSORIES PART NUMBER IDENTIFICATION GUIDE**

Digit Position:	1	2	3	4	5	6, 7	8, 9	10, 11
Example Part Number:	<b>N</b>	<b>A</b>	<b>S</b>	<b>A</b>	<b>0</b>	<b>01</b>	<b>01</b>	<b>CH</b>
N = Non-Branded	<b>BRANDING</b>							
A = Accessory	<b>PRODUCT GROUP</b>							
S = Split System (AC & HP)			<b>KIT USAGE</b>					
A = Original B = 2nd Generation					<b>MAJOR SERIES</b>			
0 = Generic or Not Applicable 2 = R-22 4 = R-410A							<b>REFRIGERANT</b>	
Product Identifier Number								
Package Quantity								
Type of Kit (Example: CH = Crankcase Heater)								

PHYSICAL DATA

UNIT SIZE – SERIES	18AKA	24AKA	30AKA	36AKA, AHA, ALA	48AKA, AHA, ALA	60AKA, AHA, ALA
COMPRESSOR TYPE	Scroll					
REFRIGERANT	R-410A					
Control	TXV (R-410A Hard Shutoff)					
Charge lb (kg)	6.72 (3.05)	7.67 (3.48)	12.07 (5.47)	12.32 (5.59)	10.95 (4.97)	11.82 (5.36)
COND FAN	Propeller Type, Direct Drive					
Air Discharge	Horizontal					
Air Qty (CFM)	1285	1285	2615	2615	2785	2785
Motor HP	1/12	1/12	1/4	1/4	1/4	1/4
Motor RPM	800	800	800	800	800	800
VALVE CONNECT. (In. ID)						
Vapor	5/8	3/4	3/4	7/8	7/8	7/8
Liquid	3/8					
REFRIGERANT TUBES* (In. OD)						
Rated Vapor*	5/8	3/4	3/4	7/8	7/8	1 1/8
Max Liquid Line†	3/8					

\* Units are rated with 25 ft (7.6 m) of lineset length. See Vapor Line Sizing and Cooling Capacity Loss table when using other sizes and lengths of lineset.

Note: See unit Installation Instruction for proper installation.

† See Liquid Line Sizing For Cooling Only Systems with R-410A Refrigerant tables.

VAPOR LINE SIZING AND COOLING CAPACITY LOSS

LONG LINE APPLICATION: An application is considered "Long line" when the total equivalent tubing length exceeds 80 ft. (24.38 m) or when there is more than 20 ft. (6.09 m) vertical separation between indoor and outdoor units. These applications require additional accessories and system modifications for reliable system operation. The maximum allowable total equivalent length is up to 250 ft. (76.2 m). The maximum vertical separation is 200 ft.

(60.96 m) when outdoor unit is above indoor unit, and up to 80 ft. (24.38 m) when the outdoor unit is below the indoor unit. Refer to Accessory Usage Guideline below for required accessories. See Longline Application Guideline for required piping and system modifications. Also, refer to the table below for the vapor tube diameters based on the total length to minimize the cooling capacity loss.

Unit Nominal Size (Btuh)	Maximum Liquid Line Diameters (In.) OD	Vapor Line Diameters (In.) OD	Cooling Capacity Loss (%) Total Equivalent Line Length ft. (m)								
			Standard Application		Long Line Application Requires Accessories						
			26-50 (7.9-15.2)	51-80 (15.5-24.4)	81-100 (24.7-30.5)	101-125 (30.8-38.1)	126-150 (38.4-45.7)	151-175 (46.0-50.3)	176-200 (53.6-60.0)	201-225 (61.3-68.6)	226-250 (68.9-76.2)
18,000 1-Stage R-410A HP	3/8	1/2	1	2	3	4	6	7	8	9	10
		5/8	0	0	1	1	1	2	2	3	3
24,000 1-Stage R-410A HP		5/8	0	1	1	2	3	3	4	4	5
		3/4	0	0	0	0	1	1	1	1	1
30,000 1-Stage R-410A HP		5/8	1	2	3	3	4	5	6	7	8
		3/4	0	0	1	1	1	2	2	2	3
		7/8	0	0	0	0	1	1	1	1	1
36,000 1-Stage R-410A HP		5/8	1	2	4	5	6	7	9	10	11
		3/4	0	0	1	1	2	2	3	3	4
		7/8	0	0	0	0	1	1	1	1	2
48,000 1-Stage R-410A HP		3/4	0	1	2	3	4	5	5	6	7
		7/8	0	0	1	1	2	2	2	3	3
60,000 1-Stage R-410A HP	3/4	1	2	4	5	6	7	9	10	11	
	7/8	0	1	2	2	3	4	4	5	5	
		1-1/8	0	0	0	1	1	1	1	1	1

Applications in this area are long line. Accessories are required as shown recommended on Long Line Application Guidelines  
 Applications in this area may have height restrictions that limit allowable total equivalent length, when outdoor unit is below indoor unit. See Long Line Application Guidelines

### ELECTRICAL DATA

UNIT SIZE – voltage, series	V/PH	OPER VOLTS*		COMPR		FAN	MCA	MAX FUSE** or CKT BRK AMPS
		MAX	MIN	LRA	RLA	FLA		
18AKA	208/230/1	253	197	48.0	9.0	0.50	11.8	20
24AKA				58.3	12.8	0.50	16.5	25
30AKA				64.0	12.8	1.20	17.2	30
36AKA				77.0	14.2	1.20	19.0	30
48AKA				117.0	21.8	1.45	28.8	50
60AKA				144.2	25.5	1.45	33.4	50
36AHA	208/230/3	253	197	71.0	9.3	1.20	12.8	20
48AHA				83.1	13.7	1.45	18.6	30
60AHA				110.0	17.1	1.45	22.9	40
36ALA	460/3	506	414	38.0	5.6	0.60	7.6	15
48ALA				41.0	6.2	0.80	8.6	15
60ALA				52.0	7.8	0.80	10.6	15

**LEGEND:**

- FLA – Full Load Amps
  - HACR – Heating, Air Conditioning, Refrigeration
  - LRA – Locked Rotor Amps
  - NEC – National Electrical Code
  - RLA – Rated Load Amps (compressor)
- \* Permissible limits of the voltage range at which the unit will operate satisfactorily  
 \*\* Time-Delay fuse.  
 Complies with 2007 requirements of ASHRAE Standards 90.1

### A-WEIGHTED SOUND POWER (dBA)

Unit Size	Standard Rating (dBA)	Typical Octave Band Spectrum (dBA, without tone adjustment)						
		125	250	500	1000	2000	4000	8000
18	70	53.5	59.5	61.5	65.5	59.5	55.5	46.0
24	69	53.0	63.0	63.0	62.5	59.0	54.0	50.5
30	72	58.0	61.0	64.0	66.5	64.0	63.5	57.0
36	71	60.5	60.5	64.0	65.5	64.0	62.0	56.5
48	73	60.0	59.0	65.0	68.0	64.0	61.0	55.5
60	74	70.0	62.0	65.0	66.0	64.5	64.0	57.5

NOTE: Tested in accordance with AHRI Standard 270-08 (not listed in AHRI).

### A-WEIGHTED SOUND POWER (dBA) WITH ACCESSORY SOUND SHIELD

Unit Size	Standard Rating (dBA)	Typical Octave Band Spectrum (dBA, without tone adjustment)						
		125	250	500	1000	2000	4000	8000
18	N/A	–	–	–	–	–	–	–
24	N/A	–	–	–	–	–	–	–
30	71	57.5	61.0	63.5	65.5	63.0	63.5	57.0
36	70	59.5	60.5	63.0	64.5	63.0	61.5	56.0
48	72	56.5	59.5	63.5	67.5	64.0	60.5	55.0
60	72	62.0	60.5	64.5	65.0	64.0	63.5	54.5

**NOTES:**

Tested in accordance with AHRI Standard 270-08 (not listed in AHRI).  
 Accessory sound shield will not accommodate unit sizes 18 and 24.

### CHARGING SUBCOOLING (TXV-TYPE EXPANSION DEVICE)

UNIT SIZE-SERIES	REQUIRED SUBCOOLING °F (°C)
18	12 (6.7)
24	14 (7.8)
30	11 (6.1)
36	14 (7.8)
48	11 (6.1)
60	12 (6.7)

# DIMENSIONS – ENGLISH

428 56 9702 02

Specifications subject to change without notice.

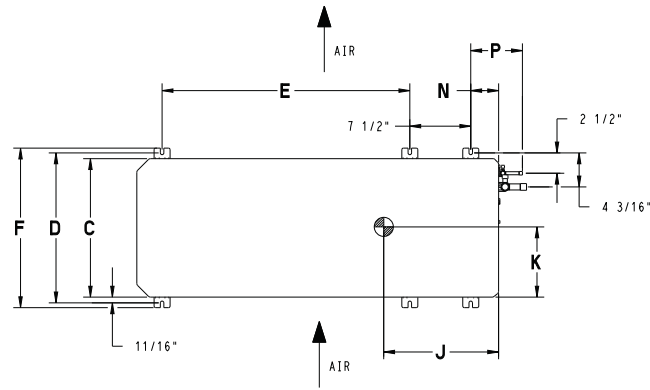

- REQUIRED CLEARANCES: SINGLE UNIT APPLICATIONS: WITH COIL FACING WALL: ALLOW 6 IN. MINIMUM CLEARANCE ON COIL SIDE AND COIL END AND 20 IN. MINIMUM CLEARANCE ON FAN SIDE. ALLOW 24 IN. MINIMUM CLEARANCE ON COMPRESSOR END FOR SERVICE. WITH FAN FACING WALL: ALLOW 8 IN. MINIMUM CLEARANCE ON FAN SIDE AND COIL END AND 20 IN. MINIMUM CLEARANCE ON COIL SIDE. ALLOW 24 IN. MINIMUM CLEARANCE ON COMPRESSOR END FOR SERVICE WHEN UNITS ARE STACKED OR THERE IS LESS THAN 40 IN. OF CLEARANCE ABOVE THE UNIT. IF THERE IS 40 IN. CLEARANCE ABOVE UNIT AND THE TOP PANEL IS ACCESSIBLE FOR REMOVAL ALLOW 8 IN. MINIMUM CLEARANCE ON COMPRESSOR END FOR SERVICE. MULTI-UNIT APPLICATIONS: ALLOW 24 IN. MINIMUM CLEARANCE BETWEEN FAN AND COIL SIDES OF MULTIPLE UNITS. ARRANGE UNITS SO DISCHARGE OF ONE DOES NOT ENTER INLET OF ANOTHER. ALLOW 24 IN. MINIMUM CLEARANCE ON COMPRESSOR END WHEN UNITS ARE STACKED OR THERE IS LESS THAN 40 IN. OF CLEARANCE ABOVE THE UNIT. IF THERE IS 40 IN. CLEARANCE ABOVE UNIT AND THE TOP PANEL IS ACCESSIBLE FOR REMOVAL ALLOW 8 IN. MINIMUM CLEARANCE ON COMPRESSOR END FOR SERVICE. WHEN TWO UNITS ARE INSTALLED END TO END WITH THE COIL ENDS FACING EACH OTHER ALLOW 12 IN. MINIMUM CLEARANCE BETWEEN UNITS.

IMPORTANT: WHEN INSTALLING MULTIPLE UNITS, ENSURE THE DISCHARGE AIR FROM ONE UNIT IS NOT DRAWN INTO ANOTHER UNIT. WHEN INSTALLING SINGLE OR MULTIPLE UNITS IN AN ALCOVE, ROOF WELL, OR PARTIALLY ENCLOSED AREA, ENSURE THERE IS ADEQUATE VENTILATION TO PREVENT RECIRCULATION OF DISCHARGE AIR.

- MINIMUM OUTDOOR OPERATING AMBIENT IN COOLING MODE IS 55°F, MAX. 125°F.
- SERIES DESIGNATION IS THE 11TH POSITION OF THE UNIT MODEL NUMBER.
- CENTER OF GRAVITY
- ALL DIMENSIONS ARE IN "INCHES" UNLESS NOTED.

UNIT SIZE	MINIMUM MOUNTING PAD DIMENSIONS
18,24	23" X 42"
30,36,48,60	24" X 50"

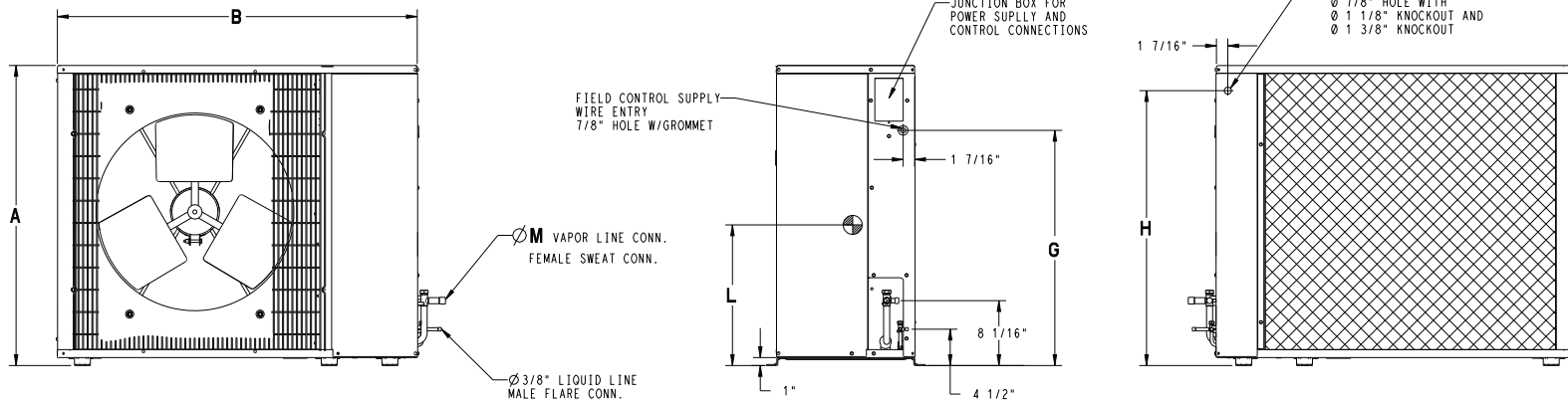

UNIT	SERIES	ELECTRICAL CHARACTERISTICS				A	B	C	D	E	F	G	H	J	K	L	M	N	P	OPERATING WEIGHT(lbs)	SHIPPING WEIGHT(lbs)	SHIPPING DIMENSIONS (L x W x H)											
NH4H418	0	X	0	0	0	25 1/8"	36 15/16"	14 9/16"	16"	23 7/16"	17 3/16"	17 1/8"	22 1/16"	13"	6 5/8"	11 1/4"	5/8"	2 7/8"	4 15/16"	150	170	42 15/16" X 18" X 28 1/8"											
NH4H424	0	X	0	0	0	31 1/8"	36 15/16"	14 9/16"	16"	23 7/16"	17 3/16"	23 1/8"	28 1/16"	14"	6 3/4"	11 5/8"	3/4"	2 7/8"	4 15/16"	161	181	42 15/16" X 18" X 34 1/8"											
NH4H430	0	X	0	0	0	37 1/8"	44 1/2"	17 1/16"	18 7/16"	30 1/2"	19 5/8"	29 1/8"	34 1/16"	13 11/16"	8 1/8"	15 7/8"	3/4"	3 3/8"	5 1/2"	196	226	50 1/2" X 20 1/2" X 40 1/8"											
NH4H436	0	X	0	X	X	37 1/8"	44 1/2"	17 1/16"	18 7/16"	30 1/2"	19 5/8"	29 1/8"	34 1/16"	13 11/16"	8 1/8"	15 7/8"	7/8"	3 3/8"	5 1/2"	197	227	50 1/2" X 20 1/2" X 40 1/8"											
NH4H448	0	X	0	X	X	43 1/8"	44 1/2"	17 1/16"	18 7/16"	30 1/2"	19 5/8"	35 1/8"	40 1/16"	14 1/2"	8 1/2"	18 7/8"	7/8"	3 3/8"	5 1/2"	246	276	50 1/2" X 20 1/2" X 46 1/8"											
NH4H460	0	X	0	X	X	43 1/8"	44 1/2"	17 1/16"	18 7/16"	30 1/2"	19 5/8"	35 1/8"	40 1/16"	14 1/2"	8 1/2"	18 7/8"	7/8"	3 3/8"	5 1/2"	258	288	50 1/2" X 20 1/2" X 46 1/8"											
		<table border="1"> <tr> <td>208-230-160</td> <td></td> </tr> <tr> <td>230-160</td> <td></td> </tr> <tr> <td>208/230-3-60</td> <td></td> </tr> <tr> <td>460-3-60</td> <td></td> </tr> </table>				208-230-160		230-160		208/230-3-60		460-3-60		X = YES O = NO																			
208-230-160																																	
230-160																																	
208/230-3-60																																	
460-3-60																																	

# DIMENSIONS – SI

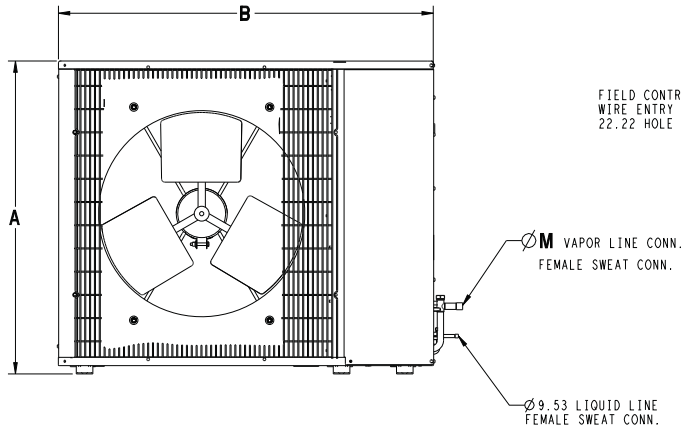
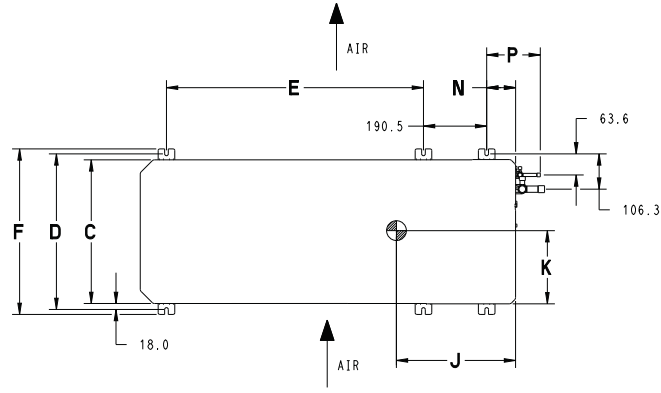

- REQUIRED CLEARANCES: SINGLE UNIT APPLICATIONS: WITH COIL FACING WALL: ALLOW 152.4 mm MINIMUM CLEARANCE ON COIL SIDE AND COIL END AND 504.0 mm MINIMUM CLEARANCE ON FAN SIDE. ALLOW 609.6 mm MINIMUM CLEARANCE ON COMPRESSOR END FOR SERVICE. WITH FAN FACING WALL: ALLOW 203.2 mm MINIMUM CLEARANCE ON FAN SIDE AND COIL END AND 504.0 mm MINIMUM CLEARANCE ON COIL SIDE. ALLOW 609.6 mm MINIMUM CLEARANCE ON COMPRESSOR END FOR SERVICE WHEN UNITS ARE STACKED OR THERE IS LESS THAN 1016 mm OF CLEARANCE ABOVE THE UNIT. IF THERE IS 1016 mm CLEARANCE ABOVE UNIT AND THE TOP PANEL IS ACCESSIBLE FOR REMOVAL ALLOW 203.2 mm MINIMUM CLEARANCE ON COMPRESSOR END FOR SERVICE. MULTI-UNIT APPLICATIONS: ALLOW 609.6 mm MINIMUM CLEARANCE BETWEEN FAN AND COIL SIDES OF MULTIPLE UNITS. ARRANGE UNITS SO DISCHARGE OF ONE DOES NOT ENTER INLET OF ANOTHER. ALLOW 609.6 mm MINIMUM CLEARANCE ON COMPRESSOR END WHEN UNITS ARE STACKED OR THERE IS LESS THAN 1016 mm OF CLEARANCE ABOVE THE UNIT. IF THERE IS 1016 mm CLEARANCE ABOVE UNIT AND THE TOP PANEL IS ACCESSIBLE FOR REMOVAL ALLOW 203.2 mm MINIMUM CLEARANCE ON COMPRESSOR END FOR SERVICE. WHEN TWO UNITS ARE INSTALLED END TO END WITH THE COIL ENDS FACING EACH OTHER ALLOW 304.8 mm MINIMUM CLEARANCE BETWEEN UNITS.

IMPORTANT: WHEN INSTALLING MULTIPLE UNITS, ENSURE THE DISCHARGE AIR FROM ONE UNIT IS NOT DRAWN INTO ANOTHER UNIT. WHEN INSTALLING SINGLE OR MULTIPLE UNITS IN AN ALCOVE, ROOF WELL, OR PARTIALLY ENCLOSED AREA, ENSURE THERE IS ADEQUATE VENTILATION TO PREVENT RECIRCULATION OF DISCHARGE AIR.

- MINIMUM OUTDOOR OPERATING AMBIENT IN COOLING MODE IS 12.8°C, MAX. 51.7°C.
- SERIES DESIGNATION IS THE 11TH POSITION OF THE UNIT MODEL NUMBER.
- CENTER OF GRAVITY
- ALL DIMENSIONS ARE IN "MM" UNLESS NOTED.

UNIT SIZE	MINIMUM MOUNTING PAD DIMENSIONS
18,24	584.2 X 1066.8
30,36,48,60	609.6 X 1270.0

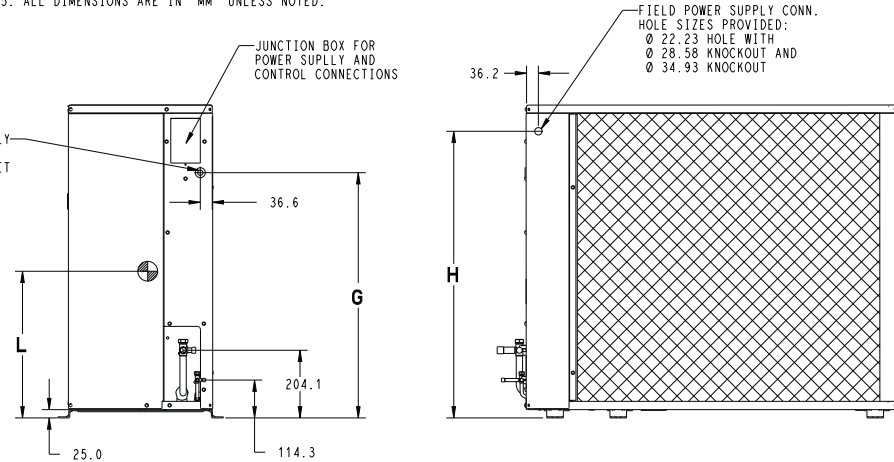

Specifications subject to change without notice.

UNIT	SERIES	ELECTRICAL CHARACTERISTICS				A	B	C	D	E	F	G	H	J	K	L	M	N	P	OPERATING WEIGHT(lbs)	SHIPPING WEIGHT(lbs)	SHIPPING DIMENSIONS (L x W x H)	
NH4H418	0	X	0	0	0	25 1/8"	36 15/16"	14 9/16"	16"	23 7/16"	17 3/16"	17 1/8"	22 1/16"	13"	6 5/8"	11 1/4"	5/8"	2 7/8"	4 15/16"	150	170	42 15/16" X 18" X 28 1/8"	
NH4H424	0	X	0	0	0	31 1/8"	36 15/16"	14 9/16"	16"	23 7/16"	17 3/16"	23 1/8"	28 1/16"	14"	6 3/4"	11 5/8"	3/4"	2 7/8"	4 15/16"	161	181	42 15/16" X 18" X 34 1/8"	
NH4H430	0	X	0	0	0	37 1/8"	44 1/2"	17 1/16"	18 7/16"	30 1/2"	19 5/8"	29 1/8"	34 1/16"	13 11/16"	8 1/8"	15 7/8"	3/4"	3 3/8"	5 1/2"	196	226	50 1/2" X 20 1/2" X 40 1/8"	
NH4H436	0	X	0	X	X	37 1/8"	44 1/2"	17 1/16"	18 7/16"	30 1/2"	19 5/8"	29 1/8"	34 1/16"	13 11/16"	8 1/8"	15 7/8"	7/8"	3 3/8"	5 1/2"	197	227	50 1/2" X 20 1/2" X 40 1/8"	
NH4H448	0	X	0	X	X	43 1/8"	44 1/2"	17 1/16"	18 7/16"	30 1/2"	19 5/8"	35 1/8"	40 1/16"	14 1/2"	8 1/2"	18 7/8"	7/8"	3 3/8"	5 1/2"	246	276	50 1/2" X 20 1/2" X 46 1/8"	
NH4H460	0	X	0	X	X	43 1/8"	44 1/2"	17 1/16"	18 7/16"	30 1/2"	19 5/8"	35 1/8"	40 1/16"	14 1/2"	8 1/2"	18 7/8"	7/8"	3 3/8"	5 1/2"	258	288	50 1/2" X 20 1/2" X 46 1/8"	
		208-232-80	230-160	208-232-208	460-360	X = YES O = NO																	

428 56 9702 02

L15S004

# BALANCE POINT WORKSHEET

428 56 9702 02

Specifications subject to change without notice.

7

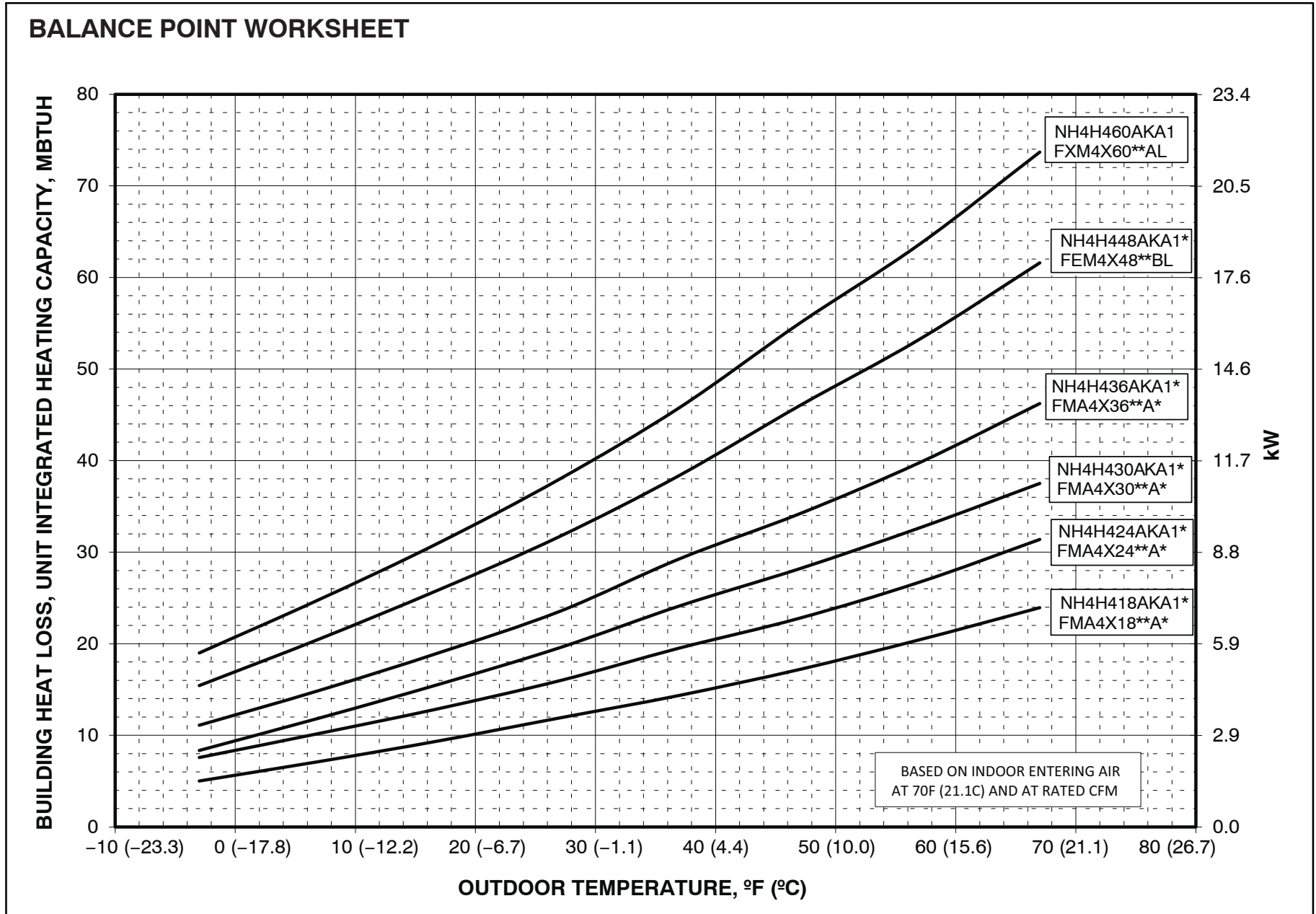

**TESTED AHRI COMBINATION RATINGS\***

Or scan this QR code:

NOTE: Ratings contained in this document are subject to change at any time.

For AHRI ratings certificates, please refer to the AHRI directory. [www.ahridirectory.org](http://www.ahridirectory.org)

Additional ratings and system combinations can be accessed via the Keeprite database:

<http://www.icpeqp.com/AHRIratings/ratings.aspx?Brand=Keeprite>



Model Number	Indoor Coil Model Number	Furnace Model Number	Cooling Capacity	EER	SEER	High Temp		HSPF	Low Temp	
						Capacity 47°F (8°C)	COP		Capacity 17°F (-8°C)	COP
NH4H418AKA1*	FMA4X18**A*		18,000	11.5	14	17,200	3.80	8.2	10,400	2.48
NH4H424AKA1*	FMA4X24**A*		23,400	11.5	14	22,800	3.74	8.2	13,800	2.50
NH4H430AKA1*	FMA4X30**A*		28,800	12.5	15	28,200	4.02	8.5	17,500	2.62
NH4H436AKA1*	FMA4X36**A*		34,200	12.0	14	34,200	3.94	8.5	21,000	2.60
NH4H436AHA1*	FMA4X36**A*		34,200	12.0	14	34,200	3.94	8.5	21,000	2.60
NH4H436ALA1*	FMA4X36**A*		34,200	12.0	14	34,200	3.94	8.5	21,000	2.60
NH4H448AKA1*	FEM4X48**BL		45,500	11.5	14	46,000	3.66	8.2	29,000	2.56
NH4H448AHA1*	FEM4X48**BL		45,500	11.5	14	46,000	3.66	8.2	29,000	2.56
NH4H448ALA1*	FEM4X48**BL		45,500	11.5	14	46,000	3.66	8.2	29,000	2.56
NH4H460AKA1*	FXM4X60**AL		55,000	11.5	14	55,000	3.78	8.2	33,600	2.62
NH4H448AHA1*	FXM4X60**AL		55,000	11.5	14	55,000	3.78	8.2	33,600	2.62
NH4H460ALA1*	FXM4X60**AL		55,000	11.5	14	55,000	3.78	8.2	33,600	2.62

**EER** — Energy Efficiency Ratio

**SEER** — Seasonal Energy Efficiency Ratio

**TXV** — Thermostatic Expansion Valve

**NOTES:**

1. Ratings are net values reflecting the effects of circulating fan motor heat. Supplemental electric heat is not included.
2. Tested outdoor/indoor combinations have been tested in accordance with DOE test procedures for central air conditioners. Ratings for other combinations are determined under DOE computer simulation procedures.
3. Determine actual CFM values obtainable for your system by referring to fan performance data in fan coil or furnace coil literature.
4. Do not apply with capillary tube coils as performance and reliability are significantly affected.

# DETAILED COOLING CAPACITIES

428 56 9702 02

Specifications subject to change without notice.

Evaporator Air		CONDENSER ENTERING AIR TEMPERATURES °F (°C)																							
		75 (23.9)				85 (29.4)				95 (35)				105 (40.6)				115 (46.1)				125 (51.7)			
		CFM	EWB °F (°C)	Capacity MBtu/h†		Total System KW**	Capacity MBtu/h†		Total System KW**	Capacity MBtu/h†		Total System KW**	Capacity MBtu/h†		Total System KW**	Capacity MBtu/h†		Total System KW**	Capacity MBtu/h†		Total System KW**				
Total	Sens†			Total	Sens†		Total	Sens†		Total	Sens†		Total	Sens†		Total	Sens†								
<b>NH4H418AKA1* Outdoor Section With FMA4X18**A* Indoor Section</b>																									
525	72 (22.2)	21.77	11.33	1.24	20.66	10.90	1.40	19.51	10.46	1.57	18.30	10.01	1.75	17.02	9.54	1.96	15.68	9.06	2.19						
	67 (19.4)	19.71	13.86	1.23	18.70	13.43	1.38	17.64	12.99	1.55	16.54	12.54	1.73	15.37	12.07	1.94	14.15	11.58	2.17						
	63 (17.2)	18.24	13.32	1.22	17.30	12.89	1.37	16.31	12.45	1.53	15.28	11.99	1.72	14.19	11.52	1.92	13.05	11.04	2.15						
	62 (16.7)	17.90	16.38	1.22	17.00	15.96	1.37	16.05	15.52	1.53	15.09	15.01	1.72	14.22	14.22	1.92	13.29	13.29	2.16						
	57 (13.9)	17.35	17.35	1.21	16.63	16.63	1.37	15.87	15.87	1.53	15.06	15.06	1.72	14.20	14.20	1.92	13.27	13.27	2.16						
600	72 (22.2)	22.25	11.92	1.26	21.10	11.49	1.41	19.88	11.04	1.58	18.62	10.59	1.77	17.29	10.11	1.98	15.91	9.62	2.21						
	67 (19.4)	20.16	14.81	1.24	19.11	14.37	1.40	18.00	13.92	1.57	16.85	13.47	1.75	15.64	12.99	1.96	14.38	12.49	2.19						
	63 (17.2)	18.67	14.21	1.24	17.69	13.77	1.39	16.66	13.32	1.55	15.58	12.86	1.74	14.46	12.38	1.94	13.28	11.88	2.17						
	62 (16.7)	18.38	17.69	1.23	17.47	17.25	1.39	16.60	16.60	1.55	15.73	15.73	1.74	14.80	14.80	1.94	13.81	13.81	2.18						
	57 (13.9)	18.16	18.16	1.23	17.39	17.39	1.39	16.57	16.57	1.55	15.71	15.71	1.74	14.78	14.78	1.94	13.79	13.79	2.18						
675	72 (22.2)	22.63	12.49	1.27	21.42	12.05	1.43	20.17	11.60	1.60	18.87	11.13	1.79	17.50	10.65	2.00	16.07	10.16	2.23						
	67 (19.4)	20.52	15.72	1.26	19.42	15.28	1.41	18.28	14.83	1.58	17.10	14.36	1.77	15.85	13.88	1.97	14.56	13.37	2.20						
	63 (17.2)	19.01	15.06	1.25	17.99	14.62	1.40	16.93	14.16	1.57	15.82	13.69	1.75	14.66	13.20	1.96	13.46	12.69	2.19						
	62 (16.7)	18.87	18.87	1.25	18.06	18.06	1.40	17.19	17.19	1.57	16.27	16.27	1.76	15.28	15.28	1.97	14.24	14.24	2.20						
	57 (13.9)	18.85	18.85	1.25	18.03	18.03	1.40	17.16	17.16	1.57	16.24	16.24	1.76	15.26	15.26	1.96	14.22	14.22	2.20						

Evaporator Air		CONDENSER ENTERING AIR TEMPERATURES °F (°C)																							
		75 (23.9)				85 (29.4)				95 (35)				105 (40.6)				115 (46.1)				125 (51.7)			
		CFM	EWB °F (°C)	Capacity MBtu/h†		Total System KW**	Capacity MBtu/h†		Total System KW**	Capacity MBtu/h†		Total System KW**	Capacity MBtu/h†		Total System KW**	Capacity MBtu/h†		Total System KW**	Capacity MBtu/h†		Total System KW**				
Total	Sens†			Total	Sens†		Total	Sens†		Total	Sens†		Total	Sens†		Total	Sens†								
<b>NH4H424AKA1* Outdoor Section With FMA4X24**A* Indoor Section</b>																									
700	72 (22.2)	28.58	14.75	1.68	27.22	14.23	1.87	25.78	13.70	2.09	24.23	13.12	2.32	22.56	12.51	2.58	20.77	11.87	2.87						
	67 (19.4)	25.98	18.17	1.63	24.74	17.65	1.82	23.40	17.10	2.03	21.96	16.51	2.27	20.41	15.89	2.53	18.76	15.23	2.82						
	63 (17.2)	24.11	17.49	1.60	22.95	16.97	1.79	21.70	16.41	2.00	20.34	15.81	2.24	18.88	15.19	2.50	17.32	14.52	2.80						
	62 (16.7)	23.68	21.57	1.60	22.57	21.05	1.79	21.38	20.49	2.00	20.13	19.94	2.24	18.94	18.94	2.51	17.66	17.66	2.80						
	57 (13.9)	23.03	23.03	1.59	22.13	22.13	1.78	21.15	21.15	2.00	20.08	20.08	2.24	18.91	18.91	2.51	17.63	17.63	2.80						
800	72 (22.2)	29.13	15.49	1.72	27.73	14.97	1.91	26.22	14.42	2.13	24.61	13.83	2.36	22.88	13.21	2.62	21.03	12.56	2.90						
	67 (19.4)	26.50	19.36	1.66	25.20	18.83	1.86	23.81	18.27	2.07	22.32	17.68	2.31	20.73	17.05	2.57	19.02	16.39	2.85						
	63 (17.2)	24.61	18.60	1.63	23.40	18.06	1.83	22.09	17.50	2.04	20.69	16.90	2.27	19.19	16.27	2.54	17.58	15.59	2.83						
	62 (16.7)	24.27	23.23	1.63	23.14	22.67	1.82	22.03	22.03	2.04	20.89	20.89	2.28	19.64	19.64	2.55	18.29	18.29	2.84						
	57 (13.9)	24.01	24.01	1.63	23.05	23.05	1.82	22.00	22.00	2.04	20.86	20.86	2.28	19.61	19.61	2.55	18.26	18.26	2.84						
900	72 (22.2)	29.55	16.19	1.76	28.10	15.66	1.95	26.55	15.10	2.16	24.89	14.51	2.40	23.11	13.89	2.65	21.21	13.23	2.94						
	67 (19.4)	26.89	20.50	1.70	25.55	19.97	1.89	24.12	19.40	2.11	22.60	18.81	2.34	20.97	18.17	2.60	19.23	17.49	2.89						
	63 (17.2)	24.99	19.66	1.67	23.74	19.12	1.86	22.40	18.55	2.07	20.97	17.95	2.31	19.43	17.30	2.57	17.79	16.60	2.86						
	62 (16.7)	24.83	24.83	1.66	23.84	23.84	1.86	22.73	22.73	2.08	21.53	21.53	2.32	20.22	20.22	2.58	18.80	18.80	2.88						
	57 (13.9)	24.83	24.83	1.66	23.81	23.81	1.86	22.70	22.70	2.08	21.50	21.50	2.32	20.19	20.19	2.58	18.78	18.78	2.88						

See notes on pg. 11

# DETAILED COOLING CAPACITIES(CONT.)

10

Evaporator Air		CONDENSER ENTERING AIR TEMPERATURES °F (°C)																							
CFM	EWB °F (°C)	75 (23.9)				85 (29.4)				95 (35)				105 (40.6)				115 (46.1)				125 (51.7)			
		Capacity MBtu/h†		Total System KW**	Capacity MBtu/h†		Total System KW**	Capacity MBtu/h†		Total System KW**	Capacity MBtu/h†		Total System KW**	Capacity MBtu/h†		Total System KW**	Capacity MBtu/h†		Total System KW**						
		Total	Sens†		Total	Sens†		Total	Sens†		Total	Sens†		Total	Sens†		Total	Sens†							
<b>NH4H430AKA1* Outdoor Section With FMA4X30**A* Indoor Section</b>																									
875	72 (22.2)	35.68	17.88	1.86	33.43	17.10	2.05	31.12	16.32	2.26	28.69	15.50	2.51	26.11	14.65	2.78	23.35	13.76	3.09						
	67 (19.4)	32.54	22.42	1.87	30.52	21.65	2.06	28.40	20.86	2.28	26.19	20.04	2.52	23.85	19.19	2.80	21.34	18.27	3.11						
	63 (17.2)	30.26	21.54	1.88	28.41	20.79	2.07	26.46	20.00	2.29	24.39	19.18	2.53	22.20	18.31	2.81	19.89	17.39	3.12						
	62 (16.7)	29.91	26.93	1.88	28.23	28.08	2.07	26.61	26.61	2.29	24.86	24.86	2.53	22.99	22.99	2.80	20.94	20.94	3.11						
	57 (13.9)	29.67	29.67	1.88	28.17	28.17	2.07	26.57	26.57	2.29	24.82	24.82	2.53	22.96	22.96	2.80	20.91	20.91	3.11						
1000	72 (22.2)	36.23	18.82	1.88	33.89	18.03	2.07	31.51	17.24	2.29	29.00	16.41	2.53	26.34	15.55	2.80	23.51	14.63	3.11						
	67 (19.4)	33.09	23.97	1.90	30.99	23.19	2.09	28.80	22.39	2.30	26.52	21.55	2.55	24.12	20.67	2.82	21.59	19.69	3.13						
	63 (17.2)	30.81	23.00	1.90	28.88	22.23	2.10	26.86	21.42	2.31	24.72	20.57	2.56	22.50	19.68	2.83	20.18	20.07	3.14						
	62 (16.7)	30.86	30.86	1.90	29.25	29.25	2.10	27.52	27.52	2.31	25.67	25.67	2.55	23.69	23.69	2.82	21.51	21.51	3.13						
	57 (13.9)	30.82	30.82	1.90	29.21	29.21	2.10	27.48	27.48	2.31	25.63	25.63	2.55	23.66	23.66	2.82	21.49	21.49	3.13						
1125	72 (22.2)	36.64	19.72	1.91	34.23	18.92	2.10	31.79	18.11	2.31	29.23	17.28	2.55	26.50	16.40	2.83	23.60	15.48	3.14						
	67 (19.4)	33.51	25.48	1.92	31.35	24.68	2.11	29.09	23.85	2.33	26.78	22.99	2.57	24.36	22.04	2.85	21.98	21.98	3.15						
	63 (17.2)	31.23	24.39	1.93	29.25	23.60	2.12	27.17	22.77	2.34	25.00	21.89	2.58	22.78	20.92	2.86	20.60	20.60	3.17						
	62 (16.7)	31.80	31.80	1.93	30.09	30.09	2.12	28.26	28.26	2.33	26.32	26.32	2.57	24.24	24.24	2.85	21.96	21.96	3.15						
	57 (13.9)	31.76	31.76	1.93	30.05	30.05	2.12	28.22	28.22	2.33	26.29	26.29	2.57	24.21	24.21	2.85	21.94	21.94	3.15						

Evaporator Air		CONDENSER ENTERING AIR TEMPERATURES °F (°C)																							
CFM	EWB °F (°C)	75 (23.9)				85 (29.4)				95 (35)				105 (40.6)				115 (46.1)				125 (51.7)			
		Capacity MBtu/h†		Total System KW**	Capacity MBtu/h†		Total System KW**	Capacity MBtu/h†		Total System KW**	Capacity MBtu/h†		Total System KW**	Capacity MBtu/h†		Total System KW**	Capacity MBtu/h†		Total System KW**						
		Total	Sens†		Total	Sens†		Total	Sens†		Total	Sens†		Total	Sens†		Total	Sens†							
<b>NH4H436AKA1* Outdoor Section With FMA4X36**A* Indoor Section</b>																									
1050	72 (22.2)	41.22	20.81	2.31	39.23	20.08	2.55	37.15	19.33	2.83	34.92	18.53	3.13	32.56	17.71	3.48	30.04	16.84	3.88						
	67 (19.4)	37.36	25.73	2.29	35.55	25.00	2.53	33.64	24.24	2.80	31.63	23.45	3.11	29.48	22.63	3.46	27.20	21.76	3.86						
	63 (17.2)	34.58	24.71	2.27	32.91	23.98	2.52	31.14	23.22	2.79	29.27	22.44	3.09	27.28	21.61	3.44	25.15	20.73	3.84						
	62 (16.7)	34.03	30.64	2.27	32.44	29.92	2.52	30.80	29.14	2.79	29.18	29.18	3.09	27.56	27.56	3.44	25.80	25.80	3.85						
	57 (13.9)	33.32	33.32	2.27	32.02	32.02	2.51	30.63	30.63	2.79	29.14	29.14	3.09	27.52	27.52	3.44	25.76	25.76	3.85						
1200	72 (22.2)	41.98	21.85	2.35	39.91	21.11	2.60	37.72	20.34	2.88	35.42	19.54	3.18	32.97	18.70	3.53	30.36	17.81	3.93						
	67 (19.4)	38.06	27.42	2.33	36.17	26.68	2.58	34.20	25.92	2.85	32.11	25.12	3.16	29.90	24.28	3.51	27.54	23.38	3.90						
	63 (17.2)	35.26	26.28	2.32	33.52	25.55	2.56	31.68	24.78	2.83	29.74	23.98	3.14	27.69	23.14	3.49	25.49	22.23	3.89						
	62 (16.7)	34.91	32.97	2.32	33.32	33.32	2.56	31.87	31.87	2.84	30.26	30.26	3.14	28.54	28.54	3.50	26.65	26.65	3.90						
	57 (13.9)	34.72	34.72	2.32	33.32	33.32	2.56	31.82	31.82	2.84	30.22	30.22	3.14	28.50	28.50	3.50	26.62	26.62	3.90						
1315	72 (22.2)	42.44	22.61	2.39	40.30	21.87	2.64	38.06	21.09	2.91	35.70	20.28	3.22	33.20	19.42	3.57	30.54	18.53	3.96						
	67 (19.4)	38.48	28.68	2.37	36.56	27.94	2.62	34.53	27.16	2.89	32.40	26.35	3.19	30.15	25.49	3.54	27.76	24.57	3.94						
	63 (17.2)	35.68	27.45	2.36	33.88	26.71	2.60	32.01	25.93	2.87	30.03	25.12	3.17	27.93	24.25	3.52	25.72	23.32	3.93						
	62 (16.7)	35.66	35.66	2.36	34.19	34.19	2.60	32.63	32.63	2.87	30.96	30.96	3.18	29.15	29.15	3.53	27.19	27.19	3.94						
	57 (13.9)	35.62	35.62	2.36	34.15	34.15	2.60	32.59	32.59	2.87	30.92	30.92	3.18	29.11	29.11	3.53	27.16	27.16	3.94						

See notes on pg. 11

Specifications subject to change without notice.

428 56 9702 02

## DETAILED COOLING CAPACITIES (CONT.)

428 56 9702 02

Specifications subject to change without notice.

Evaporator Air		CONDENSER ENTERING AIR TEMPERATURES °F (°C)																							
		75 (23.9)				85 (29.4)				95 (35)				105 (40.6)				115 (46.1)				125 (51.7)			
		CFM	EWB °F (°C)	Capacity MBtu/h†		Total System KW**	Capacity MBtu/h†		Total System KW**	Capacity MBtu/h†		Total System KW**	Capacity MBtu/h†		Total System KW**	Capacity MBtu/h†		Total System KW**	Capacity MBtu/h†		Total System KW**				
Total	Sens†			Total	Sens†		Total	Sens†		Total	Sens†		Total	Sens†		Total	Sens†								
<b>NH4H448AKA1* Outdoor Section With FEM4X48**BL Indoor Section</b>																									
1400	72 (22.2)	55.58	28.52	3.24	52.71	27.44	3.60	49.67	26.31	3.99	46.46	25.13	4.42	43.04	23.90	4.91	39.43	22.61	5.45						
	67 (19.4)	50.82	35.33	3.22	48.24	34.27	3.57	45.50	33.14	3.96	42.57	31.95	4.39	39.46	30.71	4.87	36.16	29.39	5.42						
	63 (17.2)	47.29	34.06	3.21	44.94	33.00	3.55	42.44	31.89	3.93	39.73	30.71	4.36	36.85	29.47	4.85	33.78	28.14	5.40						
	62 (16.7)	46.47	41.90	3.20	44.21	40.79	3.55	41.81	39.57	3.92	39.28	38.16	4.36	36.75	36.75	4.85	34.20	34.20	5.41						
	57 (13.9)	44.97	44.97	3.20	43.16	43.16	3.54	41.20	41.20	3.92	39.05	39.05	4.35	36.71	36.71	4.85	34.16	34.16	5.40						
1600	72 (22.2)	56.50	29.84	3.29	53.50	28.73	3.65	50.34	27.58	4.04	47.02	26.39	4.48	43.48	25.13	4.96	39.77	23.83	5.50						
	67 (19.4)	51.70	37.50	3.27	49.01	36.42	3.62	46.14	35.26	4.01	43.11	34.04	4.44	39.90	32.75	4.93	36.51	31.38	5.47						
	63 (17.2)	48.16	36.09	3.26	45.70	35.00	3.60	43.07	33.86	3.98	40.27	32.65	4.41	37.29	31.36	4.90	34.15	29.97	5.45						
	62 (16.7)	47.45	44.71	3.26	45.13	43.45	3.60	42.70	42.70	3.98	40.37	40.37	4.42	37.87	37.87	4.91	35.16	35.16	5.46						
	57 (13.9)	46.68	46.68	3.25	44.73	44.73	3.60	42.62	42.62	3.98	40.32	40.32	4.41	37.83	37.83	4.91	35.13	35.13	5.46						
1800	72 (22.2)	57.23	31.12	3.34	54.12	29.99	3.71	50.87	28.83	4.10	47.43	27.61	4.53	43.81	26.34	5.01	40.00	25.01	5.55						
	67 (19.4)	52.40	39.64	3.32	49.60	38.51	3.68	46.64	37.31	4.06	43.52	36.05	4.49	40.23	34.70	4.98	36.78	33.24	5.52						
	63 (17.2)	48.85	38.06	3.31	46.28	36.94	3.65	43.57	35.76	4.04	40.68	34.50	4.47	37.63	33.15	4.95	34.43	31.67	5.50						
	62 (16.7)	48.35	47.90	3.31	46.06	46.06	3.65	43.82	43.82	4.04	41.39	41.39	4.47	38.75	38.75	4.96	35.91	35.91	5.52						
	57 (13.9)	48.09	48.09	3.31	46.02	46.02	3.65	43.78	43.78	4.04	41.35	41.35	4.47	38.72	38.72	4.96	35.88	35.88	5.52						

Evaporator Air		CONDENSER ENTERING AIR TEMPERATURES °F (°C)																							
		75 (23.9)				85 (29.4)				95 (35)				105 (40.6)				115 (46.1)				125 (51.7)			
		CFM	EWB °F (°C)	Capacity MBtu/h†		Total System KW**	Capacity MBtu/h†		Total System KW**	Capacity MBtu/h†		Total System KW**	Capacity MBtu/h†		Total System KW**	Capacity MBtu/h†		Total System KW**	Capacity MBtu/h†		Total System KW**				
Total	Sens†			Total	Sens†		Total	Sens†		Total	Sens†		Total	Sens†		Total	Sens†								
<b>NH4H460AKA1* Outdoor Section With FXM4X60**AL Indoor Section</b>																									
1750	72 (22.2)	71.53	37.82	3.89	68.08	36.52	4.29	64.42	35.16	4.76	60.48	33.71	5.29	56.24	32.16	5.90	51.76	30.56	6.59						
	67 (19.4)	65.68	47.25	3.85	62.56	45.95	4.25	59.23	44.58	4.71	55.66	43.13	5.25	51.76	41.55	5.86	47.62	39.88	6.55						
	63 (17.2)	61.40	45.63	3.82	58.54	44.34	4.22	55.47	42.98	4.68	52.16	41.52	5.21	48.55	39.94	5.82	44.67	38.26	6.52						
	62 (16.7)	60.35	56.38	3.81	57.59	55.02	4.21	54.66	53.49	4.68	51.60	51.60	5.21	48.60	48.60	5.82	45.33	45.33	6.52						
	57 (13.9)	58.88	58.88	3.80	56.63	56.63	4.21	54.21	54.21	4.67	51.52	51.52	5.21	48.54	48.54	5.82	45.28	45.28	6.52						
2000	72 (22.2)	72.60	39.66	3.96	69.02	38.35	4.36	65.21	36.95	4.82	61.14	35.48	5.35	56.77	33.92	5.96	52.16	32.28	6.65						
	67 (19.4)	66.73	50.32	3.91	63.47	48.98	4.32	60.02	47.58	4.78	56.30	46.08	5.31	52.30	44.46	5.92	48.05	42.73	6.61						
	63 (17.2)	62.44	48.48	3.88	59.46	47.16	4.29	56.27	45.76	4.75	52.83	44.26	5.28	49.11	42.64	5.89	45.13	40.88	6.58						
	62 (16.7)	61.58	60.29	3.88	58.75	58.75	4.28	56.09	56.09	4.75	53.22	53.22	5.28	50.04	50.04	5.90	46.58	46.58	6.59						
	57 (13.9)	61.06	61.06	3.87	58.64	58.64	4.28	56.03	56.03	4.75	53.16	53.16	5.28	49.99	49.99	5.89	46.53	46.53	6.59						
2250	72 (22.2)	73.40	41.42	4.02	69.69	40.08	4.42	65.78	38.67	4.88	61.60	37.18	5.41	57.12	35.59	6.02	52.43	33.95	6.71						
	67 (19.4)	67.50	53.24	3.98	64.14	51.88	4.38	60.57	50.43	4.84	56.77	48.88	5.37	52.69	47.20	5.98	48.38	45.35	6.67						
	63 (17.2)	63.23	51.19	3.95	60.13	49.83	4.35	56.84	48.39	4.81	53.33	46.85	5.34	49.52	45.15	5.95	45.49	43.27	6.64						
	62 (16.7)	62.93	62.93	3.95	60.36	60.36	4.35	57.57	57.57	4.82	54.54	54.54	5.35	51.19	51.19	5.97	47.57	47.57	6.66						
	57 (13.9)	62.86	62.86	3.94	60.29	60.29	4.35	57.51	57.51	4.82	54.48	54.48	5.35	51.14	51.14	5.96	47.53	47.53	6.66						

† Total and sensible capacities are net capacities. Blower motor heat has been subtracted.

‡ Sensible capacities shown are based on 80°F (27°C) entering air at the indoor coil. For sensible capacities at other than 80°F (27°C), deduct 835 Btu/h (245 kW) per 1000 CFM (480 L/S) of indoor coil air for each degree below 80°F (27°C), or add 835 Btu/h (245 kW) per 1000 CFM (480 L/S) of indoor coil air per degree above 80°F (27°C).

\*\* System kw is total of indoor and outdoor unit kilowatts.

EWB — Entering Wet Bulb

**NOTES:**

- Detailed cooling capacities are based on indoor and outdoor unit at the same elevation per AHRI standard 210/240–2008. If additional tubing length and/or indoor unit is located above outdoor unit, a slight variation in capacity may occur.
- When the required data falls between the published data, interpolation may be performed. Extrapolation is not an acceptable practice.

# HEAT PUMP HEATING PERFORMANCE

12

INDOOR AIR		OUTDOOR COIL ENTERING AIR TEMPERATURES °F (°C)																															
		-3 (-19.4)				7 (-13.9)				17 (-8.3)				27 (-2.8)				37 (2.8)				47 (8.3)				57 (13.9)				67 (19.4)			
		EDB °F (°C)	CFM	Capacity MBtuh		Total Sys. KW†	Capacity MBtuh		Total Sys. KW†	Capacity MBtuh		Total Sys. KW†	Capacity MBtuh		Total Sys. KW†	Capacity MBtuh		Total Sys. KW†	Capacity MBtuh		Total Sys. KW†	Capacity MBtuh		Total Sys. KW†	Capacity MBtuh		Total Sys. KW†	Capacity MBtuh		Total Sys. KW†			
Total	Integ*			Total	Integ*		Total	Integ*		Total	Integ*		Total	Integ*		Total	Integ*		Total	Integ*		Total	Integ*		Total	Integ*		Total	Integ*		Total	Integ*	Total
<b>NH4H418AKA1* Outdoor Section With FMA4X18**A* Indoor Section</b>																																	
65 (18.3)	525	5.18	4.77	1.03	7.27	6.68	1.08	9.73	8.87	1.13	11.98	10.64	1.18	14.44	13.14	1.23	17.27	17.27	1.29	20.50	20.50	1.38	24.08	24.08	1.47								
	600	5.26	4.84	1.04	7.38	6.78	1.08	9.87	9.00	1.13	12.12	10.76	1.16	14.64	13.32	1.21	17.54	17.54	1.26	20.83	20.83	1.34	24.29	24.29	1.42								
	675	5.34	4.91	1.05	7.47	6.86	1.08	9.97	9.09	1.12	12.24	10.87	1.16	14.81	13.47	1.19	17.75	17.75	1.25	21.03	21.03	1.31	24.26	24.26	1.38								
70 (21.1)	525	4.94	4.54	1.08	7.03	6.46	1.13	9.27	8.45	1.18	11.76	10.45	1.24	14.17	12.90	1.29	16.94	16.94	1.35	20.10	20.10	1.44	23.70	23.70	1.55								
	600	5.02	4.62	1.09	7.14	6.56	1.13	9.41	8.58	1.18	11.90	10.57	1.22	14.37	13.07	1.27	17.20	17.20	1.33	20.44	20.44	1.41	23.94	23.94	1.49								
	675	5.10	4.69	1.09	7.23	6.65	1.14	9.56	8.72	1.18	12.03	10.68	1.21	14.53	13.22	1.25	17.41	17.41	1.31	20.69	20.69	1.38	23.99	23.99	1.45								
75 (23.9)	525	4.66	4.29	1.13	6.76	6.21	1.19	8.98	8.19	1.24	11.55	10.25	1.30	13.90	12.65	1.35	16.61	16.61	1.42	19.71	19.71	1.51	23.29	23.29	1.63								
	600	4.75	4.37	1.14	6.87	6.31	1.19	9.12	8.32	1.23	11.68	10.37	1.28	14.09	12.82	1.33	16.86	16.86	1.39	20.04	20.04	1.47	23.56	23.56	1.56								
	675	4.83	4.45	1.14	6.96	6.40	1.19	9.24	8.43	1.23	11.80	10.48	1.27	14.25	12.97	1.32	17.07	17.07	1.37	20.30	20.30	1.45	23.68	23.68	1.52								

INDOOR AIR		OUTDOOR COIL ENTERING AIR TEMPERATURES °F (°C)																															
		-3 (-19.4)				7 (-13.9)				17 (-8.3)				27 (-2.8)				37 (2.8)				47 (8.3)				57 (13.9)				67 (19.4)			
		EDB °F (°C)	CFM	Capacity MBtuh		Total Sys. KW†	Capacity MBtuh		Total Sys. KW†	Capacity MBtuh		Total Sys. KW†	Capacity MBtuh		Total Sys. KW†	Capacity MBtuh		Total Sys. KW†	Capacity MBtuh		Total Sys. KW†	Capacity MBtuh		Total Sys. KW†	Capacity MBtuh		Total Sys. KW†	Capacity MBtuh		Total Sys. KW†			
Total	Integ*			Total	Integ*		Total	Integ*		Total	Integ*		Total	Integ*		Total	Integ*		Total	Integ*		Total	Integ*		Total	Integ*		Total	Integ*		Total	Integ*	Total
<b>NH4H424AKA1* Outdoor Section With FMA4X24**A* Indoor Section</b>																																	
65 (18.3)	700	8.00	7.36	1.42	10.61	9.75	1.49	13.33	12.15	1.54	16.75	14.88	1.60	19.86	18.07	1.64	23.17	23.17	1.70	27.16	27.16	1.79	31.89	31.89	1.92								
	800	8.15	7.50	1.43	10.79	9.91	1.50	13.54	12.35	1.54	16.99	15.09	1.59	20.12	18.31	1.62	23.49	23.49	1.67	27.57	27.57	1.75	32.41	32.41	1.87								
	900	8.30	7.63	1.44	10.95	10.07	1.51	13.73	12.52	1.55	17.19	15.27	1.59	20.35	18.51	1.61	23.76	23.76	1.65	27.90	27.90	1.73	32.81	32.81	1.84								
70 (21.1)	700	7.58	6.97	1.48	10.21	9.39	1.56	12.94	11.80	1.62	15.97	14.19	1.67	19.54	17.79	1.73	22.80	22.80	1.79	26.74	26.74	1.87	31.40	31.40	2.01								
	800	7.74	7.12	1.50	10.40	9.56	1.57	13.17	12.00	1.62	16.29	14.47	1.66	19.79	18.01	1.71	23.12	23.12	1.76	27.14	27.14	1.83	31.91	31.91	1.96								
	900	7.89	7.26	1.51	10.57	9.71	1.58	13.35	12.17	1.62	16.85	14.96	1.67	20.02	18.22	1.70	23.38	23.38	1.74	27.47	27.47	1.81	32.32	32.32	1.93								
75 (23.9)	700	7.14	6.57	1.55	9.78	8.99	1.63	12.54	11.44	1.69	15.52	13.78	1.75	19.22	17.49	1.82	22.44	22.44	1.88	26.31	26.31	1.97	30.89	30.89	2.10								
	800	7.30	6.72	1.57	9.98	9.17	1.64	12.76	11.64	1.69	15.79	14.02	1.74	19.46	17.71	1.80	22.74	22.74	1.85	26.70	26.70	1.92	31.40	31.40	2.05								
	900	7.44	6.85	1.58	10.14	9.32	1.65	12.96	11.81	1.70	16.03	14.23	1.74	19.68	17.91	1.79	23.00	23.00	1.83	27.03	27.03	1.90	31.81	31.81	2.02								

See notes on pg. 13

INDOOR AIR		OUTDOOR COIL ENTERING AIR TEMPERATURES °F (°C)																															
		-3 (-19.4)				7 (-13.9)				17 (-8.3)				27 (-2.8)				37 (2.8)				47 (8.3)				57 (13.9)				67 (19.4)			
		EDB °F (°C)	CFM	Capacity MBtuh		Total Sys. KW†	Capacity MBtuh		Total Sys. KW†	Capacity MBtuh		Total Sys. KW†	Capacity MBtuh		Total Sys. KW†	Capacity MBtuh		Total Sys. KW†	Capacity MBtuh		Total Sys. KW†	Capacity MBtuh		Total Sys. KW†	Capacity MBtuh		Total Sys. KW†	Capacity MBtuh		Total Sys. KW†			
Total	Integ*			Total	Integ*		Total	Integ*		Total	Integ*		Total	Integ*		Total	Integ*		Total	Integ*		Total	Integ*		Total	Integ*		Total	Integ*		Total	Integ*	Total
<b>NH4H430AKA1* Outdoor Section With FMA4X30**A* Indoor Section</b>																																	
65 (18.3)	875	8.71	8.01	1.63	12.19	11.20	1.70	15.84	14.45	1.77	19.79	17.58	1.84	24.22	22.04	1.93	28.29	28.29	1.99	32.79	32.79	2.07	37.67	37.67	2.16								
	1000	8.86	8.15	1.64	12.38	11.38	1.70	16.09	14.67	1.77	20.11	17.86	1.84	24.53	22.32	1.92	28.59	28.59	1.97	33.13	33.13	2.03	38.00	38.00	2.11								
	1125	9.02	8.30	1.66	12.59	11.57	1.71	16.33	14.89	1.77	20.85	18.52	1.85	24.79	22.56	1.91	28.83	28.83	1.95	33.38	33.38	2.01	38.22	38.22	2.08								
70 (21.1)	875	8.18	7.53	1.70	11.67	10.73	1.77	15.33	13.97	1.84	19.23	17.08	1.92	23.82	21.67	2.02	27.89	27.89	2.09	32.31	32.31	2.16	37.15	37.15	2.25								
	1000	8.35	7.68	1.72	11.89	10.93	1.78	15.59	14.21	1.85	19.56	17.37	1.92	24.13	21.95	2.00	28.20	28.20	2.06	32.66	32.66	2.12	37.51	37.51	2.20								
	1125	8.50	7.82	1.73	12.08	11.10	1.79	15.81	14.42	1.85	19.81	17.59	1.92	24.36	22.17	1.99	28.43	28.43	2.04	32.93	32.93	2.10	37.74	37.74	2.17								
75 (23.9)	875	7.61	7.00	1.78	11.12	10.22	1.85	14.77	13.47	1.92	18.64	16.56	2.00	23.39	21.29	2.11	27.47	27.47	2.18	31.84	31.84	2.26	36.63	36.63	2.35								
	1000	7.78	7.16	1.79	11.33	10.41	1.86	15.04	13.71	1.93	18.99	16.87	2.00	23.71	21.57	2.09	27.78	27.78	2.15	32.19	32.19	2.22	36.99	36.99	2.30								
	1125	7.94	7.30	1.81	11.50	10.57	1.87	15.27	13.92	1.93	19.25	17.10	2.00	23.97	21.81	2.08	28.04	28.04	2.13	32.46	32.46	2.19	37.24	37.24	2.27								

Specifications subject to change without notice.

428 56 9702 02

# HEAT PUMP HEATING PERFORMANCE (CONT.)

428 56 9702 02

INDOOR AIR		OUTDOOR COIL ENTERING AIR TEMPERATURES °F (°C)																															
EDB °F (°C)	CFM	-3 (-19.4)				7 (-13.9)				17 (-8.3)				27 (-2.8)				37 (2.8)				47 (8.3)				57 (13.9)				67 (19.4)			
		Capacity MBtuh		Total Sys. KW†	Capacity MBtuh		Total Sys. KW†	Capacity MBtuh		Total Sys. KW†	Capacity MBtuh		Total Sys. KW†	Capacity MBtuh		Total Sys. KW†	Capacity MBtuh		Total Sys. KW†	Capacity MBtuh		Total Sys. KW†	Capacity MBtuh		Total Sys. KW†	Capacity MBtuh		Total Sys. KW†					
		Total	Integ*		Total	Integ*		Total	Integ*		Total	Integ*		Total	Integ*		Total	Integ*		Total	Integ*		Total	Integ*		Total	Integ*						
<b>NH4H436AKA1* Outdoor Section With FMA4X36**A Indoor Section</b>																																	
65 (18.3)	1050	11.50	10.58	2.02	15.24	14.01	2.10	19.32	17.61	2.17	23.78	21.12	2.25	29.39	26.75	2.36	34.26	34.26	2.46	39.84	39.84	2.58	46.24	46.24	2.73								
	1200	11.74	10.80	2.04	15.54	14.28	2.11	19.67	17.93	2.18	24.19	21.49	2.25	29.82	27.13	2.35	34.76	34.76	2.43	40.49	40.49	2.54	47.07	47.07	2.68								
	1350	12.00	11.04	2.07	15.83	14.55	2.14	20.00	18.23	2.20	24.58	21.83	2.26	30.16	27.45	2.35	35.20	35.20	2.42	41.03	41.03	2.52	47.76	47.76	2.65								
70 (21.1)	1050	10.81	9.95	2.10	14.57	13.39	2.18	18.65	17.00	2.26	23.09	20.50	2.35	28.33	25.78	2.45	33.69	33.69	2.57	39.14	39.14	2.69	45.43	45.43	2.85								
	1200	11.10	10.21	2.13	14.90	13.69	2.20	19.03	17.35	2.28	23.53	20.89	2.35	29.28	26.64	2.45	34.20	34.20	2.54	39.79	39.79	2.65	46.23	46.23	2.80								
	1350	11.34	10.44	2.16	15.18	13.95	2.23	19.34	17.64	2.29	23.89	21.22	2.36	29.65	26.99	2.45	34.62	34.62	2.53	40.32	40.32	2.63	46.91	46.91	2.77								
75 (23.9)	1050	10.08	9.28	2.19	13.85	12.73	2.27	17.94	16.36	2.36	22.37	19.87	2.45	27.34	24.87	2.55	33.12	33.12	2.68	38.45	38.45	2.81	44.63	44.63	2.97								
	1200	10.36	9.53	2.21	14.18	13.03	2.29	18.33	16.71	2.37	22.82	20.26	2.45	27.93	25.41	2.54	33.62	33.62	2.66	39.07	39.07	2.77	45.41	45.41	2.92								
	1350	10.61	9.76	2.25	14.46	13.29	2.32	18.65	17.01	2.39	23.19	20.59	2.46	28.50	25.93	2.55	34.03	34.03	2.65	39.60	39.60	2.75	46.06	46.06	2.89								

See notes on pg. 13

INDOOR AIR		OUTDOOR COIL ENTERING AIR TEMPERATURES °F (°C)																															
EDB °F (°C)	CFM	-3 (-19.4)				7 (-13.9)				17 (-8.3)				27 (-2.8)				37 (2.8)				47 (8.3)				57 (13.9)				67 (19.4)			
		Capacity MBtuh		Total Sys. KW†	Capacity MBtuh		Total Sys. KW†	Capacity MBtuh		Total Sys. KW†	Capacity MBtuh		Total Sys. KW†	Capacity MBtuh		Total Sys. KW†	Capacity MBtuh		Total Sys. KW†	Capacity MBtuh		Total Sys. KW†	Capacity MBtuh		Total Sys. KW†	Capacity MBtuh		Total Sys. KW†					
		Total	Integ*		Total	Integ*		Total	Integ*		Total	Integ*		Total	Integ*		Total	Integ*		Total	Integ*		Total	Integ*		Total	Integ*						
<b>NH4H48AKA1* Outdoor Section With FEM4X48**BL Indoor Section</b>																																	
65 (18.3)	1400	16.21	14.91	2.77	21.31	19.58	2.89	26.72	24.37	3.01	32.57	28.93	3.14	39.84	36.26	3.33	46.71	46.71	3.52	54.10	54.10	3.71	62.59	62.59	3.93								
	1600	16.54	15.21	2.79	21.68	19.93	2.90	27.15	24.76	3.01	33.12	29.41	3.13	40.86	37.18	3.32	47.30	47.30	3.47	54.89	54.89	3.64	63.64	63.64	3.84								
	1800	16.82	15.47	2.82	22.01	20.22	2.92	27.53	25.10	3.02	33.58	29.82	3.13	41.31	37.59	3.30	47.82	47.82	3.44	55.54	55.54	3.59	64.50	64.50	3.78								
70 (21.1)	1400	15.43	14.20	2.87	20.52	18.85	3.00	25.92	23.63	3.13	31.70	28.15	3.27	38.39	34.93	3.45	46.00	46.00	3.68	53.26	53.26	3.87	61.59	61.59	4.11								
	1600	15.76	14.50	2.90	20.89	19.20	3.01	26.37	24.04	3.13	32.24	28.64	3.26	39.29	35.75	3.42	46.58	46.58	3.63	54.04	54.04	3.80	62.61	62.61	4.01								
	1800	16.04	14.76	2.93	21.23	19.51	3.03	26.75	24.39	3.14	32.71	29.05	3.26	40.44	36.80	3.44	47.10	47.10	3.60	54.68	54.68	3.75	63.45	63.45	3.95								
75 (23.9)	1400	14.58	13.42	2.98	19.66	18.06	3.11	25.08	22.86	3.26	30.81	27.37	3.41	37.32	33.96	3.59	45.27	45.27	3.85	52.45	52.45	4.04	60.60	60.60	4.28								
	1600	14.90	13.71	3.01	20.04	18.42	3.13	25.52	23.27	3.26	31.34	27.83	3.40	38.01	34.59	3.56	45.86	45.86	3.79	53.19	53.19	3.96	61.59	61.59	4.18								
	1800	15.19	13.98	3.04	20.38	18.73	3.15	25.91	23.63	3.27	31.80	28.25	3.40	38.63	35.15	3.55	46.37	46.37	3.76	53.82	53.82	3.91	62.41	62.41	4.12								

INDOOR AIR		OUTDOOR COIL ENTERING AIR TEMPERATURES °F (°C)																															
EDB °F (°C)	CFM	-3 (-19.4)				7 (-13.9)				17 (-8.3)				27 (-2.8)				37 (2.8)				47 (8.3)				57 (13.9)				67 (19.4)			
		Capacity MBtuh		Total Sys. KW†	Capacity MBtuh		Total Sys. KW†	Capacity MBtuh		Total Sys. KW†	Capacity MBtuh		Total Sys. KW†	Capacity MBtuh		Total Sys. KW†	Capacity MBtuh		Total Sys. KW†	Capacity MBtuh		Total Sys. KW†	Capacity MBtuh		Total Sys. KW†	Capacity MBtuh		Total Sys. KW†					
		Total	Integ*		Total	Integ*		Total	Integ*		Total	Integ*		Total	Integ*		Total	Integ*		Total	Integ*		Total	Integ*		Total	Integ*						
<b>NH4H460AKA1* Outdoor Section With FXM4X60**AL Indoor Section</b>																																	
65 (18.3)	1750	22.65	20.84	3.14	28.50	26.19	3.26	34.87	31.79	3.38	43.02	38.21	3.56	50.31	45.79	3.71	58.30	58.30	3.87	67.89	67.89	4.03	77.66	77.66	4.20								
	2000	23.00	21.16	3.16	28.89	26.54	3.27	35.32	32.20	3.38	43.42	38.56	3.54	50.81	46.24	3.67	58.96	58.96	3.82	68.49	68.49	3.95	77.97	77.97	4.10								
	2250	23.32	21.46	3.19	29.23	26.86	3.28	35.73	32.57	3.39	43.80	38.91	3.53	51.25	46.64	3.65	59.50	59.50	3.80	68.88	68.88	3.91	78.00	78.00	4.04								
70 (21.1)	1750	21.90	20.15	3.28	27.79	25.53	3.41	34.12	31.11	3.54	42.54	37.78	3.73	49.72	45.25	3.88	57.58	57.58	4.04	67.08	67.08	4.22	76.80	76.80	4.39								
	2000	22.26	20.48	3.31	28.18	25.90	3.42	34.59	31.54	3.53	42.97	38.16	3.71	50.22	45.70	3.84	58.23	58.23	4.00	67.73	67.73	4.13	77.14	77.14	4.29								
	2250	22.58	20.77	3.34	28.54	26.23	3.44	34.98	31.90	3.55	43.31	38.47	3.70	50.65	46.10	3.83	58.78	58.78	3.97	68.13	68.13	4.09	77.22	77.22	4.23								
75 (23.9)	1750	21.09	19.41	3.43	27.02	24.83	3.56	33.36	30.41	3.70	41.01	36.42	3.87	49.13	44.71	4.07	56.88	56.88	4.23	66.27	66.27	4.41	75.91	75.91	4.60								
	2000	21.45	19.74	3.45	27.43	25.21	3.57	33.81	30.82	3.69	42.41	37.66	3.88	49.60	45.14	4.02	57.51	57.51	4.18	66.93	66.93	4.32	76.30	76.30	4.49								
	2250	21.77	20.03	3.48	27.79	25.54	3.59	34.21	31.19	3.71	42.80	38.01	3.88	50.04	45.53	4.01	58.06	58.06	4.15	67.38	67.38	4.27	76.42	76.42	4.42								

\* The Btuh heating capacity values shown are net integrated values from which the defrost effect has been subtracted. The Btuh heating from supplement heaters should be added to those values to obtain total system capacity.

† The kW values include the compressor, outdoor fan motor, and indoor blower motor. The kW from supplement heaters should be added to these values to obtain total system kilowatts.

**NOTE:** When the required data falls between the published data, interpolation may be performed. Extrapolation is not an acceptable practice.

**EDB** — Entering Dry Bulb

## GUIDE SPECIFICATIONS GENERAL

### System Description

Outdoor-mounted, air-cooled, split-system heat pump unit suitable for ground or rooftop installation. Unit consists of a scroll-type hermetic compressor, an air-cooled coil, propeller-type condenser fan, and a control box. Unit will discharge supply air horizontally as shown on contract drawings. Unit will be used in a refrigeration circuit to match up to a packaged fan coil or furnace.

### Quality Assurance

- Unit will be rated in accordance with the latest edition of AHRI Standard 210.
- Unit will be certified for capacity and efficiency, and listed in the latest AHRI directory.
- Unit construction will comply with latest edition of ANSI/ASHRAE and with NEC.
- Unit will be constructed in accordance with UL

## PRODUCTS

### Equipment

- Factory assembled, single piece, air-cooled heat pump unit. Contained within the unit enclosure is all factory wiring, piping, controls, compressor, refrigerant charge R-410A, and special features required prior to field start-up.

### Unit Cabinet

- Unit cabinet will be constructed of galvanized steel and bonderized.

### Fans

- Condenser fan will be direct-drive propeller type, discharging air horizontally.

### AIR-COOLED, SPLIT-SYSTEM HEAT PUMP

#### 1-1/2 TO 5 NOMINAL TONS

- Condenser fan motors will be totally enclosed, 1-phase type with class B insulation and permanently lubricated bearings. Shafts will be corrosion resistant.
- Fan blades will be statically and dynamically balanced.
- Condenser fan openings will be equipped with coated steel wire safety guards.

### Compressor

- Compressor will be a scroll-type, hermetically sealed.
- Compressor will be mounted on rubber vibration isolators.

### Condenser Coil

- Condenser coil will be air cooled.
- Coil will be constructed of aluminum fins mechanically bonded to copper tubes which are then cleaned, dehydrated, and sealed.

### Refrigeration Components

- Refrigeration circuit components will include liquid-line front-seating shutoff valve with sweat connections, vapor-line front-seating shutoff valve with sweat connections, system charge of R-410A refrigerant, and compressor oil.
- Unit will be equipped with high-pressure switch, low pressure switch and filter drier for R-410A refrigerant.

standards and will carry the UL label of approval. Unit will have c-UL approval.

- Unit cabinet will be capable of withstanding Federal Test Method Standard No. 141 (Method 6061) 500-hr salt spray test.
- Air-cooled condenser coils will be leak tested and pressure tested
- Unit constructed in ISO9001 approved facility.

### Delivery, Storage, and Handling

- Unit will be shipped as single package only and is stored and handled per unit manufacturer's recommendations.

### Warranty (for inclusion by specifying engineer)

- U.S. and Canada only.

### Operating Characteristics

- The capacity of the unit will meet or exceed \_\_\_\_\_ Btuh at a suction temperature of \_\_\_\_\_ °F/°C. The power consumption at full load will not exceed \_\_\_\_\_ kW.
- Combination of the unit and the evaporator or fan coil unit will have a total net cooling capacity of \_\_\_\_\_ Btuh or greater at conditions of \_\_\_\_\_ CFM entering air temperature at the evaporator at \_\_\_\_\_ °F/°C wet bulb and \_\_\_\_\_ °F/°C dry bulb, and air entering the unit at \_\_\_\_\_ °F/°C.
- The system will have a SEER of \_\_\_\_\_ Btuh/watt or greater at DOE conditions.

### Electrical Requirements

- Nominal unit electrical characteristics will be \_\_\_\_\_ v, single phase, 60 hz. The unit will be capable of satisfactory operation within voltage limits of \_\_\_\_\_ v to \_\_\_\_\_ v.
- Nominal unit electrical characteristics will be \_\_\_\_\_ v, three phase, 60 hz. The unit will be capable of satisfactory operation within voltage limits of \_\_\_\_\_ v to \_\_\_\_\_ v.
- Unit electrical power will be single point connection.
- Control circuit will be 24v.

### Special Features

- Refer to section of this literature identifying accessories and descriptions for specific features and available enhancements.

**Accessory Description and Usage (Listed Alphabetically)**

**1. Ball-Bearing Fan Motor**

A fan motor with ball bearings which permits speed reduction while maintaining bearing lubrication.

**2. Compressor Start Assist – Capacitor and Relay**

Start capacitor and relay gives a "hard" boost to compressor motor at each start up.

Usage Guideline:

Required for reciprocating compressors in the following applications:

- Long line
- Low ambient cooling
- Hard shut off expansion valve on indoor coil
- Liquid line solenoid on indoor coil

Required for single-phase scroll compressors in the following applications:

- Long line
- Low ambient cooling

Suggested for all compressors in areas with a history of low voltage problems.

**3. Crankcase Heater**

An electric resistance heater which mounts to the base of the compressor to keep the lubricant warm during off cycles. Improves compressor lubrication on restart and minimizes the chance of liquid slugging.

Usage Guideline:

- Required in low ambient cooling applications.
- Required in long line applications.
- Suggested in all commercial applications.

**4. Evaporator Freeze Thermostat**

An SPST temperature-actuated switch that stops unit operation when evaporator reaches freeze-up conditions.

Usage Guideline:

Required when low ambient kit has been added.

**5. Isolation Relay**

An SPDT relay that switches the low-ambient controller out for the outdoor fan motor circuit when the heat pump switches to heating mode.

Usage Guideline:

Required on all heat pumps where low-ambient kit has been added.

**6. Liquid-Line Solenoid Valve (LLS)**

An electrically operated shutoff valve which stops and starts refrigerant liquid flow in response to compressor operation. It is to be installed at the outdoor unit to control refrigerant off cycle migration in the heating mode.

Usage Guideline:

An LLS is required in all long line heat pump applications to control refrigerant off cycle migration in the heating mode. See Long Line Guideline.

**7. Low Pressure Switch Kit**

Factory Installed added compressor protection against loss of refrigerant. It cuts out the system at 50 PSI and allows operation again at 95 PSI. Used for commercial or "harsh" environment applications for extra protection.

**8. Time Delay Relay**

Optional accessory for systems that do not have an integral blower time delay.

**ACCESSORY USAGE GUIDELINE**

Accessory	REQUIRED FOR LOW-AMBIENT COOLING APPLICATIONS (Below 55°F / 12.8°C)	REQUIRED FOR LONG LINE APPLICATIONS* (Over 80 ft. / 24.38 m)	REQUIRED FOR SEA COAST APPLICATIONS (Within 2 miles / 3.22 km)
Ball Bearing Fan Motor	Standard	Standard	Standard
Compressor Start Assist Capacitor and Relay	Yes	Yes	No
Crankcase Heater	Yes	Yes	No
Evaporator Freeze Thermostat	Yes	No	No
Isolation Relay	Yes	No	No
Liquid Line Solenoid Valve	No	See Long-Line Application Guideline	No

\* For tubing line sets between 80 and 200 ft. (24.38 and 60.96 m) and/or 20 ft. (6.09 m) vertical differential, refer to Residential Split-System Longline Application Guideline.

**ACCESSORIES**

KIT NUMBER	KIT NAME	Unit Size (Voltage/Series)											
		018 AKA	024 AKA	030 AKA	036 AKA	036 AHA	036 ALA	048 AKA	048 AHA	048 ALA	060 AKA	060 AHA	060 ALA
NASA00601CH	Crankcase Heater	X	X	S	S	S	S						
NASA00501CH	Crankcase Heater							X	X		X	X	
NASA00301CH	Crankcase Heater									X			X
NASA001SC	PTC Start Assist	X	X	X	X			X			X		
NASA00201FS	Evaporator Freeze Stat	X	X	X	X	X	X	X	X	X	X	X	X
NASA001TD	Time Delay Relay	X	X	X	X	X	X	X	X	X	X	X	X
NASA00101IK	Isolation Relay	X	X	X	X	X	X	X	X	X	X	X	X
NASA401LA	Low Ambient Kit	X	X	X	X	X	X	X	X	X	X	X	X
NASA00101WB	Wind Baffle	X											
NASA00201WB	Wind Baffle		X										
NASA00301WB	Wind Baffle			X	X	X	X						
NASA00401WB	Wind Baffle							X	X	X	X	X	X
NASA00101WM	Wall Mounting Kit	X	X										
NASA00201WM	Wall Mounting Kit			X	X	X	X	X	X	X	X	X	X
NASA00201SJ	Sound Blanket Kit	X	X	X	X	X	X						
NASA00101SJ	Sound Blanket Kit							X	X	X	X	X	X
NASA001LS	Solenoid Valve Kit	X	X	X	X	X	X	X	X	X	X	X	X
NASA003SC	Capacitor Relay Start Assist	X	X	X	X			X			X		
NASA001AC	Cycle Protector	X	X	X	X	X	X	X	X	X	X	X	X

X = Accessory  
S = Standard