



Heating and Air Conditioning

TECHNICAL GUIDE

**R-410A
SPLIT-SYSTEM
AIR-COOLED CONDENSING UNITS
AND AIR HANDLERS**

PREDATOR® SERIES

**YC090-240 and YD120-240
CONDENSING UNIT MODELS**

**PC090-240 and PD180-240
HEAT PUMP UNIT MODELS**

**NC090-240 and ND120-240
AIR HANDLING UNIT MODELS**

**7.5 - 20 Ton
60 Hertz**

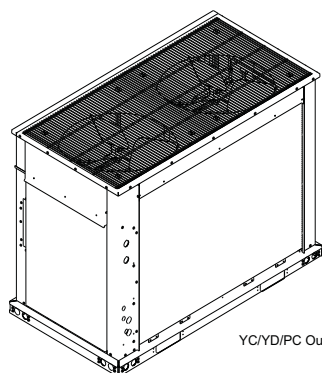

YC/YD/PC Outdoor Unit

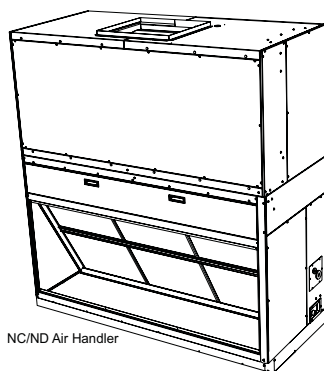

NC/ND Air Handler

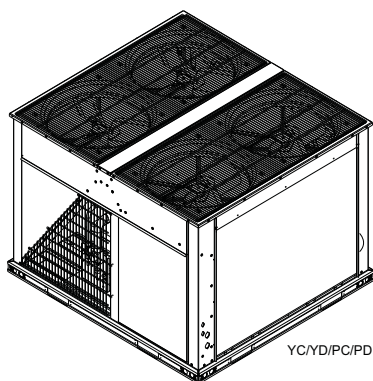

YC/YD/PC/PD Outdoor Unit

Description

Predator® condensing units and heat pumps are completely assembled, piped and wired at the factory to provide a single-piece unit for shipment and rigging. Each unit is pressurized with a holding charge of refrigerant R-410A for storage and/or shipping.

The compact design, clean styling, small footprint, and quiet operation make these condensing units and heat pumps suitable for almost any outdoor location. On rooftops... because they weigh much less than a single package unit of similar capacity and are much easier to rig and support. On the ground... because the footprint is compact allowing a variety of applications.

Both the Predator® condensing units and heat pumps are equipped with reliable Simplicity® microprocessor controls to assure proper operation and unit protection for long product life. Products from 10 to 20 tons are available in single or dual (2 or 4 pipe) refrigerant circuits for redundancy in operation and various application choices such as one outdoor unit matched with two indoor units.

The Predator® air handling units are completely assembled units, including a well-insulated cabinet, a DX cooling coil with copper tubing, aluminum fins, expansion valve(s), distributor(s), 2" throwaway filters, a centrifugal blower, a blower motor, an adjustable belt drive, a blower motor contactor and a small holding charge of refrigerant R-410A.

Units are shipped in the vertical position ready for field installation, but can be easily converted to horizontal position. An added benefit of the Predator® air handling units is they are designed to operate with either a condensing unit or a heat pump and no field modification or special unit is required for heat pump applications.



ISO 9001
Certified Quality
Management System

Nomenclature

Configured Split Condenser Model Number Nomenclature

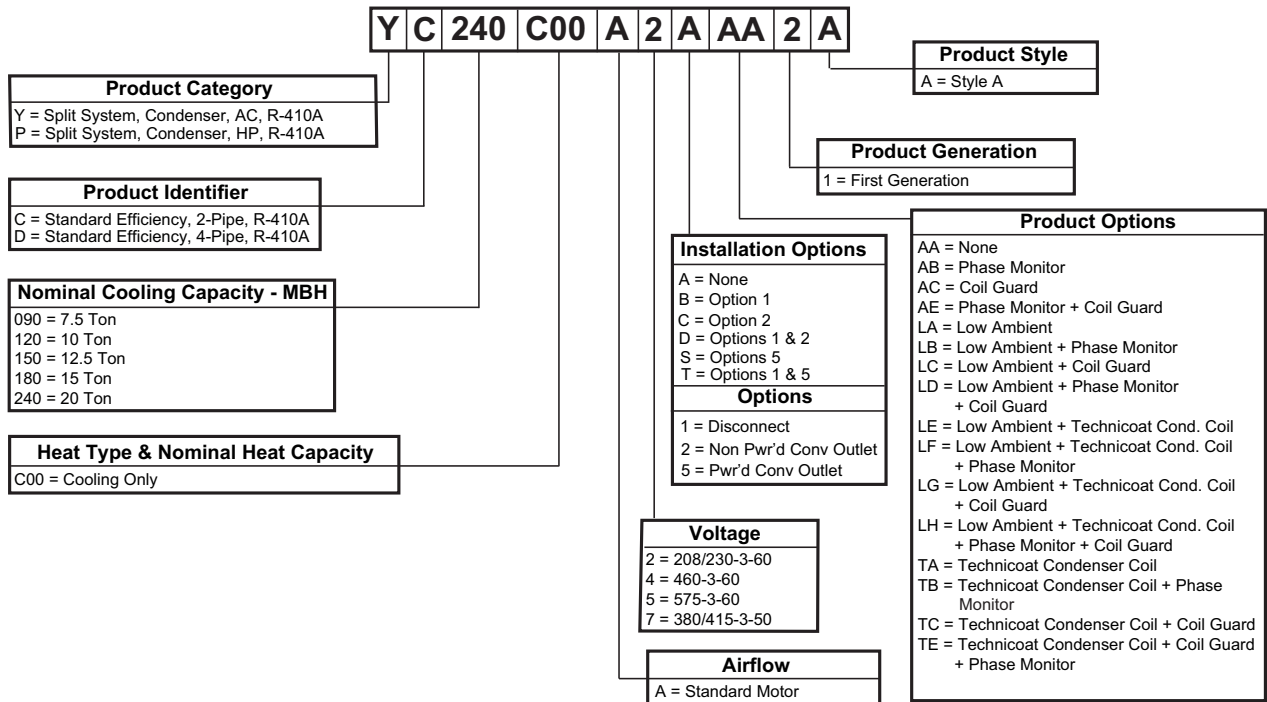

Configured Split Air Handler Model Number Nomenclature

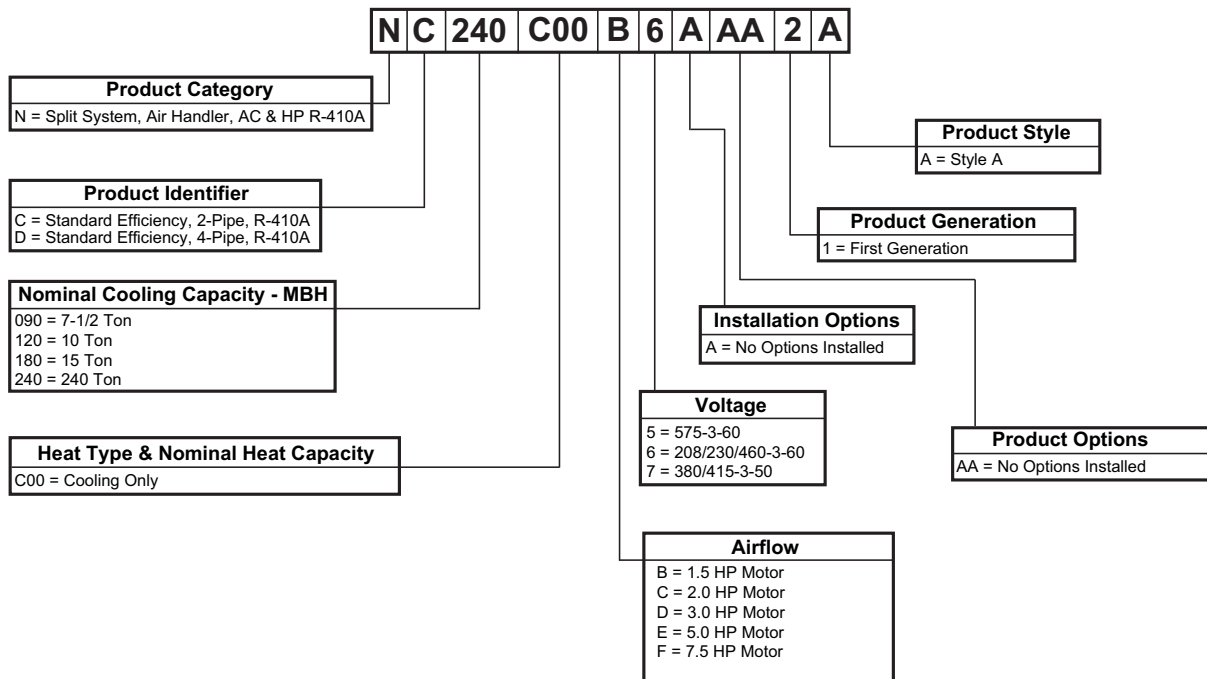

Condensing Unit Features and Benefits

Features

- Meets or exceeds ASHRAE 90.1 standards.
- Scroll compressors provide both high efficiency and reliability.
- Simplicity® Controls
- Dual refrigerant circuits on PD and YD models.
- Condensing unit coils are constructed of reliable and durable Micro-Channel aluminum tube and fins for long lasting, efficient operation. Micro-Channel technology provides exceptional durability along with reduced product weight and less refrigerant charge. Heat pumps units are equipped with aluminum fin, copper tube coils providing durability, reliability and value.
- Multiple condensing unit and air handler match-ups provide a wide range of application choices from oversized indoor motors to dual indoor units matched-up with single outdoor units.
- Crankcase heaters that will be de-energized when compressors are operating.
- Both high and low pressure controls. Since these controls are self-contained, there are no capillary lines to be damaged.
- Internal compressor motor protection.
- Class 2, 24-volt thermostat control circuit protected by a re-settable breaker.
- Standard factory installed service valves.
- Filter-driers are shipped in the unit's control box for field installation in the liquid line leaving the outdoor unit.
- Copper stub-outs are factory mounted on the suction and liquid lines to simplify the field piping connections.
- Simplicity® Controls provide stable cooling operation at ambient temperatures down to 40°F with low ambient kits available for operation to 0°F.
- Capacity staging for more economical operation and stable temperature levels within the conditioned space.
- Simplicity® Controls prevent the unit from cycling on safety control with "Three Outs" technology preventing nuisance trips, but protecting the equipment when valid operational issues are experienced.
- Simplicity® Controls monitor each safety independently (High pressure, low pressure, low voltage) allowing ease of troubleshooting if any problems arise.
- Inherently protected condenser fan motors.
- Technicoated outdoor coils for sea coast or corrosive environment applications.
- Factory installed disconnect to allow power to be removed from the unit when performing periodic maintenance or for service.

- Factory installed powered or non-powered 115 volt GFI outlet.
- Factory installed phase monitor to protect the unit from phase loss or phase reversal.

Benefits

The Predator® condensing units and heat pumps can be applied on a rooftop or at ground level... due to their ample sub-cooling capacity which allows them to be located three or more stories below the evaporator coil.

After assembly, the unit is pressurized with a combination of Refrigerant R-410A and nitrogen for pressure testing and additional leak testing. During this pressure test, the operation of the high pressure control is checked. As the unit is being evacuated and dehydrated, the operation of the low pressure control is also checked.

Every compressor, condenser fan motor, crankcase heater, and electrical control circuit is checked to assure a trouble-free start-up and years of reliable operation. The condenser fan guards are vinyl-coated to provide additional rust protection and to enhance the appearance of the unit. Compressors are mounted on rubber isolators to reduce the transmission of vibration. Vertical discharge condenser fans direct sound upward and away from any surrounding structures.

All sheet metal parts are constructed of commercial grade galvanized steel. After fabrication, each part is thoroughly cleaned to remove any grease or dirt from its surfaces. The external parts are coated with a powder paint to assure a quality finish for many years. This UL approved coating system has passed the 1000 hour, 20% salt spray test per ASTM Standard B117.

All condensing unit and heat pump models include a 5-year limited warranty on the compressor(s) and 1-year limited warranty on all other parts. The matching line of air handling units carries a 1-year limited parts warranty.

Outdoor Unit Accessories

Coil Guards: Wireform coil guards for added protection of outdoor coils. Designed to mount on each side of the product if required to provide protection from minor impacts or large debris.

Hail Guards: Hood type hail guards designed to protect the outdoor coils from hail. Can be installed on a single side or both to provide protection from storms that may produce hail.

Low Ambient Kits: Kits designed to allow the cooling only units to operate between 0°F and 40°F in the cooling mode. Standard cooling is allowed to 40°F. (Not designed for operation on heat pump units).

Guide Specifications

Split System Cooling Only Condensing Units Models: YC090-240, YD120-240 & Split System Heat Pump Models: PC090-240, PD180-240

General

- Factory assembled, single piece, air cooled condensing unit designed for outdoor installation.
- Factory wired, piped, and tested for leakage and functionality to assure trouble-free installation and start-up.
- Rated in accordance with ARI Standard 340/360.
- Manufactured in a facility registered under the ISO 9002 manufacturing quality standard.
- Designed and tested in accordance with ASHRAE 15 Safety Code for Mechanical Refrigeration and comply with NEC.
- Cooling performance rated in accordance with DOE and ARI test procedures.
- CSA listed and classified to UL 1995/CAN/CSA No. 236- M90 standards.
- One year limited parts warranty on complete unit with an additional four year compressor warranty.

Unit Operating Characteristics

Operating Range shall be between 125° F to 40° F in cooling as standard from factory.

- The capacity of the condensing unit shall meet or exceed _____ Btuh at a suction temperature of _____ F. The power consumption at full load shall not exceed _____ kW.
- The combination of the condensing unit and the evaporator or fan coil unit shall have a total net cooling capacity of _____ Btuh or greater at conditions of _____ cfm entering-air temperature at the evaporator at _____ F wet bulb and _____ F dry bulb, and air entering the condensing unit at _____ F.
- The system shall have an EER of _____ Btuh/ Watt or greater at standard ARI conditions.

Installer Shall

- Furnish York® air-cooled condensing units, heat pump or equivalent in accordance with the performance schedule shown on the plans, and
- Unit shall be stored and handled in accordance with unit manufacturer's instructions.
- Install each unit as shown on the plans in accordance with the manufacturer's recommendations and all applicable national and local codes

Unit Construction

- Constructed of zinc-coated, galvanized steel.
- Exterior surfaces bonded and coated with baked enamel finish by a powder paint process capable of withstanding a minimum of 1000 salt spray hours according to ASTM B117.
- Cabinet screws that comply with ASTM B117 salt spray test for a minimum of 750 hours.
- Permanently attached heavy-gage perimeter base rails with forklift slots and lifting holes.
- Removable access panels to all internal components.
- Separate access panel to controls.
- Access panels to allow outdoor coil cleaning.

Compressor(s)

- Hermetic scroll type, internally protected with high-pressure relief and over temperature protection.
- Two stage units operate in 50% capacity increments.
- Suction gas cooled
- Voltage range of $\pm 10\%$ of unit nameplate voltage.
- Neoprene isolators minimize sound transmission and vibration.
- Belly-band crankcase heaters keep refrigerant from diluting sump oil.
- Full charge of compressor oil

Outdoor Condenser Unit Coils

- Draw thru configuration
- Constructed with Micro-channel aluminum fins and aluminum tubing. All refrigerant tubing must share a common header.

Heat Pump Unit Outdoor Unit Coils

- Draw thru configuration
- Constructed with aluminum plate fins mechanically bonded to seamless internally enhanced copper tubes with all joints brazed.

Condenser Fans

- Direct driven propeller-type fans
- Statically and dynamically balanced
- Aluminum blades riveted to corrosion resistant steel spider brackets.
- Arranged for vertical air discharge.
- Equipped with PVC coated steel wire safety guards.

Condenser Motors

- Totally enclosed, air over cooled.
- Inherent overload protection.
- Permanently lubricated bearings.

- Must cycle to allow cooling operation down to 40°F.

Refrigerant Piping

- Solid core filter-drier(s) ship loose for field installation.
- Liquid and suction line service valves with gauge ports.
- Suction and discharge line service ports accessible from unit. Ports capped for leak prevention.
- Liquid line magnetic check valves
- Holding charge of R410A refrigerant.

Electrical Requirements

- Single-point connection electrical power.
- Nominal unit electrical characteristics shall be _____ v, 3-ph, 60 Hz. The unit shall be capable of satisfactory operation within voltage limits of _____ v to _____ v.
- Condenser fan motors and secondary of transformers shall be grounded.

Unit Controls

- All 24-volt control circuit, powered by a 24 volt transformer(s) and protected by a resettable breaker.
- Conventional thermostat must provide operation for both condensing units and heat pumps without an "O" output from the thermostat.
- Low voltage terminal strip for simple hook-up.
- Compressor motor protection shuts down unit for motor over-current, over-temperature or low voltage conditions.
- Safety lockouts provide reset capability at the space thermostat or base unit should any of the following standard safety devices trip and shut off compressor:
 - a. Loss-of-charge/Low-pressure switch.
 - b. High-pressure switch.
 - c. Control board diagnostics and fault code display.
 - d. Safety lockouts send a 24 volt signal to the control board's "X" terminal, allowing notification to the user via the thermostat fault light (if present).
 - e. Control board shall retain last 5 fault codes in non-volatile memory, which will not be lost in the event of a power loss. An LED (light-emitting diode) indicator flashes a fault code that indicates which safety switch has tripped.

Non-fused Disconnect Switch

- Factory-installed, internally mounted.
- Accessible from outside the unit.
- NEC and UL approved non-fused switch.
- Provides power off lockout capability.

Convenience Outlet

- Factory-installed, internally mounted.
- Accessible from outside the unit.
- 115V, 15 amp GFI receptacle with independent fuse protection.
- Required voltage provided by factory-installed step-down transformer or field supplied 115v circuit.

Low-ambient Head Pressure Control

- Standard operation down to 40 °F without a low ambient kit.
- Operation down to 0°F with a field-installed low ambient kit accessory. The controller modulates the fan motor speed in response to liquid line temperature or pressure.

Coil Guard

Factory or field installed decorative grille shall be placed on the units to protect condenser coil after installation.

Hail Guard Package

Field installed hail guard package shall protect coils against damage from hail and other flying debris.

Phenolic Coated Condenser Coils

Special phenolic coating available as a factory option on both outdoor and indoor coils.

Each Unit Shall Be:

- Covered by a 1-year limited parts warranty on the complete unit and 5-year on compressor(s).
- In current production with published literature available to check performance, limitations, specifications, power requirements, dimensions, operation and appearance.
- Indoor unit shall be equipped with a V-belt drive option that will permit the blower RPM to be adjusted to meet the CFM requirements of the air delivery system. (Refer to Technical Guide for Airflow Capabilities.)

Each Unit Enclosure Shall Have:

- Exterior panels of 18 gauge steel, finished with baked enamel to provide a long lasting quality appearance
- Removable panels to provide easy access to the internal components for maintenance and service on condensing units, heat pumps and air handlers
- Air handling units must have a filter rack that accepts both 2" and 4" filters.
- The dimensions of each unit shall not exceed those specified in the manufacture's literature.

- The minimum application clearances for condensing units, heat pumps and air handlers must meet those specified in the manufacturer's literature.

The Blower Motor Shall:

- Be mounted within the insulated cabinet to minimize the transmission of sound to the surrounding space, and any motor 7.5 HP or greater must have a service factor of 1.15.

The Evaporator Coil Shall:

- Consist of copper tubes arranged in staggered rows, mechanically expanded into aluminum fins,
- Be draw-through, and
- Include factory-mounted distributors, expansion valves and solenoid valves for capacity reduction.

The Blower Wheels Shall:

Be dynamically balanced to minimize the levels of sound and vibration generated by the unit.

Physical Data

YC090 - 240 and YD120 - 240 Physical Data

Component	Models									
	YC090	YC120	YD120	YC150	YD150	YC180	YD180	YC240	YD240	
Nominal Tonnage	7.5	10	10	12.5	12.5	15	15	20	20	
REFRIGERANT										
Refrigerant type	R-410A	R-410A	R-410A	R-410A	R-410A	R-410A	R-410A	R-410A	R-410A	
Holding charge (lb) ¹	1.0	1.0	1.0	1.0	1.0	1.0	1.0	1.0	1.0	
Operating Charge (lb) ²	System #1	4.7	6.5	3.3	9.6	4.8	10.8	5.4	12.8	6.4
	System #2	---	---	3.3	---	4.8	---	5.4	---	6.4
DIMENSIONS (inches)										
Length	59.1	59.1	59.1	59.1	59.1	59.1	59.1	59.1	59.1	
Width	31.9	31.9	31.9	31.9	31.9	64.1	64.1	64.1	64.1	
Height	44.5	50.0	50.0	50.0	50.0	44.5	44.5	50.0	50.0	
WEIGHTS (lb)										
Shipping	330	450	445	450	445	685	685	715	715	
Operating	325	445	440	445	440	675	675	710	710	
COMPRESSORS										
Type	Single Scroll	Tandem Scroll	Single Scroll	Tandem Scroll	Tandem Scroll	Tandem Scroll	Tandem Scroll	Tandem Scroll	Tandem Scroll	
Quantity	1	1	2	1	1	1	1	1	1	
Nominal Capacity (Tons)	System #1	7.5	10	5	12.5	6.3	15	7.5	10	
	System #2	---	---	5	---	6.3	---	7.5	10	
Capacity Stages	System #1	1	2	1	2	1	2	1	2	
	System #2	---	---	1	---	1	---	1	1	
SYSTEM DATA										
No. Refrigeration Circuits	1	1	2	1	2	1	2	1	2	
Suction Line OD (in.)	1 1/8	1 3/8	1 1/8	1 3/8	1 1/8	1 5/8	1 1/8	1 5/8	1 3/8	
Liquid Line OD (in.)	5/8	7/8	5/8	7/8	5/8	7/8	5/8	7/8	7/8	
OUTDOOR COIL DATA										
Face area (Sq. Ft.)	23.8	29.0	29.0	29.0	29.0	47.5	47.5	58.1	58.1	
Rows	1	1	1	1	1	1	1	1	1	
Fins per inch	23	23	23	23	23	23	23	23	23	
Tube diameter (in./MM)	0.71 / 18	0.71 / 18	0.71 / 18	0.71 / 18	0.71 / 18	0.71 / 18	0.71 / 18	0.71 / 18	0.71 / 18	
Circuitry Type	2-pass	2-pass	2-pass	2-pass	2-pass	2-pass	2-pass	2-pass	2-pass	
Refrigerant Control	---	---	---	---	---	---	---	---	---	
CONDENSER FAN DATA										
No. Fans / Diameter (in.)	2/24	2/24	2/24	4/24	4/24	4/24	4/24	4/24	4/24	
Type	Axial	Axial	Axial	Axial	Axial	Axial	Axial	Axial	Axial	
Drive type	Direct	Direct	Direct	Direct	Direct	Direct	Direct	Direct	Direct	
No. speeds	1	1	1	1	1	1	1	1	1	
Number of motors	System #1	2	2	2	2	4	2	4	2	
	System #2	---	---	---	---	---	2	---	2	
Motor HP (ea.)	1/3	3/4	3/4	3/4	3/4	1/3	1/3	3/4	3/4	
Rotation ³	CW	CW	CW	CW	CW	CW	CW	CW	CW	
RPM	850	850	1100	1100	1100	850	850	1100	1100	
Nominal CFM	System #1	7500	9800	9800	9800	9800	15000	7500	19600	9800
	System #2	---	---	---	---	---	---	7500	---	9800

¹ Holding Charge is the amount in the unit as shipped from the factory.

² Includes matched indoor blower unit but no piping.

³ When viewing the shaft end of the motor.

Unit Limitations

Condenser Unit limitations

Size (Tons)	Model	Unit Voltage	Applied Voltage ¹		Outdoor DB Temp Cooling (°F)		Indoor DB Temp Cooling (°F)		Outdoor DB Temp Heating (°F)		Indoor DB Temp Heating (°F)	
			Min	Max	Max	Min†	Max	Min	Max	Min	Max	Min
090 (7.5)	PC	208/230-3-60	187	252	125	40	86	68	70	0	80	50
		460-3-60	432	504								
		575-3-60	540	630								
090 (7.5)	YC	208/230-3-60	187	252	125	40	86	68	-	-	-	-
		460-3-60	432	504								
		575-3-60	540	630								
120 (10)	PC	208/230-3-60	187	252	125	40	86	68	70	0	80	50
		460-3-60	432	504								
		575-3-60	540	630								
120 (10)	YC/YD	208/230-3-60	187	252	125	40	86	68	-	-	-	-
		460-3-60	432	504								
		575-3-60	540	630								
150 (12.5)	YC/YD	208/230-3-60	187	252	125	40	86	68	-	-	-	-
		460-3-60	432	504								
		575-3-60	540	630								
180 (15)	PC/PD	208/230-3-60	187	252	125	40	86	68	70	0	80	50
		460-3-60	432	504								
		575-3-60	540	630								
180 (15)	YC/YD	208/230-3-60	187	252	125	40	86	68	-	-	-	-
		460-3-60	432	504								
		575-3-60	540	630								
240 (20)	PC/PD	208/230-3-60	187	252	125	40	86	68	70	0	80	50
		460-3-60	432	504								
		575-3-60	540	630								
240 (20)	YC/YD	208/230-3-60	187	252	125	40	86	68	-	-	-	-
		460-3-60	432	504								
		575-3-60	540	630								

1. Rated in accordance with ARI Standard 110, Range "A" Utilization Voltage.

†. Low Ambient accessories are available to permit stable system operation at ambient temperatures down to 0°F.

Cooling and Heating Ratings

Cooling And Heating Rating

Outdoor Unit	Condensing Unit Only			Indoor Unit	System Cooling Capacity ¹				Heating Capacity ¹				Rated Airflow (CFM)
	Gross Capacity ² (MBH)	KW	EER		Gross Capacity ³ (MBH)	EER	IEER	IPLV	High Outdoor		Low Outdoor		
									Gross Capacity ² (MBh)	COP	Gross Capacity ² (MBh)	COP	
PC120 ⁴	N/A	N/A	N/A	NC090	92	11.0	11.4	---	82	3.3	49	2.3	3000
PC120 ⁴	N/A	N/A	N/A	NC120	124	11.0	11.4	11.8	109	3.3	63	2.1	4000
PC180 ⁴	N/A	N/A	N/A	NC180	180	10.6	11.5	12.4	168	3.3	104	2.3	6000
PD180 ⁴	N/A	N/A	N/A	ND180	180	10.6	11.5	12.0	168	3.4	103	2.4	6000
PC240 ⁴	N/A	N/A	N/A	NC240	238	10.6	12.4	12.5	216	3.3	139	2.5	8000
PD240 ⁴	N/A	N/A	N/A	ND240	238	10.6	11.7	12.1	220	3.4	124	2.2	8000
YC090	85	6.8	12.4	NC090	94	11.2	13.0	---	N/A	N/A	N/A	N/A	3000
YC090	85	6.8	12.4	NC120	99	11.9	13.0	---	N/A	N/A	N/A	N/A	3000
YC120	110	9.3	11.9	NC120	124	11.4	12.5	12.9	N/A	N/A	N/A	N/A	4000
YD120	108	9.1	11.8	ND120	124	11.2	11.2	11.6	N/A	N/A	N/A	N/A	4000
YC150	133	11.6	11.5	NC180	150	11.0	13.3	13.8	N/A	N/A	N/A	N/A	5000
YD150	136	11.5	11.8	ND180	150	11.0	12.1	12.3	N/A	N/A	N/A	N/A	5000
YC180	160	13.4	12.0	NC180	181	11.2	12.2	12.5	N/A	N/A	N/A	N/A	6000
YC180	160	13.4	12.0	NC240	190	11.7	12.7	12.5	N/A	N/A	N/A	N/A	6000
YD180	166	12.3	13.4	ND180	181	11.2	11.6	12.4	N/A	N/A	N/A	N/A	6000
YD180	166	12.3	13.4	(2)NC090	187	11.2	--	--	N/A	N/A	N/A	N/A	6000
YD180	166	12.3	13.4	(2)NC120	187	11.2	--	--	N/A	N/A	N/A	N/A	6000
YD180	166	12.3	13.4	ND240	190	11.7	13.4	11.2	N/A	N/A	N/A	N/A	6000
YC240	233	17.5	13.2	NC240	242	11.3	13.6	13.1	N/A	N/A	N/A	N/A	8000
YD240	222	17.3	12.8	ND240	242	11.3	11.9	12.6	N/A	N/A	N/A	N/A	8000
YD240	222	17.3	12.8	(2)NC120	240	11.6	--	--	N/A	N/A	N/A	N/A	8000

¹ Certified in accordance with the Unitary Large Equipment certification program, which is based on ARI Standard 340/360.

² Condensing unit only ratings are at 45°F SST and 95°F entering-air temperature.

³ Gross capacity does not include heat added by blower motor. Refer to appropriate table for blower horsepower.

⁴ Heat Pumps designed for matched systems only.

LEGEND

EER = Energy Efficiency Ratio

ARI = Air Conditioning and Refrigeration Institute

IPLV = Integration Part-Load Value

IEER = Integrated Energy Efficiency Ratio

Capacity Performance

Condenser and Air Handling Cooling Capacities

YC090/NC090

Air on Evaporator Coil		Temperature of Air on Condenser Coil															
CFM	WB (°F)	Total Capacity ¹ (MBh)	Total Input (kW) ²	Sensible Capacity (MBh)						Total Capacity ¹ (MBh)	Total Input (kW) ²	Sensible Capacity (MBh)					
				Return Dry Bulb (°F)								Return Dry Bulb (°F)					
				90	85	80	75	70	65			90	85	80	75	70	65
				75°F						85°F							
2250	77	110.8	6.0	51.5	42.0	32.6	-	-	-	107.2	6.5	49.8	40.4	30.9	-	-	-
	72	103.3	5.7	66.5	57.0	47.6	38.1	-	-	99.9	6.3	64.9	55.4	46.0	36.5	-	-
	67	95.9	5.5	81.5	72.0	62.6	53.1	43.6	-	92.6	6.2	80.0	70.5	61.0	51.6	42.1	-
	62	88.0	5.4	88.0	86.3	76.8	67.3	57.8	48.3	84.8	6.1	84.8	83.9	74.5	65.0	55.5	46.1
	57	77.7	5.2	77.7	77.7	72.2	62.8	53.3	43.8	80.1	6.0	80.1	80.1	73.1	63.6	54.2	44.7
2625	77	114.0	6.0	56.3	45.6	34.8	-	-	-	110.2	6.5	54.6	44.0	33.3	-	-	-
	72	106.3	5.7	72.3	61.6	50.9	40.1	-	-	102.7	6.3	70.8	60.2	49.6	38.9	-	-
	67	98.7	5.4	88.4	77.6	66.9	56.2	45.5	-	95.2	6.2	87.1	76.4	65.8	55.2	44.5	-
	62	90.6	5.4	90.6	89.7	82.2	71.9	60.7	50.0	87.1	6.1	87.1	86.7	80.3	69.6	59.0	48.3
	57	79.9	5.2	79.9	79.9	77.2	67.3	55.8	45.0	82.3	6.0	82.3	82.3	78.8	68.2	57.5	46.9
3000	77	117.2	5.9	61.0	49.1	37.1	-	-	-	113.1	6.5	59.4	47.5	35.7	-	-	-
	72	109.3	5.7	78.1	66.2	54.2	42.2	-	-	105.4	6.4	76.8	65.0	53.1	41.3	-	-
	67	101.4	5.4	95.2	83.2	71.3	59.3	47.3	-	97.7	6.2	94.2	82.4	70.5	58.7	46.9	-
	62	93.1	5.4	93.1	93.1	87.5	76.5	63.6	51.6	89.5	6.1	89.5	89.5	86.1	74.2	62.4	50.6
	57	82.2	5.2	82.2	82.2	82.2	71.7	58.3	46.3	84.5	6.0	84.5	84.5	84.5	72.7	60.8	49.0
3375	72	109.2	5.8	83.0	70.2	57.3	44.4	-	-	105.4	6.4	81.6	68.8	56.0	43.2	-	-
	67	101.3	5.5	98.2	88.2	75.3	62.5	49.6	-	97.7	6.3	96.0	87.2	74.3	61.5	48.7	-
	62	93.0	5.5	93.0	93.0	90.2	77.8	64.5	51.6	89.5	6.2	89.5	89.5	87.8	75.0	62.1	49.3
	57	82.1	5.3	82.1	82.1	82.1	70.0	56.4	43.5	84.5	6.1	84.5	84.5	84.5	71.7	58.9	46.0
3750	72	109.1	5.9	87.9	74.2	60.4	46.6	-	-	105.5	6.5	86.5	72.6	58.8	45.0	-	-
	67	101.2	5.6	101.2	93.2	79.4	65.7	51.9	-	97.8	6.3	97.8	91.9	78.1	64.3	50.5	-
	62	92.9	5.6	92.9	92.9	92.9	79.1	65.3	51.6	89.5	6.2	89.5	89.5	89.5	75.7	61.9	48.1
	57	82.0	5.4	82.0	82.0	82.0	68.2	54.4	40.7	84.5	6.1	84.5	84.5	84.5	70.7	56.9	43.1
				95°F						105°F							
2250	77	103.7	6.9	48.1	38.7	29.2	-	-	-	99.2	8.0	47.5	38.1	28.6	-	-	-
	72	96.5	6.9	63.3	53.8	44.4	35.0	-	-	92.2	8.0	62.1	52.6	43.2	33.7	-	-
	67	89.4	6.9	78.4	69.0	59.5	50.1	40.7	-	85.2	8.0	76.6	67.2	57.7	48.3	38.8	-
	62	81.6	6.7	81.6	81.6	72.1	62.7	53.3	43.8	77.9	7.7	77.9	77.9	69.2	59.7	50.3	40.9
	57	82.5	6.7	82.5	82.5	74.0	64.5	55.1	45.7	78.8	7.8	78.8	78.8	70.0	60.5	51.1	41.6
2625	77	106.4	7.0	52.9	42.3	31.8	-	-	-	101.7	8.1	53.5	41.7	31.1	-	-	-
	72	99.0	7.0	69.4	58.8	48.2	37.7	-	-	94.5	8.1	68.1	57.5	46.9	36.3	-	-
	67	91.7	6.9	85.8	75.3	64.7	54.1	43.6	-	87.3	8.0	82.8	73.3	62.7	52.1	41.5	-
	62	83.7	6.8	83.7	83.7	78.4	67.3	57.2	46.7	79.9	7.8	79.9	79.9	75.2	64.4	54.0	43.4
	57	84.6	6.7	84.6	84.6	80.4	69.1	59.2	48.7	80.7	7.9	80.7	80.7	76.1	65.1	54.8	44.2
3000	77	109.0	7.1	57.7	46.0	34.3	-	-	-	104.1	8.1	59.4	45.4	33.6	-	-	-
	72	101.5	7.0	75.5	63.8	52.1	40.4	-	-	96.8	8.1	74.2	62.5	50.7	38.9	-	-
	67	94.0	7.0	93.3	81.5	69.8	58.1	46.4	-	89.4	8.1	89.0	79.5	67.8	56.0	44.3	-
	62	85.8	6.8	85.8	85.8	84.6	72.0	61.2	49.5	81.8	7.9	81.8	81.8	81.2	69.0	57.7	46.0
	57	86.8	6.8	86.8	86.8	86.8	73.6	63.4	51.7	82.7	7.9	82.7	82.7	82.1	69.6	58.6	46.9
3375	72	101.7	7.1	80.2	67.5	54.7	41.9	-	-	96.9	8.1	79.2	66.3	53.5	40.7	-	-
	67	94.2	7.0	93.8	86.1	73.3	60.5	47.7	-	89.5	8.1	89.4	83.7	71.5	58.7	45.8	-
	62	86.0	6.8	86.0	86.0	85.4	72.1	59.8	47.0	82.0	7.9	82.0	82.0	81.7	68.6	56.0	43.2
	57	86.9	6.8	86.9	86.9	86.9	73.4	61.4	48.6	82.8	7.9	82.8	82.8	82.6	69.3	56.9	44.1
3750	72	101.9	7.1	85.0	71.1	57.3	43.4	-	-	97.1	8.1	84.1	70.2	56.3	42.4	-	-
	67	94.3	7.0	94.3	90.7	76.8	62.9	49.1	-	89.7	8.1	89.7	87.9	75.3	61.4	47.4	-
	62	86.1	6.9	86.1	86.1	86.1	72.3	58.4	44.5	82.1	7.9	82.1	82.1	82.1	68.2	54.3	40.4
	57	87.1	6.9	87.1	87.1	87.1	73.2	59.4	45.5	83.0	7.9	83.0	83.0	83.0	69.1	55.2	41.2

YC090/NC090 (Continued)

Air on Evaporator Coil		Temperature of Air on Condenser Coil															
CFM	WB (°F)	Total Capacity ¹ (MBh)	Total Input (kW) ²	Sensible Capacity (MBh)						Total Capacity ¹ (MBh)	Total Input (kW) ²	Sensible Capacity (MBh)					
				Return Dry Bulb (°F)								Return Dry Bulb (°F)					
				90	85	80	75	70	65			90	85	80	75	70	65
				115°F						125°F							
2250	77	94.7	9.0	46.9	37.5	28.0	-	-	-	90.2	10.1	46.3	36.9	27.4	-	-	-
	72	87.8	9.1	60.9	51.4	42.0	32.5	-	-	83.4	10.2	59.7	50.2	40.8	31.3	-	-
	67	80.9	9.1	74.8	65.4	55.9	46.5	37.0	-	76.7	10.3	73.0	63.6	54.1	44.6	35.2	-
	62	74.3	8.8	74.3	74.3	66.2	56.8	47.3	37.9	70.6	9.9	70.6	70.6	63.3	53.8	44.3	34.9
	57	75.0	8.9	75.0	75.0	66.0	56.5	47.0	37.6	71.3	10.0	71.3	71.3	61.9	52.5	43.0	33.5
2625	77	97.0	9.1	54.0	41.1	30.5	-	-	-	92.3	10.1	54.6	40.5	29.8	-	-	-
	72	89.9	9.1	66.9	56.3	45.6	35.0	-	-	85.3	10.2	65.7	55.0	44.3	33.7	-	-
	67	82.8	9.2	79.8	71.4	60.8	50.2	39.5	-	78.4	10.3	76.8	69.5	58.9	48.2	37.5	-
	62	76.1	8.8	76.1	76.1	72.0	61.4	50.8	40.1	72.2	9.9	72.2	72.2	68.9	58.4	47.5	36.9
	57	76.8	9.0	76.8	76.8	71.7	61.1	50.5	39.8	72.9	10.1	72.9	72.9	67.4	57.1	46.1	35.4
3000	77	99.2	9.1	61.1	44.7	32.9	-	-	-	94.3	10.2	62.8	44.1	32.2	-	-	-
	72	92.0	9.2	72.9	61.1	49.3	37.5	-	-	87.2	10.3	71.7	59.8	47.9	36.1	-	-
	67	84.8	9.2	84.8	77.5	65.7	53.9	42.1	-	80.2	10.3	80.2	75.5	63.6	51.8	39.9	-
	62	77.8	8.9	77.8	77.8	77.8	66.0	54.2	42.4	73.8	9.9	73.8	73.8	73.8	63.0	50.7	38.8
	57	78.6	9.0	78.6	78.6	77.5	65.7	53.9	42.1	74.5	10.1	74.5	74.5	72.9	61.8	49.1	37.3
3375	72	92.2	9.2	78.1	65.2	52.3	39.4	-	-	87.4	10.2	77.0	64.1	51.2	38.2	-	-
	67	84.9	9.2	84.9	81.3	69.7	56.8	44.0	-	80.3	10.3	80.3	78.9	67.9	55.0	42.1	-
	62	78.0	8.9	78.0	78.0	78.0	65.1	52.2	39.3	74.0	9.9	74.0	74.0	74.0	61.5	48.4	35.4
	57	78.7	9.0	78.7	78.7	78.2	65.3	52.4	39.5	74.6	10.1	74.6	74.6	73.8	61.3	47.9	35.0
	3750	72	92.3	9.1	83.3	69.3	55.4	41.4	-	-	87.5	10.2	82.4	68.4	54.4	40.4	-
67		85.1	9.2	85.1	85.1	73.8	59.8	45.8	-	80.4	10.3	80.4	80.4	72.2	58.2	44.2	-
62		78.1	8.9	78.1	78.1	78.1	64.1	50.2	36.2	74.1	9.9	74.1	74.1	74.1	60.1	46.1	32.1
57		78.9	9.0	78.9	78.9	78.9	64.9	51.0	37.0	74.8	10.0	74.8	74.8	74.8	60.8	46.8	32.8

¹ These capacities are gross ratings. For net capacity, deduct air blower motor, MBh = 2.547 x HP. Refer to the appropriate Blower Performance Table for the HP of the supply air blower motor.

² These ratings include the condenser fan motors and the compressor motors but not the supply air blower motor.

YC090/NC120

Air on Evaporator Coil		Temperature of Air on Condenser Coil															
CFM	WB (°F)	Total Capacity ¹ (MBh)	Total Input (kW) ²	Sensible Capacity (MBh)						Total Capacity ¹ (MBh)	Total Input (kW) ²	Sensible Capacity (MBh)					
				Return Dry Bulb (°F)								Return Dry Bulb (°F)					
				90	85	80	75	70	65			90	85	80	75	70	65
		75°F							85°F								
2250	77	105.1	6.0	49.2	40.2	31.1	-	-	-	108.2	6.6	50.3	41.2	32.1	-	-	-
	72	100.1	5.8	63.3	54.2	45.1	36.0	-	-	101.4	6.5	63.6	54.6	45.5	36.4	-	-
	67	95.1	5.7	77.3	68.2	59.1	50.0	40.9	-	94.6	6.3	77.0	67.9	58.8	49.7	40.7	-
	62	87.9	5.6	87.9	80.9	71.8	62.7	53.7	44.6	87.7	6.2	87.7	80.9	71.8	62.7	53.7	44.6
	57	83.1	5.5	83.1	83.1	76.8	67.7	58.6	49.5	84.1	6.2	84.1	84.1	77.2	68.2	59.1	50.0
2625	77	109.8	6.0	53.6	43.4	33.2	-	-	-	112.0	6.7	54.5	44.3	34.1	-	-	-
	72	104.5	5.9	68.6	58.3	48.1	37.9	-	-	105.0	6.5	68.6	58.4	48.3	38.1	-	-
	67	99.3	5.7	83.5	73.3	63.1	52.9	42.6	-	97.9	6.4	82.8	72.6	62.4	52.2	42.1	-
	62	91.8	5.6	91.8	86.9	76.7	66.8	56.2	46.0	90.7	6.2	90.7	86.4	76.2	66.0	55.8	45.7
	57	86.7	5.6	86.7	86.7	82.0	72.3	61.5	51.3	87.1	6.2	87.1	87.1	82.0	71.8	61.6	51.4
3000	77	114.5	6.1	58.0	46.6	35.3	-	-	-	115.8	6.7	58.7	47.4	36.1	-	-	-
	72	109.0	5.9	73.9	62.5	51.2	39.8	-	-	108.5	6.6	73.6	62.3	51.1	39.8	-	-
	67	103.5	5.8	89.8	78.4	67.1	55.7	44.4	-	101.2	6.4	88.6	77.3	66.0	54.7	43.4	-
	62	95.7	5.7	95.7	92.9	81.5	70.8	58.8	47.5	93.8	6.3	93.8	91.9	80.6	69.3	58.0	46.7
	57	90.4	5.6	90.4	90.4	87.1	76.9	64.4	53.1	90.0	6.3	90.0	90.0	86.7	75.4	64.1	52.8
3375	72	110.2	6.0	77.6	65.3	53.1	40.8	-	-	110.3	6.6	77.7	65.4	53.2	40.9	-	-
	67	104.6	5.8	94.1	81.8	69.5	57.3	45.0	-	102.9	6.5	93.3	81.0	68.8	56.5	44.3	-
	62	96.7	5.7	96.7	95.3	84.5	72.6	60.0	47.7	95.3	6.3	95.3	94.4	84.0	71.7	59.5	47.2
	57	91.4	5.6	91.4	91.4	89.8	78.0	65.2	53.0	91.5	6.3	91.5	91.5	89.8	77.6	65.3	53.1
	72	111.4	6.0	81.3	68.1	54.9	41.8	-	-	112.1	6.6	81.7	68.5	55.3	42.1	-	-
3750	67	105.8	5.9	98.4	85.2	72.0	58.8	45.6	-	104.5	6.5	97.9	84.7	71.5	58.3	45.1	-
	62	97.8	5.7	97.8	97.8	87.5	74.3	61.1	47.9	96.8	6.4	96.8	96.8	87.3	74.1	60.9	47.7
	57	92.4	5.7	92.4	92.4	82.4	79.2	66.0	52.8	93.0	6.3	93.0	93.0	83.0	79.8	66.6	53.4
			95°F							105°F							
	2250	77	111.4	7.2	51.3	42.3	33.2	-	-	-	107.2	8.2	49.9	40.9	31.8	-	-
72		102.8	7.1	64.0	54.9	45.9	36.8	-	-	99.1	8.0	62.6	53.5	44.5	35.4	-	-
67		94.2	7.0	76.7	67.6	58.5	49.5	40.4	-	90.9	7.9	75.3	66.2	57.1	48.1	39.0	-
62		87.4	6.8	87.4	80.9	71.8	62.7	53.6	44.6	84.0	7.8	84.0	79.3	70.2	61.1	52.0	43.0
57		85.2	6.8	85.2	85.2	77.7	68.6	59.6	50.5	82.3	7.7	82.3	82.3	74.9	65.8	56.8	47.7
2625	77	114.2	7.3	55.3	45.2	35.0	-	-	-	110.2	8.3	53.9	43.8	33.6	-	-	-
	72	105.4	7.2	68.7	58.5	48.4	38.2	-	-	101.8	8.1	67.4	57.2	47.0	36.9	-	-
	67	96.6	7.0	82.1	71.9	61.8	51.6	41.5	-	93.4	8.0	80.8	70.6	60.5	50.3	40.1	-
	62	89.6	6.9	89.6	85.9	75.8	65.3	55.5	45.3	86.3	7.9	86.3	83.7	74.3	63.9	53.9	43.8
	57	87.4	6.8	87.4	87.4	82.0	71.3	61.7	51.6	84.6	7.8	84.6	84.6	79.3	68.8	58.9	48.8
3000	77	117.1	7.3	59.3	48.1	36.9	-	-	-	113.1	8.3	58.0	46.7	35.5	-	-	-
	72	108.0	7.2	73.4	62.2	50.9	39.7	-	-	104.5	8.2	72.1	60.9	49.6	38.4	-	-
	67	99.0	7.1	87.5	76.2	65.0	53.8	42.5	-	95.9	8.1	86.3	75.0	63.8	52.5	41.3	-
	62	91.9	6.9	91.9	91.0	79.7	67.9	57.3	46.0	88.6	7.9	88.6	88.2	78.3	66.8	55.8	44.6
	57	89.6	6.9	89.6	89.6	86.3	74.0	63.8	52.6	86.9	7.8	86.9	86.9	83.6	71.8	61.1	49.8
3375	72	110.4	7.2	77.7	65.5	53.3	41.1	-	-	106.7	8.2	76.4	64.2	52.0	39.7	-	-
	67	101.2	7.1	92.5	80.2	68.0	55.8	43.6	-	97.9	8.1	91.3	79.0	66.8	54.6	42.3	-
	62	93.9	7.0	93.9	93.4	83.4	70.9	59.0	46.8	90.5	8.0	90.5	90.3	82.0	69.7	57.6	45.3
	57	91.5	6.9	91.5	91.5	89.9	77.1	65.5	53.2	88.7	7.9	88.7	88.7	87.1	74.6	62.6	50.4
	72	112.8	7.3	82.1	68.9	55.7	42.4	-	-	108.9	8.3	80.8	67.6	54.3	41.1	-	-
3750	67	103.3	7.1	97.4	84.2	71.0	57.8	44.6	-	100.0	8.1	96.3	83.0	69.8	56.6	43.4	-
	62	95.9	7.0	95.9	95.9	87.1	73.9	60.7	47.5	92.4	8.0	92.4	92.4	85.8	72.5	59.3	46.1
	57	93.5	6.9	93.5	93.5	93.5	80.3	67.1	53.9	90.5	7.9	90.5	90.5	90.5	77.3	64.1	50.9

YC090/NC120 (Continued)

Air on Evaporator Coil		Temperature of Air on Condenser Coil															
CFM	WB (°F)	Total Capacity ¹ (MBh)	Total Input (kW) ²	Sensible Capacity (MBh)					Total Capacity ¹ (MBh)	Total Input (kW) ²	Sensible Capacity (MBh)						
				Return Dry Bulb (°F)							Return Dry Bulb (°F)						
				90	85	80	75	70			65	90	85	80	75	70	65
115°F										125°F							
2250	77	103.1	9.1	48.5	39.5	30.4	-	-	-	98.9	10.1	47.1	38.0	29.0	-	-	-
	72	95.4	9.0	61.2	52.1	43.1	34.0	-	-	91.6	9.9	59.8	50.7	41.7	32.6	-	-
	67	87.6	8.9	73.9	64.8	55.8	46.7	37.6	-	84.4	9.8	72.5	63.4	54.4	45.3	36.2	-
	62	80.6	8.7	80.6	77.7	68.6	59.5	50.4	41.4	77.2	9.7	77.2	76.0	67.0	57.9	48.8	39.8
	57	79.5	8.6	79.5	79.5	72.1	63.0	54.0	44.9	76.6	9.5	76.6	76.6	69.3	60.2	51.2	42.1
2625	77	106.1	9.2	52.6	42.4	32.2	-	-	-	102.1	10.2	51.2	41.0	30.8	-	-	-
	72	98.2	9.1	66.0	55.9	45.7	35.5	-	-	94.6	10.1	64.7	54.5	44.3	34.2	-	-
	67	90.3	9.0	79.5	69.3	59.1	49.0	38.8	-	87.1	9.9	78.2	68.0	57.8	47.7	37.5	-
	62	83.0	8.8	83.0	81.5	72.8	62.6	52.4	42.3	79.7	9.8	79.7	79.3	71.2	61.2	50.9	40.7
	57	81.8	8.7	81.8	81.8	76.5	66.3	56.2	46.0	79.0	9.6	79.0	79.0	73.7	63.8	53.4	43.2
3000	77	109.2	9.3	56.6	45.3	34.1	-	-	-	105.3	10.3	55.2	44.0	32.7	-	-	-
	72	101.0	9.2	70.8	59.6	48.3	37.0	-	-	97.5	10.2	69.5	58.3	47.0	35.7	-	-
	67	92.9	9.1	85.1	73.8	62.5	51.3	40.0	-	89.8	10.1	83.9	72.6	61.3	50.0	38.7	-
	62	85.4	8.9	85.4	85.4	76.9	65.7	54.4	43.1	82.2	10.0	82.2	82.2	75.5	64.5	53.0	41.7
	57	84.2	8.8	84.2	84.2	80.9	69.6	58.4	47.1	81.5	9.8	81.5	81.5	78.2	67.4	55.6	44.3
3375	72	103.1	9.2	75.2	62.9	50.7	38.4	-	-	99.4	10.2	73.9	61.6	49.3	37.1	-	-
	67	94.7	9.1	90.1	77.8	65.6	53.3	41.1	-	91.5	10.1	88.9	76.6	64.4	52.1	39.8	-
	62	87.1	9.0	87.1	87.1	80.7	68.4	56.2	43.9	83.7	10.0	83.7	83.7	79.3	67.2	54.7	42.5
	57	85.9	8.8	85.9	85.9	84.2	72.0	59.7	47.5	83.0	9.8	83.0	83.0	81.4	69.4	56.8	44.6
	72	105.1	9.2	79.5	66.2	53.0	39.8	-	-	101.3	10.2	78.2	64.9	51.7	38.4	-	-
3750	67	96.6	9.1	95.1	81.9	68.6	55.4	42.1	-	93.2	10.1	93.2	80.7	67.4	54.2	40.9	-
	62	88.8	9.0	88.8	88.8	84.4	71.2	57.9	44.7	85.3	10.0	85.3	85.3	83.1	69.8	56.5	43.3
	57	87.6	8.8	87.6	87.6	87.6	74.3	61.1	47.8	84.6	9.8	84.6	84.6	84.6	71.3	58.1	44.8

¹ These capacities are gross ratings. For net capacity, deduct air blower motor, MBh = 2.547 x HP. Refer to the appropriate Blower Performance Table for the HP of the supply air blower motor.

² These ratings include the condenser fan motors and the compressor motors but not the supply air blower motor.

YC120/NC120

Air on Evaporator Coil		Temperature of Air on Condenser Coil															
CFM	WB (°F)	Total Capacity ¹ (MBh)	Total Input (kW) ²	Sensible Capacity (MBh)						Total Capacity ¹ (MBh)	Total Input (kW) ²	Sensible Capacity (MBh)					
				Return Dry Bulb (°F)								Return Dry Bulb (°F)					
				90	85	80	75	70	65			90	85	80	75	70	65
		75°F							85°F								
3000	77	142.3	7.5	64.7	52.6	40.5	-	-	-	139.4	8.5	67.1	54.6	42.1	-	-	-
	72	133.9	7.4	84.4	72.2	60.1	48.0	-	-	129.5	8.4	85.3	72.8	60.3	47.8	-	-
	67	125.5	7.3	104.0	91.9	79.8	67.7	55.6	-	119.6	8.3	103.4	90.9	78.5	66.0	53.5	-
	62	115.0	7.3	115.0	109.5	94.2	82.0	69.9	57.8	111.3	8.2	111.3	108.6	96.1	83.6	71.1	58.6
	57	111.2	7.2	111.2	111.2	99.9	87.8	75.7	63.6	108.8	8.3	108.8	108.8	99.2	86.7	74.2	61.7
3500	77	151.4	7.5	72.3	58.7	45.2	-	-	-	147.0	8.5	74.2	60.2	46.1	-	-	-
	72	142.4	7.4	94.1	80.6	67.0	53.5	-	-	136.6	8.4	94.1	80.0	66.0	51.9	-	-
	67	133.4	7.3	116.0	102.5	88.9	75.4	61.8	-	126.1	8.3	114.0	99.9	85.9	71.8	57.8	-
	62	122.3	7.3	122.3	119.6	105.0	92.1	77.9	64.4	117.4	8.3	117.4	116.1	105.2	91.1	77.1	63.1
	57	118.3	7.2	118.3	118.3	111.3	98.6	84.2	70.7	114.8	8.3	114.8	114.8	108.6	94.6	80.5	66.5
4000	77	160.5	7.5	79.8	64.9	49.9	-	-	-	154.6	8.6	81.3	65.7	50.1	-	-	-
	72	150.9	7.4	103.9	88.9	73.9	59.0	-	-	143.7	8.5	102.9	87.3	71.7	56.1	-	-
	67	141.4	7.3	128.0	113.0	98.0	83.0	68.1	-	132.7	8.4	124.5	108.9	93.3	77.7	62.1	-
	62	129.6	7.3	129.6	129.6	115.9	102.2	86.0	71.0	123.5	8.3	123.5	123.5	114.3	98.7	83.1	67.5
	57	125.4	7.2	125.4	125.4	122.8	109.5	92.8	77.8	120.7	8.3	120.7	120.7	118.0	102.4	86.8	71.2
4500	72	154.4	7.5	110.8	94.3	77.8	61.4	-	-	148.2	8.5	110.7	93.7	76.6	59.6	-	-
	67	144.7	7.4	138.0	119.7	103.2	86.8	70.3	-	136.9	8.4	132.8	116.7	99.7	82.6	65.6	-
	62	132.6	7.3	132.6	132.6	124.4	108.6	91.5	75.0	127.4	8.3	127.4	127.4	122.1	105.1	88.0	70.9
	57	128.3	7.3	128.3	128.3	127.0	111.4	94.0	77.6	124.6	8.3	124.6	124.6	123.2	106.1	89.1	72.0
	72	157.9	7.5	117.6	99.7	81.7	63.8	-	-	152.7	8.5	118.6	100.0	81.5	63.0	-	-
5000	67	148.0	7.4	148.0	126.4	108.5	90.5	72.6	-	141.1	8.4	141.1	124.6	106.1	87.6	69.1	-
	62	135.6	7.3	135.6	135.6	132.9	114.9	97.0	79.1	131.3	8.3	131.3	131.3	129.9	111.4	92.9	74.4
	57	131.2	7.3	131.2	131.2	131.2	113.2	95.3	77.4	128.4	8.4	128.4	128.4	128.4	109.9	91.4	72.8
			95°F							105°F							
	3000	77	136.4	9.5	69.6	56.7	43.8	-	-	-	127.0	10.7	66.5	53.5	40.6	-	-
72		125.1	9.4	86.2	73.3	60.5	47.6	-	-	117.1	10.7	83.6	70.6	57.7	44.8	-	-
67		113.7	9.3	102.9	90.0	77.1	64.2	51.3	-	107.2	10.6	100.7	87.8	74.8	61.9	48.9	-
62		107.7	9.2	107.7	107.7	98.1	85.2	72.3	59.4	100.8	10.5	100.8	100.8	93.7	80.8	67.9	54.9
57		106.5	9.3	106.5	106.5	98.6	85.7	72.8	59.9	100.2	10.6	100.2	100.2	91.6	78.7	65.8	52.8
3500	77	142.6	9.5	76.1	61.6	47.1	-	-	-	133.4	10.8	75.3	58.7	44.1	-	-	-
	72	130.7	9.4	94.0	79.5	64.9	50.4	-	-	123.1	10.7	92.0	77.3	62.7	48.1	-	-
	67	118.9	9.4	111.9	97.4	82.8	68.3	53.7	-	112.7	10.6	108.7	96.0	81.3	66.7	52.0	-
	62	112.6	9.2	112.6	112.6	105.3	90.2	76.3	61.7	106.0	10.5	106.0	106.0	101.9	86.9	72.6	57.9
	57	111.3	9.4	111.3	111.3	105.9	90.5	76.8	62.3	105.3	10.6	105.3	105.3	99.5	84.5	70.3	55.6
4000	77	148.8	9.6	82.7	66.5	50.3	-	-	-	139.9	10.8	84.1	63.9	47.6	-	-	-
	72	136.4	9.5	101.8	85.6	69.4	53.2	-	-	129.0	10.7	100.4	84.0	67.7	51.3	-	-
	67	124.0	9.4	120.9	104.7	88.5	72.3	56.1	-	118.2	10.6	116.6	104.1	87.8	71.5	55.1	-
	62	117.4	9.2	117.4	117.4	112.6	95.1	80.2	64.0	111.1	10.5	111.1	111.1	110.0	93.0	77.3	60.9
	57	116.1	9.4	116.1	116.1	113.2	95.3	80.8	64.6	110.5	10.6	110.5	110.5	107.4	90.2	74.7	58.4
4500	72	142.0	9.5	110.7	93.0	75.4	57.7	-	-	133.3	10.7	109.1	91.2	73.2	55.2	-	-
	67	129.1	9.4	127.5	113.8	96.1	78.5	60.8	-	122.1	10.6	121.3	112.3	95.0	77.0	59.0	-
	62	122.2	9.3	122.2	122.2	119.8	101.5	84.5	66.9	114.8	10.5	114.8	114.8	114.3	96.0	78.3	60.4
	57	120.8	9.4	120.8	120.8	119.4	100.9	84.1	66.4	114.1	10.6	114.1	114.1	112.6	94.2	76.7	58.7
	72	147.5	9.5	119.5	100.4	81.3	62.2	-	-	137.7	10.7	117.9	98.3	78.7	59.1	-	-
5000	67	134.1	9.4	134.1	122.8	103.7	84.6	65.5	-	126.1	10.7	126.1	120.4	102.1	82.5	62.9	-
	62	127.0	9.3	127.0	127.0	127.0	107.9	88.8	69.7	118.5	10.5	118.5	118.5	118.5	99.0	79.4	59.8
	57	125.6	9.4	125.6	125.6	125.6	106.5	87.4	68.3	117.8	10.6	117.8	117.8	117.8	98.2	78.7	59.1

YC120/NC120 (Continued)

Air on Evaporator Coil		Temperature of Air on Condenser Coil																	
CFM	WB (°F)	Total Capacity ¹ (MBh)	Total Input (kW) ²	Sensible Capacity (MBh)						Total Capacity ¹ (MBh)	Total Input (kW) ²	Sensible Capacity (MBh)							
				Return Dry Bulb (°F)								Return Dry Bulb (°F)							
				90	85	80	75	70	65			90	85	80	75	70	65		
		115°F						125°F											
3000	77	117.5	12.0	63.4	50.4	37.4	-	-	-	108.0	13.2	60.3	47.2	34.1	-	-	-		
	72	109.1	11.9	81.0	68.0	55.0	41.9	-	-	101.2	13.2	78.4	65.3	52.2	39.1	-	-		
	67	100.8	11.9	98.6	85.6	72.6	59.5	46.5	-	94.3	13.1	94.3	83.4	70.3	57.2	44.1	-		
	62	94.0	11.8	94.0	94.0	89.4	76.4	63.4	50.4	87.2	13.0	87.2	87.2	85.1	72.0	59.0	45.9		
	57	94.0	11.8	94.0	94.0	84.7	71.7	58.7	45.7	87.8	13.1	87.8	87.8	77.8	64.7	51.7	38.6		
3500	77	124.2	12.0	74.4	55.8	41.1	-	-	-	115.1	13.2	73.6	53.0	38.1	-	-	-		
	72	115.4	11.9	89.9	75.2	60.4	45.7	-	-	107.7	13.2	87.9	73.1	58.2	43.4	-	-		
	67	106.6	11.9	105.5	94.6	79.8	65.1	50.3	-	100.4	13.1	100.4	93.2	78.3	63.5	48.6	-		
	62	99.4	11.8	99.4	99.4	98.4	83.6	68.9	54.1	92.8	13.0	92.8	92.8	92.8	80.4	65.2	50.3		
	57	99.4	11.8	99.4	99.4	93.2	78.5	63.7	49.0	93.5	13.1	93.5	93.5	86.9	72.4	57.2	42.3		
4000	77	131.0	12.0	85.5	61.3	44.8	-	-	-	122.1	13.2	86.9	58.7	42.1	-	-	-		
	72	121.7	11.9	98.9	82.4	65.9	49.5	-	-	114.3	13.2	97.5	80.8	64.2	47.6	-	-		
	67	112.3	11.9	112.3	103.5	87.1	70.6	54.1	-	106.5	13.1	106.5	103.0	86.3	69.7	53.1	-		
	62	104.8	11.8	104.8	104.8	107.3	90.8	74.4	57.9	98.5	13.1	98.5	98.5	98.5	88.7	71.4	54.8		
	57	104.8	11.8	104.8	104.8	101.7	85.2	68.7	52.2	99.2	13.1	99.2	99.2	95.9	80.1	62.7	46.0		
4500	72	124.7	11.9	107.6	89.3	71.0	52.8	-	-	116.1	13.2	106.1	87.5	68.9	50.3	-	-		
	67	115.2	11.9	115.2	110.8	93.8	75.5	57.2	-	108.2	13.1	108.2	108.2	92.6	74.0	55.4	-		
	62	107.4	11.8	107.4	107.4	108.7	90.4	72.1	53.8	100.0	13.1	100.0	100.0	100.0	84.9	65.9	47.3		
	57	107.4	11.8	107.4	107.4	105.9	87.6	69.3	51.0	100.7	13.1	100.7	100.7	99.1	80.9	61.9	43.3		
	5000	72	127.8	12.0	116.3	96.2	76.1	56.1	-	-	117.9	13.2	114.7	94.1	73.6	53.0	-	-	
67		118.0	11.9	118.0	118.0	100.5	80.4	60.4	-	109.9	13.1	109.9	109.9	98.9	78.4	57.8	-		
62		110.1	11.8	110.1	110.1	110.1	90.0	69.9	49.8	101.6	13.0	101.6	101.6	101.6	81.0	60.4	39.9		
57		110.1	11.9	110.1	110.1	110.1	90.0	69.9	49.8	102.3	13.1	102.3	102.3	102.3	81.7	61.2	40.6		

¹ These capacities are gross ratings. For net capacity, deduct air blower motor, MBh = 2.547 x HP. Refer to the appropriate Blower Performance Table for the HP of the supply air blower motor.

² These ratings include the condenser fan motors and the compressor motors but not the supply air blower motor.

YC150/NC180

Air on Evaporator Coil		Temperature of Air on Condenser Coil															
CFM	WB (°F)	Total Capacity ¹ (MBh)	Total Input (kW) ²	Sensible Capacity (MBh)						Total Capacity ¹ (MBh)	Total Input (kW) ²	Sensible Capacity (MBh)					
				Return Dry Bulb (°F)								Return Dry Bulb (°F)					
				90	85	80	75	70	65			90	85	80	75	70	65
		75°F								85°F							
3750	77	178.5	10.2	87.6	71.1	54.7	-	-	-	172.2	11.3	84.0	67.6	51.2	-	-	-
	72	168.2	9.9	111.9	95.4	78.9	62.4	-	-	161.2	11.0	108.3	91.9	75.5	59.2	-	-
	67	157.9	9.6	136.1	119.6	103.1	86.7	70.2	-	150.1	10.7	132.5	116.2	99.8	83.4	67.1	-
	62	144.8	9.4	144.8	144.8	129.3	112.8	96.3	79.8	138.9	10.6	138.9	138.9	126.4	110.1	93.7	77.3
	57	149.7	9.5	149.7	149.7	137.7	121.2	104.7	88.3	143.9	10.7	143.9	143.9	130.6	114.3	97.9	81.5
4375	77	184.7	10.2	94.2	77.2	58.5	-	-	-	177.6	11.3	92.4	73.7	55.0	-	-	-
	72	174.0	9.9	121.8	103.1	84.4	65.7	-	-	166.2	11.0	118.4	99.8	81.1	62.4	-	-
	67	163.4	9.6	149.5	129.0	110.3	91.6	72.9	-	154.7	10.8	144.5	125.8	107.1	88.4	69.8	-
	62	149.9	9.4	149.9	149.9	138.2	119.8	100.8	82.1	143.2	10.6	143.2	143.2	135.7	117.0	98.4	79.7
	57	154.9	9.5	154.9	154.9	147.3	129.1	109.8	91.1	148.4	10.7	148.4	148.4	140.2	121.6	102.9	84.2
5000	77	190.9	10.3	100.7	83.2	62.3	-	-	-	182.9	11.3	100.8	79.8	58.8	-	-	-
	72	179.9	9.9	131.8	110.8	89.9	68.9	-	-	171.2	11.0	128.6	107.6	86.6	65.6	-	-
	67	168.8	9.6	162.9	138.4	117.5	96.5	75.5	-	159.4	10.8	156.5	135.5	114.5	93.5	72.5	-
	62	154.9	9.4	154.9	154.9	147.2	126.8	105.3	84.3	147.5	10.6	147.5	147.5	145.0	124.0	103.0	82.0
	57	160.1	9.6	160.1	160.1	156.9	137.0	114.9	94.0	152.9	10.7	152.9	152.9	149.8	128.8	107.8	86.8
5625	72	182.3	10.1	142.7	119.7	96.7	73.7	-	-	174.1	11.2	139.0	116.1	93.1	70.2	-	-
	67	171.1	9.8	168.1	149.4	126.4	103.4	80.4	-	162.1	10.9	160.6	146.0	123.1	100.1	77.2	-
	62	157.0	9.6	157.0	157.0	153.1	130.4	107.1	84.1	150.0	10.7	150.0	150.0	148.8	125.8	102.9	79.9
	57	162.2	9.7	162.2	162.2	160.6	138.1	114.6	91.6	155.5	10.8	155.5	155.5	153.9	131.0	108.1	85.1
	6250	72	184.7	10.2	153.7	128.6	103.6	78.5	-	-	177.0	11.3	149.4	124.5	99.7	74.8	-
67		173.4	9.9	173.4	160.4	135.4	110.4	85.3	-	164.8	11.0	164.8	156.6	131.7	106.8	81.9	-
62		159.0	9.7	159.0	159.0	159.0	134.0	108.9	83.9	152.5	10.8	152.5	152.5	152.5	127.6	102.7	77.8
57		164.4	9.8	164.4	164.4	164.4	139.3	114.3	89.2	158.1	10.9	158.1	158.1	158.1	133.2	108.3	83.4
		95°F								105°F							
3750	77	166.0	12.3	80.3	64.1	47.8	-	-	-	159.9	14.1	79.0	62.8	46.6	-	-	-
	72	154.1	12.1	104.7	88.4	72.2	55.9	-	-	148.2	13.8	102.8	86.6	70.4	54.2	-	-
	67	142.3	11.9	129.0	112.7	96.5	80.2	64.0	-	136.4	13.5	126.7	110.5	94.2	78.0	61.8	-
	62	132.9	11.7	132.9	132.9	123.6	107.4	91.1	74.9	130.6	13.4	130.6	130.6	122.0	105.8	89.6	73.4
	57	138.2	11.8	138.2	138.2	123.6	107.3	91.1	74.8	134.7	13.5	134.7	134.7	119.4	103.2	87.0	70.8
4375	77	170.5	12.3	90.6	70.2	51.6	-	-	-	163.0	14.0	91.5	68.6	50.0	-	-	-
	72	158.3	12.1	115.0	96.4	77.8	59.1	-	-	151.0	13.7	112.8	94.2	75.6	56.9	-	-
	67	146.1	11.9	139.5	122.6	104.0	85.3	66.7	-	139.1	13.5	134.2	119.8	101.2	82.5	63.9	-
	62	136.5	11.7	136.5	136.5	133.2	114.3	95.9	77.3	133.1	13.4	133.1	133.1	130.9	112.1	93.6	75.0
	57	142.0	11.8	142.0	142.0	133.2	114.0	95.9	77.3	137.3	13.5	137.3	137.3	128.1	109.2	90.9	72.2
5000	77	175.0	12.3	100.8	76.3	55.3	-	-	-	166.1	13.9	104.0	74.4	53.4	-	-	-
	72	162.5	12.1	125.4	104.4	83.4	62.3	-	-	153.9	13.7	122.9	101.8	80.7	59.6	-	-
	67	150.0	11.9	150.0	132.5	111.5	90.4	69.4	-	141.7	13.4	141.7	129.1	108.1	87.0	65.9	-
	62	140.1	11.7	140.1	140.1	142.8	121.2	100.7	79.7	135.6	13.3	135.6	135.6	139.8	118.5	97.7	76.6
	57	145.7	11.8	145.7	145.7	142.8	120.7	100.7	79.7	140.0	13.4	140.0	140.0	136.9	115.3	94.8	73.7
5625	72	165.9	12.2	135.3	112.4	89.5	66.7	-	-	157.7	13.8	133.0	110.0	87.1	64.2	-	-
	67	153.1	12.0	153.1	142.6	119.7	96.8	73.9	-	145.2	13.5	145.2	138.0	116.6	93.7	70.8	-
	62	143.1	11.8	143.1	143.1	144.4	121.2	98.6	75.7	138.9	13.4	138.9	138.9	141.0	118.0	95.2	72.3
	57	148.7	11.9	148.7	148.7	147.3	123.9	101.5	78.6	143.4	13.5	143.4	143.4	141.8	118.6	96.0	73.1
	6250	72	169.3	12.3	145.2	120.5	95.7	71.0	-	-	161.4	14.0	143.0	118.3	93.5	68.7	-
67		156.3	12.1	156.3	152.7	128.0	103.2	78.5	-	148.6	13.7	148.6	146.9	125.2	100.4	75.6	-
62		146.0	11.9	146.0	146.0	146.0	121.3	96.5	71.8	142.2	13.6	142.2	142.2	142.2	117.5	92.7	67.9
57		151.8	12.0	151.8	151.8	151.8	127.0	102.3	77.6	146.8	13.7	146.8	146.8	146.8	122.0	97.2	72.5

YC150/NC180 (Continued)

Air on Evaporator Coil		Temperature of Air on Condenser Coil															
CFM	WB (°F)	Total Capacity ¹ (MBh)	Total Input (kW) ²	Sensible Capacity (MBh)						Total Capacity ¹ (MBh)	Total Input (kW) ²	Sensible Capacity (MBh)					
				Return Dry Bulb (°F)								Return Dry Bulb (°F)					
				90	85	80	75	70	65			90	85	80	75	70	65
				115°F						125°F							
3750	77	153.8	15.8	77.6	61.4	45.3	-	-	-	147.7	17.5	76.3	60.1	44.0	-	-	-
	72	142.2	15.5	101.0	84.8	68.7	52.5	-	-	136.2	17.2	99.2	83.0	66.9	50.8	-	-
	67	130.5	15.1	124.4	108.2	92.0	75.9	59.7	-	124.7	16.8	122.1	105.9	89.8	73.7	57.6	-
	62	128.2	15.1	128.2	128.2	120.4	104.2	88.0	71.9	125.8	16.8	125.8	125.8	118.7	102.6	86.5	70.4
	57	131.2	15.2	131.2	131.2	115.2	99.0	82.8	66.7	127.8	17.0	127.8	127.8	111.0	94.9	78.7	62.6
4375	77	155.5	15.7	92.3	67.0	48.4	-	-	-	148.1	17.3	93.2	65.4	46.8	-	-	-
	72	143.8	15.3	110.6	92.0	73.4	54.7	-	-	136.5	17.0	108.4	89.8	71.2	52.5	-	-
	67	132.0	15.0	128.9	117.0	98.3	79.7	61.1	-	125.0	16.6	123.7	114.2	95.5	76.9	58.3	-
	62	129.7	15.0	129.7	129.7	128.6	110.0	91.3	72.7	126.2	16.7	126.2	126.2	126.2	107.8	89.1	70.4
	57	132.7	15.1	132.7	132.7	123.1	104.4	85.8	67.2	128.1	16.8	128.1	128.1	118.0	99.7	80.8	62.1
5000	77	157.3	15.5	107.1	72.6	51.5	-	-	-	148.4	17.1	110.2	70.7	49.6	-	-	-
	72	145.4	15.2	120.3	99.2	78.1	57.0	-	-	136.8	16.8	117.7	96.6	75.4	54.3	-	-
	67	133.5	14.9	133.5	125.8	104.7	83.6	62.5	-	125.2	16.4	125.2	122.4	101.3	80.1	59.0	-
	62	131.1	14.9	131.1	131.1	136.9	115.8	94.7	73.6	126.6	16.5	126.6	126.6	126.6	113.1	91.6	70.5
	57	134.2	15.0	134.2	134.2	131.0	109.9	88.8	67.7	128.5	16.6	128.5	128.5	125.1	104.5	82.8	61.7
5625	72	149.5	15.4	130.6	107.6	84.7	61.7	-	-	141.3	17.0	128.2	105.2	82.3	59.3	-	-
	67	137.3	15.1	137.3	133.4	113.5	90.6	67.6	-	129.3	16.6	129.3	128.8	110.4	87.5	64.5	-
	62	134.8	15.1	134.8	134.8	137.7	114.7	91.8	68.8	130.7	16.7	130.7	130.7	130.7	111.5	88.4	65.4
	57	138.0	15.2	138.0	138.0	136.4	113.4	90.5	67.5	132.6	16.8	132.6	132.6	130.9	108.2	84.9	62.0
	72	153.6	15.6	140.9	116.1	91.3	66.5	-	-	145.7	17.2	138.7	113.9	89.1	64.3	-	-
6250	67	141.0	15.3	141.0	141.0	122.4	97.6	72.8	-	133.4	16.8	133.4	133.4	119.6	94.8	69.9	-
	62	138.5	15.3	138.5	138.5	138.5	113.7	88.9	64.1	134.7	16.9	134.7	134.7	134.7	109.9	85.1	60.2
	57	141.8	15.4	141.8	141.8	141.8	117.0	92.2	67.4	136.7	17.1	136.7	136.7	136.7	111.9	87.1	62.3

¹ These capacities are gross ratings. For net capacity, deduct air blower motor, MBh = 2.547 x HP. Refer to the appropriate Blower Performance Table for the HP of the supply air blower motor.

² These ratings include the condenser fan motors and the compressor motors but not the supply air blower motor.

YC180/NC180

Air on Evaporator Coil		Temperature of Air on Condenser Coil																	
CFM	WB (°F)	Total Capacity ¹ (MBh)	Total Input (kW) ²	Sensible Capacity (MBh)							Total Capacity ¹ (MBh)	Total Input (kW) ²	Sensible Capacity (MBh)						
				Return Dry Bulb (°F)									Return Dry Bulb (°F)						
				90	85	80	75	70	65	90			85	80	75	70	65		
		75°F								85°F									
4500	77	223.5	11.8	104.0	85.0	66.0	-	-	-	214.6	13.1	101.2	82.2	63.3	-	-	-		
	72	207.2	11.5	132.3	113.3	94.4	75.4	-	-	198.3	12.8	129.0	110.1	91.2	72.2	-	-		
	67	191.0	11.1	160.6	141.7	122.7	103.7	84.7	-	181.9	12.4	156.8	137.9	119.0	100.1	81.1	-		
	62	176.0	10.8	176.0	171.9	151.4	132.5	113.5	94.5	168.5	12.2	168.5	166.4	147.5	128.6	109.7	90.8		
	57	175.0	10.8	175.0	175.0	158.1	139.1	120.1	101.1	168.1	12.1	168.1	168.1	150.6	131.7	112.8	93.8		
5250	77	229.4	11.9	113.7	92.3	70.8	-	-	-	220.1	13.2	110.7	89.4	68.1	-	-	-		
	72	212.8	11.6	144.1	122.7	101.2	79.7	-	-	203.3	12.8	140.7	119.4	98.1	76.8	-	-		
	67	196.1	11.2	174.5	153.0	131.6	110.1	88.7	-	186.5	12.5	170.6	149.3	128.0	106.7	85.4	-		
	62	180.7	11.0	180.7	178.6	162.4	141.9	119.5	98.1	172.7	12.2	172.7	171.7	158.7	137.4	116.1	94.8		
	57	179.7	10.9	179.7	179.7	169.6	149.6	126.6	105.2	172.4	12.2	172.4	172.4	162.0	140.7	119.4	98.1		
6000	77	235.4	12.0	123.5	99.5	75.6	-	-	-	225.5	13.3	120.3	96.6	72.9	-	-	-		
	72	218.3	11.7	155.9	132.0	108.0	84.1	-	-	208.3	12.9	152.3	128.6	105.0	81.3	-	-		
	67	201.2	11.3	188.3	164.4	140.5	116.5	92.6	-	191.1	12.6	184.4	160.7	137.0	113.4	89.7	-		
	62	185.4	11.1	185.4	185.4	173.4	151.3	125.5	101.6	177.0	12.3	177.0	177.0	169.9	146.2	122.6	98.9		
	57	184.4	11.0	184.4	184.4	181.0	160.1	133.2	109.2	176.6	12.3	176.6	176.6	173.5	149.8	126.1	102.4		
6750	72	221.3	11.3	165.2	139.4	113.7	88.0	-	-	213.7	13.6	165.8	140.1	114.5	88.8	-	-		
	67	204.0	11.0	197.5	174.0	147.8	122.0	96.3	-	196.0	13.3	192.7	175.1	149.4	123.8	98.1	-		
	62	187.9	10.7	187.9	187.9	181.9	157.1	130.4	104.7	181.5	13.0	181.5	181.5	178.0	152.4	126.7	101.1		
	57	186.8	10.6	186.8	186.8	185.2	161.0	133.7	108.0	181.2	13.0	181.2	181.2	179.6	153.9	128.3	102.6		
	72	224.2	10.9	174.4	146.9	119.4	91.8	-	-	219.0	14.3	179.2	151.6	123.9	96.3	-	-		
7500	67	206.7	10.6	206.7	183.6	155.1	127.6	100.0	-	201.0	14.0	201.0	189.4	161.8	134.1	106.5	-		
	62	190.4	10.3	190.4	190.4	190.4	162.8	135.3	107.8	186.1	13.7	186.1	186.1	186.1	158.5	130.9	103.2		
	57	189.3	10.3	189.3	189.3	189.3	161.8	134.3	106.7	185.7	13.7	185.7	185.7	185.7	158.1	130.5	102.9		
			95°F								105°F								
	4500	77	205.8	14.4	98.3	79.5	60.6	-	-	-	195.5	15.9	95.5	76.6	57.7	-	-	-	
72		189.3	14.0	125.7	106.8	87.9	69.1	-	-	179.9	15.7	122.5	103.6	84.7	65.9	-	-		
67		172.8	13.7	153.0	134.1	115.3	96.4	77.5	-	164.3	15.4	149.5	130.7	111.8	92.9	74.0	-		
62		161.0	13.5	161.0	161.0	143.6	124.7	105.9	87.0	153.2	15.2	153.2	153.2	139.8	120.9	102.0	83.1		
57		161.3	13.5	161.3	161.3	143.1	124.3	105.4	86.6	154.3	15.2	154.3	154.3	136.3	117.4	98.5	79.6		
5250	77	210.7	14.4	107.7	86.6	65.4	-	-	-	199.9	16.0	107.5	83.6	62.4	-	-	-		
	72	193.8	14.1	137.2	116.1	94.9	73.8	-	-	183.9	15.8	134.0	112.8	91.6	70.4	-	-		
	67	176.9	13.8	166.7	145.6	124.4	103.3	82.2	-	168.0	15.5	160.4	142.0	120.8	99.6	78.3	-		
	62	164.8	13.5	164.8	164.8	155.0	132.9	112.7	91.6	156.6	15.2	156.6	156.6	151.0	129.4	108.6	87.4		
	57	165.1	13.6	165.1	165.1	154.5	131.9	112.2	91.1	157.7	15.2	157.7	157.7	147.2	125.3	104.8	83.6		
6000	77	215.5	14.5	117.1	93.7	70.2	-	-	-	204.2	16.1	119.5	90.5	67.0	-	-	-		
	72	198.3	14.2	148.7	125.3	101.9	78.5	-	-	187.9	15.8	145.4	121.9	98.4	74.9	-	-		
	67	181.0	13.8	180.4	157.0	133.6	110.2	86.8	-	171.6	15.6	171.3	153.3	129.7	106.2	82.7	-		
	62	168.6	13.6	168.6	168.6	166.4	141.1	119.6	96.2	160.0	15.3	160.0	160.0	162.3	137.8	115.3	91.7		
	57	168.9	13.6	168.9	168.9	165.9	139.4	119.1	95.6	161.2	15.3	161.2	161.2	158.2	133.2	111.2	87.6		
6750	72	206.1	15.9	166.4	140.8	115.2	89.7	-	-	192.5	16.7	159.1	133.4	107.7	82.0	-	-		
	67	188.1	15.6	187.8	176.1	151.0	125.5	99.9	-	175.8	16.4	175.7	166.6	142.0	116.3	90.7	-		
	62	175.2	15.3	175.2	175.2	174.1	147.6	123.0	97.4	164.0	16.2	164.0	164.0	165.1	139.0	113.7	88.1		
	57	175.5	15.3	175.5	175.5	174.0	146.9	122.9	97.3	165.1	16.2	165.1	165.1	163.6	137.2	112.3	86.6		
	72	213.9	17.7	184.0	156.3	128.5	100.8	-	-	197.2	17.6	172.7	144.9	117.0	89.2	-	-		
7500	67	195.2	17.3	195.2	195.2	168.5	140.7	113.0	-	180.0	17.3	180.0	180.0	154.3	126.5	98.6	-		
	62	181.9	17.0	181.9	181.9	181.9	154.1	126.4	98.6	167.9	17.0	167.9	167.9	167.9	140.1	112.2	84.4		
	57	182.2	17.0	182.2	182.2	182.2	154.4	126.7	99.0	169.0	17.0	169.0	169.0	169.0	141.2	113.4	85.6		

YC180/NC180 (Continued)

Air on Evaporator Coil		Temperature of Air on Condenser Coil															
CFM	WB (°F)	Total Capacity ¹ (MBh)	Total Input (kW) ²	Sensible Capacity (MBh)						Total Capacity ¹ (MBh)	Total Input (kW) ²	Sensible Capacity (MBh)					
				Return Dry Bulb (°F)								Return Dry Bulb (°F)					
				90	85	80	75	70	65			90	85	80	75	70	65
				115°F						125°F							
4500	77	185.3	17.5	92.7	73.7	54.8	-	-	-	175.0	19.1	89.8	70.9	51.9	-	-	-
	72	170.5	17.3	119.4	100.5	81.5	62.6	-	-	161.1	18.9	116.2	97.3	78.4	59.4	-	-
	67	155.8	17.1	146.1	127.2	108.3	89.3	70.4	-	147.2	18.8	142.6	123.7	104.8	85.8	66.9	-
	62	145.5	16.9	145.5	145.5	136.0	117.1	98.2	79.3	137.7	18.6	137.7	137.7	132.2	113.3	94.3	75.4
	57	147.3	16.8	147.3	147.3	129.4	110.5	91.6	72.7	140.3	18.5	140.3	140.3	122.6	103.6	84.7	65.8
5250	77	189.1	17.6	107.3	80.6	59.3	-	-	-	178.3	19.2	107.1	77.6	56.2	-	-	-
	72	174.1	17.4	130.7	109.5	88.2	66.9	-	-	164.2	19.1	127.5	106.2	84.8	63.5	-	-
	67	159.0	17.2	154.2	138.3	117.1	95.8	74.5	-	150.1	18.9	147.9	134.7	113.4	92.1	70.7	-
	62	148.5	17.0	148.5	148.5	147.1	125.8	104.5	83.3	140.3	18.7	140.3	140.3	140.3	122.2	100.4	79.1
	57	150.4	16.9	150.4	150.4	140.0	118.7	97.4	76.2	143.0	18.6	143.0	143.0	132.7	112.1	90.0	68.7
6000	77	192.9	17.7	121.9	87.4	63.8	-	-	-	181.6	19.3	124.4	84.3	60.5	-	-	-
	72	177.6	17.5	142.1	118.5	94.8	71.2	-	-	167.3	19.2	138.8	115.0	91.3	67.6	-	-
	67	162.2	17.3	162.2	149.5	125.9	102.3	78.6	-	152.9	19.0	152.9	145.8	122.1	98.3	74.6	-
	62	151.5	17.0	151.5	151.5	158.2	134.5	110.9	87.3	142.9	18.8	142.9	142.9	142.9	131.2	106.6	82.8
	57	153.4	17.0	153.4	153.4	150.5	126.9	103.3	79.6	145.7	18.7	145.7	145.7	142.8	120.6	95.4	71.6
6750	72	179.0	17.5	151.7	126.0	100.2	74.4	-	-	165.5	18.3	144.4	118.5	92.7	66.8	-	-
	67	163.5	17.3	163.5	157.2	133.0	107.2	81.5	-	151.3	18.2	151.3	147.7	124.0	98.1	72.3	-
	62	152.7	17.0	152.7	152.7	156.0	130.3	104.5	78.7	141.4	17.9	141.4	141.4	141.4	121.6	95.3	69.4
	57	154.7	17.0	154.7	154.7	153.2	127.4	101.7	75.9	144.2	17.9	144.2	144.2	142.8	117.7	91.0	65.2
	7500	72	180.4	17.5	161.4	133.5	105.5	77.6	-	-	163.7	17.4	150.1	122.1	94.1	66.0	-
67		164.8	17.3	164.8	164.8	140.1	112.2	84.3	-	149.7	17.3	149.7	149.7	125.9	97.9	69.9	-
62		153.9	17.0	153.9	153.9	153.9	126.0	98.1	70.2	140.0	17.1	140.0	140.0	140.0	112.0	83.9	55.9
57		155.9	17.0	155.9	155.9	155.9	128.0	100.1	72.1	142.7	17.0	142.7	142.7	142.7	114.7	86.7	58.7

¹ These capacities are gross ratings. For net capacity, deduct air blower motor, MBh = 2.547 x HP. Refer to the appropriate Blower Performance Table for the HP of the supply air blower motor.

² These ratings include the condenser fan motors and the compressor motors but not the supply air blower motor.

YC180/NC240 (Continued)

Air on Evaporator Coil		Temperature of Air on Condenser Coil															
CFM	WB (°F)	Total Capacity ¹ (MBh)	Total Input (kW) ²	Sensible Capacity (MBh)						Total Capacity ¹ (MBh)	Total Input (kW) ²	Sensible Capacity (MBh)					
				Return Dry Bulb (°F)								Return Dry Bulb (°F)					
				90	85	80	75	70	65			90	85	80	75	70	65
				115°F						125°F							
4500	77	203.2	18.8	106.1	86.7	67.4	-	-	-	198.7	21.0	104.2	84.9	65.6	-	-	-
	72	187.4	18.3	131.7	112.3	93.0	73.7	-	-	182.9	20.3	129.8	110.4	91.1	71.8	-	-
	67	171.6	17.7	157.3	137.9	118.6	99.3	79.9	-	167.2	19.6	155.3	136.0	116.7	97.3	78.0	-
	62	153.7	17.2	153.7	153.7	137.3	117.9	98.6	79.3	149.3	19.0	149.3	149.3	133.5	114.1	94.8	75.5
	57	157.8	17.1	157.8	157.8	141.1	121.7	102.4	83.0	154.9	18.9	154.9	154.9	138.0	118.7	99.4	80.1
5250	77	208.6	19.0	117.7	94.1	72.1	-	-	-	204.0	21.1	116.8	92.2	70.3	-	-	-
	72	192.4	18.4	143.4	121.4	99.5	77.6	-	-	187.8	20.4	141.5	119.6	97.6	75.7	-	-
	67	176.2	17.8	169.0	148.8	126.9	105.0	83.0	-	171.7	19.7	166.2	146.9	125.0	103.0	81.1	-
	62	157.8	17.3	157.8	157.8	146.9	124.9	103.0	81.1	153.3	19.1	153.3	153.3	143.0	121.2	99.1	77.2
	57	162.0	17.2	162.0	162.0	150.9	129.0	107.0	85.1	159.1	19.0	159.1	159.1	147.9	126.3	104.0	82.1
6000	77	214.1	19.1	129.4	101.4	76.8	-	-	-	209.3	21.2	129.3	99.5	74.9	-	-	-
	72	197.4	18.5	155.1	130.6	106.0	81.5	-	-	192.8	20.5	153.2	128.7	104.1	79.6	-	-
	67	180.8	17.9	180.8	159.7	135.2	110.7	86.1	-	176.2	19.8	176.2	157.8	133.3	108.8	84.2	-
	62	162.0	17.4	162.0	162.0	156.5	131.9	107.4	82.8	157.3	19.2	157.3	157.3	152.5	128.2	103.4	78.9
	57	166.3	17.3	166.3	166.3	160.8	136.3	111.7	87.2	163.2	19.1	163.2	163.2	157.8	133.8	108.7	84.1
6750	72	200.5	18.5	165.1	138.2	111.4	84.5	-	-	195.9	20.5	163.2	136.3	109.5	82.6	-	-
	67	183.6	17.9	183.6	168.9	142.0	115.2	88.3	-	179.1	19.7	179.1	167.0	140.2	113.3	86.5	-
	62	164.5	17.4	164.5	164.5	161.7	134.9	108.0	81.2	159.9	19.2	159.9	159.9	157.5	130.8	103.8	77.0
	57	168.8	17.3	168.8	168.8	166.1	139.3	112.4	85.6	165.9	19.0	165.9	165.9	163.2	136.7	109.5	82.7
	7500	72	203.6	18.5	175.0	145.9	116.7	87.6	-	-	199.1	20.4	173.1	144.0	114.9	85.7	-
67		186.4	17.9	186.4	178.0	148.8	119.7	90.5	-	182.0	19.7	182.0	176.2	147.0	117.9	88.7	-
62		167.0	17.4	167.0	167.0	167.0	137.8	108.7	79.5	162.5	19.2	162.5	162.5	162.5	133.3	104.2	75.0
57		171.4	17.3	171.4	171.4	171.4	142.3	113.1	83.9	168.6	19.0	168.6	168.6	168.6	139.5	110.3	81.2

¹ These capacities are gross ratings. For net capacity, deduct air blower motor, MBh = 2.547 x HP. Refer to the appropriate Blower Performance Table for the HP of the supply air blower motor.

² These ratings include the condenser fan motors and the compressor motors but not the supply air blower motor.

YC240/NC240 (Continued)

Air on Evaporator Coil		Temperature of Air on Condenser Coil															
CFM	WB (°F)	Total Capacity ¹ (MBh)	Total Input (kW) ²	Sensible Capacity (MBh)						Total Capacity ¹ (MBh)	Total Input (kW) ²	Sensible Capacity (MBh)					
				Return Dry Bulb (°F)								Return Dry Bulb (°F)					
				90	85	80	75	70	65			90	85	80	75	70	65
				115°F						125°F							
6000	77	244.4	23.4	120.7	96.0	71.4	-	-	-	229.9	25.9	117.5	92.5	67.5	-	-	-
	72	226.2	22.8	156.5	131.9	107.2	82.6	-	-	212.8	25.1	153.2	128.2	103.2	78.1	-	-
	67	208.0	22.1	192.4	167.7	143.1	118.5	93.8	-	195.7	24.3	188.9	163.9	138.9	113.8	88.8	-
	62	192.2	21.6	192.2	192.2	178.1	153.5	128.8	104.2	179.4	23.8	179.4	179.4	173.7	148.6	123.6	98.6
	57	194.4	21.8	194.4	194.4	174.8	150.2	125.5	100.9	184.6	23.9	184.6	184.6	162.9	137.9	112.9	87.8
7000	77	250.0	23.5	136.5	104.5	76.9	-	-	-	235.5	25.9	135.8	101.0	72.8	-	-	-
	72	231.4	22.8	170.8	143.1	115.5	87.9	-	-	218.0	25.1	167.7	139.5	111.3	83.1	-	-
	67	212.8	22.1	205.0	181.7	154.1	126.5	98.9	-	200.5	24.3	199.6	178.0	149.8	121.6	93.4	-
	62	196.7	21.7	196.7	196.7	191.8	164.2	136.5	108.9	183.8	23.8	183.8	183.8	183.8	159.9	130.9	102.7
	57	198.9	21.8	198.9	198.9	188.3	160.6	133.0	105.4	189.1	24.0	189.1	189.1	175.8	148.8	119.4	91.2
8000	77	255.7	23.5	152.4	113.0	82.4	-	-	-	241.1	25.9	154.0	109.5	78.1	-	-	-
	72	236.6	22.8	185.0	154.4	123.7	93.1	-	-	223.2	25.1	182.1	150.8	119.4	88.0	-	-
	67	217.6	22.2	217.6	195.7	165.1	134.5	103.9	-	205.3	24.3	205.3	192.1	160.7	129.3	97.9	-
	62	201.1	21.7	201.1	201.1	205.5	174.9	144.3	113.6	188.2	23.9	188.2	188.2	188.2	171.2	138.2	106.9
	57	203.3	21.8	203.3	203.3	201.7	171.1	140.5	109.8	193.6	24.0	193.6	193.6	188.6	159.7	125.9	94.5
9000	72	241.9	23.0	195.9	162.8	129.7	96.5	-	-	228.6	25.4	193.3	159.5	125.8	92.0	-	-
	67	222.4	22.3	222.4	206.1	173.0	139.9	106.8	-	210.3	24.6	210.3	203.0	169.3	135.5	101.7	-
	62	205.6	21.9	205.6	205.6	207.8	174.6	141.5	108.4	192.7	24.1	192.7	192.7	192.7	167.4	132.8	99.0
	57	207.9	22.0	207.9	207.9	207.0	173.9	140.8	107.7	198.3	24.2	198.3	198.3	195.8	163.2	128.2	94.4
	72	247.2	23.2	206.8	171.2	135.6	100.0	-	-	233.9	25.6	204.5	168.3	132.1	95.9	-	-
10000	67	227.3	22.5	227.3	216.5	180.9	145.3	109.7	-	215.2	24.8	215.2	214.0	177.8	141.6	105.4	-
	62	210.0	22.0	210.0	210.0	210.0	174.4	138.8	103.2	197.3	24.3	197.3	197.3	197.3	163.5	127.4	91.2
	57	212.4	22.2	212.4	212.4	212.4	176.8	141.2	105.6	202.9	24.5	202.9	202.9	202.9	166.7	130.5	94.3

¹ These capacities are gross ratings. For net capacity, deduct air blower motor, MBh = 2.547 x HP. Refer to the appropriate Blower Performance Table for the HP of the supply air blower motor.

² These ratings include the condenser fan motors and the compressor motors but not the supply air blower motor.

Condenser Only Cooling Capacities**Condenser Only Ratings**

Model	Suction Press. and Corresponding Temp.		Temperature of Air on Condenser Coil °F																	
			65			75			85			95			105			115		
	PSIG	°F	MBH	KW	EER	MBH	KW	EER	MBH	KW	EER	MBH	KW	EER	MBH	KW	EER	MBH	KW	EER
YC090	108	35	78	4.8	16.1	75	5.3	14.2	72	5.8	12.4	68	6.5	10.3	61	7.6	8.1	55	8.6	6.4
	120	40	88	5.0	17.6	84	5.5	15.5	81	5.9	13.6	76	6.7	11.4	70	7.7	9.1	64	8.7	7.3
	131	45	98	5.1	19.1	94	5.6	16.7	89	6.1	14.7	85	6.8	12.4	79	7.8	10.0	72	8.9	8.2
	143	50	108	5.3	20.5	103	5.8	17.8	98	6.2	15.7	93	6.9	13.4	87	8.0	10.9	81	9.0	9.0
	157	55	118	5.4	21.8	112	5.9	18.9	107	6.4	16.7	102	7.1	14.4	96	8.1	11.8	90	9.2	9.8
YC120	108	35	102	6.5	15.8	95	7.3	13.1	89	8.0	11.1	84	9.0	9.3	78	10.3	7.6	73	11.4	6.4
	120	40	120	6.6	18.1	111	7.4	15.1	104	8.2	12.8	97	9.1	10.6	90	10.4	8.7	84	11.5	7.3
	131	45	138	6.7	20.4	128	7.5	17.1	119	8.3	14.4	110	9.3	11.9	102	10.5	9.7	94	11.6	8.1
	143	50	155	6.9	22.6	145	7.6	19.0	134	8.4	16.0	123	9.4	13.2	114	10.6	10.8	105	11.7	8.9
	157	55	173	7.0	24.7	161	7.7	20.8	149	8.5	17.5	136	9.5	14.4	126	10.7	11.8	115	11.8	9.7
YD120	108	35	106	6.4	16.3	96	7.2	13.4	88	7.9	11.2	82	8.8	9.3	73	9.8	7.5	65	11.1	5.9
	120	40	120	6.5	18.4	111	7.3	15.2	103	8.0	12.8	95	9.0	10.5	85	10.0	8.5	78	11.3	6.9
	131	45	136	6.7	20.5	126	7.4	17.0	117	8.2	14.3	108	9.1	11.8	97	10.2	9.5	90	11.5	7.9
	143	50	152	6.8	22.5	142	7.5	18.7	132	8.3	15.8	120	9.3	13.0	109	10.4	10.5	103	11.6	8.8
	157	55	168	6.9	24.4	157	7.7	20.4	146	8.5	17.2	133	9.4	14.1	121	10.6	11.4	115	11.8	9.8
YC150	108	35	190	8.2	23.2	190	9.1	20.8	113	9.8	11.5	105	11.1	9.5	102	12.4	8.2	98	13.8	7.1
	120	40	190	8.5	22.4	190	9.4	20.3	127	10.1	12.6	118	11.3	10.4	113	12.6	8.9	108	14.1	7.7
	131	45	190	8.8	21.7	190	9.6	19.8	140	10.3	13.6	131	11.5	11.3	123	12.8	9.6	118	14.4	8.2
	143	50	190	9.1	21.0	190	9.8	19.3	154	10.6	14.5	144	11.8	12.2	134	13.0	10.3	127	14.6	8.7
	157	55	190	9.3	20.3	190	10.1	18.9	168	10.9	15.4	156	12.0	13.0	145	13.2	10.9	137	14.9	9.2
YD150	108	35	132	8.4	15.7	124	9.2	13.5	119	9.9	11.9	109	11.0	9.9	103	12.4	8.3	94	13.6	6.9
	120	40	149	8.6	17.4	140	9.4	14.9	133	10.2	13.1	123	11.2	10.9	116	12.7	9.1	107	13.9	7.7
	131	45	166	8.7	19.0	156	9.6	16.3	148	10.4	14.2	136	11.5	11.8	128	13.0	9.9	119	14.3	8.3
	143	50	183	8.9	20.5	173	9.8	17.6	163	10.7	15.2	149	11.7	12.7	141	13.3	10.6	131	14.6	9.0
	157	55	200	9.1	21.9	189	10.0	18.8	177	10.9	16.2	163	12.0	13.6	153	13.5	11.3	144	14.9	9.6
YC180	108	35	169	9.7	17.4	153	10.8	14.3	135	11.5	11.7	125	12.7	9.8	116	14.5	8.0	104	16.0	6.5
	120	40	184	10.1	18.2	170	11.0	15.4	154	11.9	13.0	142	13.0	10.9	133	14.8	9.0	121	16.4	7.4
	131	45	198	10.4	19.1	186	11.3	16.4	172	12.2	14.1	160	13.4	12.0	149	15.1	9.9	137	16.7	8.2
	143	50	213	10.7	19.8	203	11.6	17.5	191	12.6	15.2	178	13.7	13.0	166	15.4	10.7	153	17.0	9.0
	157	55	227	11.0	20.6	219	11.9	18.4	210	12.9	16.2	196	14.0	14.0	182	15.7	11.6	169	17.3	9.8
YD180	108	35	160	10.1	15.9	149	11.0	13.6	141	11.6	12.2	136	12.8	10.6	127	14.5	8.8	121	16.3	7.4
	120	40	179	10.2	17.6	168	11.2	15.0	158	11.9	13.3	151	13.1	11.5	141	14.8	9.5	133	16.6	8.0
	131	45	199	10.3	19.2	186	11.3	16.5	175	12.2	14.4	166	13.4	12.3	154	15.1	10.2	145	16.8	8.6
	143	50	218	10.5	20.8	205	11.5	17.8	192	12.5	15.4	180	13.8	13.1	168	15.4	10.9	157	17.1	9.2
	157	55	238	10.6	22.4	224	11.7	19.2	209	12.8	16.4	195	14.1	13.9	181	15.7	11.5	169	17.4	9.7
YC240	108	35	215	12.5	17.2	200	13.6	14.7	185	14.8	12.5	171	16.3	10.5	155	18.2	8.5	139	19.7	7.0
	120	40	244	13.1	18.7	228	14.2	16.1	213	15.3	13.9	197	16.9	11.7	180	18.8	9.6	163	20.5	7.9
	131	45	274	13.6	20.1	257	14.8	17.4	240	15.9	15.2	223	17.4	12.8	204	19.4	10.5	186	21.2	8.8
	143	50	303	14.2	21.4	286	15.4	18.6	268	16.4	16.4	249	18.0	13.8	229	20.0	11.4	210	21.9	9.6
	157	55	332	14.8	22.5	315	15.9	19.7	296	17.0	17.5	275	18.6	14.8	253	20.6	12.3	233	22.6	10.3
YD240	108	35	210	12.4	17.0	196	13.6	14.3	184	15.1	12.2	173	16.7	10.4	157	18.9	8.3	137	21.2	6.5
	120	40	237	12.7	18.6	221	14.0	15.8	208	15.4	13.5	195	17.0	11.5	179	19.2	9.4	161	21.4	7.5
	131	45	264	13.1	20.1	247	14.3	17.3	231	15.7	14.8	217	17.3	12.6	201	19.5	10.3	184	21.7	8.5
	143	50	291	13.5	21.6	273	14.7	18.6	255	15.9	16.0	239	17.6	13.6	223	19.8	11.3	207	22.0	9.4
	157	55	317	13.8	22.9	299	15.0	19.9	279	16.2	17.2	261	17.9	14.6	245	20.1	12.2	230	22.3	10.4

Sound Performance

Outdoor Sound Power Levels (dB), 60 Hz

Size (Tons)	Model	Sound Rating ¹	Octave Bands (Hz)							
			63	125	250	500	1000	2000	4000	8000
090 (7.5)	PC090	89	88	90	89	87	84	81	77	72
	YC090	89	88	89	89	87	84	81	78	73
120 (10.0)	PC120	89	88	90	89	87	84	81	77	72
	YC120	90	91	87	90	88	85	80	76	70
	YD120	90	92	89	91	88	85	80	77	71
150 (12.5)	YC150	91	96	88	90	89	86	82	77	71
	YD150	91	92	92	92	89	86	81	78	73
180 (15.0)	PC180	93	93	96	93	90	89	84	77	71
	PD180	93	93	96	93	90	89	84	77	71
	YC180	89	88	90	89	87	84	81	77	72
	YD180	89	88	90	89	87	84	81	77	72
240 (20.0)	PC240	93	93	96	93	90	89	84	77	71
	PD240	93	93	96	93	90	89	84	77	71
	YC240	93	93	96	93	90	89	84	77	71
	YD240	93	93	96	93	90	89	84	77	71

¹ Rated in accordance with ARI 270 Standard.

Electrical Data

Electrical Data For Outdoor Models

Electrical Data - Outdoor Unit - AC Without Powered Convenience Outlet

Model	Compressors					Outdoor Fan Motor		Pwr Conv Outlet	Minimum Circuit Ampacity ¹	Maximum Fuse Size (A) ²
	Power Supply	Qty.	RLA (each)	MCC (each)	LRA (each)	Qty	FLA (each)	FLA		
YC090	208/230-3-60	1	25.0	39	164	2	2.1	0.0	35.5	45
	460-3-60	1	12.2	19	100	2	1.2	0.0	17.6	25
	575-3-60	1	9.0	14	78	2	0.9	0.0	13.1	20
YC120	208/230-3-60	2	15.6	24	110	2	3.0	0.0	41.2	50
	460-3-60	2	7.8	12	52	2	1.6	0.0	20.8	25
	575-3-60	2	5.8	9	39	2	1.4	0.0	15.8	20
YD120	208/230-3-60	2	17.3	27	123	2	3.0	0.0	45.0	60
	460-3-60	2	9.6	15	70	2	1.6	0.0	24.8	30
	575-3-60	2	7.7	12	53	2	1.4	0.0	20.0	25
YC150	208/230-3-60	2	22.4	35	149	2	3.0	0.0	56.5	70
	460-3-60	2	10.6	17	75	2	1.6	0.0	27.1	35
	575-3-60	2	7.7	12	54	2	1.4	0.0	20.0	25
YD150	208/230-3-60	2	23.1	36	160	2	3.0	0.0	58.0	80
	460-3-60	2	12.2	19	87	2	1.6	0.0	30.7	40
	575-3-60	2	8.7	14	62	2	1.4	0.0	22.3	30
YC180	208/230-3-60	2	25.0	39	164	4	2.1	0.0	64.7	80
	460-3-60	2	12.2	19	100	4	1.2	0.0	32.2	40
	575-3-60	2	9.0	14	78	4	0.9	0.0	24.0	30
YD180	208/230-3-60	2	25.0	39	164	4	2.1	0.0	64.7	80
	460-3-60	2	12.2	19	100	4	1.2	0.0	32.2	40
	575-3-60	2	9.0	14	78	4	0.9	0.0	24.0	30
YC240	208/230-3-60	2	30.1	47	225	4	3.0	0.0	79.8	100
	460-3-60	2	16.7	26	114	4	1.6	0.0	44.0	60
	575-3-60	2	12.2	19	80	4	1.4	0.0	32.9	45
YD240	208/230-3-60	2	30.1	47	225	4	3.0	0.0	79.8	100
	460-3-60	2	16.7	26	114	4	1.6	0.0	44.0	60
	575-3-60	2	12.2	19	80	4	1.4	0.0	32.9	45

¹ Based on three, 75°C insulated copper conductors in conduit and ambient of 30°C.

² Maximum fuse or maximum circuit breaker (HACR type per NEC).
Refer to NEC/NFPA No. 70, Articles 440-11, 12 for information on minimum disconnect sizing.

Electrical Data - Outdoor Unit - AC With Powered Convenience Outlet

Model	Compressors					Outdoor Fan Motor		Pwr Conv Outlet	Minimum Circuit Ampacity ¹	Maximum Fuse Size (A) ²
	Power Supply	Qty.	RLA (each)	MCC (each)	LRA (each)	Qty	FLA (each)	FLA		
YC090	208/230-3-60	1	25.0	39	164	2	2.1	10.0	45.5	60
	460-3-60	1	12.2	19	100	2	1.2	5.0	22.6	30
	575-3-60	1	9.0	14	78	2	0.9	4.0	17.1	25
YC120	208/230-3-60	2	15.6	24	110	2	3.0	10.0	51.2	60
	460-3-60	2	7.8	12	52	2	1.6	5.0	25.8	30
	575-3-60	2	5.8	9	39	2	1.4	4.0	19.8	25
YD120	208/230-3-60	2	17.3	27	123	2	3.0	10.0	55.0	70
	460-3-60	2	9.6	15	70	2	1.6	5.0	29.8	35
	575-3-60	2	7.7	12	53	2	1.4	4.0	24.0	30
YC150	208/230-3-60	2	22.4	35	149	2	3.0	10.0	66.5	80
	460-3-60	2	10.6	17	75	2	1.6	5.0	32.1	40
	575-3-60	2	7.7	12	54	2	1.4	4.0	24.0	30
YD150	208/230-3-60	2	23.1	36	160	2	3.0	10.0	68.0	90
	460-3-60	2	12.2	19	87	2	1.6	5.0	35.7	45
	575-3-60	2	8.7	14	62	2	1.4	4.0	26.3	30
YC180	208/230-3-60	2	25.0	39	164	4	2.1	10.0	74.7	90
	460-3-60	2	12.2	19	100	4	1.2	5.0	37.2	45
	575-3-60	2	9.0	14	78	4	0.9	4.0	28.0	35
YD180	208/230-3-60	2	25.0	39	164	4	2.1	10.0	74.7	90
	460-3-60	2	12.2	19	100	4	1.2	5.0	37.2	45
	575-3-60	2	9.0	14	78	4	0.9	4.0	28.0	35
YC240	208/230-3-60	2	30.1	47	225	4	3.0	10.0	89.8	110
	460-3-60	2	16.7	26	114	4	1.6	5.0	49.0	60
	575-3-60	2	12.2	19	80	4	1.4	4.0	36.9	45
YD240	208/230-3-60	2	30.1	47	225	4	3.0	10.0	89.8	110
	460-3-60	2	16.7	26	114	4	1.6	5.0	49.0	60
	575-3-60	2	12.2	19	80	4	1.4	4.0	36.9	45

¹ Based on three, 75°C insulated copper conductors in conduit and ambient of 30°C.

² Maximum fuse or maximum circuit breaker (HACR type per NEC).
Refer to NEC/NFPA No. 70, Articles 440-11, 12 for information on minimum disconnect sizing.

Typical Wiring Diagrams

Air Conditioning Condensing Units

Typical YC090 Wiring Diagram

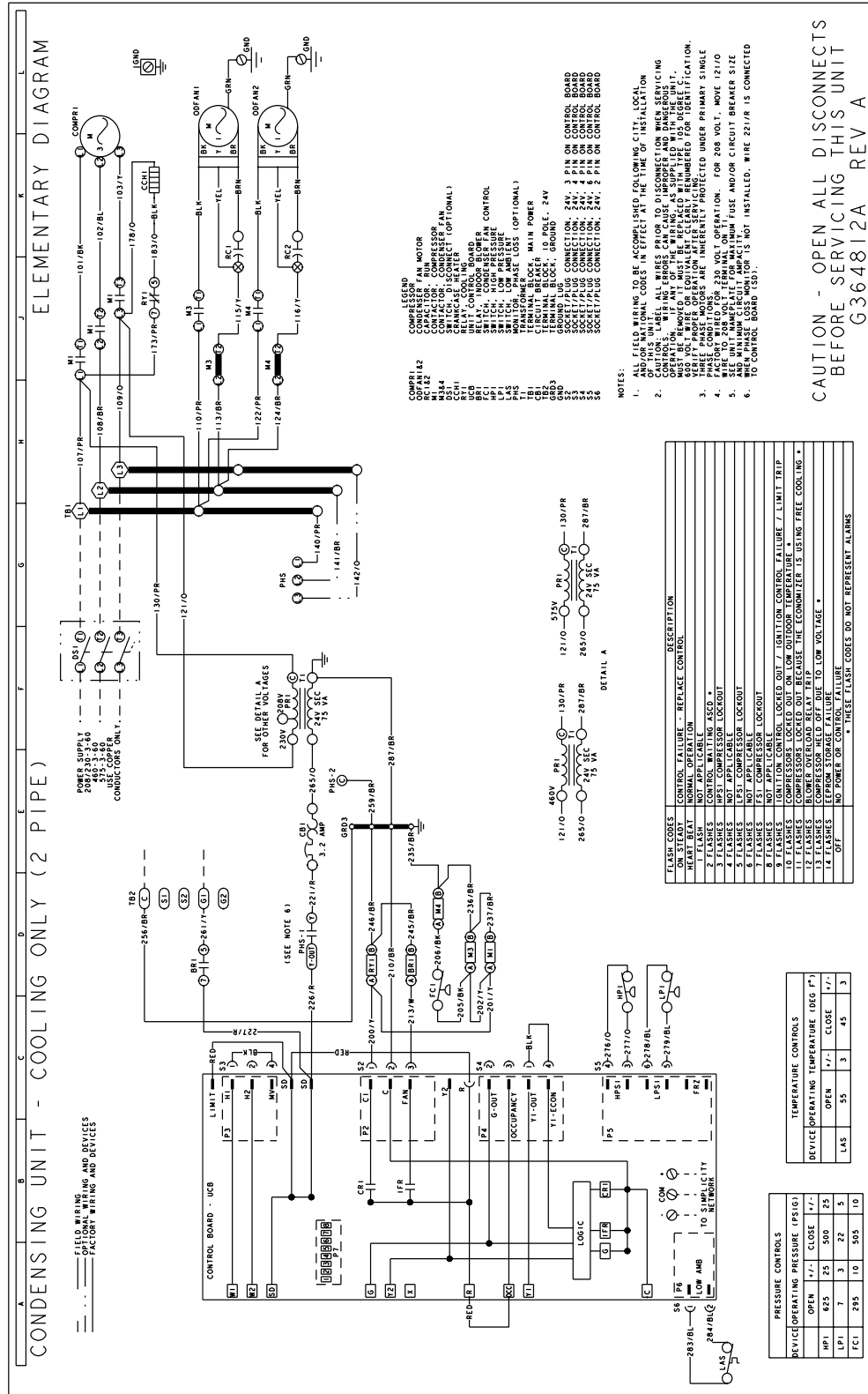

Typical YC120 - 150 Wiring Diagram

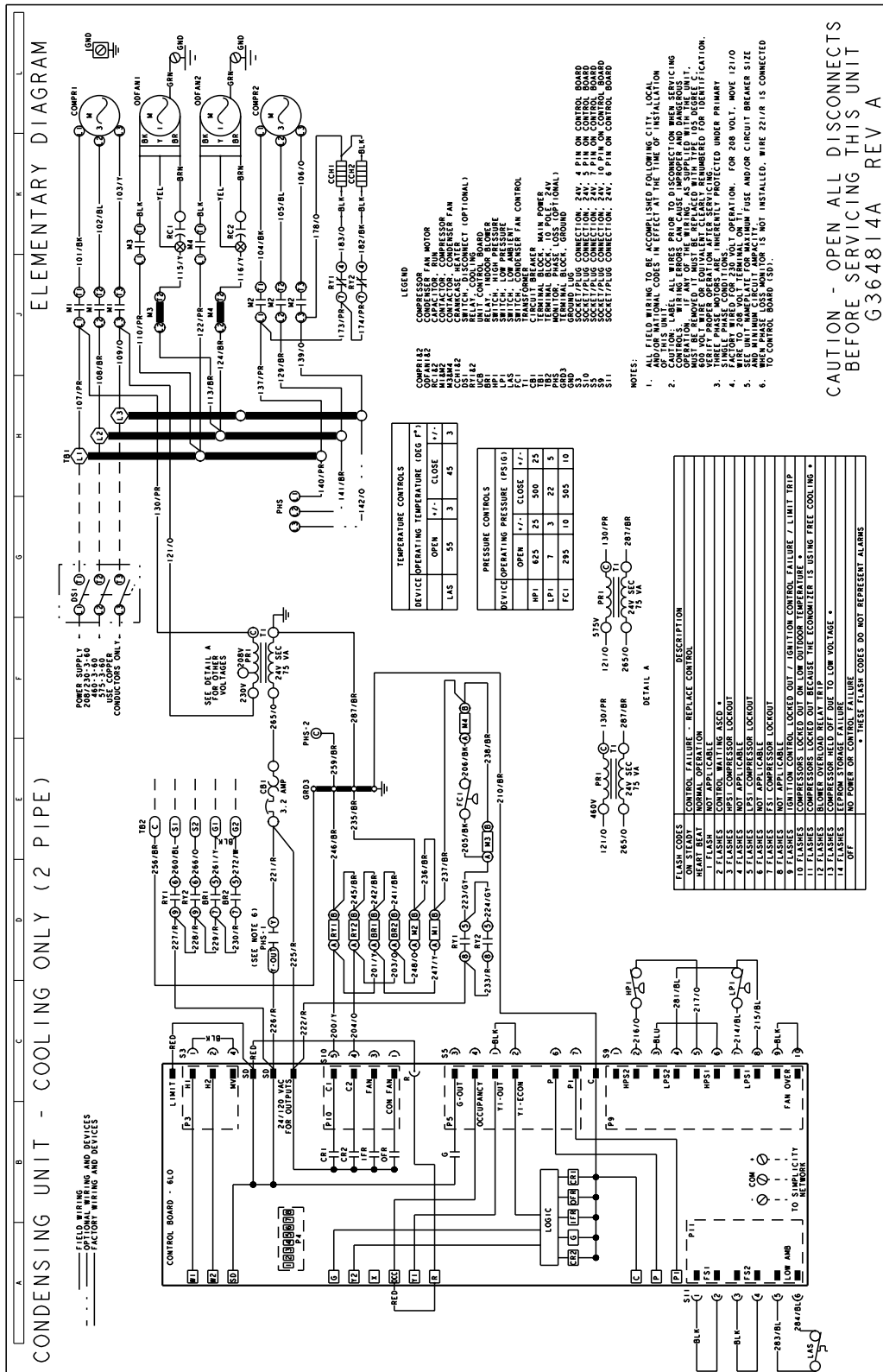

Typical YC180 - 240 Wiring Diagram

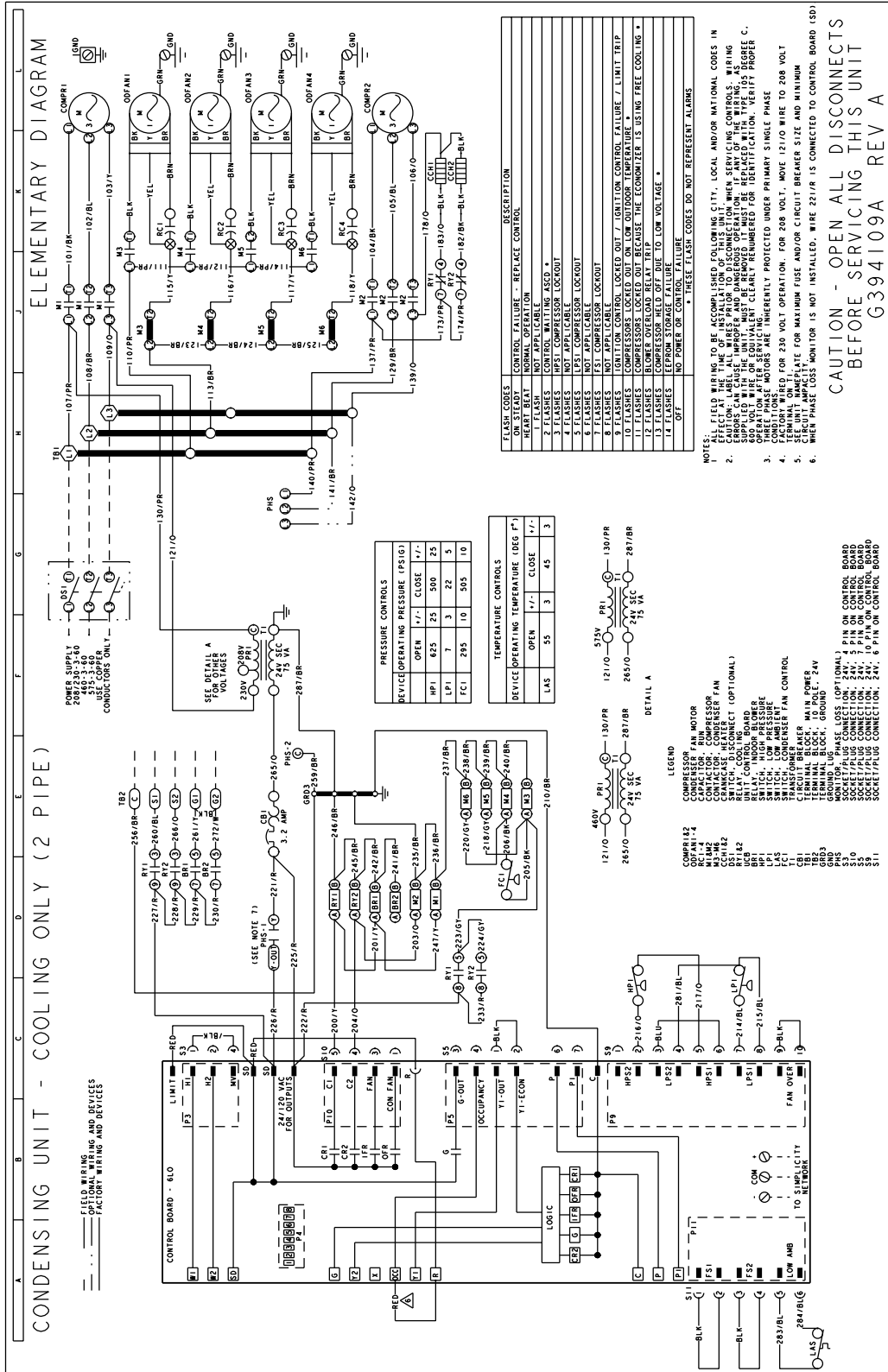

Weights And Dimensions

Corner Weights & Center of Gravity AC/HP Units

Model	Weight (lbs.)		Center of Gravity (in.)		4 Point Load Location (lbs.)			
	Shipping	Operating	X	Y	A	B	C	D
PC090	405	415	16	32.5	114	114	94	93
PC120	550	560	17.5	32.9	141	171	136	112
PC180	815	840	32.5	33	231	238	188	183
PD180	810	835	34	32.5	216	244	199	176
PC240	985	1010	31	32.5	287	269	220	235
PD240	980	1005	30.5	31.5	281	255	223	246
YC090	330	325	18.5	30.8	71	98	90	65
YC120	450	445	18	34	112	144	107	82
YD120	445	440	16.5	33.5	120	129	99	92
YC150	450	445	18	34	112	144	107	82
YD150	445	440	16.5	33.5	120	129	99	92
YC180	680	675	32.5	31.5	177	182	160	155
YD180	680	675	32.5	31.5	177	182	160	155
YC240	710	710	32	37	223	222	133	133
YD240	710	710	32	37	223	222	133	133

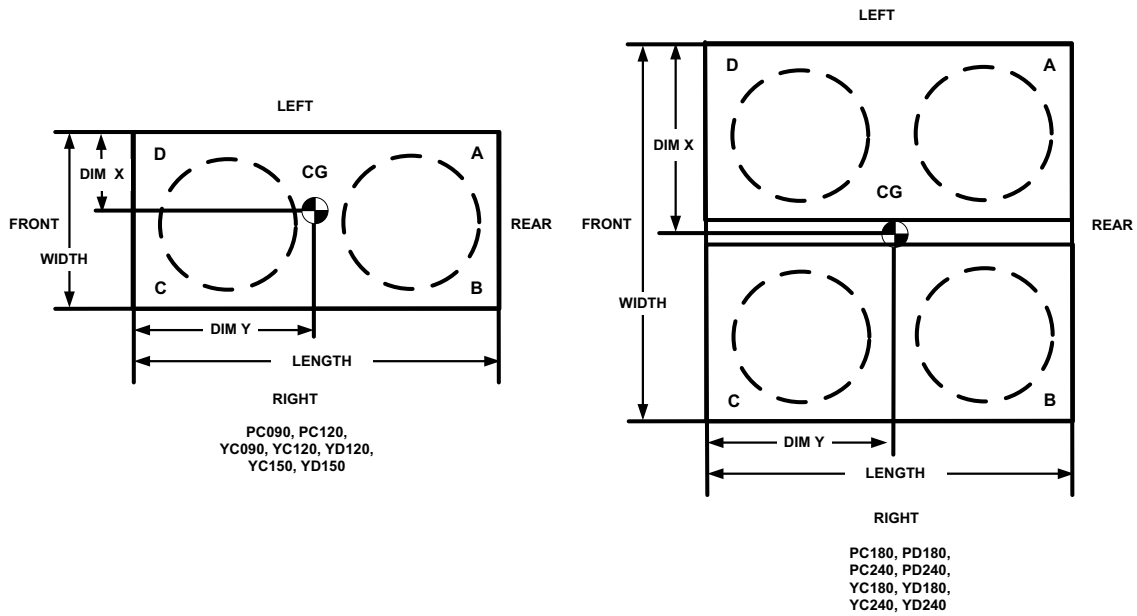

NOTE: Front of unit is considered the side having the unit control box.

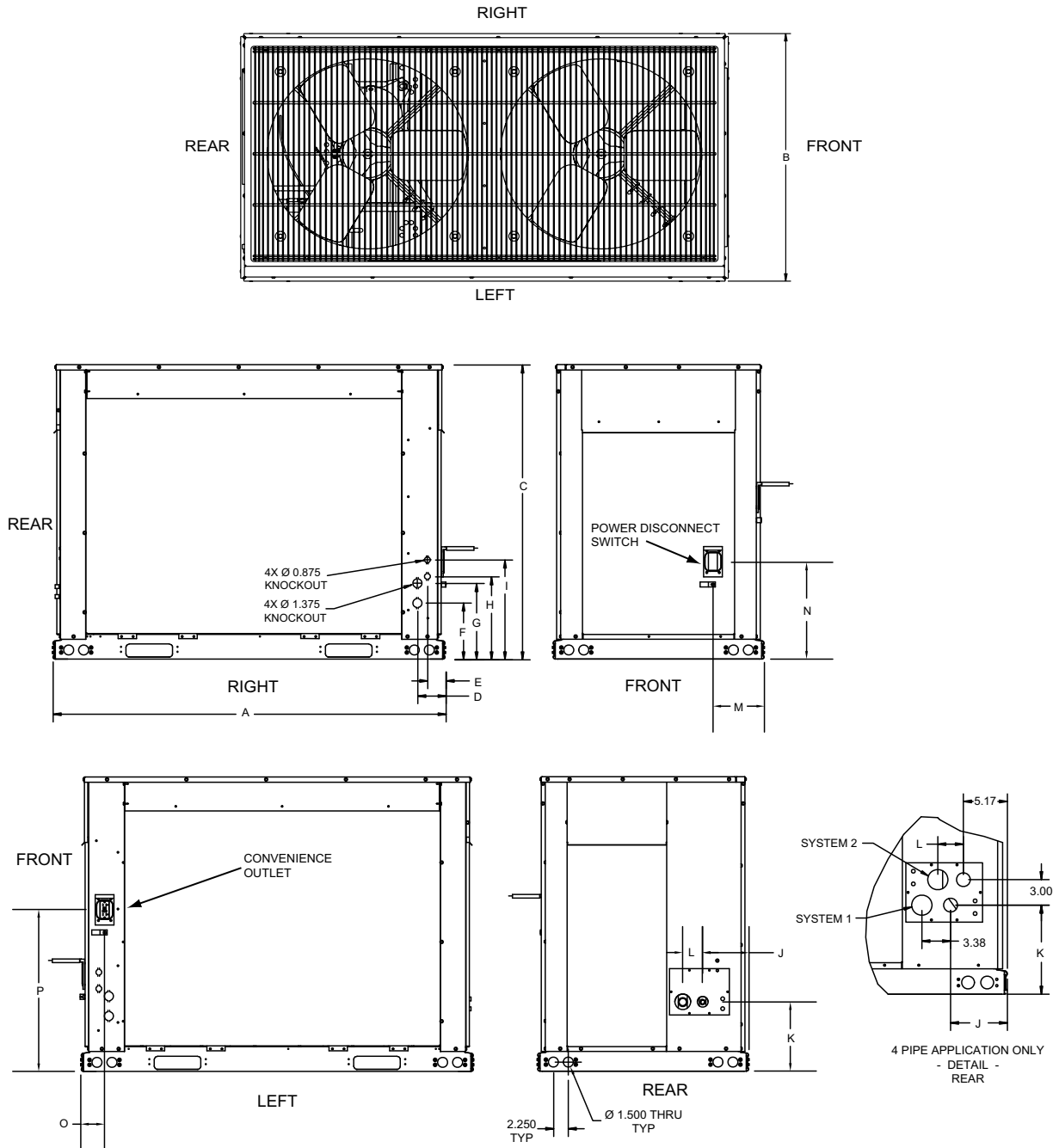

Unit Dimensions PC090, PC120, YC090, YC/YD120, YC/YD150

Unit Dimensions

MODEL	A	B	C	D	E	F	G	H	I	J	K	L	M	N	O	P
PC090	59.1	31.9	44.5	4.2	2.7	8.5	11.4	12.4	14.9	6.9	10.5	3.0	7.7	14.7	3.3	24.5
PC120	59.1	31.9	50.0	4.2	2.7	8.5	11.4	12.4	14.9	6.9	10.5	3.0	7.7	14.7	3.3	24.5
YC090	59.1	31.9	44.5	4.2	2.7	8.5	11.4	12.4	14.9	6.9	10.5	3.0	7.7	14.7	3.3	24.5
YC120	59.1	31.9	50.0	4.2	2.7	8.5	11.4	12.4	14.9	6.9	10.5	3.0	7.7	14.7	3.3	24.5
YD120	59.1	31.9	50.0	4.2	2.7	8.5	11.4	12.4	14.9	6.9	10.5	3.0	7.7	14.7	3.3	24.5
YC150	59.1	31.9	50.0	4.2	2.7	8.5	11.4	12.4	14.9	6.9	10.5	3.0	7.7	14.7	3.3	24.5
YD150	59.1	31.9	50.0	4.2	2.7	8.5	11.4	12.4	14.9	6.9	10.5	3.0	7.7	14.7	3.3	24.5

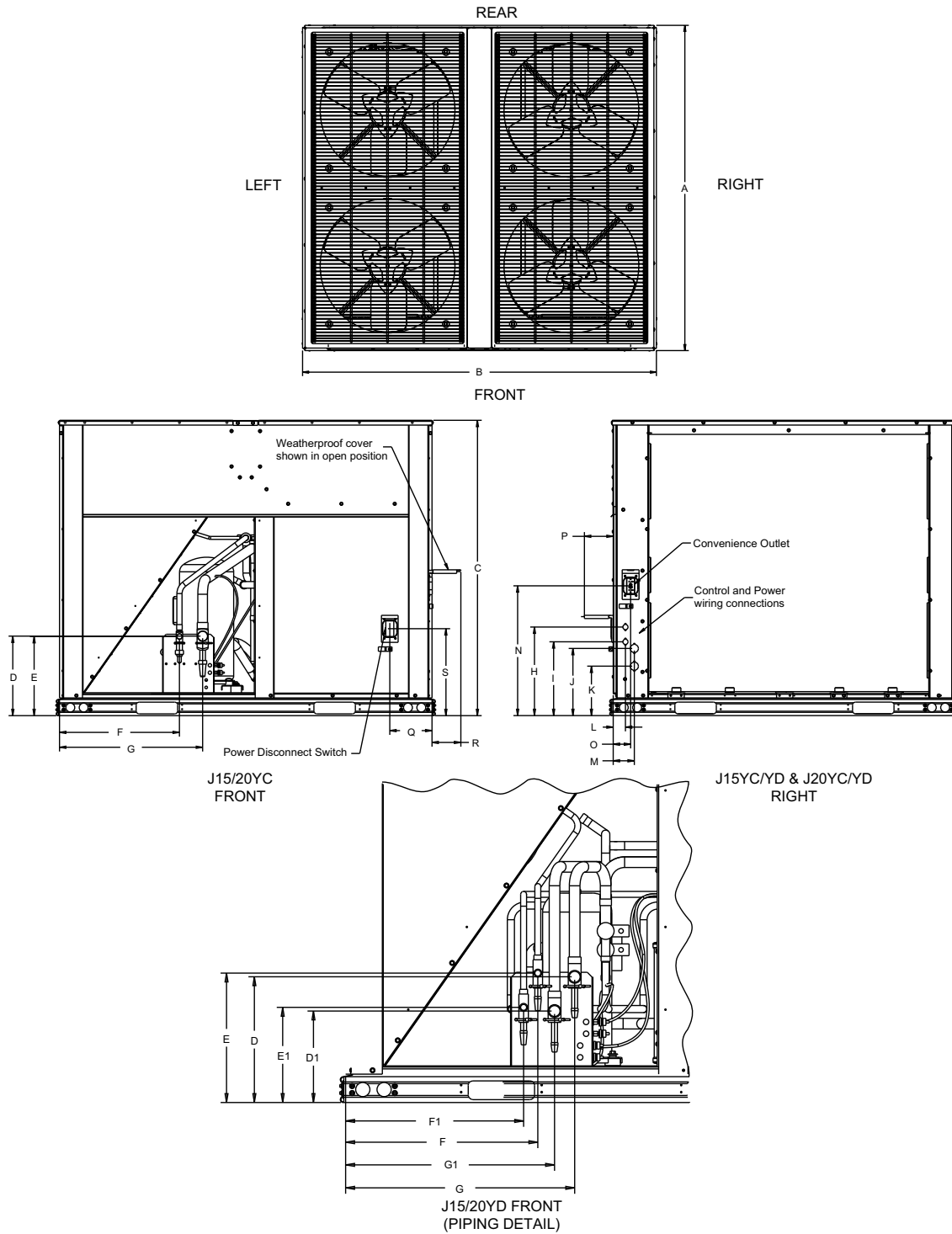

Unit Dimensions PC/PD180, PC/PD240, YC/YD180, YC/YD240

Unit Dimensions

MODEL	A	B	C	D	DI	E	EI	F	FI	G	GI	H	I	J	K	L	M	N	O	P	Q	R	S
PC180	59.1	64.1	44.5	13.8	N/A	13.4	N/A	20.2	N/A	23.9	N/A	15.0	12.5	11.4	8.4	2.4	3.9	22.0	2.9	4.9	7.1	4.8	14.7
PD180	59.1	64.1	44.5	13.7	10.1	13.3	9.7	10.3	18.8	24.2	22.0	15.0	12.5	11.4	8.4	2.1	3.6	22.0	2.9	4.9	7.1	4.8	14.7
PC240	59.1	64.1	50.0	13.8	N/A	13.4	N/A	20.2	N/A	23.9	N/A	15.0	12.5	11.4	8.4	2.1	3.6	22.0	2.9	4.9	7.1	4.8	14.7
PD240	59.1	64.1	50.0	14.0	10.5	13.5	9.9	20.3	18.8	24.1	22.0	15.0	12.5	11.4	8.4	2.1	3.6	22.0	2.9	4.9	7.1	4.8	14.7
YC180	59.1	64.1	44.5	13.4	N/A	13.4	N/A	20.2	N/A	24.1	N/A	15.0	12.5	11.4	8.4	2.1	3.6	22.0	2.9	4.9	7.1	4.8	14.7
YD180	59.1	64.1	44.5	13.1	9.6	12.9	9.4	20.2	18.7	24.2	22.0	15.0	12.5	11.4	8.4	2.1	3.6	22.0	2.9	4.9	7.1	4.8	14.7
YC240	59.1	64.1	50.0	13.5	N/A	13.4	N/A	20.2	N/A	24.2	N/A	15.0	12.5	11.4	8.4	2.1	3.6	22.0	2.9	4.9	7.1	4.8	14.7
YD240	59.1	64.1	50.0	13.1	9.6	12.9	9.4	20.2	18.7	24.2	22.0	15.0	12.5	11.4	8.4	2.1	3.6	22.0	2.9	4.9	7.1	4.8	14.7

NOTE: The 'I' designation indicates a four pipe system.

PIPING AND ELECTRICAL CONNECTIONS

Piping connections are made from the rear of 7.5 thru 12.5 Ton units and the front of 15 thru 20 Ton units. Connections can be made directly to the suction and liquid line service valves.

With the piping connections being made at the rear of 7.5 thru 12.5 Ton units and the front of 15 thru 20 Ton units, the piping can be routed to the units from the left or right side.

Electrical connections for power and control wiring are made from the front of the units, right or left of 7.5 thru 12.5 Ton electrical control box access or left of the electrical control box access on 15 thru 20 Ton units. See Unit Dimensions

and Piping and Electrical Connection Sizes tables for piping sizes and electrical knockout details.

UNIT CLEARANCES

Location	Dimensions
Overhead (Top) ¹	120"
Front access panels	36"
Left Side	30"
Right Side	30"
Rear	24"
Bottom ²	0"

¹ Units must be installed outdoors. Overhanging structures or shrubs should not obstruct condenser air discharge.

Piping And Electrical Connection Sizes (Inches)

MODEL	PC090	YC090	PC120	YC120	YD120	YC150	YD150
No. Refrigeration Circuits	1	1	1	1	2	1	2
Suction Line OD (in.)	1 1/8	1 1/8	1 1/8	1 3/8	1 1/8	1 3/8	1 1/8
Liquid Line OD (in.)	5/8	5/8	5/8	7/8	5/8	7/8	5/8
Power Wiring Knockout	1 3/8	1 3/8	1 3/8	1 3/8	1 3/8	1 3/8	1 3/8
Control Wiring Knockout	7/8	7/8	7/8	7/8	7/8	7/8	7/8

MODEL	PC180	PD180	PC240	PD240	YC180	YD180	YC240	YD240
No. Refrigeration Circuits	1	2	1	2	1	2	1	2
Suction Line OD (in.)	1 5/8	1 1/8	1 5/8	1 3/8	1 5/8	1 1/8	1 5/8	1 3/8
Liquid Line OD (in.)	7/8	5/8	7/8	7/8	7/8	5/8	7/8	7/8
Power Wiring Knockout	1 3/8	1 3/8	1 3/8	1 3/8	1 3/8	1 3/8	1 3/8	1 3/8
Control Wiring Knockout	7/8	7/8	7/8	7/8	7/8	7/8	7/8	7/8