

REZTOR[®]
MODEL F

ANSI Z83.8



CAN/CGA 2.6

**Gas-Fires, Gravity-Vented,
Fan-Type Unit Heater for
Commercial/Industrial Use**

WARNING: Gas-fired appliances are not designed for use in hazardous atmospheres containing flammable vapors or combustible dust, or atmospheres containing chlorinated or halogenated hydrocarbons.

Installations in public garages or airplane hangars are permitted when in accordance with ANSI Z223.1 and NFPA 54 Codes or CAN1-B149 Codes and enforcing authorities.

DESCRIPTION

Reznor[®] Series 100, Model F gas-fired, gravity-vented unit heaters are designed for 80% thermal efficiency and are designed for use with natural or propane gas, as specified, in sizes from 25,000 to 400,000 BTUH gas input.

Model F unit heaters are designed for ceiling suspension with a propeller fan for air delivery.

A terminal strip connector facilitates field connection to a remote 24-volt thermostat for automatic operation. Each unit is provided with a fan control and all required limit safety controls, including an energy cutoff (ECO) device and a blocked vent switch.

These units are approved for installation in The United States and Canada by the Canadian Standards Association (CSA).

NOTE: When installing gravity vented appliances check local and state codes for requirements. Some states require the addition of spark pilot Option AH2 or AH3.

STANDARD FEATURES

- Orifices for natural gas
- Aluminized steel heat exchanger
- Aluminized steel burner rack with stainless steel insert
- Spark ignited, intermittent safety pilot with electronic flame supervision
- Single-stage combination gas valve (field adjustable for high altitude operation)
- 115/1/60 supply voltage
- 115 volt fan motor with internal overload protection
- Fan and limit safety controls
- Energy cutoff (ECO) device
- Blocked vent shutoff system
- 24-volt control voltage transformer
- Individually adjustable horizontal louvers
- Full safety fan guard
- Terminal strip connector for 24-volt field wiring
- Convenient bottom burner access
- 2-point 3/8"-16 threaded hanger connections
- Horizontal/vertical vent outlet

**OPTIONAL FEATURES -
FACTORY INSTALLED**

- Equipped for propane gas
- E-3 (409) stainless steel heat exchanger and burner
- Two-stage gas control (50% low fire) - Sizes 75-400
- Spark ignited, intermittent safety pilot with electronic flame supervision with timed lockout (timed lockout is required for propane gas)
- Manual summer/winter switch
- Burner air shutters
- 208/230 single phase supply voltage
- 220/240 volt/50 Hertz electrical operation
- Totally enclosed 115V motor
- Low ambient fan control relay

**OPTIONAL FEATURES -
FIELD INSTALLED**

- Power venter
- Vertical louvers
- Downturn air nozzle, 25-65° or 50-90° variable air deflector range (includes 4-point suspension kit)
- Thermostat and relay kits
- Air recirculation kits
- Manual summer/winter switch
- Multiple heater control
- 4-point suspension kit
- Unit-mounted thermostat bracket
- Step down transformer 230/115 or 460/115
- Burner air shutters
- Low ambient fan control relay kit
- Hanger kit to suspend from 1" pipe (2 or 4 point suspension)
- Single-stage and two-stage thermostats
- Thermostat guard with locking cover
- Manual shutoff valve and union
- Gas conversion kit

NOTE: Not certified for residential use.

The Energy Policy Act of 2005 mandated that beginning August of 2008, no Gravity Vented Unit Heaters may be sold without an Intermittent Ignition Device (No Standing Pilot- Spark Ignition Only) AND, (either an automatic shutoff vent damper or a power vent exhaust). Your state may have already enacted this restriction in their local codes. Please take note of this when placing orders for gravity vented units.

NOTE: Regulated combination redundant gas valve consists of combination pilot solenoid valve, electric gas valve, pilot filter, pressure regulator, pilot shutoff, and manual shutoff, all in one body. Gas supply pressure must not exceed 0.5 psi (8 oz. or 14" w.c.). Minimum inlet pressure for natural gas is 5" w.c.; minimum inlet pressure for propane gas is 11" w.c.

TECHNICAL DATA

Model F

Size	25		50		75		100		125	
Heating Input - BTUH (kW)	25,000	(7.3)	50,000	(14.7)	75,000	(22.0)	100,000	(29.3)	125,000	(36.6)
Thermal Output - BTUH (kw) (80%) ^A	20,000	(5.9)	40,000	(11.7)	60,000	(17.6)	80,000	(23.4)	100,000	(29.3)
Vent Outlet Diameter	4" Rd		4" Rd		5" Oval		6" Oval		7" Oval	
Gas Connection - Natural Gas ^B	1/2"		1/2"		1/2"		1/2"		1/2"	
Control Amps (24-volt)	0.33		0.33		0.33		0.33		0.33	
Full-Load Amps (115 volt)	0.8		1.3		1.9		2.8		2.9	
Normal Consumption (watts)	60		95		135		195		205	
Throw at 8' (2.4M) Mntg Ht - ft (M) ^C	35	(11)	39	(12)	48	(15)	60	(18)	73	(22)
Motor HP ^D	Standard		1/50		1/35		1/15		1/30	
	Optional Enclosed		--		1/15		1/15		1/8	
Motor RPM	1550		1550		1550		1050		1050	
Fan Diameter - in. (mm)	10	(254)	10	(254)	12	(305)	14	(356)	16	(406)
Air Volume - CFM (M ³ /hr)	380	(646)	650	(1,104)	980	(1,665)	1,250	(2,124)	1,600	(2,718)
Outlet Velocity - FPM (M/s)	423	(2.1)	853	(4.3)	1,166	(5.9)	1,358	(6.9)	1,330	(6.8)
Approximate Net Wt - lbs (kg)	72	(33)	79	(36)	88	(40)	97	(44)	127	(58)
Approximate Shipping Wt - lbs (kg)	89	(40)	96	(44)	107	(49)	118	(54)	150	(68)

Size	165		200		250		300		400	
Heating Input - BTUH (kW)	165,000	(48.4)	200,000	(58.6)	250,000	(73.3)	300,000	(87.9)	400,000	(117.2)
Thermal Output - BTUH (kw) (80%) ^A	132,000	(38.7)	160,000	(46.9)	200,000	(58.6)	240,000	(70.3)	320,000	(93.8)
Vent Outlet Diameter	8" Oval		8" Oval		10" Oval		10" Oval		12" Oval	
Gas Connection - Natural Gas ^B	1/2"		1/2"		1/2"		3/4"		3/4"	
Control Amps (24-volt)	0.23		0.23		0.23		0.2		0.2	
Full-Load Amps (115 volt)	4		4		2.5		4		7	
Normal Consumption (watts)	275		300		280		375		565	
Throw at 8' (2.4M) Mntg Ht - ft (M) ^C	78	(24)	85	(26)	96	(29)	108	(33)	120	(37)
Motor HP ^D	Standard		1/20		1/6		1/4		1/2	
	Optional Enclosed		1/8		1/6		1/2		1/2	
Motor RPM	1050		1050		850		850		850	
Fan Diameter - in. (mm)	16	(406)	20	(508)	22	(559)	22	(559)	24	(610)
Air Volume - CFM (M ³ /hr)	2,200	(3,738)	2,800	(4,757)	3,360	(5,708)	3,800	(6,456)	4,940	(8,393)
Outlet Velocity - FPM (M/s)	1,100	(5.6)	1,217	(6.2)	1,182	(6.0)	1,426	(7.2)	1,420	(7.2)
Approximate Net Wt - lbs (kg)	149	(68)	170	(77)	204	(93)	221	(100)	276	(125)

^A For U.S. installations, ratings for altitudes to 2000 ft. Above 2000 ft., derate by 4% for each 1000 ft. above sea level.

^A For Canadian installations, ratings for altitudes to 2000 ft. High altitude units (2001-4500 ft.) are derated by 10% of maximum input.

^B Gas connection for propane is 1/2" for all sizes. Sizes shown are for gas connection to a single-stage gas valve; NOT gas supply line size.

^C Additional mounting heights shown later in this catalog.

^D All other information in this table is based on a heater equipped with a standard 115v motor. (The standard motor for a Model 25 is an enclosed motor; all other standard motors are open motors. Optional enclosed motors are available in 115v only.)

DIMENSIONS

Model F

±1/16" (2mm)

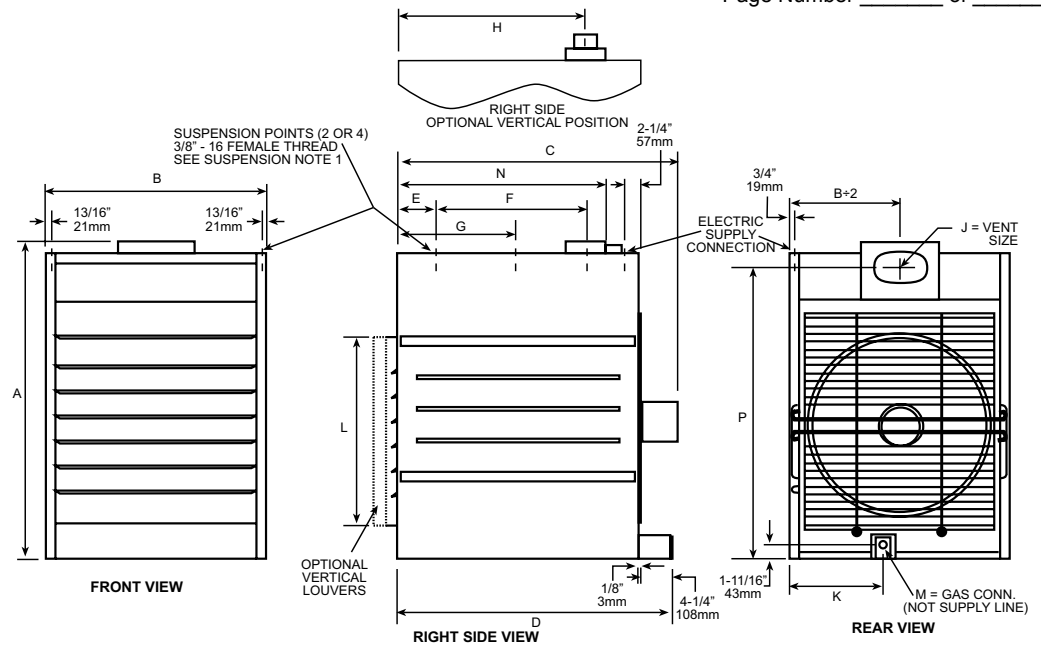

Size		A	B	C	D	E	F	G	H	J	K	L	M - in.		N	P
													Nat	Pro		
25,50	in	30 1/8	13 1/2	27	31 1/2	5 7/8	14 1/2	14	19	4 Rnd	10 1/4	16	1/2	1/2	21 1/2	27 5/8
	(mm)	(765)	(343)	(686)	(800)	(149)	(368)	(356)	(483)	--	(260)	(406)	--	--	(546)	(702)
75	in	30 1/8	15 1/2	27	31 1/2	5 7/8	14 1/2	14	19	5 Oval	10 1/2	16	1/2	1/2	21 1/2	27 5/8
	(mm)	(765)	(394)	(686)	(800)	(149)	(368)	(356)	(483)	--	(267)	(406)	--	--	(546)	(702)
100	in	30 1/8	17 1/2	30 1/2	31 1/2	5 7/8	14 1/2	14	19	6 Oval	12 7/8	16	1/2	1/2	21 1/2	27 5/8
	(mm)	(765)	(445)	(775)	(800)	(149)	(368)	(356)	(483)	--	(327)	(406)	--	--	(546)	(702)
125	in	32	23 1/4	30 1/2	31 1/2	5 7/8	14 1/2	14	19	7 Oval	14 1/2	16	1/2	1/2	21 1/2	28 1/2
	(mm)	(813)	(591)	(775)	(800)	(149)	(368)	(356)	(483)	--	(368)	(406)	--	--	(546)	(724)
165	in	40 1/8	20 1/4	35 1/2	36	4 7/8	19 1/2	15 3/4	23 3/8	8 Oval	14 1/4	24	1/2	1/2	27	36 3/4
	(mm)	(1,019)	(514)	(902)	(914)	(124)	(495)	(400)	(594)	--	(362)	(610)	--	--	(686)	(933)
200	in	40 1/8	23 1/4	36 1/4	36	4 7/8	19 1/2	15 3/4	23 3/8	8 Oval	14 3/8	24	1/2	1/2	27	36 3/4
	(mm)	(1,019)	(591)	(921)	(914)	(124)	(495)	(400)	(594)	--	(365)	(610)	--	--	(686)	(933)
250	in	43 1/2	28 3/4	36 1/4	36	4 7/8	19 1/2	15 3/4	21 3/4	10 Oval	12 3/8	24	1/2	1/2	27	38 3/8
	(mm)	(1,105)	(730)	(921)	(914)	(124)	(495)	(400)	(552)	--	(314)	(610)	--	--	(686)	(975)
300	in	43 1/2	28 3/4	36 3/4	36	4 7/8	19 1/2	15 3/4	21 3/4	10 Oval	12 3/8	24	3/4	1/2	27	38 3/8
	(mm)	(1,105)	(730)	(933)	(914)	(124)	(495)	(400)	(552)	--	(314)	(610)	--	--	(686)	(975)
400	in	43 1/2	37	37 1/4	36	4 7/8	19 1/2	15 3/4	21 3/4	12 Oval	13	24	3/4	1/2	27	38 3/8
	(mm)	(1,105)	(940)	(946)	(914)	(124)	(495)	(400)	(552)	--	(330)	(610)	--	--	(686)	(975)

Units, bottom clearance exceeding 12" minimum is not required but may be desirable.

CLEARANCES FROM COMBUSTIBLES

Required Clearances (inches)

Flue	Top ^E	Connector	Sides	Bottom ^F	Rear ^G
25-125	2	6	18	12	24
165-400	6	6	18	12	24

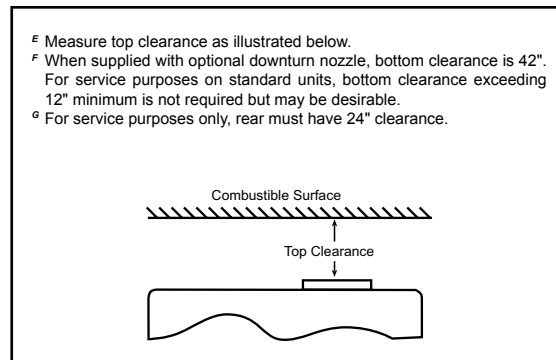

- ^E Measure top clearance as illustrated below.
- ^F When supplied with optional downturn nozzle, bottom clearance is 42". For service purposes on standard units, bottom clearance exceeding 12" minimum is not required but may be desirable.
- ^G For service purposes only, rear must have 24" clearance.

SUSPENSION NOTES:

- 1) Use dimension "G" for 2-point suspension and "E" and "F" for 4-point suspension.
- 2) Factory equipped with 2-point suspension; 4-point is optional.