

# Commercial High-Efficiency Condensing Units

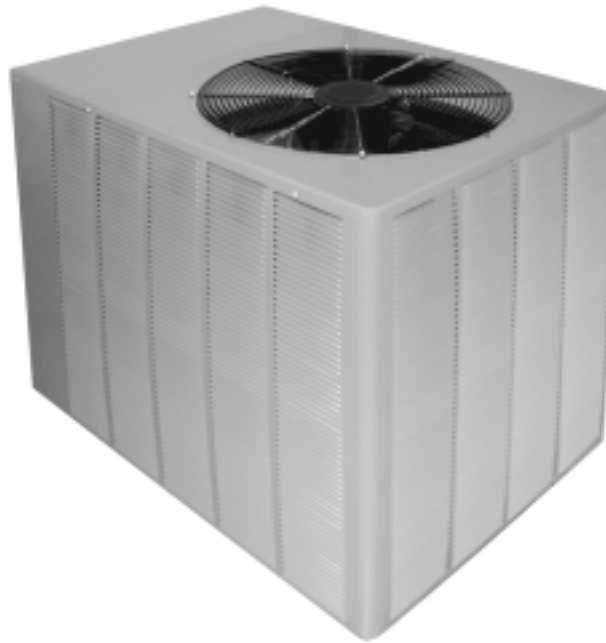

**R-410A**  
*earth friendly refrigerant*



**RAWL-High Efficiency**

**6.5 & 7.5 TON MODEL  
[22.86 & 26.38 kW]**



# TABLE OF CONTENTS

Model Number Designation.....	2	Electrical & Physical Data Table .....	8
Accessories & Standard Unit Features .....	3	Cooling Performance Data .....	9-10
Selection Procedure		Piping .....	11-12
Matched Systems .....	4	Installation .....	12
Gross Capacity and Power Tables .....	5	Wiring Schematic .....	13
Unit Dimensions .....	6	Guide Specifications .....	14
ARI Ratings .....	7	Limited Warranty .....	14

## MODEL IDENTIFICATION

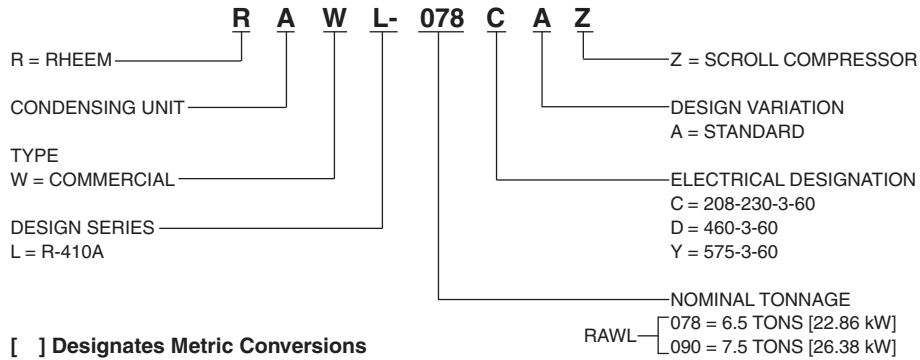

# CONDENSING UNIT ACCESSORIES

ACCESSORY DESCRIPTION	MODEL NUMBER	SIZES USED ON
Anti-Short Cycle Timer Kit	RXAT-A01	RAWL-078, 090
Sight Glass	RXAG-A048	RAWL-078, 090
Liquid Line Solenoid Valve*	RXAV-BD048	RAWL-078, 090

\*May be used as isolation valve only. Do not use as a pump-down solenoid. Refer to system wiring diagram.

## STANDARD UNIT FEATURES

**CABINET**—Galvanized steel with powder coat paint finish. The powder coat paint finish is high gloss, durable and capable of withstanding a 1000-HR salt spray test per ASTM B117. The unit is of the frame and panel type of construction which allows all access panels to be opened or removed without affecting the structural strength of the unit. Fastening screws are also of the 1000-HR type. Stamped louver panels offer 100% protection for the condenser coil.

**BASE PAN**—Galvanized steel with powder coat paint finish.

**SERVICE ACCESS**—Control box with separation between line and control voltages, as well as compressor and other refrigerant controls are accessible through removable panel without affecting normal operation of unit.

**FAN MOTOR**—Condenser fan motor(s) are mounted on removable top panel(s) which bring the motor(s) out to you and expose entire condenser coil for cleaning.

**COMPRESSOR**—The Scroll Compressor is hermetically sealed with internal high temperature protection, and durable insulation on motor windings. The entire compressor is mounted on rubber grommets to reduce vibration and noise. Compressors have an internal pressure relief assembly to protect against excessive pressure differential. There is a separate compressor compartment for easy service access.

**COMPRESSOR CRANKCASE HEATER**—External wrap-around heater helps prevent refrigerant migration to the compressor oil during long off periods.

**CONDENSER COILS**—Constructed with copper tubes and aluminum fins mechanically bonded to tubes for maximum heat transfer capabilities. All coil assemblies are leak tested up to 450 PSIG internal pressure.

**REFRIGERANT CONNECTIONS**—All field sweat joints are made external of the unit and are located close to the ground for a neat looking installation.

**LOW AMBIENT CONTROL**—A pressure sensitive fan cycling control allows operation of units down to 0°F [-18°C].

**HIGH PRESSURE CONTROL**—Manual reset control deactivates system if abnormally high pressure occurs.

**LOW PRESSURE CONTROL**—Automatic reset control deactivates system if abnormally low pressure or refrigerant loss occurs.

**SERVICE VALVES**—Standard on liquid and suction lines.

**CONDENSER FAN MOTORS**—Direct drive, single-phase permanently lubricated “PSC” motors with inherent overload protection.

**TRANSFORMER**—50VA step-down type, from Line to 24 volts.

**CONTACTOR**—The contactor is an electrical switch which operates the compressor and condenser fans. Its 24 volt coil is activated through the High Pressure Control and Low Pressure Control on a call for cooling.

**EQUIPMENT GROUND**—Lug for field connection of ground wire.

**TESTING**—All units are run tested at the factory prior to shipment. Units are shipped with a holding charge of nitrogen.

**CONTROL BOX**—The control box is located in the top corner of the cabinet providing for easy access through a service panel.

**COMPRESSOR TIME DELAY CONTROL**—Compressor will remain off for five minutes after power or thermostat interruption, allowing system pressures to equalize. (Model No. RXMD-B01)

**FILTER/DRIER**—A liquid line filter drier is shipped with each unit for field installation.

[ ] Designates Metric Conversions

## SELECTION PROCEDURE— MATCHED SYSTEMS

Example 1: Determine the Net System Performance of Condensing Unit RAWL-090 with RHGL-090 at 3360 CFM [1586 L/s] @ .30" [.07 kPa] external static pressure, 80°F [27°C] DB/67°F [19°C] WB entering indoor air and 95°F [35°C] DB outdoor ambient.

From Performance Data—Condensing Unit RAWL-090 with Air Handler RHGL-090Z:

$$\begin{aligned}\text{Total Cap. (gross)} &= 95.7 \times 1000 = 95,700 \text{ BTUH [28.04 kW]} \\ \text{Sens. Cap. (gross)} &= 76.2 \times 1000 = 76,200 \text{ BTUH [22.33 kW]} \\ \text{Power (gross)} &= 7.5 \times 1000 = 7,500 \text{ WATTS}\end{aligned}$$

From Commercial Air Handler, Wet Coil Airflow Performance Data:

$$\begin{aligned}\text{Power} &= 1,056 \text{ WATTS} \\ &= 1,056 \times 3.412 = 3,603 \text{ BTUH [1.06 kW]}\end{aligned}$$

Therefore, the Net Performance is:

$$\begin{aligned}\text{Total Cap. (Net)} &= 95,700 - 3,603 = 92,097 \text{ BTUH [27.00 kW]} \\ \text{Sens. Cap (Net)} &= 76,200 - 3,603 = 72,597 \text{ BTUH [21.72 kW]} \\ \text{Power (Net)} &= 7,500 + 1,056 = 8,556 \text{ WATTS} \\ \text{EER} &= 92,097 \div 8,556 = 10.76 \text{ BTUH [3.15 w/w] WATT}\end{aligned}$$

Example 2: Determine the Sensible Net Capacity at 75°F [27°C] DB entering indoor air with the other conditions from Example 1 being the same.

From Performance Data—Condensing Unit RAWL-090 with Air Handler RHGL-090

$$\begin{aligned}\text{Sens. Cap (Net)} &= 92,097 \text{ BTUH [27.00 kW]} \\ &\text{(from Example 1)}\end{aligned}$$

Adjust Capacity for temperature other than 80°F [27°C] entering air:

$$\text{Adjustment: } [1.10 \times 3360 \times (1-.16) \times (75-80)] = -15,523 \text{ BTUH [4.54 kW]}$$

Therefore, Sensible Capacity (Net) at 75°F [24°C] entering air is:

$$72,597 - 15,523 = 57,074 \text{ BTUH [16.72 kW] (Sens.)}$$

Example 3: Determine Net System Capacity Performance with 150 feet [45.7 m] equivalent length of 1<sup>3</sup>/<sub>8</sub>" [34.9 mm] O.D. vapor line, with other conditions in example 1 being the same.

From piping chart, Vapor Line System Capacity Loss, in this booklet:

$$\text{Capacity Loss} = 1.3\% \text{ per } 100 [30.5\text{m}] \text{ feet of line}$$

The condensing unit Performance Data includes 25 feet [7.6 m] of recommended vapor line; therefore, calculate the System performance with 125 feet [38.1 m] of additional line:

$$\begin{aligned}\text{Total Cap. (gross)} &= 95,700 - [(.013 \times 125 \div 100) \times 95,700] = 94,145 \text{ BTUH [27.59 kW]} \\ \text{Sens. Cap (gross)} &= 76,200 - [(.013 \times 125 \div 100) \times 76,200] = 74,962 \text{ BTUH [21.96 kW]}\end{aligned}$$

Thus, the Net Performance is:

$$\begin{aligned}\text{Total Cap. (Net)} &= 94,145 - 3,603 = 90,542 \text{ BTUH [26.53 kW]} \\ \text{Sens. Cap. (Net)} &= 74,962 - 3,603 = 71,329 \text{ BTUH [20.90 kW]}\end{aligned}$$

[ ] Designates Metric Conversions

# CONDENSING UNIT—GROSS CAPACITY AND POWER

RAWL-078						
°F [°C] OUTDOOR AMBIENT TEMPERATURE	SATURATED EVAPORATOR TEMPERATURE					
	40 [4]		45 [7]		50 [10]	
	MBH [kW]	KW	MBH [kW]	KW	MBH [kW]	KW
75 [24]	75.8 [22.20]	4.9	82.2 [24.09]	5.0	89.1 [26.12]	5.0
80 [27]	73.4 [21.52]	5.2	80.0 [23.43]	5.2	86.8 [25.43]	5.3
85 [29]	71.1 [20.83]	5.4	77.5 [22.72]	5.5	84.5 [24.75]	5.5
90 [32]	68.8 [20.15]	5.7	75.2 [22.03]	5.8	82.0 [24.03]	5.8
95 [35]	66.3 [19.43]	6.0	72.9 [21.35]	6.1	79.7 [23.35]	6.1
100 [38]	64.0 [18.75]	6.3	70.5 [20.66]	6.4	77.3 [22.66]	6.4
105 [41]	61.6 [18.06]	6.6	68.1 [19.95]	6.7	75.0 [21.98]	6.7
110 [43]	59.3 [17.38]	7.0	65.7 [19.26]	7.0	72.6 [21.26]	7.1
115 [46]	56.9 [16.66]	7.3	63.4 [18.58]	7.4	70.2 [20.58]	7.5

RAWL-090						
°F [°C] OUTDOOR AMBIENT TEMPERATURE	SATURATED EVAPORATOR TEMPERATURE					
	40 [4]		45 [7]		50 [10]	
	MBH [kW]	KW	MBH [kW]	KW	MBH [kW]	KW
75 [24]	96.5 [28.29]	6.0	104.5 [30.61]	6.2	112.7 [33.03]	6.3
80 [27]	93.7 [27.44]	6.3	101.6 [29.77]	6.5	109.9 [32.31]	6.6
85 [29]	90.8 [26.60]	6.6	98.7 [28.92]	6.8	107.1 [31.37]	6.9
90 [32]	88.0 [25.78]	7.0	95.8 [28.07]	7.1	104.2 [30.52]	7.2
95 [35]	85.1 [24.93]	7.3	92.9 [27.23]	7.4	101.3 [29.68]	7.6
100 [38]	82.2 [24.09]	7.7	90.2 [26.41]	7.8	98.5 [28.86]	8.0
105 [41]	79.3 [23.24]	8.1	87.3 [25.57]	8.3	95.6 [28.01]	8.4
110 [43]	76.5 [22.43]	8.6	84.4 [24.72]	8.7	92.7 [27.17]	8.9
115 [46]	73.7 [21.58]	9.1	81.5 [23.88]	9.3	89.8 [26.32]	9.4

KW —Condensing Unit Power (Compressor + Fan)

MBH—Gross Capacity X 1000 BTUH

NOTES: 1. All values at approximately 20°F [11.1°C] subcooling

2. Data includes 25 feet [7.62 m] of recommended vapor and liquid lines

[ ] Designates Metric Conversions

# UNIT DIMENSIONS & WEIGHTS

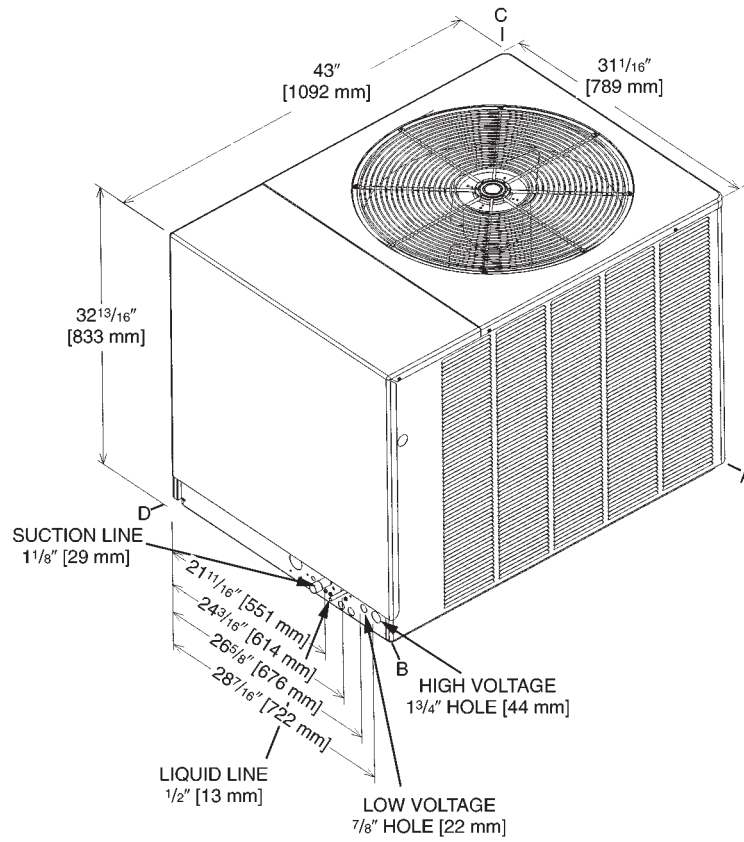

## 6.5 TON [22.86 kW] 7.5 TON [26.38 kW]

CORNER WEIGHTS (LBS.) [kg]

MODEL	TOTAL WEIGHT LBS. [kg]	Corner Weights, Lbs. [kg]			
		A	B	C	D
RAWL-078	291 [132]	50 [22.7]	73 [33.1]	69 [31.3]	99 [44.9]
RAWL-090	318 [144]	53 [24.0]	84 [38.1]	71 [32.2]	110 [49.9]

[ ] Designates Metric Conversions

## PERFORMANCE DATA @ ARI STANDARD CONDITIONS—COOLING: RAWL-

MODEL NUMBERS		80°F [26.5°C] DB/67°F [19.5°C] WB INDOOR AIR 95°F [35°C] DB OUTDOOR AIR				SOUND RATING	INDOOR CFM [L/s]
OUTDOOR UNIT RAWL-	INDOOR COIL AND/OR AIR HANDLER	TOTAL CAPACITY BTU/H [kW]	NET SENSIBLE BTU/H [kW]	NET LATENT BTU/H [kW]	EER		
Rev. 1/18/2008							
078CAZ	RHGL-090Z	77,000 [22.6]	59,000 [17.3]	18,000 [5.3]	11.20	8.6	2,600 [1227]
078DAZ	RHGL-090Z	77,000 [22.6]	59,000 [17.3]	18,000 [5.3]	11.20	8.6	2,600 [1227]
078YAZ	RHGL-090Z	77,000 [22.6]	59,000 [17.3]	18,000 [5.3]	11.20	8.6	2,600 [1227]
090CAZ	RHGL-090Z	90,000 [26.4]	64,000 [18.8]	26,000 [7.6]	11.20	8.6	2,800 [1321]
	RHGL-120Z	92,000 [27.0]	65,500 [19.2]	26,500 [7.8]	11.40	8.6	2,800 [1321]
090DAZ	RHGL-090Z	90,000 [26.4]	64,000 [18.8]	26,000 [7.6]	11.20	8.6	2,800 [1321]
	RHGL-120Z	92,000 [27.0]	65,500 [19.2]	26,500 [7.8]	11.40	8.6	2,800 [1321]
090YAZ	RHGL-090Z	90,000 [26.4]	64,000 [18.8]	26,000 [7.6]	11.20	8.6	2,800 [1321]
	RHGL-120Z	92,000 [27.0]	65,500 [19.2]	26,500 [7.8]	11.40	8.6	2,800 [1321]

① Highest sales volume tested combination required by D.O.E. test procedures.

[ ] Designates Metric Conversions

# ELECTRICAL & PHYSICAL DATA: RAWL-

Model No. RAWL-	ELECTRICAL						PHYSICAL										
	Phase Frequency (Hz) Voltage (Volts)		Compressor		Full Load Amperes (FLA)		Minimum Circuit Ampacity Amperes		Fuse or HACR Circuit Breaker		Outdoor Coil			Refrig. Per Circuit Oz. [g]		Weight	
			Rated Load Amperes (RLA)	Locked Rotor Amperes (LRA)	Fan Motor	Minimum Amperes	Maximum Amperes	Face Area Sq. Ft. [Sq. m]	No. Rows	CFM [L/s]	Net Lbs. [kg]	Ship Lbs. [kg]					
	Rev. 1/18/2008																
078CAZ	3-60-208/230	22.4/22.4	149	2.2	31/31	40/40	50/50	23 [2.14]	1.5	4700 [2218]	291 [132.0]	314 [142.2]	178 [5046]	291 [132.0]	314 [142.2]		
078DAZ	3-60-460	10.6	75	1.3	15	20	25	23 [2.14]	1.5	4700 [2218]	291 [132.0]	314 [142.2]	178 [5046]	291 [132.0]	314 [142.2]		
078YAZ	3-60-575	7.7	54	1	11	15	15	23 [2.14]	1.5	4700 [2218]	291 [132.0]	314 [142.2]	178 [5046]	291 [132.0]	314 [142.2]		
090CAZ	3-60-208/230	25/25	164	2.2	34/34	40/40	50/50	23 [2.14]	2.0	4700 [2218]	318 [144.2]	341 [154.7]	242 [6861]	318 [144.2]	341 [154.7]		
090DAZ	3-60-460	12.2	100	1.3	17	20	25	23 [2.14]	2.0	4700 [2218]	318 [144.2]	341 [154.7]	242 [6861]	318 [144.2]	341 [154.7]		
090YAZ	3-60-575	9	78	1	13	15	20	23 [2.14]	2.0	4700 [2218]	318 [144.2]	341 [154.7]	242 [6861]	318 [144.2]	341 [154.7]		

[ ] Designates Metric Conversions



# COOLING PERFORMANCE DATA

CONDENSING UNIT **RAWL-078**

WITH COOLING COIL **RHGL-090Z**

ENTERING INDOOR AIR @ 80°F [26.7°C] dbE ①											
wbE		71°F [21.7°C]			67°F [19.4°C]			63°F [17.2°C]			
CFM [L/s]		3120 [1472]	2600 [1227]	2080 [982]	3120 [1472]	2600 [1227]	2080 [982]	3120 [1472]	2600 [1227]	2080 [982]	
DR ②		.05	.08	.11	.05	.08	.11	.05	.08	.11	
OUTDOOR DRY BULB TEMPERATURE °F [°C]	75 [23.9]	Total BTUH [kW] Sens BTUH [kW] Power	95.0 [27.84] 64.0 [18.76] 5.4	91.7 [26.87] 55.2 [16.18] 5.3	88.3 [25.88] 47.0 [13.77] 5.2	91.1 [26.70] 74.6 [21.86] 5.3	87.9 [25.76] 65.0 [19.05] 5.2	84.7 [24.82] 56.0 [16.41] 5.1	85.8 [25.15] 81.2 [23.80] 5.2	82.8 [24.27] 71.3 [20.90] 5.1	79.7 [23.36] 61.8 [18.11] 5.0
	80 [26.7]	Total BTUH [kW] Sens BTUH [kW] Power	92.9 [27.23] 63.0 [18.46] 5.6	89.6 [26.26] 54.3 [15.91] 5.5	86.3 [25.29] 46.2 [13.54] 5.4	89.0 [26.08] 73.6 [21.57] 5.5	85.8 [25.15] 64.1 [18.79] 5.4	82.7 [24.24] 55.3 [16.21] 5.4	83.6 [24.50] 80.1 [23.48] 5.5	80.7 [23.65] 70.4 [20.63] 5.4	77.8 [22.80] 61.2 [17.94] 5.3
	85 [29.4]	Total BTUH [kW] Sens BTUH [kW] Power	90.6 [26.55] 61.8 [18.11] 5.9	87.4 [25.61] 53.3 [15.62] 5.8	84.3 [24.71] 45.5 [13.33] 5.7	86.7 [25.41] 72.5 [21.25] 5.8	83.7 [24.53] 63.3 [18.55] 5.7	80.7 [23.65] 54.7 [16.03] 5.6	81.4 [23.86] 79.2 [23.21] 5.7	78.5 [23.01] 69.5 [20.37] 5.6	75.7 [22.19] 60.5 [17.73] 5.5
	90 [32.2]	Total BTUH [kW] Sens BTUH [kW] Power	88.3 [25.88] 60.6 [17.76] 6.2	85.2 [24.97] 52.3 [15.33] 6.1	82.1 [24.06] 44.6 [13.07] 6.0	84.4 [24.74] 71.3 [20.90] 6.1	81.4 [23.86] 62.2 [18.23] 6.0	78.5 [23.01] 53.8 [15.77] 5.9	79.1 [23.18] 78.0 [22.86] 6.0	76.3 [22.36] 68.5 [20.08] 5.9	73.5 [21.54] 59.6 [17.47] 5.8
	95 [35]	Total BTUH [kW] Sens BTUH [kW] Power	85.8 [25.15] 59.3 [17.38] 6.5	82.8 [24.27] 51.2 [15.01] 6.4	79.8 [23.39] 43.7 [12.81] 6.2	82.0 [24.03] 70.0 [20.51] 6.4	79.1 [23.18] 61.1 [17.91] 6.3	76.2 [22.33] 52.8 [15.47] 6.2	76.6 [22.45] 76.5 [22.42] 6.3	73.9 [21.66] 67.3 [19.72] 6.2	71.2 [20.87] 58.6 [17.17] 6.1
	100 [37.8]	Total BTUH [kW] Sens BTUH [kW] Power	83.3 [24.41] 57.8 [16.94] 6.8	80.4 [23.56] 50.0 [14.65] 6.7	77.5 [22.71] 42.7 [12.51] 6.5	79.4 [23.27] 68.4 [20.05] 6.7	76.6 [22.45] 59.8 [17.53] 6.6	73.8 [21.63] 51.7 [15.15] 6.5	74.1 [21.72] 74.1 [21.72] 6.6	71.5 [20.95] 66.1 [19.37] 6.5	68.9 [20.19] 57.6 [16.88] 6.4
	105 [40.6]	Total BTUH [kW] Sens BTUH [kW] Power	80.7 [23.65] 56.2 [16.47] 7.1	77.8 [22.80] 48.5 [14.21] 7.0	75.0 [21.98] 41.4 [12.13] 6.9	76.8 [22.51] 66.9 [19.61] 7.0	74.1 [21.72] 58.5 [17.14] 6.9	71.4 [20.93] 50.6 [14.83] 6.8	71.4 [20.93] 71.4 [20.93] 6.9	68.9 [20.19] 64.7 [18.96] 6.8	66.4 [19.46] 56.4 [16.53] 6.7
	110 [43.3]	Total BTUH [kW] Sens BTUH [kW] Power	77.9 [22.83] 54.4 [15.94] 7.4	75.2 [22.04] 47.1 [13.80] 7.3	72.4 [21.22] 40.2 [11.78] 7.2	74.0 [21.69] 65.2 [19.11] 7.3	71.4 [20.93] 57.0 [16.71] 7.2	68.8 [20.16] 49.3 [14.45] 7.1	68.7 [20.13] 68.7 [20.13] 7.3	66.3 [19.43] 63.3 [18.55] 7.1	63.9 [18.73] 55.2 [16.18] 7.0
	115 [46.1]	Total BTUH [kW] Sens BTUH [kW] Power	75.0 [21.98] 52.6 [15.42] 7.8	72.4 [21.22] 45.5 [13.33] 7.7	69.8 [20.46] 38.9 [11.40] 7.5	71.2 [20.87] 63.3 [18.55] 7.7	68.7 [20.13] 55.4 [16.24] 7.6	66.2 [19.40] 48.0 [14.07] 7.4	65.8 [19.28] 65.8 [19.28] 7.6	63.5 [18.61] 61.6 [18.05] 7.5	61.2 [17.94] 53.8 [15.77] 7.4

CONDENSING UNIT **RAWL-090**

WITH COOLING COIL **RHGL-090Z**

ENTERING INDOOR AIR @ 80°F [26.7°C] dbE ①											
wbE		71°F [21.7°C]			67°F [19.4°C]			63°F [17.2°C]			
CFM [L/s]		3360 [1586]	2800 [1321]	2240 [1057]	3360 [1586]	2800 [1321]	2240 [1057]	3360 [1586]	2800 [1321]	2240 [1057]	
DR ②		.09	.13	.19	.09	.13	.19	.09	.13	.19	
OUTDOOR DRY BULB TEMPERATURE °F [°C]	75 [23.9]	Total BTUH [kW] Sens BTUH [kW] Power	106.7 [31.27] 66.7 [19.55] 6.2	103.0 [30.19] 57.3 [16.79] 6.1	99.2 [29.07] 48.5 [14.21] 6.0	102.6 [30.07] 79.2 [23.21] 6.1	99.0 [29.01] 68.8 [20.16] 6.0	95.4 [27.96] 59.1 [17.32] 5.9	96.9 [28.40] 89.8 [26.32] 5.9	93.5 [27.40] 78.7 [23.06] 5.8	90.1 [26.41] 68.3 [20.02] 5.7
	80 [26.7]	Total BTUH [kW] Sens BTUH [kW] Power	105.6 [30.95] 66.4 [19.46] 6.5	101.8 [29.83] 56.9 [16.68] 6.4	98.1 [28.75] 48.2 [14.13] 6.3	101.4 [29.72] 78.7 [23.06] 6.4	97.8 [28.66] 68.4 [20.05] 6.3	94.3 [27.64] 58.8 [17.23] 6.2	95.8 [28.08] 89.5 [26.23] 6.3	92.4 [27.08] 78.5 [23.01] 6.2	89.0 [26.08] 68.1 [19.96] 6.0
	85 [29.4]	Total BTUH [kW] Sens BTUH [kW] Power	104.0 [30.48] 65.6 [19.23] 6.9	100.4 [29.42] 56.4 [16.53] 6.8	96.7 [28.34] 47.8 [14.01] 6.6	99.9 [29.28] 78.2 [22.92] 6.7	96.4 [28.25] 68.0 [19.93] 6.6	92.9 [27.23] 58.5 [17.14] 6.5	94.2 [27.61] 88.8 [26.02] 6.6	90.9 [26.64] 77.9 [22.83] 6.5	87.6 [25.67] 67.6 [19.81] 6.4
	90 [32.2]	Total BTUH [kW] Sens BTUH [kW] Power	102.1 [29.92] 64.8 [18.99] 7.2	98.6 [28.90] 55.8 [16.35] 7.1	95.0 [27.84] 47.3 [13.86] 7.0	98.0 [28.72] 77.3 [22.65] 7.1	94.5 [27.70] 67.2 [19.69] 7.0	91.1 [26.70] 57.8 [16.94] 6.9	92.3 [27.05] 87.9 [25.76] 7.0	89.1 [26.11] 77.2 [22.63] 6.8	85.9 [25.17] 67.1 [19.67] 6.7
	95 [35]	Total BTUH [kW] Sens BTUH [kW] Power	99.9 [29.28] 63.9 [18.73] 7.6	96.4 [28.25] 54.9 [16.09] 7.5	92.9 [27.23] 46.6 [13.66] 7.3	95.7 [28.05] 76.2 [22.33] 7.5	92.4 [27.08] 66.4 [19.46] 7.3	89.0 [26.08] 57.1 [16.73] 7.2	90.1 [26.41] 86.9 [25.47] 7.3	86.9 [25.47] 76.3 [22.36] 7.2	83.8 [24.56] 66.4 [19.46] 7.1
	100 [37.8]	Total BTUH [kW] Sens BTUH [kW] Power	97.3 [28.52] 62.5 [18.32] 8.0	93.8 [27.49] 53.7 [15.74] 7.9	90.4 [26.49] 45.6 [13.36] 7.7	93.1 [27.28] 75.0 [21.98] 7.9	89.8 [26.32] 65.3 [19.14] 7.7	86.6 [25.38] 56.3 [16.50] 7.6	87.4 [25.61] 85.6 [25.09] 7.7	84.4 [24.74] 75.3 [22.07] 7.6	81.3 [23.83] 65.5 [19.20] 7.5
	105 [40.6]	Total BTUH [kW] Sens BTUH [kW] Power	94.3 [27.64] 61.0 [17.88] 8.4	91.0 [26.67] 52.5 [15.39] 8.3	87.6 [25.67] 44.5 [13.04] 8.1	90.1 [26.41] 73.5 [21.54] 8.3	86.9 [25.47] 64.0 [18.76] 8.1	83.8 [24.56] 55.2 [16.18] 8.0	84.5 [24.76] 84.2 [24.68] 8.2	81.5 [23.89] 74.0 [21.69] 8.0	78.5 [23.01] 64.4 [18.87] 7.9
	110 [43.3]	Total BTUH [kW] Sens BTUH [kW] Power	90.9 [26.64] 59.3 [17.38] 8.9	87.7 [25.70] 51.0 [14.95] 8.7	84.5 [24.76] 43.3 [12.69] 8.6	86.7 [25.41] 71.6 [20.98] 8.7	83.7 [24.53] 62.5 [18.32] 8.6	80.7 [23.65] 53.9 [15.80] 8.4	81.1 [23.77] 81.1 [23.77] 8.6	78.3 [22.95] 72.6 [21.28] 8.4	75.4 [22.10] 63.2 [18.52] 8.3
	115 [46.1]	Total BTUH [kW] Sens BTUH [kW] Power	87.2 [25.56] 57.4 [16.82] 9.3	84.1 [24.65] 49.4 [14.48] 9.2	81.1 [23.77] 42.1 [12.34] 9.0	83.0 [24.32] 69.8 [20.46] 9.2	80.1 [23.48] 60.9 [17.85] 9.0	77.2 [22.63] 52.6 [15.42] 8.9	77.4 [22.68] 77.4 [22.68] 9.1	74.7 [21.89] 70.9 [20.78] 8.9	71.9 [21.07] 61.7 [18.08] 8.7

DR —Depression ratio  
dbE —Entering air dry bulb  
wbE —Entering air wet bulb

Total —Total capacity x 1000 BTUH  
Sens —Sensible capacity x 1000 BTUH  
Power —KW input

**NOTES:**

- ① When the entering air dry bulb is other than 80°F [27°C], adjust the sensible capacity from the table by adding [1.10 x CFM x (1 - DR) x (dbE - 80)].
- ② Total and sensible capacity is gross, with no deduction for indoor blower motor heat.
- ③ Power input is gross, which does not include indoor blower motor.
- ④ Refer to the "Systems Selection Performance Program and Data Diskette" to interpolate or extrapolate above data.

[ ] Designates Metric Conversions

# COOLING PERFORMANCE DATA

CONDENSING UNIT **RAWL-090**

WITH COOLING COIL **RHGL-120Z**

ENTERING INDOOR AIR @ 80°F [26.7°C] dbE ①											
wbE		71°F [21.7°C]			67°F [19.4°C]			63°F [17.2°C]			
CFM [L/s]		3360 [1586]	2800 [1321]	2240 [1057]	3360 [1586]	2800 [1321]	2240 [1057]	3360 [1586]	2800 [1321]	2240 [1057]	
DR ①		.06	.11	.18	.06	.11	.18	.06	.11	.18	
OUTDOOR DRY BULB TEMPERATURE °F [°C]	75 [23.9]	Total BTUH [kW] Sens BTUH [kW] Power	108.8 [31.9] 68.4 [20.1] 6.2	105.0 [30.8] 58.8 [17.2] 6.1	101.2 [29.7] 49.9 [14.6] 6.0	104.6 [30.7] 80.8 [23.7] 6.1	101.0 [29.6] 70.3 [20.6] 6.0	97.3 [28.5] 60.4 [17.7] 5.9	99.0 [29.0] 91.5 [26.8] 5.9	95.5 [28.0] 80.2 [23.5] 5.8	92.0 [27.0] 69.5 [20.4] 5.7
	80 [26.7]	Total BTUH [kW] Sens BTUH [kW] Power	107.6 [31.5] 68.0 [19.9] 6.5	103.8 [30.4] 58.4 [17.1] 6.4	100.1 [29.3] 49.6 [14.5] 6.3	103.5 [30.3] 80.5 [23.6] 6.4	99.8 [29.2] 69.9 [20.5] 6.3	96.2 [28.2] 60.1 [17.6] 6.2	97.8 [28.7] 91.2 [26.7] 6.3	94.4 [27.7] 80.0 [23.5] 6.2	91.0 [26.7] 69.5 [20.4] 6.0
	85 [29.4]	Total BTUH [kW] Sens BTUH [kW] Power	106.1 [31.1] 67.5 [19.8] 6.9	102.4 [30.0] 58.0 [17.0] 6.8	98.7 [28.9] 49.2 [14.4] 6.6	101.9 [29.9] 79.8 [23.4] 6.7	98.4 [28.8] 69.5 [20.4] 6.6	94.8 [27.8] 59.7 [17.5] 6.5	96.3 [28.2] 90.5 [26.5] 6.6	92.9 [27.2] 79.4 [23.3] 6.5	89.5 [26.2] 68.9 [20.2] 6.4
	90 [32.2]	Total BTUH [kW] Sens BTUH [kW] Power	104.2 [30.5] 66.6 [19.5] 7.2	100.6 [29.5] 57.3 [16.8] 7.1	96.9 [28.4] 48.6 [14.3] 7.0	100.0 [29.3] 78.9 [23.1] 7.1	96.5 [28.3] 68.7 [20.1] 7.0	93.0 [27.3] 59.1 [17.3] 6.9	94.4 [27.7] 89.7 [26.3] 7.0	91.1 [26.7] 78.7 [23.1] 6.8	87.8 [25.7] 68.4 [20.1] 6.7
	95 [35]	Total BTUH [kW] Sens BTUH [kW] Power	101.9 [29.9] 65.5 [19.2] 7.6	98.4 [28.8] 56.4 [16.5] 7.5	94.8 [27.8] 47.9 [14.0] 7.3	97.8 [28.7] 78.0 [22.9] 7.5	94.4 [27.7] 67.9 [19.9] 7.3	90.9 [26.6] 58.4 [17.1] 7.2	92.1 [27.0] 88.6 [26.0] 7.3	88.9 [26.1] 77.8 [22.8] 7.2	85.7 [25.1] 67.6 [19.8] 7.1
	100 [37.8]	Total BTUH [kW] Sens BTUH [kW] Power	99.3 [29.1] 64.2 [18.8] 8.0	95.8 [28.1] 55.2 [16.2] 7.9	92.4 [27.1] 47.0 [13.8] 7.7	95.2 [27.9] 76.8 [22.5] 7.9	91.8 [26.9] 66.8 [19.6] 7.7	88.5 [25.9] 57.6 [16.9] 7.6	89.5 [26.2] 87.4 [25.6] 7.7	86.4 [25.3] 76.8 [22.5] 7.6	83.2 [24.4] 66.7 [19.6] 7.5
	105 [40.6]	Total BTUH [kW] Sens BTUH [kW] Power	96.3 [28.2] 62.6 [18.4] 8.4	93.0 [27.3] 54.0 [15.8] 8.3	89.6 [26.3] 45.9 [13.5] 8.1	92.2 [27.0] 75.2 [22.0] 8.3	88.9 [26.1] 65.5 [19.2] 8.1	85.7 [25.1] 56.5 [16.6] 8.0	86.5 [25.4] 85.8 [25.2] 8.2	83.5 [24.5] 75.5 [22.1] 8.0	80.5 [23.6] 65.7 [19.3] 7.9
	110 [43.3]	Total BTUH [kW] Sens BTUH [kW] Power	93.0 [27.3] 61.0 [17.9] 8.9	89.7 [26.3] 52.5 [15.4] 8.7	86.5 [25.4] 44.7 [13.1] 8.6	88.8 [26.0] 73.4 [21.5] 8.7	85.7 [25.1] 64.0 [18.8] 8.6	82.6 [24.2] 55.2 [16.2] 8.4	83.2 [24.4] 83.2 [24.4] 8.6	80.3 [23.5] 74.1 [21.7] 8.4	77.3 [22.7] 64.5 [18.9] 8.3
	115 [46.1]	Total BTUH [kW] Sens BTUH [kW] Power	89.3 [26.2] 59.1 [17.3] 9.3	86.1 [25.2] 50.9 [14.9] 9.2	83.0 [24.3] 43.3 [12.7] 9.0	85.1 [24.9] 71.5 [21.0] 9.2	82.1 [24.1] 62.4 [18.3] 9.0	79.1 [23.2] 53.9 [15.8] 8.9	79.5 [23.3] 79.5 [23.3] 9.1	76.7 [22.5] 72.4 [21.2] 8.9	73.9 [21.7] 63.1 [18.5] 8.7

DR —Depression ratio  
dbE—Entering air dry bulb  
wbE—Entering air wet bulb

Total —Total capacity x 1000 BTUH  
Sens —Sensible capacity x 1000 BTUH  
Power—KW input

**NOTES:**

- ① When the entering air dry bulb is other than 80°F [27°C], adjust the sensible capacity from the table by adding [1.10 x CFM x (1 – DR) x (dbE – 80)].
- ② Total and sensible capacity is gross, with no deduction for indoor blower motor heat.
- ③ Power input is gross, which does not include indoor blower motor.
- ④ Refer to the “Systems Selection Performance Program and Data Diskette” to interpolate or extrapolate above data.

[ ] Designates Metric Conversions

# TYPICAL REFRIGERANT PIPING RECOMMENDATIONS

## General Notes:

1. Vertical risers not to exceed 60 feet [18.29 m].
2. Locate the condensing unit and evaporator(s) as close together as possible to minimize piping runs.
3. Condensing units are shipped with a nitrogen holding charge. Evacuate condensing unit before charging with refrigerant.

EQUIVALENT LENGTH (FT.) [m] OF STRAIGHT TYPE "L" TUBING FOR NON-FERROUS VALVES AND FITTINGS (BRAZED)						
TUBE SIZE (IN.) [mm] O.D.	SOLENOID VALVE	ANGLE VALVE	SHORT RADIUS ELL	LONG RADIUS ELL	TEE LINE FLOW	TEE BRANCH FLOW
1/2 [12.7]	70 [21.3]	8.3 [2.5]	1.6 [0.5]	1.0 [0.3]	1.0 [0.3]	3.1 [0.9]
5/8 [15.88]	72 [21.9]	10.4 [3.2]	1.9 [0.6]	1.2 [0.4]	1.2 [0.4]	3.6 [1.1]
3/4 [19.05]	75 [22.9]	12.5 [3.8]	2.1 [0.7]	1.4 [0.4]	1.4 [0.4]	4.2 [1.3]
7/8 [22.23]	78 [23.8]	14.6 [4.4]	2.4 [0.7]	1.6 [0.5]	1.6 [0.5]	4.8 [1.5]
1 1/8 [28.58]		18.8 [5.7]	3.0 [0.9]	2.0 [0.6]	2.0 [0.6]	6.0 [1.8]
1 3/8 [34.93]		22.9 [7.0]	3.6 [1.1]	2.4 [0.7]	2.4 [0.7]	7.2 [2.2]
1 5/8 [41.28]		27.1 [8.3]	4.2 [1.3]	2.8 [0.8]	2.8 [0.8]	8.4 [2.6]
2 1/8 [53.98]		35.4 [10.8]	5.3 [1.6]	3.5 [1.1]	3.5 [1.1]	10.7 [3.3]

LINEAR LENGTH (FT.) [m]	RECOMMENDED VAPOR AND LIQUID LINE SIZES FOR VARIOUS LENGTHS OF RUN			
	LIQUID LINE O.D. SIZES (IN.) [mm]		VAPOR LINE O.D. SIZES (IN.) [mm]	
	078	090*	078	090
0-15 [0-4.57]	1/2 [12.7]	1/2 [12.7]	1 1/8 [28.58]	1 1/8 [28.58]
16-50 [4.88-15.24]	1/2 [12.7]	1/2 [12.7]	1 1/8 [28.58]	1 1/8 [28.58]
51-100 [15.54-30.48]	1/2 [12.7]	1/2 [12.7]	1 1/8 [28.58]	1 3/8 [34.93]
101-150 [30.78-45.72]	1/2 [12.7]	1/2 [12.7]	1 3/8 [34.93]	1 3/8 [34.93]

**NOTE:** Runs between condenser and evaporator not to exceed 150' [45.7 m] linear length.

\*See note ④ under liquid line pressure drop chart. Use 5/8" [15.88 mm] liquid line with solenoid valve.

## LIQUID LINE PRESSURE DROP PER 100 FEET [30.48 m] EQUIVALENT LENGTH (TYPE L COPPER TUBING)

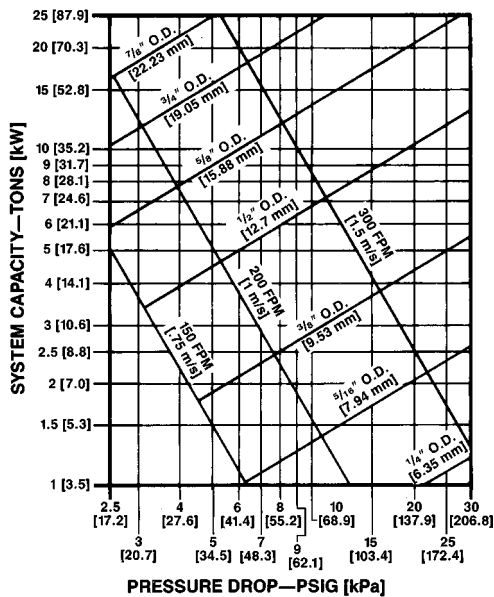

### NOTES:

- 1) When evaporator coil is above condenser, the pressure drop due to vertical lift (.5 PSIG per foot of lift) [1.05 kPa per meter] **must** be added to the pressure drop derived from this curve.
- 2) Size liquid line for **no more** than 10°F [5.6°C] loss (approximately 50 PSIG [344.7 kPa] total pressure drop).
- 3) **Do not oversize liquid line.** Oversized liquid lines add significantly to the amount of refrigerant required to charge the system.
- 4) The maximum recommended velocity with solenoid valves or other quick closing devices in the liquid line is 300 FPM [1.5 m/s].

## VAPOR LINE SYSTEM CAPACITY LOSS IN PERCENT PER 100 FEET [30.48 m] EQUIVALENT LENGTH (TYPE L COPPER TUBING)

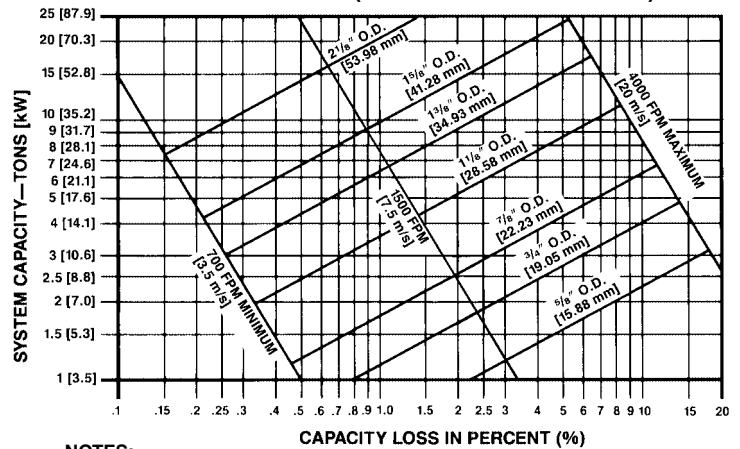

### NOTES:

- 1) The minimum velocity line (700 fpm) [3.6 m/s] is recommended.
- 2) For vapor pressure drop (PSIG) [6.9 kPa], multiply percent (%) loss by 1.18.
- 3) Size vapor lines for no more than 2°F [1.1°C] loss which corresponds to approximately 5 PSIG [34.4 kPa] pressure drop.
- 4) Pitch all horizontal vapor lines downward in the direction of flow (1/2" [12.7 mm] to 10' [3.0 m] run).

## WARNING

**Do not use oxygen to purge lines or pressure system for leak test. Oxygen reacts violently with oil, which can cause an explosion resulting in severe personal injury or death.**

## COIL ABOVE CONDENSING UNIT

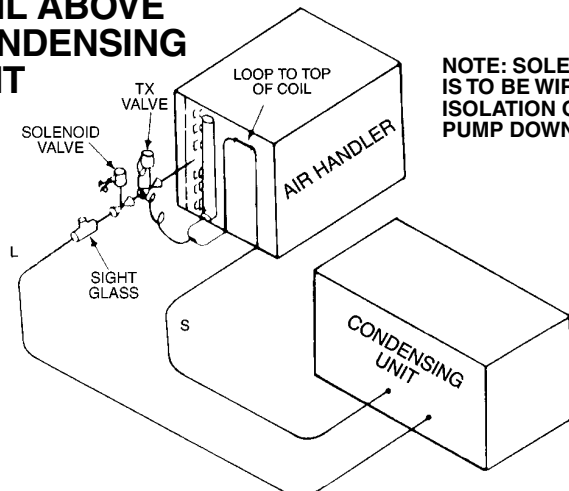

**NOTE: SOLENOID VALVE IS TO BE WIRED FOR ISOLATION ONLY, NOT PUMP DOWN.**

# TYPICAL REFRIGERANT PIPING RECOMMENDATIONS (cont.)

## REQUIRED OZS. R-410A CHARGE PER FT. [m] OF TUBING

TUBE SIZE O.D. (IN.) [mm]	LIQUID (OZ.) [g]	VAPOR (OZ.) [g]
1/2 [12.7]	1.06 [30.0]	.04 [1.13]
5/8 [15.88]	1.65 [46.7]	.07 [1.98]
3/4 [19.05]	2.46 [69.7]	.10 [2.83]
7/8 [22.23]	3.28 [92.9]	.13 [3.68]
1 1/8 [28.58]		.22 [6.23]
1 3/8 [34.93]		.34 [9.63]
1 5/8 [41.28]		.48 [13.60]
2 1/8 [53.98]		.84 [23.81]

Quantities based on 110°F liquid and 45°F vapor.

## GENERAL INSTALLATION

The condensing unit should be installed outdoors. It should be located as near as possible to the evaporator section to keep connecting refrigerant tubing lengths to a minimum. The unit must be installed to allow a free air flow to the condenser coils.

If several units are installed adjacent to each other, care must be taken to avoid recirculation of air from one condenser to another. In all installations, adequate space must be provided for installation and servicing.

### CLEARANCES

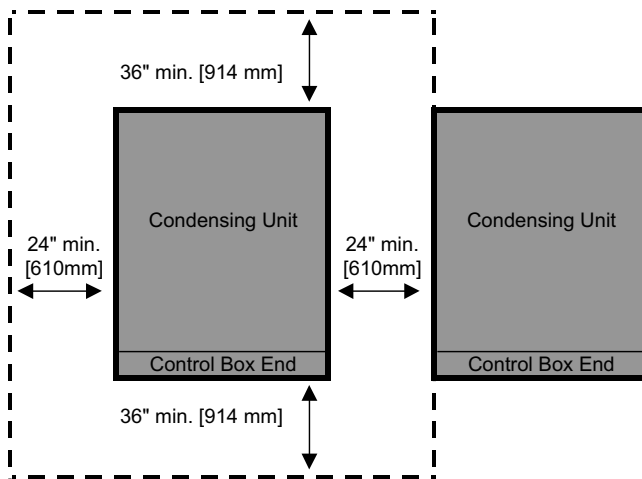

The unit must not be connected to any duct work. Do not locate unit under a roof drip; if necessary, install gutters, etc., to prevent water run-off from hitting the unit. To prevent air recirculation, it is recommended that the unit not be installed under an overhang, but if necessary **allow a minimum of 60 inches [1524 mm] above the unit for air discharge.**

## ROOFTOP INSTALLATION

If rooftop installation is required, make certain that the building construction is adequate for the weight of the unit. (Refer to physical data chart.) Before placing the unit on the roof, make certain that the nylon rigging slings are of sufficient length to maintain equilibrium of the unit when lifting. Under no circumstances should the unit be lifted by only one corner for rooftop installation.

## BASIC SYSTEM CHARGE\*

UNIT MODEL	BASIC SYSTEM CHARGE, OZ, [g]*
RAWL-078	178 [5046]
RAWL-090	239 [6775]

\*System with 0 feet [m] of tubing.

## RIGGING

### RAWL 078 & 090 MODELS

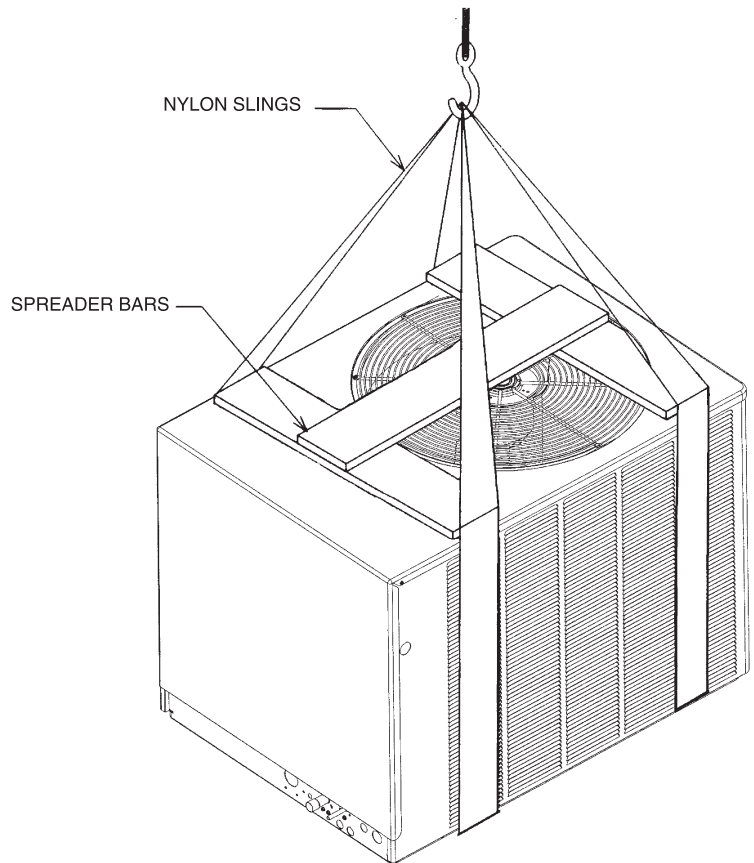

## SLAB INSTALLATION

Condensing units should be set on a solid level foundation. When installed at ground level, the unit should be placed on a 6 inch [152.4 mm] cement slab. If the pad is formed at the installation site, do not pour the pad tight against the structure, otherwise vibration will be transmitted from the unit through the pad.

[ ] Designates Metric Conversions

# TYPICAL WIRING SCHEMATIC

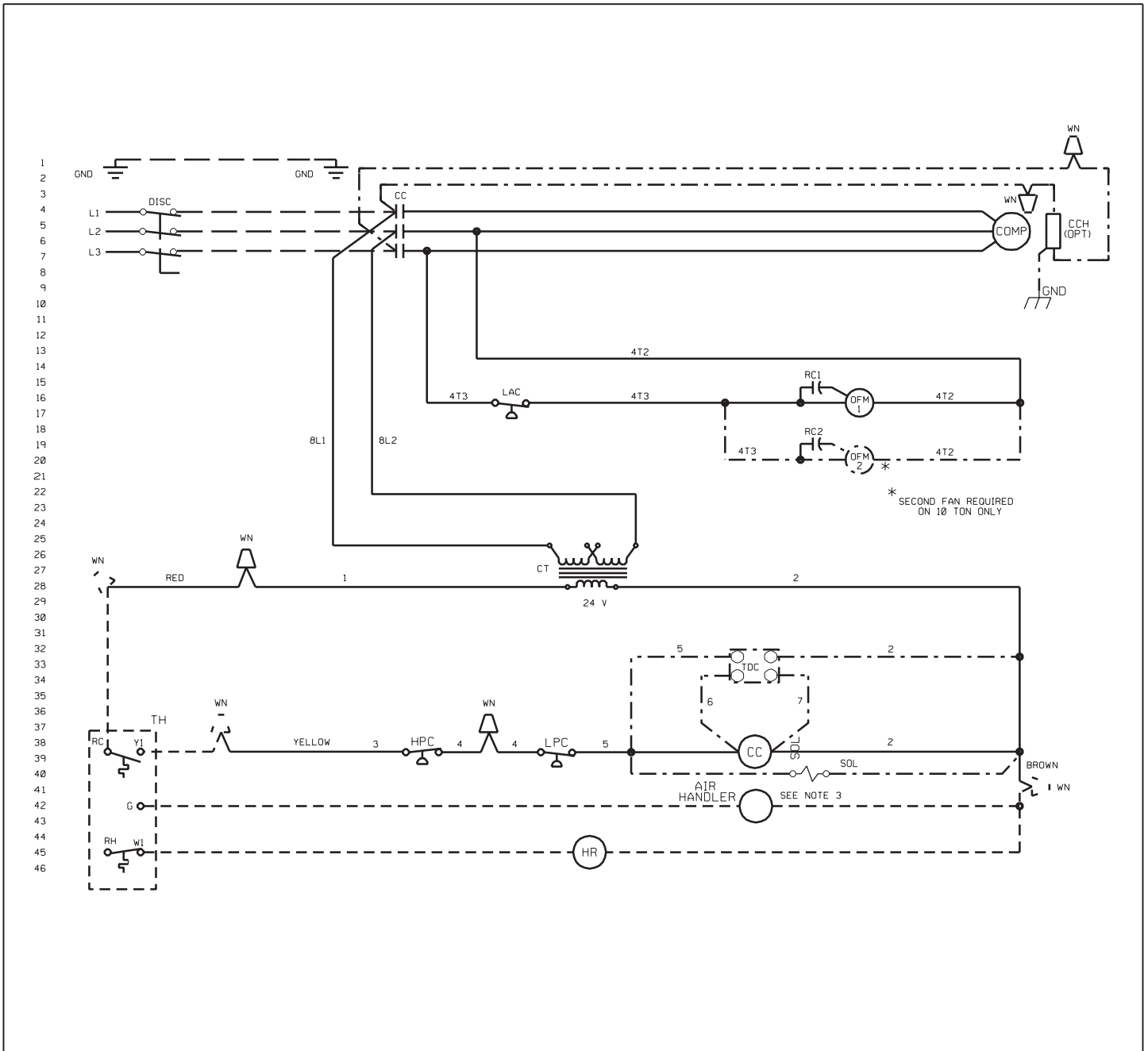

DWG. NO. 90-42456-02 REV. 14	<b>COMPONENT CODE</b> CC COMPRESSOR CONTACTOR CCH CRANKCASE HEATER COMP COMPRESSOR CT CONTROL TRANSFORMER HPC HIGH PRESSURE CONTROL HR HEATER RELAY LAC LOW AMBIENT CONTROL LPC LOW PRESSURE CONTROL OFM OUTDOOR FAN MOTOR RC RUN CAPACITOR TH THERMOSTAT (H/C) TDC TIME DELAY CONTROL WN WIRE NUT	<b>NOTES:</b> REPLACEMENT WIRE & FUSES MUST BE 1. SAME TYPE & SIZE AS ORIGINAL. 2. UNIT MUST BE PERMANENTLY GROUNDED & CONFORM TO N.E.C. & LOCAL CODES. 3. MAXIMUM IN RUSH VA NOT TO EXCEED 92 VA. 4. MINIMUM WIRE SIZE BASED ON 75 DEGREES C INSULATION COPPER WIRE.	<b>WIRING INFORMATION</b> <b>LINE VOLTAGE</b> -FACTORY STANDARD ————— -FACTORY OPTION - - - - - -FIELD INSTALLED - - - - - <b>LOW VOLTAGE</b> -FACTORY STANDARD ————— -FACTORY OPTION - - - - - -FIELD INSTALLED - - - - - <b>REPLACEMENT WIRE</b> -MUST BE THE SAME SIZE AND TYPE OF INSULATION AS ORIGINAL (105° C MIN.) <b>WARNING</b> -CABINET MUST BE PERMANENTLY GROUNDED AND CONFORM TO I.E.C., N.E.C., C.E.C., NATIONAL WIRING REGULATIONS, AND LOCAL CODES AS APPLICABLE.	<b>WIRE COLOR CODE</b> BK__BLACK O___ORANGE BR__BROWN PR__PURPLE BL__BLUE R___RED G___GREEN W___WHITE GY__GRAY Y___YELLOW
	<b>WIRING SCHEMATIC</b> CONDENSING UNIT 6½, 7½, 10 TON & 12½ TON 208/230, 380, 460 3PH 60Hz & 200/220, 380/415 3PH 50Hz & 6½ & 7½ TON - 575 3PH 60Hz			DR. BY MCB APP. BY DATE 8-29-90 DWG. NO. 90-42456-02 REV 14

## SEQUENCE OF OPERATION

1. When the room temperature is higher than the thermostat setting, the thermostat contacts close and energize the compressor contactor (CC) through the high pressure & low pressure control contacts. If the unit has "short cycled" and the optional time delay (TDC) has been supplied, the contactor coil (CC) will remain de-energized for up to five (5) minutes.
2. The system will continue cooling operation, as long as the contacts of all safety devices are closed and until the thermostat is satisfied.
3. When the thermostat is satisfied compressor or contactor (CC) is de-energized.

## GENERAL TERMS OF LIMITED WARRANTY\*

Rheem will furnish a replacement for any part of this product which fails in normal use and service within the applicable period stated below, in accordance with the terms of the limited warranty.

Air Conditioner Motor Compressor .....Five (5) Years  
Any Other Part .....One (1) Year  
\*For Complete Details of the Limited Warranty, Including Applicable Terms and Conditions, See Your Local Installer or Contact the Manufacturer for a Copy.

## GUIDE SPECIFICATIONS

Furnish and install as shown on the drawing Rheem Model \_\_\_\_\_ air cooled condensing unit suitable for outdoor application.

**COMPRESSOR**—Unit shall have (1) compressor. It is to be of the welded hermetic type with durable insulation on the motor windings. It shall be externally mounted on rubber grommets to reduce vibration transmission and noise to surrounding area. Maximum power input shall not be more than \_\_\_\_\_ on 6.5 nominal ton [22.86 kW] units and \_\_\_\_\_ on 7.5 nominal ton [26.38 kW] units \_\_\_\_\_ at conditions specified.

**LOW AMBIENT CONTROL**—All units shall have standard head pressure controls that cycle the condenser fan motors to maintain condensing pressures for operation down to 0°F [°C] ambient.

**CAPACITY**—Capacity shall be \_\_\_\_\_ BTU/HR when operating at \_\_\_\_\_ °F [°C] saturated suction temperature.

**MOTORS & FANS**—Each unit shall have one (6.5 & 7.5 ton) [22.86 & 26.38 kW] sleeve bearing, permanently lubricated motor(s) fixed with direct-drive, multi-bladed fan(s). Motor(s) shall be equipped with inherent overload protection. Motor(s) & fan(s) shall be mounted on hinged top panel for easy access. Condenser air shall discharge vertically.

**COILS**—Coils shall be fabricated of 3/8" [9.53 mm] O.D. seamless copper tubing and aluminum fins with die-formed collars mechanically bonded to tubes arranged in a staggered pattern. All coils shall be submitted to an air pressure test of up to 300 PSIG after fabrication and dehydrated. Units shall be shipped with a dry nitrogen holding charge. Coil design shall permit removal of service panels without affecting operation of the

unit. Airflow shall be drawn through design providing uniform air distribution across the coil surface.

**CASINGS**—Casings shall make unit suitable for outdoor installation. Casing, base pan and framework shall be manufactured of galvanized sheet metal subjected to multistage cleaning, pre-treated and finished with a durable powder coat paint, capable of withstanding a 1000-HR salt spray test per ASTM B 117. Units shall have stamped louver panels offering 100% protection of the condenser coil face. Openings shall be provided for power. Dimensions of entire assembly shall be not more than \_\_\_\_\_ inches [mm] high, \_\_\_\_\_ inches [mm] long and \_\_\_\_\_ inches [mm] wide.

**REFRIGERATION CIRCUIT**—Shall include the compressor, the condenser coils, all internal refrigerant piping, a liquid line service valve. Refrigerant stubs shall be extended through the cabinet for external field connection without affecting accessibility to compressor compartment.

**CONTROL PANEL**—The panel shall be designed for single power source to the compressor and fan motor(s) and shall include low ambient fan cycling control, and compressor across-the-line contactor.

**SAFETY CONTROLS**—Manual reset high pressure and automatic reset low pressure control shall be provided.

**FACTORY TESTING**—All units shall be test run at the factory. They shall experience the following control testing procedures: high pressure control, switching of electrical components, and compressor operation.

[ ] Designates Metric Conversions

# NOTES

**Before proceeding with installation, refer to installation instructions packaged with each model, as well as complying with all Federal, State, Provincial, and Local codes, regulations, and practices.**

**Rheem Heating,  
Cooling and  
Water Heating**

P.O. Box 17010, Fort Smith, AR 72917



*"In keeping with its policy of continuous progress and product improvement, Rheem reserves the right to make changes without notice."*