

Service Facts

Link Communicating / Variable Speed Outdoor Compatible Convertible Air Handlers

TAMXA0A24V21DA
TAMXA0B30V31DA
TAMXA0C36V31DA
TAMXA0C42V41DA
TAMXA0C48V41DA
TAMXA0C60V51DA

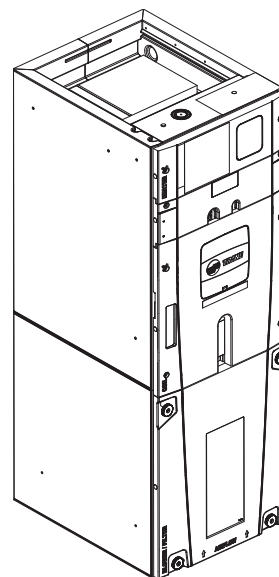

The Diagnostics Mobile App is available by scanning a QR code located inside this unit or by searching for the Link Diagnostics app in your App Store.

Note: "Graphics in this document are for representation only. Actual model may differ in appearance."

Note: For use with BAYEA series heaters ONLY.

⚠ SAFETY WARNING

Only qualified personnel should install and service the equipment. The installation, starting up, and servicing of heating, ventilating, and air-conditioning equipment can be hazardous and requires specific knowledge and training. Improperly installed, adjusted or altered equipment by an unqualified person could result in death or serious injury. When working on the equipment, observe all precautions in the literature and on the tags, stickers, and labels that are attached to the equipment.

SAFETY SECTION

AIR HANDLERS

Important — This document contains a wiring diagram, a parts list, and service information. This is customer property and is to remain with this unit. Please return to service information pack upon completion of work.

⚠ WARNING

HAZARDOUS VOLTAGE!

Failure to follow this Warning could result in property damage, severe personal injury, or death.

Disconnect all electric power, including remote disconnects before servicing. Follow proper lockout/tagout procedures to ensure the power cannot be inadvertently energized.

⚠ CAUTION

GROUNDING REQUIRED!

Failure to inspect or use proper service tools may result in equipment damage or personal injury. Reconnect all grounding devices. All parts of this product that are capable of conducting electrical current are grounded. If grounding wires, screws, straps, clips, nuts, or washers used to complete a path to ground are removed for service, they must be returned to their original position and properly fastened.

⚠ WARNING

LIVE ELECTRICAL COMPONENTS!

Failure to follow this Warning could result in property damage, severe personal injury, or death.

Follow all electrical safety precautions when exposed to live electrical components. It may be necessary to work with live electrical components during installation, testing, servicing, and troubleshooting of this product.

⚠ WARNING

PRESSURIZED REFRIGERANT!

Failure to follow this Warning could result in personal injury

System contains oil and refrigerant under high pressure. Recover refrigerant to relieve pressure before opening the system. Do not use non-approved refrigerants or refrigerant substitutes or refrigerant additives.

⚠ CAUTION

SHARP EDGE HAZARD!

Failure to follow this Caution could result in property damage or personal injury.

Be careful of sharp edges on equipment or any cuts made on sheet metal while installing or servicing.

⚠ WARNING

WARNING!

This product can expose you to chemicals including lead, which are known to the State of California to cause cancer and birth defects or other reproductive harm. For more information go to www.P65Warnings.ca.gov.

Important: Panel damage can occur with prolonged exposure to POE lubricants. Air handler front panels that come in contact with POE oil must be washed immediately with soapy water.

Important: The TAMX air handlers are only compatible with BAYEA** internal electric heaters.

Note: Representative illustrations only included in this document. Most illustrations display the upflow configuration.

Product Specifications

MODEL	TAMXA0A24V21DA	TAMXA0B30V31DA	TAMXA0C36V31DA
RATED VOLTS/PH/HZ.	200 – 230/1/60	200 – 230/1/60	200 – 230/1/60
RATINGS ^(a)	See O.D. Specifications	See O.D. Specifications	See O.D. Specifications
INDOOR COIL – Type	Plate Fin	Plate Fin	Plate Fin
Rows – F.P.I.	3 – 14	3 – 14	3 – 14
Face Area (sq. ft.)	3.67	5.04	5.50
Tube Size (in.)	3/8	3/8	3/8
Refrigerant Control	EEV	EEV	EEV
Drain Conn. Size (in.) ^(b)	3/4 NPT	3/4 NPT	3/4 NPT
DUCT CONNECTIONS	See Outline Drawing	See Outline Drawing	See Outline Drawing
INDOOR FAN – Type	Centrifugal	Centrifugal	Centrifugal
Diameter-Width (In.)	11 x 8	11 x 10	11 x 10
No. Used	1	1	1
Drive – No. Speeds	Direct – Variable	Direct – Variable	Direct – Variable
CFM vs. in. w.g.	See Fan Performance Table	See Fan Performance Table	See Fan Performance Table
No. Motors – H.P.	1 – 1/2	1 – 1/2	1 – 1/2
Motor Speed RPM	Variable ECM	Variable ECM	Variable ECM
Volts/Ph/Hz	208–230/1/60	208–230/1/60	208–230/1/60
F.L. Amps	3.0 – 3.5 ^(c)	3.0 – 3.5 ^(c)	3.0 – 3.5 ^(c)
FILTER			
Filter Furnished?	No	No	No
Type Recommended	Throwaway	Throwaway	Throwaway
No.-Size-Thickness	1 – 16 x 20 – 1 in.	1 – 20 x 20 – 1 in.	1 – 22 x 20 – 1 in.
REFRIGERANT	R-410A	R-410A	R-410A
Ref. Line Connections	Brazed	Brazed	Brazed
Coupling or Conn. Size-in. Gas	3/4	3/4	7/8
Coupling or Conn. Size-in. Liq.	3/8	3/8	3/8
DIMENSIONS	H x W x D	H x W x D	H x W x D
Crated (In.)	51 x 20 x 24.5	56.8 x 23.5 x 24.5	58 x 25.5 x 24.5
Uncrated	49.9 x 17.5 x 21.8	55.7 x 21.3 x 21.8	56.9 x 23.5 x 21.8
WEIGHT			
Shipping (Lbs.)/Net (Lbs.)	126/116	150/138	157/146

^(a) These Air Handlers are AHRI certified with various Split System Air Conditioners and Heat Pumps (AHRI STANDARD 210/240).

^(b) 3/4" Male Plastic Pipe (Ref.: ASTM 1785–76)

^(c) Check motor nameplate for actual FLA.

Product Specifications

MODEL	TAMXA0C42CV41DA	TAMXA0C48V41DA	TAMXA0C60V51DA
RATED VOLTS/PH/HZ.	200 – 230/1/60	200 – 230/1/60	200 – 230/1/60
RATINGS ^(a)	See O.D. Specifications	See O.D. Specifications	See O.D. Specifications
INDOOR COIL – Type	Plate Fin	Plate Fin	Plate Fin
Rows – F.P.I.	4 – 14	4 – 14	4 – 14
Face Area (sq. ft.)	5.04	5.96	5.96
Tube Size (in.)	3/8	3/8	3/8
Refrigerant Control	EEV	EEV	EEV
Drain Conn. Size (in.) ^(b)	3/4 NPT	3/4 NPT	3/4 NPT
DUCT CONNECTIONS	See Outline Drawing	See Outline Drawing	See Outline Drawing
INDOOR FAN – Type	Centrifugal	Centrifugal	Centrifugal
Diameter-Width (In.)	11 x 10	11 x 10	11 x 10
No. Used	1	1	1
Drive – No. Speeds	Direct – Variable	Direct – Variable	Direct – Variable
CFM vs. in. w.g.	See Fan Performance Table	See Fan Performance Table	See Fan Performance Table
No. Motors – H.P.	1 – 1/2	1 – 3/4	1 – 1
Motor Speed RPM	Variable ECM	Variable ECM	Variable ECM
Volts/Ph/Hz	208–230/1/60	208–230/1/60	208–230/1/60
F.L. Amps	3.0 – 3.5 ^(c)	5.0	6.4
FILTER			
Filter Furnished?	No	No	No
Type Recommended	Throwaway	Throwaway	Throwaway
No.-Size-Thickness	1 – 22 x 20 – 1 in.	1 – 22 x 20 – 1 in.	1 – 22 x 20 – 1 in.
REFRIGERANT	R-410A	R-410A	R-410A
Ref. Line Connections	Brazed	Brazed	Brazed
Coupling or Conn. Size-in. Gas	7/8	7/8	7/8
Coupling or Conn. Size-in. Liq.	3/8	3/8	3/8
DIMENSIONS	H x W x D	H x W x D	H x W x D
Crated (In.)	58 x 25.5 x 24.5	62.8 x 25.5 x 24.5	62.8 x 25.5 x 24.5
Uncrated	56.9 x 23.5 x 21.8	61.7 x 23.5 x 21.8	61.7 x 23.5 x 21.8
WEIGHT			
Shipping (Lbs.)/Net (Lbs.)	162/150	174/162	175/163

^(a) These Air Handlers are AHRI certified with various Split System Air Conditioners and Heat Pumps (AHRI STANDARD 210/240).

^(b) 3/4" Male Plastic Pipe (Ref.:ASTM 1785–76)

^(c) Check motor nameplate for actual FLA.

Wiring

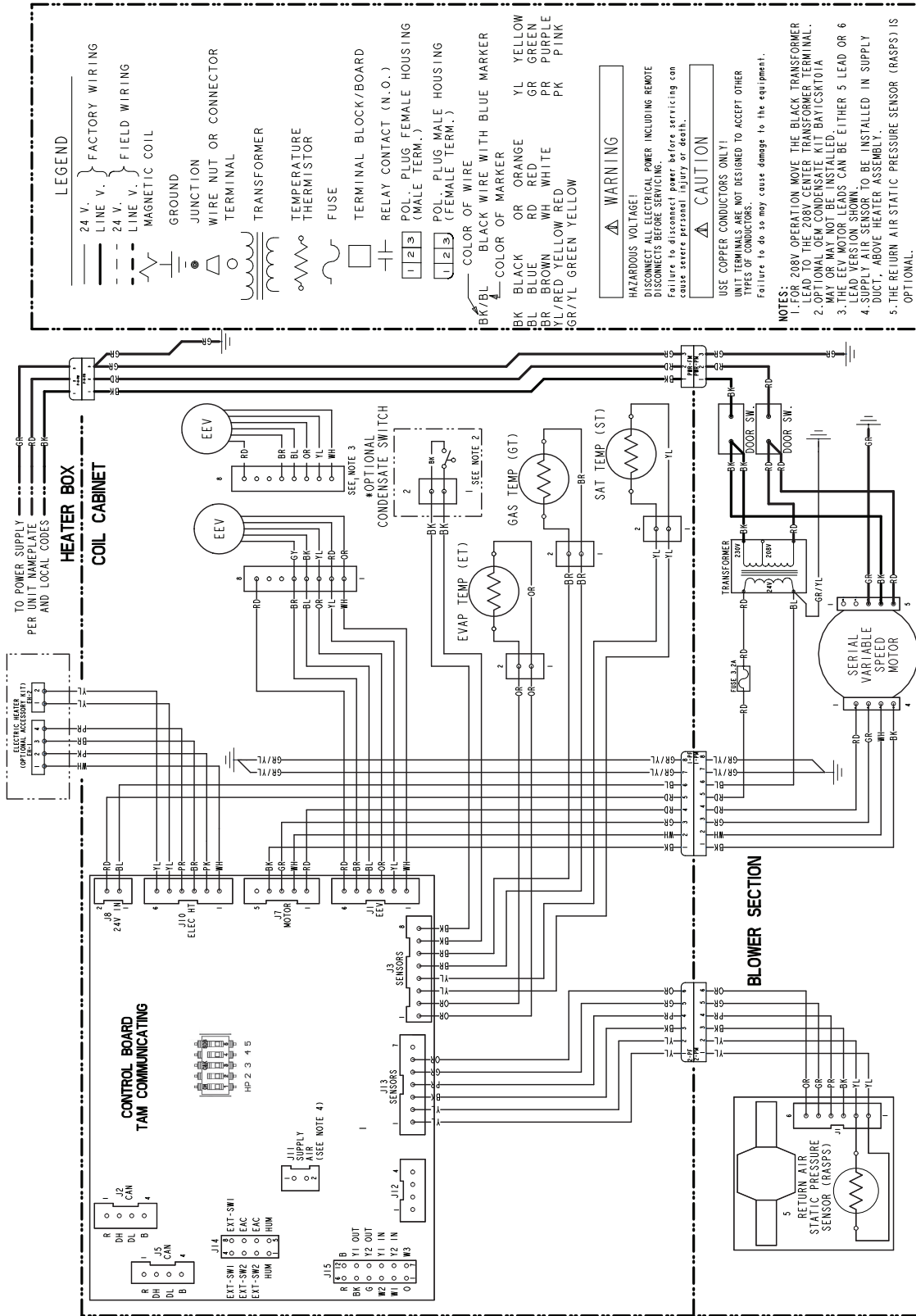

LEGEND

- 24 V. LINE V. FACTORY WIRING
- 24 V. LINE V. FIELD WIRING
- MAGNETIC COIL
- GROUND
- JUNCTION
- WIRE NUT OR CONNECTOR
- TERMINAL
- TRANSFORMER
- TEMPERATURE THERMISTOR
- FUSE
- TERMINAL BLOCK/BOARD
- RELAY CONTACT (N.O.)
- POL. PLUG FEMALE HOUSING (MALE TERM.)
- POL. PLUG MALE HOUSING (FEMALE TERM.)
- COLOR OF WIRE
- BLACK WIRE WITH BLUE MARKER
- COLOR OF MARKER
- YL YELLOW
- OR ORANGE
- RD RED
- GR GREEN
- BR BROWN
- WH WHITE
- PR PURPLE
- PK PINK
- GR/YL GREEN YELLOW

WARNING

HAZARDOUS VOLTAGE!
DISCONNECT ALL ELECTRICAL POWER INCLUDING REMOVE DISCONNECTS BEFORE SERVICING.
Failure to disconnect power before servicing can cause severe personal injury or death.

CAUTION

USE COPPER CONDUCTORS ONLY!
UNIT TERMINALS ARE NOT DESIGNED TO ACCEPT OTHER TYPES OF CONDUCTORS.
Failure to do so may cause damage to the equipment.

NOTES:

- FOR 208V OPERATION MOVE THE BLACK TRANSFORMER LEAD TO THE 208V CENTER TRANSFORMER TERMINAL.
- OPTIONAL OEM CONDENSATE KIT BAY1CSK101A MAY OR MAY NOT BE INSTALLED.
- THE EVAP MOTOR LEADS CAN BE EITHER 5 LEAD OR 6 LEAD VERSION SHOWN.
- SUPPLY AIR SENSOR TO BE INSTALLED IN SUPPLY DUCT, ABOVE HEATER ASSEMBLY.
- THE RETURN AIR STATIC PRESSURE SENSOR (RASPS) IS OPTIONAL.

PRINTED FROM: D806834P01 REV A

Sequence of Operation

Abbreviations

- AHC = Air Handler Control
- EEV = Electronic Expansion Valve

Note: When in communicating mode, the system controller (SC360) controls indoor airflow and EEV starting position.

Note: Use variable speed outdoor Sequence of Operation in conjunction with the TAMX Sequence of Operation.

The installing and servicing technician should have an understanding of the sequence of operation to be able to properly setup and diagnose functions of the air handler.

See unit, electric heat, and field wiring diagrams for additional information.

Continuous Fan

Important: If the indoor air exceeds 60% relative humidity or simply feels uncomfortably humid, it is recommended that the indoor fan only be used in the AUTO mode.

1. When a fan request is received from the thermostat, the AHC sends a command to the serial communicating blower motor to run. Airflow can be adjusted through the thermostat.
2. Humidity Control – When enabled at the thermostat, this feature will disable any blower off delays and disable continuous fan mode when the humidity is above the dehumidification set point. This will help prevent coil condensation from being evaporated back into the air stream.

Cooling Mode

1. When a request for 1st stage cooling is received, the AHC sends a command to the serial communicating blower motor to run at 1st stage cooling airflow. (Delay profiles found in the UX360 User Interface or Diagnostics Mobile App may change blower motor timing and actual airflow demand)
2. The AHC will receive input from the two temperature sensors and start to control 1st stage superheat.
3. When a request for 2nd stage cooling is received, the AHC sends a command to the serial communicating blower motor to run at 100 % cooling airflow.
4. The AHC will now control superheat for 2nd stage.

5. When a request for cooling is removed, the AHC will turn off the blower motor after any user selected fan-off delays have expired.

Note: Delay profiles found in the UX360 User Interface or Diagnostics Mobile App may change blower motor timing and actual airflow demand.

Heat pump (compressor only)

1. When a request for 1st stage heat is received, the AHC sends a command to the serial communicating blower motor to run at 1st stage heating airflow.
2. The AHC will drive the EEV to the heating position and refrigerant will flow in the reverse cycle.
3. When a request for 2nd stage mechanical heat is received, the AHC sends a command to the serial communicating blower motor to run at 100 % heating airflow.
4. When a request for heat pump is removed, the AHC will turn off the blower motor after any user selected fan-off delays have expired.

Note: Delay profiles found in the UX360 User Interface or Diagnostics Mobile App may change blower motor timing and actual airflow demand.

Electric Heat

1. When a request for electric heat is received, the AHC will energize the on board 24 volt relays per the amount of heat requested from the thermostat and the size of the heater installed.
2. The AHC sends a command to the serial communicating blower motor to run proper airflow and close the blower interlock relay on the AHC.

Hydronic Heat

1. When a request for hydronic heat is received, the AHC will energize the on board W1 relay.
2. The AHC sends a command to the serial communicating blower motor to run at the requested CFM.

Defrost

1. The OD unit will initiate defrost and send a message to the AHC.
2. The AHC will communicate to the EEV that the OD is in defrost and the EEV will start to control the correct superheat.
3. Electric or hydronic heat will be energized to help temper the air.

Freeze Protection

1. The AHC control has the ability to sense when the indoor coil is beginning to ice. If this event should occur, the AHC will send a message to de-energize the OD unit.
2. The indoor blower motor will continue running to aid in defrosting the coil.
3. After 5 minutes, the OD will be turned back on.

TAMX Air Flow Performance Tables

OUTDOOR MULTIPLIER (TONS)	TAMXA0A24 AIRFLOW PERFORMANCE										CONSTANT CFM MODE / CONSTANT TORQUE MODE													
	EXTERNAL STATIC PRESSURE (Constant CFM/ Constant Torque)					HEATING AIRFLOW SETTING					AIRFLOW POWER					EXTERNAL STATIC PRESSURE								
	0.1	0.3	0.5	0.7	0.9	290	350	400	450	290	350	400	450	290	350	400	450	0.1	0.3	0.5	0.7	0.9		
1.5 tons	CFM	407/546	430/403	398/NA	347/NA	255/NA	290	CFM	416	426	401	330	291	CFM	416	426	401	330	291	CFM	416	426	401	330
	Watts	22/40	51/48	77/NA	103/NA	133/NA	CFM/ton	Watts	22	49	76	101	134	CFM/ton	22	49	76	101	134	CFM/ton	22	49	76	101
	CFM	534/630	549/531	542/360	509/NA	445/NA	350	CFM	532	550	542	507	434	CFM	532	550	542	507	434	CFM	532	550	542	507
	Watts	39/57	71/68	103/73	132/NA	156/NA	CFM/ton	Watts	37	69	101	129	152	CFM/ton	37	69	101	129	152	CFM/ton	37	69	101	129
	CFM	617/697	633/617	632/501	604/NA	559/NA	400	CFM	660	680	679	658	614	CFM	660	680	679	658	614	CFM	660	680	679	658
	Watts	54/72	90/86	125/96	156/NA	181/NA	CFM/ton	Watts	62	99	136	169	197	CFM/ton	62	99	136	169	197	CFM/ton	62	99	136	169
	CFM	691/762	710/693	707/602	688/478	649/NA	450	CFM	690	710	709	690	651	CFM	690	710	709	690	651	CFM	690	710	709	690
	Watts	72/91	111/106	148/119	183/127	212/NA	CFM/ton	Watts	69	108	145	180	208	CFM/ton	69	108	145	180	208	CFM/ton	69	108	145	180
	CFM	593/680	613/595	607/470	583/208	527/132	290	CFM	593	613	608	582	527	CFM	593	613	608	582	527	CFM	593	613	608	582
	Watts	54/68	85/81	119/90	150/94	175/138	CFM/ton	Watts	48	82	116	147	172	CFM/ton	48	82	116	147	172	CFM/ton	48	82	116	147
2 tons †	CFM	717/783	733/717	733/632	714/519	678/355	350	CFM	714	734	734	716	679	CFM	714	734	734	716	679	CFM	714	734	734	
	Watts	79/98	118/114	157/127	192/136	222/143	CFM/ton	Watts	75	115	153	189	218	CFM/ton	75	115	153	189	218	CFM/ton	75	115	153	
	CFM	810/868	827/811	827/740	813/652	782/543	400 †	CFM	862	881	884	874	849	CFM	862	881	884	874	849	CFM	862	881	884	
	Watts	108/128	152/146	194/161	233/173	265/182	CFM/ton	Watts	122	168	213	254	290	CFM/ton	122	168	213	254	290	CFM/ton	122	168	213	
	CFM	903/954	918/902	920/839	909/764	884/674	450	CFM	899	917	921	889	889	CFM	899	917	921	889	889	CFM	899	917	921	
	Watts	144/165	192/182	238/201	280/215	316/224	CFM/ton	Watts	136	184	231	273	310	CFM/ton	136	184	231	273	310	CFM/ton	136	184	231	
	CFM	741/820	757/759	757/681	739/582	705/452	290	CFM	738	757	758	742	707	CFM	738	757	758	742	707	CFM	738	757	758	
	Watts	86/110	126/127	166/141	202/152	232/159	CFM/ton	Watts	81	122	162	198	229	CFM/ton	81	122	162	198	229	CFM/ton	81	122	162	
	CFM	880/947	896/895	896/832	885/757	859/665	350	CFM	876	895	898	888	864	CFM	876	895	898	888	864	CFM	876	895	898	
	Watts	134/162	182/181	226/198	267/211	302/221	CFM/ton	Watts	127	174	220	261	297	CFM/ton	127	174	220	261	297	CFM/ton	127	174	220	
2.5 tons	CFM	996/1059	1011/1011	1014/954	1006/887	985/807	400	CFM	1064	1083	1089	1084	1066	CFM	1064	1083	1089	1084	1066	CFM	1064	1083	1089	
	Watts	188/220	241/240	291/257	336/271	375/280	CFM/ton	Watts	215	272	326	375	418	CFM/ton	215	272	326	375	418	CFM/ton	215	272	326	
	CFM	1120/1135	1137/1137	1137/1081	1129/1019	1108/946	450	CFM	1115	1133	1139	1133	1116	CFM	1115	1133	1139	1133	1116	CFM	1115	1133	1139	
	Watts	260/297	319/317	373/334	422/347	463/355	CFM/ton	Watts	244	304	360	410	453	CFM/ton	244	304	360	410	453	CFM/ton	244	304	360	
	CFM	875/943	891/891	892/891	880/751	854/659	290	CFM	871	890	894	883	859	CFM	871	890	894	883	859	CFM	871	890	894	
	Watts	132/160	179/179	224/196	265/209	300/211	CFM/ton	Watts	125	172	217	259	295	CFM/ton	125	172	217	259	295	CFM/ton	125	172	217	
	CFM	1045/1060	1060/1060	1063/1004	1055/939	1035/862	350	CFM	1040	1058	1064	1059	1041	CFM	1040	1058	1064	1059	1041	CFM	1040	1058	1064	
	Watts	215/248	270/268	321/285	369/299	409/308	CFM/ton	Watts	202	257	310	358	401	CFM/ton	202	257	310	358	401	CFM/ton	202	257	310	
	CFM	1200/1212	1212/1212	1212/1159	1200/1099	1129/1030	400	CFM	1291	1302	1300	1220	1138	CFM	1291	1302	1300	1220	1138	CFM	1291	1302	1300	
	Watts	315/354	376/374	432/390	480/402	481/409	CFM/ton	Watts	368	432	487	478	470	CFM/ton	368	432	487	478	470	CFM/ton	368	432	487	
3 tons	CFM	1358/1403	1333/1359	1256/1308	1177/1251	1095/1187	450	CFM	1355	1360	1286	1208	1128	CFM	1355	1360	1286	1208	1128	CFM	1355	1360	1286	
	Watts	447/484	482/502	472/517	466/527	460/531	CFM/ton	Watts	422	483	476	468	462	CFM/ton	422	483	476	468	462	CFM/ton	422	483	476	
	CFM	1120/1135	1137/1137	1137/1081	1129/1019	1108/946	450	CFM	1115	1133	1139	1133	1116	CFM	1115	1133	1139	1133	1116	CFM	1115	1133	1139	
	Watts	260/297	319/317	373/334	422/347	463/355	CFM/ton	Watts	244	304	360	410	453	CFM/ton	244	304	360	410	453	CFM/ton	244	304	360	
	CFM	875/943	891/891	892/891	880/751	854/659	290	CFM	871	890	894	883	859	CFM	871	890	894	883	859	CFM	871	890	894	
	Watts	132/160	179/179	224/196	265/209	300/211	CFM/ton	Watts	125	172	217	259	295	CFM/ton	125	172	217	259	295	CFM/ton	125	172	217	
	CFM	1045/1060	1060/1060	1063/1004	1055/939	1035/862	350	CFM	1040	1058	1064	1059	1041	CFM	1040	1058	1064	1059	1041	CFM	1040	1058	1064	
	Watts	215/248	270/268	321/285	369/299	409/308	CFM/ton	Watts	202	257	310	358	401	CFM/ton	202	257	310	358	401	CFM/ton	202	257	310	
	CFM	1200/1212	1212/1212	1212/1159	1200/1099	1129/1030	400	CFM	1291	1302	1300	1220	1138	CFM	1291	1302	1300	1220	1138	CFM	1291	1302	1300	
	Watts	315/354	376/374	432/390	480/402	481/409	CFM/ton	Watts	368	432	487	478	470	CFM/ton	368	432	487	478	470	CFM/ton	368	432	487	

- † Factory Setting
- Status LED will blink once per 100 CFM requested. In torque mode, actual airflow may be lower.
- Torque mode will reduce airflow when static is above approximately 0.3" water column.
- All heating modes default to Constant CFM.
- Cooling airflow values are with wet coil, no filter

TAMXA0A24 Minimum Heating Airflow Settings

MODEL NO.	BAYEAAC08BK1 BAYEAAC08LG1	BAYEAAC10BK1 BAYEAAC10LG1	BAYEAAC10LG3	BAYEABC15BK1 BAYEABC15LG3	BAYEABC20BK1
TAMXA0A24	638/900	675/900	600/713	-	-

WITHOUT HEAT PUMP / WITH HP — SEE AIR HANDLER NAMEPLATE FOR APPROVED COMBINATIONS

(e) Factory heating default setting is 430 CFM/ton

TAMXA0B30 AIRFLOW PERFORMANCE / CONSTANT CFM MODE / CONSTANT TORQUE MODE												
OUTDOOR MULTIPLIER (TONS)	EXTERNAL STATIC PRESSURE (Constant CFM / Constant Torque)			AIRFLOW POWER	COOLING AIRFLOW SETTING	HEATING AIRFLOW SETTING	AIRFLOW POWER	EXTERNAL STATIC PRESSURE				
	0.1	0.3	0.5					0.7	0.9	0.1	0.3	0.5
1.5 tons	290 CFM/ton	492/581	442/397	408/NA	353/NA	221/NA	290 CFM/ton	485	437	393	349	300
	350 CFM/ton	576/664	553/515	527/NA	493/NA	472/NA	350 CFM/ton	574	545	517	489	457
	400 CFM/ton	644/730	633/598	612/403	590/NA	563/NA	400 CFM/ton	643	624	605	583	559
	450 CFM/ton	711/794	708/673	691/510	678/NA	656/NA	450 CFM/ton	709	698	684	669	649
	290 CFM/ton	47/60	83/77	118/86	154/NA	189/NA	290 CFM/ton	45	80	115	151	186
2 tons †	350 CFM/ton	627/713	611/576	589/369	568/NA	542/NA	350 CFM/ton	625	603	582	559	533
	400 † CFM/ton	734/815	730/698	717/541	705/NA	684/NA	400 † CFM/ton	731	722	710	696	677
	450 CFM/ton	822/898	824/792	817/657	811/NA	797/NA	450 † CFM/ton	817	815	811	801	788
	400 † CFM/ton	66/81	107/101	149/112	191/NA	231/NA	400 † CFM/ton	63	103	145	186	226
	450 CFM/ton	910/982	916/884	916/763	914/610	904/NA	450 CFM/ton	902	907	908	904	895
2.5 tons	290 CFM/ton	85/102	131/123	178/136	226/140	270/NA	290 CFM/ton	80	126	172	219	263
	350 CFM/ton	755/860	753/749	742/606	732/397	712/NA	350 CFM/ton	753	745	735	723	706
	400 † CFM/ton	54/73	92/91	130/102	168/104	205/NA	400 † CFM/ton	52	88	126	164	201
	450 CFM/ton	887/985	893/887	891/767	888/614	876/NA	450 CFM/ton	881	884	884	879	868
	400 CFM/ton	80/102	125/124	170/137	217/141	260/NA	400 CFM/ton	75	120	165	210	253
3 tons	290 CFM/ton	998/1094	1010/1003	1017/895	1018/765	1008/NA	290 CFM/ton	989	1001	1008	1008	1000
	350 CFM/ton	107/134	160/158	213/173	266/179	315/NA	350 CFM/ton	100	152	205	257	306
	400 CFM/ton	1116/1212	1135/1126	1147/1027	1148/911	1134/NA	400 CFM/ton	1104	1124	1136	1139	1128
	450 CFM/ton	143/176	205/201	267/219	325/227	376/NA	450 CFM/ton	133	194	255	314	366
	290 CFM/ton	883/981	888/882	887/762	881/608	870/NA	290 CFM/ton	877	880	879	874	863
3 tons	350 CFM/ton	79/101	124/122	169/136	214/140	257/NA	350 CFM/ton	74	118	164	208	252
	400 CFM/ton	1043/1140	1059/1051	1068/947	1069/823	1059/NA	400 CFM/ton	1034	1049	1058	1061	1053
	450 CFM/ton	120/150	177/174	233/190	288/197	339/NA	450 CFM/ton	112	168	224	279	330
	290 CFM/ton	1190/1304	1214/1221	1226/1126	1223/1016	1201/886	290 CFM/ton	1177	1201	1215	1215	1198
	350 CFM/ton	170/203	238/231	304/251	364/261	414/261	350 CFM/ton	157	224	291	352	403
TAMXA0B30	450 CFM/ton	1355/1471	1376/1391	1375/1302	1353/1201	1296/1086	450 CFM/ton	1338	1363	1368	1350	1314
	241/282	318/311	386/333	441/345	472/345	472/345	241/282	221	299	369	427	472
<ul style="list-style-type: none"> † Factory Setting Status LED will blink once per 100 CFM requested. In torque mode, actual airflow may be lower. Torque mode will reduce airflow when static is above approximately 0.35" water column. All heating modes default to Constant CFM. Cooling airflow values are with wet coil, no filter 												
TAMXA0B30 Minimum Heating Airflow Settings												
MODEL NO.	BAYEAC04BK1 BAYEAC04LG1 BAYEAC05BK1 BAYEAC05LG1	BAYEAC08BK1 BAYEAC08LG1	BAYEAC10BK1 BAYEAC10LG1	BAYEAC10LG3	BAYEABC15BK1	BAYEABC15LG3	BAYEABC20BK1					
TAMXA0B30	723/808	723/1020	765/1020	680/808	765/1063	850/1105	-					
WITHOUT HEAT PUMP / WITH HP — SEE AIR HANDLER NAMEPLATE												

(e) Factory heating default setting is 430 CFM/ton

TAMX Air Flow Performance Tables

TAMXA0C36 AIRFLOW PERFORMANCE CONSTANT CFM MODE / CONSTANT TORQUE MODE														
OUTDOOR MULTIPLIER (TONS)	COOLING AIRFLOW SETTING	AIRFLOW POWER	EXTERNAL STATIC PRESSURE (Constant CFM / Constant Torque)					HEATING AIRFLOW SETTING	AIRFLOW POWER	EXTERNAL STATIC PRESSURE				
			0.1	0.3	0.5	0.7	0.9			0.1	0.3	0.5	0.7	0.9
2 tons	290 CFM/ton	CFM Watts	605/747 31/48	573/565 59/58	553/306 88/62	548/NA 120/NA	546/NA 153/NA	290 CFM/ton	CFM Watts	606 31	574 58	557 87	551 119	549 152
	370 CFM/ton	CFM Watts	755/880 50/70	745/738 85/85	737/575 121/93	738/367 160/97	735/NA 197/NA	350 CFM/ton	CFM Watts	720 43	705 77	695 111	694 148	691 184
	400 CFM/ton	CFM Watts	810/929 58/80	804/797 97/96	800/650 136/106	802/478 176/111	802/231 216/120	400 CFM/ton	CFM Watts	810 56	805 95	800 134	803 174	802 214
	450 CFM/ton	CFM Watts	900/1011 75/98	900/893 118/117	902/764 162/129	905/624 207/136	906/462 251/140	450 CFM/ton	CFM Watts	900 72	900 115	903 159	906 204	907 248
	290 CFM/ton	CFM Watts	742/891 48/72	729/752 82/87	722/592 118/96	721/394 155/99	720/NA 193/NA	290 CFM/ton	CFM Watts	742 46	731 81	722 117	722 154	720 191
2.5 tons	370 CFM/ton	CFM Watts	922/1055 80/109	923/942 124/128	927/820 170/142	930/690 215/150	931/546 260/154	350 CFM/ton	CFM Watts	877 68	877 110	876 152	880 196	880 239
	400 CFM/ton	CFM Watts	989/1118 95/127	995/1012 143/148	1002/899 193/163	1008/779 242/173	1010/652 290/177	400 CFM/ton	CFM Watts	989 90	995 139	1000 188	1008 258	1008 285
	450 CFM/ton	CFM Watts	1103/1228 125/162	1117/1131 181/185	1129/1028 238/203	1137/921 294/215	1137/809 346/221	450 CFM/ton	CFM Watts	1102 119	1116 175	1127 231	1137 288	1138 340
	290 CFM/ton	CFM Watts	872/1009 70/97	871/890 111/116	871/761 154/128	874/620 197/135	874/457 240/139	290 CFM/ton	CFM Watts	871 67	872 109	871 151	874 195	875 237
	370 CFM/ton	CFM Watts	1089/1214 121/157	1102/1116 176/180	1114/1013 232/198	1122/905 287/209	1122/791 339/215	350 CFM/ton	CFM Watts	1033 101	1043 152	1051 204	1059 257	1061 307
3 tons †	400 CFM/ton	CFM Watts	1175/1298 147/188	1193/1205 208/212	1208/1107 270/231	1215/1006 329/244	1211/899 382/251	400 CFM/ton	CFM Watts	1171 139	1191 200	1205 262	1215 322	1212 376
	450 CFM/ton	CFM Watts	1329/1447 204/253	1353/1361 276/279	1366/1270 345/299	1363/1176 406/313	1343/1077 456/321	450 CFM/ton	CFM Watts	1324 192	1349 264	1364 334	1364 396	1347 448
	290 CFM/ton	CFM Watts	1002/1131 98/130	1009/1026 147/152	1017/914 198/167	1023/797 248/177	1024/671 296/182	290 CFM/ton	CFM Watts	997 92	1010 143	1016 197	1022 248	1027 293
	370 CFM/ton	CFM Watts	1270/1391 181/227	1293/1302 249/252	1308/1210 316/272	1311/1113 377/286	1297/1012 429/293	350 CFM/ton	CFM Watts	1196 146	1217 210	1231 272	1241 334	1234 387
	400 CFM/ton	CFM Watts	1383/1499 227/278	1407/1414 303/305	1416/1325 372/325	1406/1233 431/340	1380/1136 478/348	400 CFM/ton	CFM Watts	1379 214	1404 289	1415 360	1330 378	1390 473
3.5 tons	450 CFM/ton	CFM Watts	1579/1669 326/375	1583/1587 402/402	1567/1502 464/423	1474/1413 475/437	1357/1320 468/444	450 CFM/ton	CFM Watts	1499 268	1508 342	1586 460	1504 478	1390 472
	<ul style="list-style-type: none"> † Factory Setting Status LED will blink once per 100 CFM requested. In torque mode, actual airflow may be lower. Torque mode will reduce airflow when static is above approximately 0.35" water column. All heating modes default to Constant CFM. Cooling airflow values are with wet coil, no filter 													

TAMXA0C36 Minimum Heating Airflow Settings

MODEL NO.	BAYEAC04BK1 BAYEAC04LG1 BAYEAC05BK1 BAYEAC05LG1	BAYEAC08BK1 BAYEAC08LG1	BAYEAC10BK1 BAYEAC10LG1	BAYEAC10LG3	BAYEABC15BK1	BAYEACB15LG3	BAYEABC20BK1
TAMXA0C36	876/979	876/1236	927/1236	824/979	927/1288	1030/1339	1236/1442
WITHOUT HEAT PUMP / WITH HP — SEE AIR HANDLER NAMEPLATE							

(e) Factory heating default setting is 420 CFM/ton

TAMXA0C42 AIRFLOW PERFORMANCE CONSTANT CFM MODE / CONSTANT TORQUE MODE														
OUTDOOR MULTIPLIER (TONS)	COOLING AIRFLOW SETTING	AIRFLOW POWER	EXTERNAL STATIC PRESSURE (Constant CFM / Constant Torque)				HEATING AIRFLOW SETTING	AIRFLOW POWER	EXTERNAL STATIC PRESSURE					
			0.1	0.3	0.5	0.7			0.9	0.1	0.3	0.5	0.7	0.9
2.5 tons	290 CFM/ton	CFM Watts	747/905 48/77	743/764 87/94	742/591 127/102	741/342 168/106	739/NA 207/NA	290 CFM/ton	CFM Watts	744 51	741 90	740 130	738 170	734 209
	370 CFM/ton	CFM Watts	937/1072 80/118	942/956 129/139	946/823 179/151	947/655 227/155	944/458 273/155	350 CFM/ton	CFM Watts	889 76	892 123	894 169	894 215	890 259
	400 CFM/ton	CFM Watts	1006/1136 95/138	1014/1027 148/159	1020/903 201/173	1022/760 253/178	1019/586 302/177	400 CFM/ton	CFM Watts	1006 103	1016 156	1018 209	1019 160	1016 308
	450 CFM/ton	CFM Watts	1122/1247 125/176	1135/1146 185/200	1143/1035 245/216	1146/911 303/224	1142/768 357/223	450 CFM/ton	CFM Watts	1124 136	1135 196	1142 256	1144 313	1140 366
		CFM Watts	885/1026 70/106	889/904 116/125	891/763 163/136	892/590 209/139	889/341 254/143	290 CFM/ton	CFM Watts	884 75	887 121	889 168	889 214	885 257
		CFM Watts	1108/1233 121/171	1120/1132 181/195	1128/1019 240/210	1131/893 297/218	1128/747 350/217	350 CFM/ton	CFM Watts	1053 115	1062 171	1067 227	1069 280	1066 330
3 tons	400 CFM/ton	CFM Watts	1194/1316 147/204	1208/1220 212/229	1218/1115 276/246	1221/999 337/255	1215/868 393/256	400 CFM/ton	CFM Watts	1196 160	1209 225	1218 289	1219 349	1212 403
	450 CFM/ton	CFM Watts	1343/1463 200/272	1361/1374 275/300	1371/1279 348/320	1368/1175 413/331	1352/1061 469/334	450 CFM/ton	CFM Watts	1347 220	1363 295	1371 367	1366 430	1342 480
	290 CFM/ton	CFM Watts	1020/1149 99/142	1028/1041 152/164	1034/919 206/178	1037/779 259/183	1034/609 308/182	290 CFM/ton	CFM Watts	1020 107	1028 160	1033 214	1033 277	1031 315
3.5 tons †	370 † CFM/ton	CFM Watts	1287/1408 179/245	1304/1317 250/272	1314/1218 320/291	1315/1110 384/301	1304/981 441/303	350 CFM/ton	CFM Watts	1220 169	1234 236	1243 301	1244 362	1236 417
	400 CFM/ton	CFM Watts	1395/1514 221/299	1413/1427 300/328	1421/1334 374/348	1415/1233 440/361	1369/1124 480/364	400 † CFM/ton	CFM Watts	1440 244	1416 322	1421 395	1411 458	1355 475
	450 CFM/ton	CFM Watts	1584/1687 313/405	1593/1605 399/435	1576/1518 467/458	1474/1425 477/472	1350/1326 468/477	450 CFM/ton	CFM Watts	1589 347	1592 428	1545 474	1434 473	1315 463
	290 CFM/ton	CFM Watts	1156/1302 135/197	1169/1205 197/222	1178/1098 259/239	1181/981 319/248	1174/848 383/249	290 CFM/ton	CFM Watts	1157 147	1169 209	1177 271	1179 330	1174 383
	370 CFM/ton	CFM Watts	1487/1618 288/359	1500/1534 369/389	1496/1445 441/411	1445/1350 481/425	1319/1248 470/429	350 CFM/ton	CFM Watts	1400 244	1416 322	1421 395	1411 458	1335 475
	400 CFM/ton	CFM Watts	1616/1728 363/433	1614/1646 443/464	1543/1543 475/475	1423/1423 472/472	1301/1301 463/463	400 CFM/ton	CFM Watts	1615 363	1615 444	1545 474	1431 471	1313 462
4 tons	450 CFM/ton	CFM Watts	1711/1711 432/432	1621/1621 456/456	1514/1514 465/465	1393/1393 460/460	1273/1273 453/453	450 CFM/ton	CFM Watts	1716 430	1629 453	1528 462	1411 458	1297 452

- † Factory Setting
- Status LED will blink once per 100 CFM requested. In torque mode, actual airflow may be lower.
- Torque mode will reduce airflow when static is above approximately 0.35" water column.
- All heating modes default to Constant CFM.
- Cooling airflow values are with wet coil, no filter

TAMXA0C42 Minimum Heating Airflow Settings

MODEL NO.	BAYEAC04BK1 BAYEAC04LG1 BAYEAC05BK1 BAYEAC05LG1	BAYEAC08BK1 BAYEAC08LG1	BAYEAC10BK1 BAYEAC10LG1	BAYEAC10LG3	BAYEABC15BK1	BAYEACB15LG3	BAYEABC20BK1
TAMXA0C42	978/1093	978/1380	1035/1380	920/1093	1035/1438	1150/1495	1380/1610
WITHOUT HEAT PUMP / WITH HP — SEE AIR HANDLER NAMEPLATE							

TAMX Air Flow Performance Tables

TAMXA0C48 AIRFLOW PERFORMANCE / CONSTANT CFM MODE / CONSTANT TORQUE MODE												
OUTDOOR MULTIPLIER (TONS)	COOLING AIRFLOW SETTING	AIRFLOW POWER	EXTERNAL STATIC PRESSURE (Constant CFM / Constant Torque)				HEATING AIRFLOW SETTING	AIRFLOW POWER	EXTERNAL STATIC PRESSURE			
			0.1	0.3	0.5	0.7			0.9	0.1	0.3	0.5
3 tons	290 CFM/ton	CFM Watts	894 / 1018 69 / 91	900 / 897 114 / 114	896 / 767 157 / 130	886 / 622 195 / 137	871 / 445 229 / 136	290 CFM/ton	CFM Watts	893 / 900 72 / 118	893 / 883 159 / 197	864 / 230
	350 CFM/ton	CFM Watts	1067 / 1180 106 / 132	1073 / 1078 158 / 160	1072 / 972 208 / 180	1065 / 859 252 / 192	1053 / 738 292 / 194	350 CFM/ton	CFM Watts	1068 / 1073 112 / 164	1070 / 1062 213 / 257	1049 / 295
	400 CFM/ton	CFM Watts	1205 / 1314 145 / 176	1212 / 1222 203 / 206	1213 / 1128 259 / 229	1208 / 1029 309 / 244	1199 / 926 354 / 249	400 CFM/ton	CFM Watts	1207 / 1212 154 / 212	1212 / 1206 266 / 315	1196 / 359
	450 CFM/ton	CFM Watts	1343 / 1451 193 / 232	1352 / 1367 259 / 264	1353 / 1280 320 / 289	1353 / 1190 377 / 305	1346 / 1098 427 / 313	450 CFM/ton	CFM Watts	1344 / 1344 206 / 270	1352 / 1352 331 / 387	1344 / 436
	290 CFM/ton	CFM Watts	1034 / 1149 98 / 123	1041 / 1044 149 / 150	1038 / 934 197 / 170	1031 / 817 240 / 181	1018 / 690 279 / 182	290 CFM/ton	CFM Watts	1034 / 1034 103 / 154	1037 / 1028 202 / 244	1014 / 281
	350 CFM/ton	CFM Watts	1228 / 1336 152 / 185	1235 / 1246 212 / 215	1236 / 1153 268 / 238	1232 / 1056 319 / 253	1224 / 955 365 / 259	350 CFM/ton	CFM Watts	1229 / 1235 162 / 221	1236 / 1230 276 / 326	1220 / 371
	400 CFM/ton	CFM Watts	1389 / 1498 212 / 253	1399 / 1415 280 / 286	1403 / 1331 343 / 311	1401 / 1244 402 / 328	1395 / 1154 455 / 336	400 CFM/ton	CFM Watts	1392 / 1400 226 / 293	1403 / 1400 356 / 413	1394 / 465
	450 CFM/ton	CFM Watts	1558 / 1669 290 / 343	1570 / 1592 367 / 377	1575 / 1514 439 / 404	1575 / 1434 505 / 422	1568 / 1351 563 / 432	450 CFM/ton	CFM Watts	1561 / 1572 310 / 386	1576 / 1574 457 / 521	1567 / 577
	290 CFM/ton	CFM Watts	1168 / 1298 133 / 170	1175 / 1205 191 / 200	1175 / 1109 244 / 223	1170 / 1010 293 / 237	1160 / 905 336 / 242	290 CFM/ton	CFM Watts	1168 / 1168 141 / 198	1174 / 1168 251 / 299	1157 / 341
	350 † CFM/ton	CFM Watts	1389 / 1517 212 / 262	1399 / 1436 280 / 295	1403 / 1352 343 / 321	1401 / 1266 402 / 338	1395 / 1177 455 / 346	350 CFM/ton	CFM Watts	1392 / 1400 226 / 293	1403 / 1400 356 / 413	1394 / 465
400 CFM/ton	CFM Watts	1583 / 1714 303 / 370	1595 / 1639 382 / 546	1601 / 1562 455 / 431	1600 / 1483 521 / 450	1593 / 1401 580 / 459	400 † CFM/ton	CFM Watts	1586 / 1597 325 / 402	1601 / 1599 474 / 538	1591 / 595	
450 CFM/ton	CFM Watts	1790 / 1918 429 / 511	1800 / 184 8515 / 546	1808 / 1775 594 / 573	1793 / 1701 663 / 592	1698 / 1625 660 / 601	450 CFM/ton	CFM Watts	1794 / 1801 459 / 544	1800 / 1766 620 / 665	1667 / 655	
290 CFM/ton	CFM Watts	1301 / 1429 177 / 222	1310 / 1344 241 / 253	1312 / 1256 300 / 278	1309 / 1165 355 / 294	1302 / 1071 404 / 302	290 CFM/ton	CFM Watts	1302 / 1310 189 / 252	1310 / 1310 310 / 355	1309 / 403	
350 CFM/ton	CFM Watts	1558 / 1688 290 / 354	1570 / 1613 367 / 389	1575 / 1535 439 / 415	1575 / 1455 505 / 434	1568 / 1373 563 / 444	350 CFM/ton	CFM Watts	1557 / 1570 290 / 367	1575 / 1575 439 / 505	1569 / 563	
400 CFM/ton	CFM Watts	1790 / 1918 429 / 511	1800 / 1848 515 / 546	1801 / 1775 594 / 573	1793 / 1701 663 / 592	1698 / 1625 660 / 601	400 CFM/ton	CFM Watts	1789 / 1799 428 / 515	1801 / 1794 663 / 659	1701 / 659	
450 CFM/ton	CFM Watts	2018 / 2018 605 / 605	1973 / 1973 656 / 656	1857 / 1857 645 / 645	1749 / 1749 637 / 637	1651 / 1651 631 / 631	450 CFM/ton	CFM Watts	2018 / 1975 605 / 656	1863 / 1757 643 / 634	1660 / 628	
<ul style="list-style-type: none"> † Factory Setting ** Not an actual OD size Status LED will blink once per 100 CFM requested. In torque mode, actual airflow may be lower. Torque mode will reduce airflow when static is above approximately 0.4" water column. 												
TAMXA0C48 Minimum Heating Airflow Settings												
MODEL NO.	BAYEAAC04BK1 BAYEAAC04LG1 BAYEAAC05BK1 BAYEAAC05LG1	BAYEAAC08BK1 BAYEAAC08LG1	BAYEAAC10BK1 BAYEAAC10LG1	BAYEAAC10LG3	BAYEABC15BK1	BAYEACB15LG3	BAYEABC20BK1	BAYEACC25BK1				
TAMXA0C48	1063 / 1188	1063 / 1500	1125 / 1500	1000 / 1188	1125 / 1563	1250 / 1625	1500 / 1750	1625 / 1813				
WITHOUT HEAT PUMP / WITH HP — SEE AIR HANDLER NAMEPLATE												

OUTDOOR MULTIPLIER (TONS)	TAMXA0C60 AIRFLOW PERFORMANCE										CONSTANT CFM MODE / CONSTANT TORQUE MODE									
	EXTERNAL STATIC PRESSURE (Constant CFM / Constant Torque)					HEATING AIRFLOW SETTING					AIRFLOW POWER					EXTERNAL STATIC PRESSURE				
	0.1	0.3	0.5	0.7	0.9	290 CFM/ton	350 CFM/ton	400 CFM/ton	450 CFM/ton	290 Watts	350 Watts	400 Watts	450 Watts	0.1	0.3	0.5	0.7	0.9		
3.5 tons	1040 / 1151	1068 / 1056	1075 / 941	1066 / 799	1046 / 607	290	350	400	450	290	350	400	450	1039	1065	1071	1063	1045		
	94 / 119	151 / 148	203 / 168	247 / 175	283 / 165	CFM	CFM	CFM	CFM	Watts	Watts	Watts	Watts	95	151	203	247	283		
	1312 / 1343	1332 / 1264	1336 / 1174	1329 / 1068	1314 / 945	370	400	450	290	350	400	450	1247	1266	1270	1263	1248			
	171 / 178	236 / 210	296 / 235	349 / 250	392 / 251	CFM/ton	CFM/ton	CFM/ton	CFM/ton	CFM/ton	CFM/ton	CFM/ton	CFM/ton	150	213	270	321	363		
	1408 / 1496	1425 / 1426	1429 / 1346	1423 / 1256	1410 / 1154	400	450	290	350	400	450	1407	1423	1426	1421	1409				
	206 / 238	274 / 273	337 / 301	393 / 319	440 / 325	CFM/ton	CFM/ton	CFM/ton	CFM/ton	CFM/ton	CFM/ton	CFM/ton	CFM/ton	206	274	337	392	439		
	1565 / 1650	1579 / 1585	1584 / 1512	1580 / 1432	1569 / 1343	450	290	350	400	450	1564	1578	1582	1578	1569					
	274 / 312	348 / 348	416 / 378	477 / 398	529 / 407	CFM/ton	CFM/ton	CFM/ton	CFM/ton	CFM/ton	CFM/ton	CFM/ton	CFM/ton	274	348	416	476	529		
	1186 / 1304	1208 / 1223	1213 / 1128	1206 / 1018	1189 / 887	290	350	400	450	290	350	400	450	1185	1206	1210	1203	1187		
	131 / 164	192 / 196	248 / 220	297 / 234	337 / 233	CFM/ton	CFM/ton	CFM/ton	CFM/ton	CFM/ton	CFM/ton	CFM/ton	CFM/ton	131	192	248	297	337		
4 tons	1480 / 1514	1495 / 1444	1499 / 1365	1495 / 1277	1482 / 1177	370	400	450	290	350	400	450	1407	1423	1426	1421	1409			
	235 / 245	306 / 280	372 / 308	430 / 327	479 / 334	CFM/ton	CFM/ton	CFM/ton	CFM/ton	CFM/ton	CFM/ton	CFM/ton	CFM/ton	206	274	337	392	439		
	1587 / 1689	1602 / 1625	1606 / 1554	1602 / 1475	1592 / 1399	400	450	290	350	400	450	1587	1600	1604	1601	1592				
	285 / 332	360 / 369	429 / 399	490 / 420	543 / 430	CFM/ton	CFM/ton	CFM/ton	CFM/ton	CFM/ton	CFM/ton	CFM/ton	CFM/ton	285	360	428	490	543		
	1770 / 1873	1784 / 1813	1789 / 1747	1788 / 1675	1782 / 1597	450	290	350	400	450	1770	1783	1788	1788	1782					
	386 / 443	468 / 481	543 / 512	612 / 534	671 / 546	CFM/ton	CFM/ton	CFM/ton	CFM/ton	CFM/ton	CFM/ton	CFM/ton	CFM/ton	385	467	543	611	671		
	1322 / 1431	1340 / 1358	1345 / 1274	1338 / 1179	1323 / 1069	290	350	400	450	290	350	400	450	1321	1338	1342	1336	1322		
	174 / 211	240 / 245	300 / 271	353 / 288	397 / 292	CFM/ton	CFM/ton	CFM/ton	CFM/ton	CFM/ton	CFM/ton	CFM/ton	CFM/ton	174	240	300	352	396		
	1646 / 1667	1660 / 1602	1665 / 1530	1662 / 1451	1653 / 1363	370	400	450	290	350	400	450	1564	1578	1582	1578	1569			
	315 / 320	392 / 357	463 / 386	527 / 407	582 / 417	CFM/ton	CFM/ton	CFM/ton	CFM/ton	CFM/ton	CFM/ton	CFM/ton	CFM/ton	274	348	416	476	529		
4.5 tons **†	1770 / 1873	1784 / 1813	1789 / 1747	1788 / 1675	1781 / 1597	400	450	290	350	400	450	1770	1783	1788	1788	1782				
	386 / 443	468 / 481	543 / 512	612 / 534	671 / 546	CFM/ton	CFM/ton	CFM/ton	CFM/ton	CFM/ton	CFM/ton	CFM/ton	CFM/ton	385	467	543	611	671		
	1989 / 2099	2004 / 2042	2012 / 1980	2013 / 1913	2009 / 1842	450	290	350	400	450	1989	2003	2011	2014	2011					
	535 / 612	627 / 650	712 / 681	788 / 703	855 / 716	CFM/ton	CFM/ton	CFM/ton	CFM/ton	CFM/ton	CFM/ton	CFM/ton	CFM/ton	534	626	711	788	856		
	1452 / 1557	1469 / 1489	1473 / 1413	1468 / 1327	1455 / 1231	290	350	400	450	290	350	400	450	1452	1467	1471	1466	1454		
	224 / 265	294 / 301	358 / 329	415 / 348	463 / 356	CFM/ton	CFM/ton	CFM/ton	CFM/ton	CFM/ton	CFM/ton	CFM/ton	CFM/ton	224	294	358	415	463		
	1817 / 1826	1831 / 1765	1837 / 1698	1837 / 1624	1831 / 1544	370	400	450	290	350	400	450	1723	1736	1741	1740	1734			
	415 / 451	499 / 451	576 / 481	647 / 503	708 / 515	CFM/ton	CFM/ton	CFM/ton	CFM/ton	CFM/ton	CFM/ton	CFM/ton	CFM/ton	357	437	511	578	636		
	1964 / 2073	1978 / 2015	1986 / 1953	1987 / 1886	1983 / 1814	400	450	290	350	400	1964	1978	1985	1988	1985					
	516 / 590	607 / 629	690 / 660	766 / 682	832 / 695	CFM/ton	CFM/ton	CFM/ton	CFM/ton	CFM/ton	CFM/ton	CFM/ton	CFM/ton	515	606	690	766	833		
5 tons	2231 / 2347	2245 / 2292	2252 / 2233	2252 / 2171	2185 / 2104	450	290	350	400	450	2232	2245	2252	2252	2186					
	741 / 842	842 / 879	934 / 908	1015 / 930	1024 / 941	CFM/ton	CFM/ton	CFM/ton	CFM/ton	CFM/ton	CFM/ton	CFM/ton	CFM/ton	741	842	934	1016	1023		
	<ul style="list-style-type: none"> † Factory Setting ** Not an actual OD size Status LED will blink once per 100 CFM requested. In torque mode, actual airflow may be lower. Torque mode will reduce airflow when static is above approximately 0.4" water column. 																			
	TAMXA0C60 MINIMUM HEATING AIRFLOW CFM — HEATER MATRIX																			
	MODEL NO.	BAYEAC04BK1	BAYEAC08BK1	BAYEAC10BK1	BAYEAC10LG3	BAYEABC15BK1	BAYEACB15LG3	BAYEABC20BK1	BAYEACC25BK1											
		BAYEAC04LG1	BAYEAC08LG1	BAYEAC10LG1	BAYEAC10LG3	BAYEABC15BK1	BAYEACB15LG3	BAYEABC20BK1	BAYEACC25BK1											
	TAMXA0C60	1063 / 1188	1063 / 1500	1125 / 1500	1000 / 1188	1125 / 1563	1250 / 1625	1500 / 1750	1625 / 1813											
	WITHOUT HEAT PUMP / WITH HP — SEE AIR HANDLER NAMEPLATE																			

Heater Attribute Data

Note: Heater size will be announced when using the resistor that is being provided with the BAYEA heater. Heater can also be configured in the UX360 User Interface or Diagnostics Mobile App.

TAMXA0A24V21DA											
Heater Model No.	No. of Circuits	240 Volt					208 Volt				
		Capacity		Heater Amps per Circuit	Minimum Circuit Ampacity	Maximum Overload Protection	Capacity		Heater Amps per Circuit	Minimum Circuit Ampacity	Maximum Overload Protection
		kW	BTUH				kW	BTUH			
No Heater	0	-	-	3.5 **	4	15	-	-	3.5 **	4	15
BAYEAAC04++1	1	3.84	13100	16.0	24	25	2.88	9800	13.8	22	25
BAYEAAC05++1	1	4.80	16400	20.0	29	30	3.60	12300	17.3	26	30
BAYEAAC08++1	1	7.68	26200	32.0	44	45	5.76	19700	27.7	39	40
BAYEAAC10++1 ^(a)	1	9.60	32800	40.0	54	60	7.20	24600	34.6	48	50
BAYEAAC10LG3	1-3 PH	9.60	32800	23.1	33	35	7.20	24600	20.0	29	30

Note: ** Motor Amps

^(a) Heater not qualified for 208V when installed in horizontal left position without Heat Pump

TAMXA0B30V31DA											
Heater Model No.	No. of Circuits	240 Volt					208 Volt				
		Capacity		Heater Amps per Circuit	Minimum Circuit Ampacity	Maximum Overload Protection	Capacity		Heater Amps per Circuit	Minimum Circuit Ampacity	Maximum Overload Protection
		kW	BTUH				kW	BTUH			
No Heater	0	-	-	3.5 **	4	15	-	-	3.5 **	4	15
BAYEAAC04++1	1	3.84	13100	16.0	24	25	2.88	9800	13.8	22	25
BAYEAAC05++1	1	4.80	16400	20.0	29	30	3.60	12300	17.3	26	30
BAYEAAC08++1	1	7.68	26200	32.0	44	45	5.76	19700	27.7	39	40
BAYEAAC10++1	1	9.60	32800	40.0	54	60	7.20	24600	34.6	48	50
BAYEAAC10LG3	1-3 PH	9.60	32800	23.1	33	35	7.20	24600	20.0	29	30
BAYEABC15LG3	1-3 PH	14.40	42000	34.6	47	50	10.80	36900	30.0	41	45
BAYEABC15BK1 - Circuit 1 ^(a)	2	9.60	32800	40.0	54	60	7.20	24600	34.6	48	50
BAYEABC15BK1 - Circuit 2		4.80	16400	20.0	25	25	3.60	12300	17.3	22	25

Note: ** Motor Amps

^(a) MCA and MOP for circuit 1 contains the motor amps

Heater Attribute Data

TAMXA0C36V31DA											
Heater Model No.	No. of Circuits	240 Volt					208 Volt				
		Capacity		Heater Amps per Circuit	Minimum Circuit Ampacity	Maximum Overload Protection	Capacity		Heater Amps per Circuit	Minimum Circuit Ampacity	Maximum Overload Protection
		kW	BTUH				kW	BTUH			
No Heater	0	-	-	3.5 **	4	15	-	-	3.5 **	4	15
BAYEAAC04++1	1	3.84	13100	16.0	24	25	2.88	9800	13.8	22	25
BAYEAAC05++1	1	4.80	16400	20.0	29	30	3.60	12300	17.3	26	30
BAYEAAC08++1	1	7.68	26200	32.0	44	45	5.76	19700	27.7	39	40
BAYEAAC10++1	1	9.60	32800	40.0	54	60	7.20	24600	34.6	48	50
BAYEAAC10LG3	1-3 PH	9.60	32800	23.1	33	35	7.20	24600	20.0	29	30
BAYEABC15LG3	1-3 PH	14.40	42000	34.6	47	50	10.80	36900	30.0	41	45
BAYEABC15BK1 - Circuit 1 ^(a)	2	9.60	32800	40.0	54	60	7.20	24600	34.6	48	50
BAYEABC15BK1 - Circuit 2		4.80	16400	20.0	25	25	3.60	12300	17.3	22	25
BAYEABC20BK1 - Circuit 1	2	9.60	32800	40.0	54	60	7.20	24600	34.6	48	50
BAYEABC20BK1 - Circuit 2		9.60	32800	40.0	50	50	7.20	24600	34.6	43	45

Note: ** Motor Amps

^(a) MCA and MOP for circuit 1 contains the motor amps

TAMXA0C42V41DA											
Heater Model No.	No. of Circuits	240 Volt					208 Volt				
		Capacity		Heater Amps per Circuit	Minimum Circuit Ampacity	Maximum Overload Protection	Capacity		Heater Amps per Circuit	Minimum Circuit Ampacity	Maximum Overload Protection
		kW	BTUH				kW	BTUH			
No Heater	0	-	-	3.5 **	4	15	-	-	3.5 **	4	15
BAYEAAC04++1	1	3.84	13100	16.0	24	25	2.88	9800	13.8	22	25
BAYEAAC05++1	1	4.80	16400	20.0	29	30	3.60	12300	17.3	26	30
BAYEAAC08++1	1	7.68	26200	32.0	44	45	5.76	19700	27.7	39	40
BAYEAAC10++1	1	9.60	32800	40.0	54	60	7.20	24600	34.6	48	50
BAYEAAC10LG3	1-3 PH	9.60	32800	23.1	33	35	7.20	24600	20.0	29	30
BAYEABC15LG3	1-3 PH	14.40	42000	34.6	47	50	10.80	36900	30.0	41	45
BAYEABC15BK1 - Circuit 1 ^(a)	2	9.60	32800	40.0	54	60	7.20	24600	34.6	48	50
BAYEABC15BK1 - Circuit 2		4.80	16400	20.0	25	25	3.60	12300	17.3	22	25
BAYEABC20BK1 - Circuit 1	2	9.60	32800	40.0	54	60	7.20	24600	34.6	48	50
BAYEABC20BK1 - Circuit 2		9.60	32800	40.0	50	50	7.20	24600	34.6	43	45

Note: ** Motor Amps

^(a) MCA and MOP for circuit 1 contains the motor amps

Heater Attribute Data

TAMXA0C48V41DA											
Heater Model No.	No. of Circuits	240 Volt					208 Volt				
		Capacity		Heater Amps per Circuit	Minimum Circuit Ampacity	Maximum Overload Protection	Capacity		Heater Amps per Circuit	Minimum Circuit Ampacity	Maximum Overload Protection
		kW	BTUH				kW	BTUH			
No Heater	0	-	-	5.0 **	6	15	-	-	5.0 **	6	15
BAYEAAC04++1	1	3.84	13100	16.0	26	30	2.88	9800	13.8	26	30
BAYEAAC05++1	1	4.80	16400	20.0	31	35	3.60	12300	17.3	28	30
BAYEAAC08++1	1	7.68	26200	32.0	46	50	5.76	19700	27.7	41	45
BAYEAAC10++1	1	9.60	32800	40.0	56	60	7.20	24600	34.6	50	50
BAYEAAC10LG3	1-3 PH	9.60	32800	23.1	34	35	7.20	24600	20.0	31	35
BAYEABC15LG3	1-3 PH	14.40	42000	34.6	49	50	10.80	36900	30.0	43	45
BAYEABC15BK1 - Circuit 1 (a) BAYEABC15BK1 - Circuit 2	2	9.60	32800	40.0	56	60	7.20	24600	34.6	50	50
		4.80	16400	20.0	25	25	3.60	12300	17.3	22	25
BAYEABC20BK1 - Circuit 1 BAYEABC20BK1 - Circuit 2	2	9.60	32800	40.0	56	60	7.20	24600	34.6	50	50
		9.60	32800	40.0	50	50	7.20	24600	34.6	43	45
BAYEACC25BK1 — Circuit 1 BAYEACC25BK1 — Circuit 2 BAYEACC25BK1 — Circuit 3	3	9.60	32800	40.0	56	60	7.20	24600	34.6	50	50
		9.60	32800	40.0	50	50	7.20	24600	34.6	43	45
		4.80	16400	20.0	25	25	3.60	12300	17.3	22	25

Note: ** Motor Amps

(a) MCA and MOP for circuit 1 contains the motor amps

TAMXA0C60V51DA											
Heater Model No.	No. of Circuits	240 Volt					208 Volt				
		Capacity		Heater Amps per Circuit	Minimum Circuit Ampacity	Maximum Overload Protection	Capacity		Heater Amps per Circuit	Minimum Circuit Ampacity	Maximum Overload Protection
		kW	BTUH				kW	BTUH			
No Heater	0	-	-	6.4 **	8	15	-	-	6.4 **	8	15
BAYEAAC04++1	1	3.84	13100	16.0	28	30	2.88	9800	13.8	25	25
BAYEAAC05++1	1	4.80	16400	20.0	33	35	3.60	12300	17.3	30	30
BAYEAAC08++1	1	7.68	26200	32.0	48	50	5.76	19700	27.7	43	45
BAYEAAC10++1	1	9.60	32800	40.0	58	60	7.20	24600	34.6	51	60
BAYEAAC10LG3	1-3 PH	9.60	32800	23.1	36	40	7.20	24600	20.0	32	35
BAYEABC15LG3	1-3 PH	14.40	42000	34.6	50	50	10.80	36900	30.0	45	45
BAYEABC15BK1 - Circuit 1 (a) BAYEABC15BK1 - Circuit 2	2	9.60	32800	40.0	58	60	7.20	24600	34.6	51	60
		4.80	16400	20.0	25	25	3.60	12300	17.3	22	25
BAYEABC20BK1 - Circuit 1 BAYEABC20BK1 - Circuit 2	2	9.60	32800	40.0	58	60	7.20	24600	34.6	51	60
		9.60	32800	40.0	50	50	7.20	24600	34.6	43	45
BAYEACC25BK1 (b) - Circuit 1 BAYEACC25BK1 - Circuit 2 BAYEACC25BK1 - Circuit 3	3	9.60	32800	40.0	57	60	7.20	24600	34.6	51	60
		9.60	32800	40.0	50	50	7.20	24600	34.6	43	45
		4.80	16400	20.0	25	25	3.60	12300	17.3	22	25

Note: ** Motor Amps

(a) MCA and MOP for circuit 1 contains the motor amps

(b) Heater not qualified for 208V when installed in horizontal left position without Heat Pump

Note: See Product Data or Air Handler nameplate for approved combinations of Air Handlers and Heaters.

Note: Heater model numbers may have additional suffix digits.

Distance from Belly Band to Shaft Face of Motor for Minimum Vibration

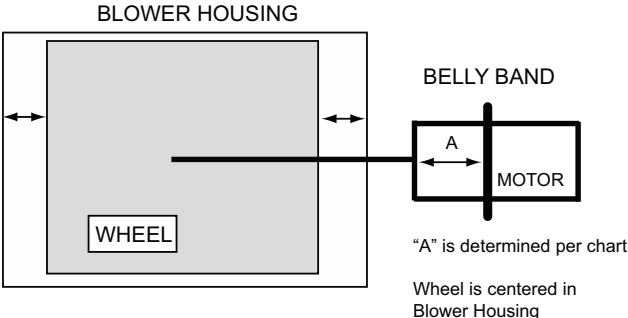

MODEL	DIM " A "
TAMXA0A24V21DA	2-3/8
TAMXA0B30V21DA	2-3/8
TAMXA0C36V31DA	2-3/8
TAMXA0C42V31DA	2-3/8
TAMXA0C48V41DA	2-3/8
TAMXA0C60V51DA	2-3/8

Air Handler Control Panel - LEDs

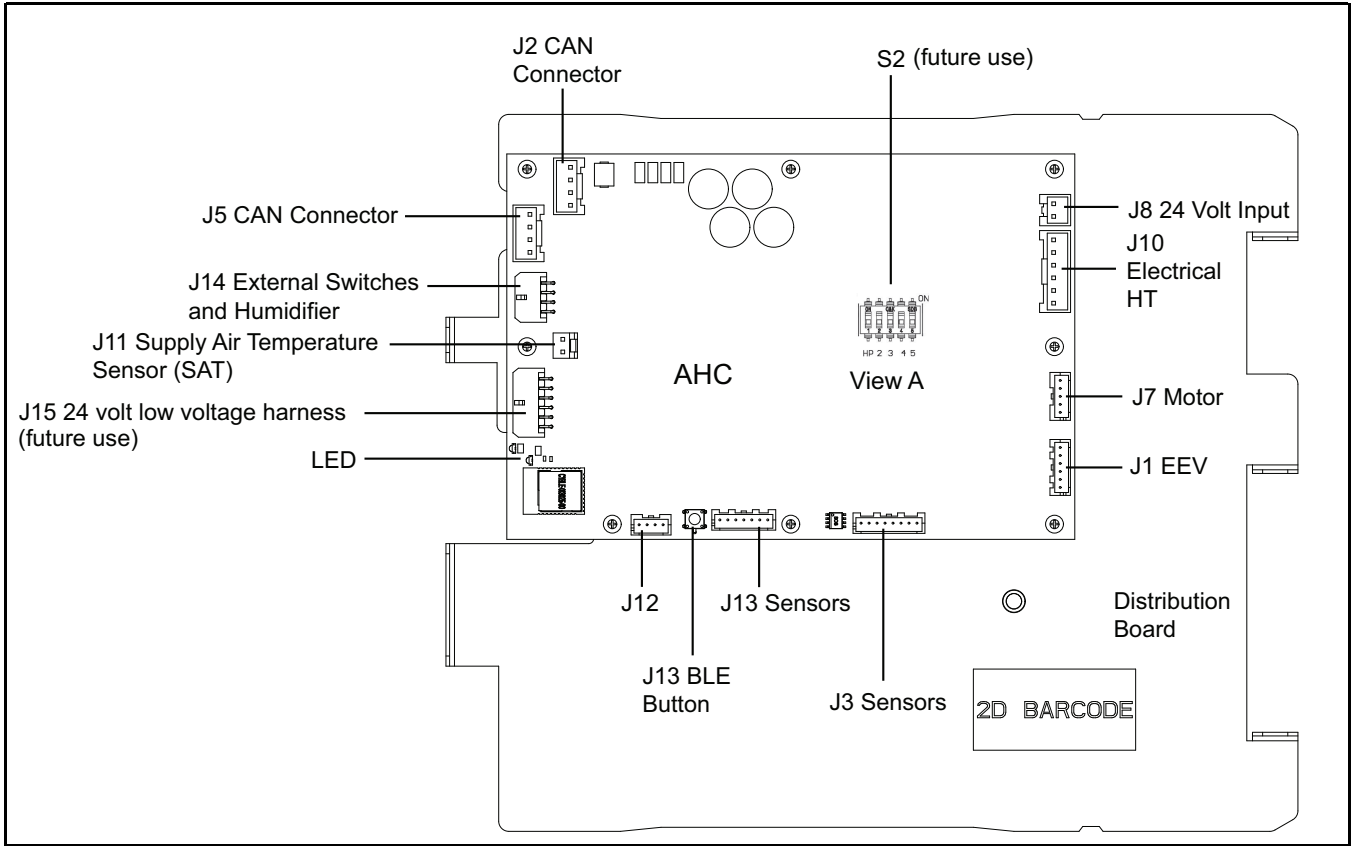

Table 1. TAMX LED Codes

FAULT LED (RED)	DESCRIPTION
Will announce the 4 most current faults at power up. Will announce current faults while fault is active.	Normal operation
AHC COMM LED (AMBER)	DESCRIPTION
Device Count	Number of communicating devices ^(a)

^(a) Examples: communicating thermostat, communicating air cleaner, etc.

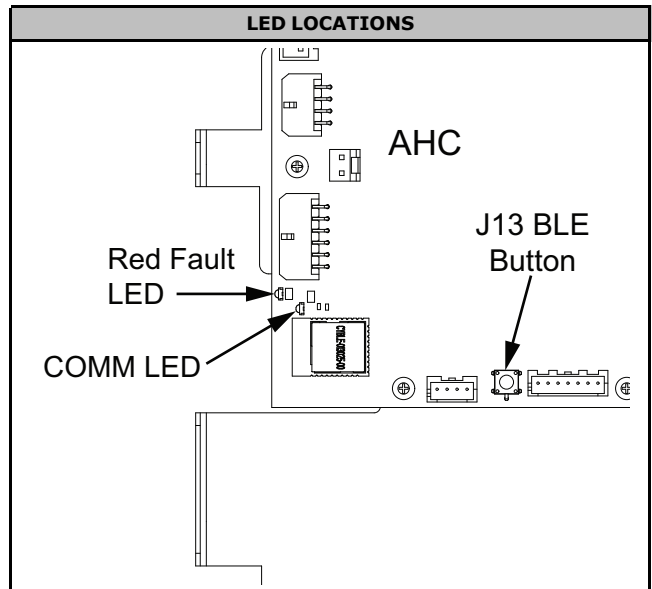
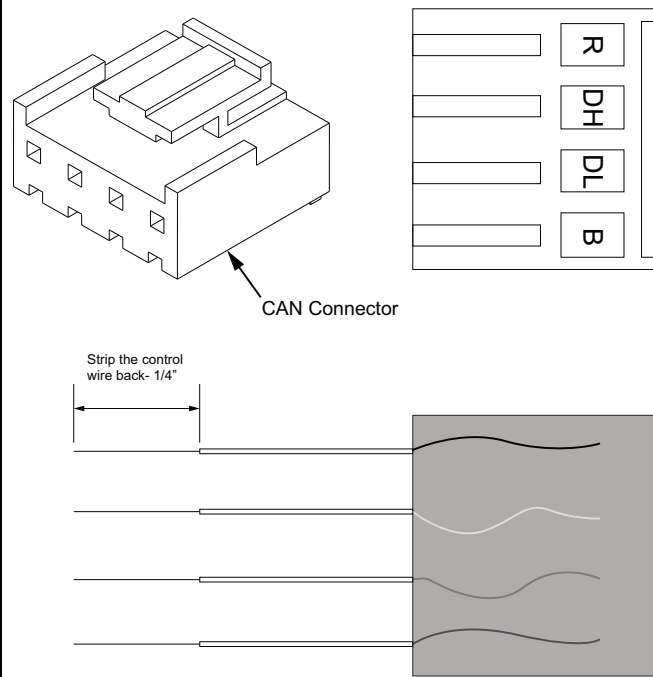

Table 2. Low Voltage Maximum Wire Length

<p>The Low Voltage Maximum Wire Length table defines the size and combined total maximum length of the low voltage wiring from the outdoor unit, to the indoor unit, and to the thermostat.</p> <p>Note: <i>The use of color coded low voltage wire is recommended to simplify connections between the outdoor unit, the control, and the indoor unit.</i></p>	Control Wire – Communicating	
	WIRE SIZE	MAX. WIRE LENGTH
	18 AWG	500 FT. Combined
	Control Wire – 24 Volt	
	WIRE SIZE	MAX. WIRE LENGTH
	18 AWG	100 FT. Combined

Table 3. Link Communicating Low Voltage Wire Connectors

<p>Link mode uses simple connectors for low voltage connections. These connections are color coded which makes the installation easier and quicker.</p> <table border="1" style="margin: 10px auto;"> <thead> <tr> <th colspan="2">Wire Colors</th> </tr> </thead> <tbody> <tr> <td>R</td> <td>Red</td> </tr> <tr> <td>DH</td> <td>White</td> </tr> <tr> <td>DL</td> <td>Green</td> </tr> <tr> <td>B</td> <td>Blue</td> </tr> </tbody> </table> <p>Do the following to make the connections from the actual thermostat wire to the connector.</p> <p>Note: <i>These connectors are necessary at the communicating outdoor unit, communicating indoor unit, distribution board(s), system controller and communicating accessories.</i></p> <ol style="list-style-type: none"> Strip the Red, White, Green and Blue thermostat wires back 1/4". Insert the wires into the connector in the correctly colored locations. When you feel it release, allow each wire to slide in further. Pull back on the wires individually and slightly and check if the wires are seated properly. If each wire does not pull out for all four wires, the connection is complete. Connectors are ONE TIME USE. If a 18 ga. Thermostat wire gets broken off inside of the connector, the connector will need replaced. Wire colors are for illustration purposes only. If using a different color, ensure it lands at the correct terminal throughout all of the communicating control wiring. <p>Connect the CAN connector into the male coupling on the low voltage harness at the Outdoor unit.</p> <p>This air handler has two dedicated CAN Connector headers on the Air Handler Control (AHC) board. In Link communicating mode, both of them are in the communicating loop. It does not matter which one goes to the thermostat, System Controller, distribution board, outdoor unit or any other Link accessory.</p>	Wire Colors		R	Red	DH	White	DL	Green	B	Blue	 <p style="text-align: center;">CAN Connector</p> <p style="text-align: center;">Strip the control wire back- 1/4"</p> <p>Note: <i>For use with 18 ga. solid core thermostat wire.</i></p>
Wire Colors											
R	Red										
DH	White										
DL	Green										
B	Blue										

Air Handler Control Panel - LEDs

Table 4. Link Communicating Low Voltage Wire Hook-up Diagrams

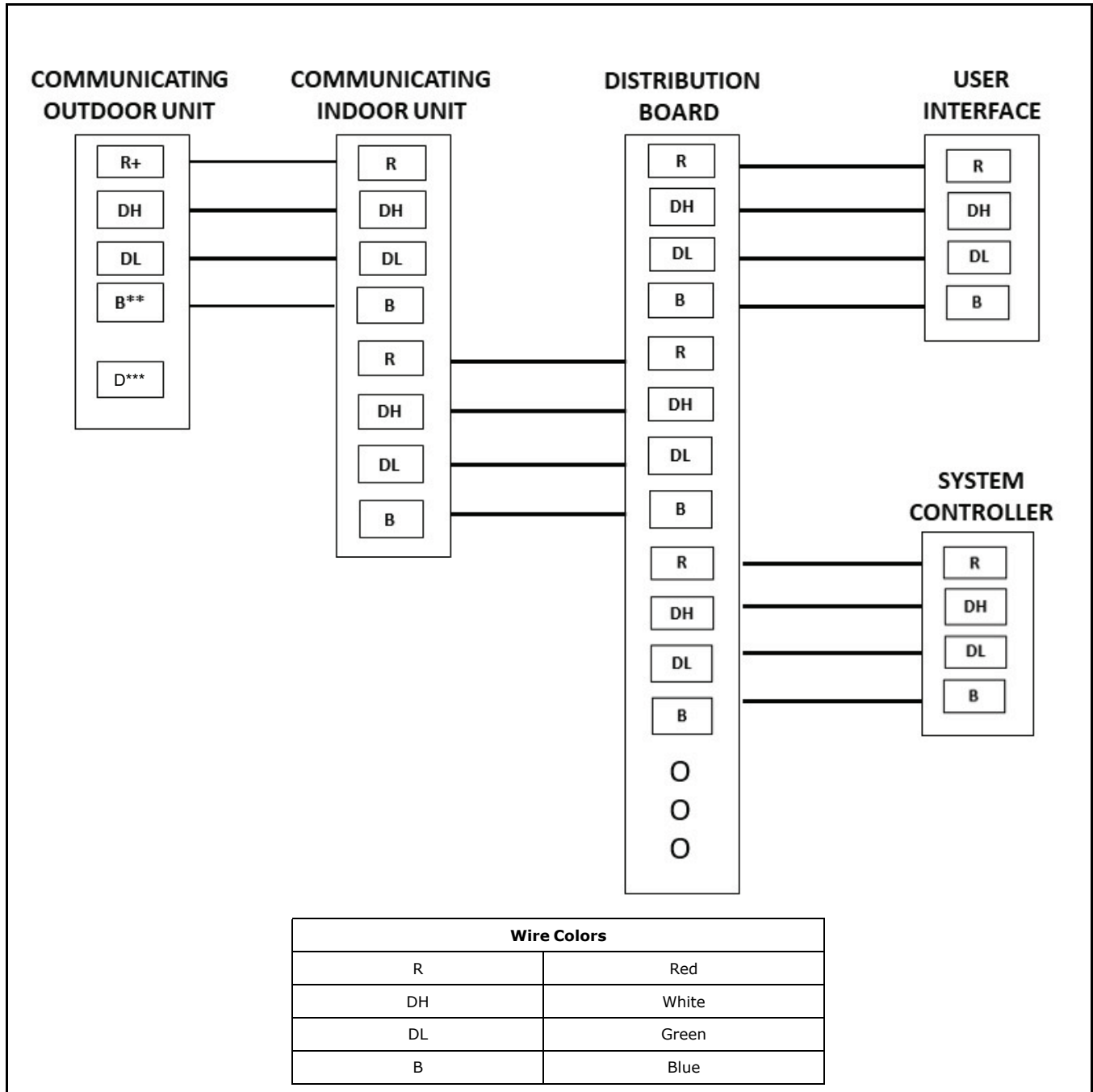

Note:

- * —HUM and EAC terminals are dry contact outputs only.
- + —R connection to the outdoor unit is required only in applications utilizing an outdoor loadshed device or when using a 24 VAC charging solenoid during automatic weigh-in charging.
- ** —B connection to the outdoor unit is optional for 2 wire outdoor applications, but is recommended in other applications.

Sensor Locations

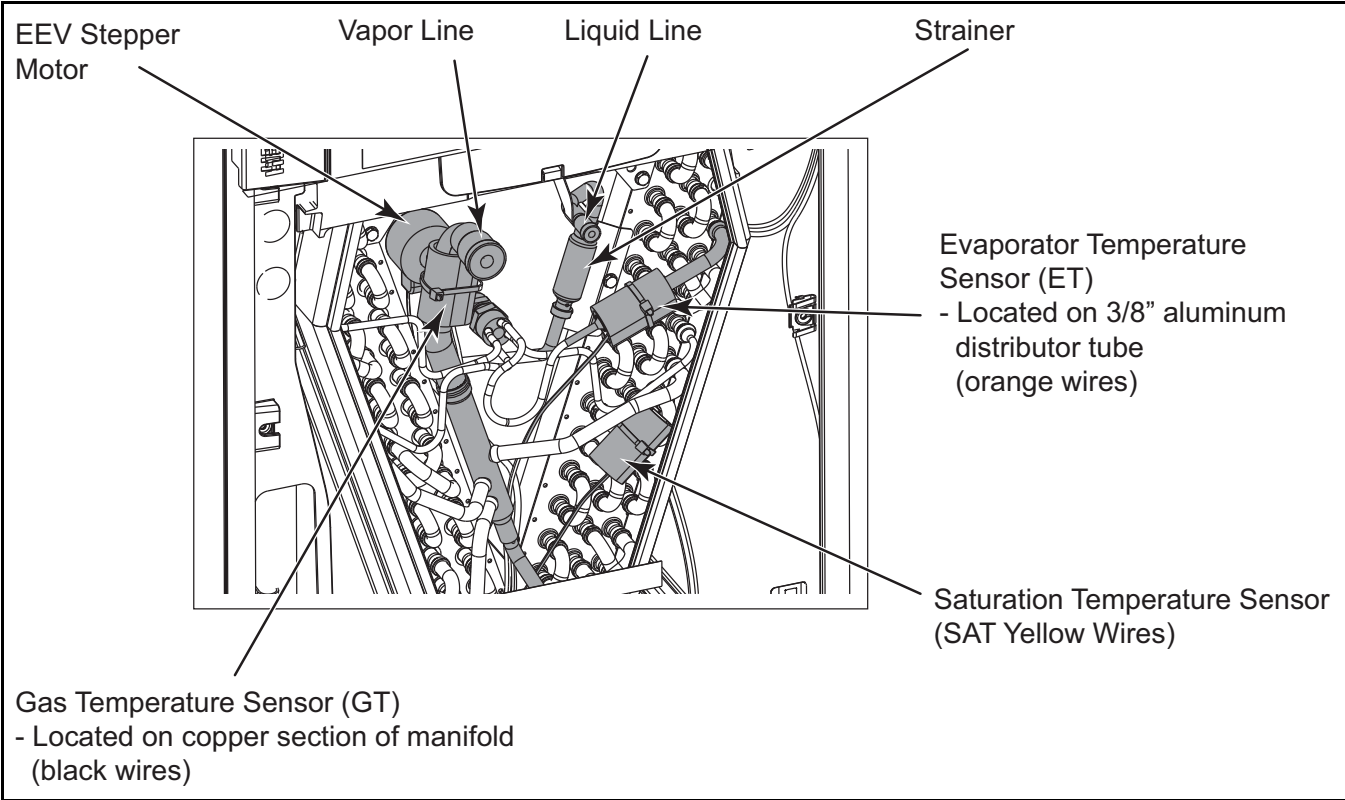

Stepper Motor Tables

— For use with Low and High Superheat Troubleshooting

Table 1 — For use with FIG 1		
Common Terminal	to Terminal	Measurement
Gray	Orange	46 ohms
Gray	Red	46 ohms
Gray	Yellow	46 ohms
Gray	Black	46 ohms

Table 2— For use with FIG 2		
Common Terminal	to Terminal	Measurement
Brown	Blue	46 ohms
Brown	Yellow	46 ohms
Red	Orange	46 ohms
Red	White	46 ohms

FIG 1

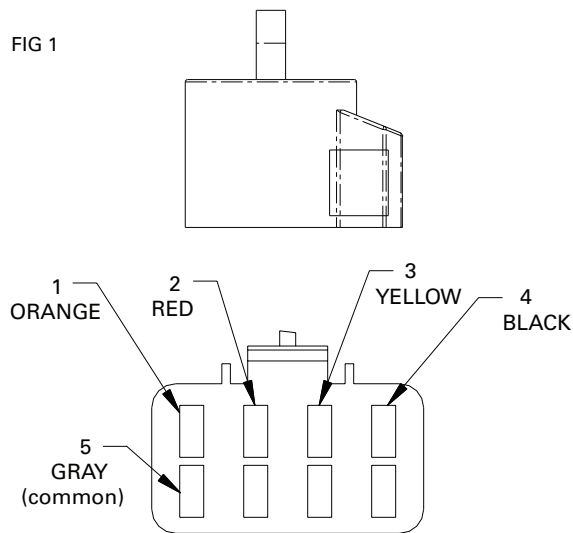
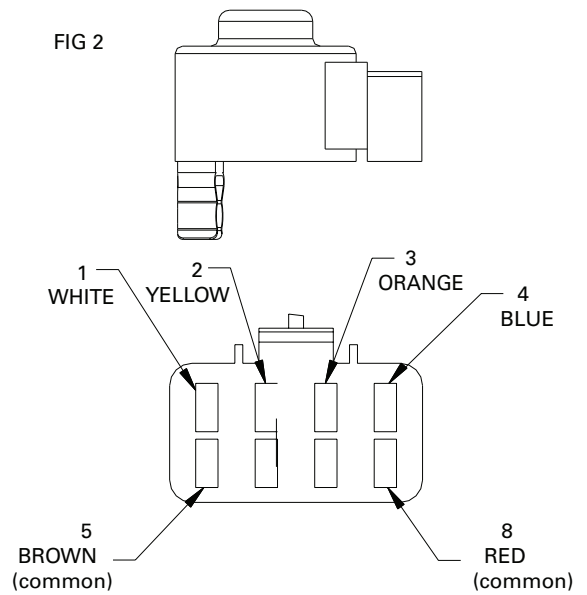
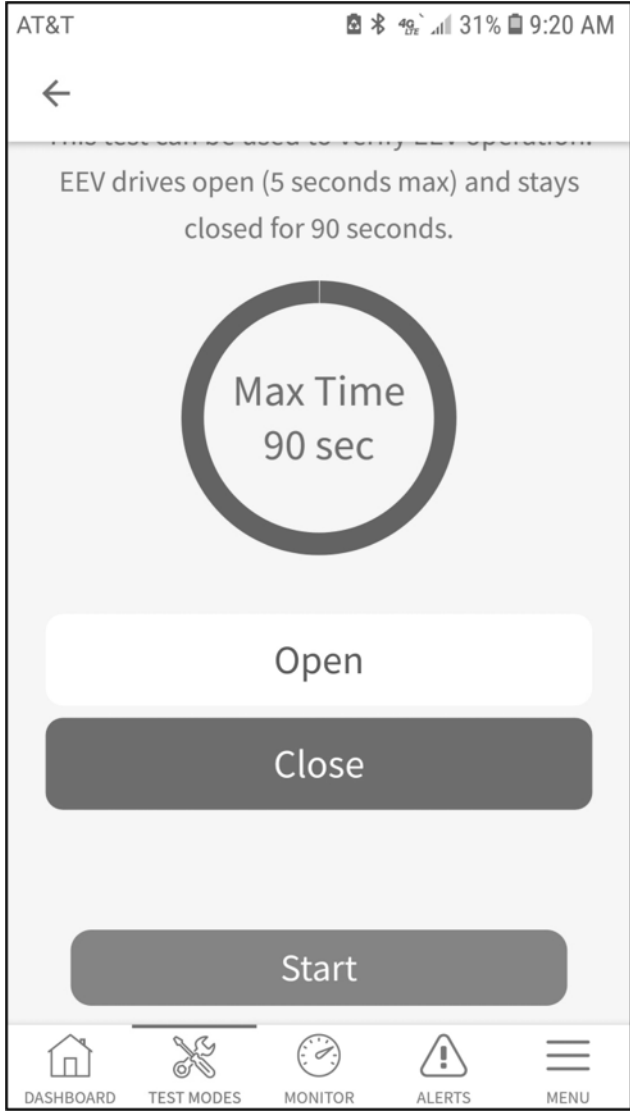

FIG 2



EEV Test Options

EEV test options are only available through the Diagnostics Mobile App. While in the Diagnostics Mobile App, choose Test Modes. You will have an option to test the Indoor EEV Open or Closed. The Open test will open the indoor EEV completely for 30 seconds. At the end of the Open test, the control will either revert back to normal operation or will close if in the OFF cycle. The Closed test will close the indoor EEV completely for 90 seconds. At the end of the Closed test, the control will revert back to normal operation or stay closed if in the off mode. If the unit is running in the cooling mode while performing a Closed test, the units suction pressure will drop and likely trip off on Low Pressure Cut Out.



EVC Thermal Resistance and Voltage Table

TEMP F	TEMP C	THERMISTOR RESISTANCE (OHMS) *	Volts DC at plug J3 EVAP TEMP (ET) Orange to Orange GAS TEMP (GT) Black to Black	TEMP F	TEMP C	THERMISTOR RESISTANCE (OHMS) *	Volts DC at plug J3 EVAP TEMP (ET) Orange to Orange GAS TEMP (GT) Black to Black	TEMP F	TEMP C	THERMISTOR RESISTANCE (OHMS) *	Volts DC at plug J3 EVAP TEMP (ET) Orange to Orange GAS TEMP (GT) Black to Black
20	- 6.7	45076	3.20	51	10.6	18896	2.16	94	34.4	6516	1.04
21	- 6.1	43764	3.17	52	11.1	18401	2.12	96	35.6	6224	1.01
22	- 5.6	42494	3.14	53	11.7	17921	2.09	98	36.7	5946	0.97
23	- 5.0	41266	3.10	54	12.2	17455	2.06	100	37.8	5682	0.93
24	- 4.4	40077	3.07	55	12.8	17002	2.03	102	38.9	5432	0.90
25	- 3.9	38927	3.04	56	13.3	16563	2.00	104	40.0	5194	0.87
26	- 3.3	37813	3.00	57	13.9	16137	1.97	106	41.1	4968	0.84
27	- 2.8	36736	2.97	58	14.4	15723	1.94	108	42.2	4753	0.81
28	- 2.2	35692	2.93	59	15.0	15320	1.91	110	43.3	4548	0.78
29	- 1.7	34681	2.90	60	15.6	14930	1.88	112	44.4	4354	0.75
30	- 1.1	33703	2.86	61	16.1	14550	1.85	114	45.6	4169	0.72
31	- 0.6	32755	2.83	62	16.7	14182	1.82	116	46.7	3992	0.70
32	0.0	31838	2.80	63	17.2	13824	1.79	118	47.8	3825	0.67
33	0.6	30949	2.76	64	17.8	13476	1.76	120	48.9	3665	0.65
34	1.1	30087	2.73	65	18.3	13138	1.73	122	50.0	3513	0.62
35	1.7	29253	2.69	66	18.9	12810	1.70	124	51.1	3368	0.60
36	2.2	28445	2.66	67	19.4	12491	1.67	126	52.2	3230	0.58
37	2.8	27661	2.62	68	20.0	12181	1.65	128	53.3	3098	0.56
38	3.3	26902	2.59	69	20.6	11879	1.62	130	54.4	2972	0.54
39	3.9	26166	2.56	70	21.1	11586	1.59	132	55.6	2853	0.52
40	4.4	25452	2.52	72	22.2	11024	1.54	134	56.7	2738	0.50
41	5.0	24761	2.49	74	23.3	10492	1.49	136	57.8	2629	0.48
42	5.6	24090	2.45	76	24.4	9990	1.44	138	58.9	2525	0.46
43	6.1	23440	2.42	78	25.6	9515	1.39	140	60.0	2425	0.45
44	6.7	22810	2.39	80	26.7	9065	1.34	142	61.1	2330	0.43
45	7.2	22198	2.35	82	27.8	8639	1.29	144	62.2	2239	0.42
46	7.8	21605	2.32	84	28.9	8236	1.25	146	63.3	2153	0.40
47	8.3	21030	2.29	86	30.0	7855	1.20	148	64.4	2070	0.39
48	8.9	20472	2.25	88	31.1	7493	1.16	150	65.6	1990	0.37
49	9.4	19931	2.22	90	32.2	7150	1.12	Values should be within +/- 5%			
50	10.0	19405	2.19	92	33.3	6825	1.08				

Test Methods	
<ol style="list-style-type: none"> When measuring DC voltage, use Evap Temp and Gas Temp points to GND (ground) test point. When measuring DC voltage, measure from ET Sensor pin to pin and GT Sensor pin to pin at J3 connector. When measuring resistance, remove J3 harness and measure ET and GT pin to pin 	

Troubleshooting

Sensor Check

Perform these steps to verify sensor placement and operation

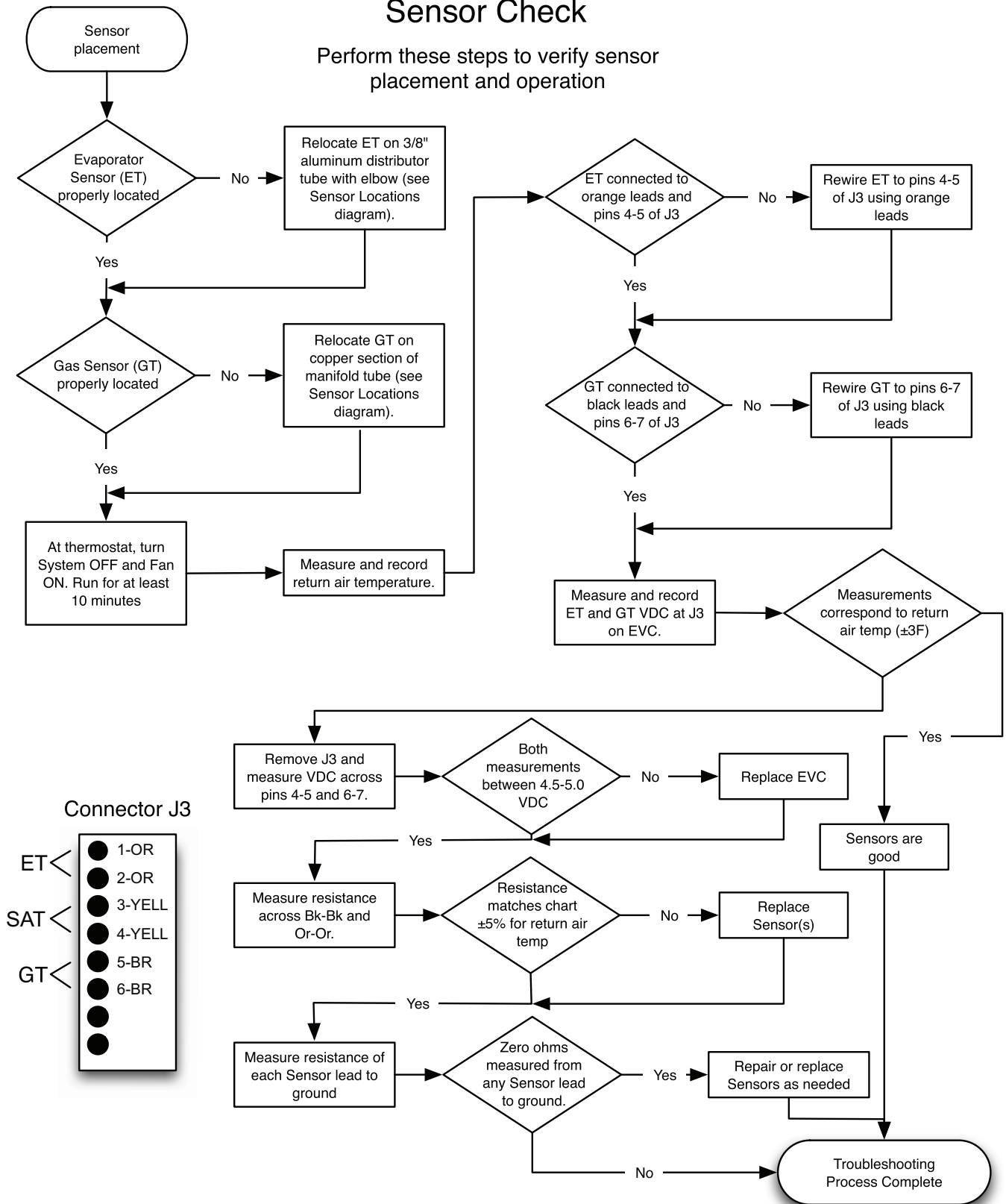

Troubleshooting

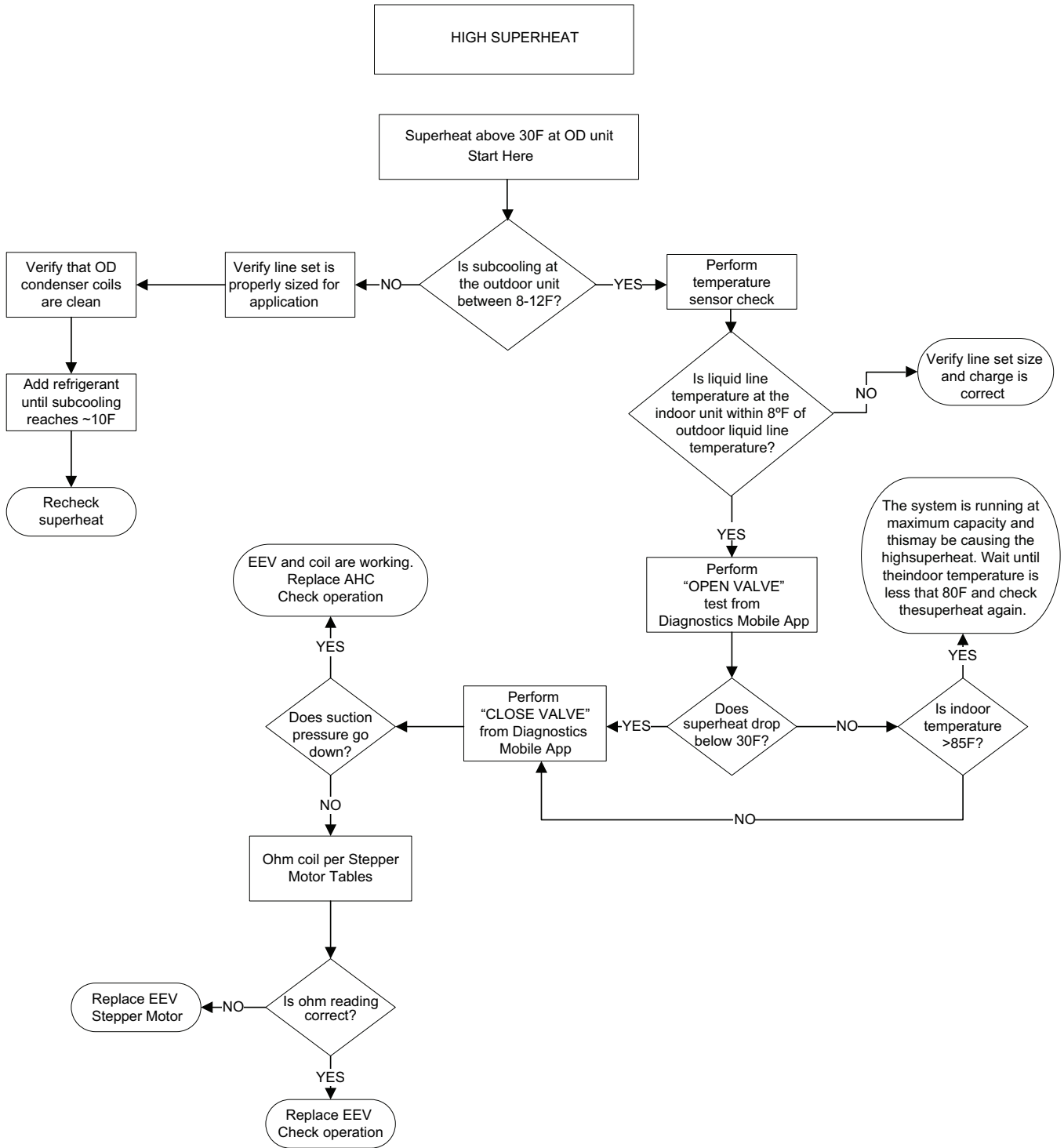

Troubleshooting Low Superheat

Perform these steps if Superheat is less than 3°F

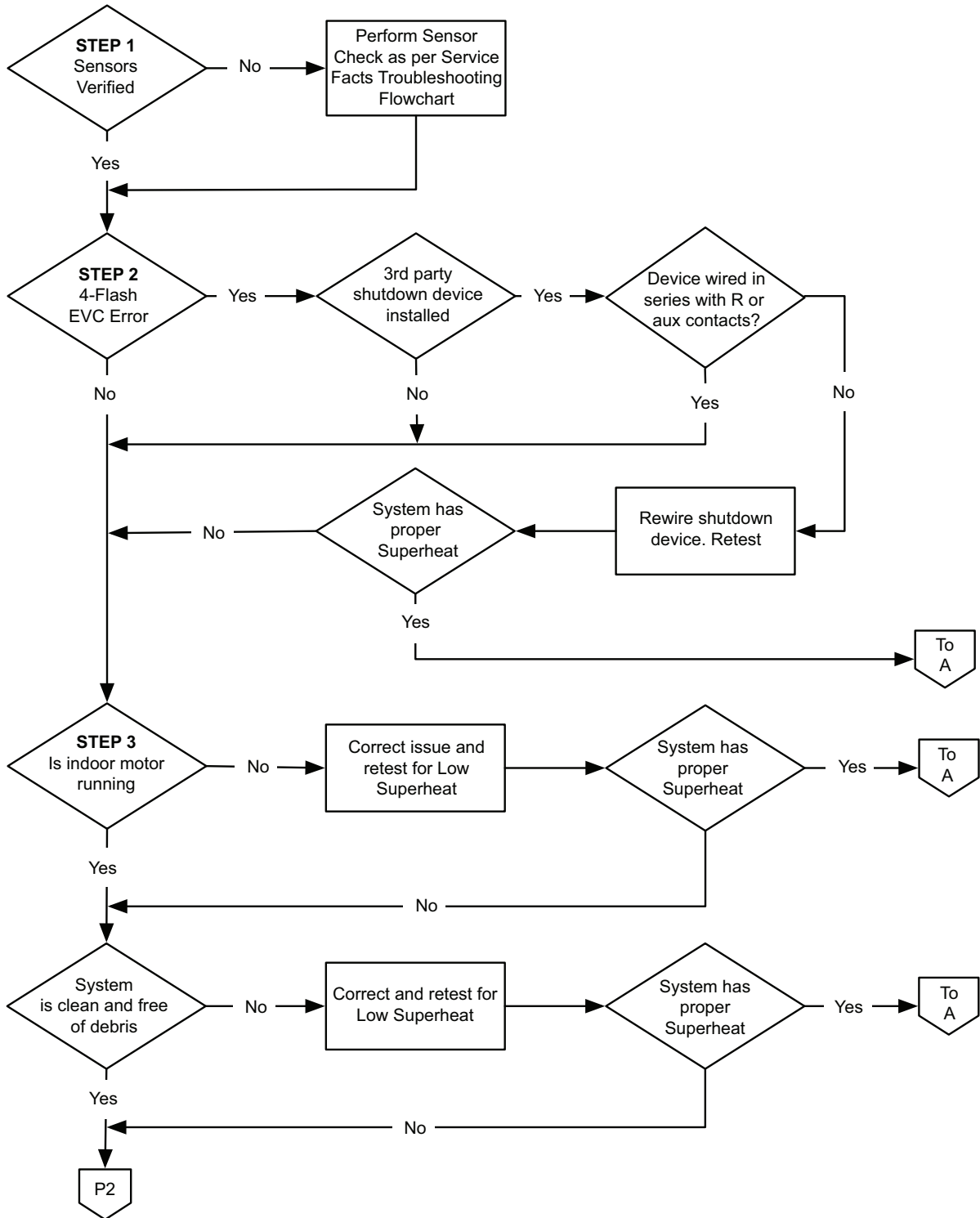

Troubleshooting Low Superheat - page 2

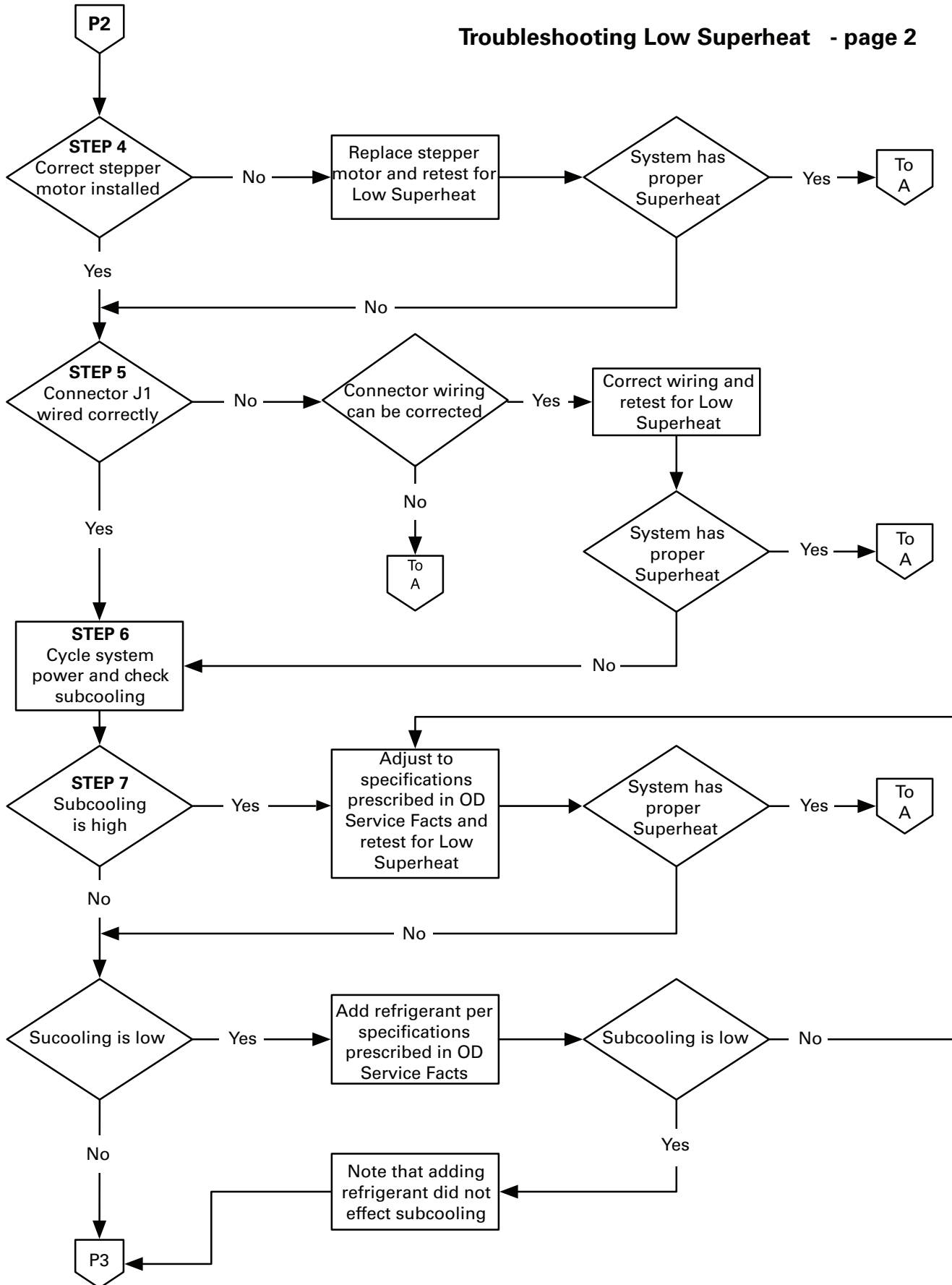

Troubleshooting Low Superheat - page 3

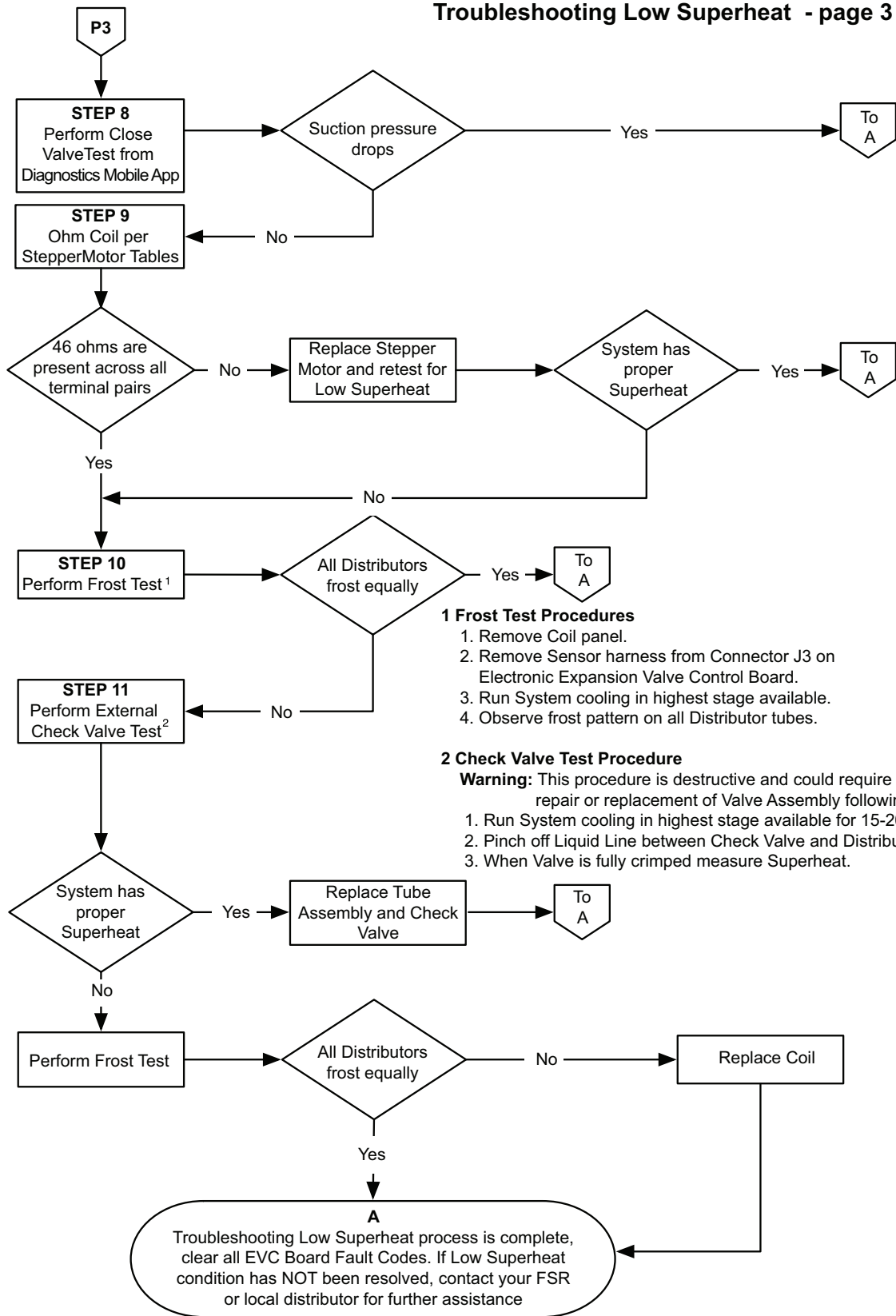

1 Frost Test Procedures

1. Remove Coil panel.
2. Remove Sensor harness from Connector J3 on Electronic Expansion Valve Control Board.
3. Run System cooling in highest stage available.
4. Observe frost pattern on all Distributor tubes.

2 Check Valve Test Procedure

Warning: This procedure is destructive and could require repair or replacement of Valve Assembly following test.

1. Run System cooling in highest stage available for 15-20 minutes.
2. Pinch off Liquid Line between Check Valve and Distributor Assembly.
3. When Valve is fully crimped measure Superheat.

About Trane and American Standard Heating and Air Conditioning

Trane and American Standard create comfortable, energy efficient indoor environments for residential applications. For more information, please visit www.trane.com or www.americanstandardair.com.



The manufacturer has a policy of continuous data improvement and it reserves the right to change design and specifications without notice. We are committed to using environmentally conscious print practices.