



**TRANE®**

# Upflow/Horizontal 2-Stage, Communicating Variable Speed Gas Furnace

---

## XC80

TUD2B060ACV32B  
TUD2B080ACV32B  
TUD2C080ACV42B  
TUD2B100ACV32B  
TUD2C100ACV52B  
TUD2D120ACV52B  
TUD2D140ACV52B

TDD2B060ACV32B  
TDD2B080ACV32B  
TDD2C100ACV52B  
TDD2D120ACV52B

## Two-Stage Fan Assisted Combustion System

TUD2-ACV  
Upflow/Horizontal

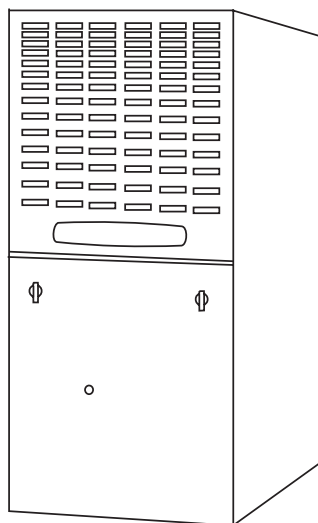

TDD2-ACV  
Downflow/Horizontal

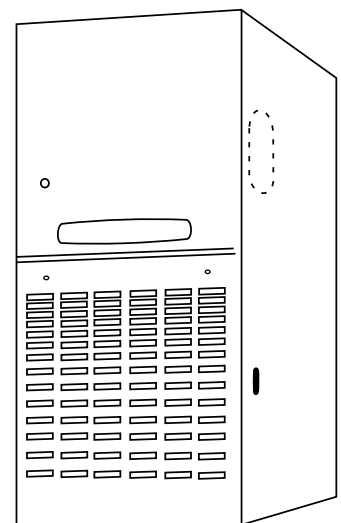

---

**PUB. NO. 22-1827-08**



# General Features

---

## COMMUNICATING MODE

Furnace is shipped ready to be connected in communicating mode using three wire hook-up using TCONT900 comfort control.

## ALTERNATE 24V MODE

Furnace is field configurable to 24V non-communicating mode.

## COMFORT CONTROL

Comfortlink II™ Communicating furnace design, offers plug and play – walk away installation. Assures the entire heating and air conditioning system is set up in the proper modes to optimize the engineered performance of the matched system installed.

## NATURAL GAS MODELS

Central Heating furnace designs are certified by the American Gas Association for both natural and L.P. gas. Limit setting and rating data were established and approved under standard rating conditions using American National Standards Institute standards.

## SAFE OPERATION

The Integrated System Control has solid state devices, which continuously monitor for presence of flame, when the system is in the heating mode of operation. Dual solenoid combination gas valve and regulator provide extra safety.

## QUICK HEATING

Durable, cycle tested, heavy gauge **aluminized steel heat exchanger** quickly transfers heat to provide warm conditioned air to the structure. **Low energy power vent blower**, to increase efficiency and provide a positive discharge of gas fumes to the outside.

## BURNERS

Multiport In-shot burners will give years of quiet and efficient service. All models can be converted to **L.P. gas**.

## INTEGRATED SYSTEM CONTROL

Exclusively designed operational program provides total control of furnace limit sensors, blowers, gas valve, flame control and includes self diagnostics for ease of service. Also includes connection points for E.A.C./humidifier.

## AIR DELIVERY

The variable speed, direct drive blower motor, has sufficient airflow for most heating and cooling requirements, will switch from heating to cooling speeds on demand from room thermostat. The blower door safety switch will prevent or terminate furnace operation when the blower door is removed.

## STYLING

**Heavy gauge steel and “wrap-around” cabinet construction** is used in the cabinet with baked-on enamel finish for strength and beauty. The heat exchanger section of the cabinet is completely lined with foil faced fiberglass insulation. This results in quiet and efficient operation due to the excellent acoustical and insulating qualities of fiberglass. Built-in bottom pan and alternate bottom, left or right side return air connection provision.

## FEATURES AND GENERAL OPERATION

The XC 80 High Efficiency Gas Furnaces employ a Hot Surface Ignition system, which eliminates the waste of a constant burning pilot. The integrated system control lights the main burners upon a demand for heat from the room thermostat. Complete front service access.

- a. Low energy power venter
- b. Vent proving pressure switch.



# Contents

---

Feature Summary	2
Features and Benefits	4
Standard Equipment	
Optional Equipment	
General Data	6
TUD2B060ACV32B	
TUD2B080ACV32B	
TUD2C080ACV42B	
TUD2B100ACV32B	
TUD2C100ACV52B	
TUD2D120ACV52B	
TUD2D140ACV52B	
TDD2B060ACV32B	
TDD2B080ACV32B	
TDD2C100ACV52B	
TDD2D120ACV52B	
Performance Data	9
Electric Data	20
Field Wiring Diagrams	24
Dimensions	29



# Features and Benefits

---

## XC 80 STANDARD EQUIPMENT

- **ComfortLink™ II** Communication or 24 Volt control
  - Factory default is communication mode
  - Field configurable to 24 volt non-communicating mode
  - Communication mode may be used with:
    - All communicating outdoor units
    - 24V Single stage cooling only units
  - 24 Volt non-communication mode may be used with:
    - 24V Single stage, two stage, or two speed outdoor units
  - Plug and play installation in communication mode with communicating Comfort Control
  - Three wire connections to Comfort Control when used with communicating Comfort Control (TCONT900AC43UA)
  - Two speed inducer motor
  - Stored fault code history in microprocessor non-volatile memory
  - Furnace certified to leak 2% or less of nominal air conditioning CFM delivered when pressurized to .5" water column with all inlets, outlets, and drains sealed.
  - Slide out blower assembly
  - Variable speed ECM blower motor with continuous **Comfort-R™**
  - Silicon Nitride hot surface igniter with adaptive heat up
  - Manual reset flame rollout switches
  - Power supply 115/1/60
  - Upflow models are convertible to Horizontal Left or Left airflow.
  - Downflow models are convertible to Horizontal Right or Left airflow.\*
  - 115 Volt EAC/Humidifier connections
  - 2-stage modulating gas valve
  - Accessory hook-up capability
  - Integrated solid state control with self-diagnostics
  - Improved **CleanEffects™** connections
  - Attractive color accents
  - Heavy gauge aluminized steel heat exchanger
  - Multi-port In-shot burners
  - Insulated blower door
  - Gasketed blower door
  - Complete front service access
  - Left/right gas connection
  - Optional L.P conversion kit
  - **Optional extended warranties**
- \* See Installer's Guide for venting applications.



# Features and Benefits

## XC80 OPTIONAL EQUIPMENT

Comfort control, Electronic Programmable 4-Stage Heating/ 2-Stage Cooling <sup>①</sup> .....	TCONT900AC43UA [ ]
Comfort Control, XL802, Programmable 7 Day, 3-Ht, 2-Cl .....	TCONT802AS32DA [ ]
Comfort Control, XL803, Programmable 7 Day, 3-Ht, 2-Cl with dehumidification.....	TCONT803AS32DA [ ]
Harness kit for 24V non-communicating connection .....	BAYACHP024* [ ]
Propane Conversion Kit.....	BAYLPKT210B [ ]
Propane Conversion Kit (with Stainless Steel Burners) .....	BAYLPSS210B [ ]
5" Expandable High Efficiency Media Filter (17-1/2" Wide Gas Furnace) .....	TFM175B0FR0 [ ]
5" Expandable High Efficiency Media Filter (21" Wide Gas Furnace).....	TFM210B0FR0 [ ]
5" Expandable High Efficiency Media Filter (24-1/2" Wide Gas Furnace) .....	TFM245B0FR0 [ ]
5" Cartridge High Efficiency Media Filter (17-1/2" Wide Gas Furnace) .....	TFM175A0FR1 [ ]
5" Cartridge High Efficiency Media Filter (21" Wide Gas Furnace).....	TFM210A0FR1 [ ]
5" Cartridge High Efficiency Media Filter (24-1/2" Wide Gas Furnace) .....	TFM245A0FR1 [ ]
1" Medium Efficiency Pleated Filter (17 - 1/2" Wide Gas Furnace).....	TFP175A0FR1 [ ]
1" Medium Efficiency Pleated Filter (21" Wide Gas Furnace).....	TFP210A0FR1 [ ]
1" Medium Efficiency Pleated Filter (24-1/2" Wide Gas Furnace).....	TFP245A0FR1 [ ]
Coil Enclosure (17-1/2" Wide Cabinets).....	BAYCLE17A1722A [ ]
Coil Enclosure (21" Wide Cabinets).....	BAYCLE21A2130A [ ]
Coil Enclosure (24-1/2" Wide Cabinets) .....	BAYCLE24A2430A [ ]
High Altitude Switch.....	BAYHALT249 [ ]
Masonry Chimney Vent Kit (Upflow models only).....	BAYVENT800B [ ]
Filter Rack Kit <sup>②</sup> .....	BAYRACK960A [ ]
Cleanable Filter (14.5"/17.5" wide Upflow models).....	BAYFLTR317 [ ]
Cleanable Filter (21" wide Upflow models) .....	BAYFLTR321 [ ]
Cleanable Filter (24.5" wide Upflow models) .....	BAYFLTR324 [ ]
CleanEffects™, Whole House Air Cleaner (Upflow 17-1/2" Wide Gas Furnace) .....	TFD175CLFR000C [ ]
CleanEffects™, Whole House Air Cleaner (Upflow 21" Wide Gas Furnace) .....	TFD210CLFR000C [ ]
CleanEffects™, Whole House Air Cleaner (Upflow 24-1/2" Wide Gas Furnace) .....	TFD245CLFR000C [ ]
CleanEffects™, Whole House Air Cleaner (Downflow 17-1/2" Wide Gas Furnace) .....	TFD17DCLFR000C [ ]
CleanEffects™, Whole House Air Cleaner (Downflow 21" Wide Gas Furnace) .....	TFD21DCLFR000C [ ]
CleanEffects™, Whole House Air Cleaner (Downflow 24-1/2" Wide Gas Furnace) .....	TFD24DCLFR000C [ ]
CleanEffects™, Whole House Transformer Kit (120 to 24 Volt - all TFD Air Cleaners).....	BAYTRANS12024 [ ]
CleanEffects™ Connection Kit for Communicating Furnace (24 volt converted units only) .....	BAYACCECOMM101 [ ]

① TCONT900AC43UA must be used for communication.

② Available for models with 1800 CFM or greater which require an additional side return.



# General Data

## Product Specifications <sup>①</sup>

MODEL	*UD2B060ACV32B	*UD2B080ACV32B	*UD2C080ACV42B
TYPE	Upflow/Horizontal	Upflow/Horizontal	Upflow/Horizontal
<b>RATINGS</b> <sup>②</sup>			
1st Stage Input BTUH	39,000	52,000	52,000
1st Stage Capacity BTUH (ICS) <sup>③</sup>	31,200	41,600	41,600
2nd Stage Input BTUH	60,000	80,000	80,000
2nd Stage Capacity BTUH (ICS) <sup>③</sup>	48,000	64,000	64,000
Temp. rise (Min.-Max.) °F.	30 - 60	30 - 60	30 - 60
<b>BLOWER DRIVE</b> <sup>③⑥⑦</sup>			
	Direct	Direct	Direct
Diameter - Width (In.)	10 x 7	10 x 7	10 x 10
No. Used	1	1	1
Speeds (No.)	Variable	Variable	Variable
CFM vs. in. w.g.	See Airflow Table	See Airflow Table	See Airflow Table
Motor HP	1/2	1/2	3/4
R.P.M.	Variable	Variable	Variable
Volts/Ph/Hz	115/1/60	115/1/60	115/1/60
FLA	5.2	5.2	7.4
<b>COMBUSTION FAN — Type</b>			
	Centrifugal	Centrifugal	Centrifugal
Drive - No. Speeds	Direct - 2	Direct - 2	Direct - 2
Motor HP PSC [Shaded Pole] - RPM	1/100 / [1/145] - 2543/1727	1/100 / [1/145] - 2543/1727	1/100 / [1/145] - 2543/1727
Volts/Ph/Hz	115/1/60	115/1/60	115/1/60
FLA PSC [Shaded pole]	0.70/0.40 / [0.23/0.20]	0.70/0.40 / [0.23/0.20]	0.70/0.40 / [0.23/0.20]
<b>FILTER — Furnished?</b>			
	Yes	Yes	Yes
Type Recommended	High Velocity	High Velocity	High Velocity
Hi Vel. (No.-Size-Thk.)	1 - 17x25 - 1in.	1 - 17x25 - 1in.	1 - 20x25 - 1in.
<b>VENT — Size (In.)</b>			
	4 Round	4 Round	4 Round
<b>HEAT EXCHANGER</b>			
Type -Fired	Alum. Steel - Type 1	Alum. Steel - Type 1	Alum. Steel - Type 1
-Unfired			
Gauge (Fired)	20	20	20
<b>ORIFICES — Main</b> <sup>⑤</sup>			
Nat. Gas Qty. — Drill Size	3 — 45	4 — 45	4 — 45
L.P. Gas Qty. — Drill Size	3 — 56	4 — 56	4 — 56
<b>GAS VALVE</b>			
	Redundant - Two Stage	Redundant - Two Stage	Redundant - Two Stage
<b>PILOT SAFETY DEVICE</b>			
Type	Hot Surface Ignition	Hot Surface Ignition	Hot Surface Ignition
<b>BURNERS — Type</b>			
	Multi-port In-shot	Multi-port In-shot	Multi-port In-shot
Number	3	4	4
<b>POWER CONN. — V/Ph/Hz</b> <sup>④</sup>			
	115/1/60	115/1/60	115/1/60
Ampacity (In Amps)	7.8	7.8	10.7
Max. Overcurrent Protection (Amps)	15	15	15
<b>PIPE CONN. SIZE (In.)</b>			
	1/2	1/2	1/2
<b>DIMENSIONS</b>			
	H x W x D	H x W x D	H x W x D
Crated (In.)	41-3/4 x 19-1/2 x 30-1/2	41-3/4 x 19-1/2 x 30-1/2	41-3/4 x 23 x 30-1/2
<b>WEIGHT</b>			
Shipping (Lbs.)/Net (Lbs.)	136 / 126	142 / 132	155 / 145

① Central Furnace heating designs are certified by AGA and CSA.

② For U.S. applications, above input ratings (BTUH) are up to 2,000 feet, derate 4% per 1,000 feet for elevations above 2,000 feet above sea level.  
For Canadian applications, above input ratings (BTUH) are up to 4,500 feet, derate 4% per 1,000 feet for elevations above 4,500 feet above sea level.

③ Based on U.S. government standard tests.

④ The above wiring specifications are in accordance with National Electrical Code; however, installations must comply with local codes.

⑤ Furnace ships in natural gas configuration. The LP conversion kit used with the 2 stage furnace is BAYLPSS210B or BAYLPKT210B.

⑥ First stage output capacity is approximately equal to 65% of second stage capacity.

⑦ Direct drive variable speed blower motor is an ECM constant airflow blower motor.



## Product Specifications <sup>①</sup>

MODEL	*UD2B100ACV32B	*UD2C100ACV52B	*UD2D120ACV52B	*UD2D140ACV52B
<b>TYPE</b>	Upflow/Horizontal	Upflow/Horizontal	Upflow/Horizontal	Upflow/Horizontal
<b>RATINGS</b> <sup>②</sup>				
1st Stage Input BTUH	65,000	65,000	78,000	91,000
1st Stage Capacity BTUH (ICS) <sup>③</sup>	52,000	52,000	62,400	72,800
2nd Stage Input BTUH	100,000	100,000	120,000	140,000
2nd Stage Capacity BTUH (ICS) <sup>③</sup>	80,000	79,000	97,000	111,000
Temp. rise (Min.-Max.) °F.	40 - 70	35 - 65	35 - 65	40 - 70
<b>BLOWER DRIVE</b> <sup>③⑥⑦</sup>	Direct	Direct	Direct	Direct
Diameter - Width (In.)	10 x 7	10 x 10	10 x 10	10 x 10
No. Used	1	1	1	1
Speeds (No.)	Variable	Variable	Variable	Variable
CFM vs. in. w.g.	See Airflow Table	See Airflow Table	See Airflow Table	See Airflow Table
Motor HP	1/2	1	1	1
R. P.M.	Variable	Variable	Variable	Variable
Volts/Ph/Hz	115/1/60	115/1/60	115/1/60	115/1/60
FLA	5.2	9.9	9.9	9.9
<b>COMBUSTION FAN — Type</b>	Centrifugal	Centrifugal	Centrifugal	Centrifugal
Drive - No. Speeds	Direct - 2	Direct - 2	Direct - 2	Direct - 2
Motor HP PSC [Shaded Pole] - RPM	1/75 / [1/145] - 2708/1868	1/75 / [1/145] - 2708/1868	1/60 / [1/85] - 3090/2225	1/60 - 3100/2350
Volts/Ph/Hz	115/1/60	115/1/60	115/1/60	115/1/60
FLA PSC [Shaded pole]	0.87/0.49 / [0.22/0.20]	0.87/0.49 / [0.22/0.20]	1.14/0.51 / [0.25/0.21]	1.16/0.54
<b>FILTER — Furnished?</b>	Yes	Yes	Yes	Yes
Type Recommended	High Velocity	High Velocity	High Velocity	High Velocity
Hi Vel. (No.-Size-Thk.)	1 - 17x25 - 1in.	1 - 20x25 - 1in.	1 - 24x25 - 1in.	1 - 24x25 - 1in.
<b>VENT — Size (In.)</b>	4 Round	4 Round	4 Round	4 Round
<b>HEAT EXCHANGER</b>				
Type -Fired	Alum. Steel - Type 1	Alum. Steel - Type 1	Alum. Steel - Type 1	Alum. Steel - Type 1
-Unfired				
Gauge (Fired)	20	20	20	20
<b>ORIFICES — Main</b> <sup>⑤</sup>				
Nat. Gas Qty. — Drill Size	5 — 45	5 — 45	6 — 45	7 — 45
L.P. Gas Qty. — Drill Size	5 — 56	5 — 56	6 — 56	7 — 56
<b>GAS VALVE</b>	Redundant - Two Stage	Redundant - Two Stage	Redundant - Two Stage	Redundant - Two Stage
<b>PILOT SAFETY DEVICE</b>				
Type	Hot Surface Ignition	Hot Surface Ignition	Hot Surface Ignition	Hot Surface Ignition
<b>BURNERS — Type</b>	Multi-port In-shot	Multi-port In-shot	Multi-port In-shot	Multi-port In-shot
Number	5	5	6	7
<b>POWER CONN. — V/Ph/Hz</b> <sup>④</sup>	115/1/60	115/1/60	115/1/60	115/1/60
Ampacity (In Amps)	8.1	13.9	14.3	14.3
Max. Overcurrent Protection (Amps)	15	15	15	15
<b>PIPE CONN. SIZE (In.)</b>	1/2	1/2	1/2	1/2
<b>DIMENSIONS</b>	H x W x D	H x W x D	H x W x D	H x W x D
Crated (In.)	41-3/4 x 19-1/2 x 30-1/2	41-3/4 x 23 x 30-1/2	41-3/4 x 26-1/2 x 30-1/2	41-3/4 x 26-1/2 x 30-1/2
<b>WEIGHT</b>				
Shipping (Lbs.)/Net (Lbs.)	148 / 138	175 / 165	193 / 183	197 / 187

① Central Furnace heating designs are certified by AGA and CSA.

② For U.S. applications, above input ratings (BTUH) are up to 2,000 feet, derate 4% per 1,000 feet for elevations above 2,000 feet above sea level.  
For Canadian applications, above input ratings (BTUH) are up to 4,500 feet, derate 4% per 1,000 feet for elevations above 4,500 feet above sea level.

③ Based on U.S. government standard tests.

④ The above wiring specifications are in accordance with National Electrical Code; however, installations must comply with local codes.

⑤ Furnace ships in natural gas configuration. The LP conversion kit used with the 2 stage furnace is BAYLPSS210B or BAYLPKT210B.

⑥ First stage output capacity is approximately equal to 65% of second stage capacity.

⑦ Direct drive variable speed blower motor is an ECM constant airflow blower motor.



## Product Specifications <sup>①</sup>

MODEL	*DD2B060ACV32B	*DD2B080ACV32B	*DD2C100ACV52B	*DD2D120ACV52B
<b>TYPE</b>	Downflow/Horizontal	Downflow/Horizontal	Downflow/Horizontal	Downflow/Horizontal
<b>RATINGS</b> <sup>②</sup>				
1st Stage Input BTUH	39,000	52,000	65,000	78,000
1st Stage Capacity BTUH (ICS) <sup>③</sup>	31,200	41,600	52,000	62,400
2nd Stage Input BTUH	60,000	80,000	100,000	120,000
2nd Stage Capacity BTUH (ICS) <sup>③</sup>	48,000	63,000	81,000	95,000
Temp. rise (Min.-Max.) °F	35 - 65	35 - 65	35 - 65	35 - 65
<b>BLOWER DRIVE</b> <sup>③⑥⑦</sup>	Direct	Direct	Direct	Direct
Diameter - Width (In.)	10 x 7	10 x 7	11 x 10	11 x 10
No. Used	1	1	1	1
Speeds (No.)	Variable	Variable	Variable	Variable
CFM vs. in. w.g.	See Airflow Table	See Airflow Table	See Airflow Table	See Airflow Table
Motor HP	1/2	1/2	1	1
R.P.M.	Variable	Variable	Variable	Variable
Volts/Ph/Hz	115/1/60	115/1/60	115/1/60	115/1/60
FLA	5.2	5.2	9.9	9.9
<b>COMBUSTION FAN — Type</b>	Centrifugal	Centrifugal	Centrifugal	Centrifugal
Drive - No. Speeds	Direct - 2	Direct - 2	Direct - 2	Direct - 2
Motor HP PSC [Shaded Pole] - RPM	1/100 / [1/145] - 2543/1727	1/100 / [1/145] - 2543/1727	1/75 / [1/145] - 2708/1868	1/60 / [1/85] - 3090/2225
Volts/Ph/Hz	115/1/60	115/1/60	115/1/60	115/1/60
FLA PSC [Shaded pole]	0.70/0.40 / [0.23/0.20]	0.70/0.40 / [0.23/0.20]	0.87/0.49 / [0.22/0.20]	1.14/0.51 / [0.25/0.21]
<b>FILTER — Furnished?</b>	Yes	Yes	Yes	Yes
Type Recommended	High Velocity	High Velocity	High Velocity	High Velocity
Hi Vel. (No.-Size-Thk.)	2 - 14x20 - 1in.	2 - 14x20 - 1in.	2 - 16x20 - 1in.	2 - 16x20 - 1in.
<b>VENT — Size (In.)</b>	4 Round	4 Round	4 Round	4 Round
<b>HEAT EXCHANGER</b>				
Type -Fired	Alum. Steel - Type 1	Alum. Steel - Type 1	Alum. Steel - Type 1	Alum. Steel - Type 1
-Unfired				
Gauge (Fired)	20	20	20	20
<b>ORIFICES — Main</b> <sup>⑤</sup>				
Nat. Gas Qty. — Drill Size	3 — 45	4 — 45	5 — 45	6 — 45
L.P. Gas Qty. — Drill Size	3 — 56	4 — 56	5 — 56	6 — 56
<b>GAS VALVE</b>	Redundant - Two Stage	Redundant - Two Stage	Redundant - Two Stage	Redundant - Two Stage
<b>PILOT SAFETY DEVICE</b>				
Type	Hot Surface Ignition	Hot Surface Ignition	Hot Surface Ignition	Hot Surface Ignition
<b>BURNERS — Type</b>	Multi-port In-shot	Multi-port In-shot	Multi-port In-shot	Multi-port In-shot
Number	3	4	5	6
<b>POWER CONN. — V/Ph/Hz</b> <sup>④</sup>	115/1/60	115/1/60	115/1/60	115/1/60
Ampacity (In Amps)	7.8	7.8	13.9	14.3
Max. Overcurrent Protection (Amps)	15	15	15	15
<b>PIPE CONN. SIZE (In.)</b>	1/2	1/2	1/2	1/2
<b>DIMENSIONS</b>	H x W x D	H x W x D	H x W x D	H x W x D
Crated (In.)	41-3/4 x 19-1/2 x 30-1/2	41-3/4 x 19-1/2 x 30-1/2	41-3/4 x 23 x 30-1/2	41-3/4 x 26-1/2 x 30-1/2
<b>WEIGHT</b>				
Shipping (Lbs.)/Net (Lbs.)	140 / 130	146 / 136	166 / 156	197 / 187

① Central Furnace heating designs are certified by AGA and CSA.

② For U.S. applications, above input ratings (BTUH) are up to 2,000 feet, derate 4% per 1,000 feet for elevations above 2,000 feet above sea level.  
For Canadian applications, above input ratings (BTUH) are up to 4,500 feet, derate 4% per 1,000 feet for elevations above 4,500 feet above sea level.

③ Based on U.S. government standard tests.

④ The above wiring specifications are in accordance with National Electrical Code; however, installations must comply with local codes.

⑤ Furnace ships in natural gas configuration. The LP conversion kit used with the 2 stage furnace is BAYLPSS210B or BAYLPKT210B.

⑥ First stage output capacity is approximately equal to 65% of second stage capacity.

⑦ Direct drive variable speed blower motor is an ECM constant airflow blower motor.

# Performance Data



*UD2B060ACV32B Furnace Heating Airflow (CFM) and Power (Watts) vs. External Static Pressure							
			0.1	0.3	0.5	0.7	0.9
HEATING 1ST STAGE	533	CFM	523	551	551	547	541
		TEMP RISE	55	52	52	53	53
		WATTS	52	83	103	119	150
	650	CFM	651	674	673	667	657
		TEMP RISE	44	43	43	43	44
		WATTS	76	110	129	145	184
	689	CFM	694	714	714	707	696
		TEMP RISE	41	40	40	41	41
		WATTS	87	122	140	155	197
HEATING 2ND STAGE	820	CFM	838	851	850	841	826
		TEMP RISE	53	52	52	53	54
		WATTS	135	171	187	197	243
	1000	CFM	1035	1039	1038	1024	1006
		TEMP RISE	43	43	43	43	44
		WATTS	227	263	277	271	318
	1060	CFM	1101	1102	1101	1086	1066
		TEMP RISE	40	40	40	41	42
		WATTS	265	300	313	301	346

*UD2B060ACV32B Furnace Cooling Airflow (CFM) and Power (Watts) vs. External Static Pressure with Filter								
OD	AIRFLOW		0.1	0.3	0.5	0.7	0.9	
1.5	290	CFM	371	433	442	439	429	
		WATTS	28	57	84	110	137	
	350	CFM	547	571	573	564	549	
		WATTS	40	68	96	125	152	
	400	CFM	633	647	643	633	618	
		WATTS	52	83	111	141	171	
	450	CFM	701	715	711	704	694	
		WATTS	64	97	128	160	193	
	2.0	290	CFM	546	573	574	567	554
			WATTS	49	80	108	139	168
		350	CFM	725	739	738	728	717
			WATTS	70	104	137	166	201
400		CFM	832	842	837	829	817	
		WATTS	94	131	166	201	237	
450		CFM	935	943	939	930	921	
		WATTS	122	163	202	239	278	
2.5		290	CFM	697	716	712	704	693
			WATTS	74	110	145	177	211
		350	CFM	909	915	911	904	895
			WATTS	116	155	193	230	266
	400	CFM	1040	1042	1043	1038	1027	
		WATTS	160	204	247	291	332	
	450	CFM	1178	1176	1175	1169	1164	
		WATTS	220	270	318	365	413	
	3.0	290	CFM	849	860	859	850	836
			WATTS	114	155	196	230	268
		350	CFM	1099	1097	1097	1089	1082
			WATTS	183	228	274	318	363
400		CFM	1253	1250	1250	1243	1238	
		WATTS	258	312	364	415	466	
450		CFM	1406	1403	1405	1354	1281	
		WATTS	363	420	484	503	500	

**NOTES:**

- \*FIRST LETTER MAY BE "A" OR "T"
- \*\*FACTORY SETTING
- CONTINUOUS FAN SPEED SETTING: HEATING OR COOLING AIRFLOW IS APPROXIMATELY 50% OF SELECTED COOLING VALUE.
- WITH VARIABLE SPEED OUTDOOR UNIT APPLICATION, THE LOW SPEED AIRFLOWS ARE APPROXIMATELY 30% OF LISTED VALUES.
- LOW 350 CFM/TON IS RECOMMENDED FOR VARIABLE SPEED APPLICATIONS FOR COMFORT & HUMID CLIMATE SETTING: NORMAL IS 400 CFM/TON: HIGH 450 CFM/TON IS FOR DRY CLIMATE SETTING.
- CONTINUOUS FAN MODE DURING COOLING OPERATION MAY NOT BE APPROPRIATE IN HUMID CLIMATES. IF THE INDOOR AIR EXCEEDS 60% RELATIVE HUMIDITY OR SIMPLY FEELS UNCOMFORTABLY HUMID, IT IS RECOMMENDED THAT THE FAN ONLY BE USED IN THE AUTO MODE.



# Performance Data

*UD2B080ACV32B Furnace Heating Airflow (CFM) and Power (Watts) vs. External Static Pressure							
			0.1	0.3	0.5	0.7	0.9
HEATING 1ST STAGE	780	CFM	804	833	849	863	873
		TEMP RISE	48	46	45	44	44
		WATTS	66	110	190	229	278
	897	CFM	930	950	958	960	958
		TEMP RISE	41	40	40	40	40
		WATTS	102	153	250	283	328
	955.5	CFM	993	1009	1012	1008	1001
		TEMP RISE	39	38	38	38	38
		WATTS	124	176	279	308	350
HEATING 2ND STAGE	1200	CFM	1258	1255	1239	1210	1179
		TEMP RISE	47	47	48	49	50
		WATTS	241	279	395	396	423
	1380	CFM	1453	1436	1407	1359	1310
		TEMP RISE	41	41	42	43	45
		WATTS	354	362	475	446	457
	1470	CFM	1550	1526	1490	1433	1375
		TEMP RISE	38	39	40	41	43
		WATTS	419	407	513	465	467

*UD2B080ACV32B Furnace Cooling Airflow (CFM) and Power (Watts) vs. External Static Pressure with Filter							
OD	AIRFLOW		0.1	0.3	0.5	0.7	0.9
2.5	290	CFM	709	736	734	727	716
		WATTS	74	115	148	183	218
	350	CFM	916	937	939	936	929
		WATTS	109	154	193	233	272
	400	CFM	1060	1071	1073	1072	1067
		WATTS	156	204	250	295	340
	450	CFM	1199	1208	1207	1209	1209
		WATTS	216	269	322	374	428
3**	290	CFM	878	891	897	886	875
		WATTS	117	158	200	238	276
	350	CFM	1110	1124	1125	1125	1121
		WATTS	178	227	275	323	369
	400**	CFM	1277	1281	1282	1289	1291
		WATTS	263	318	375	434	493
	450	CFM	1445	1444	1445	1375	1300
		WATTS	370	433	498	503	502
3.5	290	CFM	1040	1044	1049	1042	1034
		WATTS	172	220	269	315	359
	350	CFM	1303	1302	1300	1299	1296
		WATTS	281	335	390	444	498
	400	CFM	1485	1496	1453	1374	1298
		WATTS	415	477	507	503	500
	450	CFM	1603	1530	1450	1369	1288
		WATTS	514	510	505	501	498

NOTES:

- \*FIRST LETTER MAY BE "A" OR "T"
- \*\*FACTORY SETTING
- CONTINUOUS FAN SPEED SETTING: HEATING OR COOLING AIRFLOW IS APPROXIMATELY 50% OF SELECTED COOLING VALUE.
- WITH VARIABLE SPEED OUTDOOR UNIT APPLICATION, THE LOW SPEED AIRFLOWS ARE APPROXIMATELY 30% OF LISTED VALUES.
- LOW 350 CFM/TON IS RECOMMENDED FOR VARIABLE SPEED APPLICATIONS FOR COMFORT & HUMID CLIMATE SETTING: NORMAL IS 400 CFM/TON: HIGH 450 CFM/TON IS FOR DRY CLIMATE SETTING.
- CONTINUOUS FAN MODE DURING COOLING OPERATION MAY NOT BE APPROPRIATE IN HUMID CLIMATES. IF THE INDOOR AIR EXCEEDS 60% RELATIVE HUMIDITY OR SIMPLY FEELS UNCOMFORTABLY HUMID, IT IS RECOMMENDED THAT THE FAN ONLY BE USED IN THE AUTO MODE.

# Performance Data



*UD2C080ACV42B Furnace Heating Airflow (CFM) and Power (Watts) vs. External Static Pressure							
			0.1	0.3	0.5	0.7	0.9
HEATING 1ST STAGE	722	CFM	760	776	774	768	764
		TEMP RISE	50	49	50	50	50
		WATTS	86	126	191	188	231
	819	CFM	844	859	858	851	846
		TEMP RISE	45	45	45	45	45
		WATTS	88	133	207	200	253
	897	CFM	911	926	924	917	911
		TEMP RISE	42	41	41	42	42
		WATTS	93	142	224	211	273
HEATING 2ND STAGE	1110	CFM	1094	1108	1107	1099	1088
		TEMP RISE	54	53	53	54	54
		WATTS	124	183	287	258	337
	1260	CFM	1222	1236	1236	1226	1213
		TEMP RISE	48	48	48	48	49
		WATTS	160	224	347	302	389
	1380	CFM	1325	1338	1338	1329	1313
		TEMP RISE	45	44	44	44	45
		WATTS	197	266	405	344	435

*UD2C080ACV42B Furnace Cooling Airflow (CFM) and Power (Watts) vs. External Static Pressure with Filter								
OD	AIRFLOW		0.1	0.3	0.5	0.7	0.9	
2.5	290	CFM	732	758	759	744	728	
		WATTS	61	100	137	171	207	
	350	CFM	893	905	905	892	874	
		WATTS	90	130	172	214	253	
	400	CFM	1014	1024	1019	1013	995	
		WATTS	117	163	206	251	294	
	450	CFM	1091	1107	1110	1104	1101	
		WATTS	137	188	237	284	337	
	3.0	290	CFM	888	900	897	889	876
			WATTS	86	130	170	212	253
		350	CFM	1069	1081	1081	1068	1063
			WATTS	121	179	226	270	321
400		CFM	1202	1216	1211	1202	1190	
		WATTS	175	231	281	329	380	
450		CFM	1307	1323	1328	1325	1322	
		WATTS	202	277	338	392	453	
3.5	290	CFM	1034	1050	1043	1034	1024	
		WATTS	112	170	213	257	305	
	350	CFM	1190	1208	1212	1206	1203	
		WATTS	156	223	279	329	383	
	400	CFM	1363	1370	1378	1377	1370	
		WATTS	240	301	364	425	481	
	450	CFM	1565	1572	1575	1558	1516	
		WATTS	371	436	510	565	595	
4.0	290	CFM	1150	1154	1147	1142	1132	
		WATTS	178	231	276	330	374	
	350	CFM	1363	1370	1378	1377	1370	
		WATTS	240	301	364	425	481	
	400	CFM	1594	1601	1603	1584	1536	
		WATTS	390	456	531	585	611	
	450	CFM	1824	1832	1829	1791	1703	
		WATTS	539	610	697	746	742	

NOTES:

1. \*FIRST LETTER MAY BE "A" OR "T"
2. \*\*FACTORY SETTING
3. CONTINUOUS FAN SPEED SETTING: HEATING OR COOLING AIRFLOW IS APPROXIMATELY 50% OF SELECTED COOLING VALUE.
4. WITH VARIABLE SPEED OUTDOOR UNIT APPLICATION, THE LOW SPEED AIRFLOWS ARE APPROXIMATELY 30% OF LISTED VALUES.
5. LOW 350 CFM/TON IS RECOMMENDED FOR VARIABLE SPEED APPLICATIONS FOR COMFORT & HUMID CLIMATE SETTING: NORMAL IS 400 CFM/TON: HIGH 450 CFM/TON IS FOR DRY CLIMATE SETTING.
6. CONTINUOUS FAN MODE DURING COOLING OPERATION MAY NOT BE APPROPRIATE IN HUMID CLIMATES. IF THE INDOOR AIR EXCEEDS 60% RELATIVE HUMIDITY OR SIMPLY FEELS UNCOMFORTABLY HUMID, IT IS RECOMMENDED THAT THE FAN ONLY BE USED IN THE AUTO MODE.



# Performance Data

*UD2B100ACV32B Furnace Heating Airflow (CFM) and Power (Watts) vs. External Static Pressure							
			0.1	0.3	0.5	0.7	0.9
HEATING 1ST STAGE	839	CFM	842	848	841	828	812
		TEMP RISE	57	57	57	58	59
		WATTS	79	178	188	204	236
	904	CFM	907	912	906	893	875
		TEMP RISE	53	53	53	54	55
		WATTS	97	207	217	231	262
	969	CFM	973	976	971	958	939
		TEMP RISE	49	49	49	50	51
		WATTS	118	240	249	261	291
HEATING 2ND STAGE	1290	CFM	1298	1295	1293	1278	1253
		TEMP RISE	57	57	57	58	59
		WATTS	258	451	456	452	459
	1390	CFM	1399	1394	1393	1378	1351
		TEMP RISE	53	53	53	54	55
		WATTS	315	533	537	527	521
	1490	CFM	1500	1493	1493	1478	1448
		TEMP RISE	49	49	49	50	51
		WATTS	378	623	627	608	588

*UD2B100ACV32B Furnace Cooling Airflow (CFM) and Power (Watts) vs. External Static Pressure with Filter							
OD	AIRFLOW		0.1	0.3	0.5	0.7	0.9
1.5	290	CFM	424	442	438	424	412
		WATTS	25	53	78	102	127
	350	CFM	514	533	526	512	493
		WATTS	33	65	91	118	143
	400	CFM	603	615	606	592	576
		WATTS	44	79	107	135	164
	450	CFM	686	691	676	667	652
		WATTS	65	95	125	154	186
2.0	290	CFM	575	588	582	569	552
		WATTS	40	75	101	130	158
	350	CFM	712	716	703	691	677
		WATTS	70	101	130	159	193
	400	CFM	801	806	800	783	772
		WATTS	84	127	160	192	227
	450	CFM	908	910	905	895	879
		WATTS	112	161	197	232	267
2.5	290	CFM	732	738	729	716	700
		WATTS	67	107	136	168	200
	350	CFM	884	884	880	867	851
		WATTS	104	151	186	220	256
	400	CFM	999	1004	1001	990	978
		WATTS	146	199	239	279	318
	450	CFM	1132	1134	1131	1123	1114
		WATTS	204	262	310	354	399
3.0	290	CFM	878	882	875	859	844
		WATTS	104	150	185	220	254
	350	CFM	1055	1057	1054	1042	1036
		WATTS	178	224	266	307	350
	400	CFM	1205	1202	1200	1195	1190
		WATTS	239	305	353	402	451
	450	CFM	1351	1354	1351	1323	1253
		WATTS	337	409	469	503	500

NOTES:

1. \*FIRST LETTER MAY BE "A" OR "T"
2. \*\*FACTORY SETTING
3. CONTINUOUS FAN SPEED SETTING: HEATING OR COOLING AIRFLOW IS APPROXIMATELY 50% OF SELECTED COOLING VALUE.
4. WITH VARIABLE SPEED OUTDOOR UNIT APPLICATION, THE LOW SPEED AIRFLOWS ARE APPROXIMATELY 30% OF LISTED VALUES.
5. LOW 350 CFM/TON IS RECOMMENDED FOR VARIABLE SPEED APPLICATIONS FOR COMFORT & HUMID CLIMATE SETTING: NORMAL IS 400 CFM/TON: HIGH 450 CFM/TON IS FOR DRY CLIMATE SETTING.
6. CONTINUOUS FAN MODE DURING COOLING OPERATION MAY NOT BE APPROPRIATE IN HUMID CLIMATES. IF THE INDOOR AIR EXCEEDS 60% RELATIVE HUMIDITY OR SIMPLY FEELS UNCOMFORTABLY HUMID, IT IS RECOMMENDED THAT THE FAN ONLY BE USED IN THE AUTO MODE.

# Performance Data



*UD2C100ACV52B Furnace Heating Airflow (CFM) and Power (Watts) vs. External Static Pressure							
			0.1	0.3	0.5	0.7	0.9
HEATING 1ST STAGE	845	CFM	738	806	847	881	908
		TEMP RISE	65	59	57	54	53
		WATTS	59	84	128	170	222
	1001	CFM	915	971	1003	1028	1046
		TEMP RISE	52	49	48	47	46
		WATTS	70	129	197	250	315
	1073	CFM	996	1047	1074	1095	1109
		TEMP RISE	48	46	45	44	43
		WATTS	84	155	232	288	357
HEATING 2ND STAGE	1300	CFM	1254	1288	1302	1310	1310
		TEMP RISE	59	57	57	56	56
		WATTS	162	261	357	413	489
	1540	CFM	1526	1543	1543	1536	1523
		TEMP RISE	48	48	48	48	48
		WATTS	303	411	512	553	623
	1650	CFM	1650	1659	1653	1640	1620
		TEMP RISE	45	44	45	45	46
		WATTS	387	493	590	620	683

*UD2C100ACV52B Furnace Cooling Airflow (CFM) and Power (Watts) vs. External Static Pressure with Filter								
OD	AIRFLOW		0.1	0.3	0.5	0.7	0.9	
3.0	290	CFM	753	817	844	848	851	
		WATTS	69	115	161	206	253	
	350	CFM	972	1030	1057	1071	1067	
		WATTS	105	165	218	271	321	
	400	CFM	1140	1176	1193	1210	1214	
		WATTS	153	214	273	333	392	
	450	CFM	1284	1306	1314	1325	1337	
		WATTS	212	276	337	406	474	
	3.5	290	CFM	939	984	1009	1017	1015
			WATTS	97	150	198	254	302
		350	CFM	1141	1168	1181	1204	1203
			WATTS	153	208	265	330	386
400		CFM	1415	1455	1473	1486	1500	
		WATTS	246	324	395	467	543	
450		CFM	1543	1569	1567	1564	1574	
		WATTS	337	413	482	552	638	
4.0		290	CFM	1083	1115	1129	1149	1147
			WATTS	137	195	249	311	366
		350	CFM	1415	1455	1473	1486	1500
			WATTS	246	324	395	467	543
	400	CFM	1619	1640	1650	1653	1654	
		WATTS	364	447	525	601	678	
	450	CFM	1855	1869	1874	1873	1867	
		WATTS	526	614	699	784	866	
	5.0	290	CFM	1390	1412	1417	1413	1426
			WATTS	257	327	395	457	532
		350	CFM	1740	1752	1755	1756	1749
			WATTS	468	557	629	718	796
400		CFM	2095	2102	2086	2027	1941	
		WATTS	758	860	937	959	959	
450		CFM	2277	2197	2112	2035	1950	
		WATTS	972	973	963	970	969	

NOTES:

1. \*FIRST LETTER MAY BE "A" OR "T"
2. \*\*FACTORY SETTING
3. CONTINUOUS FAN SPEED SETTING: HEATING OR COOLING AIRFLOW IS APPROXIMATELY 50% OF SELECTED COOLING VALUE.
4. WITH VARIABLE SPEED OUTDOOR UNIT APPLICATION, THE LOW SPEED AIRFLOWS ARE APPROXIMATELY 30% OF LISTED VALUES.
5. LOW 350 CFM/TON IS RECOMMENDED FOR VARIABLE SPEED APPLICATIONS FOR COMFORT & HUMID CLIMATE SETTING: NORMAL IS 400 CFM/TON: HIGH 450 CFM/TON IS FOR DRY CLIMATE SETTING.
6. CONTINUOUS FAN MODE DURING COOLING OPERATION MAY NOT BE APPROPRIATE IN HUMID CLIMATES. IF THE INDOOR AIR EXCEEDS 60% RELATIVE HUMIDITY OR SIMPLY FEELS UNCOMFORTABLY HUMID, IT IS RECOMMENDED THAT THE FAN ONLY BE USED IN THE AUTO MODE.



# Performance Data

*UD2D120ACV52B Furnace Heating Airflow (CFM) and Power (Watts) vs. External Static Pressure							
			0.1	0.3	0.5	0.7	0.9
HEATING 1ST STAGE	845	CFM	844	869	894	915	940
		TEMP RISE	68	66	64	63	61
		WATTS	87	132	146	185	220
	1073	CFM	1071	1090	1105	1116	1128
		TEMP RISE	54	53	52	52	51
		WATTS	126	186	227	296	345
	1235	CFM	1233	1248	1255	1259	1262
		TEMP RISE	47	46	46	46	46
		WATTS	175	244	297	380	432
HEATING 2ND STAGE	1300	CFM	1298	1311	1316	1317	1316
		TEMP RISE	68	67	67	67	67
		WATTS	200	272	327	415	467
	1650	CFM	1647	1651	1640	1626	1606
		TEMP RISE	54	54	54	54	55
		WATTS	385	469	514	611	647
	1900	CFM	1897	1894	1872	1846	1812
		TEMP RISE	47	47	47	48	49
		WATTS	569	657	674	762	770

*UD2D120ACV52B Furnace Cooling Airflow (CFM) and Power (Watts) vs. External Static Pressure with Filter							
OD	AIRFLOW		0.1	0.3	0.5	0.7	0.9
3.5	290	CFM	1010	1036	1038	1039	1033
		WATTS	118	168	216	266	315
	350	CFM	1212	1228	1230	1228	1223
		WATTS	167	237	291	345	403
	400	CFM	1407	1420	1417	1416	1416
		WATTS	240	318	380	441	508
450	CFM	1580	1584	1584	1581	1580	
	WATTS	342	415	484	553	624	
4.0	290	CFM	1141	1159	1165	1164	1157
		WATTS	157	211	263	316	373
	350	CFM	1407	1420	1417	1416	1416
		WATTS	240	318	380	441	508
	400	CFM	1595	1609	1610	1604	1600
		WATTS	356	428	500	571	639
450	CFM	1814	1817	1813	1801	1788	
	WATTS	505	582	655	729	803	
5.0	290	CFM	1441	1417	1425	1421	1422
		WATTS	267	322	386	447	512
	350	CFM	1765	1773	1771	1768	1762
		WATTS	457	550	627	705	780
	400	CFM	2014	2011	2004	1992	1945
		WATTS	662	768	849	932	974
450	CFM	2210	2193	2116	2038	1954	
	WATTS	902	990	989	984	979	

NOTES:

- \*FIRST LETTER MAY BE "A" OR "T"
- \*\*FACTORY SETTING
- CONTINUOUS FAN SPEED SETTING: HEATING OR COOLING AIRFLOW IS APPROXIMATELY 50% OF SELECTED COOLING VALUE.
- WITH VARIABLE SPEED OUTDOOR UNIT APPLICATION, THE LOW SPEED AIRFLOWS ARE APPROXIMATELY 30% OF LISTED VALUES.
- LOW 350 CFM/TON IS RECOMMENDED FOR VARIABLE SPEED APPLICATIONS FOR COMFORT & HUMID CLIMATE SETTING: NORMAL IS 400 CFM/TON: HIGH 450 CFM/TON IS FOR DRY CLIMATE SETTING.
- CONTINUOUS FAN MODE DURING COOLING OPERATION MAY NOT BE APPROPRIATE IN HUMID CLIMATES. IF THE INDOOR AIR EXCEEDS 60% RELATIVE HUMIDITY OR SIMPLY FEELS UNCOMFORTABLY HUMID, IT IS RECOMMENDED THAT THE FAN ONLY BE USED IN THE AUTO MODE.

# Performance Data



*UD2D140ACV52B Furnace Heating Airflow (CFM) and Power (Watts) vs. External Static Pressure							
			0.1	0.3	0.5	0.7	0.9
HEATING 1ST STAGE	1047	CFM	1012	1048	1068	1079	1095
		TEMP RISE	66	64	63	62	61
		WATTS	99	162	211	269	372
	1248	CFM	1217	1240	1250	1251	1255
		TEMP RISE	55	54	54	54	53
		WATTS	170	251	320	383	502
	1320	CFM	1290	1308	1314	1312	1311
		TEMP RISE	52	51	51	51	51
		WATTS	203	288	360	423	546
HEATING 2ND STAGE	1610	CFM	1587	1584	1577	1560	1541
		TEMP RISE	65	65	65	66	67
		WATTS	378	458	531	587	721
	1920	CFM	1903	1879	1857	1825	1787
		TEMP RISE	54	55	56	57	58
		WATTS	637	682	729	763	895
	2030	CFM	2015	1984	1956	1919	1874
		TEMP RISE	51	52	53	54	55
		WATTS	746	771	803	825	955

*UD2D120ACV52B Furnace Cooling Airflow (CFM) and Power (Watts) vs. External Static Pressure with Filter							
OD	AIRFLOW		0.1	0.3	0.5	0.7	0.9
3.5	290	CFM	1010	1036	1038	1039	1033
		WATTS	118	168	216	266	315
	350	CFM	1212	1228	1230	1228	1223
		WATTS	167	237	291	345	403
	400	CFM	1407	1420	1417	1416	1416
		WATTS	240	318	380	441	508
450	CFM	1580	1584	1584	1581	1580	
	WATTS	342	415	484	553	624	
4.0	290	CFM	1141	1159	1165	1164	1157
		WATTS	157	211	263	316	373
	350	CFM	1407	1420	1417	1416	1416
		WATTS	240	318	380	441	508
	400	CFM	1595	1609	1610	1604	1600
		WATTS	356	428	500	571	639
450	CFM	1814	1817	1813	1801	1788	
	WATTS	505	582	655	729	803	
5.0	290	CFM	1441	1417	1425	1421	1422
		WATTS	267	322	386	447	512
	350	CFM	1765	1773	1771	1768	1762
		WATTS	457	550	627	705	780
	400	CFM	2014	2011	2004	1992	1945
		WATTS	662	768	849	932	974
450	CFM	2210	2193	2116	2038	1954	
	WATTS	902	990	989	984	979	

**NOTES:**

1. \*FIRST LETTER MAY BE "A" OR "T"
2. \*\*FACTORY SETTING
3. CONTINUOUS FAN SPEED SETTING: HEATING OR COOLING AIRFLOW IS APPROXIMATELY 50% OF SELECTED COOLING VALUE.
4. WITH VARIABLE SPEED OUTDOOR UNIT APPLICATION, THE LOW SPEED AIRFLOWS ARE APPROXIMATELY 30% OF LISTED VALUES.
5. LOW 350 CFM/TON IS RECOMMENDED FOR VARIABLE SPEED APPLICATIONS FOR COMFORT & HUMID CLIMATE SETTING: NORMAL IS 400 CFM/TON: HIGH 450 CFM/TON IS FOR DRY CLIMATE SETTING.
6. CONTINUOUS FAN MODE DURING COOLING OPERATION MAY NOT BE APPROPRIATE IN HUMID CLIMATES. IF THE INDOOR AIR EXCEEDS 60% RELATIVE HUMIDITY OR SIMPLY FEELS UNCOMFORTABLY HUMID, IT IS RECOMMENDED THAT THE FAN ONLY BE USED IN THE AUTO MODE.



# Performance Data

*DD2B060ACV32B Furnace Heating Airflow (CFM) and Power (Watts) vs. External Static Pressure							
			0.1	0.3	0.5	0.7	0.9
HEATING 1ST STAGE	559	CFM	554	585	587	579	571
		TEMP RISE	52	49	49	50	50
		WATTS	50	73	85	124	171
	624	CFM	622	652	655	648	637
		TEMP RISE	46	44	44	44	45
		WATTS	62	86	96	141	192
	689	CFM	690	719	723	716	704
		TEMP RISE	42	40	40	40	41
		WATTS	78	102	110	160	216
HEATING 2ND STAGE	860	CFM	869	896	902	896	879
		TEMP RISE	51	49	49	49	50
		WATTS	132	157	165	223	292
	960	CFM	974	999	1006	1001	981
		TEMP RISE	45	44	44	44	45
		WATTS	173	198	210	269	345
	1060	CFM	1078	1102	1111	1107	1083
		TEMP RISE	41	40	40	40	41
		WATTS	220	246	263	322	405

*DD2B060ACV32B Furnace Cooling Airflow (CFM) and Power (Watts) vs. External Static Pressure with Filter							
OD	AIRFLOW		0.1	0.3	0.5	0.7	0.9
1.5	290	CFM	422	465	473	462	449
		WATTS	26	49	67	106	131
	350	CFM	518	550	562	554	535
		WATTS	34	60	75	122	149
	400	CFM	606	631	633	631	612
		WATTS	43	74	102	134	165
450	CFM	683	705	705	699	687	
	WATTS	59	88	99	163	190	
2.0	290	CFM	583	609	614	610	591
		WATTS	42	68	82	135	162
	350	CFM	708	730	729	722	712
		WATTS	57	91	122	155	190
	400	CFM	805	837	830	823	817
		WATTS	75	114	150	183	220
450	CFM	896	926	930	921	911	
	WATTS	98	142	182	220	256	
2.5	290	CFM	732	757	754	747	738
		WATTS	70	100	110	180	206
	350	CFM	873	904	905	896	887
		WATTS	112	146	152	245	265
	400	CFM	1000	1030	1034	1029	1026
		WATTS	126	176	222	264	308
450	CFM	1144	1169	1178	1174	1146	
	WATTS	213	253	252	392	394	
3.0	290	CFM	883	909	918	913	893
		WATTS	111	144	151	242	263
	350	CFM	1056	1083	1091	1086	1083
		WATTS	179	217	218	343	351
	400	CFM	1223	1243	1260	1257	1252
		WATTS	210	271	329	384	436
450	CFM	1404	1421	1442	1444	1362	
	WATTS	301	367	439	505	504	

NOTES:

- \*FIRST LETTER MAY BE "A" OR "T"
- \*\*FACTORY SETTING
- CONTINUOUS FAN SPEED SETTING: HEATING OR COOLING AIRFLOW IS APPROXIMATELY 50% OF SELECTED COOLING VALUE.
- WITH VARIABLE SPEED OUTDOOR UNIT APPLICATION, THE LOW SPEED AIRFLOWS ARE APPROXIMATELY 30% OF LISTED VALUES.
- LOW 350 CFM/TON IS RECOMMENDED FOR VARIABLE SPEED APPLICATIONS FOR COMFORT & HUMID CLIMATE SETTING: NORMAL IS 400 CFM/TON: HIGH 450 CFM/TON IS FOR DRY CLIMATE SETTING.
- CONTINUOUS FAN MODE DURING COOLING OPERATION MAY NOT BE APPROPRIATE IN HUMID CLIMATES. IF THE INDOOR AIR EXCEEDS 60% RELATIVE HUMIDITY OR SIMPLY FEELS UNCOMFORTABLY HUMID, IT IS RECOMMENDED THAT THE FAN ONLY BE USED IN THE AUTO MODE.

# Performance Data



*DD2B080ACV32B Furnace Heating Airflow (CFM) and Power (Watts) vs. External Static Pressure							
			0.1	0.3	0.5	0.7	0.9
HEATING 1ST STAGE	650	CFM	644	680	695	703	717
		TEMP RISE	60	56	55	55	53
		WATTS	66	91	108	129	167
	728	CFM	723	754	766	770	778
		TEMP RISE	53	51	50	50	49
		WATTS	70	106	134	164	203
	819	CFM	816	841	849	848	849
		TEMP RISE	47	46	45	45	45
		WATTS	82	127	167	205	244
HEATING 2ND STAGE	1000	CFM	1001	1013	1014	1005	990
		TEMP RISE	59	58	58	59	60
		WATTS	131	186	237	284	319
	1120	CFM	1123	1128	1123	1108	1083
		TEMP RISE	53	52	53	53	54
		WATTS	181	236	288	335	365
	1260	CFM	1266	1261	1250	1229	1192
		TEMP RISE	47	47	47	48	49
		WATTS	256	306	351	394	413

*DD2B080ACV32B Furnace Cooling Airflow (CFM) and Power (Watts) vs. External Static Pressure with Filter							
OD	AIRFLOW		0.1	0.3	0.5	0.7	0.9
2.5	290	CFM	723	742	738	726	715
		WATTS	63	98	130	162	196
	350	CFM	871	891	891	881	868
		WATTS	94	138	176	210	247
	400	CFM	1006	1019	1022	1013	1000
		WATTS	134	182	224	265	307
450	CFM	1123	1131	1129	1120	1108	
	WATTS	182	235	282	326	367	
3.0	290	CFM	868	891	884	877	866
		WATTS	95	137	176	208	245
	350	CFM	1055	1059	1063	1052	1045
		WATTS	155	199	246	288	329
	400	CFM	1193	1192	1202	1200	1193
		WATTS	216	266	320	372	422
450	CFM	1355	1359	1359	1356	1300	
	WATTS	308	368	427	484	500	
3.5	290	CFM	1026	1039	1040	1029	1017
		WATTS	142	188	232	272	311
	350	CFM	1225	1231	1239	1235	1231
		WATTS	224	281	336	386	437
	400	CFM	1412	1408	1410	1397	1319
		WATTS	333	390	462	509	504
450	CFM	1596	1544	1469	1387	1315	
	WATTS	492	516	512	509	508	

NOTES:

- \*FIRST LETTER MAY BE "A" OR "T"
- \*\*FACTORY SETTING
- CONTINUOUS FAN SPEED SETTING: HEATING OR COOLING AIRFLOW IS APPROXIMATELY 50% OF SELECTED COOLING VALUE.
- WITH VARIABLE SPEED OUTDOOR UNIT APPLICATION, THE LOW SPEED AIRFLOWS ARE APPROXIMATELY 30% OF LISTED VALUES.
- LOW 350 CFM/TON IS RECOMMENDED FOR VARIABLE SPEED APPLICATIONS FOR COMFORT & HUMID CLIMATE SETTING: NORMAL IS 400 CFM/TON: HIGH 450 CFM/TON IS FOR DRY CLIMATE SETTING.
- CONTINUOUS FAN MODE DURING COOLING OPERATION MAY NOT BE APPROPRIATE IN HUMID CLIMATES. IF THE INDOOR AIR EXCEEDS 60% RELATIVE HUMIDITY OR SIMPLY FEELS UNCOMFORTABLY HUMID, IT IS RECOMMENDED THAT THE FAN ONLY BE USED IN THE AUTO MODE.



# Performance Data

*DD2C100ACV52B Furnace Heating Airflow (CFM) and Power (Watts) vs. External Static Pressure							
			0.1	0.3	0.5	0.7	0.9
HEATING 1ST STAGE	819	CFM	834	845	853	862	870
		TEMP RISE	57	57	56	56	55
		WATTS	71	138	155	178	225
	891	CFM	904	913	919	925	930
		TEMP RISE	53	52	52	52	52
		WATTS	78	157	178	206	258
	1001	CFM	1012	1019	1021	1023	1023
		TEMP RISE	47	47	47	47	47
		WATTS	95	192	216	250	310
HEATING 2ND STAGE	1260	CFM	1266	1268	1260	1252	1241
		TEMP RISE	58	58	59	59	59
		WATTS	162	300	323	361	432
	1370	CFM	1374	1373	1361	1350	1333
		TEMP RISE	54	54	54	55	55
		WATTS	202	357	375	411	485
	1540	CFM	1540	1536	1518	1500	1476
		TEMP RISE	48	48	49	49	50
		WATTS	278	459	464	492	567

*DD2C100ACV52B Furnace Cooling Airflow (CFM) and Power (Watts) vs. External Static Pressure with Filter							
OD	AIRFLOW		0.1	0.3	0.5	0.7	0.9
3.0	290	CFM	888	890	887	879	866
		WATTS	90	134	175	217	260
	350	CFM	1066	1065	1058	1052	1042
		WATTS	137	184	229	277	325
	400	CFM	1193	1196	1187	1182	1173
		WATTS	183	236	287	338	393
	450	CFM	1346	1349	1339	1334	1323
		WATTS	240	297	353	409	465
3.5	290	CFM	1035	1042	1031	1025	1015
		WATTS	123	172	217	264	311
	350	CFM	1212	1210	1207	1197	1187
		WATTS	190	242	294	346	399
	400	CFM	1403	1404	1396	1384	1378
		WATTS	256	319	378	432	492
	450	CFM	1573	1578	1566	1555	1542
		WATTS	358	427	486	550	612
4.0	290	CFM	1169	1166	1160	1153	1144
		WATTS	170	219	269	320	371
	350	CFM	1403	1404	1396	1384	1378
		WATTS	256	319	378	432	492
	400	CFM	1593	1597	1593	1583	1573
		WATTS	369	439	505	573	636
	450	CFM	1806	1805	1800	1795	1764
		WATTS	511	586	662	735	787
5.0	290	CFM	1454	1448	1438	1434	1413
		WATTS	292	351	409	469	522
	350	CFM	1765	1778	1734	1726	1717
		WATTS	488	575	612	685	760
	400	CFM	2011	2006	1988	1951	1891
		WATTS	697	779	848	900	920
	450	CFM	2212	2159	2081	1998	1917
		WATTS	912	956	953	951	947

NOTES:

- \*FIRST LETTER MAY BE "A" OR "T"
- \*\*FACTORY SETTING
- CONTINUOUS FAN SPEED SETTING: HEATING OR COOLING AIRFLOW IS APPROXIMATELY 50% OF SELECTED COOLING VALUE.
- WITH VARIABLE SPEED OUTDOOR UNIT APPLICATION, THE LOW SPEED AIRFLOWS ARE APPROXIMATELY 30% OF LISTED VALUES.
- LOW 350 CFM/TON IS RECOMMENDED FOR VARIABLE SPEED APPLICATIONS FOR COMFORT & HUMID CLIMATE SETTING: NORMAL IS 400 CFM/TON: HIGH 450 CFM/TON IS FOR DRY CLIMATE SETTING.
- CONTINUOUS FAN MODE DURING COOLING OPERATION MAY NOT BE APPROPRIATE IN HUMID CLIMATES. IF THE INDOOR AIR EXCEEDS 60% RELATIVE HUMIDITY OR SIMPLY FEELS UNCOMFORTABLY HUMID, IT IS RECOMMENDED THAT THE FAN ONLY BE USED IN THE AUTO MODE.

# Performance Data



*DD2D120ACV52B Furnace Heating Airflow (CFM) and Power (Watts) vs. External Static Pressure							
			0.1	0.3	0.5	0.7	0.9
HEATING 1ST STAGE	1040	CFM	1041	1045	1040	1010	1042
		TEMP RISE	55	55	55	57	55
		WATTS	128	173	196	231	269
	1183	CFM	1178	1181	1176	1147	1170
		TEMP RISE	49	49	49	50	49
		WATTS	169	218	241	284	334
	1300	CFM	1290	1292	1286	1259	1275
		TEMP RISE	45	45	45	46	45
		WATTS	211	264	286	333	390
HEATING 2ND STAGE	1600	CFM	1578	1578	1570	1547	1543
		TEMP RISE	56	56	56	57	57
		WATTS	352	414	433	482	543
	1820	CFM	1789	1788	1778	1757	1739
		TEMP RISE	49	49	50	50	51
		WATTS	487	555	568	613	665
	2000	CFM	1962	1959	1949	1930	1900
		TEMP RISE	45	45	45	46	47
		WATTS	618	690	697	734	771

*DD2D120ACV52B Furnace Cooling Airflow (CFM) and Power (Watts) vs. External Static Pressure with Filter							
OD	AIRFLOW		0.1	0.3	0.5	0.7	0.9
3.5	290	CFM	1013	1020	1014	1004	993
		WATTS	100	153	192	238	283
	350	CFM	1216	1208	1210	1201	1187
		WATTS	155	213	259	304	358
	400	CFM	1380	1385	1377	1367	1362
		WATTS	217	287	339	387	439
450	CFM	1557	1561	1556	1544	1539	
	WATTS	312	377	434	490	550	
4.0	290	CFM	1155	1158	1148	1000	1131
		WATTS	149	193	236	322	336
	350	CFM	1380	1385	1377	1367	1362
		WATTS	217	287	339	387	439
	400	CFM	1579	1583	1580	1570	1559
		WATTS	310	388	447	507	564
450	CFM	1788	1783	1759	1774	1769	
	WATTS	437	522	661	659	728	
5.0	290	CFM	1430	1431	1424	1416	1406
		WATTS	247	311	363	415	468
	350	CFM	1730	1732	1728	1719	1714
		WATTS	398	487	552	618	682
	400	CFM	1980	1973	1967	1963	1966
		WATTS	586	676	750	832	922
450	CFM	2175	2172	2157	2082	2009	
	WATTS	777	886	959	962	968	

**NOTES:**

1. \*FIRST LETTER MAY BE "A" OR "T"
2. \*\*FACTORY SETTING
3. CONTINUOUS FAN SPEED SETTING: HEATING OR COOLING AIRFLOW IS APPROXIMATELY 50% OF SELECTED COOLING VALUE.
4. WITH VARIABLE SPEED OUTDOOR UNIT APPLICATION, THE LOW SPEED AIRFLOWS ARE APPROXIMATELY 30% OF LISTED VALUES.
5. LOW 350 CFM/TON IS RECOMMENDED FOR VARIABLE SPEED APPLICATIONS FOR COMFORT & HUMID CLIMATE SETTING: NORMAL IS 400 CFM/TON: HIGH 450 CFM/TON IS FOR DRY CLIMATE SETTING.
6. CONTINUOUS FAN MODE DURING COOLING OPERATION MAY NOT BE APPROPRIATE IN HUMID CLIMATES. IF THE INDOOR AIR EXCEEDS 60% RELATIVE HUMIDITY OR SIMPLY FEELS UNCOMFORTABLY HUMID, IT IS RECOMMENDED THAT THE FAN ONLY BE USED IN THE AUTO MODE.



# Electrical Data

## Wiring Diagram

**IMPORTANT:**  
INTEGRATED CONTROL IS POLARITY SENSITIVE.  
HOT LEG OF 120V POWER SUPPLY MUST BE  
CONNECTED TO THE BLACK POWER LEAD AS  
INDICATED ON WIRING DIAGRAM.

TABLE "A"	
MODELS	
•UD2B060ACV32^^	•UD2B100ACV32^^
•UD2B080ACV32^^	•UD2C100ACV52^^
•UD2C080ACV42^^	•UD2D120ACV52^^
	•UD2D140ACV52^^
• PREFIX MAY BE "A" OR "T" / ^^ SUFFIX MAY BE AA THROUGH ZZ	

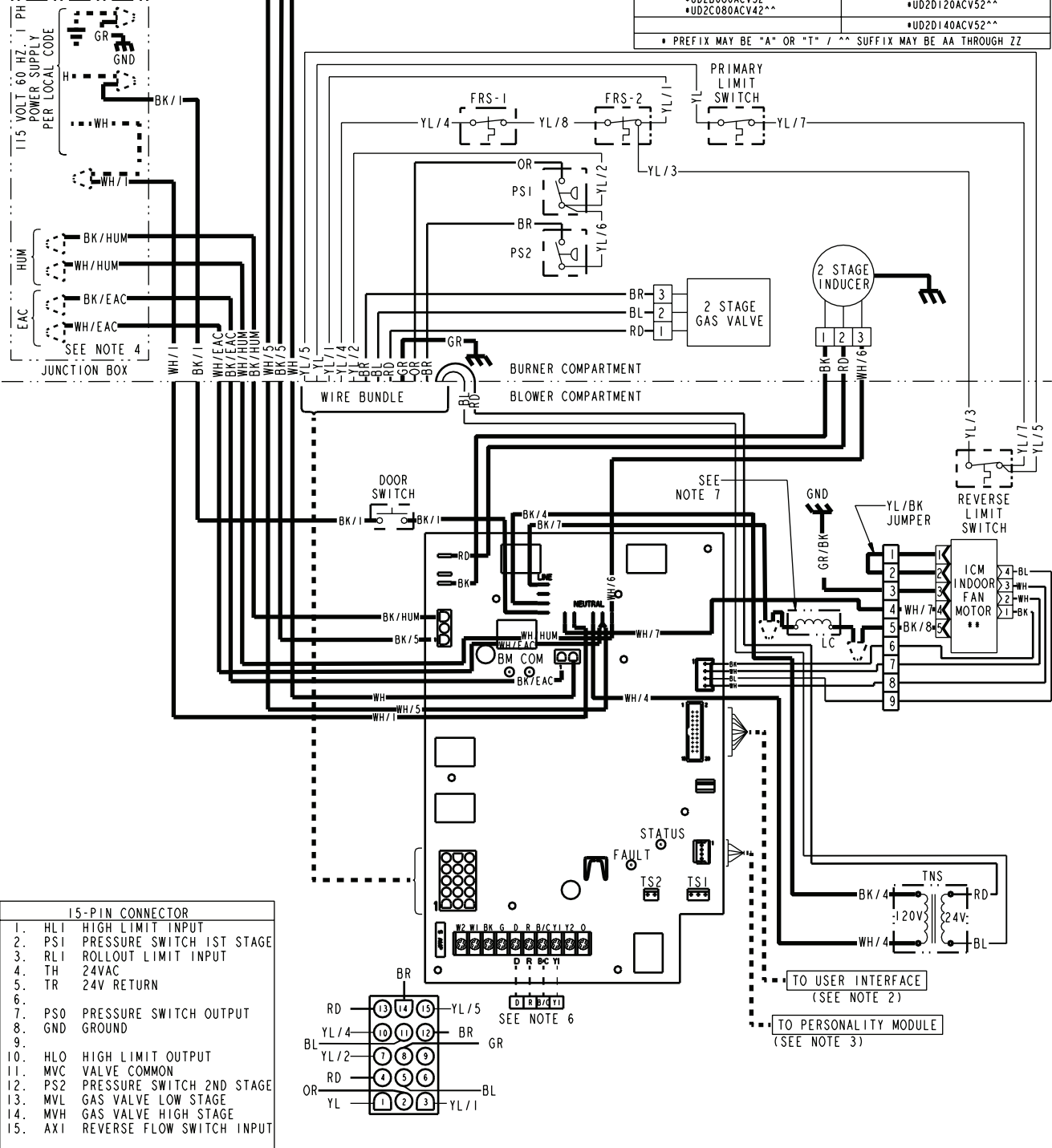

15-PIN CONNECTOR	
1.	HLI HIGH LIMIT INPUT
2.	PS1 PRESSURE SWITCH 1ST STAGE
3.	RL1 ROLLOUT LIMIT INPUT
4.	TH 24VAC
5.	TR 24V RETURN
6.	
7.	PS0 PRESSURE SWITCH OUTPUT
8.	GND GROUND
9.	
10.	HLO HIGH LIMIT OUTPUT
11.	MVC VALVE COMMON
12.	PS2 PRESSURE SWITCH 2ND STAGE
13.	MVL GAS VALVE LOW STAGE
14.	MVH GAS VALVE HIGH STAGE
15.	AXI REVERSE FLOW SWITCH INPUT

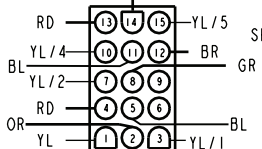

### ⚠ CAUTION

Label all wires prior to disconnection when servicing controls.  
Wiring errors can cause improper and dangerous operation.  
Verify proper operation after servicing.

(continued on next page)

# Electrical Data



## Schematic Diagram

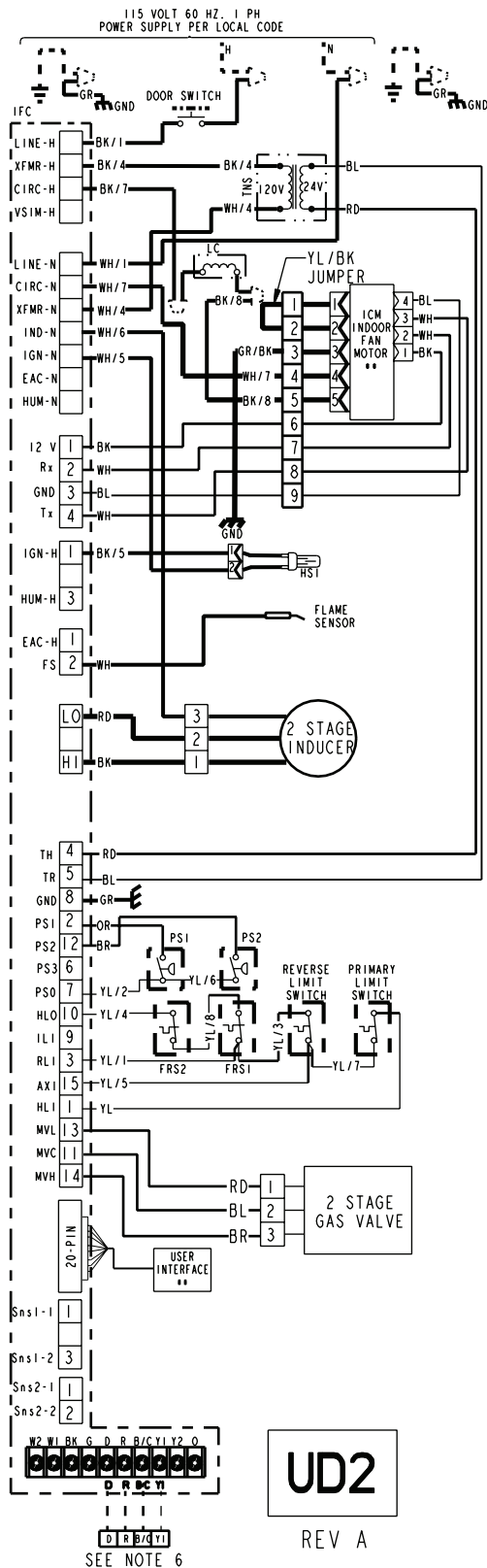

### DIAGNOSTIC CODES

RED LED - FAULT Data - 1 Flash every 20 seconds	
2 FLASHES - SYSTEM LOCKOUT RETRIES OR RECYCLES EXCEEDED	6 FLASHES - 115 VOLT AC POWER REVERSED OR IGNITER FAULT
3 FLASHES - PRESSURE SWITCH FAULT	7 FLASHES - GAS VALVE CIRCUIT ERROR
4 FLASHES - OPEN LIMIT SWITCH	8 FLASHES - LOW FLAME SENSE SIGNAL
5 FLASHES - FLAME SENSED WHEN NO FLAME SHOULD BE PRESENT	9 FLASHES - OPEN INDUCER LIMIT
	10 FLASHES - COMMUNICATION FAULT
	CONTINUOUS ON - INTERNAL CONTROL FAILURE
GREEN LED - STATUS	
SLOW FLASH - NORMAL, NO CALL FOR HEAT	
FAST FLASH - NORMAL, CALL FOR HEAT PRESENT	
GREEN AND RED LED'S ON CONTINUOUS - INTERNAL CONTROL FAILURE	
GREEN AND RED LED'S OFF CONTINUOUS - FUSE OPEN	

### WARNING

HAZARDOUS VOLTAGE

DISCONNECT ALL ELECTRICAL POWER INCLUDING REMOTE DISCONNECTS BEFORE SERVICING.

FAILURE TO DISCONNECT POWER BEFORE SERVICING CAN CAUSE SEVERE PERSONAL INJURY OR DEATH.

### CAUTION

USE COPPER CONDUCTORS ONLY!

UNIT TERMINALS ARE NOT DESIGNED TO ACCEPT OTHER TYPES OF CONDUCTORS.

FAILURE TO DO SO MAY CAUSE DAMAGE TO THE EQUIPMENT.

### INTEGRATED FURNACE CONTROL

REPLACE WITH PART CNT 07081 OR EQUIVALENT

ELECTRICAL RATING  
INPUT: 25 V.A.C., 60 HZ.  
XFMR SEC. CURRENT: 450 MA. + MV LOAD  
MV OUTPUT: 1.5 A @ 24 V.A.C.  
IND OUTPUT: 3 PHASE OUTPUT  
IGN OUTPUT: 2.0 A @ 120V.A.C.  
CIRC. BLOWER OUTPUT: 14.5 FLA,  
25 LRA @ 120 VAC  
HUMIDIFIER & AIR CLEANER  
MAX. LOAD: 1.0 A @ 120 VAC

TIMINGS  
PREPURGE: 0 SEC.; INTERPURGE: 60 SEC.  
POST PURGE: 5 SECONDS  
IGNITOR WARMUP: 20 SECONDS  
IAP: 3; TFI: 5 SECONDS  
RETRIES: 2; RECYCLES: 10  
HEAT ON DELAY: 45 SECONDS  
COOL ON DELAY: 0 SECONDS  
AUTO RESTART: 60 MINUTES  
AUTO RESTART PURGE: 15 SECONDS

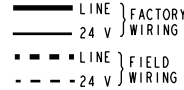
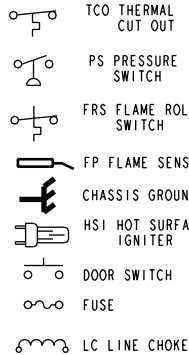

BK BLACK	GR GREEN
WH WHITE	BR BROWN
YL YELLOW	RD RED
OR ORANGE	BL BLUE

•• INTERNAL THERMAL PROTECTION

WIRE COLOR

BK/1 NUMBER ID (IF ANY)

L LINE	TH 24 VAC (HOT)
N NEUTRAL	TR 24 VAC (COMMON)
GND GROUND	MV MAIN GAS VALVE
B/C COMMON	TNS TRANSFORMER
HLO HIGH LIMIT OUTPUT	IL1 INDUCER LIMIT INPUT
HLI HIGH LIMIT INPUT	IFC INTEGRATED FURNACE CONTROL

### NOTES:

- IF ANY OF THE ORIGINAL WIRING AS SUPPLIED WITH THIS FURNACE MUST BE REPLACED, IT MUST BE WITH WIRE HAVING A TEMPERATURE RATING OF AT LEAST 105 C.
- USER INTERFACE MUST BE INSTALLED FOR PROPER FURNACE INSTALLATION & SET-UP.
- CORRECT PERSONALITY MODULE IS REQUIRED FOR PROPER FURNACE OPERATION. PERSONALITY MODULE IS SPECIFIC TO EACH MODEL & SERIAL NUMBER, AND IS TO REMAIN WITHIN IT'S ORIGINAL UNIT.
- THESE LEADS PROVIDE 120V POWER CONNECTIONS FOR ELECTRONIC AIR CLEANER (EAC) AND HUMIDIFIER (HUM). MAX. LOAD: 1.0 AMPS EACH.
- ON POWER-UP, LAST FOUR FAULTS, IF ANY, WILL BE FLASHED ON RED LED. GREEN LED WILL BE SOLID ON DURING LAST FAULT RECOVERY.
- YL IS AN OUTPUT ONLY WHEN USED WITH A NON-COMMUNICATING, A/C ONLY, OUTDOOR UNIT.
- LINE CHOKE (LC) NOT USED ON ALL MODELS.
- IN 24 VOLT MODE, AN OPTIONAL HUMIDISTAT CAN BE CONNECTED BETWEEN THE "R" AND "BK" TERMINALS. FACTORY INSTALLED "BK JUMPER" ON THE CIRCUIT BOARD MUST BE CUT. SEE FURNACE INSTALLERS GUIDE FOR DETAILS.

From Dwg. D343534P01

### CAUTION

Label all wires prior to disconnection when servicing controls. Wiring errors can cause improper and dangerous operation. Verify proper operation after servicing.

# Electrical Data

## Wiring Diagram

15-PIN CONNECTOR		
1.	HLI	HIGH LIMIT INPUT
2.	PSI	PRESSURE SWITCH 1ST STAGE
3.	RLI	ROLL OUT SWITCH INPUT
4.	TH	24VAC
5.	TR	24V RETURN
6.		
7.	PSO	PRESSURE SWITCH OUTPUT
8.	GND	GROUND
9.		
10.	HLO	LIMIT SWITCH OUTPUT
11.	MVC	VALVE COMMON
12.	PS2	PRESSURE SWITCH 2ND STAGE
13.	MVL	GAS VALVE LOW STAGE
14.	MVH	GAS VALVE HIGH STAGE
15.	AXI	REVERSE FLOW SWITCH INPUT

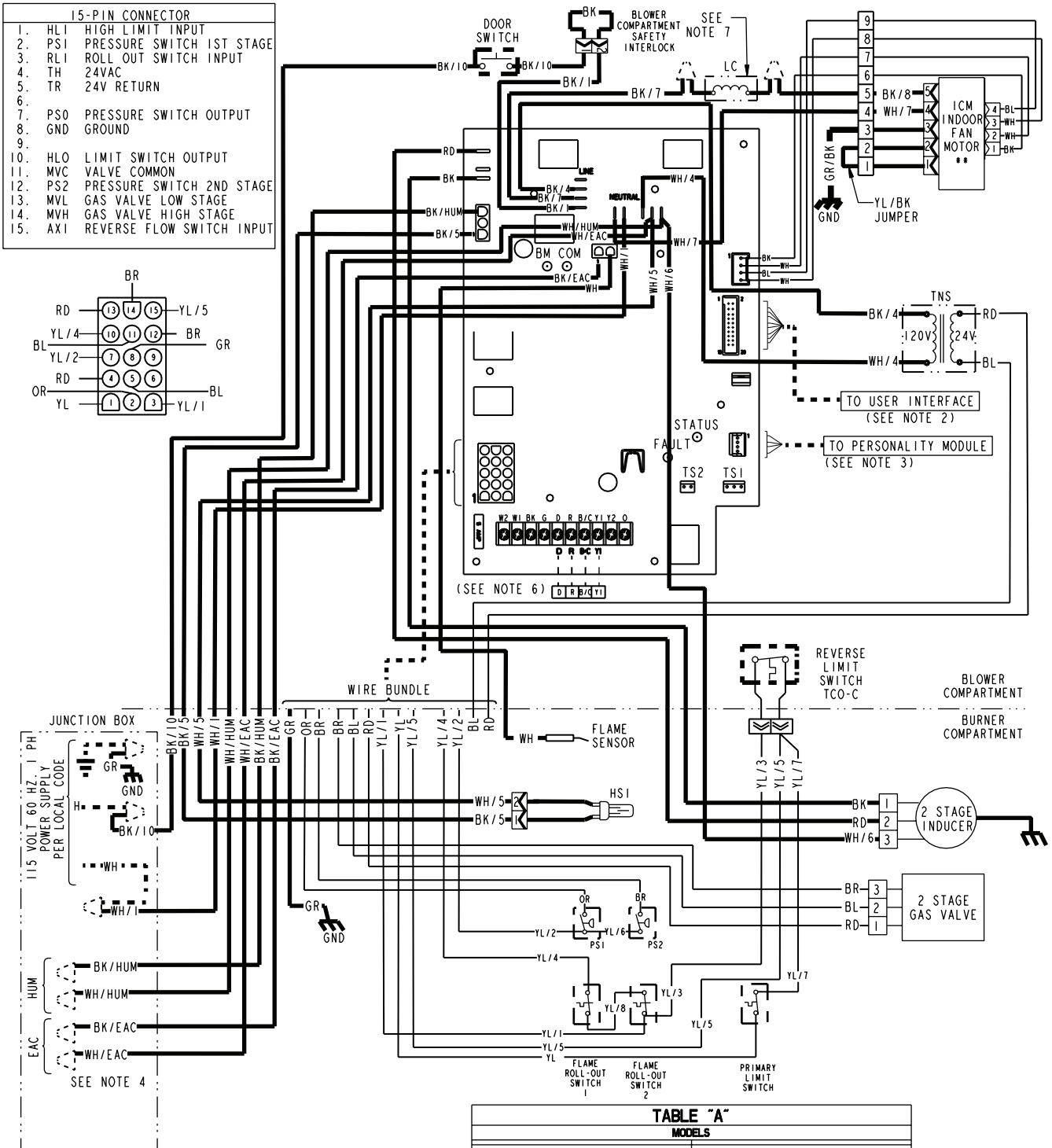
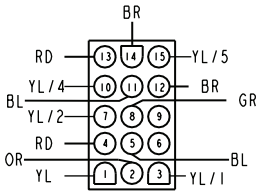

**IMPORTANT:**  
 INTEGRATED CONTROL IS POLARITY SENSITIVE.  
 HOT LEG OF 120V POWER SUPPLY MUST BE CONNECTED  
 TO THE BLACK POWER LEAD AS INDICATED ON WIRING DIAGRAM.

TABLE "A"	
MODELS	
*DD2B060ACV32^^	*DD2C100ACV52^^
*DD2B080ACV32^^	*DD2D120ACV52^^
* PREFIX MAY BE "A" OR "T" / ^^ SUFFIX MAY BE AA THROUGH ZZ	

**CAUTION**  
 Label all wires prior to disconnection when servicing controls.  
 Wiring errors can cause improper and dangerous operation.  
 Verify proper operation after servicing.

From Dwg. D343535P01  
 (continued on next page)

# Electrical Data



## Schematic Diagram

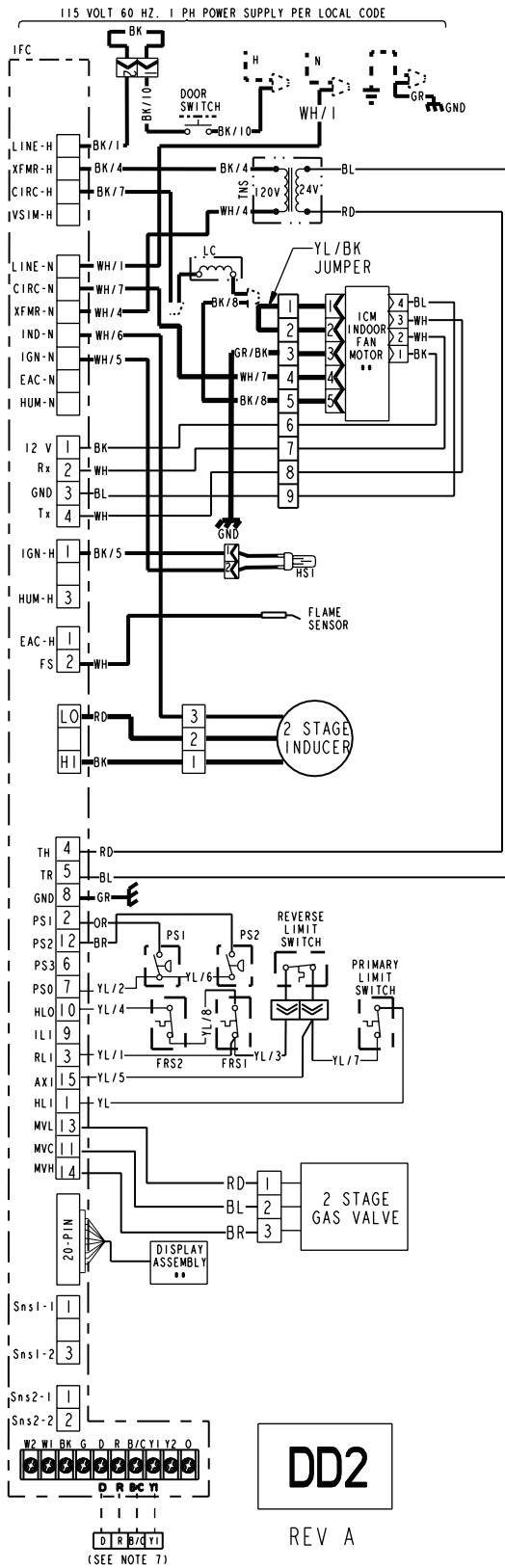

DIAGNOSTIC CODES	
RED LED - FAULT Data - 1 Flash every 20 seconds	
2 FLASHES - SYSTEM LOCKOUT RETRIES OR RECYCLES EXCEEDED	6 FLASHES - 115 VOLT AC POWER REVERSED OR IGNITER FAULT
3 FLASHES - PRESSURE SWITCH FAULT	7 FLASHES - GAS VALVE CIRCUIT ERROR
4 FLASHES - OPEN LIMIT SWITCH	8 FLASHES - LOW FLAME SENSE SIGNAL
5 FLASHES - FLAME SENSED WHEN NO FLAME SHOULD BE PRESENT	9 FLASHES - OPEN INDUCER LIMIT
	10 FLASHES - COMMUNICATION FAULT
	CONTINUOUS ON - INTERNAL CONTROL FAILURE
GREEN LED - STATUS	
SLOW FLASH - NORMAL, NO CALL FOR HEAT	
FAST FLASH - NORMAL, CALL FOR HEAT PRESENT	
GREEN AND RED LED'S ON CONTINUOUS - INTERNAL CONTROL FAILURE	
GREEN AND RED LED'S OFF CONTINUOUS - FUSE OPEN	

WARNING	CAUTION
HAZARDOUS VOLTAGE  DISCONNECT ALL ELECTRICAL POWER INCLUDING REMOTE DISCONNECTS BEFORE SERVICING.  FAILURE TO DISCONNECT POWER BEFORE SERVICING CAN CAUSE SEVERE PERSONAL INJURY OR DEATH.	USE COPPER CONDUCTORS ONLY!  UNIT TERMINALS ARE NOT DESIGNED TO ACCEPT OTHER TYPES OF CONDUCTORS.  FAILURE TO DO SO MAY CAUSE DAMAGE TO THE EQUIPMENT.

**INTEGRATED FURNACE CONTROL**

REPLACE WITH PART CNT 07081 OR EQUIVALENT  
ELECTRICAL RATING  
INPUT: 25 V.A.C., 60 HZ.  
XFMR SEC. CURRENT: 450 MA. + MV LOAD  
MV OUTPUT: 1.5 A @ 24 V.A.C.  
IND OUTPUT: 3 PHASE OUTPUT  
IGN OUTPUT: 2.0 A @ 120V.A.C.  
CIRC. BLOWER OUTPUT: 14.5 FLA,  
25 LRA @ 120 VAC  
HUMIDIFIER & AIR CLEANER  
MAX. LOAD: 1.0 A @ 120 VAC

**TIMINGS**  
PREPURGE: 0 SEC.; INTERPURGE: 60 SEC.  
POST PURGE: 5 SECONDS  
IGNITOR WARMUP: 20 SECONDS  
IAP: 3; TFI: 5 SECONDS  
RETRIES: 2; RECYCLES: 10  
HEAT ON DELAY: 45 SECONDS  
COOL ON DELAY: 0 SECONDS  
AUTO RESTART: 60 MINUTES  
AUTO RESTART PURGE: 15 SECONDS

TCO THERMAL CUT OUT	PS PRESSURE SWITCH	FRS FLAME ROLLOUT SWITCH	FP FLAME SENSOR	CHASSIS GROUND	HSI HOT SURFACE IGNITER	DOOR SWITCH	FUSE	LC LINE CHOKE
CF CAPACITOR	COIL							

**WIRING**  
 — LINE  
 — 24 V  
 - - - LINE  
 - - - 24 V

BK	BLACK	GR	GREEN
WH	WHITE	BR	BROWN
YL	YELLOW	RD	RED
OR	ORANGE	BL	BLUE

**WIRE COLOR**  
 BK/1 — NUMBER ID (IF ANY)

L	LINE	TR	24 VAC (HOT)
N	NEUTRAL	TR	24 VAC (COMMON)
GND	GROUND	MV	MAIN GAS VALVE
B/C	COMMON	TNS	TRANSFORMER
HLO	HIGH LIMIT OUTPUT	ILI	INDUCER LIMIT INPUT
HLI	HIGH LIMIT INPUT	IFC	INTEGRATED FURNACE CONTROL

- NOTES:**
- IF ANY OF THE ORIGINAL WIRING AS SUPPLIED WITH THIS FURNACE MUST BE REPLACED, IT MUST BE WITH WIRE HAVING A TEMPERATURE RATING OF AT LEAST 105 C.
  - USER INTERFACE MUST BE INSTALLED FOR PROPER FURNACE INSTALLATION & SET-UP.
  - CORRECT PERSONALITY MODULE IS REQUIRED FOR PROPER FURNACE OPERATION. PERSONALITY MODULE IS SPECIFIC TO EACH MODEL & SERIAL NUMBER, AND IS TO REMAIN WITHIN IT'S ORIGINAL UNIT.
  - THESE LEADS PROVIDE 120V POWER CONNECTIONS FOR ELECTRONIC AIR CLEANER (EAC) AND HUMIDIFIER (HUM). MAX. LOAD: 1.0 AMPS EACH.
  - ON POWER-UP, LAST FOUR FAULTS, IF ANY, WILL BE FLASHED ON RED LED. GREEN LED WILL BE SOLID ON DURING LAST FAULT RECOVERY.
  - Y1 IS AN OUTPUT ONLY WHEN USED WITH A NON-COMMUNICATING, A/C ONLY, OUTDOOR UNIT.
  - LINE CHOKE (LC) NOT USED ON ALL MODELS.
  - IN 24 VOLT MODE, AN OPTIONAL HUMIDISTAT CAN BE CONNECTED BETWEEN THE "R" AND "BK" TERMINALS. FACTORY INSTALLED "BK JUMPER" ON THE CIRCUIT BOARD MUST BE CUT. SEE FURNACE INSTALLERS GUIDE FOR DETAILS.

**DD2**  
REV A

From Dwg. D343535P01

**CAUTION**

Label all wires prior to disconnection when servicing controls. Wiring errors can cause improper and dangerous operation. Verify proper operation after servicing.

# Field Wiring

## Communicating Indoor Unit with Communicating Comfort Control and Communicating Outdoor Unit

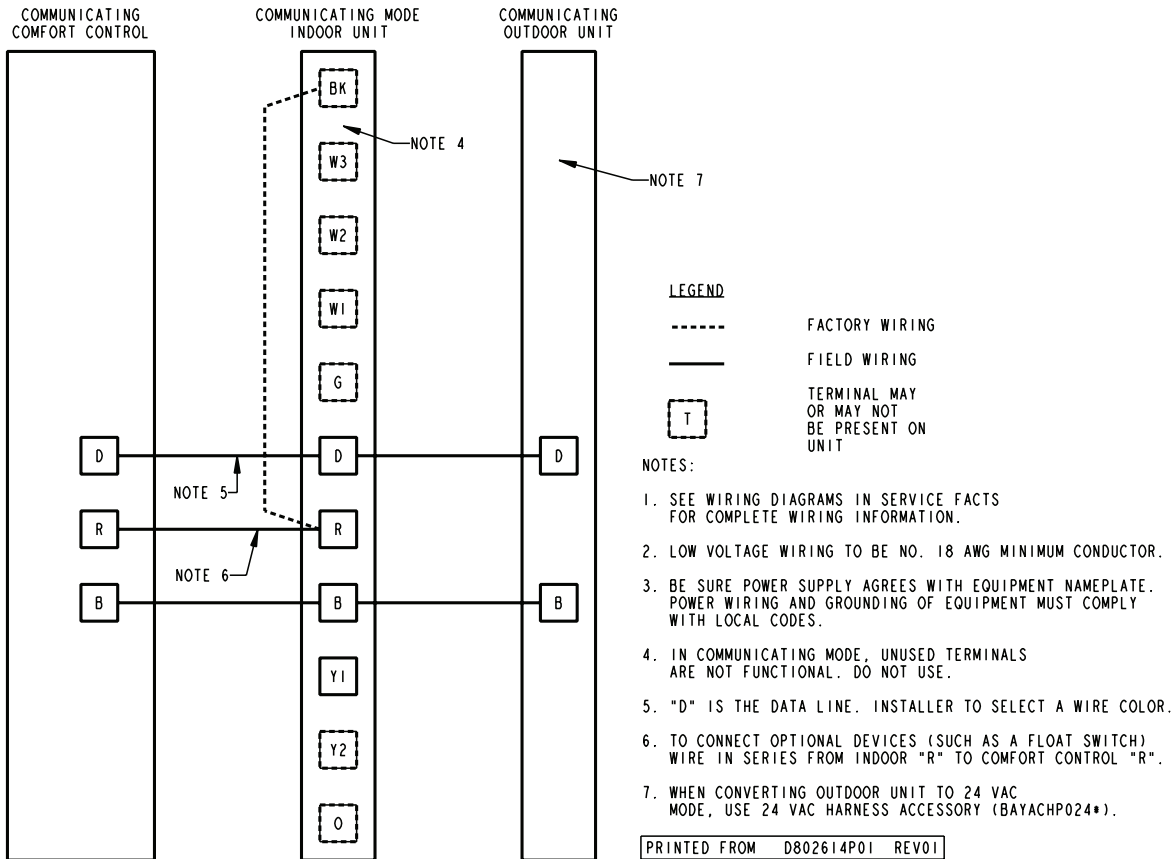

# Communicating Indoor Unit with Communicating Comfort Control and 24VAC Single Stage Cooling

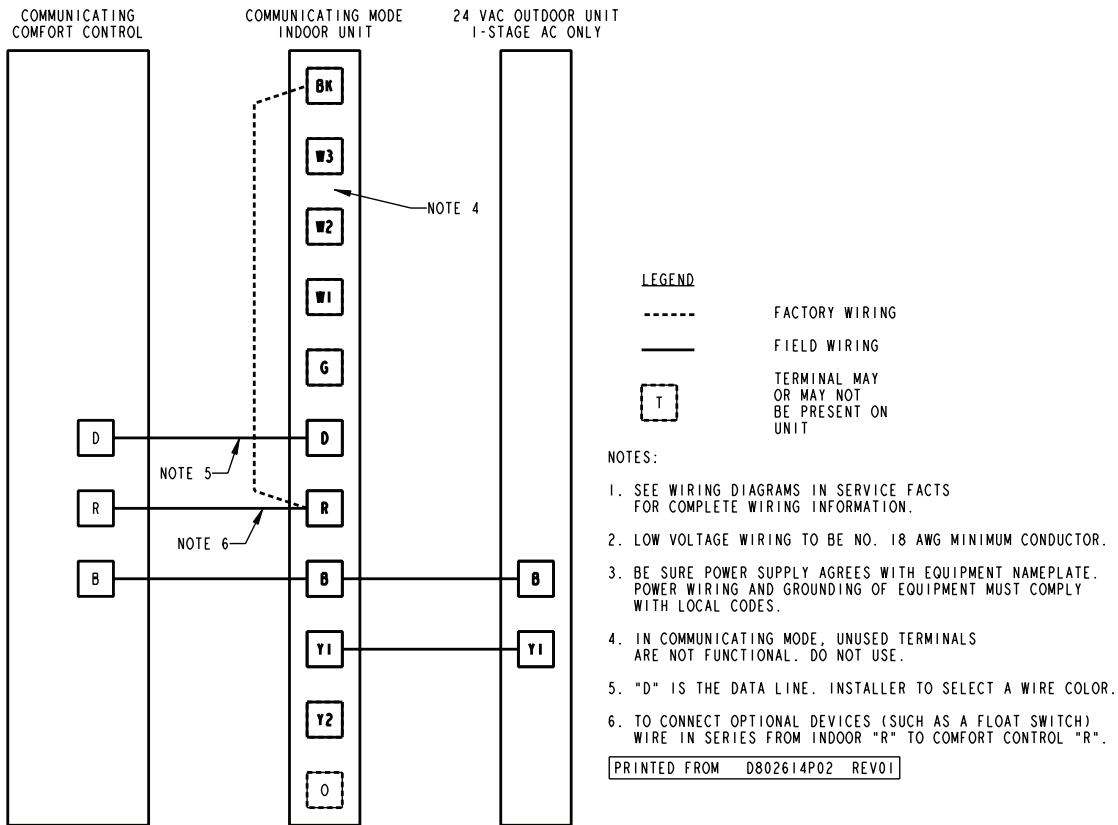

# 24VAC Mode Indoor Unit with 24VAC Comfort Control and 24VAC Single Stage Cooling

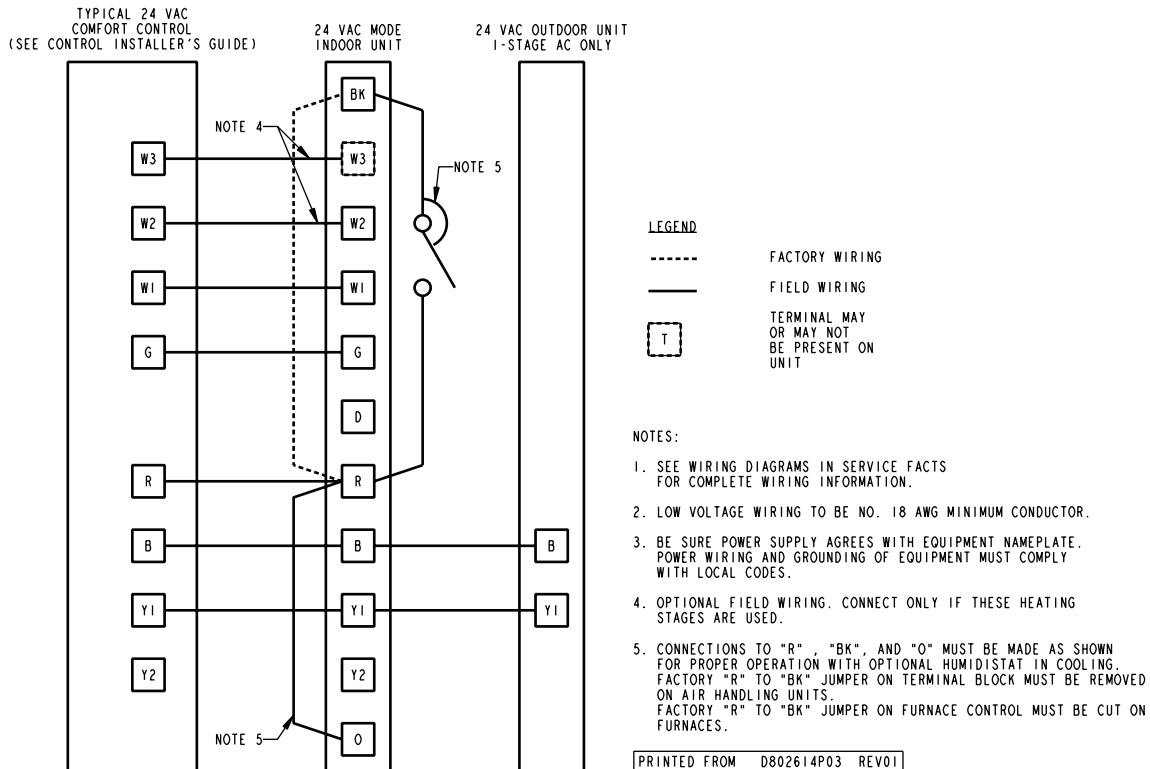

**NOTE:**

To locate the BK to R jumper on the IFC board, see page 28.

## 24VAC Mode Indoor Unit with 24VAC Comfort Control and 24VAC 2-Stage or 2-Step Cooling

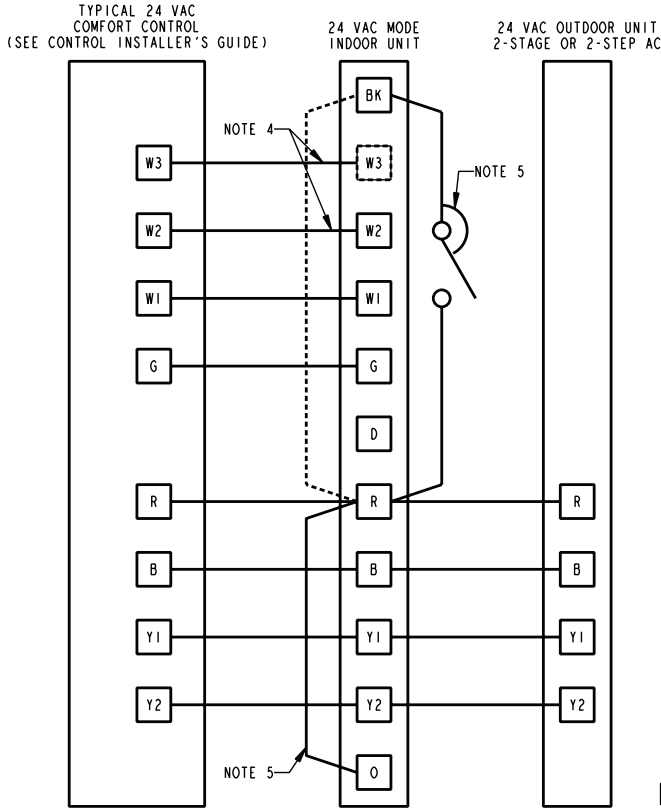

### LEGEND

- FACTORY WIRING
- FIELD WIRING
- [ T ] TERMINAL MAY OR MAY NOT BE PRESENT ON UNIT

### NOTES:

1. SEE WIRING DIAGRAMS IN SERVICE FACTS FOR COMPLETE WIRING INFORMATION.
2. LOW VOLTAGE WIRING TO BE NO. 18 AWG MINIMUM CONDUCTOR.
3. BE SURE POWER SUPPLY AGREES WITH EQUIPMENT NAMEPLATE. POWER WIRING AND GROUNDING OF EQUIPMENT MUST COMPLY WITH LOCAL CODES.
4. OPTIONAL FIELD WIRING. CONNECT ONLY IF THESE HEATING STAGES ARE USED.
5. CONNECTIONS TO "R", "BK", AND "O" MUST BE MADE AS SHOWN FOR PROPER OPERATION WITH OPTIONAL HUMIDISTAT IN COOLING. FACTORY "R" TO "BK" JUMPER ON TERMINAL BLOCK MUST BE REMOVED ON AIR HANDLING UNITS. FACTORY "R" TO "BK" JUMPER ON FURNACE CONTROL MUST BE CUT ON FURNACES.
6. SEE USER INTERFACE 24 VAC MODE SETUP MENU FOR 1ST STAGE CFM OPTIONS.  
2-STAGE = 39-64%  
2-STEP = 65-80%

PRINTED FROM D802614P04 REV01

### NOTE:

To locate the BK to R jumper on the IFC board, see page 28.

## 24VAC Mode Indoor Unit with 24VAC Comfort Control and 24VAC Single Stage Heat Pump

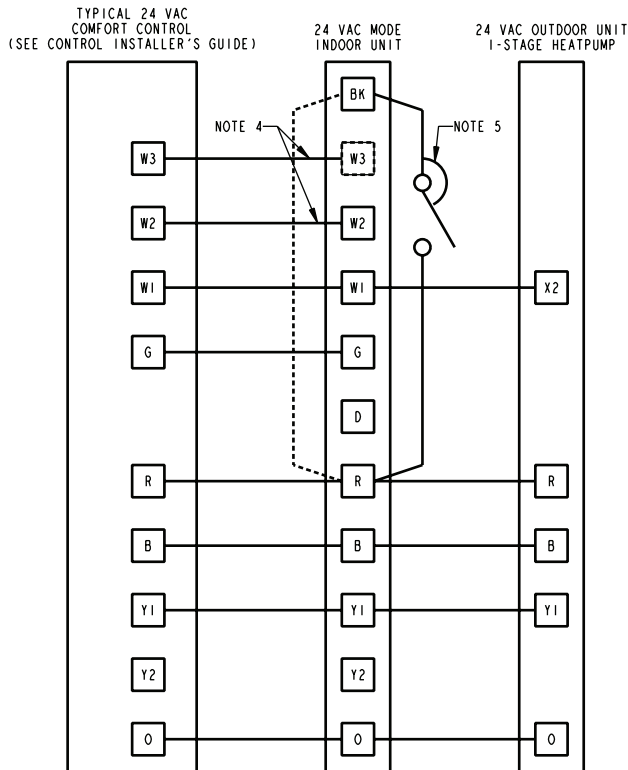

### LEGEND

- FACTORY WIRING
- FIELD WIRING
- [ T ] TERMINAL MAY OR MAY NOT BE PRESENT ON UNIT

### NOTES:

1. SEE WIRING DIAGRAMS IN SERVICE FACTS FOR COMPLETE WIRING INFORMATION.
2. LOW VOLTAGE WIRING TO BE NO. 18 AWG MINIMUM CONDUCTOR.
3. BE SURE POWER SUPPLY AGREES WITH EQUIPMENT NAMEPLATE. POWER WIRING AND GROUNDING OF EQUIPMENT MUST COMPLY WITH LOCAL CODES.
4. OPTIONAL FIELD WIRING. CONNECT ONLY IF THESE HEATING STAGES ARE USED.
5. CONNECTIONS TO "R", "BK", AND "O" MUST BE MADE AS SHOWN FOR PROPER OPERATION WITH OPTIONAL HUMIDISTAT IN COOLING. FACTORY "R" TO "BK" JUMPER ON TERMINAL BLOCK MUST BE REMOVED ON AIR HANDLING UNITS. FACTORY "R" TO "BK" JUMPER ON FURNACE CONTROL MUST BE CUT ON FURNACES.
6. ON FURNACE APPLICATIONS, COMFORT CONTROL MUST BE DUAL FUEL COMPATIBLE (SEE CONTROL INSTALLER'S GUIDE) OR MUST USE TAYPLUS103.

PRINTED FROM D802614P05 REV01

### NOTE:

To locate the BK to R jumper on the IFC board, see page 28.

# 24VAC Mode Indoor Unit with 24VAC Comfort Control and 24VAC 2-Stage or 2-Step Heat Pump

TYPICAL 24 VAC COMFORT CONTROL (SEE CONTROL INSTALLER'S GUIDE)      24 VAC MODE INDOOR UNIT      24 VAC OUTDOOR UNIT 2-STAGE OR 2-STEP HP

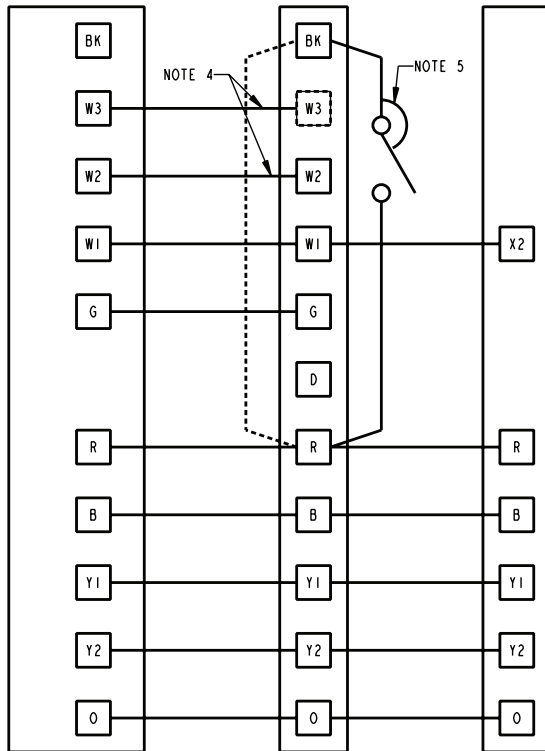

### LEGEND

- FACTORY WIRING
- FIELD WIRING
- T TERMINAL MAY OR MAY NOT BE PRESENT ON UNIT

### NOTES:

1. SEE WIRING DIAGRAMS IN SERVICE FACTS FOR COMPLETE WIRING INFORMATION.
2. LOW VOLTAGE WIRING TO BE NO. 18 AWG MINIMUM CONDUCTOR.
3. BE SURE POWER SUPPLY AGREES WITH EQUIPMENT NAMEPLATE. POWER WIRING AND GROUNDING OF EQUIPMENT MUST COMPLY WITH LOCAL CODES.
4. OPTIONAL FIELD WIRING. CONNECT ONLY IF THESE HEATING STAGES ARE USED.
5. CONNECTIONS TO "R", "BK", AND "O" MUST BE MADE AS SHOWN FOR PROPER OPERATION WITH OPTIONAL HUMIDISTAT IN COOLING. FACTORY "R" TO "BK" JUMPER ON TERMINAL BLOCK MUST BE REMOVED ON AIR HANDLING UNITS. FACTORY "R" TO "BK" JUMPER ON FURNACE CONTROL MUST BE CUT ON FURNACES.
6. ON FURNACE APPLICATIONS, COMFORT CONTROL MUST BE DUAL FUEL COMPATIBLE (SEE CONTROL INSTALLERS GUIDE) OR MUST USE TAYPLUS103.
7. SEE USER INTERFACE 24 VAC MODE SETUP MENU FOR 1ST STAGE CFM OPTIONS.  
 2-STAGE = 39-64%  
 2-STEP = 65-80%

PRINTED FROM D802614P06 REV01

### NOTE:

To locate the BK to R jumper on the IFC board, see page 28.

## Wiring Notes:

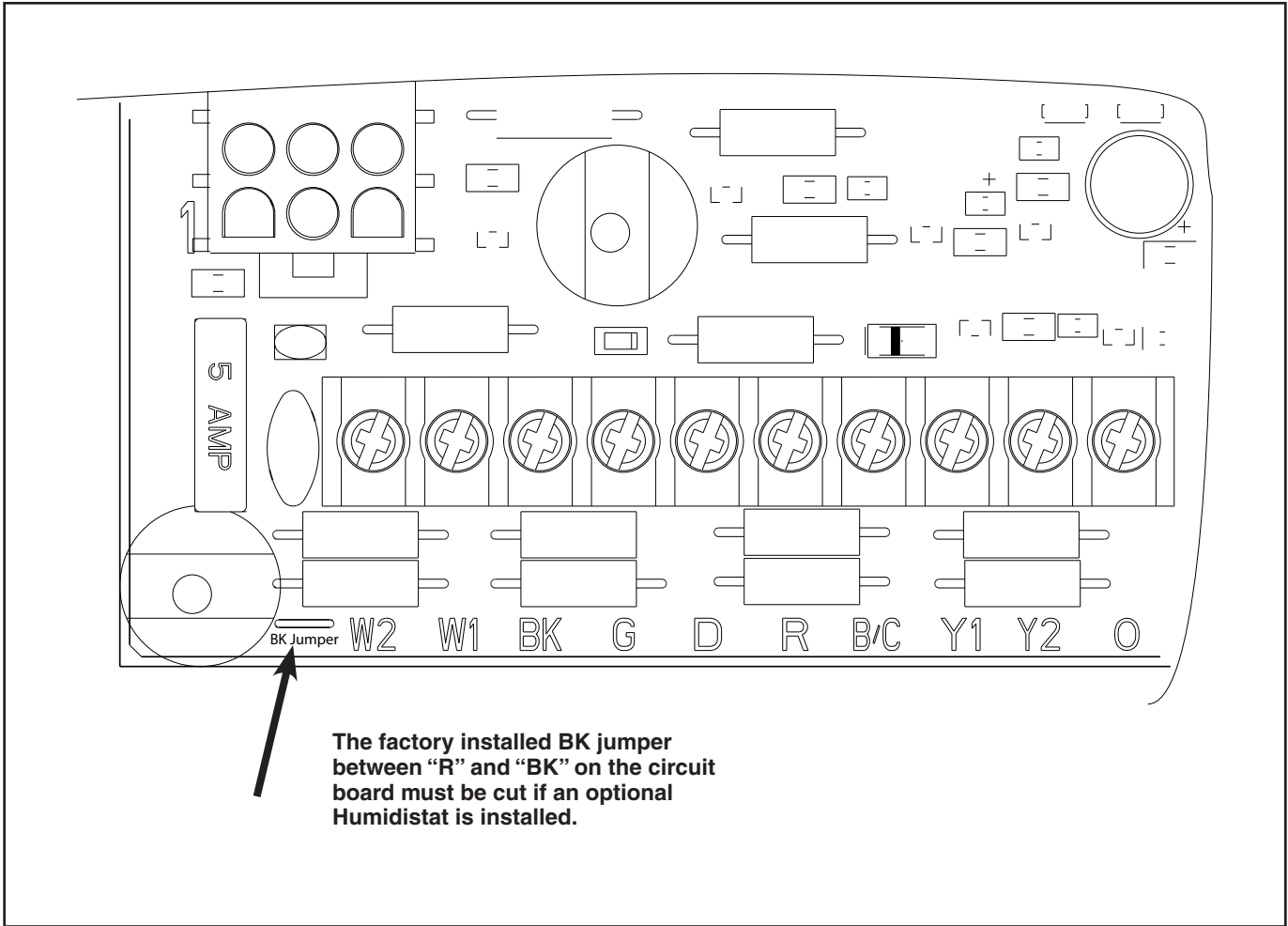

**The factory installed BK jumper between “R” and “BK” on the circuit board must be cut if an optional Humidistat is installed.**

**HUMIDISTAT HOOKUP - 24 V Mode ONLY**

If an optional humidistat for humidity control in cooling is used, the factory installed “BK Jumper” must be cut.

The BK Jumper must also be cut if a multi-zone controller is connected or \*CONT402 is installed and using the BK enabled feature.

See the 24VAC field hookup wiring diagrams for more information.

## \*UD-ACV Outline Drawing

(ALL DIMENSIONS ARE IN INCHES)

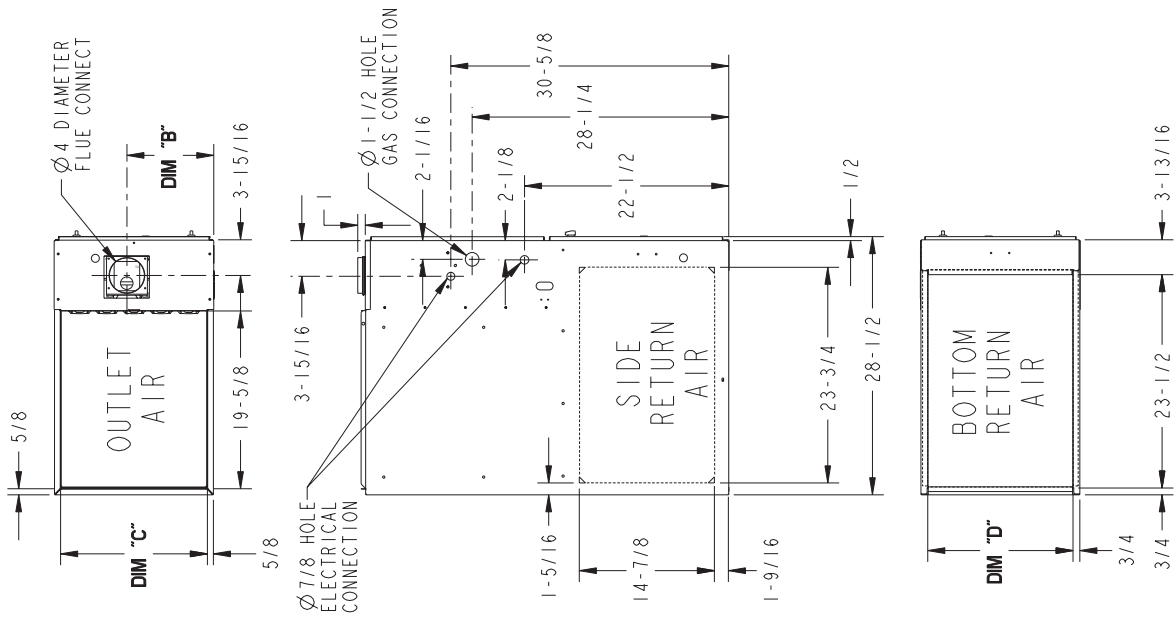

MINIMUM CLEARANCE TO COMBUSTIBLE MATERIALS			
UPFLOW CLOSET			
LEFT SIDE	0 IN.	FRONT	3 IN.
RIGHT SIDE	0 IN.	BACK	0 IN.
FLUE	#6 IN.	TOP	1 IN.
HORIZONTAL CLOSET (SEE NOTE 1)			
TOP	2 IN.	BACK	3 IN.
FLUE	#6 IN.	SIDES	1 IN.
FRONT	18 IN.		
HORIZONTAL ALCOVE (SEE NOTE 1)			
TOP	1 IN.	BACK	0 IN.
FLUE	#6 IN.	SIDES	0 IN.
FRONT	18 IN.		

NOTES:  
 1 - MAY BE 1" WHEN TYPE B-1 VENT IS USED.  
 1 - MAY BE INSTALLED ON COMBUSTIBLE FLOOR WHEN TYPE B-1 VENT IS USED.

MODEL	A	B	C	D
*UD2B060ACV32B	17-1/2"	9-5/8"	16-1/4"	16"
*UD2B080ACV32B	21"	13-1/16"	19-3/4"	19-1/2"
*UD2B100ACV32B	24-1/2"	15-5/16"	23-1/4"	23"

\* - The First Letter May Be "A" or "T"







Trane  
6200 Troup Highway  
Tyler, TX 75707  
[www.trane.com](http://www.trane.com)



The manufacturer has a policy of continuous product improvement and reserves the right to change design and specifications without notice.

© 2016 Trane