



Product Catalog

C-Series

Concealed (Ducted) Indoor and Outdoor Units



Indoor unit model
number: 4MUD*****



Outdoor unit model number: 4TUK*****



Introduction

Trane® C-Series ductless systems offer heating and cooling capacities ranging from 1.5 to 4 tons to precisely meet the requirements of indoor spaces while delivering high energy efficiency—up to 20 SEER. A variety of indoor fan coil unit options are available in both ceiling cassette and concealed designs, so your Trane ductless system can be perfectly tailored to the requirements of the space. Trane C-Series systems support pipe runs of up to 98 vertical ft (29.9 m), and up to 245 total ft (74.7 m). All C-Series systems are rated for cooling operation to 0°F (-17.8°C) and heating operation to -4°F (-20°C).

Suitable for a wide variety of applications, Trane C-Series systems can reliably deliver precise temperature control to maintain comfort, as well as ensure the reliability of heat-generating equipment like computer servers, making them perfect for applications like small remote facilities on larger campuses, data centers, machine rooms and more. Trane C-Series systems are also a perfect supplement to larger Trane VRF systems, with the same controls available to both systems.

Copyright

This document and the information in it are the property of Trane, and may not be used or reproduced in whole or in part without written permission. Trane reserves the right to revise this publication at any time, and to make changes to its content without obligation to notify any person of such revision or change.

Trademarks

All trademarks referenced in this document are the trademarks of their respective owners.

Related Documents

For C-Series Cassette Indoor Unit Systems, refer to MS-PRC019*–EN.



Table of Contents

- Features and Benefits 5
- Mechanical Specification 6
 - Outdoor Unit 6
 - Indoor Unit 6
- Indoor Unit Model Number Description 8
- Outdoor Unit Model Number Descriptions 9
- Controls 10
- Accessories 11
- Product Specification 12
- Capacity Tables 19
- Unit Dimensions 37
 - Indoor Unit Dimensions 37
 - Outdoor Unit Dimensions 39
- Wiring Diagrams 40
 - Indoor Unit 40
 - Outdoor Unit 42
- Sound Levels 44
 - Indoor Unit 44
 - Outdoor Unit 46
- Airflow Diagrams 48
 - How to Interpret P-Q Tables and Graphs 48
 - 4MUD4518A10N0A 49
 - 4MUD4524A10N0A 50
 - 4MUD4530A10N0A 51
 - 4MUD4536A10N0A 52
 - 4MUD4542A10N0A 53
 - 4MUD4548A10N0A 54
- Refrigerant Cycle Diagram 55



Table of Contents

Capacity Correction Tables.....	56
4MUD4518A10N0A and 4TUK4518A10N0A.....	56
4MUD4524A10N0A and 4TUK4524A10N0A	57
4MUD4530A10N0A and 4TUK4530A10N0A	58
4MUD4536A10N0A and 4TUK4536A10N0A	59
4MUD4542A10N0A and 4TUK4542A10N0A	60
4MUD4548A10N0A and 4TUK4548A10N0A	61



Features and Benefits

The following is a list of standard features:

- 10 year parts and compressor warranty
- Low ambient cooling to 0°F (-17.8°C) (with baffle)
- Low ambient heating to -4°F (-20°C)
- Auto restart on power fail
- Factory installed condensate pump
- Night time quiet operation mode
- Return air filter standard
- Inverter compressor/condenser fan motor
- BLDC supply fan
- Low pressure cutoff

The following is a list of optional features:

- Return air filter box with MERV 13 filter
- Low ambient wind baffle
- Wireless remote control
- Wired programmable controller
- Simple touch controller
- Refrigerant line set
- Condenser pad
- Isolation ball valve with access port



Mechanical Specification

Outdoor Unit

This unit is fully charged from the factory for up to 25 ft (7.6 m) of piping. In cooling mode, the system is designed to operate at outdoor ambient temperatures between 23°F and 115°F (-5°C and 46.1°C). With the addition of a wind baffle, cooling capacity is extended down to 0°F (-17.8°C). In heating mode, the system is designed to operate at outdoor ambient temperatures between -4°F (-20°C) and 76°F (24°C). Cooling and heating capacities and efficiencies are AHRI certified. The unit is ETL listed for outdoor application.

Unit Casing

The unit casing is constructed of heavy gauge, galvanized steel and painted with weather-resistant powder paint.

Refrigerant Controls

Refrigeration system controls include condenser fan and compressor relays. Each outdoor unit is completely factory assembled, including a modulating linear expansion valve and suction line multi-function service valve. High and low pressure controls are inherent to the compressor.

Compressor

The compressor has inverter driven technology to modulate capacity. Additional features include internal thermal overload and pressure protection. A total dipping process protects hermetic motor windings. The compressor is mounted to avoid the transmission of vibration and noise.

Condenser Coil

The coil is manufactured with aluminum micro-channel tubing. The coil provides air flow resistance and efficient heat transfer. The coil is protected by the casing and coil guard.

Indoor Unit

Concealed (duct type) air handlers are high-performance ceiling-concealed ducted fan coils with field-adjustable return and a fixed horizontal discharge supply when using field-installed return air filter boxes.. These air handlers are UL 1995 certified to serve multiple rooms.

Each indoor unit is completely factory assembled including control circuit board and fan motor. Each indoor unit includes a condensate drain pan and built-in condensate drain pump. The indoor unit is factory and run tested.

Unit Cabinet

The indoor unit has flanges for ducted, air-supply connections and is UL 1995 certified to serve multiple rooms..

Fan

The indoor fan is statically and dynamically balanced to run on a motor with permanently lubricated bearings. The indoor fan motor has available four speeds: High, Medium, Low, and Auto.

Remote Controller

Wired and wireless control is available for all units (sold separately). Available features include (depending on model):

- On/off control
- Mode selection
- Temperature setpoint
- Fan speed setting
- Dirty filter alert
- Scheduling



Indoor Unit Model Number Description

4	M	U	D	4	5	1	8	A	1	0	N	0	B	A
1	2	3	4	5	6	7	8	9	10	11	12	13	14	15

DIGIT 1 = Refrigerant

4 = R-410a

DIGIT 2 = Product type

M = Mini-split indoor unit

DIGIT 3 = System type

U = C-Series universal match

DIGIT 4 = Configuration type

D = Mid-static pressure duct type

DIGIT 5 = Standard model

4 = Standard model

DIGIT 6 = Connection type

5 = Flare

DIGIT 7,8 = Nominal capacity (Btu/h x 1,000)

18 = 18,000 Btu/h

24 = 24,000 Btu/h

30 = 30,000 Btu/h

36 = 36,000 Btu/h

42 = 42,000 Btu/h

48 = 48,000 Btu/h

DIGIT 9 = Major development sequence

A = First development sequence

B = Second development sequence

DIGIT 10 = Electric power supply characteristics

1 = 208-230/60/1

DIGIT 11 = Reserved for future use

0 = Standard

DIGIT 12 = Miscellaneous digit

N = North America market (mini-split models)

DIGIT 13 = Reserved for future use

0 = Standard

DIGIT 14 = Minor design sequence

A = First design sequence

B = Second design sequence

DIGIT 15 = Service digit (not used for ordering)

A = First sequence

B = Second sequence



Outdoor Unit Model Number Descriptions

4	T	U	K	4	5	1	8	A	1	0	N	0	A
1	2	3	4	5	6	7	8	9	10	11	12	13	14

DIGIT 1 = Refrigerant

4 = R-410A

DIGIT 2 = Product type

T = Mini-split outdoor unit

DIGIT 3 = System type

U = C-Series universal match

DIGIT 4 = Configuration type

K = Heat pump

DIGIT 5 = Family

4 = Standard model

DIGIT 6 = Connection type

5 = Flare

DIGIT 7,8 = Nominal capacity (Btu/h x 1,000)

18 = 18,000 Btu/h

24 = 24,000 Btu/h

30 = 30,000 Btu/h

36 = 36,000 Btu/h

42 = 42,000 Btu/h

48 = 48,000 Btu/h

DIGIT 9 = Major development sequence

A = First development sequence

DIGIT 10 = Electric power supply characteristics

1 = 208-230/60/1

DIGIT 11 = Reserved for future use

0 = Standard

DIGIT 12 = Region of sale

N = North America market (mini-split models)



DIGIT 13 = Reserved for future use

0 = Standard

DIGIT 14 = Minor design sequence

A = First design sequence

Controls

Family	Description		Model Number
Zone Controllers	Wireless Remote Control <ul style="list-style-type: none"> • Mode: Heat/Cool/Auto/Off • Fan: Auto/High/Med/Low • Service Indicator Note: Requires the use of a Duct Signal Receiver.		TVCTRLTRDH00UT
	Simple Touch Control <ul style="list-style-type: none"> • Mode: Heat/Cool/Auto/Off • Fan: Auto/High/med/Low • Service indicator 		TVCTRLTWR0002T
	Wired Remote Control <ul style="list-style-type: none"> • Mode: Heat/Cool/Auto/Off • Fan: Auto/High/Med/Low • Programmable • Service Indicator 		TVCTRLTWRWD01T
	Duct Signal Receiver		TVCTRLTRKA10N0
Centralized Control Systems	VRF Central On/Off Control		TVCTRLTCMA202D
	VRF Touch Screen Control		TVCTRLTCMA300T
Integrated System Management	VRF System Controller		TVCTRLTIMD00A0
	VRF Enterprise Management Software		TVCTRLTSTP3P00
	VRF Power Meter Interface (PIM)		TVCTRLTIMB16A0
Building Management System Gateways	VRF System Controller+BACnet® Note: This controller enables BACnet integration.		TVCTRLTIMB17A0
Interface Modules	VRF External Contact Interface Module/Auxiliary Heat Module		TVCTRLTIMB14A0
Sensors	VRF External Room Temperature Sensor		TVCTRLTRWTA000
Commissioning Utility Kits	VRF Technician Utilities Tool (TUT)		TVCTRLTIMC0300

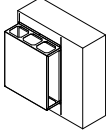
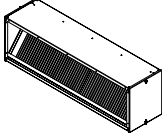

Accessories

Family	Description		Model Number
Ball Valves	1/2 in. Ball Valve Flare		BVALVE12FLARE1
	1/4 in. Ball Valve Flare		BVALVE14FLARE1
	3/8 in. Ball Valve Flare		BVALVE38FLARE1
	5/8 in. Ball Valve Flare		BVALVE58FLARE1
Wind Baffle	18 MBH Outdoor Unit		CSERWINDBFL18AA
	24, 30 MBH Outdoor Unit		CSERWINDBFL24AA
	36, 42, 48 30 MBH Outdoor Unit		CSERWINDBFL36AA
Filter Box	18 & 24 MBH Indoor Unit		MSPDUCTFLTR01AA
	30,36,42,48 MBH Indoor Unit		MSPDUCTFLTR02AA



Product Specification

Table 1. System specifications for 18, 24, and 30 MBH capacity units

System model numbers		4MUD4518A10N0A/ 4TUK4518A10N0A	4MUD4524A10N0A/ 4TUK4524A10N0A	4MUD4530A10N0A/ 4TUK4530A10N0A			
Power supply		208-230/60/1	208-230/60/1	208-230/60/1			
Performance							
		Cooling	Heating	Cooling	Heating	Cooling	Heating
Rated cooling/heating capacity (Btu/h)		18,000	20,000	24,000	27,000	30,000	32,000
Cooling capacity @95°F (Btu/h)	Max	21,000	N/A	27,000	N/A	35,000	N/A
	Min	5,000	N/A	7,000	N/A	9,300	N/A
Heating capacity @47°F (Btu/h)	Max	N/A	25,000	N/A	31,000	N/A	38,000
	Min	N/A	3,800	N/A	5,200	N/A	9,000
Heating capacity @17°F (Btu/h)	Max	N/A	16,500	N/A	23,000	N/A	32,000
	Rated	N/A	13,500	N/A	17,000	N/A	20,600
Heating capacity @5°F (Btu/h)	Max	N/A	14,100	N/A	20,500	N/A	29,000
Heating capacity @-4°F (Btu/h)	Max	N/A	10,000	N/A	14,500	N/A	20,000
SEER/HSPF	Rated per AHRI 210/240	19.6	10.3	20.0	10.5	19.1	10.0
EER @95°F		11.2	11.6	12.1	11.5	11.1	12.0
Dehumidifying volume	pt/hr	4.26		6.13		7.03	
Power							
Rated power input	W	1.61	1.73	1.99	2.35	2.70	2.66
Nominal input current	A	7.4	8.0	9.2	10.8	12.0	12.0

Notes:

- Nominal capacity based on 25 ft (7.6 m) of equivalent refrigerant piping with 0 ft (0 m) level difference.
Cooling: Indoor temperature 80° F DB, 67° F W; outdoor temperature 95° F DB, 75° F WB.
Heating: Indoor temperature 70° F DB, 60° F W; outdoor temperature 47° F DB, 43° F WB.
- Rated per AHRI-210/240 standard conditions.



Product Specification

Table 2. System capacity specifications for 36, 42, and 48 MBH capacity units

System model numbers		4MUD4536A10N0A/ 4TUK4536A10N0A	4MUD4542A10N0A/ 4TUK4542A10N0A	4MUD4548A10N0A/ 4TUK4548A10N0A			
Power supply		208-230/60/1	208-230/60/1	208-230/60/1			
Performance							
		Cooling	Heating	Cooling	Heating	Cooling	Heating
Rated cooling/heating capacity (Btu/h)		36,000	40,000	42,000	47,000	48,000	53,000
Cooling capacity @95°F (Btu/h)	Max	41,000	N/A	45,000	N/A	51,000	N/A
	Min	14,000	N/A	16,300	N/A	18,600	N/A
Heating capacity @47°F (Btu/h)	Max	N/A	48,000	N/A	50,000	N/A	55,000
	Min	N/A	11,500	N/A	13,400	N/A	15,300
Heating capacity @17°F (Btu/h)	Max	N/A	36,000	N/A	42,000	N/A	42,200
	Rated	N/A	24,000	N/A	29,000	N/A	32,500
Heating capacity @5°F (Btu/h)	Max	N/A	34,000	N/A	39,000	N/A	39,500
Heating capacity @-4°F (Btu/h)	Max	N/A	30,000	N/A	30,000	N/A	30,500
SEER/HSPF	Rated per AHRI 210/240	20.0	10.0	19.0	10.0	18.1	9.6
EER @95°F		12.0	12.1	10.5	11.8	9.7	10.5
Dehumidifying volume	pt/hr	8.24		9.37		12.35	
Power							
Rated power input	W	4.95	5.05				
Nominal input current	A	13.0	14.3	16.4	17.3	21.5	20.0

Notes:

- Nominal capacity based on 25 ft (7.6 m) of equivalent refrigerant piping with 0 ft (0 m) level difference.
Cooling: Indoor temperature 80° F DB, 67° F W; outdoor temperature 95° F DB, 75° F WB.
Heating: Indoor temperature 70° F DB, 60° F W; outdoor temperature 47° F DB, 43° F WB.
- Rated per AHRI-210/240 standard conditions.



Product Specification

Table 3. Indoor unit specifications for 18, 24, and 30 MBH capacity units

Indoor unit model number			4MUD4518A10N0A	4MUD4524A10N0A	4MUD4530A10N0A	
Fan	Motor type		BLDC	BLDC	BLDC	
	Output x n	W	183 x 1	183 x 1	183 x 2	
	FLA	A	0.85	0.85	#1 FLA 1.9 / #2 FLA 1.9	
	Fan type		Sirocco	Sirocco	Sirocco	
	Air flow rate H/M/L (dry coil)	cfm	CFM 565/494/388	CFM 706/618/530	954/883/742	
	External static pressure (Min/Std/Max)	in. HO	0.0/0.12/0.6	0.0/0.12/0.6	0.0/0.16/0.8	
Coil	Construction		Fin/Copper tube	Fin/Copper tube	Fin/Copper tube	
Sound	Sound pressure level (H/M/L)	dBa	34/30/26	36/32/28	37/33/29	
	Sound power level	dBa	56	58	59	
Standard components	Filter		Washable mesh	Washable mesh	Washable mesh	
	Condensate drain pump	Max. lifting height	in. (mm)	29 (0.74)	29 (0.74)	29 (0.74)
		Displacement	pint (liter)/hr.	50.7 (24)	50.7 (24)	50.7 (24)
Remote control	Wired remote control		TVCTRLTWRWD01T or TVCTRLTWR0002T	TVCTRLTWRWD01T or TVCTRLTWR0002T	TVCTRLTWRWD01T or TVCTRLTWR0002T	
	Wireless remote control		TVCTRLTRDH00UT	TVCTRLTRDH00UT	TVCTRLTRDH00UT	
Connections	Type		Flare	Flare	Flare	
	Liquid pipe	dia., in.	1/4	1/2	3/8	
	Gas pipe	dia., in.	1/2	5/8	5/8	
	Condensate drain	dia., in.	OD.98 (VP25), Id .79 (VP20)	OD.98 (VP25), Id .79 (VP20)	OD.98 (VP25), Id .79 (VP20)	
Dimensions	Net weight	lbs.	94.8	94.8	136.7	
	Shipping weight	lbs.	105.8	105.8	147.7	
	Net dimensions (WxHxD)	in.	45.275 x 12.6 x 18.9	45.275 x 12.6 x 18.9	47.25 x 14.175 x 25.6	
	Shipping dimensions (WxHxD)	in.	55.9 x 15.8 x 23.4	55.9 x 15.8 x 23.4	57.3 x 17.3 x 30.7	

Notes:

1. Sound pressure was acquired in a dead room. Actual noise level may be different depending on installation requirements.
2. Indoor unit receives power from the outdoor unit through field-supplied interconnecting wiring.
3. Unit includes an optional drain hose connection.

Table 4. Indoor unit specifications for 36, 42, and 48 MBH capacity units

Indoor unit model number			4MUD4536A10N0A	4MUD4542A10N0A	4MUD4548A10N0A	
Fan	Motor type		BLDC	BLDC	BLDC	
	Output x n	W	183 x 2	183 x 2	183 x 2	
	FLA	A	#1 FLA 1.9 / #2 FLA 1.9	#1 FLA 1.9 / #2 FLA 1.9	#1 FLA 1.9 / #2 FLA 1.9	
	Fan type		Sirocco	Sirocco	Sirocco	
	Air flow rate H/M/L (dry coil)	cfm	1130/954/777	1413/1271/1148	1519/1395/1271	
	External static pressure (Min/Std/Max)	in. HO	0.12/0.16/0.8	42-48 ESP 0.16/0.2/.08	0.0/0.2/0.8	
Coil	Construction		Fin/Copper tube	Fin/Copper tube	Fin/Copper tube	
Sound	Sound pressure level (H/M/L)	dBa	38/34/30	40/37/34	43/40/37	
	Sound power level	dBa	60	62	65	
Standard components	Filter		Washable mesh	Washable mesh	Washable mesh	
	Condensate drain pump	Max. lifting height	in. (mm)	29 (0.74)	29 (0.74)	29 (0.74)
		Displacement	pint (liter)/hr	50.7 (24)	50.7 (24)	50.7 (24)
Remote control	Wired remote control		TVCTRLTWRWD01T or TVCTRLTWR001T	TVCTRLTWRWD01T or TVCTRLTWR001T	TVCTRLTWRWD01T or TVCTRLTWR001T	
	Wireless remote control		TVCTRLTRDH00UT	TVCTRLTRDH00UT	TVCTRLTRDH00UT	
Connections	Type		Flare	Flare	Flare	
	Liquid pipe	dia., in.	3/8	3/8	3/8	
	Gas pipe	dia., in.	5/8	5/8	5/8	
	Condensate drain	dia., in.	OD.98 (VP25), Id .79 (VP20)	OD.98 (VP25), Id .79 (VP20)	OD.98 (VP25), Id .79 (VP20)	
Dimensions	Net weight	lbs.	136.7	136.7	136.7	
	Shipping weight	lbs.	147.7	147.7	147.7	
	Net dimensions (WxHxD)	in.	47.25 x 14.175 x 25.6	47.25 x 14.175 x 25.6	47.25 x 14.175 x 25.6	
	Shipping dimensions (WxHxD)	in.	57.3 x 17.3 x 30.7	57.3 x 17.3 x 30.7	57.3 x 17.3 x 30.7	

Notes:

1. Sound pressure was acquired in a dead room. Actual noise level may be different depending on installation requirements.
2. Indoor unit receives power from the outdoor unit through field-supplied interconnecting wiring.
3. Unit includes an optional drain hose connection.



Product Specification

Table 5. Outdoor unit specifications for 18, 24, and 30 MBH capacity units

Outdoor Unit Model Number		4TUK4518A10N0A	4TUK4524A10N0A	4TUK4530A10N0A	
Compressor	Type	Rotary inverter			
	Oil	POE			
	RLA	A	6.1	9.0	15.1
Fan	Motor type	BLDC			
	Output x n	W	39 x 1	125 x 1	125 x 1
	FLA	A	0.13	0.48	0.48
	Fan type	Propeller			
	Air flow rate	cfm	1550	2190	2220
Electrical	MCA	A	7.7	11.7	19.3
	MOP	A	15.0	20.0	30.0
Coil	Construction	Aluminum micro channel			
Sound	Sound pressure level (C _{lg} /H _{tg})	dB _A	48/48	50/50	50/52
	Sound power level	dB _A	62	65	65
Connections	Type	Flare			
	Liquid pipe	dia., in.	1/4	1/4	3/8
	Gas pipe	dia., in.	1/2	5/8	5/8
Dimensions	Net weight	lbs.	99.2	142.2	154.3
	Shipping weight	lbs.	105.8	153.2	163.1
	Net dimensions (WxHxD)	in.	34.65 x 25.1 x 12.2	37.0 x 39.3 x 13.0	37.0 x 39.3 x 13.0
	Shipping dimensions (WxHxD)	in.	40.25 x 29.5 x 16.25	39.1875 x 43.125 x 16.75	39.1875 x 43.125 x 16.75
Refrigerant	Type	R-410A			
	Control method	EEV			
	Factory charge	oz.	45.86	74.08	91.71
	Additional charge	g/m	10	10	22
		oz./ft	0.11	0.11	0.24

Note: Sound pressure was acquired in a dead room. Actual noise level may be different depending on installation requirements.

Table 6. Outdoor unit specifications for 36, 42, and 48 capacity units

Outdoor Unit Model Number			4TUK4536A10N0A	4TUK4542A10N0A	4TUK4548A10N0A
Compressor	Type		Rotary inverter	Rotary inverter	Rotary inverter
	Oil		POE	POE	POE
	RLA	A	17.0	17.0	17.0
Fan	Motor type		BLDC	BLDC	BLDC
	Output x n	W	125 x 2	125 x 2	125 x 2
	FLA	A	0.48 x 2	0.48 x 2	0.48 x 2
	Fan type		Propeller	Propeller	Propeller
	Air flow rate	cfm	3040	3040	3040
Electrical	MCA	A	22.2	22.2	22.2
	MOP	A	35.0	35.0	35.0
Coil	Construction		Aluminum micro channel	Aluminum micro channel	Aluminum micro channel
Sound	Sound pressure level (Clg/Htg)	dBA	49/51	51/53	53/55
	Sound power level	dBA	65	66	67
Connections	Type		Flare	Flare	Flare
	Liquid pipe	dia., in.	3/8	3/8	3/8
	Gas pipe	dia., in.	5/8	5/8	5/8
Dimensions	Net weight	lbs.	194	194	194
	Shipping weight	lbs.	216.1	216.1	216.1
	Net dimensions (WxHxD)	in.	37.0 x 47.65 x 13.0	37.0 x 47.65 x 13.0	37.0 x 47.65 x 13.0
	Shipping dimensions (WxHxD)	in.	39.1875 x 54.625 x 16.75	39.1875 x 54.625 x 16.75	39.1875 x 54.625 x 16.75
Refrigerant	Type		R-410A	R-410A	R-410A
	Control method		EEV	EEV	EEV
	Factory charge	oz.	98.77	98.77	98.77
	Additional charge	g/m	33	33	33
		oz./ft	0.35	0.35	0.35

Note: Sound pressure was acquired in a dead room. Actual noise level may be different depending on installation requirements.



Product Specification

Table 7. Application limit specification for 18, 24, and 30 capacity units

Application limits			4MUD4518A10N0A/ 4TUK4518A10N0A	4MUD4524A10N0A/ 4TUK4524A10N0A	4MUD4530A10N0A/ 4TUK4530A10N0A
Outdoor unit operating range	Cooling	Without wind baffle	23–115° F (-5–46.1°C)	23–115° F (-5–46.1°C)	23–115° F (-5–46.1°C)
		With wind baffle	0–115° F (-17.8–46.1°C)	0–115° F (-17.8–46.1°C)	0–115° F (-17.8–46.1°C)
	Heating		-4–75° F (-20–23.9°C)	-4–75° F (-20–23.9°C)	-4–75° F (-20–23.9°C)
Refrigerant piping	Max. length ft (m)		98 (29.9)	164 (50)	164 (50)
	Max. length with no additional refrigerant ft (m)		25 (50)	25 (50)	25 (50)
	Max. height difference ft (m)		66 (20.1)	98 (29.9)	98 (29.9)

Table 8. Application limit specification for 36, 42 and 48 capacity units

Application limits			4MUD4536A10N0A/ 4TUK4536A10N0A	4MUD4542A10N0A/ 4TUK4542A10N0A	4MUD4548A10N0A/ 4TUK4548A10N0A
Outdoor unit operating range	Cooling	Without wind baffle	23–115° F (-5–46.1°C)	23–115° F (-5–46.1°C)F	23–115° F (-5–46.1°C)
		With wind baffle	0–115° F (-17.8–46.1°C)	0–115° F (-17.8–46.1°C)	0–115° F (-17.8–46.1°C)
	Heating		-4–75° F (-20–23.9°C)	-4–75° F (-20–23.9°C)	-4–75° F (-20–23.9°C)
Refrigerant piping	Max. length ft (m)		246 (75)	246 (75)	246 (75)
	Max. length with no additional refrigerant ft (m)		25 (7.6)	25 (7.6)	25 (7.6)
	Max. height difference ft (m)		98 (29.9)	98 (29.9)	98 (29.9)



Capacity Tables

Table 9. Capacity table for 4MUD4518A10N0A and 4TUK4518A10N0A (68°F, 73°F, 79°F, and 80°F): cooling

Outdoor Air Temp. (°F DB)	Indoor Temperature (°F)							
	68 (20.0°C, DB)		73 (22.8°C, DB)		79 (26.1°C, DB)		80 (26.7°C, DB)	
	57 (13.9°C, WB)		61 (19.4°C, WB)		64 (17.8°C, WB)		67 (19.4°C, WB)	
	TC (Btu/h)	SHC (Btu/h)	TC (Btu/h)	SHC (Btu/h)	TC (Btu/h)	SHC (Btu/h)	TC (Btu/h)	SHC (Btu/h)
0	19.7	15.7	20.2	16.1	20.7	16.6	21.1	16.9
10	19.9	15.9	20.4	16.3	20.9	16.8	21.3	17.1
20	20.1	16.1	20.6	16.5	21.2	16.9	21.6	17.2
30	20.3	16.2	20.8	16.7	21.4	17.1	21.8	17.4
40	20.5	16.4	21.1	16.8	21.6	17.3	22.0	17.6
50	20.7	16.6	21.3	17.0	21.8	17.5	22.2	17.8
54	20.8	16.6	21.4	17.1	21.9	17.5	22.3	17.9
58	20.9	16.7	21.4	17.2	22.0	17.6	22.4	17.9
60	20.9	16.7	21.5	17.2	22.1	17.7	22.5	18.0
64	21.0	16.8	21.6	17.3	22.2	17.7	22.6	18.1
67	21.1	16.9	21.6	17.3	22.2	17.8	22.6	18.1
70	21.1	16.9	21.7	17.4	22.3	17.8	22.7	18.2
73	20.6	16.5	21.2	16.9	21.7	17.4	22.1	17.7
77	19.9	15.9	20.5	16.4	21.0	16.8	21.4	17.1
80	19.4	15.5	19.9	15.9	20.4	16.4	20.8	16.7
84	18.7	15.0	19.2	15.4	19.7	15.8	20.1	16.1
88	18.0	14.4	18.5	14.8	19.0	15.2	19.3	15.5
92	17.3	13.8	17.8	14.2	18.2	14.6	18.6	14.9
95	16.8	13.4	17.2	13.8	17.7	14.1	18.0	14.4
99	16.3	13.0	16.7	13.4	17.2	13.7	17.5	14.0
103	15.8	12.7	16.3	13.0	16.7	13.4	17.0	13.6
107	15.4	12.3	15.8	12.6	16.2	13.0	16.5	13.2
111	14.9	11.9	15.3	12.2	15.7	12.6	16.0	12.8
115	14.4	11.6	14.8	11.9	15.2	12.2	15.5	12.4

Notes:

1. Capacity index: Total capacity (TC) = 18 MBh; sensible heat capacity (SHC) = 14.4 MBh.
2. Indoor air temperatures (F° DB/WB) in cooling mode: 68/57, 72/61, 77/64, 80/67, 86/72, 90/75.
3. Refrigerant piping length: 16.4 ft (5 m)
4. Level difference : 0 ft (0 m)



Capacity Tables

Table 10. Capacity table for 4MUD4518A10N0A and 4TUK4518A10N0A (85°F, 87°F, and 89°F): cooling

Outdoor Air Temp. (°F DB)	Indoor Temperature (°F)					
	85 (29.4°C, DB)		87 (30.6°C, DB)		89 (31.7°C, DB)	
	70 (21.1°C, WB)		72 (22.2°C, WB)		75 (23.9°C, WB)	
	TC (Btu/h)	SHC (Btu/h)	TC (Btu/h)	SHC (Btu/h)	TC (Btu/h)	SHC (Btu/h)
0	21.6	17.3	22.0	17.6	22.1	17.7
10	21.9	17.5	22.2	17.8	22.4	17.9
20	22.1	17.7	22.4	17.9	22.6	18.1
30	22.3	17.9	22.7	18.1	22.8	18.3
40	22.6	18.1	22.9	18.3	23.1	18.5
50	22.8	18.2	23.1	18.5	23.3	18.7
54	22.9	18.3	23.2	18.6	23.4	18.7
58	23.0	18.4	23.3	18.7	23.5	18.8
60	23.0	18.4	23.4	18.7	23.6	18.9
64	23.1	18.5	23.5	18.8	23.7	18.9
67	23.2	18.6	23.5	18.8	23.7	19.0
70	23.3	18.6	23.6	18.9	23.8	19.0
73	22.7	18.2	23.0	18.4	23.2	18.6
77	21.9	17.5	22.2	17.8	22.4	17.9
80	21.3	17.1	21.7	17.3	21.8	17.5
84	20.6	16.5	20.9	16.7	21.0	16.8
88	19.8	15.8	20.1	16.1	20.3	16.2
92	19.0	15.2	19.3	15.5	19.5	15.6
95	18.5	14.8	18.7	15.0	18.9	15.1
99	17.9	14.4	18.2	14.6	18.4	14.7
103	17.4	13.9	17.7	14.1	17.8	14.3
107	16.9	13.5	17.2	13.7	17.3	13.8
111	16.4	13.1	16.6	13.3	16.8	13.4
115	15.9	12.7	16.1	12.9	16.3	13.0

Notes:

1. Capacity index: Total capacity (TC) = 18 MBh; sensible heat capacity (SHC) = 14.4 MBh.
2. Indoor air temperatures (F° DB/WB) in cooling mode: 68/57, 72/61, 77/64, 80/67, 86/72, 90/75.
3. Refrigerant piping length: 16.4 ft (5 m)
4. Level difference : 0 ft (0 m)

Table 11. Capacity tables for 4MUD4518A10N0A and 4TUK4518A10N0A: heating

Outdoor Air Temp. (°F)	Indoor temperature (°F DB)				
	61 (16.1°C)	65 (16.1°C)	70 (21.1°C)	72 (22.2°C)	75 (23.8°C)
	TC	TC	TC	TC	TC
DB	Btu/h	Btu/h	Btu/h	Btu/h	Btu/h
-4.0	9.9	9.8	9.6	9.5	9.4
-1.0	11.1	11.0	10.7	10.6	10.5
2	12.2	12.1	11.9	11.7	11.6
6	13.8	13.6	13.4	13.2	13.1
10	15.2	15.1	14.8	14.7	14.5
13	16.6	16.4	16.1	15.9	15.8
17	17.1	16.9	16.6	16.4	16.2
19	17.3	17.1	16.8	16.6	16.5
23	17.8	17.6	17.2	17.1	16.9
26	18.1	17.9	17.6	17.4	17.2
30	18.6	18.4	18.1	17.9	17.7
35	19.2	19.0	18.6	18.4	18.2
39	19.6	19.4	19.1	18.9	18.7
44	20.2	20.0	19.6	19.5	19.3
47	20.6	20.4	20.0	19.8	19.6
51	21.3	21.1	20.6	20.4	20.2
54	21.8	21.6	21.2	20.9	20.7
57	22.3	22.1	21.6	21.4	21.2
60	22.8	22.6	22.1	21.9	21.7
65	23.6	23.4	23.0	22.7	22.5
70	24.5	24.3	23.8	23.5	23.3
75	25.3	25.1	24.6	24.4	24.1

Notes:

1. Capacity index: Total capacity (TC) = 20 MBh
2. Rated heating capacity is at 47°F DB/ 43°F WB.
3. Refrigerant piping length: 16.4 ft (5 m)
4. Level difference : 0 ft (0 m)



Capacity Tables

Table 12. Capacity table for 4MUD4524A10N0A and 4TUK4524A10N0A (68°F, 73°F, 79°F, and 80°F): cooling

Outdoor Air Temp. (°F DB)	Indoor Temperature (°F)							
	68 (20.0°C, DB)		73 (22.8°C, DB)		79 (26.1°C, DB)		80 (26.7°C, DB)	
	57 (13.9°C, WB)		61 (19.4°C, WB)		64 (17.8°C, WB)		67 (19.4°C, WB)	
	TC (Btu/h)	SHC (Btu/h)	TC (Btu/h)	SHC (Btu/h)	TC (Btu/h)	SHC (Btu/h)	TC (Btu/h)	SHC (Btu/h)
0	25.2	20.2	25.9	20.7	26.6	21.3	27.1	21.7
10	25.3	20.2	26.0	20.8	26.7	21.3	27.2	21.7
20	25.4	20.3	26.0	20.8	26.7	21.4	27.2	21.8
30	25.4	20.3	26.1	20.9	26.8	21.4	27.3	21.8
40	25.5	20.4	26.1	20.9	26.8	21.5	27.3	21.9
50	25.5	20.4	26.2	21.0	26.9	21.5	27.4	21.9
54	25.5	20.4	26.2	21.0	26.9	21.5	27.4	21.9
58	25.6	20.4	26.2	21.0	26.9	21.6	27.4	21.9
60	25.6	20.5	26.2	21.0	26.9	21.6	27.4	22.0
64	25.6	20.5	26.3	21.0	27.0	21.6	27.5	22.0
67	25.6	20.5	26.3	21.0	27.0	21.6	27.5	22.0
70	25.6	20.5	26.3	21.0	27.0	21.6	27.5	22.0
73	25.2	20.2	25.9	20.7	26.6	21.3	27.1	21.7
77	24.7	19.8	25.4	20.3	26.0	20.8	26.5	21.2
80	24.3	19.5	25.0	20.0	25.6	20.5	26.1	20.9
84	23.8	19.0	24.4	19.5	25.1	20.1	25.5	20.4
88	23.3	18.6	23.9	19.1	24.5	19.6	25.0	20.0
92	22.7	18.2	23.4	18.7	24.0	19.2	24.4	19.5
95	22.4	17.9	23.0	18.4	23.6	18.9	24.0	19.2
99	22.1	17.7	22.7	18.1	23.3	18.6	23.7	19.0
103	21.8	17.4	22.4	17.9	23.0	18.4	23.4	18.7
107	21.5	17.2	22.1	17.7	22.7	18.1	23.1	18.5
111	21.2	17.0	21.8	17.4	22.4	17.9	22.8	18.2
115	21.0	16.8	21.5	17.2	22.1	17.7	22.5	18.0

Notes:

1. Capacity index: Total capacity (TC) = 24 MBh; sensible heat capacity (SHC) = 19.2 MBh.
2. Indoor air temperatures (F° DB/WB) in cooling mode: 68/57, 72/61, 77/64, 80/67, 86/72, 90/75.
3. Refrigerant piping length: 16.4 ft (5 m)
4. Level difference : 0 ft (0 m)

Table 13. Capacity table for 4MUD4524A10N0A and 4TUK4524A10N0A (85°F, 87°F, and 89°F): cooling

Outdoor Air Temp. (°F DB)	Indoor Temperature (°F)					
	85 (29.4°C, DB)		87 (30.6°C, DB)		89 (31.7°C, DB)	
	70 (21.1°C, WB)		72 (22.2°C, WB)		75 (23.9°C, WB)	
	TC (Btu/h)	SHC (Btu/h)	TC (Btu/h)	SHC (Btu/h)	TC (Btu/h)	SHC (Btu/h)
0	27.8	22.2	28.2	22.6	28.4	22.7
10	27.8	22.3	28.3	22.6	28.5	22.8
20	27.9	22.3	28.3	22.7	28.5	22.8
30	28.0	22.4	28.4	22.7	28.6	22.9
40	28.0	22.4	28.4	22.7	28.7	22.9
50	28.1	22.5	28.5	22.8	28.7	23.0
54	28.1	22.5	28.5	22.8	28.7	23.0
58	28.1	22.5	28.5	22.8	28.8	23.0
60	28.1	22.5	28.6	22.8	28.8	23.0
64	28.2	22.5	28.6	22.9	28.8	23.0
67	28.2	22.5	28.6	22.9	28.8	23.1
70	28.2	22.6	28.6	22.9	28.8	23.1
73	27.8	22.2	28.2	22.5	28.4	22.7
77	27.2	21.7	27.6	22.1	27.8	22.2
80	26.8	21.4	27.2	21.7	27.4	21.9
84	26.2	20.9	26.6	21.3	26.8	21.4
88	25.6	20.5	26.0	20.8	26.2	21.0
92	25.0	20.0	25.4	20.3	25.6	20.5
95	24.6	19.7	25.0	20.0	25.2	20.1
99	24.3	19.4	24.7	19.7	24.9	19.9
103	24.0	19.2	24.3	19.5	24.5	19.6
107	23.7	18.9	24.0	19.2	24.2	19.4
111	23.4	18.7	23.7	19.0	23.9	19.1
115	23.1	18.5	23.4	18.7	23.6	18.9

Notes:

1. Capacity index: Total capacity (TC) = 24 MBh; sensible heat capacity (SHC) = 19.2 MBh.
2. Indoor air temperatures (F° DB/WB) in cooling mode: 68/57, 72/61, 77/64, 80/67, 86/72, 90/75.
3. Refrigerant piping length: 16.4 ft (5 m)
4. Level difference : 0 ft (0 m)



Capacity Tables

Table 14. Capacity tables for 4MUD4524A10N0A and 4TUK4524A10N0A: heating

Outdoor Air Temp. (°F)	Indoor temperature (°F DB)				
	61 (16.1°C)	65 (16.1°C)	70 (21.1°C)	72 (22.2°C)	75 (23.8°C)
	TC	TC	TC	TC	TC
DB	Btu/h	Btu/h	Btu/h	Btu/h	Btu/h
-4.0	14.9	14.8	14.5	14.4	14.2
-1.0	15.9	15.8	15.5	15.3	15.2
2	16.9	16.8	16.4	16.3	16.1
6	18.3	18.1	17.7	17.6	17.4
10	19.5	19.4	19.0	18.8	18.6
13	20.7	20.5	20.1	19.9	19.7
17	21.5	21.3	20.9	20.7	20.5
19	22.0	21.7	21.3	21.1	20.9
23	22.8	22.6	22.1	21.9	21.7
26	23.4	23.2	22.7	22.5	22.3
30	24.3	24.0	23.6	23.3	23.1
35	25.3	25.0	24.5	24.3	24.1
39	26.1	25.9	25.3	25.1	24.8
44	27.2	26.9	26.4	26.1	25.9
47	27.8	27.5	27.0	26.7	26.5
51	29.0	28.7	28.2	27.9	27.6
54	30.0	29.7	29.1	28.8	28.5
57	30.9	30.6	30.0	29.7	29.4
60	31.8	31.5	30.9	30.6	30.3
65	33.4	33.1	32.4	32.1	31.8
70	34.9	34.6	33.9	33.6	33.2
75	36.5	36.1	35.4	35.0	34.7

Notes:

1. Capacity index: Total capacity (TC) = 27 MBh.
2. Rated heating capacity is at 47°F DB/ 43°F WB.
3. Refrigerant piping length: 16.4 ft (5 m)
4. Level difference : 0 ft (0 m)

Table 15. Capacity table for 4MUD4530A10N0A and 4TUK4530A10N0A (68°F, 73°F, 79°F, and 80°F): cooling

Outdoor Air Temp. (°F DB)	Indoor Temperature (°F)							
	68 (20.0°C, DB)		73 (22.8°C, DB)		79 (26.1°C, DB)		80 (26.7°C, DB)	
	57 (13.9°C, WB)		61 (19.4°C, WB)		64 (17.8°C, WB)		67 (19.4°C, WB)	
	TC (Btu/h)	SHC (Btu/h)	TC (Btu/h)	SHC (Btu/h)	TC (Btu/h)	SHC (Btu/h)	TC (Btu/h)	SHC (Btu/h)
0	32.4	25.9	33.3	26.6	34.2	27.3	34.8	27.8
10	32.4	25.9	33.2	26.6	34.1	27.3	34.7	27.8
20	32.3	25.9	33.2	26.5	34.1	27.2	34.7	27.7
30	32.3	25.8	33.1	26.5	34.0	27.2	34.6	27.7
40	32.2	25.8	33.1	26.5	33.9	27.2	34.6	27.7
50	32.2	25.7	33.0	26.4	33.9	27.1	34.5	27.6
54	32.1	25.7	33.0	26.4	33.9	27.1	34.5	27.6
58	32.1	25.7	33.0	26.4	33.8	27.1	34.5	27.6
60	32.1	25.7	33.0	26.4	33.8	27.1	34.5	27.6
64	32.1	25.7	32.9	26.3	33.8	27.1	34.4	27.5
67	32.1	25.7	32.9	26.3	33.8	27.0	34.4	27.5
70	32.0	25.6	32.9	26.3	33.8	27.0	34.4	27.5
73	31.6	25.2	32.4	25.9	33.3	26.6	33.9	27.1
77	30.9	24.7	31.7	25.4	32.6	26.1	33.2	26.5
80	30.4	24.3	31.2	25.0	32.1	25.6	32.6	26.1
84	29.8	23.8	30.5	24.4	31.4	25.1	31.9	25.5
88	29.1	23.3	29.9	23.9	30.7	24.5	31.2	25.0
92	28.4	22.8	29.2	23.4	30.0	24.0	30.5	24.4
95	27.9	22.4	28.7	23.0	29.5	23.6	30.0	24.0
99	27.0	21.6	27.7	22.2	28.4	22.8	29.0	23.2
103	26.0	20.8	26.7	21.4	27.4	21.9	27.9	22.3
107	25.0	20.0	25.7	20.6	26.4	21.1	26.9	21.5
111	24.1	19.3	24.7	19.8	25.4	20.3	25.8	20.7
115	23.1	18.5	23.7	19.0	24.4	19.5	24.8	19.8

Notes:

1. Capacity index: Total capacity (TC) = 30 MBh; sensible heat capacity (SHC) = 24 MBh.
2. Indoor air temperatures (F° DB/WB) in cooling mode: 68/57, 72/61, 77/64, 80/67, 86/72, 90/75.
3. Refrigerant piping length: 16.4 ft (5 m)
4. Level difference : 0 ft (0 m)



Capacity Tables

Table 16. Capacity table for 4MUD4530A10N0A and 4TUK4530A10N0A (85°F, 87°F, and 89°F): cooling

Outdoor Air Temp. (°F DB)	Indoor Temperature (°F)					
	85 (29.4°C, DB)		87 (30.6°C, DB)		89 (31.7°C, DB)	
	70 (21.1°C, WB)		72 (22.2°C, WB)		75 (23.9°C, WB)	
	TC (Btu/h)	SHC (Btu/h)	TC (Btu/h)	SHC (Btu/h)	TC (Btu/h)	SHC (Btu/h)
0	35.7	28.5	36.2	29.0	36.5	29.2
10	35.6	28.5	36.1	28.9	36.4	29.1
20	35.6	28.4	36.1	28.9	36.4	29.1
30	35.5	28.4	36.0	28.8	36.3	29.1
40	35.4	28.3	36.0	28.8	36.3	29.0
50	35.4	28.3	35.9	28.7	36.2	29.0
54	35.4	28.3	35.9	28.7	36.2	28.9
58	35.3	28.3	35.9	28.7	36.1	28.9
60	35.3	28.3	35.8	28.7	36.1	28.9
64	35.3	28.2	35.8	28.7	36.1	28.9
67	35.3	28.2	35.8	28.6	36.1	28.9
70	35.3	28.2	35.8	28.6	36.1	28.9
73	34.7	27.8	35.2	28.2	35.5	28.4
77	34.0	27.2	34.5	27.6	34.8	27.8
80	33.5	26.8	34.0	27.2	34.2	27.4
84	32.7	26.2	33.2	26.6	33.5	26.8
88	32.0	25.6	32.5	26.0	32.8	26.2
92	31.3	25.0	31.8	25.4	32.0	25.6
95	30.8	24.6	31.2	25.0	31.5	25.2
99	29.7	23.7	30.1	24.1	30.4	24.3
103	28.6	22.9	29.0	23.2	29.3	23.4
107	27.6	22.0	28.0	22.4	28.2	22.6
111	26.5	21.2	26.9	21.5	27.1	21.7
115	25.4	20.3	25.8	20.6	26.0	20.8

Notes:

1. Capacity index: Total capacity (TC) = 30 MBh; sensible heat capacity (SHC) = 24 MBh.
2. Indoor air temperatures (F° DB/WB) in cooling mode: 68/57, 72/61, 77/64, 80/67, 86/72, 90/75.
3. Refrigerant piping length: 16.4 ft (5 m)
4. Level difference : 0 ft (0 m)

Table 17. Capacity tables for 4MUD4530A10N0A and 4TUK4530A10N0A: heating

Outdoor Air Temp. (°F)	Indoor temperature (°F DB)				
	61 (16.1°C)	65 (16.1°C)	70 (21.1°C)	72 (22.2°C)	75 (23.8°C)
	TC	TC	TC	TC	TC
DB	Btu/h	Btu/h	Btu/h	Btu/h	Btu/h
-4.0	19.8	19.6	19.2	19.0	18.8
-1.0	20.6	20.4	20.0	19.8	19.6
2	21.3	21.1	20.7	20.5	20.3
6	22.3	22.1	21.7	21.5	21.3
10	23.3	23.1	22.6	22.4	22.2
13	35.1	34.8	34.1	33.8	33.4
17	34.9	34.5	33.9	33.5	33.2
19	34.7	34.4	33.7	33.4	33.1
23	34.5	34.2	33.5	33.2	32.8
26	34.3	34.0	33.3	33.0	32.6
30	34.0	33.7	33.1	32.7	32.4
35	33.7	33.4	32.7	32.4	32.1
39	33.5	33.2	32.5	32.2	31.9
44	33.2	32.8	32.2	31.9	31.5
47	33.0	32.6	32.0	31.7	31.4
51	34.4	34.1	33.4	33.1	32.7
54	35.5	35.2	34.5	34.2	33.8
57	36.6	36.2	35.5	35.2	34.8
60	37.7	37.4	36.6	36.3	35.9
65	39.6	39.2	38.4	38.1	37.7
70	41.4	41.0	40.2	39.8	39.4
75	43.3	42.8	42.0	41.6	41.2

Notes:

1. Capacity index: Total capacity (TC) = 32 MBh
2. Rated heating capacity is at 47°F DB/ 43°F WB.
3. Refrigerant piping length: 16.4 ft (5 m)
4. Level difference : 0 ft (0 m)



Capacity Tables

Table 18. Capacity table for 4MUD4536A10N0A and 4TUK4536A10N0A (68°F, 73°F, 79°F, and 80°F): cooling

Outdoor Air Temp. (°F DB)	Indoor Temperature (°F)							
	68 (20.0°C, DB)		73 (22.8°C, DB)		79 (26.1°C, DB)		80 (26.7°C, DB)	
	57 (13.9°C, WB)		61 (19.4°C, WB)		64 (17.8°C, WB)		67 (19.4°C, WB)	
	TC (Btu/h)	SHC (Btu/h)	TC (Btu/h)	SHC (Btu/h)	TC (Btu/h)	SHC (Btu/h)	TC (Btu/h)	SHC (Btu/h)
0	36.1	28.8	37.0	29.6	38.0	30.4	38.7	31.0
10	36.0	28.8	37.0	29.6	38.0	30.4	38.7	30.9
20	36.0	28.8	36.9	29.5	37.9	30.3	38.6	30.9
30	35.9	28.7	36.9	29.5	37.9	30.3	38.6	30.9
40	35.9	28.7	36.9	29.5	37.8	30.3	38.5	30.8
50	35.9	28.7	36.8	29.4	37.8	30.2	38.5	30.8
54	35.8	28.7	36.8	29.4	37.8	30.2	38.5	30.8
58	35.8	28.7	36.8	29.4	37.8	30.2	38.5	30.8
60	35.8	28.7	36.8	29.4	37.8	30.2	38.4	30.8
64	35.8	28.6	36.8	29.4	37.7	30.2	38.4	30.7
67	35.8	28.6	36.7	29.4	37.7	30.2	38.4	30.7
70	35.8	28.6	36.7	29.4	37.7	30.2	38.4	30.7
73	35.5	28.4	36.5	29.2	37.4	29.9	38.1	30.5
77	35.1	28.1	36.1	28.9	37.0	29.6	37.7	30.2
80	34.9	27.9	35.8	28.6	36.8	29.4	37.4	30.0
84	34.5	27.6	35.4	28.4	36.4	29.1	37.1	29.6
88	34.2	27.3	35.1	28.1	36.0	28.8	36.7	29.3
92	33.8	27.0	34.7	27.8	35.6	28.5	36.3	29.0
95	33.5	26.8	34.4	27.5	35.4	28.3	36.0	28.8
99	31.4	25.1	32.2	25.8	33.1	26.5	33.7	26.9
103	29.2	23.4	30.0	24.0	30.8	24.6	31.4	25.1
107	27.1	21.6	27.8	22.2	28.5	22.8	29.0	23.2
111	24.9	19.9	25.6	20.4	26.2	21.0	26.7	21.4
115	22.7	18.2	23.3	18.7	24.0	19.2	24.4	19.5

Notes:

1. Capacity index: Total capacity (TC) = 36 MBh; sensible heat capacity (SHC) = 28.8 MBh
2. Indoor air temperatures (F° DB/WB) in cooling mode: 68/57, 72/61, 77/64, 80/67, 86/72, 90/75.
3. Refrigerant piping length: 16.4 ft (5 m)
4. Level difference : 0 ft (0 m)

Table 19. Capacity table for 4MUD4536A10N0A and 4TUK4536A10N0A (85°F, 87°F, and 89°F): cooling

Outdoor Air Temp. (°F DB)	Indoor Temperature (°F)					
	85 (29.4°C, DB)		87 (30.6°C, DB)		89 (31.7°C, DB)	
	70 (21.1°C, WB)		72 (22.2°C, WB)		75 (23.9°C, WB)	
	TC (Btu/h)	SHC (Btu/h)	TC (Btu/h)	SHC (Btu/h)	TC (Btu/h)	SHC (Btu/h)
0	39.7	31.7	40.3	32.2	40.6	32.5
10	39.6	31.7	40.2	32.2	40.5	32.4
20	39.6	31.7	40.2	32.1	40.5	32.4
30	39.5	31.6	40.1	32.1	40.4	32.4
40	39.5	31.6	40.1	32.1	40.4	32.3
50	39.4	31.6	40.0	32.0	40.4	32.3
54	39.4	31.5	40.0	32.0	40.3	32.3
58	39.4	31.5	40.0	32.0	40.3	32.3
60	39.4	31.5	40.0	32.0	40.3	32.3
64	39.4	31.5	40.0	32.0	40.3	32.2
67	39.4	31.5	40.0	32.0	40.3	32.2
70	39.4	31.5	40.0	32.0	40.3	32.2
73	39.1	31.3	39.7	31.7	40.0	32.0
77	38.7	30.9	39.3	31.4	39.6	31.7
80	38.4	30.7	39.0	31.2	39.3	31.4
84	38.0	30.4	38.6	30.8	38.9	31.1
88	37.6	30.1	38.2	30.5	38.5	30.8
92	37.2	29.8	37.8	30.2	38.1	30.4
95	36.9	29.5	37.5	30.0	37.8	30.2
99	34.5	27.6	35.0	28.0	35.3	28.3
103	32.1	25.7	32.6	26.1	32.9	26.3
107	29.8	23.8	30.2	24.2	30.5	24.4
111	27.4	21.9	27.8	22.2	28.0	22.4
115	25.0	20.0	25.4	20.3	25.6	20.5

Notes:

1. Capacity index: Total capacity (TC) = 36 MBh; sensible heat capacity (SHC) = 28.8 MBh
2. Indoor air temperatures (F° DB/WB) in cooling mode: 68/57, 72/61, 77/64, 80/67, 86/72, 90/75.
3. Refrigerant piping length: 16.4 ft (5 m)
4. Level difference : 0 ft (0 m)



Capacity Tables

Table 20. Capacity tables for 4MUD4536A10N0A and 4TUK4536A10N0A: heating

Outdoor Air Temp. (°F)	Indoor temperature (°F DB)				
	61 (16.1°C)	65 (16.1°C)	70 (21.1°C)	72 (22.2°C)	75 (23.8°C)
	TC	TC	TC	TC	TC
DB	Btu/h	Btu/h	Btu/h	Btu/h	Btu/h
-4.0	30.5	30.2	29.6	29.3	29.0
-1.0	31.8	31.5	30.9	30.6	30.2
2	33.1	32.7	32.1	31.8	31.5
6	34.8	34.4	33.8	33.4	33.1
10	36.4	36.1	35.4	35.0	34.7
13	37.9	37.5	36.8	36.4	36.1
17	38.3	37.9	37.2	36.8	36.4
19	38.5	38.1	37.4	37.0	36.6
23	38.9	38.5	37.7	37.4	37.0
26	39.2	38.8	38.0	37.6	37.3
30	39.6	39.2	38.4	38.0	37.6
35	40.0	39.6	38.9	38.5	38.1
39	40.4	40.0	39.2	38.8	38.5
44	40.9	40.5	39.7	39.3	38.9
47	41.2	40.8	40.0	39.6	39.2
51	42.3	41.9	41.1	40.7	40.3
54	43.2	42.8	42.0	41.5	41.1
57	44.0	43.6	42.8	42.3	41.9
60	44.9	44.5	43.6	43.2	42.7
65	46.4	45.9	45.0	44.6	44.1
70	47.8	47.3	46.4	45.9	45.5
75	49.2	48.8	47.8	47.3	46.8

Notes:

1. Capacity index: Total capacity (TC) = 40 MBh
2. Rated heating capacity is at 47°F DB/ 43°F WB.
3. Refrigerant piping length: 16.4 ft (5 m)
4. Level difference : 0 ft (0 m)

Table 21. Capacity table for 4MUD4542A10N0A and 4TUK4542A10N0A (68°F, 73°F, 79°F, and 80°F): cooling

Outdoor Air Temp. (°F DB)	Indoor Temperature (°F)							
	68 (20.0°C, DB)		73 (22.8°C, DB)		79 (26.1°C, DB)		80 (26.7°C, DB)	
	57 (13.9°C, WB)		61 (19.4°C, WB)		64 (17.8°C, WB)		67 (19.4°C, WB)	
	TC (Btu/h)	SHC (Btu/h)	TC (Btu/h)	SHC (Btu/h)	TC (Btu/h)	SHC (Btu/h)	TC (Btu/h)	SHC (Btu/h)
0	42.0	33.6	43.1	34.5	44.3	35.4	45.1	36.1
10	41.9	33.5	43.0	34.4	44.1	35.3	44.9	36.0
20	41.7	33.4	42.8	34.3	44.0	35.2	44.8	35.8
30	41.6	33.3	42.7	34.1	43.8	35.1	44.6	35.7
40	41.4	33.1	42.5	34.0	43.7	34.9	44.5	35.6
50	41.3	33.0	42.4	33.9	43.5	34.8	44.3	35.5
54	41.2	33.0	42.3	33.9	43.5	34.8	44.3	35.4
58	41.2	32.9	42.3	33.8	43.4	34.7	44.2	35.4
60	41.1	32.9	42.2	33.8	43.4	34.7	44.2	35.3
64	41.1	32.9	42.2	33.7	43.3	34.6	44.1	35.3
67	41.0	32.8	42.1	33.7	43.3	34.6	44.0	35.2
70	41.0	32.8	42.1	33.7	43.2	34.6	44.0	35.2
73	40.8	32.6	41.9	33.5	43.0	34.4	43.8	35.0
77	40.5	32.4	41.5	33.2	42.7	34.1	43.4	34.8
80	40.2	32.2	41.3	33.1	42.4	33.9	43.2	34.6
84	39.9	32.0	41.0	32.8	42.1	33.7	42.9	34.3
88	39.6	31.7	40.7	32.6	41.8	33.4	42.6	34.0
92	39.4	31.5	40.4	32.3	41.5	33.2	42.2	33.8
95	39.1	31.3	40.2	32.1	41.2	33.0	42.0	33.6
99	37.0	29.6	38.0	30.4	39.0	31.2	39.7	31.8
103	34.8	27.9	35.8	28.6	36.7	29.4	37.4	29.9
107	32.7	26.2	33.6	26.9	34.5	27.6	35.1	28.1
111	30.6	24.4	31.4	25.1	32.2	25.8	32.8	26.2
115	28.4	22.7	29.2	23.3	30.0	24.0	30.5	24.4

Notes:

1. Capacity index: Total capacity (TC) = 42 MBh; sensible heat capacity (SHC) = 33.6 MBh
2. Indoor air temperatures (F° DB/WB) in cooling mode: 68/57, 72/61, 77/64, 80/67, 86/72, 90/75.
3. Refrigerant piping length: 16.4 ft (5 m)
4. Level difference : 0 ft (0 m)



Capacity Tables

Table 22. Capacity table for 4MUD4542A10N0A and 4TUK4542A10N0A (85°F, 87°F, and 89°F): cooling

Outdoor Air Temp. (°F DB)	Indoor Temperature (°F)					
	85 (29.4°C, DB)		87 (30.6°C, DB)		89 (31.7°C, DB)	
	70 (21.1°C, WB)		72 (22.2°C, WB)		75 (23.9°C, WB)	
	TC (Btu/h)	SHC (Btu/h)	TC (Btu/h)	SHC (Btu/h)	TC (Btu/h)	SHC (Btu/h)
0	46.2	37.0	46.9	37.5	47.3	37.8
10	46.1	36.9	46.8	37.4	47.1	37.7
20	45.9	36.7	46.6	37.3	47.0	37.6
30	45.7	36.6	46.4	37.1	46.8	37.4
40	45.6	36.5	46.3	37.0	46.6	37.3
50	45.4	36.3	46.1	36.9	46.5	37.2
54	45.4	36.3	46.0	36.8	46.4	37.1
58	45.3	36.2	46.0	36.8	46.3	37.1
60	45.3	36.2	45.9	36.8	46.3	37.0
64	45.2	36.2	45.9	36.7	46.2	37.0
67	45.1	36.1	45.8	36.7	46.2	37.0
70	45.1	36.1	45.8	36.6	46.1	36.9
73	44.9	35.9	45.5	36.4	45.9	36.7
77	44.5	35.6	45.2	36.2	45.6	36.4
80	44.3	35.4	44.9	36.0	45.3	36.2
84	44.0	35.2	44.6	35.7	45.0	36.0
88	43.6	34.9	44.3	35.4	44.6	35.7
92	43.3	34.6	43.9	35.2	44.3	35.4
95	43.1	34.4	43.7	35.0	44.0	35.2
99	40.7	32.6	41.3	33.0	41.6	33.3
103	38.3	30.7	38.9	31.1	39.2	31.4
107	36.0	28.8	36.5	29.2	36.8	29.4
111	33.6	26.9	34.1	27.3	34.4	27.5
115	31.3	25.0	31.7	25.4	32.0	25.6

Notes:

1. Capacity index: Total capacity (TC) = 42 MBh; sensible heat capacity (SHC) = 33.6 MBh
2. Indoor air temperatures (F° DB/WB) in cooling mode: 68/57, 72/61, 77/64, 80/67, 86/72, 90/75.
3. Refrigerant piping length: 16.4 ft (5 m)
4. Level difference : 0 ft (0 m)

Table 23. Capacity tables for 4MUD4542A10N0A and 4TUK4542A10N0A: heating

Outdoor Air Temp. (°F)	Indoor temperature (°F DB)				
	61 (16.1°C)	65 (16.1°C)	70 (21.1°C)	72 (22.2°C)	75 (23.8°C)
	TC	TC	TC	TC	TC
DB	Btu/h	Btu/h	Btu/h	Btu/h	Btu/h
-4.0	26.9	26.6	26.1	25.8	25.6
-1.0	29.4	29.1	28.5	28.2	27.9
2	31.8	31.5	30.9	30.6	30.2
6	35.1	34.7	34.0	33.7	33.4
10	38.2	37.8	37.1	36.7	36.3
13	41.0	40.6	39.8	39.4	39.0
17	41.9	41.5	40.6	40.2	39.8
19	42.3	41.9	41.1	40.7	40.2
23	43.2	42.7	41.9	41.5	41.1
26	43.8	43.4	42.6	42.1	41.7
30	44.7	44.3	43.4	43.0	42.5
35	45.8	45.3	44.4	44.0	43.5
39	46.6	46.2	45.3	44.8	44.4
44	47.7	47.3	46.3	45.9	45.4
47	48.4	47.9	47.0	46.5	46.1
51	49.1	48.6	47.7	47.2	46.7
54	49.6	49.2	48.2	47.7	47.2
57	50.2	49.7	48.7	48.2	47.7
60	50.7	50.2	49.2	48.7	48.2
65	51.6	51.1	50.1	49.6	49.1
70	52.5	52.0	50.9	50.4	49.9
75	53.4	52.8	51.8	51.3	50.8

Notes:

1. Capacity index: Total capacity (TC) = 47 MBh
2. Rated heating capacity is at 47°F DB/ 43°F WB.
3. Refrigerant piping length: 16.4 ft (5 m)
4. Level difference : 0 ft (0 m)



Capacity Tables

Table 24. Capacity table for 4MUD4548A10N0A and 4TUK4548A10N0A (68°F, 73°F, 79°F, and 80°F): cooling

Outdoor Air Temp. (°F DB)	Indoor Temperature (°F)							
	68 (20.0°C, DB)		73 (22.8°C, DB)		79 (26.1°C, DB)		80 (26.7°C, DB)	
	57 (13.9°C, WB)		61 (19.4°C, WB)		64 (17.8°C, WB)		67 (19.4°C, WB)	
	TC (Btu/h)	SHC (Btu/h)	TC (Btu/h)	SHC (Btu/h)	TC (Btu/h)	SHC (Btu/h)	TC (Btu/h)	SHC (Btu/h)
0	50.1	40.1	51.5	41.2	52.8	42.3	53.8	43.0
10	50.0	40.0	51.3	41.1	52.7	42.2	53.7	42.9
20	49.9	39.9	51.2	40.9	52.6	42.0	53.5	42.8
30	49.7	39.8	51.0	40.8	52.4	41.9	53.4	42.7
40	49.6	39.7	50.9	40.7	52.3	41.8	53.2	42.6
50	49.5	39.6	50.8	40.6	52.1	41.7	53.1	42.5
54	49.4	39.5	50.7	40.6	52.1	41.7	53.0	42.4
58	49.3	39.5	50.7	40.5	52.0	41.6	53.0	42.4
60	49.3	39.5	50.6	40.5	52.0	41.6	52.9	42.4
64	49.3	39.4	50.6	40.5	51.9	41.5	52.9	42.3
67	49.2	39.4	50.5	40.4	51.9	41.5	52.8	42.3
70	49.2	39.4	50.5	40.4	51.8	41.5	52.8	42.2
73	48.7	38.9	50.0	40.0	51.3	41.0	52.2	41.8
77	47.9	38.3	49.2	39.4	50.5	40.4	51.5	41.2
80	47.4	37.9	48.7	38.9	50.0	40.0	50.9	40.7
84	46.7	37.3	47.9	38.3	49.2	39.4	50.1	40.1
88	46.0	36.8	47.2	37.8	48.5	38.8	49.3	39.5
92	45.3	36.2	46.5	37.2	47.7	38.2	48.6	38.9
95	44.7	35.8	45.9	36.7	47.1	37.7	48.0	38.4
99	41.6	33.3	42.7	34.2	43.8	35.1	44.6	35.7
103	38.5	30.8	39.5	31.6	40.5	32.4	41.3	33.0
107	35.3	28.3	36.3	29.0	37.2	29.8	37.9	30.3
111	32.2	25.8	33.1	26.4	33.9	27.2	34.6	27.6
115	29.1	23.3	29.8	23.9	30.6	24.5	31.2	25.0

Notes:

1. Capacity index: Total capacity (TC) = 48 MBh; sensible heat capacity (SHC) = 38.4 MBh
2. Indoor air temperatures (F° DB/WB) in cooling mode: 68/57, 72/61, 77/64, 80/67, 86/72, 90/75.
3. Refrigerant piping length: 16.4 ft (5 m)
4. Level difference : 0 ft (0 m)

Table 25. Capacity table for 4MUD4548A10N0A and 4TUK4548A10N0A (85°F, 87°F, and 89°F): cooling

Outdoor Air Temp. (°F DB)	Indoor Temperature (°F)					
	85 (29.4°C, DB)		87 (30.6°C, DB)		89 (31.7°C, DB)	
	70 (21.1°C, WB)		72 (22.2°C, WB)		75 (23.9°C, WB)	
	TC (Btu/h)	SHC (Btu/h)	TC (Btu/h)	SHC (Btu/h)	TC (Btu/h)	SHC (Btu/h)
0	55.1	44.1	56.0	44.8	56.4	45.1
10	55.0	44.0	55.8	44.7	56.3	45.0
20	54.9	43.9	55.7	44.5	56.1	44.9
30	54.7	43.8	55.5	44.4	56.0	44.8
40	54.6	43.6	55.4	44.3	55.8	44.7
50	54.4	43.5	55.2	44.2	55.7	44.5
54	54.4	43.5	55.2	44.1	55.6	44.5
58	54.3	43.4	55.1	44.1	55.6	44.4
60	54.3	43.4	55.1	44.1	55.5	44.4
64	54.2	43.4	55.0	44.0	55.5	44.4
67	54.2	43.3	55.0	44.0	55.4	44.3
70	54.1	43.3	54.9	43.9	55.4	44.3
73	53.5	42.8	54.3	43.5	54.8	43.8
77	52.7	42.2	53.5	42.8	54.0	43.2
80	52.2	41.7	52.9	42.3	53.4	42.7
84	51.4	41.1	52.1	41.7	52.6	42.0
88	50.6	40.5	51.3	41.1	51.7	41.4
92	49.8	39.8	50.5	40.4	50.9	40.8
95	49.2	39.4	49.9	40.0	50.3	40.3
99	45.8	36.6	46.4	37.2	46.8	37.5
103	42.3	33.8	42.9	34.4	43.3	34.6
107	38.9	31.1	39.5	31.6	39.8	31.8
111	35.4	28.3	36.0	28.8	36.2	29.0
115	32.0	25.6	32.5	26.0	32.7	26.2

Notes:

1. Capacity index: Total capacity (TC) = 48 MBh; sensible heat capacity (SHC) = 38.4 MBh
2. Indoor air temperatures (F° DB/WB) in cooling mode: 68/57, 72/61, 77/64, 80/67, 86/72, 90/75.
3. Refrigerant piping length: 16.4 ft (5 m)
4. Level difference : 0 ft (0 m)



Capacity Tables

Table 26. Capacity table for 4MUD4548A10N0A and 4TUK4548A10N0A: heating

Outdoor Air Temp. (°F)	Indoor temperature (°F DB)				
	61 (16.1°C)	65 (16.1°C)	70 (21.1°C)	72 (22.2°C)	75 (23.8°C)
	TC	TC	TC	TC	TC
DB	Btu/h	Btu/h	Btu/h	Btu/h	Btu/h
-4.0	29.0	28.8	28.2	27.9	27.6
-1.0	31.6	31.3	30.7	30.4	30.1
2	34.1	33.8	33.1	32.8	32.4
6	37.5	37.1	36.4	36.0	35.6
10	40.7	40.3	39.5	39.1	38.7
13	43.6	43.1	42.3	41.9	41.5
17	44.9	44.4	43.6	43.1	42.7
19	45.5	45.1	44.2	43.7	43.3
23	46.8	46.3	45.4	45.0	44.5
26	47.8	47.3	46.4	45.9	45.5
30	49.1	48.6	47.7	47.2	46.7
35	50.7	50.2	49.2	48.7	48.2
39	52.0	51.4	50.4	49.9	49.4
44	53.6	53.1	52.0	51.5	51.0
47	54.6	54.1	53.0	52.5	51.9
51	55.8	55.2	54.1	53.6	53.1
54	56.7	56.1	55.0	54.5	53.9
57	57.5	56.9	55.8	55.3	54.7
60	58.4	57.8	56.7	56.1	55.6
65	59.9	59.3	58.1	57.6	57.0
70	61.4	60.8	59.6	59.0	58.4
75	62.8	62.2	61.0	60.4	59.8

Notes:

1. Capacity index: Total capacity (TC) = 53 MBh
2. Rated heating capacity is at 47°F DB/ 43°F WB.
3. Refrigerant piping length: 16.4 ft (5 m)
4. Level difference : 0 ft (0 m)



Unit Dimensions

Indoor Unit Dimensions

4MUD4518A10N0A and 4MUD4524A10N0A

Unit: inch (mm)

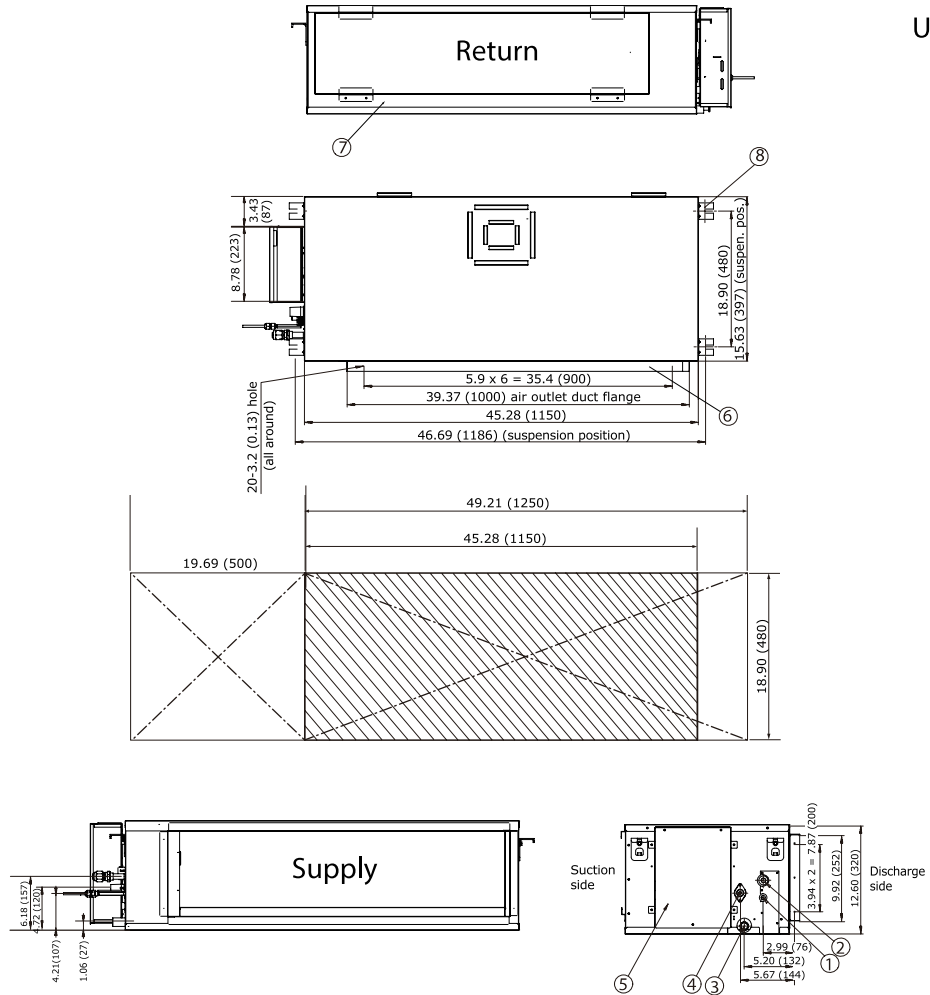

No.	Name	Description
1	Liquid pipe connection	1/4 (6.35)
2	Gas pipe connection	18 MBH: 1/2 (12.7); 24 MBH: 5/8 (15.88)
3	Drain pipe connection (without optional drain pump)	OD 1 (25), ID 0.78 (20)
4	Drain pipe connection (with optional drain pump)	OD 1 (25), ID 0.78 (20)
5	Power supply/communications connection	—
6	Air discharge grill flange	—
7	Air filter	—
8	Mounting hooks	M8-M10



Unit Dimensions

4MUD4530A10N0A, 4MUD4536A10N0A, 4MUD4542A10N0A and 4MUD4548A10N0A

Unit: inch (mm)

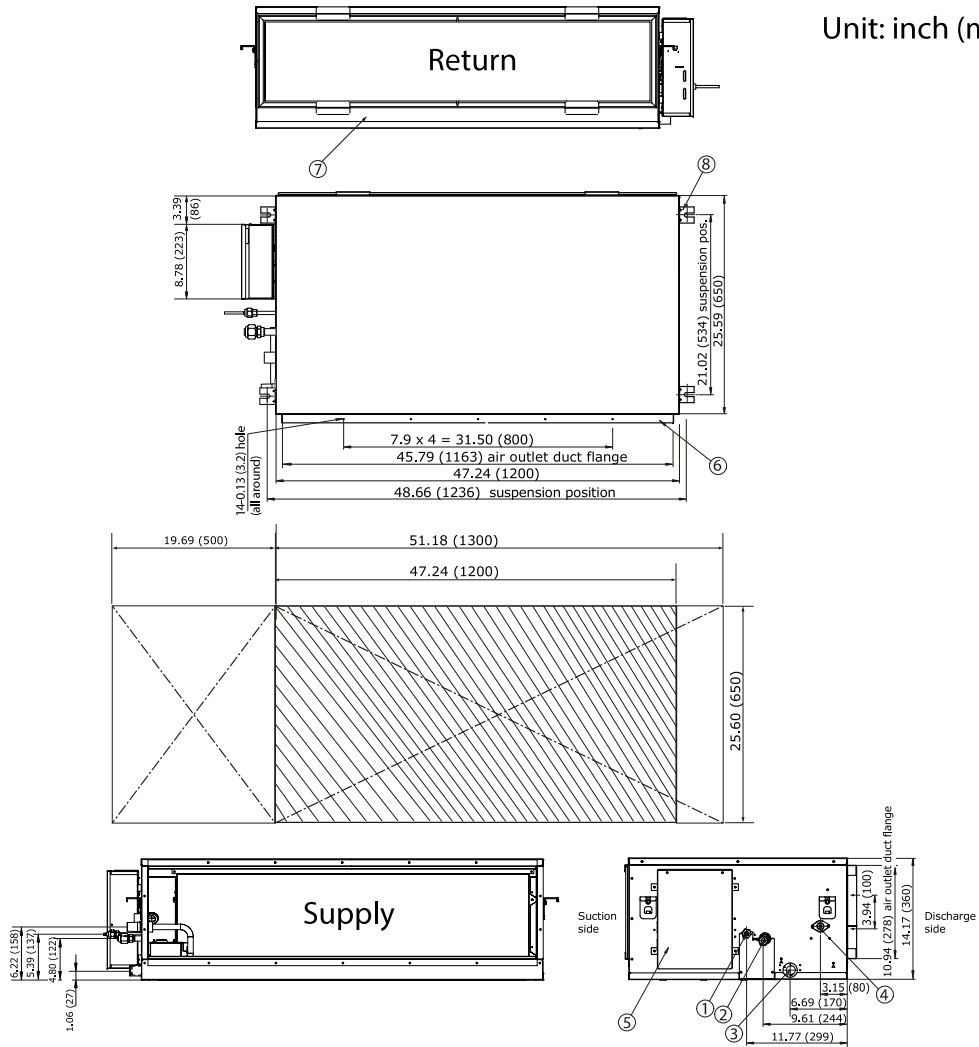

No.	Name	Description
1	Liquid pipe connection	3/8 (9.52)
2	Gas pipe connection	5/8 (15.88)
3	Drain pipe connection (without optional drain pump)	OD 1 (25), ID 0.78 (20)
4	Drain pipe connection (with optional drain pump)	OD 1 (25), ID 0.78 (20)
5	Power supply/communications connection	—
6	Air discharge grill flange	—
7	Air filter	—
8	Mounting hooks	M8-M10

Outdoor Unit Dimensions

Figure 1. Dimensional drawing for 18 MBH capacity units

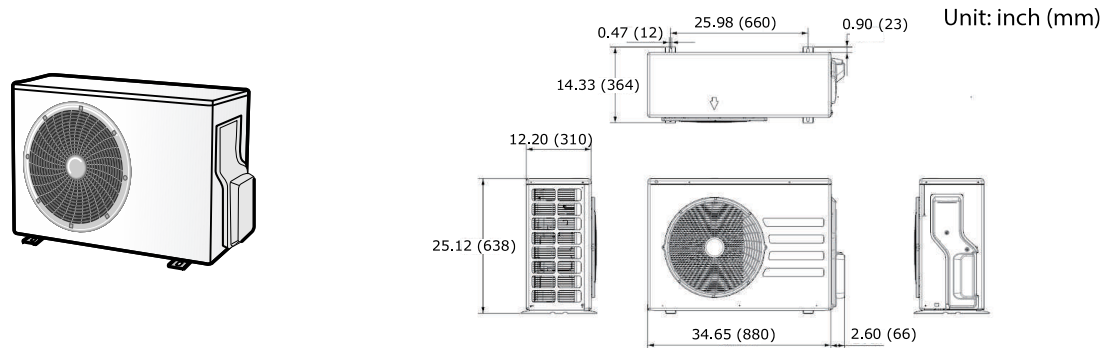

Figure 2. Dimensional drawing for 24 and 30 MBH capacity units

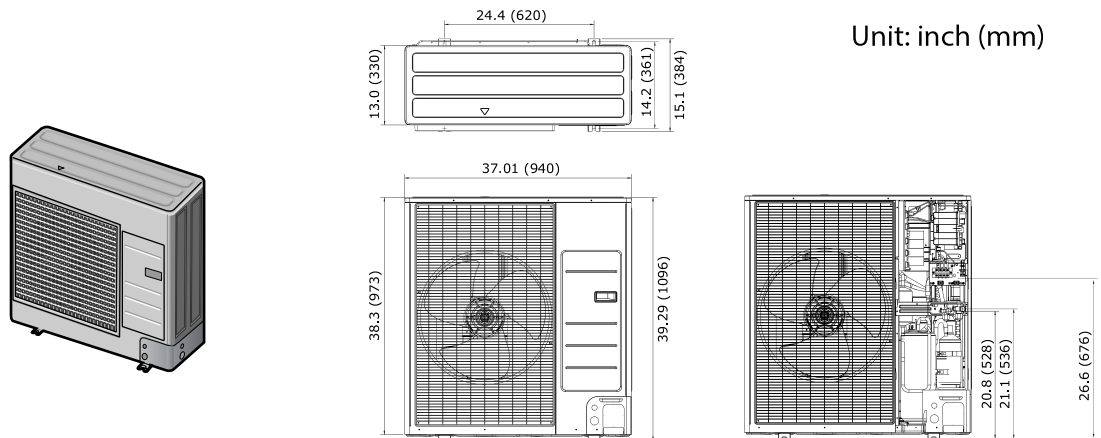
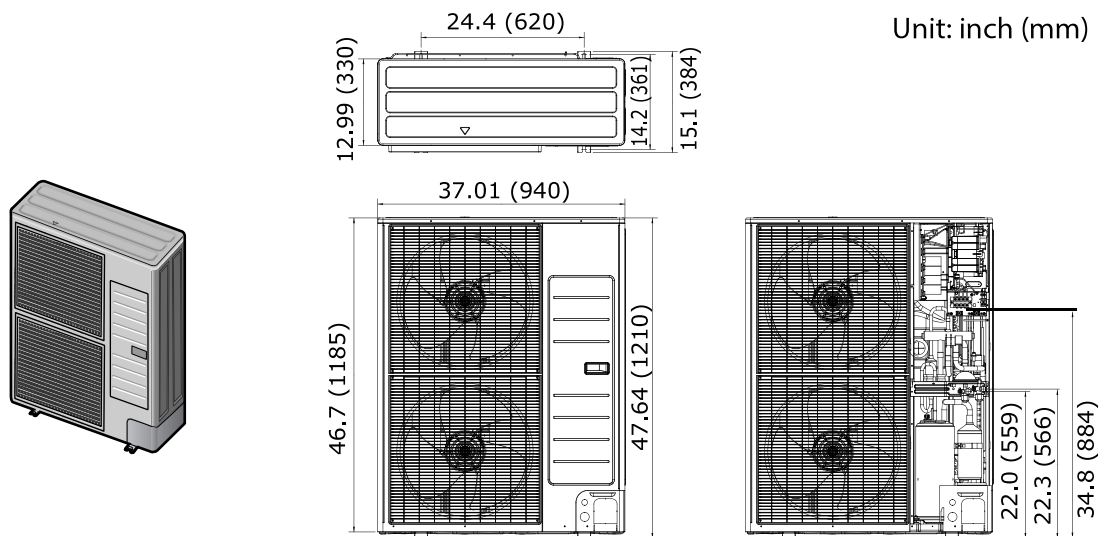
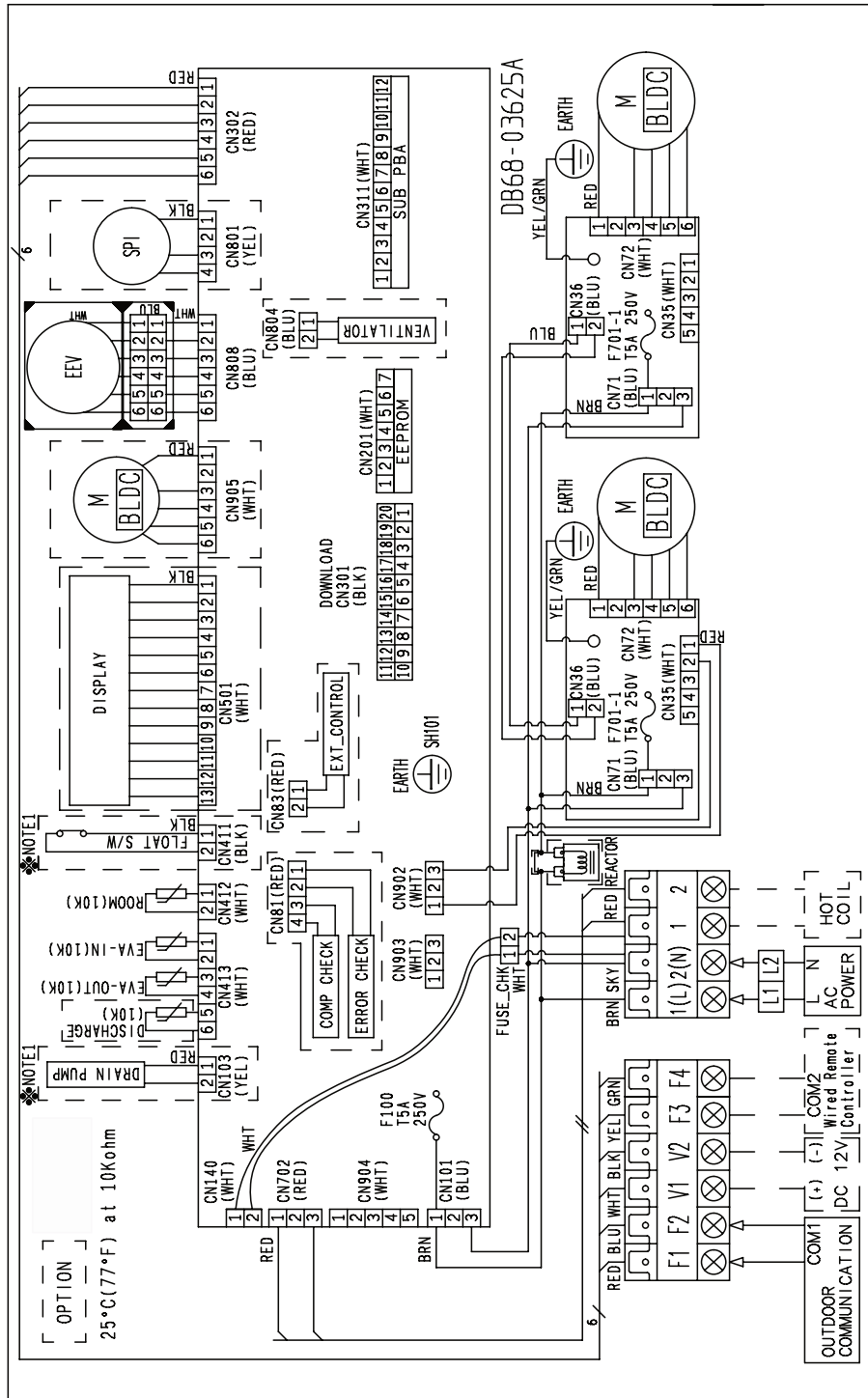

Figure 3. Dimensional drawing for 36, 42, and 48 MBH capacity units



4MUD4530A10N0A, 4MUD4536A10N0A, 4MUD4542A10N0A and 4MUD4548A10N0A





Wiring Diagrams

Outdoor Unit

4TUK4518A10N0A

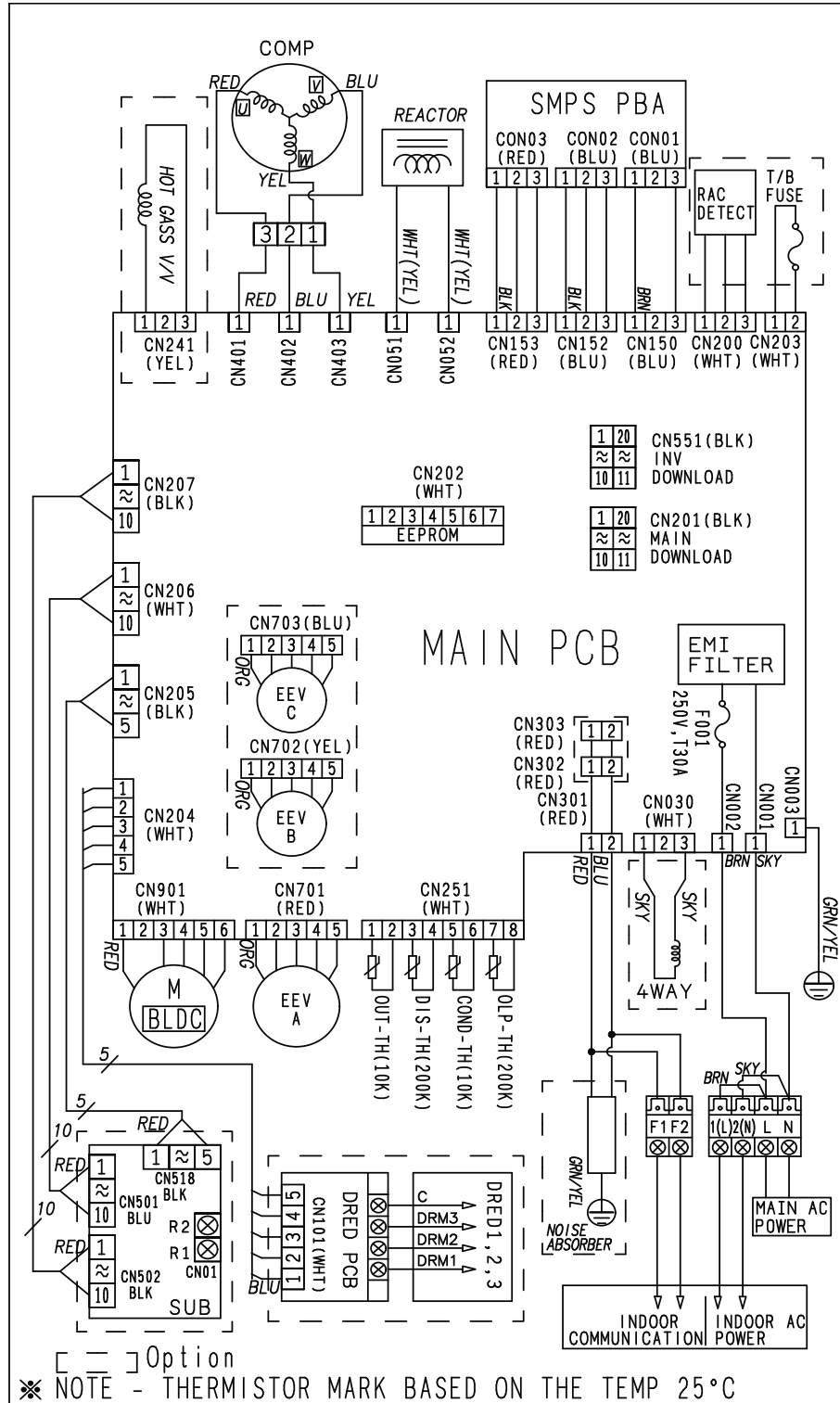

4TUK4524A10N0A, 4TUK4530A10N0A, 4TUK4536A10N0A, 4TUK4542A10N0A, and 4TUK4548A10N0A

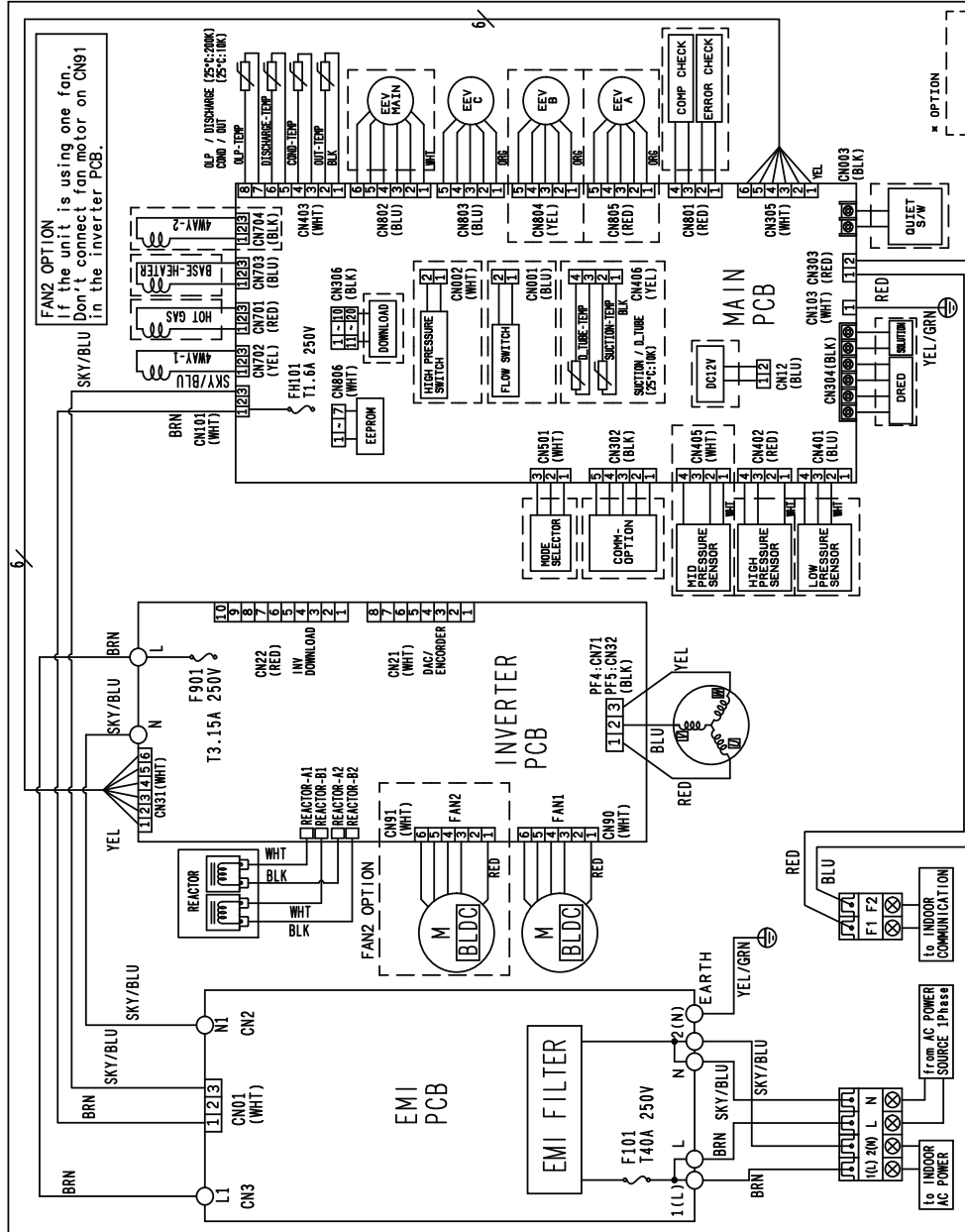



Sound Levels

Indoor Unit

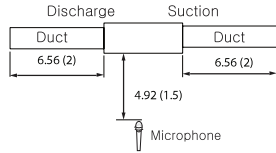

Unit: ft (m)

Model		High	Low
Indoor	Outdoor	dBA	
4MUD4518A10N0A	4TUK4518A10N0A	34.0	26.0
4MUD4524A10N0A	4TUK4524A10N0A	36.0	28.0
4MUD4530A10N0A	4TUK4530A10N0A	37.0	29.0
4MUD4536A10N0A	4TUK4536A10N0A	37.0	30.0
4MUD4542A10N0A	4TUK4542A10N0A	40.0	34.0
4MUD4548A10N0A	4TUK4548A10N0A	43.0	37.0

Notes:

- These operation values were obtained in an anechoic room. Sound pressure level will vary depending on a range of factors such as the construction of the particular room where the equipment is installed.
- Operation sound level may differ depending on operation and ambient conditions.

4MUD4518A10N0A (ODU: 4TUK4518A10N0A)

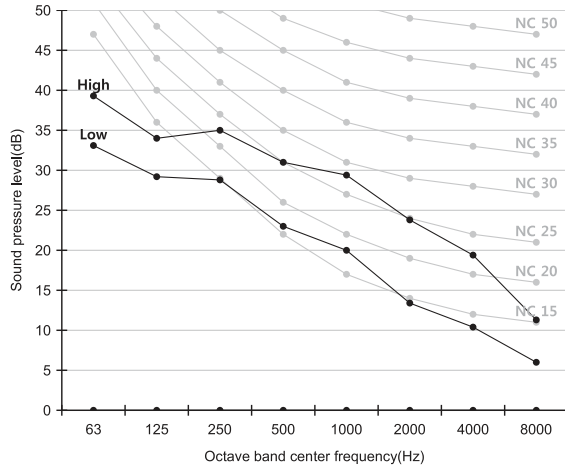

4MUD4524A10N0A (ODU: 4TUK4524A10N0A)

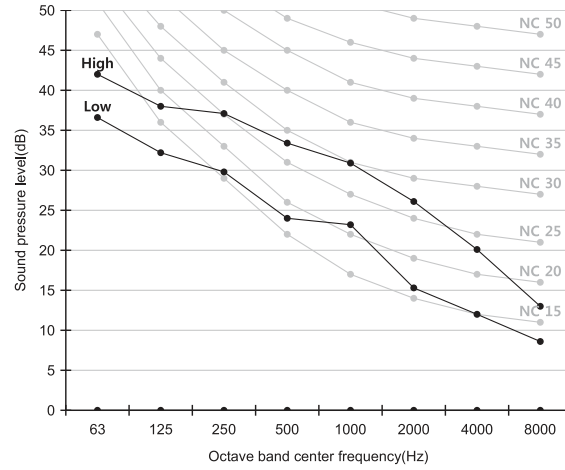

4MUD4530A10N0A (ODU: 4TUK4530A10N0A)

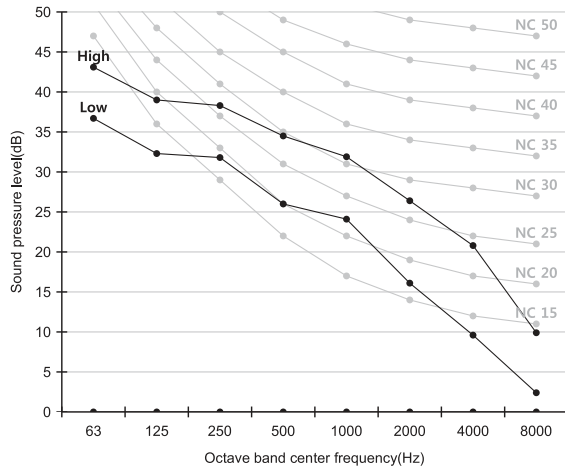

4MUD4536A10N0A (ODU: 4TUK4536A10N0A)

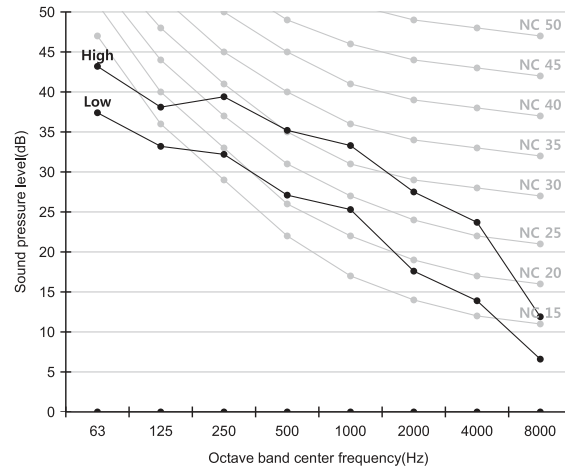

4MUD4542A10N0A (ODU: 4TUK4542A10N0A)

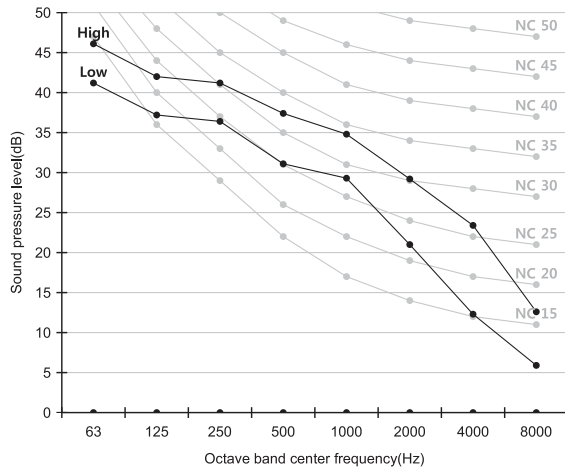

4MUD4548A10N0A (ODU: 4TUK4548A10N0A)

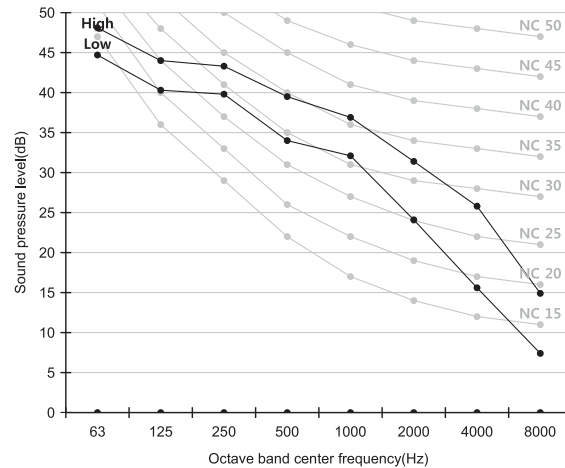



Sound Levels

Outdoor Unit

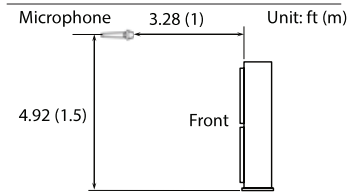

Model		Cooling	Heating
Indoor	Outdoor	dBA	
4MUD4518A10N0A	4TUK4518A10N0A	48.0	48.0
4MUD4524A10N0A	4TUK4524A10N0A	50.0	50.0
4MUD4530A10N0A	4TUK4530A10N0A	50.0	52.0
4MUD4536A10N0A	4TUK4536A10N0A	49.0	51.0
4MUD4542A10N0A	4TUK4542A10N0A	51.0	53.0
4MUD4548A10N0A	4TUK4548A10N0A	53.0	55.0

NC Curve

4TUK4518A10N0A (IDU: 4MUD4518A10N0A)

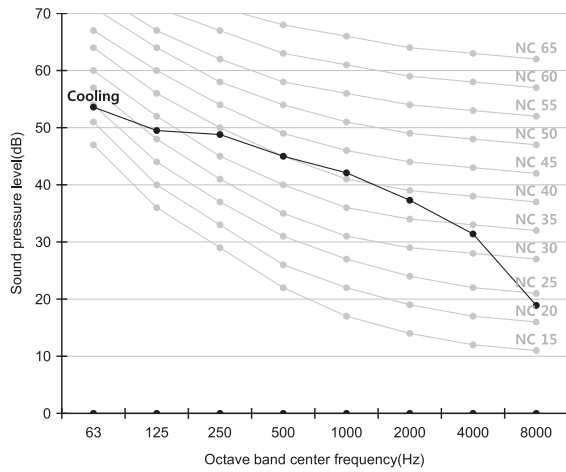

4TUK4524A10N0A (IDU: 4MUD4524A10N0A)

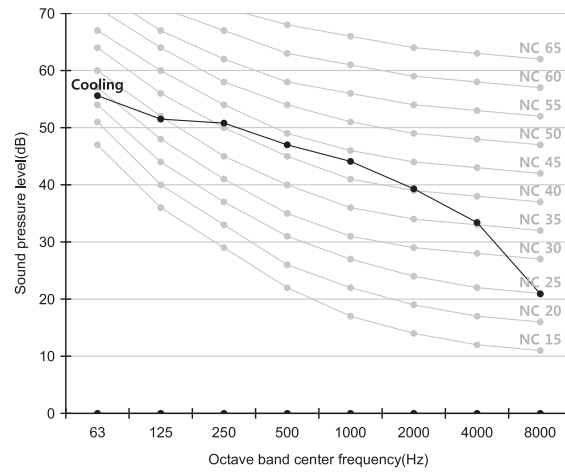

4TUK4530A10N0A (IDU: 4MUD4530A10N0A)

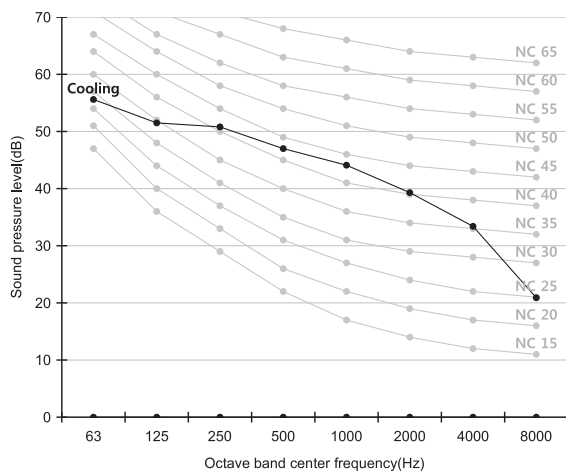

4TUK4536A10N0A (IDU: 4MUD4536A10N0A)

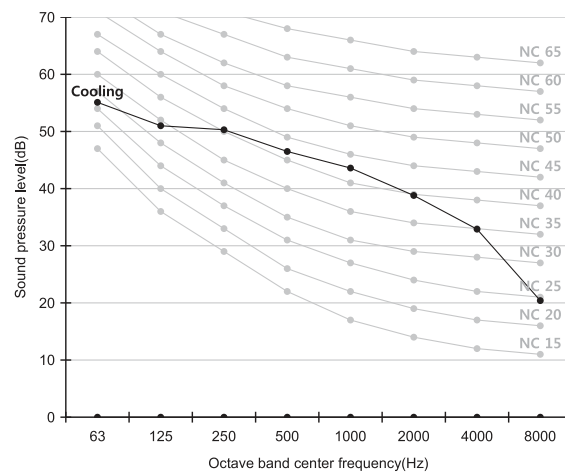

4TUK4542A10N0A (IDU: 4MUD4542A10N0A)

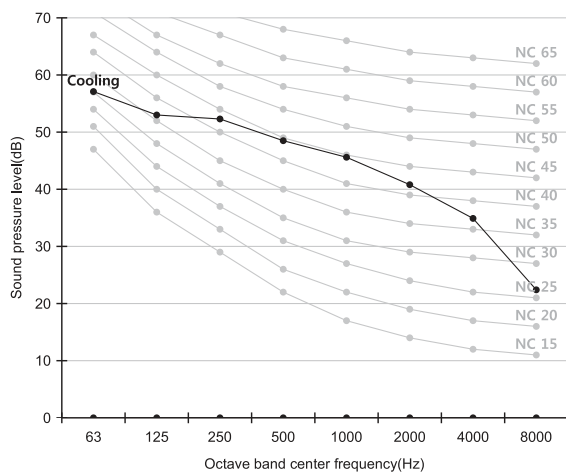

4TUK4548A10N0A (IDU: 4MUD4548A10N0A)

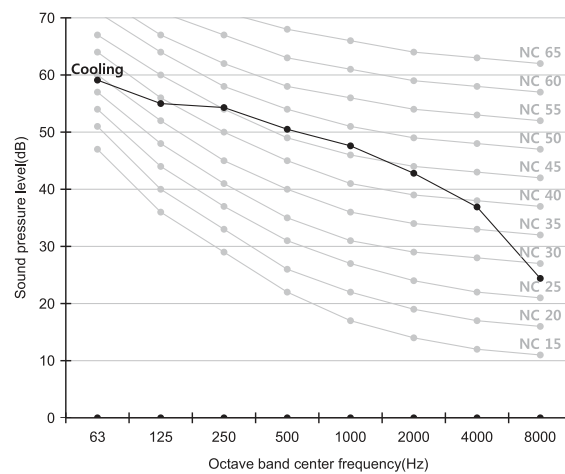

Airflow Diagrams

How to Interpret P-Q Tables and Graphs

The following figure shows an example of how to interpret the P-Q curve tables and graphs. Each box represents a static pressure range setpoint and shows its specific fan curve. Point 3 represents the highest available static pressure for each specific setting. When the fan is set to Auto, the fan tracks from right to left within the box.

Figure 4. P-Q Curve Example

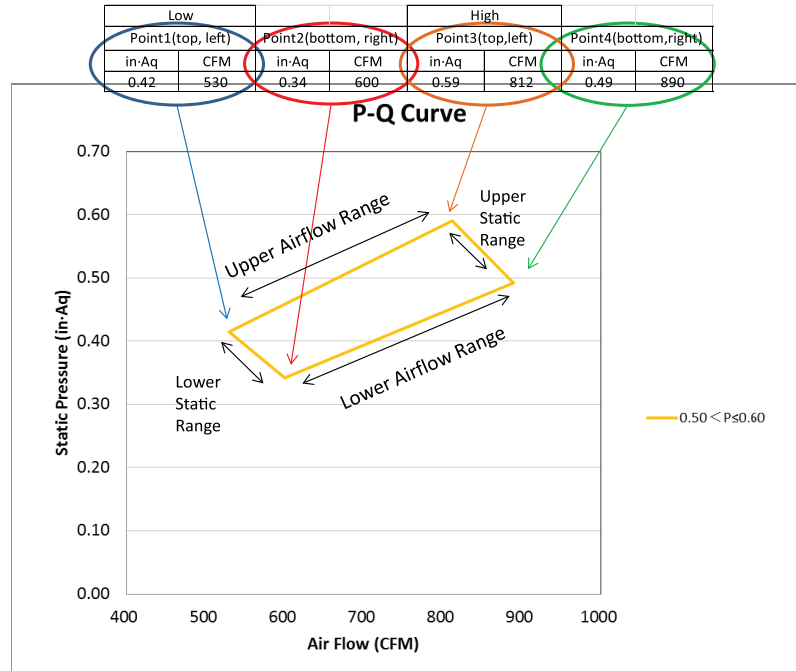

4MUD4518A10N0A

P-Q data	Low		Point 2 (bottom, left)		High		Point 4 (bottom, right)	
	Point 1 (top, left)		Point 2 (bottom, left)		Point 3 (top, right)		Point 4 (bottom, right)	
	in·Aq	CFM	in·Aq	CFM	in·Aq	CFM	in·Aq	CFM
$0 \leq P \leq 0.12$ (Default)	0.05	406	0.01	452	0.12	639	0.06	689
$0.12 < P \leq 0.20$	0.11	403	0.05	452	0.20	639	0.12	692
$0.20 < P \leq 0.30$	0.18	403	0.10	452	0.30	639	0.20	696
$0.30 < P \leq 0.40$	0.26	403	0.18	452	0.39	639	0.30	696
$0.40 < P \leq 0.50$	0.33	403	0.25	452	0.49	639	0.39	696
$0.50 < P \leq 0.60$	0.41	403	0.33	452	0.59	639	0.49	696

Figure 5. 4MUD4518A10N0A P-Q Curve Example

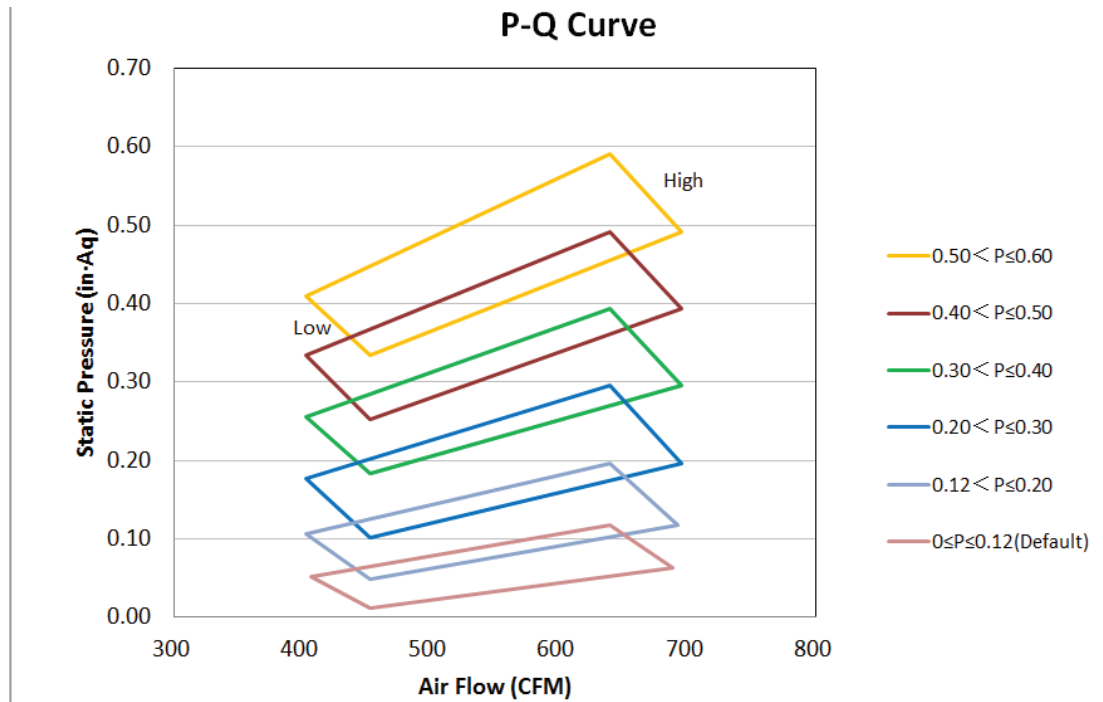

4MUD4524A10N0A

P-Q data	Low				High			
	Point 1 (top, left)		Point 2 (bottom, left)		Point 3 (top, right)		Point 4 (bottom, right)	
	in·Aq	CFM	in·Aq	CFM	in·Aq	CFM	in·Aq	CFM
$0 \leq P \leq 0.12$	0.05	537	0.02	593	0.12	819	0.07	883
$0.12 < P \leq 0.20$	0.11	533	0.05	600	0.20	819	0.12	890
$0.20 < P \leq 0.30$	0.18	533	0.10	597	0.30	819	0.20	890
$0.30 < P \leq 0.40$	0.26	533	0.18	600	0.39	819	0.30	890
$0.40 < P \leq 0.50$	0.34	533	0.25	600	0.49	819	0.39	890
$0.50 < P \leq 0.60$	0.42	530	0.34	600	0.59	812	0.49	890

Figure 6. 4MUD4524A10N0A P-Q Curve Example

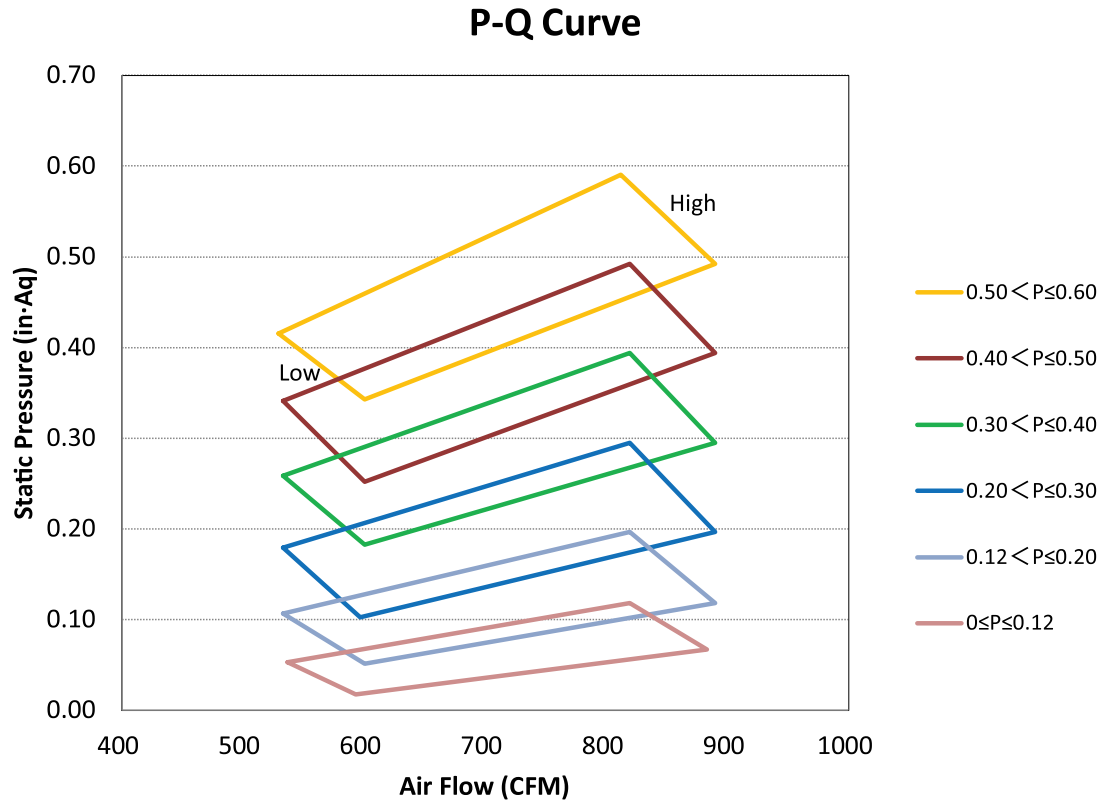

4MUD4530A10N0A

P-Q data	Low				High			
	Point 1 (top, left)		Point 2 (bottom, left)		Point 3 (top, right)		Point 4 (bottom, right)	
	in·Aq	CFM	in·Aq	CFM	in·Aq	CFM	in·Aq	CFM
0.12 ≤ P ≤ 0.16 (Default)	0.07	749	0.02	805	0.16	1049	0.08	1112
0.16 < P ≤ 0.28	0.15	749	0.07	812	0.28	1042	0.16	1112
0.28 < P ≤ 0.40	0.24	742	0.15	812	0.39	1042	0.28	1112
0.40 < P ≤ 0.50	0.31	742	0.24	812	0.49	1042	0.39	1112
0.50 < P ≤ 0.60	0.38	742	0.32	812	0.59	1042	0.49	1112
0.60 < P ≤ 0.70	0.45	742	0.38	812	0.69	1042	0.59	1112
0.70 < P ≤ 0.80	0.53	742	0.46	812	0.79	1042	0.69	1112

Figure 7. 4MUD4530A10N0A P-Q Curve Example

P-Q Curve

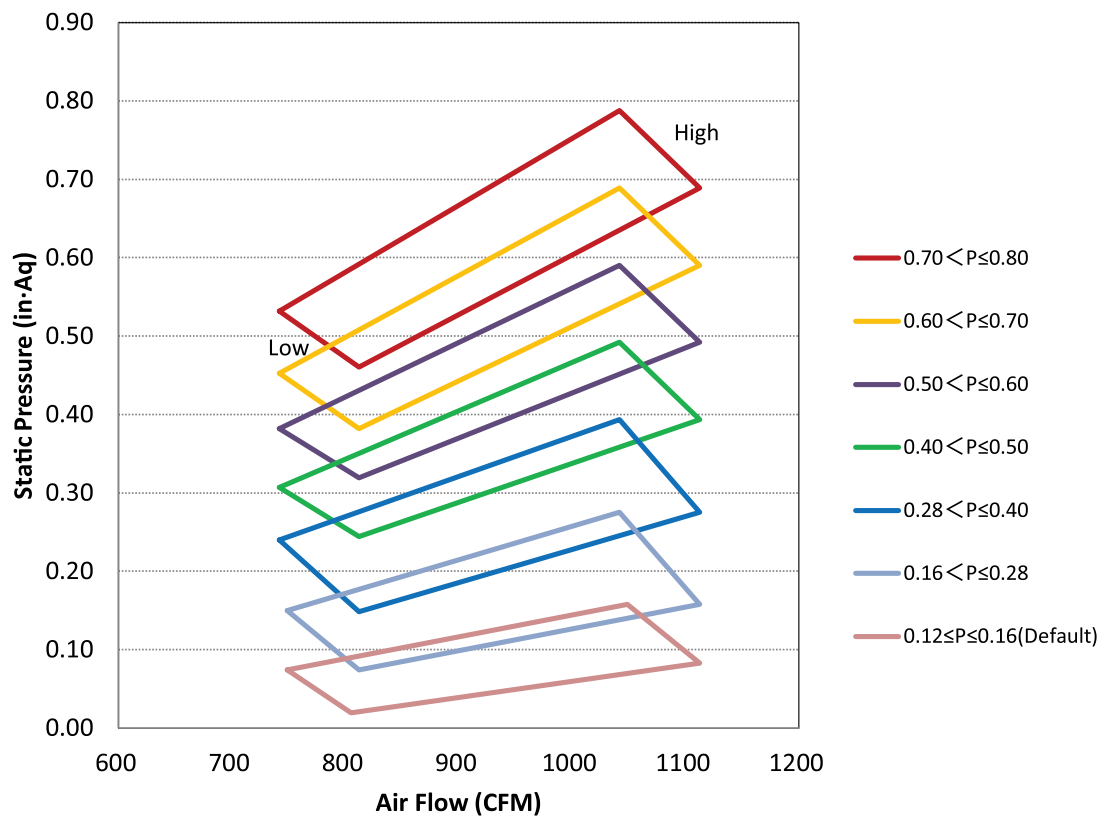

4MUD4536A10N0A

P-Q data	Low				High			
	Point 1 (top, left)		Point 2 (bottom, right)		Point 3 (top, left)		Point 4 (bottom, right)	
	in·Aq	CFM	in·Aq	CFM	in·Aq	CFM	in·Aq	CFM
$0.12 \leq P \leq 0.16$	0.07	749	0.02	823	0.16	1201	0.08	1278
$0.16 < P \leq 0.28$	0.13	742	0.07	823	0.28	1201	0.16	1296
$0.28 < P \leq 0.40$	0.20	742	0.13	823	0.39	1201	0.28	1296
$0.40 < P \leq 0.50$	0.26	742	0.20	823	0.49	1201	0.39	1296
$0.50 < P \leq 0.60$	0.33	742	0.26	823	0.59	1201	0.49	1296
$0.60 < P \leq 0.70$	0.41	742	0.33	823	0.69	1201	0.59	1296
$0.70 < P \leq 0.80$	0.48	742	0.41	823	0.79	1194	0.69	1296

Figure 8. 4MUD4536A10N0A P-Q Curve Example

P-Q Curve

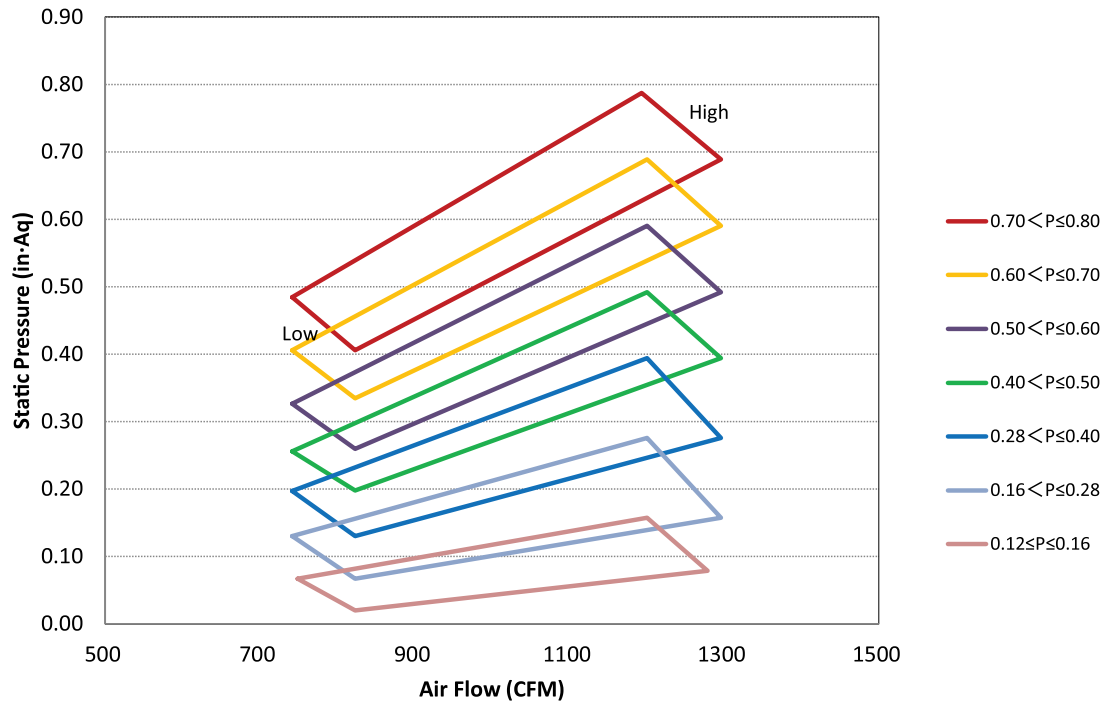

4MUD4542A10N0A

P-Q data	Low				High			
	Point 1 (top, left)		Point 2 (bottom, left)		Point 3 (top, right)		Point 4 (bottom, right)	
	in·Aq	CFM	in·Aq	CFM	in·Aq	CFM	in·Aq	CFM
$0.16 \leq P \leq 0.20$	0.12	1148	0.06	1233	0.20	1459	0.13	1547
$0.20 < P \leq 0.30$	0.18	1148	0.12	1236	0.30	1459	0.20	1561
$0.30 < P \leq 0.40$	0.25	1148	0.19	1236	0.39	1459	0.30	1554
$0.40 < P \leq 0.50$	0.31	1148	0.25	1236	0.49	1459	0.39	1561
$0.50 < P \leq 0.60$	0.37	1148	0.32	1236	0.59	1459	0.49	1561
$0.60 < P \leq 0.70$	0.45	1148	0.39	1236	0.69	1459	0.59	1561
$0.70 < P \leq 0.80$	0.53	1148	0.46	1236	0.79	1448	0.69	1561

Figure 9. 4MUD4542A10N0A P-Q Curve Example

P-Q Curve

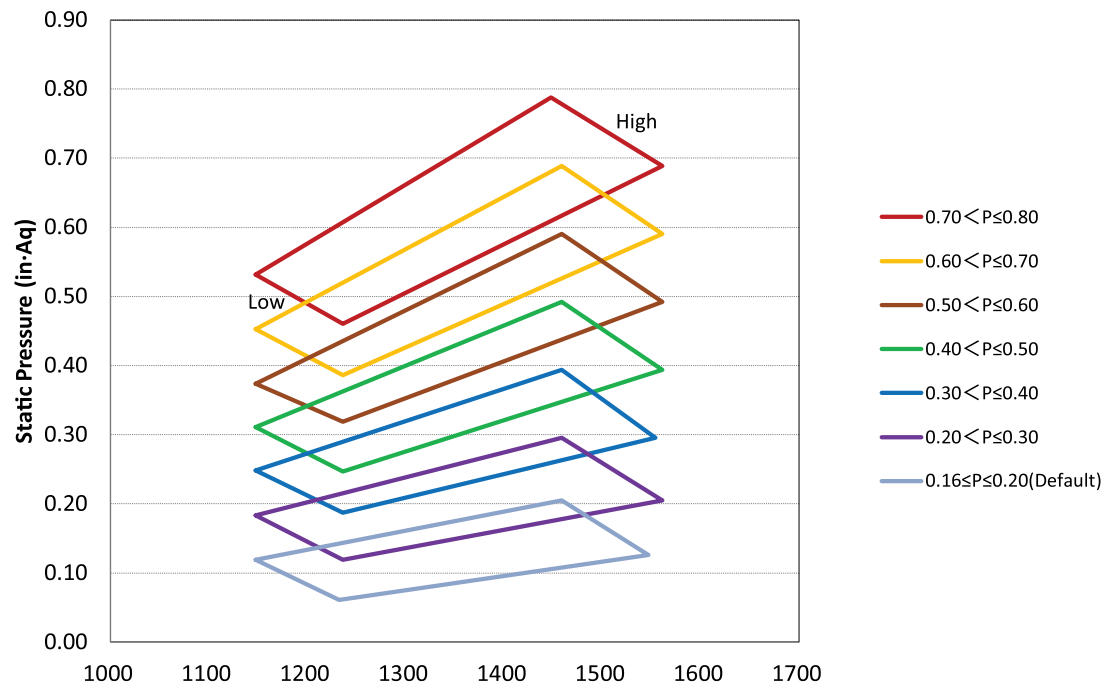

4MUD4548A10N0A

P-Q data	Low				High			
	Point 1 (top, left)		Point 2 (bottom, left)		Point 3 (top, right)		Point 4 (bottom, right)	
	in·Aq	CFM	in·Aq	CFM	in·Aq	CFM	in·Aq	CFM
$0.16 \leq P \leq 0.20$	0.11	1197	0.05	1289	0.20	1621	0.13	1723
$0.20 < P \leq 0.30$	0.17	1190	0.11	1289	0.30	1621	0.20	1723
$0.30 < P \leq 0.40$	0.25	1190	0.17	1289	0.39	1621	0.30	1723
$0.40 < P \leq 0.50$	0.32	1190	0.25	1289	0.49	1621	0.39	1723
$0.50 < P \leq 0.60$	0.39	1190	0.32	1289	0.59	1621	0.49	1723
$0.60 < P \leq 0.70$	0.46	1190	0.39	1289	0.69	1621	0.59	1723
$0.70 < P \leq 0.80$	0.55	1190	0.46	1289	0.79	1621	0.69	1723





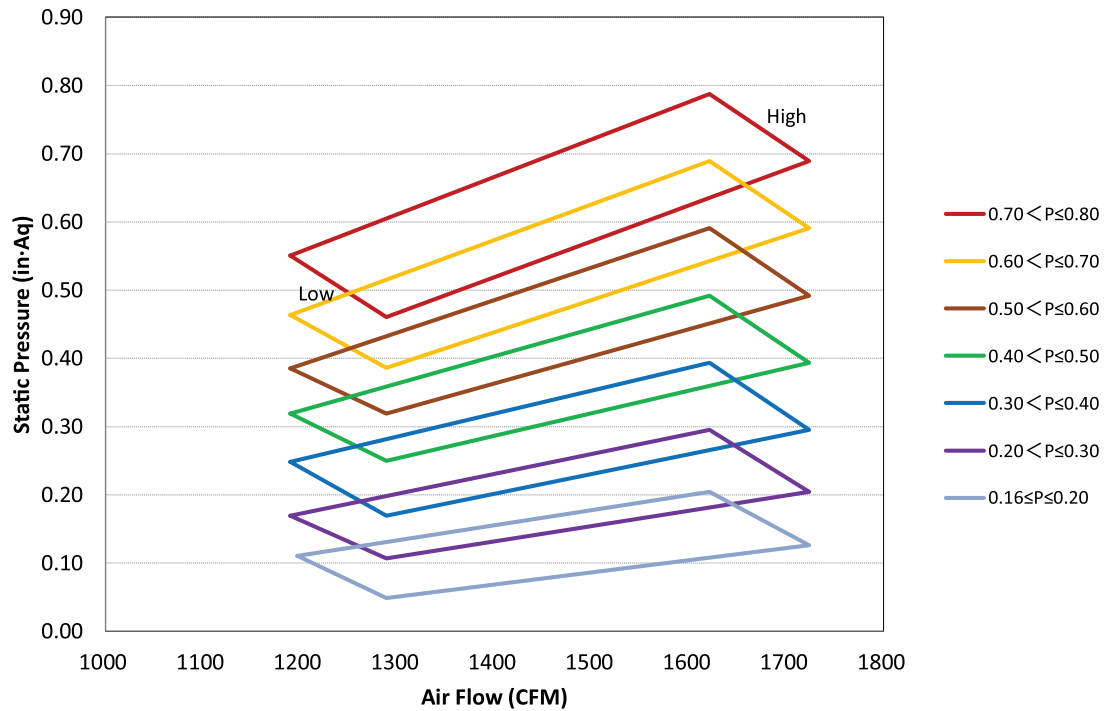

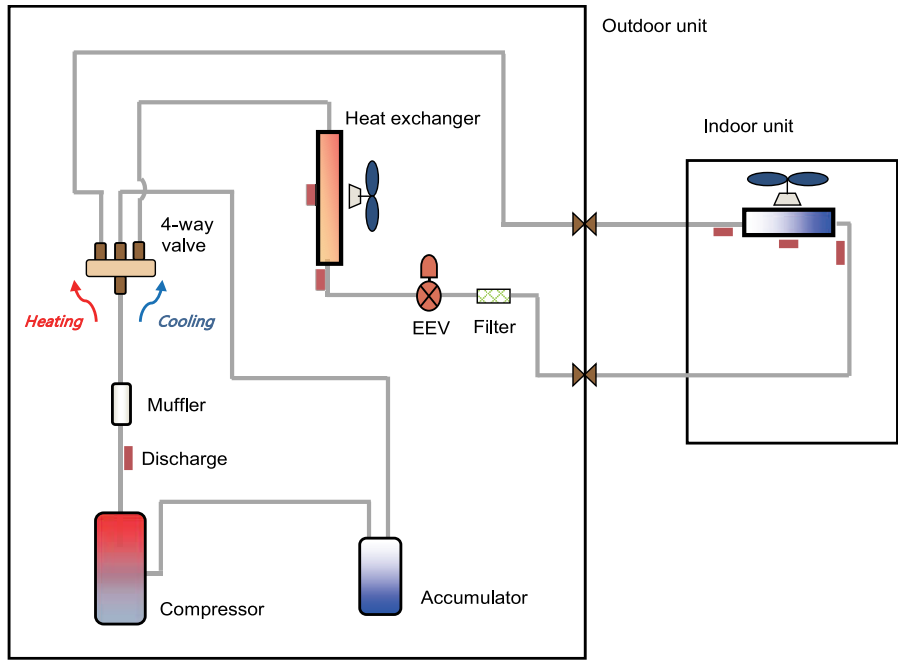

Figure 10. 4MUD4548A10N0A P-Q Curve Example

P-Q Curve



Refrigerant Cycle Diagram



Category	Symbol	Description
Compressor		Rotary inverter compressor
Heat exchanger		Condensing/evaporating unit
Accumulator		Accumulator
Filter		Filter
Valve	Expansion 	Electronic expansion valve (EEV)
	Reversing 	4-way valve (reversing valve)
	Service 	Service valve
Sensor	Temperature 	Pipe/air temperature sensor



Capacity Correction Tables

4MUD4518A10N0A and 4TUK4518A10N0A

Cooling

Level Difference (ft)	Pipe length (ft)					
	16.4	32.8	49.2	65.6	82	98.4
65.6	—	—	—	0.96	0.94	0.93
49.2	—	—	0.97	0.96	0.94	0.93
32.8	—	0.99	0.97	0.96	0.94	0.93
16.4	1.00	0.99	0.97	0.96	0.94	0.93
0.0	1.00	0.99	0.97	0.96	0.94	0.93
-16.4	1.00	0.98	0.97	0.95	0.94	0.93
-32.8	—	0.97	0.96	0.95	0.93	0.92
-49.2	—	—	0.96	0.94	0.93	0.92
-65.6	—	—	—	0.94	0.92	0.91

Heating

Level Difference (ft)	Pipe length (ft)					
	16.4	32.8	49.2	65.6	82	98.4
65.6	—	—	—	0.94	0.92	0.90
49.2	—	—	0.96	0.94	0.92	0.90
32.8	—	0.98	0.96	0.94	0.92	0.90
16.4	1.00	0.98	0.96	0.94	0.92	0.90
0.0	1.00	0.98	0.96	0.94	0.92	0.90
-16.4	1.00	0.98	0.96	0.94	0.92	0.90
-32.8	—	0.98	0.96	0.94	0.92	0.90
-49.2	—	—	0.96	0.94	0.92	0.90
-65.6	—	—	—	0.94	0.92	0.90

4MUD4524A10N0A and 4TUK4524A10N0A

Cooling

Level Difference (ft)	Pipe length (ft)									
	16.4	32.8	49.2	65.6	82	98.4	114.8	131.2	147.6	164.0
98.4	—	—	—	—	—	0.94	0.93	0.92	0.91	0.90
82.0	—	—	—	—	0.96	0.94	0.93	0.92	0.91	0.90
65.6	—	—	—	0.97	0.96	0.94	0.93	0.92	0.91	0.90
49.2	—	—	0.98	0.97	0.96	0.94	0.93	0.92	0.91	0.90
32.8	—	0.99	0.98	0.97	0.96	0.94	0.93	0.92	0.91	0.90
16.4	1.00	0.99	0.98	0.97	0.96	0.94	0.93	0.92	0.91	0.90
0.0	1.00	0.99	0.98	0.97	0.96	0.94	0.93	0.92	0.91	0.90
-16.4	1.00	0.98	0.97	0.96	0.95	0.94	0.93	0.92	0.90	0.88
-32.8	—	0.98	0.97	0.96	0.95	0.94	0.92	0.91	0.89	0.87
-49.2	—	—	0.97	0.96	0.94	0.93	0.92	0.90	0.88	0.85
-65.6	—	—	—	0.95	0.94	0.93	0.91	0.89	0.87	0.83
-82.0	—	—	—	—	0.94	0.92	0.91	0.89	0.86	0.82
-98.4	—	—	—	—	—	0.92	0.90	0.88	0.85	0.80

Heating

Level Difference (ft)	Pipe length (ft)									
	16.4	32.8	49.2	65.6	82	98.4	114.8	131.2	147.6	164.0
98.4	—	—	—	—	—	0.94	0.93	0.92	0.91	0.90
82.0	—	—	—	—	0.96	0.94	0.93	0.92	0.91	0.90
65.6	—	—	—	0.97	0.96	0.94	0.93	0.92	0.91	0.90
49.2	—	—	0.98	0.97	0.96	0.94	0.93	0.92	0.91	0.90
32.8	—	0.99	0.98	0.97	0.96	0.94	0.93	0.92	0.91	0.90
16.4	1.00	0.99	0.98	0.97	0.96	0.94	0.93	0.92	0.91	0.90
0.0	1.00	0.99	0.98	0.97	0.96	0.94	0.93	0.92	0.91	0.90
-16.4	1.00	0.99	0.98	0.97	0.96	0.94	0.93	0.92	0.91	0.90
-32.8	—	0.99	0.98	0.97	0.96	0.94	0.93	0.92	0.91	0.90
-49.2	—	—	0.98	0.97	0.96	0.94	0.93	0.92	0.91	0.90
-65.6	—	—	—	0.97	0.96	0.94	0.93	0.92	0.91	0.90
-82.0	—	—	—	—	0.96	0.94	0.93	0.92	0.91	0.90
-98.4	—	—	—	—	—	0.94	0.93	0.92	0.91	0.90



Capacity Correction Tables

4MUD4530A10N0A and 4TUK4530A10N0A

Cooling

Level Difference (ft)	Pipe length (ft)									
	16.4	32.8	49.2	65.6	82	98.4	114.8	131.2	147.6	164.0
98.4	—	—	—	—	—	0.94	0.93	0.92	0.91	0.90
82.0	—	—	—	—	0.96	0.94	0.93	0.92	0.91	0.90
65.6	—	—	—	0.97	0.96	0.94	0.93	0.92	0.91	0.90
49.2	—	—	0.98	0.97	0.96	0.94	0.93	0.92	0.91	0.90
32.8	—	0.99	0.98	0.97	0.96	0.94	0.93	0.92	0.91	0.90
16.4	1.00	0.99	0.98	0.97	0.96	0.94	0.93	0.92	0.91	0.90
0.0	1.00	0.99	0.98	0.97	0.96	0.94	0.93	0.92	0.91	0.90
-16.4	1.00	0.98	0.97	0.96	0.95	0.94	0.93	0.92	0.90	0.88
-32.8	—	0.98	0.97	0.96	0.95	0.94	0.92	0.91	0.89	0.87
-49.2	—	—	0.97	0.96	0.94	0.93	0.92	0.90	0.88	0.85
-65.6	—	—	—	0.95	0.94	0.93	0.91	0.89	0.87	0.83
-82.0	—	—	—	—	0.94	0.92	0.91	0.89	0.86	0.82
-98.4	—	—	—	—	—	0.92	0.90	0.88	0.85	0.80

Heating

Level Difference (ft)	Pipe length (ft)									
	16.4	32.8	49.2	65.6	82	98.4	114.8	131.2	147.6	164.0
98.4	—	—	—	—	—	0.94	0.93	0.92	0.91	0.90
82.0	—	—	—	—	0.96	0.94	0.93	0.92	0.91	0.90
65.6	—	—	—	0.97	0.96	0.94	0.93	0.92	0.91	0.90
49.2	—	—	0.98	0.97	0.96	0.94	0.93	0.92	0.91	0.90
32.8	—	0.99	0.98	0.97	0.96	0.94	0.93	0.92	0.91	0.90
16.4	1.00	0.99	0.98	0.97	0.96	0.94	0.93	0.92	0.91	0.90
0.0	1.00	0.99	0.98	0.97	0.96	0.94	0.93	0.92	0.91	0.90
-16.4	1.00	0.99	0.98	0.97	0.96	0.94	0.93	0.92	0.91	0.90
-32.8	—	0.99	0.98	0.97	0.96	0.94	0.93	0.92	0.91	0.90
-49.2	—	—	0.98	0.97	0.96	0.94	0.93	0.92	0.91	0.90
-65.6	—	—	—	0.97	0.96	0.94	0.93	0.92	0.91	0.90
-82.0	—	—	—	—	0.96	0.94	0.93	0.92	0.91	0.90
-98.4	—	—	—	—	—	0.94	0.93	0.92	0.91	0.90

4MUD4536A10N0A and 4TUK4536A10N0A

Cooling

Level Difference (ft)	Pipe length (ft)														
	16.4	32.8	49.2	65.6	82	98.4	114.8	131.2	147.6	164.0	180.4	196.9	213.3	229.7	246.1
98.4	—	—	—	—	—	0.96	0.95	0.94	0.93	0.92	0.91	0.91	0.90	0.89	0.88
82.0	—	—	—	—	0.97	0.96	0.95	0.94	0.93	0.92	0.91	0.91	0.90	0.89	0.88
65.6	—	—	—	0.97	0.97	0.96	0.95	0.94	0.93	0.92	0.91	0.91	0.90	0.89	0.88
49.2	—	—	0.98	0.97	0.97	0.96	0.95	0.94	0.93	0.92	0.91	0.91	0.90	0.89	0.88
32.8	—	0.99	0.98	0.97	0.97	0.96	0.95	0.94	0.93	0.92	0.91	0.91	0.90	0.89	0.88
16.4	1.00	0.99	0.98	0.97	0.97	0.96	0.95	0.94	0.93	0.92	0.91	0.91	0.90	0.89	0.88
0.0	1.00	0.99	0.98	0.97	0.97	0.96	0.95	0.94	0.93	0.92	0.91	0.91	0.90	0.89	0.88
-16.4	1.00	0.99	0.98	0.97	0.96	0.95	0.95	0.94	0.93	0.92	0.91	0.90	0.89	0.88	0.87
-32.8	—	0.98	0.98	0.97	0.96	0.95	0.94	0.93	0.93	0.92	0.91	0.90	0.89	0.87	0.85
-49.2	—	—	0.97	0.97	0.96	0.95	0.94	0.93	0.92	0.91	0.90	0.89	0.88	0.86	0.84
-65.6	—	—	—	0.96	0.95	0.95	0.94	0.93	0.92	0.91	0.90	0.89	0.88	0.86	0.83
-82.0	—	—	—	—	0.95	0.94	0.93	0.93	0.92	0.91	0.90	0.88	0.87	0.85	0.81
-98.4	—	—	—	—	—	0.94	0.93	0.92	0.91	0.90	0.89	0.88	0.86	0.84	0.80

Heating

Level Difference (ft)	Pipe length (ft)														
	16.4	32.8	49.2	65.6	82	98.4	114.8	131.2	147.6	164.0	180.4	196.9	213.3	229.7	246.1
98.4	—	—	—	—	—	0.96	0.95	0.94	0.93	0.92	0.91	0.91	0.90	0.89	0.88
82.0	—	—	—	—	0.97	0.96	0.95	0.94	0.93	0.92	0.91	0.91	0.90	0.89	0.88
65.6	—	—	—	0.97	0.97	0.96	0.95	0.94	0.93	0.92	0.91	0.91	0.90	0.89	0.88
49.2	—	—	0.98	0.97	0.97	0.96	0.95	0.94	0.93	0.92	0.91	0.91	0.90	0.89	0.88
32.8	—	0.99	0.98	0.97	0.97	0.96	0.95	0.94	0.93	0.92	0.91	0.91	0.90	0.89	0.88
16.4	1.00	0.99	0.98	0.97	0.97	0.96	0.95	0.94	0.93	0.92	0.91	0.91	0.90	0.89	0.88
0.0	1.00	0.99	0.98	0.97	0.97	0.96	0.95	0.94	0.93	0.92	0.91	0.91	0.90	0.89	0.88
-16.4	1.00	0.99	0.98	0.97	0.97	0.96	0.95	0.94	0.93	0.92	0.91	0.91	0.90	0.88	0.88
-32.8	—	0.99	0.98	0.97	0.97	0.96	0.95	0.94	0.93	0.92	0.91	0.91	0.90	0.89	0.88
-49.2	—	—	0.98	0.97	0.97	0.96	0.95	0.94	0.93	0.92	0.91	0.91	0.90	0.89	0.88
-65.6	—	—	—	0.97	0.97	0.96	0.95	0.94	0.93	0.92	0.91	0.91	0.90	0.89	0.88
-82.0	—	—	—	—	0.97	0.96	0.95	0.94	0.93	0.92	0.91	0.91	0.90	0.89	0.88
-98.4	—	—	—	—	—	0.96	0.95	0.94	0.93	0.92	0.91	0.91	0.90	0.89	0.88



Capacity Correction Tables

4MUD4542A10N0A and 4TUK4542A10N0A

Cooling

Level Difference (ft)	Pipe length (ft)														
	16.4	32.8	49.2	65.6	82	98.4	114.8	131.2	147.6	164.0	180.4	196.9	213.3	229.7	246.1
98.4	—	—	—	—	—	0.96	0.95	0.94	0.93	0.92	0.91	0.91	0.90	0.89	0.88
82.0	—	—	—	—	0.97	0.96	0.95	0.94	0.93	0.92	0.91	0.91	0.90	0.89	0.88
65.6	—	—	—	0.97	0.97	0.96	0.95	0.94	0.93	0.92	0.91	0.91	0.90	0.89	0.88
49.2	—	—	0.98	0.97	0.97	0.96	0.95	0.94	0.93	0.92	0.91	0.91	0.90	0.89	0.88
32.8	—	0.99	0.98	0.97	0.97	0.96	0.95	0.94	0.93	0.92	0.91	0.91	0.90	0.89	0.88
16.4	1.00	0.99	0.98	0.97	0.97	0.96	0.95	0.94	0.93	0.92	0.91	0.91	0.90	0.89	0.88
0.0	1.00	0.99	0.98	0.97	0.97	0.96	0.95	0.94	0.93	0.92	0.91	0.91	0.90	0.89	0.88
-16.4	1.00	0.99	0.98	0.97	0.96	0.95	0.95	0.94	0.93	0.92	0.91	0.90	0.89	0.88	0.87
-32.8	—	0.98	0.98	0.97	0.96	0.95	0.94	0.93	0.93	0.92	0.91	0.90	0.89	0.87	0.85
-49.2	—	—	0.97	0.97	0.96	0.95	0.94	0.93	0.92	0.91	0.90	0.89	0.88	0.86	0.84
-65.6	—	—	—	0.96	0.95	0.95	0.94	0.93	0.92	0.91	0.90	0.89	0.88	0.86	0.83
-82.0	—	—	—	—	0.95	0.94	0.93	0.93	0.92	0.91	0.90	0.88	0.87	0.85	0.81
-98.4	—	—	—	—	—	0.94	0.93	0.92	0.91	0.90	0.89	0.88	0.86	0.84	0.80

Heating

Level Difference (ft)	Pipe length (ft)														
	16.4	32.8	49.2	65.6	82	98.4	114.8	131.2	147.6	164.0	180.4	196.9	213.3	229.7	246.1
98.4	—	—	—	—	—	0.96	0.95	0.94	0.93	0.92	0.91	0.91	0.90	0.89	0.88
82.0	—	—	—	—	0.97	0.96	0.95	0.94	0.93	0.92	0.91	0.91	0.90	0.89	0.88
65.6	—	—	—	0.97	0.97	0.96	0.95	0.94	0.93	0.92	0.91	0.91	0.90	0.89	0.88
49.2	—	—	0.98	0.97	0.97	0.96	0.95	0.94	0.93	0.92	0.91	0.91	0.90	0.89	0.88
32.8	—	0.99	0.98	0.97	0.97	0.96	0.95	0.94	0.93	0.92	0.91	0.91	0.90	0.89	0.88
16.4	1.00	0.99	0.98	0.97	0.97	0.96	0.95	0.94	0.93	0.92	0.91	0.91	0.90	0.89	0.88
0.0	1.00	0.99	0.98	0.97	0.97	0.96	0.95	0.94	0.93	0.92	0.91	0.91	0.90	0.89	0.88
-16.4	1.00	0.99	0.98	0.97	0.97	0.96	0.95	0.94	0.93	0.92	0.91	0.91	0.90	0.88	0.88
-32.8	—	0.99	0.98	0.97	0.97	0.96	0.95	0.94	0.93	0.92	0.91	0.91	0.90	0.89	0.88
-49.2	—	—	0.98	0.97	0.97	0.96	0.95	0.94	0.93	0.92	0.91	0.91	0.90	0.89	0.88
-65.6	—	—	—	0.97	0.97	0.96	0.95	0.94	0.93	0.92	0.91	0.91	0.90	0.89	0.88
-82.0	—	—	—	—	0.97	0.96	0.95	0.94	0.93	0.92	0.91	0.91	0.90	0.89	0.88
-98.4	—	—	—	—	—	0.96	0.95	0.94	0.93	0.92	0.91	0.91	0.90	0.89	0.88

4MUD4548A10N0A and 4TUK4548A10N0A

Cooling

Level Difference (ft)	Pipe length (ft)														
	16.4	32.8	49.2	65.6	82	98.4	114.8	131.2	147.6	164.0	180.4	196.9	213.3	229.7	246.1
98.4	—	—	—	—	—	0.96	0.95	0.94	0.93	0.92	0.91	0.91	0.90	0.89	0.88
82.0	—	—	—	—	0.97	0.96	0.95	0.94	0.93	0.92	0.91	0.91	0.90	0.89	0.88
65.6	—	—	—	0.97	0.97	0.96	0.95	0.94	0.93	0.92	0.91	0.91	0.90	0.89	0.88
49.2	—	—	0.98	0.97	0.97	0.96	0.95	0.94	0.93	0.92	0.91	0.91	0.90	0.89	0.88
32.8	—	0.99	0.98	0.97	0.97	0.96	0.95	0.94	0.93	0.92	0.91	0.91	0.90	0.89	0.88
16.4	1.00	0.99	0.98	0.97	0.97	0.96	0.95	0.94	0.93	0.92	0.91	0.91	0.90	0.89	0.88
0.0	1.00	0.99	0.98	0.97	0.97	0.96	0.95	0.94	0.93	0.92	0.91	0.91	0.90	0.89	0.88
-16.4	1.00	0.99	0.98	0.97	0.96	0.95	0.95	0.94	0.93	0.92	0.91	0.90	0.89	0.88	0.87
-32.8	—	0.98	0.98	0.97	0.96	0.95	0.94	0.93	0.93	0.92	0.91	0.90	0.89	0.87	0.85
-49.2	—	—	0.97	0.97	0.96	0.95	0.94	0.93	0.92	0.91	0.90	0.89	0.88	0.86	0.84
-65.6	—	—	—	0.96	0.95	0.95	0.94	0.93	0.92	0.91	0.90	0.89	0.88	0.86	0.83
-82.0	—	—	—	—	0.95	0.94	0.93	0.93	0.92	0.91	0.90	0.88	0.87	0.85	0.81
-98.4	—	—	—	—	—	0.94	0.93	0.92	0.91	0.90	0.89	0.88	0.86	0.84	0.80

Heating

Level Difference (ft)	Pipe length (ft)														
	16.4	32.8	49.2	65.6	82	98.4	114.8	131.2	147.6	164.0	180.4	196.9	213.3	229.7	246.1
98.4	—	—	—	—	—	0.96	0.95	0.94	0.93	0.92	0.91	0.91	0.90	0.89	0.88
82.0	—	—	—	—	0.97	0.96	0.95	0.94	0.93	0.92	0.91	0.91	0.90	0.89	0.88
65.6	—	—	—	0.97	0.97	0.96	0.95	0.94	0.93	0.92	0.91	0.91	0.90	0.89	0.88
49.2	—	—	0.98	0.97	0.97	0.96	0.95	0.94	0.93	0.92	0.91	0.91	0.90	0.89	0.88
32.8	—	0.99	0.98	0.97	0.97	0.96	0.95	0.94	0.93	0.92	0.91	0.91	0.90	0.89	0.88
16.4	1.00	0.99	0.98	0.97	0.97	0.96	0.95	0.94	0.93	0.92	0.91	0.91	0.90	0.89	0.88
0.0	1.00	0.99	0.98	0.97	0.97	0.96	0.95	0.94	0.93	0.92	0.91	0.91	0.90	0.89	0.88
-16.4	1.00	0.99	0.98	0.97	0.97	0.96	0.95	0.94	0.93	0.92	0.91	0.91	0.90	0.88	0.88
-32.8	—	0.99	0.98	0.97	0.97	0.96	0.95	0.94	0.93	0.92	0.91	0.91	0.90	0.89	0.88
-49.2	—	—	0.98	0.97	0.97	0.96	0.95	0.94	0.93	0.92	0.91	0.91	0.90	0.89	0.88
-65.6	—	—	—	0.97	0.97	0.96	0.95	0.94	0.93	0.92	0.91	0.91	0.90	0.89	0.88
-82.0	—	—	—	—	0.97	0.96	0.95	0.94	0.93	0.92	0.91	0.91	0.90	0.89	0.88
-98.4	—	—	—	—	—	0.96	0.95	0.94	0.93	0.92	0.91	0.91	0.90	0.89	0.88



Notes



Trane optimizes the performance of homes and buildings around the world. A business of Ingersoll Rand, the leader in creating and sustaining safe, comfortable and energy efficient environments, Trane offers a broad portfolio of advanced controls and HVAC systems, comprehensive building services, and parts. For more information, visit www.Trane.com.

Trane has a policy of continuous product and product data improvements and reserves the right to change design and specifications without notice.

©2015 Trane All rights reserved
MS-PRC020A-EN 22 Sep 2015
Supersedes (New)

We are committed to using environmentally
conscious print practices that reduce waste.

