



# Model Number Description

## Digit 1 — Unit Type

**T** = DX Cooling  
**Y** = DX Cooling, Gas Heat

## Digit 2 — Efficiency

**S** = Standard Efficiency  
**H** = High Efficiency

## Digit 3 — Airflow

**C** = Convertible

## Digit 4,5,6 — Nominal Gross Cooling Capacity (MBh)

**036** = 3 Ton  
**048** = 4 Ton  
**060** = 5 Ton  
**072** = 6 Ton  
**074** = 6 Ton, Dual Compressor  
**090** = 7.5 Ton, Single Compressor  
**092** = 7.5 Ton, Dual Compressor  
**102** = 8.5 Ton  
**120** = 10 Ton

## Digit 7 — Major Design Sequence

**E** = R-410A Refrigerant  
**F** = Microchannel Type Condenser Coils<sup>1</sup>  
**G** = Microchannel Type Evaporator and Condenser Coils  
**H** = Major Design Sequence

## Digit 8 — Voltage Selection

**1** = 208/230/60/1  
**3** = 208-230/60/3  
**4** = 460/60/3  
**W** = 575/60/3

## Digit 9 — Unit Controls

**E** = Electromechanical  
**R** = ReliaTel™ Microprocessor

## Digit 10 — Heating

*Note: Applicable to Digit 1, T models only.*

**0** = No Electric Heat  
**A** = 5 kW (1 phase)<sup>2</sup>  
**B** = 6 kW (3 phase)  
**C** = 9 kW (3 phase)  
**D** = 10 kW (1 phase)<sup>2</sup>  
**E** = 12 kW (3 phase)  
**F** = 14 kW (1 phase)<sup>2</sup>  
**G** = 18 kW (1&3 phase)  
**J** = 23 kW (3 phase)  
**K** = 27 kW (3 phase)  
**N** = 36 kW (3 phase)  
**P** = 54 kW (3 phase)

## Digit 10 — Heating (continued)

*Note: Applicable to Digit 1, Y models only.*

**L** = Low Heat  
**M** = Medium Heat  
**H** = High Heat  
**X** = Low Heat, Stainless Steel Heat Exchanger  
**Y** = Medium Heat, Stainless Steel Heat Exchanger  
**Z** = High Heat, Stainless Steel Heat Exchanger

## Digit 11 — Minor Design Sequence

**A** = First Sequence<sup>3</sup>  
**B** = Second Sequence<sup>4</sup>

## Digit 12, 13 — Service Sequence

**\*\*** = Factory Assigned

## Digit 14 — Fresh Air Selection

**0** = No Fresh Air  
**A** = Manual Outside Air Damper 0–50%<sup>5</sup>  
**B** = Motorized Outside Air Damper 0–50%<sup>6</sup>  
**C** = Economizer, Dry Bulb 0–100% without Barometric Relief<sup>7</sup>  
**D** = Economizer, Dry Bulb 0–100% with Barometric Relief<sup>7</sup>  
**E** = Economizer, Reference Enthalpy 0–100% without Barometric Relief<sup>7,8</sup>  
**F** = Economizer, Reference Enthalpy 0–100% with Barometric Relief<sup>7,8</sup>  
**G** = Economizer, Comparative Enthalpy 0–100% without Barometric Relief<sup>7,8</sup>  
**H** = Economizer, Comparative Enthalpy 0–100% with Barometric Relief<sup>7,8</sup>  
**K** = Low Leak Economizer with Barometric Relief  
**M** = Low Leak Economizer with Barometric Relief  
**P** = Low Leak Economizer with Comparative Enthalpy with Barometric Relief

## Digit 15 — Supply Fan/Drive Type/Motor

**0** = Standard Drive<sup>9</sup>  
**1** = Oversized Motor  
**2** = Optional Belt Drive Motor<sup>10</sup>  
**6** = Single Zone VAV<sup>11,12</sup>  
**7** = Multi-Speed Indoor Fan<sup>13</sup>  
**E** = VAV Supply Air Temperature Controls Standard Motor<sup>12</sup>

## Digit 16 — Hinged Service Access/ Filters

**0** = Standard Panels/Standard Filters  
**A** = Hinged Access Panels/Standard Filters  
**B** = Standard Panels/2" MERV 8 Filters  
**C** = Hinged Access Panels/2" MERV 8 Filters  
**D** = Standard Panels/2" MERV 13 Filters  
**E** = Hinged Access Panels/2" MERV 8 Filters

## Digit 17 — Condenser Coil Protection

**0** = Standard Coil  
**1** = Standard Coil with Hail Guard  
**2** = Black Epoxy Coil Pre-Coated Condenser Coil<sup>14</sup>  
**3** = Black Epoxy Coil Pre-Coated Condenser Coil with Hail Guard<sup>14</sup>  
**4** = CompleteCoat™ with Condenser Coil  
**5** = CompleteCoat™ with Hail Guard

## Digit 18 — Through-the-Base Provisions

*Note: Applicable to Digit 1, T or Y models only.*

**0** = No Through-the-Base Provisions  
**A** = Through-the-Base Electric<sup>15</sup>

*Note: Applicable to Digit 1, Y models only.*

**B** = Through-the-Base Gas Piping<sup>16</sup>  
**C** = Through-the-Base Electric and Gas Piping<sup>16</sup>

## Digit 19 — Disconnect/Circuit Breaker (three-phase only)

**0** = No Disconnect/No Circuit Breaker  
**1** = Unit Mounted/Non-Fused Disconnect<sup>15</sup>  
**2** = Unit Mounted Circuit Breaker<sup>15</sup>

## Digit 20— Convenience Outlet

**0** = No Convenience Outlet  
**A** = Unpowered Convenience Outlet  
**B** = Powered Convenience Outlet (three-phase only)<sup>17</sup>

## Digit 21— Communications Options<sup>8</sup>

**0** = No Communications Interface  
**1** = Trane® Communications Interface  
**2** = LonTalk® Communications Interface  
**3** = Novar 2024 Controls<sup>18</sup>  
**4** = Novar 3051 Controls without Zone Sensor<sup>18</sup>  
**5** = Novar 3051 Controls Interface with DCV<sup>18</sup>  
**6** = BACnet® Communications Interface  
**7** = Trane® Air-Fi® Communications Interface<sup>19</sup>

## Digit 22— Refrigeration System Option

**0** = Standard Refrigeration System<sup>20</sup>  
**B** = Dehumidification Option<sup>21,22</sup>

## Digit 23— Refrigeration Controls

*Note: Applicable to Digit 7 = E, F, G, H.*

**0** = No Refrigeration Control<sup>23</sup>  
**1** = Froststat™<sup>24,25</sup>



## General Data

**Table 6. General data – 6 to 7.5 tons – standard efficiency**

	<b>6 Tons</b>	<b>7.5 Tons</b>	<b>7.5 Tons</b>
	<b>T/YSC072H3,4,W</b>	<b>Single Compressor T/YSC090H3,4,W</b>	<b>Dual compressor T/YSC092H3,4,W</b>
<b>Cooling Performance<sup>(a)</sup></b>			
Gross Cooling Capacity	75,000	92,500	94,800
EER <sup>(b)</sup>	11.2	11.2	11.2
Nominal cfm/AHRI Rated cfm	2,400/2,100	3,000/2,400	3,000/2,325
AHRI Net Cooling Capacity	71,000	87,000	90,000
IEER (T/Y) <sup>(c)</sup>	12.9 / 12.7	12.9 / 12.7	12.9/12.7 <sup>(d)</sup>
System Power (kW)	6.36	7.77	8.04
<b>Compressor</b>			
Number/Type	1/Scroll	1/Scroll	2/Scroll
<b>Sound</b>			
Outdoor Sound Rating (dB) <sup>(e)</sup>	89	89	91
<b>Outdoor Coil</b>			
Type	Microchannel	Microchannel	Microchannel
Configuration	Full Face	Full Face	Face-split
Tube Size (in.)	0.71	1.00	0.71
Face Area (sq. ft.)	16.91	16.91	17.31
Rows/FPI (Fins per inch)	1/23	1/21	1/23
<b>Indoor Coil</b>			
Type	Lanced	Lanced	Lanced
Configuration	Full Face	Full Face	Face-split
Tube Size (in.)	0.3125	0.3125	0.3125
Face Area (sq. ft.)	9.89	9.89	12.36
Rows/FPI (Fins per inch)	3/16	4/16	3/16
Refrigerant Control	Thermal Expansion Valve	Thermal Expansion Valve	Thermal Expansion Valve
Drain Connection No./Size (in.)	1¾ NPT	1¾ NPT	1¾ NPT
<b>Outdoor Fan</b>			
Type	Propeller	Propeller	Propeller
No. Used/Diameter (in.)	1/26	1/26	1/26
Drive Type/No. Speeds	Direct/1	Direct/1	Direct/1
CFM	6,037	6400	6600
Motor HP	0.70	0.70	0.70
Motor RPM	1,100	1,100	1,100
<b>Indoor Fan</b>			
Type	FC Centrifugal	FC Centrifugal	FC Centrifugal <sup>(f)</sup>
No. Used/Diameter (in.)/Width (in.)	1/12x12	1/12x12	1/15x15 <sup>(g)</sup>
Drive Type/No. Speeds/RPM	Belt/Variable/1,750	Belt/Variable/1,750	Belt/Variable/1,750 <sup>(h)</sup>
Motor HP (Standard/Oversized)	1.0/2.0	1.0/3.0	1.0/3.0 <sup>(i)</sup>
Motor Frame Size (Standard/Oversized)	56/56	56/56	56/56
<b>Filters<sup>(j)</sup></b>			
Type Furnished	Throwaway	Throwaway	Throwaway
Number Size Recommended	(4) 16x25x2	(4) 16x25x2	(4) 20x25x2
<b>Refrigerant Charge<sup>(k)</sup></b>			
lbs of R-410A	5.5	7.5	3.8/3.6
<b>Heating Performance (Gas/ Electric Only)<sup>(l)</sup></b>			
<b>Heating Input</b>			
Low Heat Input (Btu)	80,000	120,000	120,000
Mid Heat Input (Btu)	120,000	150,000/105,000	150,000/105,000
High Heat Input (Btu)	150,000/105,000	200,000/140,000	200,000/140,000
<b>Heating Output</b>			

**Table 6. General data – 6 to 7.5 tons – standard efficiency (continued)**

	<b>6 Tons</b>	<b>7.5 Tons</b>	<b>7.5 Tons</b>
	<b>T/YSC072H3,4,W</b>	<b>Single Compressor T/YSC090H3,4,W</b>	<b>Dual compressor T/YSC092H3,4,W</b>
Low Heat Output (Btu)	64,000	96,000	96,000 <sup>(m)</sup>
Mid Heat Output (Btu)	96,000	120,000/84,000	120,000/84,000 <sup>(m)</sup>
High Heat Output (Btu)	120,000/84,000	160,000/112,000	160,000/112,000 <sup>(m)</sup>
<b>Steady State Efficiency %</b>			
Low Heat Input (Btu)	80	80	80 <sup>(n)</sup>
Mid Heat Input (Btu)	80	80	80 <sup>(n)</sup>
High Heat Input (Btu)	80	80	80 <sup>(n)</sup>
<b>No. Burners</b>			
Low Heat Output (Btu)	2	3	3
Mid Heat Output (Btu)	3	3	3
High Heat Output (Btu)	3	4	4 <sup>(o)</sup>
<b>No. Stages</b>			
Low Heat Input (Btu)	1	1	1
Mid Heat Input (Btu)	1	2	2
High Heat Input (Btu)	2	2	2
<b>Gas Supply Line Pressure</b>			
Natural (minimum/maximum)	4.5/14.0	4.5/14.0	4.5/14.0
LP (minimum/maximum)	11.0/14.0	11.0/14.0	11.0/14.0
<b>Gas Connection Pipe Size (in.)</b>			
Low Heat	1/2	1/2	1/2
Mid Heat	1/2	3/4	3/4
High Heat	3/4	3/4	3/4

- (a) Cooling performance is rated at 95°F ambient, 80°F entering dry bulb, 67°F entering wet bulb. Gross capacity does not include the effect of fan motor heat. AHRI capacity is net and includes the effect of fan motor heat. Units are suitable for operation to ±20% of nominal cfm. Units are certified in accordance with the Unitary Air-Conditioner Equipment certification program, which is based on AHRI Standard 340/360.
- (b) EER is rated at AHRI conditions and in accordance with DOE test procedures.
- (c) Integrated Efficiency Ratio (IEER) is rated in accordance with AHRI Standard 340/360. The IEER rating requires that the unit efficiency be determined at 100%, 75%, 50% and 25% load (net capacity) at the specified in AHRI Standard.
- (d) 13.7 IEER for SZVAV option, 13.4 IEER for Title24 2 speed fan option.
- (e) Outdoor sound rating shown is tested in accordance with AHRI Standard 270. For additional information reference the outdoor sound power level data in the performance section.
- (f) For SZVAV / Title 24 Option, Backward Airfoil Plenum
- (g) For SZVAV / Title 24 Option, 1/23.03
- (h) For SZVAV / Title 24 Option, Plenum/Variable/1,700
- (i) For SZVAV / Title 24 Option, 2.75
- (j) Optional 2" MERV 8 and MERV 13 filters also available.
- (k) Refrigerant charge is an approximate value. For a more precise value, see unit nameplate and service instructions.
- (l) Heating performance limit settings and rating data were established and approved under laboratory test conditions using American National Standards Institute standards. Ratings shown are for elevations up to 2000 feet. For elevations above 2000 feet, ratings should be reduced at the rate of 4% for each 1000 feet above sea level. Applicable to gas/electric units only.
- (m) For SZVAV / Title24 Option, Low = 97,200, Mid = 121,500, High = 162,000
- (n) For SZVAV / Title24 Option, Steady State Efficiency = 81%
- (o) 5 burners for SZVAV / Title24 Option



# Gross Cooling Capacities

**Table 16. Gross cooling capacities 7.5 tons standard efficiency – three phase T/YSC090H3,4,W**

CFM	Ent DB (°F)	Ambient Temperature (°F)						Ambient Temperature (°F)			Ambient Temperature (°F)								
		85						95			105								
		Entering Wet Bulb Temp (°F)						Entering Wet Bulb Temp (°F)			Entering Wet Bulb Temp (°F)								
		61		67		73		61	67	73	61	67	73						
		MBh	SHC	MBh	SHC	MBh	SHC	MBh	SHC	MBh	SHC	MBh	SHC						
2400	75	85.1	68.5	93.6	53.6	102.7	37.3	80.9	66.2	88.9	51.5	97.6	35.2	76.5	63.8	83.9	49.3	92.2	33.1
	80	85.8	80.8	94.0	65.8	102.8	50.1	81.7	78.6	89.5	63.6	97.7	48.1	77.4	76.2	84.7	61.2	92.3	46.0
	85	88.1	88.1	94.5	78.0	102.8	62.9	84.5	84.5	90.0	75.8	97.9	60.5	80.7	80.7	85.2	73.4	92.7	58.1
	90	92.6	92.6	95.1	90.4	103.3	74.8	88.9	88.9	90.8	88.2	98.4	72.6	85.0	85.0	86.1	85.8	93.1	70.2
2700	75	87.0	72.8	95.2	56.2	104.3	37.9	82.6	70.4	90.4	53.9	99.0	35.9	78.0	68.0	85.4	51.4	93.4	33.7
	80	87.9	86.8	95.9	69.7	104.3	52.4	83.7	83.7	91.2	67.4	99.1	50.3	79.4	79.4	86.2	64.9	93.4	48.2
	85	91.6	91.6	96.3	83.5	104.6	66.1	87.8	87.8	91.7	81.2	99.5	63.9	83.7	83.7	86.8	78.7	94.0	61.4
	90	96.2	96.2	97.3	97.3	105.0	79.8	92.3	92.3	92.9	92.9	99.9	77.5	88.1	88.1	88.2	88.2	94.4	75.1
3000	75	88.4	77.0	96.7	58.5	105.5	38.6	84.0	74.6	91.7	56.1	100.0	36.5	79.3	72.1	86.6	53.6	94.3	34.3
	80	89.9	89.9	97.4	73.6	105.6	54.6	85.7	85.7	92.5	71.2	100.1	52.5	81.6	81.6	87.3	68.6	94.4	49.9
	85	94.5	94.5	97.9	88.9	106.0	69.6	90.5	90.5	93.1	86.5	100.7	67.2	86.1	86.1	88.1	84.0	95.1	64.7
	90	99.3	99.3	99.4	99.4	106.3	84.8	95.1	95.1	95.2	95.2	101.0	82.4	90.6	90.6	90.7	90.7	95.4	79.9
3300	75	89.8	81.2	97.9	60.8	106.5	39.2	85.2	78.8	92.9	58.3	100.9	37.1	80.3	76.1	87.5	55.7	95.0	34.9
	80	92.0	92.0	98.6	77.4	106.6	56.6	87.9	87.9	93.6	74.9	101.1	54.2	83.5	83.5	88.3	72.3	95.4	51.7
	85	97.0	97.0	99.3	94.3	107.1	72.9	92.8	92.8	94.4	91.9	101.7	70.5	88.2	88.2	89.2	89.2	95.9	67.9
	90	101.8	101.8	101.9	101.9	107.4	89.7	97.4	97.4	97.5	97.5	101.9	87.3	92.6	92.6	92.7	92.7	96.2	84.7
3600	75	90.9	85.4	99.0	63.0	107.3	39.8	86.2	82.9	93.8	60.4	101.6	37.7	81.3	80.2	88.3	57.7	95.5	35.4
	80	94.1	94.1	99.6	81.1	107.6	58.5	89.8	89.8	94.5	78.6	102.0	56.0	85.2	85.2	89.0	75.9	96.1	53.4
	85	99.2	99.2	100.5	99.7	108.0	76.3	94.7	94.7	95.5	95.5	102.5	73.8	89.9	89.9	90.3	90.3	96.5	71.2
	90	104.0	104.0	104.1	104.1	108.3	94.6	99.3	99.3	99.4	99.4	102.7	92.2	94.3	94.3	94.4	94.4	96.8	89.6
CFM	Ent DB (°F)	Ambient Temperature (°F)						Ambient Temperature (°F)											
		115						125											
		Entering Wet Bulb Temp (°F)						Entering Wet Bulb Temp (°F)											
		61		67		73		61	67	73									
		MBh	SHC	MBh	SHC	MBh	SHC	MBh	SHC	MBh	SHC	MBh	SHC						
2400	75	71.9	61.3	78.8	46.7	86.4	30.9	67.1	58.7	73.4	44.0	80.1	28.5						
	80	73.0	73.0	79.6	58.7	86.5	43.7	68.3	68.3	74.2	56.0	80.2	41.2						
	85	76.7	76.7	80.2	70.9	87.0	55.6	72.2	72.2	74.7	68.2	80.9	52.8						
	90	80.8	80.8	81.2	81.2	87.4	67.7	76.1	76.1	76.2	76.2	81.2	64.9						
2700	75	73.3	65.4	80.1	48.8	87.3	31.5	68.2	62.6	74.4	46.0	80.8	29.0						
	80	75.0	75.0	80.9	62.3	87.5	45.6	70.5	70.5	75.2	59.5	81.2	42.8						
	85	79.3	79.3	81.5	76.2	88.2	58.8	74.5	74.5	75.9	73.4	81.8	56.0						
	90	83.5	83.5	83.6	83.6	88.5	72.5	78.3	78.3	78.4	78.4	82.0	69.6						
3000	75	74.4	69.4	81.1	50.9	88.0	32.0	69.2	66.6	75.3	48.0	81.3	29.6						
	80	77.1	77.1	81.9	66.0	88.4	47.3	72.3	72.3	76.0	63.1	81.9	44.4						
	85	81.5	81.5	82.7	81.4	89.0	62.0	76.4	76.4	76.9	76.9	82.4	59.0						
	90	85.6	85.6	85.7	85.7	89.3	77.2	80.1	80.1	80.2	80.2	82.7	74.3						
3300	75	75.3	73.4	81.9	52.9	88.6	32.5	70.0	70.0	75.9	49.9	81.7	30.1						
	80	78.9	78.9	82.6	69.5	89.2	48.9	73.8	73.8	76.6	66.5	82.5	45.9						
	85	83.3	83.3	83.7	83.7	89.7	65.2	77.9	77.9	77.9	77.9	82.9	62.1						
	90	87.4	87.4	87.5	87.5	90.0	82.0	81.6	81.6	81.6	81.6	83.1	78.9						
3600	75	76.2	76.2	82.6	54.9	89.0	33.0	70.8	70.8	76.4	51.8	81.9	30.5						
	80	80.4	80.4	83.3	73.1	89.8	50.5	75.0	75.0	77.1	70.0	82.9	47.4						
	85	84.8	84.8	84.8	84.8	90.2	68.3	79.1	79.1	79.1	79.1	83.2	65.2						
	90	88.8	88.8	88.9	88.9	90.5	86.7	82.7	82.7	82.8	82.8	83.5	83.5						

**Notes:**

1. All capacities shown are gross and have not considered indoor fan heat. To obtain NET cooling capacity subtract indoor fan heat. For indoor fan heat formula, refer to appropriate airflow table notes.
2. MBh = Total gross capacity
3. SHC = Sensible heat capacity



## Evaporator Fan Performance – Standard Efficiency

**Table 65. Belt drive evaporator fan performance – 7.5 tons standard efficiency with gas heat – YSC090H3,4,W low & medium gas heat downflow airflow**

External Static Pressure (Inches of Water Gauge)																					
		0.10"		0.20"		0.30"		0.40"		0.50"		0.60"		0.70"		0.80"		0.90"		1.00"	
CFM	RPM	BHP	RPM	BHP	RPM	BHP	RPM	BHP	RPM	BHP	RPM	BHP	RPM	BHP	RPM	BHP	RPM	BHP	RPM	BHP	
1-hp Standard Motor & Field Supplied Low Static Drive <sup>(a)</sup>											1-hp Standard Motor & Drive										
2400	655	0.47	707	0.55	758	0.64	802	0.72	845	0.80	886	0.88	925	0.97	961	1.05	997	1.14	1028	1.22	
2700	724	0.64	770	0.73	817	0.83	861	0.92	900	1.02	939	1.11	976	1.20	1011	1.30	1045	1.39	1077	1.49	
3000	794	0.86	837	0.96	878	1.06	920	1.17	958	1.27	994	1.38	1029	1.48	1063	1.58	1096	1.69	1128	1.79	
3300	865	1.12	905	1.23	942	1.34	980	1.45	1018	1.57	1053	1.69	1085	1.80	1117	1.92	1148	2.03	1179	2.14	
3600	937	1.43	973	1.55	1008	1.67	1042	1.79	1077	1.91	1112	2.05	1144	2.18	1174	2.30	1203	2.42	1232	2.55	
External Static Pressure (Inches of Water Gauge)																					
		1.10"		1.20"		1.30"		1.40"		1.50"		1.60"		1.70"		1.80"		1.90"		2.00"	
CFM	RPM	BHP	RPM	BHP	RPM	BHP	RPM	BHP	RPM	BHP	RPM	BHP	RPM	BHP	RPM	BHP	RPM	BHP	RPM	BHP	
1-hp Standard Motor & Drive											3-hp Oversized Motor & Drive										
2400	1060	1.30	1091	1.39	1120	1.48	1150	1.57	1178	1.65	1204	1.74	1231	1.83	1256	1.91	1281	2.00	1304	2.09	
2700	1109	1.58	1139	1.68	1167	1.77	1195	1.86	1223	1.96	1249	2.06	1275	2.16	1301	2.26	1325	2.35	1349	2.45	
3000	1158	1.90	1188	2.00	1216	2.11	1244	2.21	1271	2.32	1296	2.42	1321	2.53	1346	2.64	1371	2.75	1393	2.85	
3300	1209	2.26	1238	2.37	1265	2.49	1293	2.61	1319	2.72	1344	2.84	1369	2.95	1393	3.07	1416	3.18	1441	3.30	
3600	1261	2.67	1289	2.80	1316	2.92	1342	3.04	1368	3.17	1393	3.30	1419	3.43	—	—	—	—	—	—	
											3-hp Oversized Motor & Field Supplied High Static Drive <sup>(b)</sup>										

**Notes:**

- For standard evaporator fan speed (rpm), reference the standard motor and sheave/fan speed applicable table in the fan performance section.
- Data includes pressure drop due to standard filters and wet coils. No accessories or options are included in pressure drop data.
- To determine static pressure drop due to other options/accessories, refer to the applicable table in the fan performance section.
- 1-hp fan motor heat (MBh) = 2.829 x Fan bhp + .4024. 3-hp fan motor heat (MBh) = 2.900 x Fan bhp + .4750
- Factory supplied motors, in commercial equipment, are definite purpose motors, specifically designed and tested to operate reliably and continuously at all cataloged conditions. Using the full horsepower range of our fan motors as shown in our tabular data will not result in nuisance tripping or premature motor failure. Our product's warranty will not be affected.

<sup>(a)</sup> Field Supplied Fan Sheave AK74 and Belt AX35

<sup>(b)</sup> Field Supplied Fan Sheave BK52 and Belt BX30

## Evaporator Fan Performance — Standard Efficiency

**Table 66. Belt drive evaporator fan performance – 7.5 tons standard efficiency with gas heat – YSC090H3,4,W low & medium gas heat - horizontal airflow**

External Static Pressure (Inches of Water Gauge)																					
		0.10"		0.20"		0.30"		0.40"		0.50"		0.60"		0.70"		0.80"		0.90"		1.00"	
CFM	RPM	BHP	RPM	BHP	RPM	BHP	RPM	BHP	RPM	BHP	RPM	BHP	RPM	BHP	RPM	BHP	RPM	BHP	RPM	BHP	
1-hp Standard Motor & Field Supplied Low Static Drive <sup>(a)</sup>											1-hp Standard Motor & Drive										
2400	739	0.61	783	0.69	825	0.77	866	0.85	903	0.93	941	1.02	978	1.11	1013	1.20	1046	1.28	1078	1.37	
2700	821	0.85	861	0.94	898	1.03	935	1.12	972	1.21	1005	1.30	1038	1.39	1072	1.49	1104	1.59	1135	1.69	
3000	904	1.14	940	1.24	974	1.34	1008	1.44	1042	1.54	1075	1.65	1105	1.74	1135	1.85	1164	1.95	1195	2.06	
3300	987	1.49	1020	1.60	1052	1.71	1083	1.82	1113	1.93	1144	2.04	1174	2.16	1203	2.27	1230	2.38	1257	2.49	
3600	1071	1.92	1101	2.04	1131	2.15	1160	2.27	1188	2.39	1216	2.51	1244	2.64	1272	2.76	1298	2.88	1323	3.00	
External Static Pressure (Inches of Water Gauge)																					
		1.10"		1.20"		1.30"		1.40"		1.50"		1.60"		1.70"		1.80"		1.90"		2.00"	
CFM	RPM	BHP	RPM	BHP	RPM	BHP	RPM	BHP	RPM	BHP	RPM	BHP	RPM	BHP	RPM	BHP	RPM	BHP	RPM	BHP	
3-hp Oversized Motor & Drive											3-hp Oversized Motor & Field Supplied Drive <sup>(b)</sup>										
2400	1110	1.46	1140	1.55	1169	1.64	1198	1.73	1225	1.82	1251	1.91	1277	2.01	1301	2.10	1326	2.19	1350	2.28	
2700	1165	1.78	1195	1.88	1223	1.98	1251	2.08	1277	2.18	1304	2.29	1330	2.39	1355	2.49	1378	2.59	1402	2.70	
3000	1224	2.17	1252	2.28	1279	2.39	1306	2.49	1332	2.60	1358	2.71	1383	2.83	1407	2.94	1430	3.05	1454	3.16	
3300	1283	2.61	1311	2.73	1338	2.85	1364	2.97	1389	3.09	1413	3.21	1439	3.33	—	—	—	—	—	—	
3600	1349	3.13	1373	3.25	1398	3.38	—	—	—	—	—	—	—	—	—	—	—	—	—	—	

**Notes:**

1. For standard evaporator fan speed (rpm), reference the standard motor and sheave/fan speed applicable table in the fan performance section.
2. Data includes pressure drop due to standard filters and wet coils. No accessories or options are included in pressure drop data.
3. To determine static pressure drop due to other options/accessories, refer to the applicable table in the fan performance section.
4. 1-hp fan motor heat (MBh) = 2.829 x Fan bhp + .4024. 3-hp fan motor heat (MBh) = 2.900 x Fan bhp + .4750
5. Factory supplied motors, in commercial equipment, are definite purpose motors, specifically designed and tested to operate reliably and continuously at all cataloged conditions. Using the full horsepower range of our fan motors as shown in our tabular data will not result in nuisance tripping or premature motor failure. Our product's warranty will not be affected.

<sup>(a)</sup> Field Supplied Fan Sheave AK74 and Belt AX35

<sup>(b)</sup> Field Supplied Fan Sheave BK52 and Belt BX30



## Evaporator Fan Performance – Standard Efficiency

**Table 67. Belt drive evaporator fan performance – 7.5 tons standard efficiency with gas heat – YSC090H3,4,W high gas heat downflow airflow**

External Static Pressure (Inches of Water Gauge)																					
		0.10"		0.20"		0.30"		0.40"		0.50"		0.60"		0.70"		0.80"		0.90"		1.00"	
CFM	RPM	BHP	RPM	BHP	RPM	BHP	RPM	BHP	RPM	BHP	RPM	BHP	RPM	BHP	RPM	BHP	RPM	BHP	RPM	BHP	
1-hp Standard Motor & Field Supplied Low Static Drive <sup>(a)</sup>											1-hp Standard Motor & Drive										
2400	675	0.51	727	0.60	772	0.68	815	0.76	857	0.85	896	0.93	935	1.02	971	1.11	1006	1.19	1041	1.29	
2700	748	0.70	793	0.80	837	0.89	877	0.98	915	1.08	952	1.17	988	1.27	1022	1.37	1056	1.47	1089	1.57	
3000	821	0.94	862	1.04	903	1.15	941	1.25	976	1.35	1011	1.46	1045	1.57	1077	1.67	1109	1.78	1140	1.89	
3300	895	1.23	932	1.34	970	1.46	1007	1.58	1040	1.69	1072	1.79	1104	1.91	1134	2.03	1164	2.15	1194	2.27	
3600	969	1.57	1004	1.70	1038	1.82	1073	1.95	1106	2.07	1136	2.19	1166	2.32	1195	2.44	1223	2.57	1251	2.70	
External Static Pressure (Inches of Water Gauge)																					
		1.10"		1.20"		1.30"		1.40"		1.50"		1.60"		1.70"		1.80"		1.90"		2.00"	
CFM	RPM	BHP	RPM	BHP	RPM	BHP	RPM	BHP	RPM	BHP	RPM	BHP	RPM	BHP	RPM	BHP	RPM	BHP	RPM	BHP	
3-hp Oversized Motor & Drive																					
2400	1074	1.37	1105	1.46	1136	1.55	1165	1.64	1194	1.73	1222	1.83	1250	1.92	1275	2.00	1301	2.10	1326	2.18	
2700	1121	1.66	1151	1.76	1181	1.86	1211	1.97	1238	2.06	1266	2.17	1292	2.27	1318	2.37	1344	2.47	1369	2.57	
3000	1170	2.00	1199	2.11	1229	2.22	1256	2.33	1285	2.44	1311	2.55	1336	2.66	1363	2.77	1388	2.89	1413	3.00	
3300	1223	2.39	1251	2.50	1279	2.62	1305	2.74	1333	2.87	1358	2.98	1384	3.11	1408	3.23	1434	3.35	—	—	
3600	1279	2.83	1305	2.95	1331	3.08	1357	3.21	1383	3.34	—	—	—	—	—	—	—	—	—	—	
3-hp Oversized Motor & Field Supplied High Static Drive <sup>(b)</sup>																					

**Notes:**

1. For standard evaporator fan speed (rpm), reference the standard motor and sheave/fan speed applicable table in the fan performance section.
2. Data includes pressure drop due to standard filters and wet coils. No accessories or options are included in pressure drop data.
3. To determine static pressure drop due to other options/accessories, refer to the applicable table in the fan performance section.
4. 1-hp fan motor heat (MBh) = 2.829 x Fan bhp + .4024. 3-hp fan motor heat (MBh) = 2.900 x Fan bhp + .4750
5. Factory supplied motors, in commercial equipment, are definite purpose motors, specifically designed and tested to operate reliably and continuously at all cataloged conditions. Using the full horsepower range of our fan motors as shown in our tabular data will not result in nuisance tripping or premature motor failure. Our product's warranty will not be affected.

<sup>(a)</sup> Field Supplied Fan Sheave AK74 and Belt AX35

<sup>(b)</sup> Field Supplied Fan Sheave BK52 and Belt BX30

## Evaporator Fan Performance — Standard Efficiency

**Table 68. Belt drive evaporator fan performance – 7.5 tons standard efficiency with gas heat – YSC090H3,4,W high gas heat horizontal airflow**

External Static Pressure (Inches of Water Gauge)																					
		0.10"		0.20"		0.30"		0.40"		0.50"		0.60"		0.70"		0.80"		0.90"		1.00"	
CFM	RPM	BHP	RPM	BHP	RPM	BHP	RPM	BHP	RPM	BHP	RPM	BHP	RPM	BHP	RPM	BHP	RPM	BHP	RPM	BHP	
1-hp Standard Motor & Field Supplied Low Static Drive <sup>(a)</sup>											1-hp Standard Motor & Drive										
2400	776	0.70	819	0.79	859	0.87	898	0.96	936	1.05	972	1.13	1007	1.22	1039	1.31	1071	1.40	1102	1.49	
2700	863	0.97	901	1.07	938	1.16	974	1.26	1009	1.36	1043	1.46	1075	1.55	1106	1.65	1136	1.75	1165	1.85	
3000	951	1.31	985	1.42	1019	1.52	1052	1.63	1084	1.73	1116	1.84	1146	1.95	1176	2.06	1205	2.17	1232	2.28	
3300	1039	1.72	1071	1.84	1102	1.95	1132	2.07	1162	2.18	1191	2.30	1220	2.42	1248	2.54	1275	2.66	1302	2.78	
3600	1128	2.21	1157	2.34	1186	2.46	1214	2.59	1242	2.71	1269	2.84	1296	2.97	1322	3.10	1348	3.23	1373	3.36	
External Static Pressure (Inches of Water Gauge)																					
		1.10"		1.20"		1.30"		1.40"		1.50"		1.60"		1.70"		1.80"		1.90"		2.00"	
CFM	RPM	BHP	RPM	BHP	RPM	BHP	RPM	BHP	RPM	BHP	RPM	BHP	RPM	BHP	RPM	BHP	RPM	BHP	RPM	BHP	
3-hp Oversized Motor & Drive											3-hp Oversized Motor & Field Supplied High Static Drive <sup>(b)</sup>										
2400	1132	1.58	1161	1.68	1189	1.77	1216	1.86	1242	1.95	1268	2.04	1293	2.13	1318	2.23	1342	2.33	1364	2.42	
2700	1194	1.95	1222	2.05	1249	2.16	1276	2.26	1301	2.37	1327	2.48	1350	2.57	1374	2.68	1398	2.78	1421	2.88	
3000	1260	2.39	1286	2.50	1312	2.61	1337	2.72	1363	2.84	1387	2.96	1410	3.07	1434	3.19	1457	3.31	—	—	
3300	1328	2.90	1353	3.02	1378	3.14	1402	3.26	1426	3.39	—	—	—	—	—	—	—	—	—	—	
3600	—	—	—	—	—	—	—	—	—	—	—	—	—	—	—	—	—	—	—	—	

**Notes:**

1. For standard evaporator fan speed (rpm), reference the standard motor and sheave/fan speed applicable table in the fan performance section.
2. Data includes pressure drop due to standard filters and wet coils. No accessories or options are included in pressure drop data.
3. To determine static pressure drop due to other options/accessories, refer to the applicable table in the fan performance section.
4. 1-hp fan motor heat (MBh) = 2.829 x Fan bhp + .4024. 3-hp fan motor heat (MBh) = 2.900 x Fan bhp + .4750
5. Factory supplied motors, in commercial equipment, are definite purpose motors, specifically designed and tested to operate reliably and continuously at all cataloged conditions. Using the full horsepower range of our fan motors as shown in our tabular data will not result in nuisance tripping or premature motor failure. Our product's warranty will not be affected.

<sup>(a)</sup> Field Supplied Fan Sheave AK74 and Belt AX35

<sup>(b)</sup> Field Supplied Fan Sheave BK52 and Belt BX30



## Evaporator Fan Performance – Standard Efficiency

**Table 69. Belt drive evaporator fan performance – 7.5 tons standard efficiency – TSC092H3,4,W downflow airflow**

External Static Pressure (Inches of Water Gauge)																					
		0.10"		0.20"		0.30"		0.40"		0.50"		0.60"		0.70"		0.80"		0.90"		1.00"	
CFM	RPM	BHP	RPM	BHP	RPM	BHP	RPM	BHP	RPM	BHP	RPM	BHP	RPM	BHP	RPM	BHP	RPM	BHP	RPM	BHP	
1-hp Standard Motor & Field Supplied Low Static Drive <sup>(a)</sup>											1-hp Standard Motor & Drive										
2400	—	—	474	0.36	524	0.44	570	0.52	611	0.59	650	0.68	686	0.76	720	0.84	752	0.93	783	1.02	
2700	458	0.39	508	0.47	554	0.55	598	0.64	638	0.73	676	0.82	711	0.91	745	1.00	776	1.09	806	1.19	
3000	498	0.52	544	0.60	587	0.69	628	0.78	666	0.88	704	0.98	738	1.08	770	1.18	801	1.28	831	1.38	
3300	539	0.67	581	0.76	621	0.85	660	0.96	696	1.06	732	1.17	766	1.28	797	1.39	828	1.49	856	1.60	
3600	580	0.85	620	0.95	657	1.05	693	1.16	728	1.27	761	1.38	794	1.50	825	1.62	855	1.74	882	1.85	
External Static Pressure (Inches of Water Gauge)																					
		1.10"		1.20"		1.30"		1.40"		1.50"		1.60"		1.70"		1.80"		1.90"		2.00"	
CFM	RPM	BHP	RPM	BHP	RPM	BHP	RPM	BHP	RPM	BHP	RPM	BHP	RPM	BHP	RPM	BHP	RPM	BHP	RPM	BHP	
1-hp Standard Motor & Drive											3-hp Oversized Motor & Drive <sup>(b)</sup>										
2400	813	1.10	841	1.19	868	1.28	894	1.37	920	1.46	943	1.54	967	1.63	990	1.72	1012	1.81	1035	1.90	
2700	836	1.29	864	1.39	891	1.48	917	1.58	942	1.68	966	1.78	990	1.88	1012	1.97	1035	2.07	1056	2.17	
3000	860	1.49	887	1.60	914	1.70	940	1.81	964	1.92	988	2.03	1012	2.13	1035	2.24	1056	2.35	1079	2.46	
3300	885	1.72	911	1.83	938	1.94	963	2.06	988	2.18	1012	2.30	1035	2.42	1057	2.54	1079	2.65	1100	2.77	
3600	910	1.97	937	2.09	963	2.22	988	2.34	1012	2.46	1035	2.59	1059	2.72	1081	2.85	1104	2.98	1124	3.11	
3-hp Oversized Motor & Field Supplied High Static Drive <sup>(c)</sup>																					

**Notes:**

1. For standard evaporator fan speed (rpm), reference the standard motor and sheave/fan speed applicable table in the fan performance section.
2. Data includes pressure drop due to standard filters and wet coils. No accessories or options are included in pressure drop data.
3. To determine static pressure drop due to other options/accessories, refer to the applicable table in the fan performance section.
4. 1-hp fan motor heat (MBh) = 2.829 x fan bhp + .4024. 3-hp fan motor heat (MBh) = 2.900 x Fan bhp - .3800
5. Factory supplied motors, in commercial equipment, are definite purpose motors, specifically designed and tested to operate reliably and continuously at all cataloged conditions. Using the full horsepower range of our fan motors as shown in our tabular data will not result in nuisance tripping or premature motor failure. Our product's warranty will not be affected.

<sup>(a)</sup> BAYLSDR009A

<sup>(b)</sup> BAYHSMT400A

<sup>(c)</sup> Field Supplied AK56 x 1" Fan Sheave

**Table 156. Static pressure drop through accessories (inches water column) – standard efficiency – 3 to 10 tons**

Tons	Unit Model Number	cfm	Standard Filters <sup>(a)</sup>	2" MERV 8 Filter	2" MERV 13 Filter	Economizer with OA/RA Dampers <sup>(b)</sup>						Electric Heater Accessory (kW) <sup>(c)</sup>			
						Downflow		Low Leak <sup>(d)</sup>		Horizontal		5-6	9-18	23-36	54
						100% OA	100% RA	100% OA	100% RA	100% OA	100% RA	5-6	9-18	23-36	54
3	T/YSC036G	960	0.01	0.03	0.04	0.04	0.01	0.11	0.04	0.04	0.01	0.01	0.01	0.01	—
3	T/YSC036G	1200	0.02	0.04	0.05	0.06	0.01	0.17	0.07	0.06	0.01	0.02	0.02	0.02	—
3	T/YSC036G	1440	0.03	0.05	0.06	0.08	0.02	0.23	0.09	0.08	0.01	0.02	0.03	0.03	—
4	T/YSC048G	1280	0.03	0.05	0.06	0.09	0.02	0.08	0.04	0.09	0.01	0.02	0.03	0.03	—
4	T/YSC048G	1600	0.04	0.07	0.07	0.13	0.04	0.13	0.08	0.13	0.02	0.04	0.05	0.05	—
4	T/YSC048G	1920	0.06	0.10	0.08	0.17	0.06	0.20	0.09	0.17	0.02	0.05	0.06	0.08	—
5	T/YSC060G	1600	0.04	0.07	0.07	0.13	0.04	0.14	0.08	0.13	0.02	0.04	0.05	0.05	—
5	T/YSC060G	2000	0.06	0.10	0.09	0.18	0.07	0.22	0.10	0.18	0.02	0.06	0.07	0.08	—
5	T/YSC060G	2400	0.08	0.13	0.10	0.25	0.11	0.31	0.11	0.25	0.03	0.08	0.10	0.12	—
6	T/YSC072H	1920	0.04	0.07	0.10	0.10	0.01	0.20	0.09	0.06	0.02	—	0.01	0.02	—
6	T/YSC072H	2400	0.06	0.09	0.13	0.11	0.02	0.31	0.11	0.08	0.02	—	0.02	0.03	—
6	T/YSC072H	2880	0.09	0.12	0.15	0.13	0.04	0.46	0.19	0.10	0.04	—	0.03	0.05	—
7.5	T/YSC090H	2400	0.04	0.06	0.12	0.11	0.02	0.20	0.09	0.08	0.02	—	0.02	0.02	—
7.5	T/YSC090H	3000	0.06	0.09	0.13	0.14	0.05	0.31	0.11	0.12	0.05	—	0.03	0.03	—
7.5	T/YSC090H	3600	0.09	0.13	0.15	0.21	0.07	0.46	0.19	0.25	0.08	—	0.04	0.05	—
7.5	T/YSC092H	2400	0.04	0.06	0.12	0.11	0.02	0.20	0.11	0.08	0.02	—	0.02	0.02	—
7.5	T/YSC092H	3000	0.06	0.09	0.13	0.14	0.05	0.31	0.20	0.12	0.05	—	0.03	0.03	—
7.5	T/YSC092H	3600	0.09	0.13	0.15	0.21	0.07	0.46	0.30	0.25	0.08	—	0.04	0.05	—
8.5	T/YSC102H	2720	0.05	0.08	0.13	0.12	0.03	0.42	0.18	0.09	0.04	—	0.02	0.03	—
8.5	T/YSC102H	3400	0.08	0.11	0.14	0.19	0.06	0.63	0.21	0.18	0.06	—	0.03	0.04	—
8.5	T/YSC102H	4080	0.12	0.16	0.16	0.30	0.07	0.91	0.34	0.31	0.09	—	0.05	0.06	—
10	T/YSC120H	3200	0.07	0.10	0.14	0.17	0.05	0.42	0.18	0.14	0.05	—	0.02	0.03	0.05
10	T/YSC120H	4000	0.11	0.15	0.16	0.26	0.07	0.63	0.21	0.30	0.08	—	0.02	0.03	0.05
10	T/YSC120H	4800	0.16	0.20	0.18	0.34	0.09	0.91	0.34	0.35	0.10	—	0.03	0.04	0.06

**Note:** Tests follow AR1270-95.

(a) Tested with standard filters. Difference in pressure drop should be considered when utilizing optional 2" MERV 8 and MERV 13 filters.

(b) OA = Outside Air and RA = Return Air.

(c) Nominal kW ratings at 240, 480, 600 volts. Heaters only available on T units. Electric heaters restricted on applications below 320 cfm/ton.

(d) Low leak - downflow only.



# Electrical Data

Table 165. Unit wiring – standard efficiency

Tons	Unit Model Number	Voltage Range	Standard Indoor Fan Motor <sup>(a)</sup>		Oversized Indoor Fan Motor <sup>(b)</sup>		Optional EBM Fan Motor	
			MCA	Max Fuse Size or Max Circuit Breaker	MCA	Max Fuse Size or Max Circuit Breaker	MCA	Max Fuse Size or Max Circuit Breaker
3	T/YSC036G3	187-253	20	30	23	30	—	—
3	T/YSC036G4	414-506	10	15	12	15	—	—
3	T/YSC036GW	517-633	8	15	9	15	—	—
4	T/YSC048G3	187-253	26	35	27	40	—	—
4	T/YSC048G4	414-506	11	15	13	15	—	—
4	T/YSC048GW	517-633	10	15	11	15	—	—
5	T/YSC060G3	187-253	29	40	30	45	—	—
5	T/YSC060G4	414-506	13	15	14	20	—	—
5	T/YSC060GW	517-633	10	15	11	15	—	—
6	T/YSC072H3	187-253	35	50	38	50	—	—
6	T/YSC072H4	414-506	17	25	18	25	—	—
6	T/YSC072HW	517-633	13	20	14	20	—	—
7.5	T/YSC090H3	187-253	38	60	44	60	—	—
7.5	T/YSC090H4	414-506	19	30	22	30	—	—
7.5	T/YSC090HW	517-633	15	20	17	25	—	—
7.5	T/YSC092H3	187-253	39	50	45	50	43	50
7.5	T/YSC092H4	414-506	18	20	21	25	20	25
7.5	T/YSC092HW	517-633	15	20	17	20	22	25
8.5	T/YSC102H3	187-253	44	50	47	60	45	60
8.5	T/YSC102H4	414-506	21	25	23	25	22	25
8.5	T/YSC102HW	517-633	16	20	17	20	22	25
10	T/YSC120H3	187-253	49	60	—	—	—	—
10	T/YSC120H4	414-506	22	25	—	—	—	—
10	T/YSC120HW	517-633	22	25	—	—	—	—

**Note:** T/YSC092F (7.5 ton) models have a dual refrigeration system.

- <sup>(a)</sup> The standard motor for 3-phase (3 to 5 ton models) is a multispeed, direct drive motor. The standard motor for 3-phase (6 to 8.5 ton models) is a belt drive motor.
- <sup>(b)</sup> The oversized motor for 3-phase (3 to 5 ton models) is a multispeed, direct drive motor. The oversized motor for 3-phase (6 to 8.5 ton models) is a belt drive motor.



**Electrical Data**

**Table 167. Electrical characteristics – compressor motor and condenser motor – 60 cycle – standard efficiency**

Tons	Unit Model Number	No.	Compressor Motors						No.	Condenser Fan Motor				
			Volts	Phase	hp <sup>(a)</sup>	rpm	Amps <sup>(b)</sup>			Volts	Phase	hp	Amps	
							RLA	LRA					FLA	LRA
3	T/YSC036G3	1	208-230	3	2.8	3500	10.4	73	1	208-230	3	0.25	1.1	3.6
3	T/YSC036G4	1	460	3	2.8	3500	5.8	38	1	460	3	0.25	0.55	1.8
3	T/YSC036GW	1	575	3	2.8	3500	3.8	36.5	1	575	3	0.25	0.45	1.4
4	T/YSC048G3	1	208-230	3	3.6	3500	13.7	83.1	1	208-230	3	0.33	1.4	4.6
4	T/YSC048G4	1	460	3	3.6	3500	6.2	41	1	460	3	0.33	0.7	2.3
4	T/YSC048GW	1	575	3	3.5	3500	4.8	33	1	575	3	0.33	0.55	1.8
5	T/YSC060G3	1	208-230	3	4.3	3500	15.9	110	1	208-230	3	0.4	1.4	5.2
5	T/YSC060G4	1	460	3	4.3	3500	7.1	52	1	460	3	0.4	0.7	2.6
5	T/YSC060GW	1	575	3	4.3	3500	5.1	40	1	575	3	0.4	0.6	2.1
6	T/YSC072H3	1	208-230	3	5.6	3500	22.4	149	1	208-230	3	0.7	3.3	12.3
6	T/YSC072H4	1	460	3	5.6	3500	10.6	75	1	460	3	0.7	1.5	6.1
6	T/YSC072HW	1	575	3	5.6	3500	7.7	54	1	575	3	0.7	1.4	5.1
7.5	T/YSC090H3	1	208-230	3	6.7	3500	25	164	1	208-230	3	0.7	3.3	12.3
7.5	T/YSC090H4	1	460	3	6.7	3500	12.2	100	1	460	3	0.7	1.5	6.1
7.5	T/YSC090HW	1	575	3	6.7	3500	9	78	1	575	3	0.7	1.4	5.1
7.5	T/YSC092H3	1	208-230	3	3.7/3.1	3500/3500	14.5/14	98.0/83.1	1	208-230	3	0.7	3.3	12.3
7.5	T/YSC092H4	1	460	3	3.7/3.1	3500/3500	6.3/6.27	55.0/41.0	1	460	3	0.7	1.5	6.1
7.5	T/YSC092HW	1	575	3	3.7/3.1	3500/3500	6/4.29	41.0/33.0	1	575	3	0.7	1.4	5.1
8.5	T/YSC102H3	2	208-230	3	3.7/3.7	3500/3500	16/13.72	110/83.1	1	208-230	3	0.7	3.3	12.3
8.5	T/YSC102H4	2	460	3	3.7/3.7	3500/3500	7.8/6.22	52/41.0	1	460	3	0.7	1.5	6.1
8.5	T/YSC102HW	2	575	3	3.7/3.7	3500/3500	5.7/4.81	38.9/33	1	575	3	0.7	1.4	5.1
10	T/YSC120H3	2	208-230	3	4.8/3.7	3500/3500	19.6/13.1	136.0/83.1	1	208-230	3	0.7	3.3	12.3
10	T/YSC120H4	2	460	3	4.8/3.7	3500/3500	8.2/6.1	66.1/41.0	1	460	3	0.7	1.5	6.1
10	T/YSC120HW	2	575	3	4.8/3.7	3500/3500	6.6/4.4	55.3/33.0	1	575	3	0.7	1.4	5.1

<sup>(a)</sup> hp for each compressor

<sup>(b)</sup> Amp draw for each motor (compressor and standard indoor fan motor); multiply value by number of motors to determine total amps.

**Table 168. Electrical characteristics – standard evaporator fan motor – 60 cycle – direct or belt drive standard efficiency**

Tons	Unit Model Number	Direct or Belt Drive	No.	Volts	Phase	hp	Amps	
							FLA	LRA
3	T/YSC036G3	Direct Drive	1	208-230	1	0.75	5.7	—
3	T/YSC036G4	Direct Drive	1	460	1	0.75	1.7	—
3	T/YSC036GW	Direct Drive	1	575	1	0.75	2.4	—
4	T/YSC048G3	Direct Drive	1	208-230	1	1	6.9	—
4	T/YSC048G4	Direct Drive	1	460	1	1	2.5	—
4	T/YSC048GW	Direct Drive	1	575	1	1	2.9	—
5	T/YSC060G3	Direct Drive	1	208-230	1	1	6.9	—
5	T/YSC060G4	Direct Drive	1	460	1	1	2.5	—
5	T/YSC060GW	Direct Drive	1	575	1	1	2.9	—
6	T/YSC072H3	Belt Drive	1	208-230	3	1	3.4	32.2

**Table 168. Electrical characteristics — standard evaporator fan motor – 60 cycle — direct or belt drive standard efficiency (continued)**

Tons	Unit Model Number	Direct or Belt Drive	No.	Volts	Phase	hp	Amps	
							FLA	LRA
6	T/YSC072H4	Belt Drive	1	460	3	1	1.6	16.1
6	T/YSC072HW	Belt Drive	1	575	3	1	1.7	13.2
7.5	T/YSC090H3	Belt Drive	1	208-230	3	1	3.3	12.5
7.5	T/YSC090H4	Belt Drive	1	460	3	1	1.6	12.5
7.5	T/YSC090HW	Belt Drive	1	575	3	1	1.4	10
7.5	T/YSC092H3	Belt Drive	1	208-230	3	1	3.3	12.5
7.5	T/YSC092H4	Belt Drive	1	460	3	1	1.6	12.5
7.5	T/YSC092HW	Belt Drive	1	575	3	1	1.4	10
7.5	T/YSC092H3	Direct Drive	1	208-230	3	2.75	7.3	—
7.5	T/YSC092H4	Direct Drive	1	460	3	2.75	3.6	—
7.5	T/YSC092HW	Direct Drive	1	575	3	2.75	7.5	—
8.5	T/YSC102H3	Belt Drive	1	208-230	3	2	6.3	48
8.5	T/YSC102H4	Belt Drive	1	460	3	2	3.1	24
8.5	T/YSC102HW	Belt Drive	1	575	3	2	2.5	18.2
8.5	T/YSC102H3	Direct Drive	1	208-230	3	2.75	7.3	—
8.5	T/YSC102H4	Direct Drive	1	460	3	2.75	3.6	—
8.5	T/YSC102HW	Direct Drive	1	575	3	2.75	7.5	—
10	T/YSC120H3	Direct Drive	1	208-230	3	2.75	7.3	—
10	T/YSC120H4	Direct Drive	1	460	3	2.75	3.6	—
10	T/YSC120HW	Direct Drive	1	575	3	2.75	7.5	—

**Notes:**

1. Precedent™ 3 to 5 ton models rated at 575V utilize a 208-230V evaporator Fan motor powered through a 575/230V transformer assembly. Motor voltage/FLA rated at transformer input.
2. Precedent™ 10 ton models rated at 575V utilize a 380-480V evaporator Fan motor powered through a 575/480V transformer assembly. Motor voltage/FLA rated at transformer input.

**Table 169. Electrical characteristics — oversized evaporator fan motor – 60 cycle — belt drive — standard efficiency**

Tons	Unit Model Number	Direct or Belt Drive	No.	Volts	Phase	hp	Amps	
							FLA	LRA
3	T/YSC036G3	Direct Drive	1	208-230	1	1.5	8.2	-
3	T/YSC036G4	Direct Drive	1	460	1	1.5	4.8	-
3	T/YSC036GW	Direct Drive	1	575	1	1.5	3.5	-
4	T/YSC048G3	Direct Drive	1	208-230	1	1.5	8.2	-
4	T/YSC048G4	Direct Drive	1	460	1	1.5	4.8	-
4	T/YSC048GW	Direct Drive	1	575	1	1.5	3.5	-
5	T/YSC060G3	Direct Drive	1	208-230	1	1.5	8.2	-
5	T/YSC060G4	Direct Drive	1	460	1	1.5	4.8	-
5	T/YSC060GW	Direct Drive	1	575	1	1.5	3.5	-
6	T/YSC072H3	Belt Drive	1	208-230	3	2	6.3	48.0
6	T/YSC072H4	Belt Drive	1	460	3	2	3.1	24.0
6	T/YSC072HW	Belt Drive	1	575	3	2	2.5	18.2
7.5	T/YSC090H3	Belt Drive	1	208-230	3	3	9.4	52.4
7.5	T/YSC090H4	Belt Drive	1	460	3	3	4.6	26.3
7.5	T/YSC090HW	Belt Drive	1	575	3	3	3.4	29.4
7.5	T/YSC092H3	Belt Drive	1	208-230	3	3	9.4	83.0
7.5	T/YSC092H4	Belt Drive	1	460	3	3	4.6	42.0
7.5	T/YSC092HW	Belt Drive	1	575	3	3	3.4	31.0

# Weights

**Table 181. Maximum unit & corner weights (lbs) and center of gravity dimensions (in.) – cooling models**

Tons	Unit Model No.	Maximum Model Weights <sup>(a)</sup>		Corner Weights <sup>(b)</sup>				Center of Gravity (in.)	
		Shipping	Net	A	B	C	D	Length	Width
3	TSC036G	537	431	201	155	25	50	29	8
4	TSC048G	557	452	213	159	27	53	29	8
5	TSC060G	603	498	218	140	50	90	27	12
6	TSC072H	762	667	218	186	131	132	44	21
7.5	TSC090H	772	679	186	217	106	170	34	22
7.5	TSC092H	940	797	249	235	163	149	46	21
8.5	TSC102H	938	837	273	222	183	159	47	22
10	TSC120H	1058	960	320	218	233	189	40	24
3	THC036E	555	481	157	122	95	107	31	19
4	THC048E	787	692	220	178	132	163	40	23
4	THC048F	737	642	208	177	128	130	44	22
5	THC060E	841	746	241	193	139	173	39	22
5	THC060F	774	679	219	189	135	137	43	21
6	THC072E	943	845	274	172	186	213	41	24
6	THC072F	883	740	228	219	155	138	47	21
6	THC074F	1016	918	309	207	223	178	40	24
7.5	THC092F	1026	928	315	209	224	180	40	24
8.5	THC102F	1035	937	316	212	227	181	49	24
10	THC120F	1326	1132	326	326	258	222	53	27

<sup>(a)</sup> Weights are approximate.

<sup>(b)</sup> Corner weights are given for information only.

**Figure 32. Corner weights**

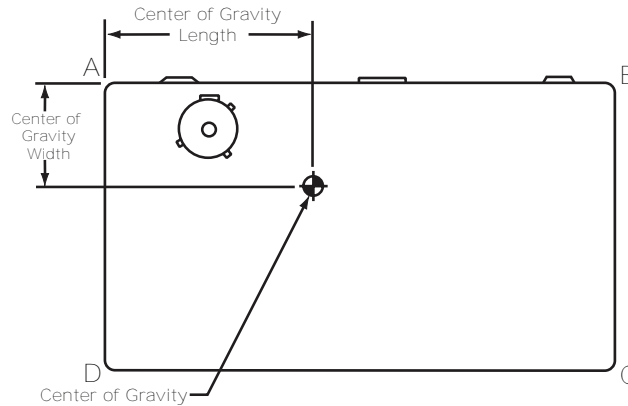

**Table 182. Maximum unit & corner weights (lbs) and center of gravity dimensions (in.) – gas/electric models**

Tons	Unit Model No.	Maximum Model Weights <sup>(a)</sup>		Corner Weights <sup>(b)</sup>				Center of Gravity (in.)	
		Shipping	Net	A	B	C	D	Length	Width
3	YSC036G	577	472	193	178	45	55	33	9
4	YSC048G	598	492	205	183	46	58	33	9
5	YSC060G	627	522	214	193	52	63	33	10
6	YSC072H	805	710	222	217	121	150	41	22
7.5	YSC090H	853	760	206	237	127	190	36	22
7.5	YSC092H	990	847	265	249	173	160	46	21
8.5	YSC102H	986	885	285	234	195	171	47	22
10	YSC120H	1156	1058	345	242	258	213	41	23

**Table 182. Maximum unit & corner weights (lbs) and center of gravity dimensions (in.) – gas/electric models (continued)**

Tons	Unit Model No.	Maximum Model Weights <sup>(a)</sup>		Corner Weights <sup>(b)</sup>				Center of Gravity (in.)	
		Shipping	Net	A	B	C	D	Length	Width
3	YHC036E	607	532	165	137	95	134	31	19
4	YHC048E	858	763	238	200	148	176	40	23
4	YHC048F	806	711	226	199	144	143	44	22
5	YHC060E	917	822	261	218	156	187	40	22
5	YHC060F	850	755	239	214	152	151	44	21
6	YHC072E	1025	927	296	198	205	228	41	24
6	YHC072F	965	822	250	245	174	153	47	21
6	YHC074F	1114	1016	334	231	248	202	41	23
7.5	YHC092F	1124	1026	340	233	249	204	41	23
8.5	YHC102F	1133	1035	341	236	253	205	49	23
10	YHC120F	1453	1259	356	371	289	242	54	27

(a) Weights are approximate.

(b) Corner weights are given for information only.

**Table 183. Factory installed options (fiops)/accessory net weights (lbs)**

Accessory	T/YSC036G-060G	T/YHC048E-060E	T/YSC072H-102H	T/YSC120H	T/YHC120F
	T/YHC036E	T/YHC048F-060F	T/YHC072E/F	T/YHC074F-102F	Net Weight
	Net Weight	Net Weight	Net Weight	Net Weight	Net Weight
	3 to 5 Tons	4 to 5 Tons	6 to 8.5 Tons	6,7.5,8.5,10 Tons	10 Tons
Barometric Relief	7	10	10	10	10
Belt Drive Option (3 phase only)	31	31	—	—	—
Coil Guards	12	20	20	20	30
Economizer	26	36	36	36	36
Electric Heaters <sup>(a)</sup>	15	30	30	44	50
Hinged Doors	10	12	12	12	12
Low Leak Economizer	68	93	93	93	93
Manual Outside Air Damper	16	26	26	26	26
Motorized Outside Air Damper	20	30	30	30	30
Novar Control	8	8	8	8	8
Oversized Motor	5	8	8	—	—
Powered Convenience Outlet	38	38	38	38	50
Powered Exhaust	40	40	80	80	80
Reheat Coil	12 <sup>(b)</sup>	14	15	20 <sup>(c)</sup>	30
Roof Curb	61	78	78	78	89
Smoke Detector, Supply	5	5	5	5	5
Smoke Detector, Return	7	7	7	7	7
Stainless Steel Heat Exchanger <sup>(d)</sup>	4	6	6	6	6
Through-the-Base Electrical	8	13	13	13	13
Through-the-Base Gas	5	5	5	5	5
Unit Mounted Circuit Breaker	5	5	5	5	5
Unit Mounted Disconnect	5	5	5	5	5

**Notes:**

- Weights for options not listed are <5 lbs.
- Net weight should be added to unit weight when ordering factory-installed accessories.

(a) Applicable to cooling units only.

(b) Reheat weight here is only applicable to T/YHC036E models.

(c) Reheat weight for this value only applicable to 7.5 and 8.5 Ton high efficiency "F" models.

(d) Applicable to gas/electric units only.



# Mechanical Specifications

## Standard

### General

- Packaged rooftop units cooling, heating capacities, and efficiencies are AHRI Certified within scope of AHRI Standard 210-240 for 3 to 5 ton units or 340-360 (I-P) for 6 to 10 ton units and ANSIZ21.47 and 10 CFR Part 431 pertaining to Commercial Warm Air Furnaces (all gas heating units)
- Convertible airflow
- Microprocessor controls operating range between 115°F and 0°F in cooling mode standard from the factory
- Electromechanical controls operating range between 115°F and 40°F
- Factory assembled, internally wired, fully charged with R-410A, and 100 percent run tested to check cooling operation, fan and blower rotation, and control sequence before leaving the factory
- Colored and numbered wiring internal to the unit for simplified identification
- Units cULus listed and labeled, classified in accordance for Central Cooling Air Conditioners

### Casing

- Zinc coated, heavy gauge, galvanized steel
- Weather-resistant baked enamel finish on phosphatized exterior surfaces
- Meets ASTM B117, 672 hour salt spray test
- Removable single side maintenance access panels
- Lifting handles in maintenance access panels (can be removed and reinstalled by removing two fasteners while providing a water and air tight seal)
- Exposed vertical panels and top covers in the indoor air section insulated with a cleanable foil-faced, fire-retardant permanent, odorless glass fiber material
- Base pan shall have no penetrations within the perimeter of the curb other than the raised 1 1/8 inch high downflow supply/return openings to provide an added water integrity precaution, if the condensate drain backs up.
- Base of the unit insulated with 1/8 inch, foil-faced, captured and sealed, closed-cell insulation
- Unit base provisions for forklift and/or crane lifting on three sides of unit

### Coils

#### Evaporator and Condenser

- Internally finned, 5/16" copper tubes mechanically bonded to a configured aluminum plate fin
- Evaporator coils standard for all 3 to 10 ton standard efficiency models
- Coils leak tested to 600 psig
- Assembled unit leak tested to 465 psig
- Condenser coil — patent pending 1+1+1 hybrid coil designed with slight gaps for ease of cleaning
- Standard plastic, dual-sloped, removable and reversible condensate drain pan with through-the-base condensate drain

#### Microchannel Condenser

- Standard for 3 to 10 ton standard efficiency models and 4,5,6, 7.5, 8.5 ton high efficiency models
- Not offered on the 4 and 5 ton dehumidification models
- Optimal heat transfer performance due to flat, streamlined tubes with small ports, and metallurgical tube-to-fin bond
- Reduce system refrigerant charge by up to 50% leading to better compressor reliability
- Compact all-aluminum microchannel coils reduce the unit weight
- Recyclable all aluminum coils All aluminium construction minimizes galvanic corrosion
- Strong aluminum brazed structure provides better fin protection

- Flat streamlined tubes more dust resistant and easy to clean
- Coils leak tested at the factory to ensure the pressure integrity

## Compressors

- All units have direct-drive, hermetic, scroll type compressors with centrifugal type oil pumps
- Suction gas-cooled motor with voltage utilization range of plus or minus 10 percent of unit nameplate voltage
- Internal overloads standard with scroll compressors
- Crankcase heaters optional on 3 to 10 ton standard efficiency units and standard on 3 to 10 ton high efficiency units
- Dual compressors recommended for humidity control, light load cooling conditions and system back-up applications
- Three stages of cooling available on 6 to 10 ton high efficiency units with dual compressors

## Controls

- Units factory-wired with necessary controls and contactor pressure lugs or terminal block for power wiring
- External location available for mounting a fused disconnect device
- Choice of electromechanical or microprocessor controls

### Electromechanical

- 24-volt control circuit shall include control transformer and contactor pressure lugs for power wiring
- Units shall have single point power entry as standard

### Microprocessor

- 24V control functions
- Resident control algorithms shall make all heating, cooling, and/or ventilating decisions in response to electronic signals from sensors measuring indoor and outdoor temperatures
- Control algorithm maintains accurate temperature control, minimizes drift from set point, and provides better building comfort
- Anti-short cycle timing and time delay between compressors provide a higher level of machine protection

## Filters

- Standard throwaway filters
- Optional 2-inch MERV 8 and MERV 13 filters

## Gas Heating Section

- Progressive tubular heat exchanger, stainless steel burners and corrosion resistant steel
- Induced draft combustion blower shall be used to pull the combustion products through the firing tubes
- Heater shall use a direct spark ignition (DSI) system
- On initial call for heat, the combustion blower shall purge the heat exchanger for 20 seconds before ignition
- After three unsuccessful ignition attempts, entire heating system shall be locked out until manually reset at the thermostat/zone sensor
- Units shall be suitable for use with natural gas or propane (field-installed kit)
- (3 to 5 tons only) For installation in SCAQMD only: This furnace does not meet the SCAQMD Rule 1111 14 ng/J NO<sub>x</sub> emission limit, and thus is subject to a mitigation fee of up to \$450. This furnace is not eligible for the Clean Air Furnace Rebate Program: [\[Either the href or the keyref attribute should be set on xref elements\]](#) [www.cleanairfurnacerebate.com](http://www.cleanairfurnacerebate.com)

## Indoor Fan

- Direct drive plenum fan design – 10 tons, 6 ton (074), 7.5 to 8.5 ton high efficiency units, and optional on 7.5 ton (092) to 8.5 ton standard efficiency units



## Mechanical Specifications

---

- Plenum fan design — backward-curved fan wheel along with an external rotor direct drive variable speed indoor motor
- Plenum fan design — variable speed adjustment potentiometer located in the control box
- Belt drive units – 3 to 5 ton units (high efficiency 3-phase with optional motor) and 6 to 8.5 tons, standard efficiency
- Multispeed, direct drive motors — FC centrifugal fans with adjustable motor sheaves. 3 to 5 ton units (standard and high efficiency)
- Motors thermally protected.
- Variable speed direct drive motors — 10 tons, 6 ton (074), 7.5 to 8.5 (high efficiency)
- Indoor fan motors meet the U.S. Energy Policy Act of 1992 (EPA)

### Outdoor Fan

- Direct-drive, statically balanced, draw-through in the vertical discharge position
- Permanently lubricated, built-in thermal overload protection included

### Phase Monitoring Protection

- 3-phase power equipped with phase monitoring protection as standard
- Protect motors and compressors against problems caused by phase loss, phase imbalance and phase reversal indication

### Refrigerant Circuits

- Thermal expansion valve standard
- Service pressure ports, and refrigerant line filter driers factory-installed standard
- Area provided for replacement suction line driers

### Unit Top

- One piece construction or where seams exist, it shall be outside the indoor air-conditioned section
- Ribbed top adds extra strength and prevents water from pooling

## Factory Installed Options

### Black Epoxy Pre-Coated Coils

- Thermoset vinyl coating
- Bonded to aluminum fin stock (prior to the fin-stamping process)
- Economical option for protection in mildly corrosive environments

*Note: Not available on microchannel condenser coils*

### CO<sub>2</sub> Sensor Wiring

- Factory-installed CO<sub>2</sub> sensor wiring saves time and ensures proper unit connections for field installed CO<sub>2</sub> sensor kits

### CompleteCoat™ Coils

- Cathodic epoxy type electro-disposition coating formulated for high edge build to plate fin and tube heat exchangers
- Coating provides excellent resistance and durability to corrosive effects of alkalies, acids, alcohols, petroleum, seawater, salt air and corrosive environments
- Option is available for the plate fin-tube condenser coil and the microchannel type condenser coil

### Condensate Overflow Switch

- If a clogged condensate drain line is preventing proper condensate removal from the unit this option will shut the unit down

## Heat Exchanger

- Compact cabinet features a tubular heat exchanger in low, medium and high heat capacities
- Corrosion-resistant aluminized steel tubes and burners are standard on all models
- Induced draft blower to pull the gas mixture through the burner tubes
- Direct spark ignition system doubles as a safety device to validate the flame

## Hinged Access Doors

- Sheet metal hinges available on the filter/evaporator, supply fan/heat, and the compressor/control access doors

## Human Interface

- 5 inch color touchscreen display that conforms to FCC Part 15 Class B with an Ingress Protection Rating of IP24
- Display text shall be readable by a person with 20/20 vision at a distance of 3 feet and 60° angle at lighting levels ranging from 100 lux - 25,000 lux
- Display shall operate at temperatures of -40° C to 70° C
- Firmware and unit configurations shall be able to be restored via a USB storage device

## Fault Detection & Diagnostics (FDD)

- Meets the mandatory requirement of CA Title 24 of fully configured diagnostics allowing fault history and reading fault codes at the unit
- Provides detection of the following faults: Air temperature sensor failure/fault and notification of acceptable economizer mode
- FDD system shall be certified by the Energy Commission as meeting the requirements

## Novar Return Air Sensor

- When used in conjunction with Novar Controls, this option contains a factory provided and wired zone temperature sensor located in the return air stream

## Novar Controls

- Shall be installed and tested
- Electronic thermostat module will interface to the unit microprocessor and control the unit to the desired stage of cooling or heating

## Powered or Unpowered Convenience Outlet

- Powered or unpowered GFCI, 120V/15amp, 2 plug, convenience outlet
- When convenience outlet is powered, a service receptacle disconnect will be available
- Convenience outlet is powered from the line side of the disconnect or circuit breaker, and therefore will not be affected by the position of the disconnect or circuit breaker
- Available to order when through-the-base electrical with disconnect switch or circuit breaker option is ordered

## Multi-Speed Indoor Fan System

- Automatically switch operation of the indoor fan between high speed and low speed, based on the number of compressors operating
- Operate at high speed whenever the gas or electric heater is operating

## Multi-Zone VAV Control

- To maintain the duct static pressure at a setpoint, control shall vary the speed of the indoor fan
- Cooling mode — compressors shall cycle (or economizer shall modulate) to maintain supply air temperature (SAT) at desired setpoint
- Heating mode — indoor fan shall operate at maximum speed when heater is operating
- VAV units cannot be controlled by a thermostat



## Mechanical Specifications

---

### Single Zone VAV – One Zone Variable Air Volume Mode

- As zone cooling or heating load changes, indoor fan speed will vary
- Cooling capacity is cycled to maintain the supply air temperature at setpoint
- Indoor fan shall operate at maximum speed whenever heater operating

**Notes:**

- *Requires the use of a zone temperature sensor*
- *If a unit is configured for SZVAV, but connected to a conventional thermostat, the unit will revert to multiple-speed (two-speed) indoor fan control*

### Stainless Steel Drain Pan

- Corrosion and oxidation resistance
- Reversible and constructed of 304 stainless steel

### Stainless Steel Heat Exchanger

- Constructed of 409 stainless steel tubes and 439 stainless steel burners
- Resistant to corrosion and oxidation and easy to clean
- High strength to weight ratio allows for high ventilation rates with gas units
- Compliment dehumidification option as a high outside air ventilation unit
- 10-year stainless steel heat exchanger warranty is standard.

### Supply, Return and Plenum Air Smoke Detector

- All unit operation will shut down if smoke is detected
- Reset manual at unit
- In order for supply or return air smoke detector to properly sense smoke in the supply/return air stream, entering air velocity must be between 500 - 4000 feet per minute
- Equipment covered in this manual will develop an airflow velocity that falls within these limits over the entire airflow range specified in the evaporator fan performance table
- Supply and/or return smoke detectors may not be used with plenum smoke detector

### Through-the-Base Electrical Access

- Electrical access for control and main power connections inside the curb and through-the-base of the unit
- Field installation of liquid-tight conduit
- External field-installed disconnect switch

### Through-the-Base Electrical with Circuit Breaker

- Thermal magnetic, molded case, HACR circuit breaker with provisions for through-the-base electrical connections
- Circuit breaker installed within unit in water tight enclosure
- Access through a swinging door
- Wiring provided from the switch to the unit high voltage terminal block
- Circuit breaker will provide overcurrent protection, sized per NEC and cULus guidelines, and agency recognized by cULus

### Through-the-Base Electrical with Disconnect Switch

- 3-pole, molded case, disconnect switch with provisions for through-the-base electrical connections
- Disconnect switch installed within unit in a water tight enclosure
- Access through a swinging door
- Wiring provided from the switch to the unit high voltage terminal block
- Switch cULus agency recognized

**Note:** *Disconnect switch sized per NEC and cULus guidelines but will not be used in place of unit overcurrent protection*

## Through-the-Base Gas Piping

- Unit shall include a standard through-the-base gas provision
- All necessary piping including, black steel, manual gas shut-off valve, elbows, and union
- Manual shut-off valve shall include a 1/8" NPT pressure tap
- Assembly will require minor field labor to install (gas/electric only)

## Two-Inch Filters

- Two-inch MERV 8 and MERV 13 media filters available on all models

## Factory or Field Installed Options

### Clogged Filter/Fan Failure Switch

- Dedicated differential pressure switch available to achieve active fan failure indication and/or clogged filter indication
- Registered with either a zone sensor with status indication lights or an Integrated Comfort System
- Available for microprocessor controlled units

### Discharge Air Temperature Sensing

- Provides true discharge air temperature sensing in heating models.
- Readable through Tracer® or Tracker™.
- Functional only with the ReliaTel™ options module.

### Economizer (Standard)

- Available with or without barometric relief.
- Fully modulating 0-100 percent motor and dampers, minimum position setting, preset linkage, wiring harness with plug, spring return actuator and fixed dry bulb control
- Barometric relief shall provide a pressure operated damper that shall be gravity closing
- Barometric relief shall prohibit entrance of outside air during the equipment "off" cycle
- Optional solid state or differential enthalpy control
- Arrives in shipping position and shall be moved to the operating position by the installing contractor

### Electric Heaters

- Constructed of heavy-duty nickel chromium elements internally delta connected for 240V, wye connected for 480V and 600V
- Staging achieved through ReliaTel™
- Automatically reset high limit control operating through heating element contactors
- Heaters individually fused from the factory
- Shall meet all NEC and CEC requirements when properly installed
- Power assemblies shall provide single-point connection
- Modules shall be cULus listed

### Frostat™

- Utilized as a safety device
- Opens when temperatures on evaporator coil fall below 10°F
- Temperature will need to rise to 50°F before closing
- Utilized in low airflow or high outside air applications (cooling only)



## Mechanical Specifications

---

### Low Leak Economizer

- Meets low leak requirements for ASHRAE 90.1, IECC, and CA Title 24 standards (3 cfm/ft<sup>2</sup>@1" wg exterior air, 4 cfm/ft<sup>2</sup>@1" wg return air)
- 100% outdoor air supply from 0-100% modulating dampers
- Standard with barometric relief
- Can be paired with powered exhaust for additional building pressure relief
- Can be paired with or without Fault Detection & Diagnostics (FDD) to meet current mandatory CA Title 24 requirements
- Available on downflow units only
- Economizers come with three control options, dry bulb and reference or comparative enthalpy (optional)

### Reference or Comparative Enthalpy

- Reference enthalpy used to measure and communicate outdoor humidity
- Unit receives and uses information to provide improved comfort cooling while using the economizer
- Comparative enthalpy measures and communicates humidity for both outdoor and return air conditions, and return air temperature
- Unit receives and uses information to maximize use of economizer cooling, and to provide maximum occupant comfort control
- Reference or comparative enthalpy available when a factory or field installed downflow economizer ordered
- Option is available on all downflow models

### Hail Guards

- Available for condenser coil protection

### Field Installed Options

#### CO<sub>2</sub> Sensor

- Ability to monitor the concentration (parts per million, ppm) of CO<sub>2</sub> (Carbon Dioxide) in the air.
- As CO<sub>2</sub> concentration changes, outside air damper modulates to meet the current ventilation needs of the zone
- Two field installed kits are offered; CO<sub>2</sub> sensor and wiring or CO<sub>2</sub> sensor only
- CO<sub>2</sub> sensor only kit should be ordered with factory installed CO<sub>2</sub> sensor wiring

#### High Static Drive

- High static drive shall allow the standard motor to operate with improved external static capabilities

### Low Leak Economizer

- Meets low leak requirements for ASHRAE 90.1, IECC, and CA Title 24 standards (3 cfm/ft<sup>2</sup>@1" wg exterior air, 4 cfm/ft<sup>2</sup>@1" wg return air)
- 100% outdoor air supply from 0-100% modulating dampers
- Standard with barometric relief
- Can be paired with powered exhaust for additional building pressure relief
- Available on downflow units only