



## Heating and Air Conditioning

### TECHNICAL GUIDE

**R-410A  
SPLIT-SYSTEM  
AIR-COOLED CONDENSING UNITS  
AND AIR HANDLERS**

### PREDATOR® SERIES

**YC090-240 and YD120-240  
CONDENSING UNIT MODELS**

**PC090-240 and PD180-240  
HEAT PUMP UNIT MODELS**

**NC090-240 and ND120-240  
AIR HANDLING UNIT MODELS**

**7.5 - 20 Ton  
60 Hertz**

### Description

Predator® condensing units and heat pumps are completely assembled, piped and wired at the factory to provide a single-piece unit for shipment and rigging. Each unit is pressurized with a holding charge of refrigerant R-410A for storage and/or shipping.

The compact design, clean styling, small footprint, and quiet operation make these condensing units and heat pumps suitable for almost any outdoor location. On rooftops... because they weigh much less than a single package unit of similar capacity and are much easier to rig and support. On the ground... because the footprint is compact allowing a variety of applications.

Both the Predator® condensing units and heat pumps are equipped with reliable Simplicity® microprocessor controls to assure proper operation and unit protection for long product life. Products from 10 to 20 tons are available in single or dual (2 or 4 pipe) refrigerant circuits for redundancy in operation and various application choices such as one outdoor unit matched with two indoor units.

The Predator® air handling units are completely assembled units, including a well-insulated cabinet, a DX cooling coil with copper tubing, aluminum fins, expansion valve(s), distributor(s), 2" throwaway filters, a centrifugal blower, a blower motor, an adjustable belt drive, a blower motor contactor and a small holding charge of refrigerant R-410A.

Units are shipped in the vertical position ready for field installation, but can be easily converted to horizontal position. An added benefit of the Predator® air handling units is they are designed to operate with either a condensing unit or a heat pump and no field modification or special unit is required for heat pump applications.

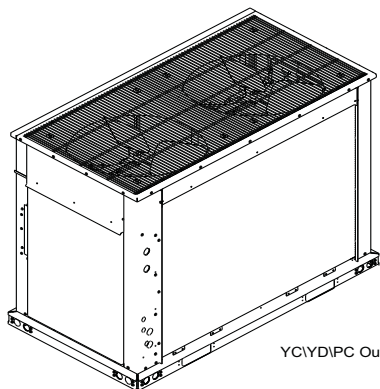

YD\YD\PC Outdoor Units

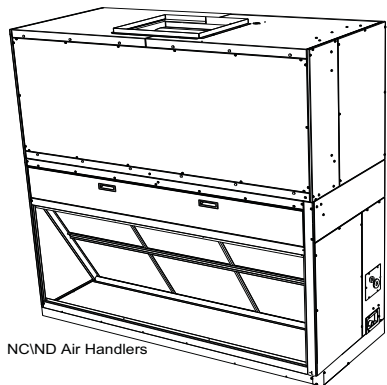

NC\ND Air Handlers

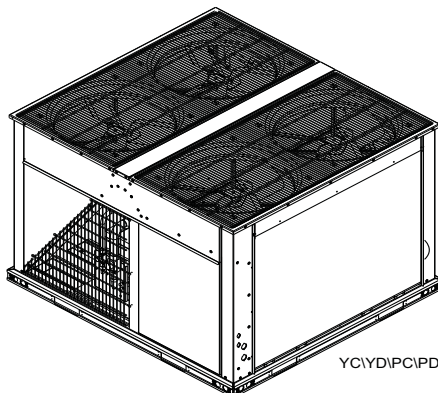

YD\YD\PC\PD Outdoor Units



ISO 9001  
Certified Quality  
Management System

## Table of Contents

<b>Description</b> .....	1
<b>Table of Contents</b> .....	2
<b>Nomenclature</b> .....	3
<b>Condensing Unit Features and Benefits</b> .....	4
<b>Outdoor Unit Accessories</b> .....	4
<b>Air Handling Unit Features and Benefits</b> .....	5
<b>Guide Specifications</b> .....	6
<b>Physical Data</b> .....	9
<b>Unit Limitations</b> .....	12
<b>Cooling and Heating Ratings</b> .....	14
<b>Capacity Performance</b> .....	15
<b>Airflow Performance</b> .....	61
<b>Sound Performance</b> .....	70
<b>Electrical Data</b> .....	71
<b>Typical Wiring Diagrams</b> .....	77
<b>Weights And Dimensions</b> .....	88

## Nomenclature

### Configured Split Condenser Model Number Nomenclature

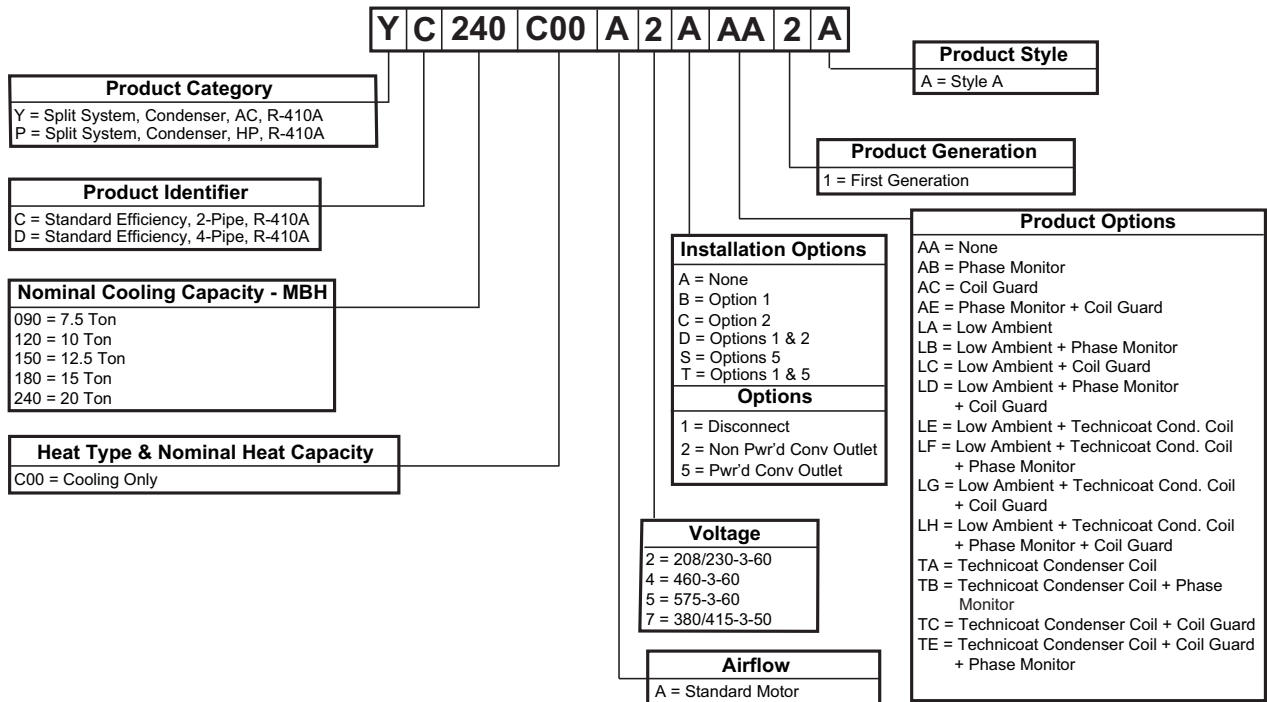

### Configured Split Air Handler Model Number Nomenclature

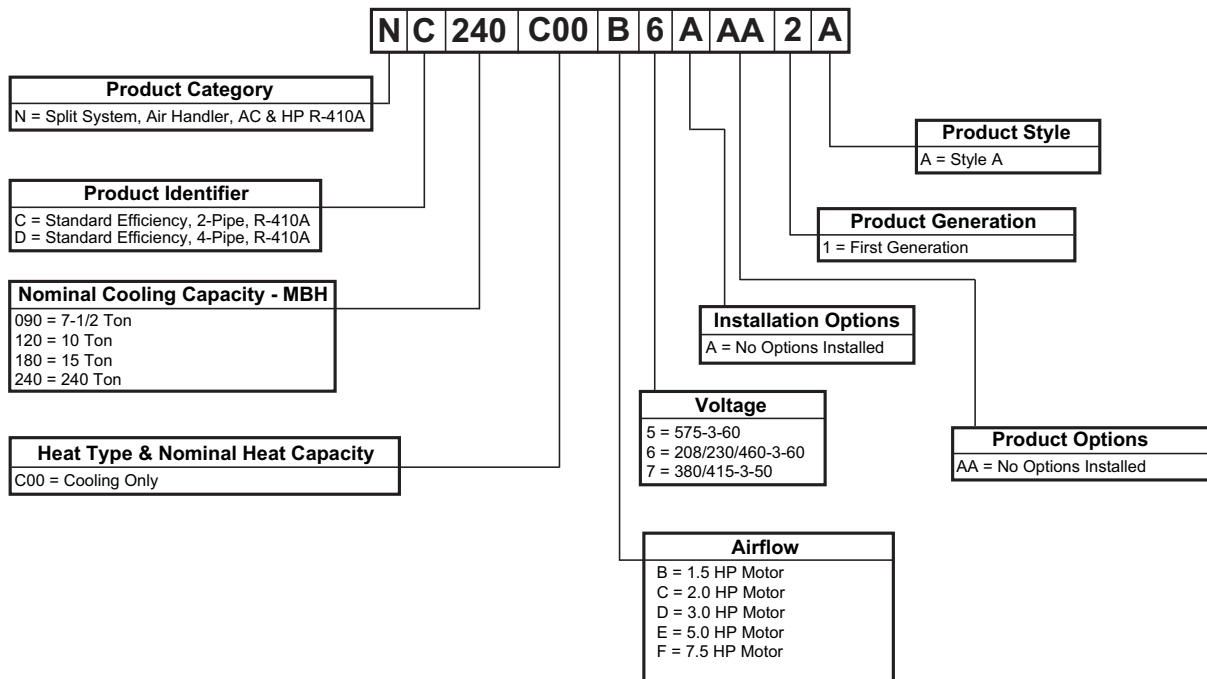

## Condensing Unit Features and Benefits

### Features

- Meets or exceeds ASHRAE 90.1 standards.
- Scroll compressors provide both high efficiency and reliability.
- Simplicity® Controls
- Dual refrigerant circuits on PD and YD models.
- Condensing unit coils are constructed of reliable and durable Micro-Channel aluminum tube and fins for long lasting, efficient operation. Micro-Channel technology provides exceptional durability along with reduced product weight and less refrigerant charge. Heat pumps units are equipped with aluminum fin, copper tube coils providing durability, reliability and value.
- Multiple condensing unit and air handler match-ups provide a wide range of application choices from oversized indoor motors to dual indoor units matched-up with single outdoor units.
- Crankcase heaters that will be de-energized when compressors are operating.
- Both high and low pressure controls. Since these controls are self-contained, there are no capillary lines to be damaged.
- Internal compressor motor protection.
- Class 2, 24-volt thermostat control circuit protected by a re-settable breaker.
- Standard factory installed service valves.
- Filter-driers are shipped in the unit's control box for field installation in the liquid line leaving the outdoor unit.
- Copper stub-outs are factory mounted on the suction and liquid lines to simplify the field piping connections.
- Simplicity® Controls provide stable cooling operation at ambient temperatures down to 40°F with low ambient kits available for operation to 0°F.
- Capacity staging for more economical operation and stable temperature levels within the conditioned space.
- Simplicity® Controls prevent the unit from cycling on safety control with "Three Outs" technology preventing nuisance trips, but protecting the equipment when valid operational issues are experienced.
- Simplicity® Controls monitor each safety independently (High pressure, low pressure, low voltage) allowing ease of troubleshooting if any problems arise.
- Inherently protected condenser fan motors.
- Technicoated outdoor coils for sea coast or corrosive environment applications.
- Factory installed disconnect to allow power to be removed from the unit when performing periodic maintenance or for service.

- Factory installed powered or non-powered 115 volt GFI outlet.
- Factory installed phase monitor to protect the unit from phase loss or phase reversal.

### Benefits

The Predator® condensing units and heat pumps can be applied on a rooftop or at ground level... due to their ample sub-cooling capacity which allows them to be located three or more stories below the evaporator coil.

After assembly, the unit is pressurized with a combination of Refrigerant R-410A and nitrogen for pressure testing and additional leak testing. During this pressure test, the operation of the high pressure control is checked. As the unit is being evacuated and dehydrated, the operation of the low pressure control is also checked.

Every compressor, condenser fan motor, crankcase heater, and electrical control circuit is checked to assure a trouble-free start-up and years of reliable operation. The condenser fan guards are vinyl-coated to provide additional rust protection and to enhance the appearance of the unit. Compressors are mounted on rubber isolators to reduce the transmission of vibration. Vertical discharge condenser fans direct sound upward and away from any surrounding structures.

All sheet metal parts are constructed of commercial grade galvanized steel. After fabrication, each part is thoroughly cleaned to remove any grease or dirt from its surfaces. The external parts are coated with a powder paint to assure a quality finish for many years. This UL approved coating system has passed the 1000 hour, 20% salt spray test per ASTM Standard B117.

All condensing unit and heat pump models include a 5-year limited warranty on the compressor(s) and 1-year limited warranty on all other parts. The matching line of air handling units carries a 1-year limited parts warranty.

### Outdoor Unit Accessories

Coil Guards: Wireform coil guards for added protection of outdoor coils. Designed to mount on each side of the product if required to provide protection from minor impacts or large debris.

Hail Guards: Hood type hail guards designed to protect the outdoor coils from hail. Can be installed on a single side or both to provide protection from storms that may produce hail.

Low Ambient Kits: Kits designed to allow the cooling only units to operate between 0°F and 40°F in the cooling mode. Standard cooling is allowed to 40°F. (Not designed for operation on heat pump units).

## Air Handling Unit Features and Benefits

### Features

These air handlers can be arranged for a variety of air discharge patterns in either the horizontal or vertical position. Refer to the unit installation instructions for other application possibilities.

### Benefits

Air handling units are designed with two distinct modules to provide maximum application flexibility. All are shipped as single packages with the blower module mounted on top of the coil module. The blower module can be repositioned in the field to meet a large number of vertical and horizontal applications.

The blower module includes the blower wheels along with factory-mounted motor and drive. All models offer two motor horsepower options to meet both standard and high static airflow requirements. The coil module includes direct expansion coils, 2 in. throwaway filters with the option to accept 4" filters, liquid line solenoid valves for capacity reduction, thermal expansion valves, distributors and a non-corrosive, composite condensate drain pan.

Every air handling coil is pressurized with air and leak tested under water. After the headers are brazed onto the coil and the coil is installed in the unit, the coil is pressurized with a combination of Refrigerant R-410A and nitrogen for pressure testing and additional leak testing. After the coil is evacuated and dehydrated, it is pressurized with a holding charge of Refrigerant R-410A for storage and/or shipping.

These air handlers, combined with condensing units, provide years of quiet, efficient and dependable operation. These units are manufactured under ISO 9001 Quality System Certification.

### Unit Installation

Units may be bottom-supported or ceiling-suspended and can be arranged to meet almost any space or duct requirements. Each unit is available with a choice of blower motors horsepower and other accessories to make them suitable for most applications.

**Blower Motors:** Different HP motors are available for each unit to meet almost any air delivery requirement. All motors are UL approved, have permanently lubricated ball bearings and are factory-mounted within the insulated cabinet of the units to minimize the transmission of sound to the surrounding space.

Air Handling units are available in either two or four pipe configurations from 7.5 to 20 tons. The dual and single circuit options provide a wide variety of application and unit match-up possibilities.

### Factory-Mounted Components

**Part Load Operation:** These air handlers with DX (Direct Expansion) coils rated at 10 tons of capacity and above have multiple coils with pre-piped distributors, expansion valves and solenoid valves. Field modifications are not required for part load operations. Capacity reduction not only provides economical operation, but also maintains stable temperature and humidity levels in the conditioned space.

**Easy Service:** Serviceable expansion valves are provided on every unit. These valves are factory-installed to provide many years of trouble-free operation. If service is required, it is not necessary to unbrazed any joints. The expansion valves also include a tee fitting to allow easy installation of hot gas bypass if required.

**Coil Protection:** The indoor coils of these air handlers can be factory Technicoated to provide extended life to the indoor coil in standard applications and additional corrosion protection on those applications in sea coast or corrosive environments.

**Blower Motors:** Different HP motors are available for each unit to meet almost any air delivery requirement. 1.5-5 HP motors are inherently protected. 7.5 HP will come equipped with a motor starter and overload protection.

### Accessories

**Base Sections:** Base sections can be used to elevate units above the floor. If desired, a moderate percentage of outdoor air may be introduced through these sections by cutting an access opening to accommodate the outdoor air duct connection. These bases include a durable finish to match the evaporator blower unit. The base may have to be insulated for certain applications.

**Hot Water Coils:** Drainable water coils are available for field installation between the blower and the coil modules of both horizontal and vertical units. Since their casings match the dimensions and the finish of the basic units, they become an integral part of the unit after installation. The coils slide out of their casings for easy installation. Hot water coils have copper tubes that have been mechanically expanded into aluminum fins. Both headers are located on the same end of the coil. Coils are leak-tested at 325 psig under water and dried before their connections are capped for storage and shipping.

**Steam Coils:** Steam coils are available for installation between the blower and coil modules of both horizontal and vertical units. Since the casing matches the dimensions and the finish of the basic unit, it becomes an integral part of the unit after installation. The coil slides out of the casings for easy installation and is pitched in the casings to facilitate condensate drainage. The coil has copper tubes that have been mechanically expanded into aluminum fins. Both headers are located on the same end of the coil. The coil is leak-tested at 325 psig and dried before the connections are capped for storage and shipping.

## Guide Specifications

### Split System Cooling Only Condensing Units Models: YC090-240, YD120-240 & Split System Heat Pump Models: PC090-240, PD180-240

#### General

- Factory assembled, single piece, air cooled condensing unit designed for outdoor installation.
- Factory wired, piped, and tested for leakage and functionality to assure trouble-free installation and start-up.
- Rated in accordance with ARI Standard 340/360.
- Manufactured in a facility registered under the ISO 9002 manufacturing quality standard.
- Designed and tested in accordance with ASHRAE 15 Safety Code for Mechanical Refrigeration and comply with NEC.
- Cooling performance rated in accordance with DOE and ARI test procedures.
- CSA listed and classified to UL 1995/CAN/CSA No. 236- M90 standards.
- One year limited parts warranty on complete unit with an additional four year compressor warranty.

#### Unit Operating Characteristics

Operating Range shall be between 125° F to 40° F in cooling as standard from factory.

- The capacity of the condensing unit shall meet or exceed \_\_\_\_\_ Btuh at a suction temperature of \_\_\_\_\_ F. The power consumption at full load shall not exceed \_\_\_\_\_ kW.
- The combination of the condensing unit and the evaporator or fan coil unit shall have a total net cooling capacity of \_\_\_\_\_ Btuh or greater at conditions of \_\_\_\_\_ cfm entering-air temperature at the evaporator at \_\_\_\_\_ F wet bulb and \_\_\_\_\_ F dry bulb, and air entering the condensing unit at \_\_\_\_\_ F.
- The system shall have an EER of \_\_\_\_\_ Btuh/ Watt or greater at standard ARI conditions.

#### Installer Shall

- Furnish York® air-cooled condensing units, heat pump or equivalent in accordance with the performance schedule shown on the plans, and
- Unit shall be stored and handled in accordance with unit manufacturer's instructions.
- Install each unit as shown on the plans in accordance with the manufacturer's recommendations and all applicable national and local codes

#### Unit Construction

- Constructed of zinc-coated, galvanized steel.
- Exterior surfaces bonded and coated with baked enamel finish by a powder paint process capable of withstanding a minimum of 1000 salt spray hours according to ASTM B117.
- Cabinet screws that comply with ASTM B117 salt spray test for a minimum of 750 hours.
- Permanently attached heavy-gage perimeter base rails with forklift slots and lifting holes.
- Removable access panels to all internal components.
- Separate access panel to controls.
- Access panels to allow outdoor coil cleaning.

#### Compressor(s)

- Hermetic scroll type, internally protected with high-pressure relief and over temperature protection.
- Two stage units operate in 50% capacity increments.
- Suction gas cooled
- Voltage range of  $\pm 10\%$  of unit nameplate voltage.
- Neoprene isolators minimize sound transmission and vibration.
- Belly-band crankcase heaters keep refrigerant from diluting sump oil.
- Full charge of compressor oil

#### Outdoor Condenser Unit Coils

- Draw thru configuration
- Constructed with Micro-channel aluminum fins and aluminum tubing. All refrigerant tubing must share a common header.

#### Heat Pump Unit Outdoor Unit Coils

- Draw thru configuration
- Constructed with aluminum plate fins mechanically bonded to seamless internally enhanced copper tubes with all joints brazed.

#### Condenser Fans

- Direct driven propeller-type fans
- Statically and dynamically balanced
- Aluminum blades riveted to corrosion resistant steel spider brackets.
- Arranged for vertical air discharge.
- Equipped with PVC coated steel wire safety guards.

#### Condenser Motors

- Totally enclosed, air over cooled.
- Inherent overload protection.
- Permanently lubricated bearings.

- Must cycle to allow cooling operation down to 40°F.

### Refrigerant Piping

- Solid core filter-drier(s) ship loose for field installation.
- Liquid and suction line service valves with gauge ports.
- Suction and discharge line service ports accessible from unit. Ports capped for leak prevention.
- Liquid line magnetic check valves
- Holding charge of R410A refrigerant.

### Electrical Requirements

- Single-point connection electrical power.
- Nominal unit electrical characteristics shall be \_\_\_\_\_ v, 3-ph, 60 Hz. The unit shall be capable of satisfactory operation within voltage limits of \_\_\_\_\_ v to \_\_\_\_\_ v.
- Condenser fan motors and secondary of transformers shall be grounded.

### Unit Controls

- All 24-volt control circuit, powered by a 24 volt transformer(s) and protected by a resettable breaker.
- Conventional thermostat must provide operation for both condensing units and heat pumps without an "O" output from the thermostat.
- Low voltage terminal strip for simple hook-up.
- Compressor motor protection shuts down unit for motor over-current, over-temperature or low voltage conditions.
- Safety lockouts provide reset capability at the space thermostat or base unit should any of the following standard safety devices trip and shut off compressor:
  - a. Loss-of-charge/Low-pressure switch.
  - b. High-pressure switch.
  - c. Control board diagnostics and fault code display.
  - d. Safety lockouts send a 24 volt signal to the control board's "X" terminal, allowing notification to the user via the thermostat fault light (if present).
  - e. Control board shall retain last 5 fault codes in non-volatile memory, which will not be lost in the event of a power loss. An LED (light-emitting diode) indicator flashes a fault code that indicates which safety switch has tripped.

### Non-fused Disconnect Switch

- Factory-installed, internally mounted.
- Accessible from outside the unit.
- NEC and UL approved non-fused switch.
- Provides power off lockout capability.

### Convenience Outlet

- Factory-installed, internally mounted.
- Accessible from outside the unit.
- 115V, 15 amp GFI receptacle with independent fuse protection.
- Required voltage provided by factory-installed step-down transformer or field supplied 115v circuit.

### Low-ambient Head Pressure Control

- Standard operation down to 40 °F without a low ambient kit.
- Operation down to 0°F with a field-installed low ambient kit accessory. The controller modulates the fan motor speed in response to liquid line temperature or pressure.

### Coil Guard

Factory or field installed decorative grille shall be placed on the units to protect condenser coil after installation.

### Hail Guard Package

Field installed hail guard package shall protect coils against damage from hail and other flying debris.

### Phenolic Coated Condenser Coils

Special phenolic coating available as a factory option on both outdoor and indoor coils.

### Each Unit Shall Be:

- Covered by a 1-year limited parts warranty on the complete unit and 5-year on compressor(s).
- In current production with published literature available to check performance, limitations, specifications, power requirements, dimensions, operation and appearance.
- Indoor unit shall be equipped with a V-belt drive option that will permit the blower RPM to be adjusted to meet the CFM requirements of the air delivery system. (Refer to Technical Guide for Airflow Capabilities.)

### Each Unit Enclosure Shall Have:

- Exterior panels of 18 gauge steel, finished with baked enamel to provide a long lasting quality appearance
- Removable panels to provide easy access to the internal components for maintenance and service on condensing units, heat pumps and air handlers
- All handling units must have a filter rack that accepts both 2" and 4" filters.
- The dimensions of each unit shall not exceed those specified in the manufacture's literature.

- The minimum application clearances for condensing units, heat pumps and air handlers must meet those specified in the manufacturer's literature.

**The Blower Motor Shall:**

- Be mounted within the insulated cabinet to minimize the transmission of sound to the surrounding space, and any motor 7.5 HP or greater must have a service factor of 1.15.

**The Evaporator Coil Shall:**

- Consist of copper tubes arranged in staggered rows, mechanically expanded into aluminum fins,
- Be draw-through, and
- Include factory-mounted distributors, expansion valves and solenoid valves for capacity reduction.

**The Blower Wheels Shall:**

Be dynamically balanced to minimize the levels of sound and vibration generated by the unit.



**PC090 - 240 and PD180 - 240 Physical Data**

Component	Nominal Tonnage	Models					
		PC090	PC120	PC180	PD180	PC240	PD240
<b>REFRIGERANT</b>							
Refrigerant type		R-410A	R-410A	R-410A	R-410A	R-410A	R-410A
Holding charge (lb) <sup>1</sup>		1.0	1.0	1.0	1.0	1.0	1.0
Operating Charge (lb) <sup>2</sup>	System #1	16.1	23.3	35.7	17.9	44.2	22.1
	System #2	---	---	---	17.9	---	22.1
<b>DIMENSIONS (inches)</b>							
Length		59.1	59.1	59.1	59.1	59.1	59.1
Width		31.9	31.9	64.1	64.1	64.1	64.1
Height		44.5	50.0	44.5	44.5	50.0	50.0
<b>WEIGHTS (lb)</b>							
Shipping		405	550	815	810	985	980
Operating		415	560	840	835	1010	1005
<b>COMPRESSORS</b>							
Type		Single Scroll	Tandem Scroll	Tandem Scroll	Single Scroll	Tandem Scroll	Tandem Scroll
Quantity		1	1	1	2	1	2
Nominal Capacity (Tons)	System #1	7.5	10	15	7.5	20	10
	System #2	---	---	---	7.5	---	10
Capacity Stages	System #1	1	2	2	1	2	1
	System #2	---	---	---	1	---	1
<b>SYSTEM DATA</b>							
No. Refrigeration Circuits		1	1	1	2	1	2
Suction Line OD (in.)		1 1/8	1 3/8	1 5/8	1 1/8	1 5/8	1 3/8
Liquid Line OD (in.)		5/8	7/8	7/8	5/8	7/8	7/8
<b>OUTDOOR COIL DATA</b>							
Face area (Sq. Ft.)		23.75	29.03	29.03	29.03	47.5	47.5
Rows		2	2	2	2	2	2
Fins per inch		20	20	20	20	20	20
Tube diameter (in./MM)		0.38 / 10	0.38 / 10	0.38 / 10	0.38 / 10	0.38 / 10	0.38 / 10
Circuitry Type		Interlaced	Interlaced	Interlaced	Interlaced	Interlaced	Interlaced
Refrigerant Control		TXV	TXV	TXV	TXV	TXV	TXV
<b>CONDENSER FAN DATA</b>							
No. Fans / Diameter (in.)		2/24	2/24	2/24	2/24	4/24	4/24
Type		Axial	Axial	Axial	Axial	Axial	Axial
Drive type		Direct	Direct	Direct	Direct	Direct	Direct
No. speeds		1	1	1	1	1	1
Number of motors	System #1	2	2	4	2	4	2
	System #2	---	---	---	2	---	2
Motor HP (ea.)		1/3	3/4	1/3	1/3	3/4	3/4
Rotation <sup>3</sup>		CW	CW	CW	CW	CW	CW
RPM		850	1100	850	850	1100	1100
Nominal CFM	System #1	7500	9800	15000	7500	19600	9800
	System #2	---	---	---	7500	---	9800

## Unit Limitations

### Condenser Unit limitations

Size (Tons)	Model	Unit Voltage	Applied Voltage <sup>1</sup>		Outdoor DB Temp Cooling (°F)		Indoor DB Temp Cooling (°F)		Outdoor DB Temp Heating (°F)		Indoor DB Temp Heating (°F)	
			Min	Max	Max	Min <sup>†</sup>	Max	Min	Max	Min	Max	Min
090 (7.5)	PC	208/230-3-60	187	252	125	40	86	68	70	0	80	50
		460-3-60	432	504								
		575-3-60	540	630								
090 (7.5)	YC	208/230-3-60	187	252	125	40	86	68	-	-	-	-
		460-3-60	432	504								
		575-3-60	540	630								
120 (10)	PC	208/230-3-60	187	252	125	40	86	68	70	0	80	50
		460-3-60	432	504								
		575-3-60	540	630								
120 (10)	YC/YD	208/230-3-60	187	252	125	40	86	68	-	-	-	-
		460-3-60	432	504								
		575-3-60	540	630								
150 (12.5)	YC/YD	208/230-3-60	187	252	125	40	86	68	-	-	-	-
		460-3-60	432	504								
		575-3-60	540	630								
180 (15)	PC/PD	208/230-3-60	187	252	125	40	86	68	70	0	80	50
		460-3-60	432	504								
		575-3-60	540	630								
180 (15)	YC/YD	208/230-3-60	187	252	125	40	86	68	-	-	-	-
		460-3-60	432	504								
		575-3-60	540	630								
240 (20)	PC/PD	208/230-3-60	187	252	125	40	86	68	70	0	80	50
		460-3-60	432	504								
		575-3-60	540	630								
240 (20)	YC/YD	208/230-3-60	187	252	125	40	86	68	-	-	-	-
		460-3-60	432	504								
		575-3-60	540	630								

1. Rated in accordance with ARI Standard 110, Range "A" Utilization Voltage.

†. Low Ambient accessories are available to permit stable system operation at ambient temperatures down to 0°F.

## Cooling and Heating Ratings

### Cooling And Heating Rating

Outdoor Unit	Condensing Unit Only			Indoor Unit	System Cooling Capacity <sup>1</sup>				Heating Capacity <sup>1</sup>				Rated Airflow (CFM)
	Gross Capacity <sup>2</sup> (MBH)	KW	EER		Gross Capacity <sup>3</sup> (MBH)	EER	IEER	IPLV	High Outdoor		Low Outdoor		
									Gross Capacity <sup>2</sup> (MBh)	COP	Gross Capacity <sup>2</sup> (MBh)	COP	
PC120 <sup>4</sup>	N/A	N/A	N/A	NC090	92	11.0	11.4	---	82	3.3	49	2.3	3000
PC120 <sup>4</sup>	N/A	N/A	N/A	NC120	124	11.0	11.4	11.8	109	3.3	63	2.1	4000
PC180 <sup>4</sup>	N/A	N/A	N/A	NC180	180	10.6	11.5	12.4	168	3.3	104	2.3	6000
PD180 <sup>4</sup>	N/A	N/A	N/A	ND180	180	10.6	11.5	12.0	168	3.4	103	2.4	6000
PC240 <sup>4</sup>	N/A	N/A	N/A	NC240	238	10.6	12.4	12.5	216	3.3	139	2.5	8000
PD240 <sup>4</sup>	N/A	N/A	N/A	ND240	238	10.6	11.7	12.1	220	3.4	124	2.2	8000
YC090	85	6.8	12.4	NC090	94	11.2	13.0	---	N/A	N/A	N/A	N/A	3000
YC090	85	6.8	12.4	NC120	99	11.9	13.0	---	N/A	N/A	N/A	N/A	3000
YC120	110	9.3	11.9	NC120	124	11.4	12.5	12.9	N/A	N/A	N/A	N/A	4000
YD120	108	9.1	11.8	ND120	124	11.2	11.2	11.6	N/A	N/A	N/A	N/A	4000
YC150	133	11.6	11.5	NC180	150	11.0	13.3	13.8	N/A	N/A	N/A	N/A	5000
YD150	136	11.5	11.8	ND180	150	11.0	12.1	12.3	N/A	N/A	N/A	N/A	5000
YC180	160	13.4	12.0	NC180	181	11.2	12.2	12.5	N/A	N/A	N/A	N/A	6000
YC180	160	13.4	12.0	NC240	190	11.7	12.7	12.5	N/A	N/A	N/A	N/A	6000
YD180	166	12.3	13.4	ND180	181	11.2	11.6	12.4	N/A	N/A	N/A	N/A	6000
YD180	166	12.3	13.4	(2)NC090	187	11.2	--	--	N/A	N/A	N/A	N/A	6000
YD180	166	12.3	13.4	(2)NC120	187	11.2	--	--	N/A	N/A	N/A	N/A	6000
YD180	166	12.3	13.4	ND240	190	11.7	13.4	11.2	N/A	N/A	N/A	N/A	6000
YC240	233	17.5	13.2	NC240	242	11.3	13.6	13.1	N/A	N/A	N/A	N/A	8000
YD240	222	17.3	12.8	ND240	242	11.3	11.9	12.6	N/A	N/A	N/A	N/A	8000
YD240	222	17.3	12.8	(2)NC120	240	11.6	--	--	N/A	N/A	N/A	N/A	8000

<sup>1</sup> Certified in accordance with the Unitary Large Equipment certification program, which is based on ARI Standard 340/360.

<sup>2</sup> Condensing unit only ratings are at 45°F SST and 95°F entering-air temperature.

<sup>3</sup> Gross capacity does not include heat added by blower motor. Refer to appropriate table for blower horsepower.

<sup>4</sup> Heat Pumps designed for matched systems only.

#### LEGEND

EER = Energy Efficiency Ratio

ARI = Air Conditioning and Refrigeration Institute

IPLV = Integration Part-Load Value

IEER = Integrated Energy Efficiency Ratio

### Heat Pump and Air Handling Cooling Capacities

#### PC090/NC090 Cooling Capacities

Air on Evaporator Coil		Temperature of Air on Condenser Coil															
CFM	WB (°F)	Total Capacity <sup>1</sup> (MBh)	Total Input (kW) <sup>2</sup>	Sensible Capacity (MBh)						Total Capacity <sup>1</sup> (MBh)	Total Input (kW) <sup>2</sup>	Sensible Capacity (MBh)					
				Return Dry Bulb (°F)								Return Dry Bulb (°F)					
				90	85	80	75	70	65			90	85	80	75	70	65
				<b>75°F</b>						<b>85°F</b>							
2250	77	112.8	5.9	54.5	44.9	35.3	-	-	-	107.0	6.5	51.9	42.4	32.9	-	-	-
	72	104.8	5.8	68.7	59.1	49.5	40.0	-	-	99.3	6.4	66.3	56.8	47.3	37.9	-	-
	67	96.7	5.7	82.9	73.4	63.8	54.2	44.6	-	91.7	6.3	80.8	71.3	61.8	52.3	42.8	-
	62	89.0	5.5	89.0	89.0	80.5	70.9	61.3	51.7	84.4	6.2	84.4	84.4	76.5	67.0	57.5	48.0
	57	88.9	5.6	88.9	88.9	80.5	70.9	61.4	51.8	84.6	6.2	84.6	84.6	75.7	66.2	56.8	47.3
2625	77	117.0	5.9	58.7	48.7	37.9	-	-	-	110.7	6.6	57.0	46.2	35.5	-	-	-
	72	108.6	5.8	74.8	64.0	53.2	42.5	-	-	102.7	6.5	72.5	61.8	51.1	40.4	-	-
	67	100.3	5.7	90.9	79.3	68.5	57.8	47.0	-	94.8	6.3	88.1	77.4	66.7	56.0	45.3	-
	62	92.3	5.6	92.3	92.3	86.5	76.2	64.9	54.1	87.3	6.2	87.3	87.3	82.6	71.9	61.1	50.4
	57	92.2	5.6	92.2	92.2	86.6	76.3	65.0	54.2	87.5	6.2	87.5	87.5	81.7	71.0	60.3	49.6
3000	77	121.1	5.9	63.0	52.6	40.6	-	-	-	114.3	6.6	62.0	50.1	38.1	-	-	-
	72	112.5	5.8	80.9	68.9	56.9	45.0	-	-	106.1	6.5	78.7	66.8	54.9	42.9	-	-
	67	103.8	5.7	98.9	85.3	73.3	61.3	49.3	-	97.9	6.4	95.4	83.5	71.6	59.6	47.7	-
	62	95.6	5.6	95.6	95.6	92.5	81.5	68.6	56.6	90.2	6.3	90.2	90.2	88.6	76.7	64.8	52.8
	57	95.4	5.6	95.4	95.4	92.6	81.7	68.6	56.6	90.4	6.2	90.4	90.4	87.7	75.8	63.9	51.9
3375	72	114.6	5.8	88.6	75.6	62.6	49.6	-	-	108.6	6.5	85.9	73.0	60.0	47.1	-	-
	67	105.7	5.7	103.3	93.6	80.6	67.6	54.6	-	100.3	6.4	99.0	91.3	78.3	65.4	52.4	-
	62	97.4	5.6	97.4	97.4	95.8	83.3	69.8	56.8	92.3	6.3	92.3	92.3	91.6	78.6	65.7	52.7
	57	97.2	5.6	97.2	97.2	95.8	83.3	69.7	56.7	92.5	6.3	92.5	92.5	91.2	78.3	65.3	52.3
3750	72	116.6	5.8	96.3	82.3	68.3	54.2	-	-	111.2	6.5	93.1	79.2	65.2	51.2	-	-
	67	107.7	5.7	107.7	101.9	87.9	73.8	59.8	-	102.6	6.4	102.6	99.0	85.1	71.1	57.1	-
	62	99.1	5.6	99.1	99.1	99.1	85.1	71.0	57.0	94.5	6.3	94.5	94.5	94.5	80.5	66.5	52.6
	57	99.0	5.6	99.0	99.0	99.0	84.9	70.9	56.8	94.7	6.3	94.7	94.7	94.7	80.7	66.7	52.8
				<b>95°F</b>						<b>105°F</b>							
2250	77	101.2	7.2	49.3	39.9	30.6	-	-	-	100.5	8.0	59.5	50.1	40.7	-	-	-
	72	93.9	7.1	63.9	54.6	45.2	35.8	-	-	90.2	7.9	67.7	58.3	48.9	39.4	-	-
	67	86.6	7.0	78.6	69.2	59.8	50.4	41.0	-	79.9	7.8	75.8	66.4	57.0	47.6	38.2	-
	62	79.8	6.9	79.8	79.8	72.5	63.1	53.7	44.4	74.8	7.7	74.8	74.8	67.3	57.9	48.5	39.0
	57	80.3	6.8	80.3	80.3	70.9	61.5	52.1	42.8	74.9	7.7	74.9	74.9	65.7	56.2	46.8	37.4
2625	77	104.3	7.3	55.2	43.8	33.1	-	-	-	103.7	8.0	68.8	55.1	44.4	-	-	-
	72	96.8	7.1	70.2	59.6	49.0	38.3	-	-	93.0	8.0	74.6	63.9	53.3	42.6	-	-
	67	89.3	7.0	85.3	75.4	64.8	54.2	43.5	-	82.4	7.9	80.4	72.8	62.1	51.4	40.8	-
	62	82.3	6.9	82.3	82.3	78.6	67.5	57.4	46.7	77.2	7.7	77.2	77.2	73.3	62.4	52.0	41.3
	57	82.8	6.9	82.8	82.8	76.9	65.7	55.6	45.0	77.2	7.7	77.2	77.2	71.5	60.6	50.2	39.5
3000	77	107.5	7.3	61.0	47.6	35.7	-	-	-	106.8	8.1	78.1	60.0	48.1	-	-	-
	72	99.7	7.2	76.5	64.6	52.8	40.9	-	-	95.9	8.0	81.5	69.6	57.7	45.8	-	-
	67	92.0	7.0	92.0	81.7	69.8	57.9	46.1	-	84.9	7.9	84.9	79.1	67.2	55.3	43.4	-
	62	84.7	6.9	84.7	84.7	84.7	71.9	61.0	49.1	79.6	7.8	79.6	79.6	79.3	66.9	55.5	43.6
	57	85.3	6.9	85.3	85.3	82.9	69.9	59.1	47.2	79.6	7.7	79.6	79.6	77.4	64.9	53.6	41.6
3375	72	102.7	7.2	83.2	70.3	57.4	44.6	-	-	98.8	8.0	87.6	76.1	63.2	50.2	-	-
	67	94.8	7.1	94.8	88.9	76.0	63.1	50.2	-	87.5	7.9	87.5	84.2	73.6	60.6	47.7	-
	62	87.3	6.9	87.3	87.3	87.3	73.9	61.5	48.6	82.0	7.8	82.0	82.0	81.8	68.6	55.9	43.0
	57	87.8	6.9	87.8	87.8	86.6	73.2	60.8	48.0	82.0	7.8	82.0	82.0	80.9	67.7	55.0	42.1
3750	72	105.7	7.2	89.9	76.0	62.1	48.2	-	-	101.7	8.0	93.8	82.7	68.7	54.7	-	-
	67	97.5	7.1	97.5	96.1	82.2	68.3	54.4	-	90.1	7.9	90.1	89.4	79.9	65.9	52.0	-
	62	89.8	7.0	89.8	89.8	89.8	75.9	62.0	48.1	84.4	7.8	84.4	84.4	84.4	70.4	56.4	42.4
	57	90.4	6.9	90.4	90.4	90.4	76.5	62.6	48.7	84.4	7.8	84.4	84.4	84.4	70.5	56.5	42.5

**PC090/NC090 Cooling Capacities (Continued)**

Air on Evaporator Coil		Temperature of Air on Condenser Coil																	
CFM	WB (°F)	Total Capacity <sup>1</sup> (MBh)	Total Input (kW) <sup>2</sup>	Sensible Capacity (MBh)						Total Capacity <sup>1</sup> (MBh)	Total Input (kW) <sup>2</sup>	Sensible Capacity (MBh)							
				Return Dry Bulb (°F)								Return Dry Bulb (°F)							
				90	85	80	75	70	65			90	85	80	75	70	65		
				<b>115°F</b>										<b>125°F</b>					
2250	77	99.8	8.8	69.7	60.3	50.9	-	-	-	99.1	9.6	79.9	70.5	61.0	-	-	-		
	72	86.5	8.7	71.4	62.0	52.6	43.1	-	-	82.7	9.5	75.2	65.7	56.3	46.8	-	-		
	67	73.1	8.7	73.1	63.7	54.2	44.8	35.4	-	66.4	9.5	66.4	60.9	51.5	42.0	32.6	-		
	62	69.9	8.5	69.9	69.9	62.0	52.6	43.2	33.7	64.9	9.4	64.9	64.9	56.8	47.3	37.9	28.4		
	57	69.5	8.5	69.5	69.5	60.4	50.9	41.5	32.1	64.1	9.4	64.1	64.1	55.1	45.6	36.2	26.7		
2625	77	103.0	8.8	82.4	66.4	55.7	-	-	-	102.3	9.6	92.7	77.7	67.0	-	-	-		
	72	89.2	8.8	78.9	68.2	57.6	46.9	-	-	85.4	9.6	83.3	72.6	61.9	51.2	-	-		
	67	75.5	8.7	75.5	70.1	59.4	48.7	38.0	-	68.5	9.6	68.5	67.4	56.7	46.0	35.3	-		
	62	72.1	8.6	72.1	72.1	67.9	57.3	46.6	35.9	67.0	9.4	67.0	67.0	62.6	52.1	41.2	30.5		
	57	71.7	8.6	71.7	71.7	66.1	55.4	44.8	34.1	66.2	9.4	66.2	66.2	60.7	50.3	39.3	28.6		
3000	77	106.2	8.9	95.1	72.5	60.5	-	-	-	105.6	9.7	105.6	84.9	73.0	-	-	-		
	72	92.0	8.8	86.4	74.5	62.6	50.6	-	-	88.1	9.6	88.1	79.4	67.5	55.5	-	-		
	67	77.8	8.7	77.8	76.5	64.6	52.6	40.7	-	70.7	9.6	70.7	70.7	62.0	50.0	38.0	-		
	62	74.4	8.6	74.4	74.4	73.8	61.9	50.0	38.0	69.2	9.5	69.2	69.2	68.4	56.9	44.5	32.5		
	57	73.9	8.6	73.9	73.9	71.9	59.9	48.0	36.1	68.3	9.5	68.3	68.3	66.4	54.9	42.4	30.5		
3375	72	94.8	8.8	92.1	81.9	68.9	55.9	-	-	90.9	9.7	90.9	87.7	74.6	61.5	-	-		
	67	80.2	8.8	80.2	79.6	71.1	58.1	45.1	-	72.9	9.6	72.9	72.9	68.7	55.6	42.5	-		
	62	76.7	8.6	76.7	76.7	76.4	63.4	50.4	37.4	71.3	9.5	71.3	71.3	71.0	58.1	44.8	31.7		
	57	76.2	8.6	76.2	76.2	75.2	62.2	49.2	36.2	70.4	9.5	70.4	70.4	69.5	56.7	43.3	30.3		
3750	72	97.7	8.8	97.7	89.3	75.2	61.1	-	-	93.7	9.7	93.7	93.7	81.8	67.6	-	-		
	67	82.6	8.8	82.6	82.6	77.7	63.6	49.5	-	75.2	9.6	75.2	75.2	75.2	61.2	47.0	-		
	62	79.0	8.7	79.0	79.0	79.0	64.9	50.8	36.7	73.5	9.5	73.5	73.5	73.5	59.3	45.2	31.0		
	57	78.5	8.6	78.5	78.5	78.5	64.4	50.3	36.3	72.6	9.5	72.6	72.6	72.6	58.4	44.2	30.0		

<sup>1</sup> These capacities are gross ratings. For net capacity, deduct supply air blower motor, MBh. Example: Refer to the appropriate Blower Performance Table for the BHP of the supply air blower motor, MBh = 3.415 x kW and kW = BHP x 0.746 ÷ nameplate rated motor efficiency.

<sup>2</sup> These ratings include the condenser fan motors and the compressor motors but not the supply air blower motor.

**PC120/NC120**

Air on Evaporator Coil		Temperature of Air on Condenser Coil															
CFM	WB (°F)	Total Capacity <sup>1</sup> (MBh)	Total Input (kW) <sup>2</sup>	Sensible Capacity (MBh)						Total Capacity <sup>1</sup> (MBh)	Total Input (kW) <sup>2</sup>	Sensible Capacity (MBh)					
				Return Dry Bulb (°F)								Return Dry Bulb (°F)					
				90	85	80	75	70	65			90	85	80	75	70	65
		<b>75°F</b>								<b>85°F</b>							
3000	77	140.5	7.5	70.2	58.2	46.2	-	-	-	134.2	8.6	65.0	52.8	40.6	-	-	-
	72	133.6	7.5	87.5	75.5	63.5	51.5	-	-	127.3	8.5	84.4	72.2	59.9	47.7	-	-
	67	126.6	7.4	104.8	92.8	80.8	68.9	56.9	-	120.3	8.5	103.8	91.5	79.3	67.1	54.8	-
	62	120.2	7.4	120.2	120.2	107.7	95.7	83.8	71.8	113.2	8.4	113.2	113.2	101.2	88.9	76.7	64.5
	57	121.8	7.3	121.8	123.0	114.5	102.5	90.5	78.6	117.1	8.4	117.1	117.1	106.6	94.4	82.2	69.9
3500	77	147.3	7.7	74.8	62.4	49.1	-	-	-	140.4	8.7	71.4	57.6	43.7	-	-	-
	72	140.0	7.6	93.9	80.6	67.3	54.1	-	-	133.2	8.7	92.3	78.4	64.6	50.7	-	-
	67	132.8	7.6	112.9	98.8	85.5	72.3	59.0	-	125.9	8.6	113.2	99.3	85.5	71.6	57.8	-
	62	126.0	7.6	126.0	126.0	114.2	101.0	87.6	74.4	118.5	8.5	118.5	118.5	109.0	95.2	81.3	67.5
	57	127.7	7.5	127.7	128.3	121.4	108.7	94.9	81.6	122.5	8.5	122.5	122.5	114.9	101.1	87.2	73.4
4000	77	154.1	7.8	79.4	66.6	52.0	-	-	-	146.6	8.9	77.8	62.3	46.9	-	-	-
	72	146.5	7.8	100.2	85.7	71.1	56.6	-	-	139.0	8.8	100.2	84.7	69.2	53.8	-	-
	67	138.9	7.8	121.1	104.8	90.2	75.7	61.1	-	131.5	8.7	122.5	107.1	91.6	76.2	60.7	-
	62	131.8	7.8	131.8	131.8	120.6	106.3	91.5	76.9	123.7	8.7	123.7	123.7	116.9	101.4	86.0	70.5
	57	133.6	7.6	133.6	133.6	128.3	114.8	99.2	84.6	127.9	8.6	127.9	127.9	123.2	107.7	92.3	76.8
4500	72	148.2	7.7	110.0	94.1	78.1	62.2	-	-	140.9	8.7	108.1	91.5	74.8	58.1	-	-
	67	140.5	7.7	131.6	115.2	99.3	83.4	67.5	-	133.2	8.6	128.7	115.6	99.0	82.3	65.6	-
	62	133.4	7.7	133.4	133.4	127.8	112.0	95.9	80.0	125.3	8.6	125.3	125.3	121.9	105.3	88.6	71.9
	57	135.2	7.5	135.2	135.2	132.5	117.2	100.7	84.8	129.6	8.6	129.6	129.6	127.2	110.6	93.9	77.2
	5000	72	150.0	7.6	119.7	102.4	85.1	67.9	-	-	142.7	8.6	116.1	98.2	80.3	62.5	-
67		142.2	7.5	142.2	125.6	108.3	91.1	73.8	-	134.9	8.5	134.9	124.2	106.3	88.4	70.5	-
62		134.9	7.5	134.9	134.9	134.9	117.6	100.4	83.1	127.0	8.5	127.0	127.0	127.0	109.1	91.2	73.3
57		136.7	7.4	136.7	136.7	136.7	119.5	102.2	84.9	131.3	8.5	131.3	131.3	131.3	113.4	95.5	77.6
		<b>95°F</b>								<b>105°F</b>							
3000	77	128.0	9.7	59.9	47.4	34.9	-	-	-	120.6	10.9	59.2	46.6	34.0	-	-	-
	72	121.0	9.6	81.3	68.8	56.3	43.8	-	-	113.1	10.8	79.6	67.0	54.4	41.8	-	-
	67	114.1	9.5	102.8	90.3	77.8	65.3	52.8	-	105.6	10.7	100.0	87.4	74.7	62.1	49.5	-
	62	106.3	9.3	106.3	106.3	94.7	82.2	69.7	57.2	101.1	10.6	101.1	101.1	90.6	78.0	65.4	52.8
	57	112.4	9.5	112.4	111.3	98.8	86.3	73.8	61.3	104.8	10.7	104.8	104.2	92.7	80.1	67.5	54.9
3500	77	133.6	9.8	68.0	52.7	38.3	-	-	-	126.1	11.0	69.7	51.8	37.3	-	-	-
	72	126.3	9.7	90.7	76.3	61.9	47.4	-	-	118.3	10.9	88.6	74.1	59.6	45.1	-	-
	67	119.0	9.6	113.4	99.8	85.4	71.0	56.5	-	110.4	10.8	107.6	96.5	82.0	67.5	53.0	-
	62	111.0	9.4	111.0	111.0	103.9	89.4	75.1	60.6	105.7	10.7	105.7	105.7	99.3	84.8	70.3	55.8
	57	117.3	9.6	117.3	116.7	108.4	93.4	79.6	65.1	109.5	10.8	109.5	109.3	101.6	86.9	72.6	58.1
4000	77	139.1	9.9	76.2	58.1	41.7	-	-	-	131.6	11.1	80.1	56.9	40.5	-	-	-
	72	131.6	9.8	100.1	83.7	67.4	51.0	-	-	123.4	11.0	97.7	81.3	64.9	48.5	-	-
	67	124.0	9.7	124.0	109.4	93.0	76.6	60.3	-	115.2	10.9	115.2	105.6	89.2	72.8	56.4	-
	62	115.6	9.5	115.6	115.6	113.2	96.5	80.5	64.1	110.3	10.8	110.3	110.3	108.1	91.6	75.3	58.9
	57	122.2	9.7	122.2	122.2	118.1	100.6	85.4	69.0	114.3	10.9	114.3	114.3	110.6	93.6	77.8	61.4
4500	72	133.5	9.7	106.3	88.9	71.5	54.0	-	-	124.9	10.9	104.6	86.9	69.3	51.7	-	-
	67	125.8	9.6	125.8	116.1	98.6	81.2	63.8	-	116.6	10.8	116.6	110.6	95.3	77.7	60.1	-
	62	117.3	9.5	117.3	117.3	116.1	98.5	81.2	63.8	111.6	10.7	111.6	111.6	110.5	92.8	75.3	57.6
	57	124.0	9.6	124.0	124.0	122.0	104.0	87.1	69.7	115.7	10.8	115.7	115.7	113.8	95.9	78.6	61.0
	5000	72	135.4	9.6	112.5	94.0	75.5	57.0	-	-	126.3	10.9	111.5	92.6	73.8	55.0	-
67		127.6	9.5	127.6	122.8	104.3	85.8	67.3	-	118.0	10.8	118.0	115.5	101.5	82.6	63.8	-
62		119.0	9.4	119.0	119.0	119.0	100.5	82.0	63.5	112.9	10.7	112.9	112.9	112.9	94.1	75.2	56.4
57		125.8	9.5	125.8	125.8	125.8	107.3	88.8	70.3	117.0	10.7	117.0	117.0	117.0	98.2	79.4	60.5

## PC120/NC120 (Continued)

Air on Evaporator Coil		Temperature of Air on Condenser Coil															
CFM	WB (°F)	Total Capacity <sup>1</sup> (MBh)	Total Input (kW) <sup>2</sup>	Sensible Capacity (MBh)						Total Capacity <sup>1</sup> (MBh)	Total Input (kW) <sup>2</sup>	Sensible Capacity (MBh)					
				Return Dry Bulb (°F)								Return Dry Bulb (°F)					
				90	85	80	75	70	65			90	85	80	75	70	65
		<b>115°F</b>						<b>125°F</b>									
3000	77	113.3	12.1	58.5	45.8	33.1	-	-	-	105.9	13.2	57.8	45.0	32.1	-	-	-
	72	105.2	12.0	77.8	65.1	52.4	39.7	-	-	97.3	13.2	76.1	63.2	50.4	37.6	-	-
	67	97.2	11.9	97.2	84.4	71.7	59.0	46.3	-	88.7	13.1	88.7	81.5	68.7	55.8	43.0	-
	62	95.9	11.8	95.9	95.9	86.5	73.8	61.1	48.4	90.6	13.1	90.6	90.6	82.5	69.6	56.8	43.9
	57	97.1	11.8	97.1	97.1	86.6	73.9	61.2	48.4	89.5	13.0	89.5	89.5	80.5	67.7	54.8	42.0
3500	77	118.7	12.2	71.3	50.8	36.2	-	-	-	111.3	13.4	72.9	49.8	35.2	-	-	-
	72	110.2	12.1	86.5	72.0	57.4	42.8	-	-	102.2	13.3	84.4	69.8	55.1	40.5	-	-
	67	101.8	12.0	101.8	93.1	78.5	64.0	49.4	-	93.2	13.2	93.2	89.8	75.1	60.4	45.8	-
	62	100.4	11.9	100.4	100.4	94.8	80.2	65.6	51.0	95.2	13.2	95.2	95.2	90.2	75.6	60.9	46.2
	57	101.8	12.0	101.8	101.8	94.8	80.3	65.7	51.1	94.0	13.2	94.0	94.0	88.1	73.7	58.8	44.1
4000	77	124.1	12.3	84.0	55.8	39.4	-	-	-	116.6	13.5	88.0	54.6	38.2	-	-	-
	72	115.3	12.2	95.2	78.8	62.4	45.9	-	-	107.1	13.4	92.8	76.3	59.9	43.4	-	-
	67	106.4	12.1	106.4	101.8	85.4	68.9	52.5	-	97.7	13.3	97.7	97.7	81.5	65.1	48.6	-
	62	105.0	12.1	105.0	105.0	103.0	86.6	70.1	53.7	99.7	13.3	99.7	99.7	97.9	81.6	65.0	48.5
	57	106.4	12.1	106.4	106.4	103.1	86.7	70.2	53.8	98.5	13.3	98.5	98.5	95.6	79.7	62.7	46.2
4500	72	116.3	12.1	102.8	85.0	67.2	49.4	-	-	107.6	13.3	101.0	83.1	65.1	47.1	-	-
	67	107.3	12.0	107.3	105.0	92.0	74.2	56.4	-	98.1	13.3	98.1	98.1	88.7	70.7	52.7	-
	62	105.9	12.0	105.9	105.9	104.9	87.1	69.3	51.5	100.2	13.2	100.2	100.2	99.3	81.4	63.3	45.4
	57	107.3	12.0	107.3	107.3	105.7	87.9	70.1	52.3	98.9	13.2	98.9	98.9	97.5	79.8	61.5	43.6
5000	72	117.2	12.1	110.4	91.2	72.0	52.9	-	-	108.1	13.3	108.1	89.8	70.3	50.8	-	-
	67	108.3	12.0	108.3	108.3	98.6	79.5	60.3	-	98.6	13.2	98.6	98.6	95.8	76.3	56.8	-
	62	106.8	11.9	106.8	106.8	106.8	87.6	68.5	49.3	100.7	13.2	100.7	100.7	100.7	81.2	61.7	42.2
	57	108.2	11.9	108.2	108.2	108.2	89.0	69.9	50.7	99.4	13.1	99.4	99.4	99.4	79.9	60.4	40.9

<sup>1</sup> These capacities are gross ratings. For net capacity, deduct supply air blower motor, MBh. Example: Refer to the appropriate Blower Performance Table for the BHP of the supply air blower motor, MBh = 3.415 x kW and kW = BHP x 0.746 ÷ nameplate rated motor efficiency.

<sup>2</sup> These ratings include the condenser fan motors and the compressor motors but not the supply air blower motor.

**PC180/NC180**

Air on Evaporator Coil		Temperature of Air on Condenser Coil																
CFM	WB (°F)	Total Capacity <sup>1</sup> (MBh)	Total Input (kW) <sup>2</sup>	Sensible Capacity (MBh)						Total Capacity <sup>1</sup> (MBh)	Total Input (kW) <sup>2</sup>	Sensible Capacity (MBh)						
				Return Dry Bulb (°F)								Return Dry Bulb (°F)						
				90	85	80	75	70	65			90	85	80	75	70	65	
		<b>75°F</b>								<b>85°F</b>								
4500	77	223.0	12.5	104.1	85.2	66.4	-	-	-	216.7	13.8	104.7	85.9	67.0	-	-	-	
	72	209.3	12.3	134.7	115.8	97.0	78.1	-	-	200.9	13.6	133.0	114.1	95.2	76.3	-	-	
	67	195.7	12.1	165.2	146.4	127.6	108.7	89.9	-	185.0	13.4	161.2	142.3	123.4	104.5	85.7	-	
	62	176.7	11.8	176.7	176.7	152.0	133.2	114.3	95.5	169.4	13.0	169.4	169.4	151.2	132.4	113.5	94.6	
	57	179.6	11.8	179.6	179.6	159.1	140.3	121.4	102.6	173.1	13.1	173.1	173.1	154.4	135.5	116.7	97.8	
5250	77	229.0	12.6	113.8	93.3	71.8	-	-	-	221.4	13.9	114.8	93.3	71.7	-	-	-	
	72	215.0	12.4	147.9	126.3	104.8	83.3	-	-	205.2	13.6	145.0	123.5	101.9	80.3	-	-	
	67	200.9	12.2	181.9	159.4	137.8	116.3	94.8	-	189.1	13.4	175.2	153.7	132.1	110.5	88.9	-	
	62	181.4	11.8	181.4	181.4	164.3	143.6	121.3	99.8	173.0	13.1	173.0	173.0	161.9	140.3	118.7	97.1	
	57	184.5	11.9	184.5	184.5	171.9	151.4	128.9	107.4	176.9	13.1	176.9	176.9	165.3	143.7	122.1	100.6	
6000	77	235.0	12.6	123.5	101.4	77.2	-	-	-	226.1	13.9	124.9	100.6	76.4	-	-	-	
	72	220.6	12.4	161.0	136.9	112.7	88.5	-	-	209.6	13.7	157.1	132.8	108.6	84.3	-	-	
	67	206.2	12.2	198.5	172.3	148.1	123.9	99.8	-	193.1	13.4	189.3	165.0	140.8	116.5	92.2	-	
	62	186.2	11.9	186.2	186.2	176.7	154.1	128.3	104.1	176.7	13.1	176.7	176.7	172.5	148.2	124.0	99.7	
	57	189.3	11.9	189.3	189.3	184.8	162.6	136.4	112.2	180.6	13.2	180.6	180.6	176.1	151.8	127.6	103.3	
6750	72	223.2	12.5	170.5	144.3	118.1	91.9	-	-	213.0	13.7	168.5	142.1	115.7	89.3	-	-	
	67	208.6	12.3	204.8	181.5	155.3	129.1	102.9	-	196.2	13.5	194.3	176.4	150.0	123.6	97.3	-	
	62	188.4	11.9	188.4	188.4	183.6	158.3	131.3	105.1	179.6	13.2	179.6	179.6	177.5	151.1	124.7	98.3	
	57	191.6	12.0	191.6	191.6	189.3	164.1	136.9	110.7	183.6	13.2	183.6	183.6	181.3	154.9	128.5	102.2	
	72	225.9	12.6	179.9	151.7	123.5	95.3	-	-	216.4	13.8	179.9	151.4	122.9	94.4	-	-	
7500	67	211.1	12.4	211.1	190.7	162.5	134.3	106.1	-	199.4	13.5	199.4	187.8	159.3	130.8	102.3	-	
	62	190.6	12.0	190.6	190.6	190.6	162.4	134.2	106.0	182.5	13.2	182.5	182.5	182.5	154.0	125.5	97.0	
	57	193.8	12.1	193.8	193.8	183.8	165.6	137.4	109.2	186.5	13.3	186.5	186.5	186.5	158.0	129.5	101.0	
			<b>95°F</b>								<b>105°F</b>							
	4500	77	210.5	15.1	105.4	86.5	67.6	-	-	-	192.8	16.7	98.9	80.0	61.1	-	-	-
72		192.4	14.9	131.3	112.4	93.4	74.5	-	-	177.2	16.5	125.6	106.7	87.8	68.9	-	-	
67		174.4	14.6	157.1	138.2	119.3	100.4	81.4	-	161.6	16.3	152.4	133.5	114.6	95.7	76.8	-	
62		162.0	14.3	162.0	162.0	150.5	131.6	112.6	93.7	150.1	16.0	150.1	150.1	142.4	123.5	104.6	85.7	
57		166.6	14.4	166.6	166.6	149.8	130.8	111.9	93.0	155.1	16.1	155.1	155.1	137.9	119.0	100.1	81.2	
5250	77	213.8	15.2	115.9	93.2	71.6	-	-	-	196.5	16.7	114.1	86.9	65.3	-	-	-	
	72	195.5	14.9	142.2	120.6	99.0	77.3	-	-	180.6	16.5	137.1	115.5	93.8	72.2	-	-	
	67	177.2	14.6	168.6	148.0	126.3	104.7	83.1	-	164.7	16.3	160.1	144.1	122.4	100.8	79.2	-	
	62	164.7	14.4	164.7	164.7	159.4	136.9	116.1	94.5	153.0	16.1	153.0	153.0	152.2	130.1	108.9	87.3	
	57	169.2	14.4	169.2	169.2	158.6	136.0	115.3	93.7	158.1	16.1	158.1	158.1	147.3	125.2	104.1	82.4	
6000	77	217.2	15.2	126.3	99.9	75.6	-	-	-	200.2	16.8	129.3	93.8	69.4	-	-	-	
	72	198.6	14.9	153.1	128.8	104.5	80.1	-	-	184.1	16.5	148.6	124.2	99.9	75.5	-	-	
	67	180.0	14.6	180.0	157.7	133.4	109.0	84.7	-	167.9	16.3	167.9	154.7	130.3	106.0	81.6	-	
	62	167.3	14.4	167.3	167.3	168.3	142.3	119.6	95.3	155.9	16.1	155.9	155.9	162.0	136.8	113.2	88.9	
	57	171.9	14.4	171.9	171.9	167.5	141.1	118.8	94.5	161.1	16.1	161.1	161.1	156.7	131.4	108.0	83.7	
6750	72	202.8	15.0	166.5	139.9	113.4	86.8	-	-	187.4	16.6	160.8	134.3	107.7	81.1	-	-	
	67	183.8	14.7	183.8	171.3	144.7	118.2	91.6	-	170.9	16.4	170.9	163.6	140.5	113.9	87.3	-	
	62	170.8	14.4	170.8	170.8	171.3	143.9	118.2	91.6	158.7	16.1	158.7	158.7	161.7	134.7	108.6	82.0	
	57	175.6	14.5	175.6	175.6	173.3	145.8	120.2	93.6	164.0	16.2	164.0	164.0	161.8	134.7	108.6	82.1	
	72	207.0	15.0	179.8	151.0	122.2	93.5	-	-	190.7	16.6	173.1	144.3	115.5	86.7	-	-	
7500	67	187.6	14.7	187.6	184.9	156.1	127.3	98.5	-	173.9	16.4	173.9	172.5	150.7	121.9	93.1	-	
	62	174.3	14.4	174.3	174.3	174.3	145.5	116.7	87.9	161.5	16.2	161.5	161.5	161.5	132.7	103.9	75.1	
	57	179.2	14.5	179.2	179.2	179.2	150.4	121.6	92.8	166.8	16.2	166.8	166.8	166.8	138.1	109.3	80.5	



## PC180/NC180 (Continued)

Air on Evaporator Coil		Temperature of Air on Condenser Coil																	
CFM	WB (°F)	Total Capacity <sup>1</sup> (MBh)	Total Input (kW) <sup>2</sup>	Sensible Capacity (MBh)						Total Capacity <sup>1</sup> (MBh)	Total Input (kW) <sup>2</sup>	Sensible Capacity (MBh)							
				Return Dry Bulb (°F)								Return Dry Bulb (°F)							
				90	85	80	75	70	65			90	85	80	75	70	65		
		115°F									125°F								
4500	77	175.1	18.3	92.4	73.5	54.6	-	-	-	157.4	19.9	85.8	67.0	48.1	-	-	-		
	72	162.0	18.1	120.0	101.1	82.2	63.3	-	-	146.7	19.8	114.3	95.5	76.6	57.8	-	-		
	67	148.8	18.0	147.6	128.7	109.8	91.0	72.1	-	136.1	19.6	136.1	124.0	105.1	86.3	67.4	-		
	62	138.1	17.8	138.1	138.1	134.4	115.5	96.6	77.7	126.2	19.5	126.2	126.2	126.2	107.5	88.6	69.7		
	57	143.6	17.8	143.6	143.6	126.1	107.2	88.3	69.4	132.1	19.6	132.1	132.1	114.2	95.4	76.5	57.6		
5250	77	179.2	18.3	112.3	80.6	58.9	-	-	-	161.8	19.9	110.6	74.3	52.6	-	-	-		
	72	165.7	18.1	132.0	110.4	88.7	67.1	-	-	150.8	19.8	126.9	105.3	83.6	62.0	-	-		
	67	152.3	18.0	151.7	140.2	118.6	96.9	75.3	-	139.9	19.6	139.9	136.3	114.7	93.0	71.4	-		
	62	141.3	17.8	141.3	141.3	145.0	123.4	101.7	80.1	129.7	19.5	129.7	129.7	129.7	116.6	94.6	72.9		
	57	146.9	17.8	146.9	146.9	136.1	114.4	92.8	71.1	135.7	19.6	135.7	135.7	124.8	103.6	81.5	59.9		
6000	77	183.2	18.3	132.3	87.6	63.3	-	-	-	166.2	19.9	135.3	81.5	57.1	-	-	-		
	72	169.5	18.1	144.0	119.6	95.3	70.9	-	-	154.9	19.8	139.5	115.1	90.6	66.2	-	-		
	67	155.8	18.0	155.8	151.6	127.3	102.9	78.5	-	143.6	19.6	143.6	143.6	124.2	99.8	75.4	-		
	62	144.5	17.8	144.5	144.5	155.7	131.3	106.9	82.5	133.2	19.5	133.2	133.2	133.2	125.8	100.5	76.1		
	57	150.2	17.9	150.2	150.2	146.0	121.6	97.3	72.9	139.4	19.6	139.4	139.4	135.3	111.9	86.5	62.1		
6750	72	171.9	18.2	155.2	128.6	102.0	75.4	-	-	156.4	19.8	149.5	122.9	96.3	69.7	-	-		
	67	158.0	18.0	158.0	155.9	136.3	109.7	83.1	-	145.1	19.7	145.1	145.1	132.0	105.4	78.8	-		
	62	146.6	17.8	146.6	146.6	152.1	125.6	99.0	72.4	134.5	19.5	134.5	134.5	134.5	116.4	89.4	62.7		
	57	152.4	17.9	152.4	152.4	150.3	123.7	97.1	70.5	140.8	19.6	140.8	140.8	138.8	112.7	85.5	58.9		
	7500	72	174.3	18.2	166.3	137.5	108.8	80.0	-	-	158.0	19.9	158.0	130.8	102.0	73.2	-	-	
67		160.2	18.1	160.2	160.2	145.3	116.5	87.7	-	146.5	19.8	146.5	146.5	139.9	111.1	82.3	-		
62		148.6	17.9	148.6	148.6	148.6	119.8	91.0	62.3	135.8	19.6	135.8	135.8	135.8	107.0	78.2	49.4		
57		154.5	18.0	154.5	154.5	154.5	125.7	96.9	68.1	142.2	19.7	142.2	142.2	142.2	113.4	84.6	55.8		

<sup>1</sup> These capacities are gross ratings. For net capacity, deduct supply air blower motor, MBh. Example: Refer to the appropriate Blower Performance Table for the BHP of the supply air blower motor, MBh = 3.415 x kW and kW = BHP x 0.746 ÷ nameplate rated motor efficiency.

<sup>2</sup> These ratings include the condenser fan motors and the compressor motors but not the supply air blower motor

**PD180/ND180**

Air on Evaporator Coil		Temperature of Air on Condenser Coil																		
CFM	WB (°F)	Total Capacity <sup>1</sup> (MBh)	Total Input (kW) <sup>2</sup>	Sensible Capacity (MBh)						Total Capacity <sup>1</sup> (MBh)	Total Input (kW) <sup>2</sup>	Sensible Capacity (MBh)								
				Return Dry Bulb (°F)								Return Dry Bulb (°F)								
				90	85	80	75	70	65			90	85	80	75	70	65			
		<b>75°F</b>						<b>85°F</b>												
4500	77	231.4	12.4	111.6	93.0	74.5	-	-	-	219.9	13.7	106.4	87.9	69.5	-	-	-			
	72	215.6	12.0	142.9	124.4	105.8	87.2	-	-	204.0	13.4	138.2	119.7	101.2	82.8	-	-			
	67	199.7	11.7	174.3	155.7	137.2	118.6	100.0	-	188.1	13.1	169.9	151.4	133.0	114.5	96.0	-			
	62	183.7	11.4	183.7	183.7	170.7	152.1	133.6	115.0	174.3	12.8	174.3	174.3	163.8	145.3	126.9	108.4			
	57	184.6	11.4	184.6	184.6	173.2	154.6	136.1	117.5	175.3	12.8	175.3	175.3	164.8	146.3	127.8	109.4			
5250	77	233.6	12.4	117.3	98.2	76.9	-	-	-	222.0	13.7	114.1	92.9	71.7	-	-	-			
	72	217.6	12.1	151.9	130.6	109.3	88.0	-	-	206.0	13.4	146.9	125.7	104.5	83.3	-	-			
	67	201.6	11.7	186.5	163.0	141.7	120.4	99.1	-	189.9	13.1	179.7	158.5	137.2	116.0	94.8	-			
	62	185.5	11.4	185.5	185.5	176.3	155.6	133.7	112.4	176.0	12.8	176.0	176.0	169.1	147.9	126.6	105.4			
	57	186.3	11.4	186.3	186.3	178.9	158.5	136.3	115.0	177.0	12.8	177.0	177.0	170.1	148.8	127.6	106.4			
6000	77	235.8	12.4	123.1	103.4	79.4	-	-	-	224.2	13.7	121.8	97.9	73.9	-	-	-			
	72	219.7	12.1	160.9	136.9	112.8	88.7	-	-	208.0	13.4	155.6	131.7	107.7	83.8	-	-			
	67	203.5	11.7	198.8	170.3	146.2	122.2	98.1	-	191.8	13.1	189.4	165.5	141.5	117.6	93.6	-			
	62	187.2	11.4	187.2	187.2	182.0	159.2	133.8	109.8	177.7	12.9	177.7	177.7	174.3	150.4	126.4	102.5			
	57	188.0	11.4	188.0	188.0	184.6	162.4	136.5	112.4	178.7	12.9	178.7	178.7	175.4	151.4	127.5	103.5			
6750	72	222.5	12.1	171.1	144.6	118.1	91.7	-	-	210.6	13.5	165.7	139.4	113.2	86.9	-	-			
	67	206.2	11.8	203.8	179.6	153.2	126.7	100.2	-	194.2	13.2	193.0	174.9	148.6	122.4	96.1	-			
	62	189.7	11.5	189.7	189.7	187.0	161.2	134.1	107.6	180.0	12.9	180.0	180.0	178.3	152.0	125.7	99.5			
	57	190.5	11.5	190.5	190.5	188.8	163.3	135.9	109.4	181.0	12.9	181.0	181.0	179.3	153.1	126.8	100.5			
	72	225.4	12.2	181.3	152.4	123.5	94.6	-	-	213.3	13.6	175.8	147.2	118.6	90.0	-	-			
7500	67	208.9	11.8	208.9	189.0	160.1	131.2	102.3	-	196.7	13.2	196.7	184.4	155.8	127.2	98.6	-			
	62	192.1	11.5	192.1	192.1	192.1	163.2	134.3	105.5	182.2	13.0	182.2	182.2	182.2	153.6	125.0	96.4			
	57	193.0	11.5	193.0	193.0	193.0	164.1	135.2	106.3	183.3	13.0	183.3	183.3	183.3	154.7	126.1	97.5			
			<b>95°F</b>						<b>105°F</b>											
	4500	77	208.3	15.1	101.3	82.9	64.5	-	-	-	192.0	17.0	96.4	77.9	59.4	-	-	-		
72		192.4	14.8	133.4	115.0	96.6	78.3	-	-	177.3	16.7	128.6	110.2	91.7	73.2	-	-			
67		176.4	14.5	165.5	147.2	128.8	110.4	92.0	-	162.5	16.4	157.1	142.5	124.0	105.5	87.0	-			
62		164.9	14.3	164.9	164.9	156.9	138.5	120.2	101.8	153.2	16.2	153.2	153.2	149.2	130.7	112.3	93.8			
57		166.1	14.3	166.1	166.1	156.3	138.0	119.6	101.2	155.2	16.2	155.2	155.2	146.0	127.5	109.0	90.6			
5250	77	210.5	15.1	110.9	87.6	66.5	-	-	-	193.9	17.0	110.4	82.4	61.2	-	-	-			
	72	194.3	14.8	141.9	120.8	99.7	78.5	-	-	179.0	16.7	136.8	115.7	94.5	73.4	-	-			
	67	178.2	14.5	172.8	153.9	132.8	111.7	90.6	-	164.1	16.4	161.4	149.0	127.8	106.6	85.5	-			
	62	166.5	14.3	166.5	166.5	161.8	140.1	119.6	98.5	154.7	16.2	154.7	154.7	154.2	132.7	111.9	90.7			
	57	167.8	14.3	167.8	167.8	161.2	139.2	119.0	97.9	156.8	16.2	156.8	156.8	150.5	128.9	108.2	87.0			
6000	77	212.6	15.1	120.6	92.3	68.5	-	-	-	195.8	17.0	124.4	86.9	63.1	-	-	-			
	72	196.3	14.8	150.3	126.5	102.7	78.8	-	-	180.8	16.7	145.0	121.2	97.3	73.5	-	-			
	67	180.0	14.5	180.0	160.6	136.8	113.0	89.2	-	165.7	16.4	165.7	155.5	131.6	107.8	83.9	-			
	62	168.2	14.3	168.2	168.2	166.7	141.6	119.0	95.2	156.2	16.2	156.2	156.2	159.2	134.7	111.5	87.6			
	57	169.5	14.3	169.5	169.5	166.1	140.4	118.4	94.6	158.3	16.2	158.3	158.3	155.0	130.2	107.3	83.4			
6750	72	198.7	14.9	160.3	134.2	108.2	82.1	-	-	183.0	16.8	155.6	129.3	103.0	76.7	-	-			
	67	182.2	14.6	182.2	170.2	144.1	118.0	92.0	-	167.8	16.5	167.8	161.5	139.3	113.0	86.7	-			
	62	170.3	14.3	170.3	170.3	169.5	142.8	117.4	91.3	158.2	16.2	158.2	158.2	159.7	133.0	107.1	80.8			
	57	171.6	14.4	171.6	171.6	169.9	142.9	117.7	91.6	160.3	16.3	160.3	160.3	158.6	131.9	106.0	79.7			
	72	201.2	14.9	170.3	142.0	113.6	85.3	-	-	185.3	16.8	166.3	137.5	108.8	80.0	-	-			
7500	67	184.5	14.6	184.5	179.8	151.4	123.1	94.8	-	169.9	16.5	169.9	167.5	147.1	118.3	89.6	-			
	62	172.4	14.4	172.4	172.4	172.4	144.1	115.7	87.4	160.1	16.3	160.1	160.1	160.1	131.4	102.6	73.9			
	57	173.7	14.5	173.7	173.7	173.7	145.3	117.0	88.7	162.3	16.4	162.3	162.3	162.3	133.5	104.8	76.0			

## PD180/ND180 (Continued)

Air on Evaporator Coil		Temperature of Air on Condenser Coil																			
CFM	WB (°F)	Total Capacity <sup>1</sup> (MBh)	Total Input (kW) <sup>2</sup>	Sensible Capacity (MBh)						Total Capacity <sup>1</sup> (MBh)	Total Input (kW) <sup>2</sup>	Sensible Capacity (MBh)									
				Return Dry Bulb (°F)								Return Dry Bulb (°F)									
				90	85	80	75	70	65			90	85	80	75	70	65				
		115°F										125°F									
4500	77	175.7	18.9	91.5	72.9	54.3	-	-	-	159.4	20.8	86.6	67.9	49.2	-	-	-				
	72	162.2	18.6	123.9	105.3	86.8	68.2	-	-	147.1	20.5	119.1	100.5	81.8	63.1	-	-				
	67	148.6	18.2	148.6	137.8	119.2	100.6	82.0	-	134.7	20.1	134.7	133.1	114.4	95.7	77.1	-				
	62	141.5	18.1	141.5	141.5	141.5	123.0	104.4	85.8	129.9	20.0	129.9	129.9	129.9	115.2	96.5	77.8				
	57	144.4	18.1	144.4	144.4	135.6	117.1	98.5	79.9	133.6	20.1	133.6	133.6	125.3	106.6	88.0	69.3				
5250	77	177.4	18.9	109.8	77.2	56.0	-	-	-	160.8	20.9	109.2	72.0	50.7	-	-	-				
	72	163.7	18.6	131.8	110.6	89.4	68.2	-	-	148.4	20.5	126.8	105.5	84.3	63.0	-	-				
	67	150.0	18.3	150.0	144.0	122.8	101.6	80.4	-	135.9	20.1	135.9	135.9	117.8	96.5	75.3	-				
	62	142.9	18.1	142.9	142.9	146.6	125.4	104.2	82.9	131.0	20.0	131.0	131.0	131.0	118.0	96.4	75.2				
	57	145.8	18.1	145.8	139.8	118.5	97.3	76.1	-	134.8	20.1	134.8	134.8	129.1	108.2	86.5	65.2				
6000	77	179.0	18.9	128.1	81.5	57.6	-	-	-	162.3	20.9	131.9	76.1	52.2	-	-	-				
	72	165.2	18.6	139.8	115.9	92.0	68.2	-	-	149.7	20.5	134.5	110.6	86.7	62.8	-	-				
	67	151.4	18.3	151.4	150.3	126.4	102.6	78.7	-	137.1	20.1	137.1	137.1	121.3	97.4	73.5	-				
	62	144.2	18.1	144.2	144.2	151.7	127.8	103.9	80.1	132.2	20.0	132.2	132.2	132.2	120.9	96.4	72.5				
	57	147.1	18.2	147.1	143.9	120.0	96.1	72.3	-	136.0	20.1	136.0	136.0	132.8	109.8	85.0	61.1				
6750	72	167.3	18.7	151.0	124.5	97.9	71.4	-	-	151.6	20.6	146.3	119.6	92.8	66.1	-	-				
	67	153.3	18.3	153.3	152.8	134.6	108.0	81.5	-	138.9	20.2	138.9	138.9	129.8	103.0	76.3	-				
	62	146.0	18.1	146.0	146.0	149.8	123.2	96.7	70.2	133.9	20.0	133.9	133.9	133.9	113.5	86.4	59.6				
	57	149.0	18.2	149.0	149.0	147.4	120.9	94.3	67.8	137.7	20.1	137.7	137.7	136.1	109.9	82.6	55.9				
	7500	72	169.4	18.7	162.2	133.0	103.9	74.7	-	-	153.5	20.6	153.5	128.6	99.0	69.4	-	-			
67		155.3	18.4	155.3	155.3	142.7	113.5	84.3	-	140.7	20.3	140.7	140.7	138.3	108.7	79.1	-				
62		147.9	18.2	147.9	147.9	147.9	118.7	89.5	60.3	135.6	20.1	135.6	135.6	135.6	106.0	76.4	46.8				
57		150.9	18.3	150.9	150.9	150.9	121.7	92.5	63.3	139.5	20.2	139.5	139.5	139.5	109.9	80.3	50.6				

<sup>1</sup> These capacities are gross ratings. For net capacity, deduct supply air blower motor, MBh. Example: Refer to the appropriate Blower Performance Table for the BHP of the supply air blower motor, MBh = 3.415 x kW and kW = BHP x 0.746 ÷ nameplate rated motor efficiency.

<sup>2</sup> These ratings include the condenser fan motors and the compressor motors but not the supply air blower motor.

**PC240/NC240**

Air on Evaporator Coil		Temperature of Air on Condenser Coil																
CFM	WB (°F)	Total Capacity <sup>1</sup> (MBh)	Total Input (kW) <sup>2</sup>	Sensible Capacity (MBh)						Total Capacity <sup>1</sup> (MBh)	Total Input (kW) <sup>2</sup>	Sensible Capacity (MBh)						
				Return Dry Bulb (°F)								Return Dry Bulb (°F)						
				90	85	80	75	70	65			90	85	80	75	70	65	
		<b>75°F</b>								<b>85°F</b>								
6000	77	291.6	15.5	130.3	106.9	83.5	-	-	-	282.9	17.2	129.6	106.1	82.6	-	-	-	
	72	272.3	15.2	169.8	146.3	122.9	99.5	-	-	261.4	16.8	167.2	143.7	120.2	96.7	-	-	
	67	252.9	14.9	209.2	185.8	162.4	138.9	115.5	-	239.8	16.5	204.8	181.3	157.8	134.3	110.9	-	
	62	232.6	14.7	232.6	220.7	195.8	172.4	149.0	125.5	223.0	16.3	223.0	217.0	193.5	170.0	146.6	123.1	
	57	235.8	14.7	235.8	228.8	205.4	181.9	158.5	135.1	226.3	16.3	226.3	222.0	198.5	175.0	151.6	128.1	
7000	77	302.5	15.5	144.0	117.5	91.0	-	-	-	291.7	17.2	142.1	115.7	89.4	-	-	-	
	72	282.4	15.2	187.0	160.5	134.0	107.5	-	-	269.5	16.9	182.8	156.4	130.1	103.8	-	-	
	67	262.3	15.0	230.0	203.5	177.0	150.5	123.9	-	247.3	16.6	223.5	197.1	170.8	144.4	118.1	-	
	62	241.3	14.8	241.3	235.3	213.5	188.4	160.5	134.0	229.9	16.4	229.9	227.0	209.4	183.1	156.7	130.4	
	57	244.6	14.7	244.6	241.1	223.8	199.2	170.8	144.3	233.4	16.4	233.4	231.2	214.8	188.5	162.1	135.8	
8000	77	313.4	15.5	157.8	128.2	98.6	-	-	-	300.6	17.3	154.6	125.4	96.2	-	-	-	
	72	292.5	15.2	204.3	174.7	145.1	115.5	-	-	277.7	17.0	198.4	169.2	140.0	110.8	-	-	
	67	271.7	15.0	250.8	221.2	191.6	162.0	132.4	-	254.8	16.7	242.1	212.9	183.7	154.5	125.3	-	
	62	249.9	14.8	249.9	249.9	231.2	204.4	172.0	142.4	236.9	16.4	236.9	236.9	225.3	196.1	166.9	137.7	
	57	253.3	14.7	253.3	253.3	242.3	216.4	183.1	153.5	240.5	16.4	240.5	240.5	231.1	201.9	172.7	143.5	
9000	72	302.9	15.2	218.5	186.3	154.2	122.0	-	-	286.0	17.0	212.2	180.3	148.3	116.4	-	-	
	67	281.3	14.9	270.8	235.8	203.6	171.5	139.3	-	262.4	16.7	256.1	226.7	194.7	162.8	130.9	-	
	62	258.8	14.7	258.8	258.8	249.4	218.6	185.1	153.0	244.0	16.4	244.0	244.0	238.2	206.2	174.3	142.4	
	57	262.3	14.7	262.3	262.3	256.8	226.5	192.5	160.4	247.7	16.4	247.7	247.7	243.0	211.0	179.1	147.2	
	72	313.2	15.2	232.6	197.9	163.3	128.6	-	-	294.2	17.0	226.0	191.4	156.7	122.1	-	-	
10000	67	290.8	14.9	290.8	250.3	215.6	180.9	146.3	-	270.0	16.7	270.0	240.4	205.7	171.1	136.4	-	
	62	267.6	14.7	267.6	267.6	267.6	232.9	198.2	163.6	251.0	16.4	251.0	251.0	251.0	216.3	181.7	147.0	
	57	271.3	14.6	271.3	271.3	271.3	236.6	201.9	167.2	254.8	16.4	254.8	254.8	254.8	220.1	185.5	150.8	
			<b>95°F</b>								<b>105°F</b>							
	6000	77	274.1	18.8	128.8	105.3	81.8	-	-	-	254.0	21.0	122.0	98.5	75.1	-	-	-
72		250.4	18.5	164.6	141.0	117.5	94.0	-	-	233.3	20.6	158.2	134.8	111.3	87.9	-	-	
67		226.8	18.1	200.3	176.8	153.3	129.8	106.2	-	212.6	20.3	194.5	171.1	147.6	124.2	100.7	-	
62		213.3	17.8	213.3	213.3	191.2	167.7	144.2	120.7	200.4	20.0	200.4	200.4	181.8	158.3	134.9	111.4	
57		216.9	17.9	216.9	215.2	191.7	168.1	144.6	121.1	203.4	19.9	203.4	202.5	180.1	156.6	133.2	109.7	
7000	77	280.9	19.0	140.1	113.9	87.8	-	-	-	261.2	21.2	137.6	107.4	81.1	-	-	-	
	72	256.6	18.6	178.5	152.3	126.2	100.0	-	-	239.9	20.8	173.0	146.7	120.3	94.0	-	-	
	67	232.4	18.2	216.9	190.7	164.6	138.4	112.3	-	218.7	20.4	208.5	185.9	159.6	133.2	106.9	-	
	62	218.6	18.0	218.6	218.6	205.3	177.8	153.0	126.9	206.0	20.1	206.0	206.0	196.5	169.4	143.8	117.4	
	57	222.3	18.0	222.3	221.4	205.8	177.8	153.5	127.3	209.1	20.1	209.1	208.7	194.6	167.3	141.9	115.6	
8000	77	287.7	19.1	151.4	122.6	93.8	-	-	-	268.3	21.3	153.2	116.4	87.1	-	-	-	
	72	262.9	18.7	192.4	163.6	134.8	106.1	-	-	246.5	20.9	187.8	158.6	129.3	100.1	-	-	
	67	238.0	18.4	233.5	204.7	175.9	147.1	118.3	-	224.7	20.6	222.4	200.8	171.5	142.3	113.0	-	
	62	223.9	18.1	223.9	223.9	219.4	187.8	161.8	133.0	211.7	20.3	211.7	211.7	211.2	180.5	152.7	123.5	
	57	227.7	18.1	227.7	227.7	219.9	187.4	162.3	133.5	214.8	20.2	214.8	214.8	209.2	178.1	150.7	121.4	
9000	72	269.0	18.8	205.9	174.2	142.5	110.8	-	-	253.1	21.0	202.1	170.0	137.9	105.8	-	-	
	67	243.6	18.4	241.3	217.6	185.9	154.2	122.4	-	230.7	20.6	229.6	214.1	182.8	150.7	118.6	-	
	62	229.2	18.1	229.2	229.2	226.9	193.8	163.5	131.8	217.4	20.3	217.4	217.4	217.1	184.3	152.9	120.8	
	57	233.0	18.2	233.0	233.0	229.1	195.6	165.7	134.0	220.6	20.3	220.6	220.6	217.8	184.8	153.6	121.5	
	72	275.2	18.8	219.5	184.8	150.2	115.5	-	-	259.8	21.0	216.3	181.3	146.4	111.4	-	-	
10000	67	249.2	18.5	249.2	230.5	195.9	161.2	126.6	-	236.8	20.7	236.8	227.4	194.2	159.2	124.2	-	
	62	234.4	18.2	234.4	234.4	234.4	199.8	165.1	130.5	223.1	20.4	223.1	223.1	223.1	188.2	153.2	118.2	
	57	238.4	18.2	238.4	238.4	238.4	203.7	169.1	134.4	226.4	20.3	226.4	226.4	226.4	191.5	156.5	121.5	

## PC240/NC240 (Continued)

Air on Evaporator Coil		Temperature of Air on Condenser Coil																															
CFM	WB (°F)	Total Capacity <sup>1</sup> (MBh)	Total Input (kW) <sup>2</sup>	Sensible Capacity (MBh)						Total Capacity <sup>1</sup> (MBh)	Total Input (kW) <sup>2</sup>	Sensible Capacity (MBh)																					
				Return Dry Bulb (°F)								Return Dry Bulb (°F)																					
				90	85	80	75	70	65			90	85	80	75	70	65																
115°F																	125°F																
6000	77	233.9	23.2	115.1	91.7	68.3	-	-	-	213.8	25.4	108.3	85.0	61.6	-	-	-																
	72	216.2	22.8	151.9	128.5	105.1	81.8	-	199.1	25.0	145.6	122.3	99.0	75.6	-	-	-																
	67	198.5	22.4	188.7	165.3	141.9	118.6	95.2	184.4	24.6	182.9	159.6	136.3	113.0	89.6	-	-																
	62	187.4	22.2	187.4	187.4	172.3	148.9	125.5	102.1	174.5	24.3	174.5	174.5	162.9	139.5	116.2	92.9																
	57	189.8	22.0	189.8	189.8	168.5	145.1	121.7	98.3	176.3	24.0	176.3	176.3	156.9	133.6	110.2	86.9																
7000	77	241.4	23.4	135.1	100.9	74.4	-	-	221.7	25.6	132.6	94.5	67.7	-	-	-	-																
	72	223.2	23.0	167.6	141.0	114.5	87.9	-	206.4	25.2	162.1	135.4	108.6	81.9	-	-	-																
	67	204.9	22.6	200.0	181.1	154.6	128.0	101.5	191.2	24.8	191.2	176.3	149.5	122.8	96.1	-	-																
	62	193.5	22.3	193.5	193.5	187.6	161.1	134.5	108.0	180.9	24.5	180.9	180.9	178.8	152.7	125.3	98.6																
	57	195.9	22.1	195.9	195.9	183.4	156.9	130.4	103.8	182.7	24.1	182.7	182.7	172.3	146.5	118.8	92.1																
8000	77	249.0	23.5	155.0	110.2	80.5	-	-	229.6	25.7	156.9	103.9	73.8	-	-	-	-																
	72	230.1	23.1	183.2	153.5	123.8	94.1	-	213.8	25.3	178.6	148.4	118.3	88.2	-	-	-																
	67	211.3	22.8	211.3	196.8	167.2	137.5	107.8	198.0	24.9	198.0	192.9	162.8	132.7	102.5	-	-																
	62	199.5	22.5	199.5	199.5	202.9	173.2	143.5	113.9	187.3	24.7	187.3	187.3	165.9	134.4	104.3	-																
	57	202.0	22.3	202.0	202.0	198.4	168.7	139.0	109.3	189.2	24.3	189.2	189.2	187.6	159.3	127.4	97.2																
9000	72	237.2	23.2	198.2	165.7	133.2	100.7	-	221.3	25.4	194.3	161.4	128.6	95.7	-	-	-																
	67	217.8	22.8	217.8	210.6	179.8	147.3	114.9	205.0	25.0	205.0	205.0	176.8	143.9	111.1	-	-																
	62	205.7	22.5	205.7	205.7	207.4	174.9	142.4	109.9	193.9	24.7	193.9	193.9	193.9	165.4	131.9	99.0																
	57	208.3	22.3	208.3	208.3	206.4	174.0	141.5	109.0	195.9	24.4	195.9	195.9	195.1	163.2	129.4	96.5																
	10000	72	244.3	23.2	213.2	177.9	142.6	107.3	-	228.9	25.4	210.0	174.4	138.8	103.2	-	-	-															
67		224.4	22.9	224.4	224.4	192.5	157.2	121.9	211.9	25.1	211.9	211.9	190.8	155.2	119.6	-	-																
62		211.8	22.6	211.8	211.8	211.8	176.5	141.3	106.0	200.5	24.8	200.5	200.5	200.5	164.9	129.3	93.7																
57		214.5	22.4	214.5	214.5	214.5	179.2	143.9	108.6	202.6	24.4	202.6	202.6	202.6	167.0	131.4	95.8																

<sup>1</sup> These capacities are gross ratings. For net capacity, deduct supply air blower motor, MBh. Example: Refer to the appropriate Blower Performance Table for the BHP of the supply air blower motor, MBh = 3.415 x kW and kW = BHP x 0.746 ÷ nameplate rated motor efficiency.

<sup>2</sup> These ratings include the condenser fan motors and the compressor motors but not the supply air blower motor.

**PD240/ND240**

Air on Evaporator Coil		Temperature of Air on Condenser Coil																
CFM	WB (°F)	Total Capacity <sup>1</sup> (MBh)	Total Input (kW) <sup>2</sup>	Sensible Capacity (MBh)						Total Capacity <sup>1</sup> (MBh)	Total Input (kW) <sup>2</sup>	Sensible Capacity (MBh)						
				Return Dry Bulb (°F)								Return Dry Bulb (°F)						
				90	85	80	75	70	65			90	85	80	75	70	65	
		75°F								85°F								
6000	77	314.8	15.1	142.6	118.0	93.5	-	-	-	300.0	17.0	137.0	112.4	87.8	-	-	-	
	72	285.9	14.8	177.4	152.9	128.3	103.8	-	-	271.7	16.7	171.9	147.4	122.8	98.3	-	-	
	67	257.1	14.5	212.3	187.7	163.2	138.6	114.0	-	243.5	16.4	206.9	182.4	157.8	133.2	108.7	-	
	62	239.1	14.2	239.1	225.1	200.5	175.9	151.4	126.8	227.5	16.1	227.5	219.3	194.7	170.2	145.6	121.1	
	57	239.5	14.3	239.5	237.8	213.3	188.7	164.1	139.6	230.2	16.2	230.2	227.8	203.3	178.7	154.1	129.6	
7000	77	321.1	15.2	154.7	127.4	100.0	-	-	-	305.7	17.1	148.9	121.5	94.1	-	-	-	
	72	291.7	14.9	192.0	164.7	137.3	110.0	-	-	276.9	16.8	186.4	159.0	131.6	104.2	-	-	
	67	262.3	14.6	229.3	201.9	174.6	147.2	119.9	-	248.1	16.5	223.9	196.5	169.1	141.7	114.4	-	
	62	243.9	14.3	243.9	236.9	214.5	188.2	159.8	132.5	231.9	16.2	231.9	227.7	208.7	181.3	154.0	126.6	
	57	244.3	14.5	244.3	243.5	228.2	203.0	173.5	146.1	234.5	16.3	234.5	233.4	217.9	190.5	163.1	135.7	
8000	77	327.5	15.3	166.9	136.7	106.6	-	-	-	311.4	17.2	160.9	130.7	100.5	-	-	-	
	72	297.5	15.0	206.6	176.5	146.3	116.2	-	-	282.1	16.9	200.9	170.7	140.5	110.2	-	-	
	67	267.5	14.8	246.3	216.2	186.0	155.9	125.7	-	252.8	16.6	240.9	210.7	180.5	150.2	120.0	-	
	62	248.8	14.4	248.8	248.8	228.6	200.4	168.3	138.1	236.2	16.2	236.2	236.2	222.7	192.5	162.3	132.1	
	57	249.2	14.6	249.2	249.2	243.2	217.3	182.9	152.7	238.9	16.4	238.9	238.9	232.5	202.2	172.0	141.8	
9000	72	303.3	15.2	219.3	184.7	150.2	115.7	-	-	287.2	17.1	212.0	178.0	144.0	110.1	-	-	
	67	272.7	14.9	262.1	225.5	191.0	156.5	122.0	-	257.4	16.8	251.5	219.1	185.1	151.1	117.1	-	
	62	253.6	14.6	253.6	253.6	234.7	201.2	165.6	131.1	240.5	16.4	240.5	240.5	228.4	194.4	160.4	126.5	
	57	254.0	14.7	254.0	254.0	249.7	217.3	180.6	146.1	243.3	16.6	243.3	243.3	238.4	204.4	170.4	136.4	
	72	309.0	15.4	231.9	193.0	154.1	115.2	-	-	292.4	17.3	223.1	185.4	147.6	109.9	-	-	
10000	67	277.8	15.1	277.8	234.9	196.0	157.1	118.2	-	262.0	17.0	262.0	227.4	189.7	151.9	114.2	-	
	62	258.4	14.7	258.4	258.4	240.8	201.9	163.0	124.1	244.8	16.6	244.8	244.8	234.1	196.4	158.6	120.9	
	57	258.8	14.9	258.8	258.8	256.2	217.3	178.4	139.5	247.6	16.8	247.6	247.6	244.3	206.6	168.8	131.1	
			95°F								105°F							
	6000	77	285.2	18.9	131.3	106.8	82.2	-	-	-	264.8	21.2	126.0	101.4	76.8	-	-	-
72		257.5	18.6	166.4	141.9	117.3	92.8	-	-	240.1	20.9	161.0	136.3	111.7	87.1	-	-	
67		229.9	18.2	201.5	177.0	152.4	127.9	103.3	-	215.3	20.5	195.9	171.3	146.7	122.1	97.5	-	
62		216.0	18.0	216.0	213.5	189.0	164.4	139.9	115.3	203.2	20.2	203.2	202.0	183.1	158.5	133.9	109.2	
57		220.8	18.1	220.8	217.8	193.2	168.7	144.1	119.6	209.8	20.4	209.8	206.5	181.9	157.3	132.6	108.0	
7000	77	290.2	19.0	143.1	115.7	88.3	-	-	-	269.2	21.3	142.0	110.2	82.7	-	-	-	
	72	262.1	18.6	180.8	153.4	126.0	98.5	-	-	244.1	20.9	175.3	147.8	120.3	92.8	-	-	
	67	234.0	18.3	218.5	191.1	163.7	136.3	108.8	-	219.0	20.6	208.6	185.4	157.9	130.4	102.9	-	
	62	219.8	18.0	219.8	218.6	202.9	174.5	148.1	120.7	206.6	20.3	206.6	206.0	197.1	169.1	142.1	114.6	
	57	224.7	18.2	224.7	223.2	207.5	177.9	152.6	125.2	213.3	20.5	213.3	211.7	195.8	167.2	140.8	113.3	
8000	77	295.2	19.0	154.9	124.6	94.3	-	-	-	273.7	21.4	158.1	119.0	88.5	-	-	-	
	72	266.6	18.7	195.2	164.9	134.6	104.3	-	-	248.1	21.0	189.7	159.3	128.9	98.4	-	-	
	67	238.0	18.4	235.5	205.2	174.9	144.6	114.3	-	222.6	20.7	221.3	199.6	169.2	138.8	108.3	-	
	62	223.6	18.1	223.6	223.6	216.9	184.6	156.3	126.0	210.0	20.4	210.0	210.0	211.2	179.7	150.3	119.9	
	57	228.6	18.3	228.6	228.6	221.8	187.2	161.2	130.9	216.9	20.6	216.9	216.9	209.7	177.2	148.9	118.5	
9000	72	271.1	19.0	204.8	171.3	137.9	104.4	-	-	252.2	21.2	199.3	165.7	132.2	98.6	-	-	
	67	242.1	18.6	240.8	212.6	179.1	145.7	112.3	-	226.2	20.9	225.6	207.1	173.6	140.0	106.4	-	
	62	227.4	18.3	227.4	227.4	222.1	187.7	155.2	121.8	213.4	20.6	213.4	213.4	213.0	179.0	145.9	112.4	
	57	232.5	18.5	232.5	232.5	227.1	191.5	160.2	126.8	220.4	20.8	220.4	220.4	215.2	180.5	148.0	114.5	
	72	275.7	19.2	214.3	177.7	141.1	104.5	-	-	256.2	21.5	208.9	172.2	135.5	98.8	-	-	
10000	67	246.1	18.8	246.1	219.9	183.4	146.8	110.2	-	229.8	21.1	229.8	214.6	177.9	141.2	104.6	-	
	62	231.2	18.6	231.2	231.2	227.3	190.8	154.2	117.6	216.8	20.8	216.8	216.8	214.9	178.2	141.5	104.8	
	57	236.4	18.7	236.4	236.4	232.5	195.9	159.3	122.7	223.9	21.0	223.9	223.9	220.6	183.9	147.2	110.5	

**PD240/ND240 (Continued)**

Air on Evaporator Coil		Temperature of Air on Condenser Coil															
CFM	WB (°F)	Total Capacity <sup>1</sup> (MBh)	Total Input (kW) <sup>2</sup>	Sensible Capacity (MBh)						Total Capacity <sup>1</sup> (MBh)	Total Input (kW) <sup>2</sup>	Sensible Capacity (MBh)					
				Return Dry Bulb (°F)								Return Dry Bulb (°F)					
				90	85	80	75	70	65			90	85	80	75	70	65
				<b>115°F</b>						<b>125°F</b>							
6000	77	244.4	23.6	120.7	96.0	71.4	-	-	-	224.0	25.9	115.4	90.7	65.9	-	-	-
	72	222.6	23.2	155.5	130.8	106.2	81.5	-	-	205.1	25.5	150.0	125.3	100.6	75.8	-	-
	67	200.8	22.8	190.3	165.6	140.9	116.3	91.6	-	186.2	25.1	184.7	159.9	135.2	110.5	85.7	-
	62	190.4	22.5	190.4	190.4	177.2	152.5	127.8	103.2	177.6	24.8	177.6	177.6	171.3	146.5	121.8	97.1
	57	198.8	22.8	198.8	195.2	170.5	145.8	121.2	96.5	187.8	25.1	187.8	183.9	159.2	134.4	109.7	85.0
7000	77	248.3	23.6	140.9	104.7	77.1	-	-	-	227.3	25.9	139.8	99.1	71.4	-	-	-
	72	226.1	23.2	169.8	142.2	114.6	87.0	-	-	208.1	25.5	164.3	136.6	108.9	81.3	-	-
	67	204.0	22.9	198.7	179.8	152.2	124.6	97.0	-	188.9	25.2	188.8	174.1	146.4	118.7	91.1	-
	62	193.4	22.6	193.4	193.4	191.3	163.7	136.1	108.5	180.2	24.8	180.2	180.2	180.2	158.3	130.1	102.4
	57	201.9	22.8	201.9	200.1	184.1	156.5	128.9	101.3	190.6	25.1	190.6	188.6	172.4	145.8	117.0	89.3
8000	77	252.1	23.7	161.2	113.3	82.7	-	-	-	230.6	26.0	164.3	107.6	76.9	-	-	-
	72	229.6	23.3	184.1	153.6	123.1	92.5	-	-	211.1	25.6	178.6	148.0	117.3	86.7	-	-
	67	207.1	22.9	207.1	194.0	163.4	132.9	102.4	-	191.7	25.2	191.7	188.3	157.7	127.0	96.4	-
	62	196.4	22.6	196.4	196.4	205.4	174.9	144.4	113.8	182.8	24.9	182.8	182.8	182.8	170.1	138.4	107.8
	57	205.1	22.9	205.1	205.1	197.7	167.2	136.6	106.1	193.3	25.2	193.3	193.3	185.7	157.2	124.4	93.7
9000	72	233.2	23.5	193.9	160.2	126.5	92.8	-	-	214.2	25.8	188.4	154.6	120.8	87.0	-	-
	67	210.3	23.2	210.3	201.6	168.0	134.3	100.6	-	194.5	25.5	194.5	194.5	162.4	128.6	94.8	-
	62	199.4	22.8	199.4	199.4	203.9	170.3	136.6	102.9	185.4	25.1	185.4	185.4	185.4	161.6	127.3	93.5
	57	208.3	23.1	208.3	208.3	203.2	169.5	135.9	102.2	196.1	25.4	196.1	196.1	191.3	158.5	123.7	89.9
	72	236.7	23.8	203.6	166.8	129.9	93.1	-	-	217.2	26.1	198.2	161.3	124.3	87.4	-	-
10000	67	213.5	23.4	213.5	209.3	172.5	135.7	98.9	-	197.2	25.7	197.2	197.2	167.1	130.2	93.2	-
	62	202.5	23.1	202.5	202.5	202.5	165.6	128.8	92.0	188.1	25.4	188.1	188.1	188.1	153.1	116.1	79.2
	57	211.4	23.4	211.4	211.4	208.7	171.9	135.1	98.3	198.9	25.7	198.9	198.9	196.8	159.9	123.0	86.0

- <sup>1</sup> These capacities are gross ratings. For net capacity, deduct supply air blower motor, MBh. Example: Refer to the appropriate Blower Performance Table for the BHP of the supply air blower motor, MBh = 3.415 x kW and kW = BHP x 0.746 ÷ nameplate rated motor efficiency.
- <sup>2</sup> These ratings include the condenser fan motors and the compressor motors but not the supply air blower motor.

## Heat Pump And Air Handler Heating Capacities

## PC090 / NC090

Air Over Evaporator Coil		Capacity <sup>1</sup> & kW	Outdoor Temperature (°F @ 72% RH)							
CFM	DB (°F)		-10	0	10	20	30	40	50	60
2250	55	MBH	34.0	39.6	46.2	53.9	62.9	73.5	86.0	100.6
		KW	4.9	5.3	5.6	6.0	6.3	6.7	7.0	7.3
	70	MBH	31.0	36.6	43.2	50.9	60.0	70.6	83.0	97.6
		KW	5.8	6.1	6.5	6.8	7.1	7.5	7.8	8.2
	80	MBH	28.7	34.3	40.9	48.6	57.7	68.3	80.7	95.3
		KW	6.4	6.8	7.1	7.4	7.8	8.1	8.5	8.8
3000	55	MBH	35.3	40.9	47.5	55.2	64.3	74.9	87.3	101.9
		KW	4.7	5.1	5.4	5.8	6.1	6.5	6.8	7.1
	70	MBH	32.4	38.0	44.5	52.3	61.3	71.9	84.4	99.0
		KW	5.6	5.9	6.3	6.6	6.9	7.3	7.6	8.0
	80	MBH	30.1	35.7	42.3	50.0	59.0	69.6	82.1	96.7
		KW	6.2	6.5	6.9	7.2	7.6	7.9	8.3	8.6
3750	55	MBH	36.6	42.2	48.8	56.5	65.6	76.2	88.6	103.2
		KW	5.2	5.6	5.9	6.3	6.6	7.0	7.3	7.6
	70	MBH	33.7	39.3	45.8	53.6	62.6	73.2	85.7	100.3
		KW	6.1	6.4	6.8	7.1	7.4	7.8	8.1	8.5
	80	MBH	31.4	37.0	43.6	51.3	60.3	70.9	83.4	98.0
		KW	6.7	7.0	7.4	7.7	8.1	8.4	8.8	9.1

<sup>1</sup> These capacities do not include the supply air blower motor heat. For net capacity, add motor heat, MBh. Example: Refer to the appropriate Blower Performance Table for the BHP of the supply air blower motor, MBh = 3.415 x kW and kW = BHP x 0.746 ÷ nameplate rated motor efficiency.

## PC120 / NC120

Air Over Evaporator Coil		Capacity <sup>1</sup> & kW	Outdoor Temperature (°F @ 72% RH)							
CFM	DB (°F)		-10	0	10	20	30	40	50	60
3000	55	MBH	29.1	36.4	45.3	56.0	69.0	84.7	103.8	126.8
		KW	6.9	7.3	7.6	8.0	8.3	8.7	9.1	9.4
	70	MBH	26.3	33.6	42.4	53.1	66.1	81.8	100.9	124.0
		KW	8.2	8.6	8.9	9.3	9.7	10.0	10.4	10.7
	80	MBH	24.2	31.5	40.4	51.1	64.1	79.8	98.8	121.9
		KW	9.2	9.6	10.0	10.3	10.7	11.1	11.4	11.8
4000	55	MBH	37.4	44.7	53.5	64.3	77.2	93.0	112.0	135.1
		KW	6.7	7.1	7.4	7.8	8.1	8.5	8.9	9.2
	70	MBH	34.5	41.8	50.7	61.4	74.4	90.1	109.2	132.2
		KW	8.0	8.4	8.7	9.1	9.5	9.8	10.2	10.6
	80	MBH	32.5	39.8	48.6	59.3	72.3	88.0	107.1	130.2
		KW	9.0	9.4	9.8	10.1	10.5	10.9	11.2	11.6
5000	55	MBH	44.1	51.4	60.3	71.0	84.0	99.7	118.7	141.8
		KW	6.9	7.2	7.6	8.0	8.3	8.7	9.0	9.4
	70	MBH	41.3	48.6	57.4	68.1	81.1	96.8	115.9	138.9
		KW	8.2	8.6	8.9	9.3	9.6	10.0	10.4	10.7
	80	MBH	39.2	46.5	55.3	66.1	79.0	94.8	113.8	136.9
		KW	9.2	9.6	9.9	10.3	10.7	11.0	11.4	11.7

<sup>1</sup> These capacities do not include the supply air blower motor heat. For net capacity, add motor heat, MBh. Example: Refer to the appropriate Blower Performance Table for the BHP of the supply air blower motor, MBh = 3.415 x kW and kW = BHP x 0.746 ÷ nameplate rated motor efficiency.



**PC180 / NC180**

Air Over Evaporator Coil		Capacity <sup>1</sup> & kW	Outdoor Temperature (°F @ 72% RH)							
CFM	DB (°F)		-10	0	10	20	30	40	50	60
4500	55	MBH	68.2	80.0	93.8	110.0	129.1	151.5	177.8	208.7
		KW	11.8	12.2	12.7	13.2	13.7	14.1	14.6	15.1
	70	MBH	61.5	73.2	87.0	103.2	122.3	144.7	171.0	201.9
		KW	13.5	14.0	14.4	14.9	15.4	15.9	16.3	16.8
	80	MBH	57.6	69.3	83.1	99.3	118.4	140.8	167.1	198.0
		KW	15.0	15.5	16.0	16.4	16.9	17.4	17.9	18.3
6000	55	MBH	74.0	85.8	99.6	115.8	134.9	157.3	183.6	214.5
		KW	11.2	11.7	12.2	12.6	13.1	13.6	14.1	14.6
	70	MBH	67.3	79.0	92.8	109.0	128.1	150.5	176.8	207.7
		KW	12.9	13.4	13.9	14.4	14.8	15.3	15.8	16.3
	80	MBH	63.4	75.1	88.9	105.1	124.2	146.6	172.9	203.8
		KW	14.5	14.9	15.4	15.9	16.4	16.8	17.3	17.8
7500	55	MBH	72.4	84.1	97.9	114.1	133.2	155.6	181.9	212.8
		KW	12.0	12.5	13.0	13.4	13.9	14.4	14.9	15.4
	70	MBH	65.6	77.3	91.1	107.4	126.4	148.8	175.1	206.0
		KW	13.7	14.2	14.7	15.2	15.6	16.1	16.6	17.1
	80	MBH	61.7	73.4	87.3	103.5	122.5	144.9	171.2	202.1
		KW	15.3	15.7	16.2	16.7	17.2	17.6	18.1	18.6

<sup>1</sup> These capacities do not include the supply air blower motor heat. For net capacity, add motor heat, MBh. Example: Refer to the appropriate Blower Performance Table for the BHP of the supply air blower motor, MBh = 3.415 x kW and kW = BHP x 0.746 ÷ nameplate rated motor efficiency.

**PD180 / ND180**

Air Over Evaporator Coil		Capacity <sup>1</sup> & kW	Outdoor Temperature (°F @ 72% RH)							
CFM	DB (°F)		-10	0	10	20	30	40	50	60
4500	55	MBH	65.6	77.0	90.3	105.8	123.9	145.1	169.7	198.5
		KW	10.0	10.5	11.1	11.6	12.2	12.7	13.3	13.8
	70	MBH	62.2	73.6	86.9	102.4	120.5	141.6	166.3	195.1
		KW	12.0	12.5	13.1	13.6	14.2	14.7	15.3	15.8
	80	MBH	59.5	70.9	84.1	99.7	117.8	138.9	163.6	192.4
		KW	13.4	13.9	14.5	15.0	15.6	16.1	16.7	17.2
6000	55	MBH	71.6	83.0	96.3	111.8	129.9	151.0	175.7	204.5
		KW	9.6	10.2	10.7	11.3	11.8	12.4	12.9	13.4
	70	MBH	68.1	79.5	92.8	108.3	126.5	147.6	172.3	201.1
		KW	11.6	12.2	12.7	13.3	13.8	14.3	14.9	15.4
	80	MBH	65.4	76.8	90.1	105.6	123.7	144.9	169.6	198.3
		KW	13.0	13.6	14.1	14.7	15.2	15.8	16.3	16.9
7500	55	MBH	74.0	85.4	98.7	114.2	132.4	153.5	178.2	207.0
		KW	11.3	11.8	12.4	12.9	13.5	14.0	14.6	15.1
	70	MBH	70.6	82.0	95.3	110.8	128.9	150.1	174.7	203.5
		KW	13.3	13.8	14.4	14.9	15.5	16.0	16.6	17.1
	80	MBH	67.9	79.3	92.6	108.1	126.2	147.4	172.0	200.8
		KW	14.7	15.3	15.8	16.4	16.9	17.5	18.0	18.5

<sup>1</sup> These capacities do not include the supply air blower motor heat. For net capacity, add motor heat, MBh. Example: Refer to the appropriate Blower Performance Table for the BHP of the supply air blower motor, MBh = 3.415 x kW and kW = BHP x 0.746 ÷ nameplate rated motor efficiency.

**PC240 / NC240**

Air Over Evaporator Coil		Capacity <sup>1</sup> & kW	Outdoor Temperature (°F @ 72% RH)							
CFM	DB (°F)		-10	0	10	20	30	40	50	60
6000	55	MBH	84.3	98.8	115.6	135.0	157.4	183.2	212.9	247.3
		KW	13.7	14.4	15.2	15.9	16.6	17.3	18.1	18.8
	70	MBH	90.0	104.5	121.3	140.7	163.1	188.8	218.6	253.0
		KW	16.1	16.8	17.6	18.3	19.0	19.7	20.5	21.2
	80	MBH	88.3	102.8	119.6	139.0	161.3	187.1	216.9	251.2
		KW	17.8	18.5	19.3	20.0	20.7	21.5	22.2	22.9
8000	55	MBH	88.8	103.4	120.2	139.5	161.9	187.7	217.4	251.8
		KW	13.2	13.9	14.7	15.4	16.1	16.8	17.6	18.3
	70	MBH	94.5	109.1	125.8	145.2	167.6	193.4	223.1	257.5
		KW	15.6	16.3	17.0	17.8	18.5	19.2	19.9	20.7
	80	MBH	92.8	107.3	124.1	143.5	165.9	191.6	221.4	255.8
		KW	17.3	18.0	18.8	19.5	20.2	20.9	21.7	22.4
9000	55	MBH	92.3	106.8	123.6	143.0	165.3	191.1	220.9	255.2
		KW	14.5	15.3	16.0	16.7	17.4	18.2	18.9	19.6
	70	MBH	97.9	112.5	129.3	148.7	171.0	196.8	226.6	260.9
		KW	16.9	17.7	18.4	19.1	19.8	20.6	21.3	22.0
	80	MBH	96.2	110.8	127.6	146.9	169.3	195.1	224.8	259.2
		KW	18.7	19.4	20.1	20.8	21.6	22.3	23.0	23.7

<sup>1</sup> These capacities do not include the supply air blower motor heat. For net capacity, add motor heat, MBh. Example: Refer to the appropriate Blower Performance Table for the BHP of the supply air blower motor, MBh = 3.415 x kW and kW = BHP x 0.746 ÷ nameplate rated motor efficiency.

**PD240 / ND240**

Air Over Evaporator Coil		Capacity <sup>1</sup> & kW	Outdoor Temperature (°F @ 72% RH)							
CFM	DB (°F)		-10	0	10	20	30	40	50	60
6000	55	MBH	64.6	79.5	97.4	118.8	144.3	174.9	211.4	255.1
		KW	15.7	16.5	17.3	18.1	19.0	19.8	20.6	21.4
	70	MBH	69.5	84.4	102.3	123.7	149.2	179.8	216.3	260.0
		KW	15.4	16.2	17.0	17.9	18.7	19.5	20.3	21.2
	80	MBH	63.3	78.3	96.2	117.5	143.1	173.6	210.2	253.8
		KW	17.2	18.0	18.8	19.6	20.5	21.3	22.1	23.0
8000	55	MBH	71.6	86.6	104.5	125.8	151.4	181.9	218.5	262.1
		KW	15.1	15.9	16.8	17.6	18.4	19.2	20.1	20.9
	70	MBH	76.5	91.5	109.4	130.7	156.3	186.8	223.4	267.0
		KW	14.8	15.6	16.5	17.3	18.1	19.0	19.8	20.6
	80	MBH	70.4	85.3	103.2	124.6	150.1	180.7	217.2	260.9
		KW	16.6	17.4	18.3	19.1	19.9	20.7	21.6	22.4
10000	55	MBH	73.3	88.3	106.1	127.5	153.1	183.6	220.1	263.8
		KW	15.3	16.1	17.0	17.8	18.6	19.4	20.3	21.1
	70	MBH	78.2	93.2	111.0	132.4	158.0	188.5	225.0	268.7
		KW	15.0	15.8	16.7	17.5	18.3	19.1	20.0	20.8
	80	MBH	72.1	87.0	104.9	126.3	151.8	182.4	218.9	262.6
		KW	16.8	17.6	18.5	19.3	20.1	20.9	21.8	22.6

<sup>1</sup> These capacities do not include the supply air blower motor heat. For net capacity, add motor heat, MBh. Example: Refer to the appropriate Blower Performance Table for the BHP of the supply air blower motor, MBh = 3.415 x kW and kW = BHP x 0.746 ÷ nameplate rated motor efficiency.

## Sound Performance

### Outdoor Sound Power Levels (dB), 60 Hz

Size (Tons)	Model	Sound Rating <sup>1</sup>	Octave Bands (Hz)							
			63	125	250	500	1000	2000	4000	8000
090 (7.5)	PC090	89	88	90	89	87	84	81	77	72
	YC090	89	88	89	89	87	84	81	78	73
120 (10.0)	PC120	89	88	90	89	87	84	81	77	72
	YC120	90	91	87	90	88	85	80	76	70
	YD120	90	92	89	91	88	85	80	77	71
150 (12.5)	YC150	91	96	88	90	89	86	82	77	71
	YD150	91	92	92	92	89	86	81	78	73
180 (15.0)	PC180	93	93	96	93	90	89	84	77	71
	PD180	93	93	96	93	90	89	84	77	71
	YC180	89	88	90	89	87	84	81	77	72
	YD180	89	88	90	89	87	84	81	77	72
240 (20.0)	PC240	93	93	96	93	90	89	84	77	71
	PD240	93	93	96	93	90	89	84	77	71
	YC240	93	93	96	93	90	89	84	77	71
	YD240	93	93	96	93	90	89	84	77	71

<sup>1</sup> Rated in accordance with ARI 270 Standard.

**Electrical Data - Outdoor Unit - HP Without Powered Convenience Outlet**

Model	Compressors					Outdoor Fan Motor		Pwr Conv Outlet	Minimum Circuit Ampacity <sup>1</sup>	Maximum Fuse Size (A) <sup>2</sup>
	Power Supply	Qty.	RLA (each)	MCC (each)	LRA (each)	Qty	FLA (each)	FLA		
PC090	208/230-3-60	1	25.0	39	164	2	2.1	0.0	35.5	45
	460-3-60	1	12.2	19	100	2	1.2	0.0	17.6	25
	575-3-60	1	9.0	14	78	2	0.9	0.0	13.1	20
PC120	208/230-3-60	2	15.6	24	110	2	3.0	0.0	41.2	50
	460-3-60	2	7.8	12	52	2	1.6	0.0	20.8	25
	575-3-60	2	5.8	9	39	2	1.4	0.0	15.8	20
PC180	208/230-3-60	2	25.0	39	164	4	2.1	0.0	64.7	80
	460-3-60	2	12.2	19	100	4	1.2	0.0	32.2	40
	575-3-60	2	9.0	14	78	4	0.9	0.0	24.0	30
PD180	208/230-3-60	2	25.0	39	164	4	2.1	0.0	64.7	80
	460-3-60	2	12.2	19	100	4	1.2	0.0	32.2	40
	575-3-60	2	9.0	14	78	4	0.9	0.0	24.0	30
PC240	208/230-3-60	2	30.1	47	225	4	3.0	0.0	79.8	100
	460-3-60	2	16.7	26	114	4	1.6	0.0	44.0	60
	575-3-60	2	12.2	19	80	4	1.4	0.0	32.9	45
PD240	208/230-3-60	2	30.1	47	225	4	3.0	0.0	79.8	100
	460-3-60	2	16.7	26	114	4	1.6	0.0	44.0	60
	575-3-60	2	12.2	19	80	4	1.4	0.0	32.9	45

<sup>1</sup> Based on three, 75°C insulated copper conductors in conduit and ambient of 30°C.

<sup>2</sup> Maximum fuse or maximum circuit breaker (HACR type per NEC).  
Refer to NEC/NFPA No. 70, Articles 440-11, 12 for information on minimum disconnect sizing.

**Electrical Data - Outdoor Unit - HP With Powered Convenience Outlet**

Model	Compressors					Outdoor Fan Motor		Pwr Conv Outlet	Minimum Circuit Ampacity <sup>1</sup>	Maximum Fuse Size (A) <sup>2</sup>
	Power Supply	Qty.	RLA (each)	MCC (each)	LRA (each)	Qty	FLA (each)	FLA		
PC090	208/230-3-60	1	25.0	39	164	2	2.1	10.0	45.5	60
	460-3-60	1	12.2	19	100	2	1.2	5.0	22.6	30
	575-3-60	1	9.0	14	78	2	0.9	4.0	17.1	25
PC120	208/230-3-60	2	15.6	24	110	2	3.0	10.0	51.2	60
	460-3-60	2	7.8	12	52	2	1.6	5.0	25.8	30
	575-3-60	2	5.8	9	39	2	1.4	4.0	19.8	25
PC180	208/230-3-60	2	25.0	39	164	4	2.1	10.0	74.7	90
	460-3-60	2	12.2	19	100	4	1.2	5.0	37.2	45
	575-3-60	2	9.0	14	78	4	0.9	4.0	28.0	35
PD180	208/230-3-60	2	25.0	39	164	4	2.1	10.0	74.7	90
	460-3-60	2	12.2	19	100	4	1.2	5.0	37.2	45
	575-3-60	2	9.0	14	78	4	0.9	4.0	28.0	35
PC240	208/230-3-60	2	30.1	47	225	4	3.0	10.0	89.8	110
	460-3-60	2	16.7	28	114	4	1.6	5.0	49.0	60
	575-3-60	2	12.2	19	80	4	1.4	4.0	36.9	45
PD240	208/230-3-60	2	30.1	47	225	4	3.0	10.0	89.8	110
	460-3-60	2	16.7	26	114	4	1.6	5.0	49.0	60
	575-3-60	2	12.2	19	80	4	1.4	4.0	36.9	45

<sup>1</sup> Based on three, 75°C insulated copper conductors in conduit and ambient of 30°C.

<sup>2</sup> Maximum fuse or maximum circuit breaker (HACR type per NEC).  
Refer to NEC/NFPA No. 70, Articles 440-11, 12 for information on minimum disconnect sizing.

# Heat Pump Units

## Typical PC090 Wiring Diagram

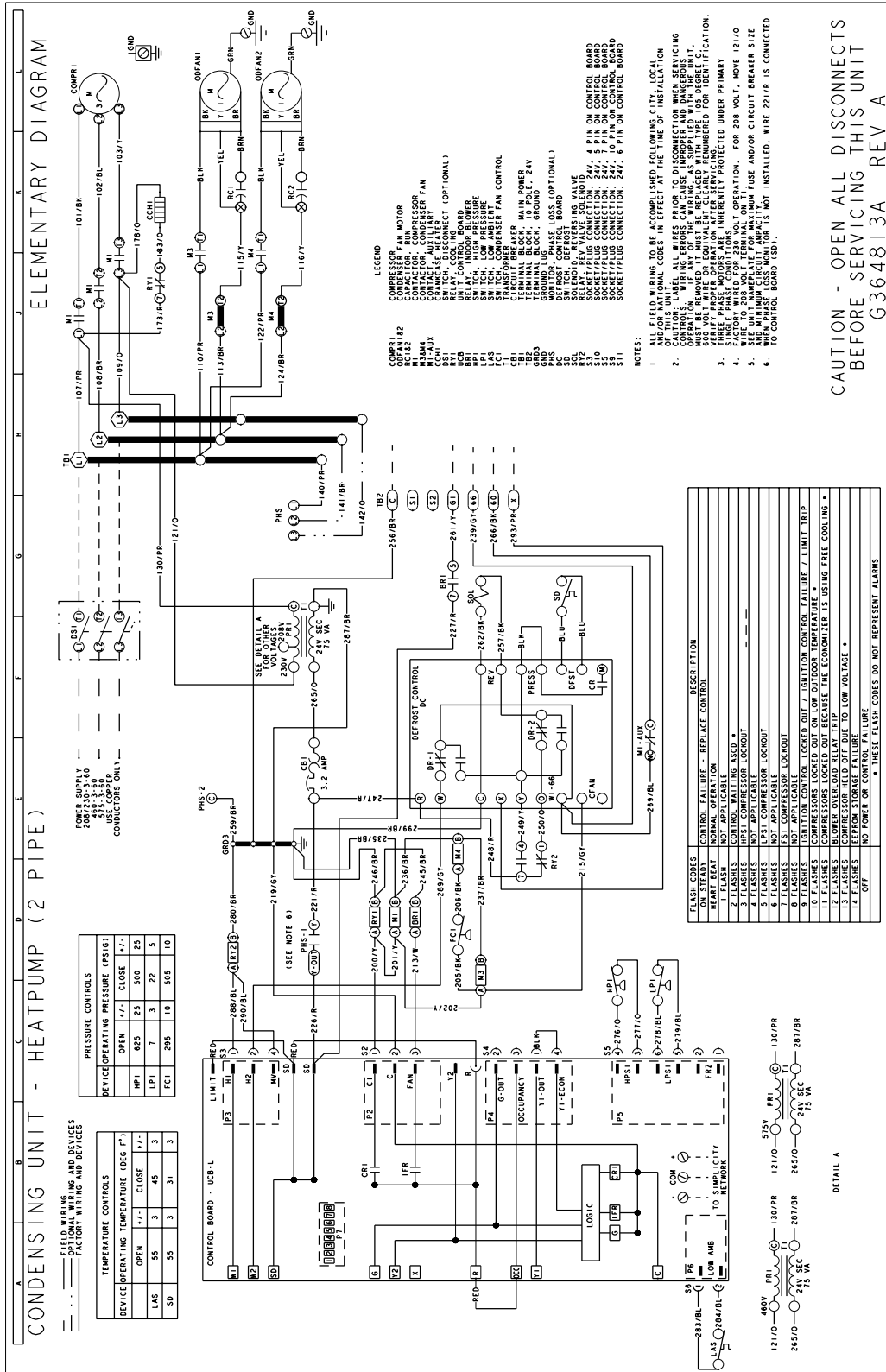

CAUTION - OPEN ALL DISCONNECTS BEFORE SERVICING THIS UNIT  
G364813A REV A









## Weights And Dimensions

### Corner Weights & Center of Gravity AC/HP Units

Model	Weight (lbs.)		Center of Gravity (in.)		4 Point Load Location (lbs.)			
	Shipping	Operating	X	Y	A	B	C	D
PC090	405	415	16	32.5	114	114	94	93
PC120	550	560	17.5	32.9	141	171	136	112
PC180	815	840	32.5	33	231	238	188	183
PD180	810	835	34	32.5	216	244	199	176
PC240	985	1010	31	32.5	287	269	220	235
PD240	980	1005	30.5	31.5	281	255	223	246
YC090	330	325	18.5	30.8	71	98	90	65
YC120	450	445	18	34	112	144	107	82
YD120	445	440	16.5	33.5	120	129	99	92
YC150	450	445	18	34	112	144	107	82
YD150	445	440	16.5	33.5	120	129	99	92
YC180	680	675	32.5	31.5	177	182	160	155
YD180	680	675	32.5	31.5	177	182	160	155
YC240	710	710	32	37	223	222	133	133
YD240	710	710	32	37	223	222	133	133

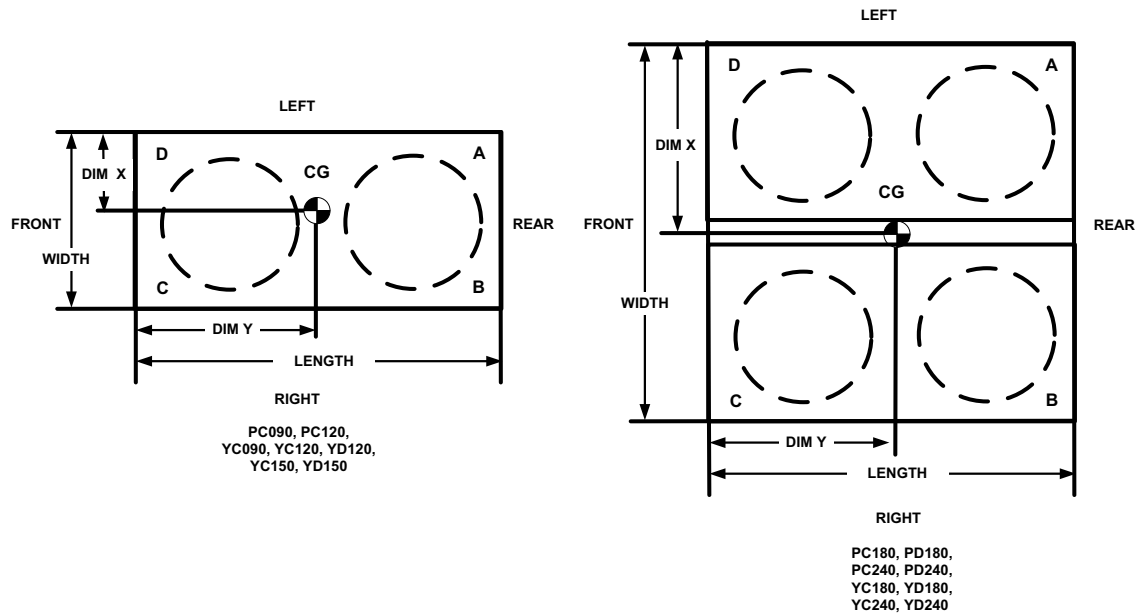

**NOTE:** Front of unit is considered the side having the unit control box.

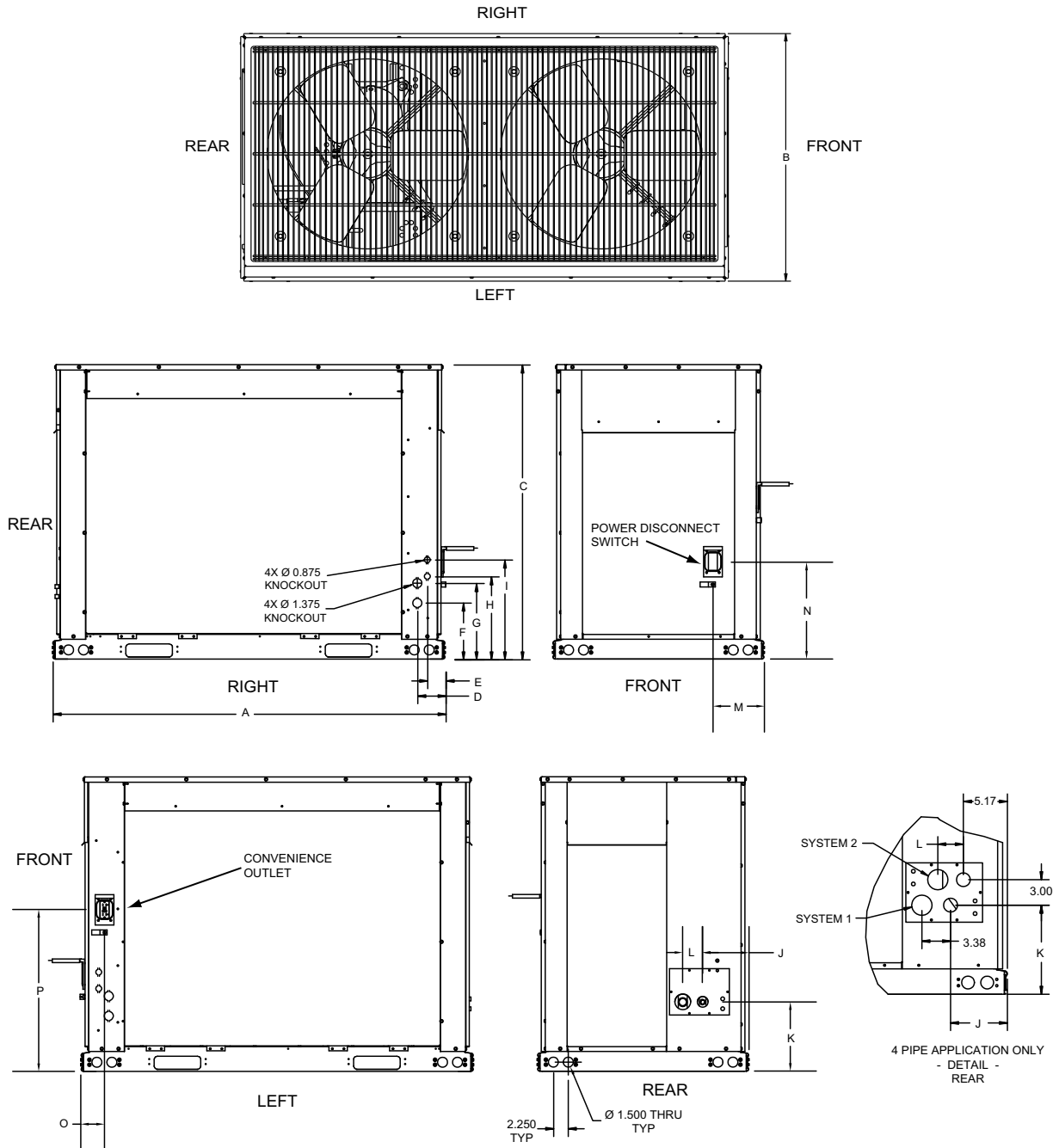

Unit Dimensions PC090, PC120, YC090, YC/YD120, YC/YD150

Unit Dimensions

MODEL	A	B	C	D	E	F	G	H	I	J	K	L	M	N	O	P
PC090	59.1	31.9	44.5	4.2	2.7	8.5	11.4	12.4	14.9	6.9	10.5	3.0	7.7	14.7	3.3	24.5
PC120	59.1	31.9	50.0	4.2	2.7	8.5	11.4	12.4	14.9	6.9	10.5	3.0	7.7	14.7	3.3	24.5
YC090	59.1	31.9	44.5	4.2	2.7	8.5	11.4	12.4	14.9	6.9	10.5	3.0	7.7	14.7	3.3	24.5
YC120	59.1	31.9	50.0	4.2	2.7	8.5	11.4	12.4	14.9	6.9	10.5	3.0	7.7	14.7	3.3	24.5
YD120	59.1	31.9	50.0	4.2	2.7	8.5	11.4	12.4	14.9	6.9	10.5	3.0	7.7	14.7	3.3	24.5
YC150	59.1	31.9	50.0	4.2	2.7	8.5	11.4	12.4	14.9	6.9	10.5	3.0	7.7	14.7	3.3	24.5
YD150	59.1	31.9	50.0	4.2	2.7	8.5	11.4	12.4	14.9	6.9	10.5	3.0	7.7	14.7	3.3	24.5

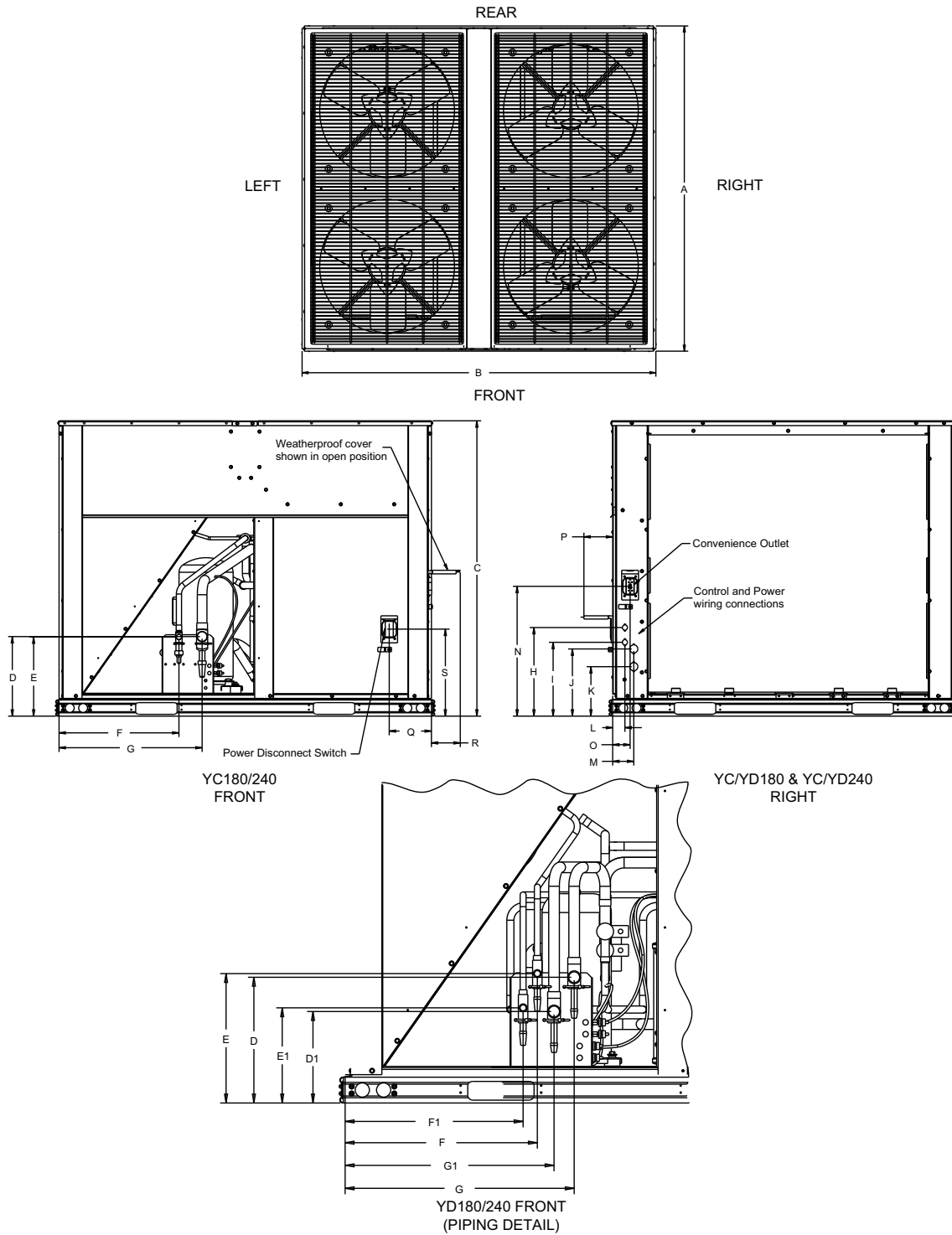

**Unit Dimensions PC/PD180, PC/PD240, YC/YD180, YC/YD240**

## Unit Dimensions

MODEL	A	B	C	D	DI	E	EI	F	FI	G	GI	H	I	J	K	L	M	N	O	P	Q	R	S
PC180	59.1	64.1	44.5	13.8	N/A	13.4	N/A	20.2	N/A	23.9	N/A	15.0	12.5	11.4	8.4	2.4	3.9	22.0	2.9	4.9	7.1	4.8	14.7
PD180	59.1	64.1	44.5	13.7	10.1	13.3	9.7	10.3	18.8	24.2	22.0	15.0	12.5	11.4	8.4	2.1	3.6	22.0	2.9	4.9	7.1	4.8	14.7
PC240	59.1	64.1	50.0	13.8	N/A	13.4	N/A	20.2	N/A	23.9	N/A	15.0	12.5	11.4	8.4	2.1	3.6	22.0	2.9	4.9	7.1	4.8	14.7
PD240	59.1	64.1	50.0	14.0	10.5	13.5	9.9	20.3	18.8	24.1	22.0	15.0	12.5	11.4	8.4	2.1	3.6	22.0	2.9	4.9	7.1	4.8	14.7
YC180	59.1	64.1	44.5	13.4	N/A	13.4	N/A	20.2	N/A	24.1	N/A	15.0	12.5	11.4	8.4	2.1	3.6	22.0	2.9	4.9	7.1	4.8	14.7
YD180	59.1	64.1	44.5	13.1	9.6	12.9	9.4	20.2	18.7	24.2	22.0	15.0	12.5	11.4	8.4	2.1	3.6	22.0	2.9	4.9	7.1	4.8	14.7
YC240	59.1	64.1	50.0	13.5	N/A	13.4	N/A	20.2	N/A	24.2	N/A	15.0	12.5	11.4	8.4	2.1	3.6	22.0	2.9	4.9	7.1	4.8	14.7
YD240	59.1	64.1	50.0	13.1	9.6	12.9	9.4	20.2	18.7	24.2	22.0	15.0	12.5	11.4	8.4	2.1	3.6	22.0	2.9	4.9	7.1	4.8	14.7

NOTE: The 'I' designation indicates a four pipe system.

## PIPING AND ELECTRICAL CONNECTIONS

Piping connections are made from the rear of 7.5 thru 12.5 Ton units and the front of 15 thru 20 Ton units. Connections can be made directly to the suction and liquid line service valves.

With the piping connections being made at the rear of 7.5 thru 12.5 Ton units and the front of 15 thru 20 Ton units, the piping can be routed to the units from the left or right side.

Electrical connections for power and control wiring are made from the front of the units, right or left of 7.5 thru 12.5 Ton electrical control box access or left of the electrical control box access on 15 thru 20 Ton units. See Unit Dimensions

and Piping and Electrical Connection Sizes tables for piping sizes and electrical knockout details.

## UNIT CLEARANCES

Location	Dimensions
Overhead (Top) <sup>1</sup>	120"
Front access panels	36"
Left Side	30"
Right Side	30"
Rear	24"
Bottom <sup>2</sup>	0"

<sup>1</sup> Units must be installed outdoors. Overhanging structures or shrubs should not obstruct condenser air discharge.

## Piping And Electrical Connection Sizes (Inches)

MODEL	PC090	YC090	PC120	YC120	YD120	YC150	YD150
No. Refrigeration Circuits	1	1	1	1	2	1	2
Suction Line OD (in.)	1 1/8	1 1/8	1 1/8	1 3/8	1 1/8	1 3/8	1 1/8
Liquid Line OD (in.)	5/8	5/8	5/8	7/8	5/8	7/8	5/8
Power Wiring Knockout	1 3/8	1 3/8	1 3/8	1 3/8	1 3/8	1 3/8	1 3/8
Control Wiring Knockout	7/8	7/8	7/8	7/8	7/8	7/8	7/8

MODEL	PC180	PD180	PC240	PD240	YC180	YD180	YC240	YD240
No. Refrigeration Circuits	1	2	1	2	1	2	1	2
Suction Line OD (in.)	1 5/8	1 1/8	1 5/8	1 3/8	1 5/8	1 1/8	1 5/8	1 3/8
Liquid Line OD (in.)	7/8	5/8	7/8	7/8	7/8	5/8	7/8	7/8
Power Wiring Knockout	1 3/8	1 3/8	1 3/8	1 3/8	1 3/8	1 3/8	1 3/8	1 3/8
Control Wiring Knockout	7/8	7/8	7/8	7/8	7/8	7/8	7/8	7/8

Subject to change without notice. Printed in U.S.A.  
Copyright © 2009 by Johnson Controls, Inc. All rights reserved.

505428-YTG-C-0309  
Supersedes: 505428-YTG-B-0209

---

**Johnson Controls Unitary Products**  
**5005 York Drive**  
**Norman, OK 73069**