

# Tranquility® Vertical Stack (TSM) Series

## Submittal Data

Models TSM09-36, 60Hz - HFC-410A



LC994

Rev.: March 24, 2022



# TSM Vertical Stack



	Introduction	4
	Features, Options and Accessories	5
	iGate® Advanced Communicating Controls	6
	Constant Volume (CV) – ECM	7
	vFlow® Modulating Water Valve	8
	Selection Procedure	9
	TSM Series Nomenclature – Cabinet	11
	TSM Series Nomenclature – Chassis	14
	TSM Series Accessory Nomenclature	16
	Performance Data – AHRI/ASHRAE/ISO 13256-1	19
	Performance Data – Selection Notes	20
	Performance Data – TSM09 with PSC Motor	21
	Performance Data – TSM12 with PSC Motor	22
	Performance Data – TSM15 with PSC Motor	23
	Performance Data – TSM18 with PSC Motor	24
	Performance Data – TSM24 with PSC Motor	25
	Performance Data – TSM30 with PSC Motor	26
	Performance Data – TSM36 with PSC Motor	27
	Performance Data – TSM09 with ECM Motor	28
	Performance Data – TSM12 with ECM Motor	29
	Performance Data – TSM15 with ECM Motor	30
	Performance Data – TSM18 with ECM Motor	31
	Performance Data – TSM24 with ECM Motor	32
	Performance Data – TSM30 with ECM Motor	33
	Performance Data – TSM36 with ECM Motor	34
	Air Flow Correction Table and Water Pressure Drop Adders	35
	Antifreeze Correction Table	36
	Performance Data – Correction Tables	38
	Blower Performance Data – TSM09 (PSC/ ECM-CT/ECM-CV)	39
	Blower Performance Data – TSM12 (PSC/ ECM-CT/ECM-CV)	40
	Blower Performance Data – TSM15 (PSC/ ECM-CT/ECM-CV)	41
	Blower Performance Data – TSM18 (PSC/ ECM-CT/ECM-CV)	42
	Blower Performance Data – TSM24 (PSC/ ECM-CT/ECM-CV)	43
	Blower Performance Data – TSM30 (PSC/ ECM-CT/ECM-CV)	44
	Blower Performance Data – TSM36 (PSC/ ECM-CT/ECM-CV)	45
	ECM-CV Blower Performance Data	46

Document page number is shown next to part number (e.g. LC994 - 3 = page 3). Since not all pages are typically used in the submittals process, the page number in the lower right corner can still be used (page \_\_\_\_ of \_\_\_\_).

ClimateMaster works continually to improve its products. As a result, the design and specifications of each product at the time of order may be changed without notice and may not be as described herein. Please contact ClimateMaster's Customer Service Department at 1-405-745-6000 for specific information on the current design and specifications. Statements and other information contained herein are not express warranties and do not form the basis of any bargain between the parties, but are merely ClimateMaster's opinion or commendation of its products. The latest version of this document is available at [climatemaster.com](http://climatemaster.com). © ClimateMaster, Inc. All rights reserved 2013

# TSM Vertical Stack

	Physical Data	47
Electrical Data - PSC Low Static Motor (208/230V) and (265V)		48
Electrical Data - ECM-CV Motor (208/230V) and (265V)		49
Electrical Data - ECM-CT Motor (208/230V) and (265V)		50
Typical Unit - Exploded View		51
TSM – Standard Unit, Furred In Cabinet with Risers		52
TSM – Leader Unit, Furred In Cabinet		53
TSM – Follower Unit, Furred In Cabinet, No Risers		54
Leader/Follower Cabinet		55
Cabinet Dimensions		56
Cabinet Slot Dimensions and Riser Arrangements		57
TSM Cabinet Configurations		58
Typical Cabinet w/”G” Panel Installation		59
Typical Recessed Cabinet w/”G” Panel and Frame Installation		60
Hinged “G” Style Return Air Panel – AVHSG Series		61
“L” Style (Flush Mounted) Return Air Panel – AVHRL Series		62
Hose Kits and Stands		63
Supply Air Openings and Grilles		64
Thermostats		66
TSM Cabinet Options		68
Riser Definitions		69
Riser GPM Definitions and Sizing		70
Riser Diameter Sizing		71
Swage Riser Length Definitions and Sizing		72
Swage Riser Extension Definitions and Sizing		73
Setting Cabinet		74
Slab Slot Chart - 3 Pipe		75
Shipping		76
Engineering Specifications		78
Pre-Engineered Factory Design Specials		91
Performance Sheet		92
Revision History		93



## TRANQUILITY® VERTICAL STACK (TSM) SERIES WITH EARTHPURE® REFRIGERANT

---

The Tranquility® Vertical Stack (TSM) Series offers an innovative, labor-saving solution for spaces where individual, quiet control of the heating and cooling systems is important. Vertical stack products are designed for multi-story buildings where floor to floor footprints are similar. They utilize vertically mounted water lines known as risers installed in a wall or mechanical shaft to minimize space, material, and connections. The TSM system consists of two major components – a cabinet located behind a finished wall and a slide in and out refrigeration chassis. This allows for the riser and cabinet pieces of the system to be installed early in the construction phase so they can be framed around without exposing the refrigeration chassis to the harsh construction environment. At the finishing stages of construction when the system is ready to be commissioned, the slide in chassis is quickly and easily installed. The TSM system offers a proven solution that is designed and manufactured in America, exceeds ASHRAE 90.1 efficiencies, contractor/technician friendly, has a compact foot print minimizing its impact on salable space, maximizes comfort levels of occupants, and has been proven as a preferred system in thousands of multi-story building applications across North America.

The TSM series is available in seven sizes ranging from 3/4 ton (2.6 kW) through 3 tons (10.6 kW). The cabinet has been designed with flexibility offering five different supply air locations and four different riser connection locations that can be factory or field configured. The chassis is designed for quick installation with two water hose connections and three or four electrical quick connectors. Both pieces of the system offer options to increase a buildings energy efficiency. Integrated water control options save system watts by preventing over pumping both when the unit is in operation and when its not. ECM fan motors maximize the systems airflow movement efficiency. Industry exclusive advanced communicating controls offer reduced start-up and commissioning time by providing an easy to read gateway into the systems operating conditions.

High-end condos/apartments/hotels demand the highest level of occupant comfort. Not only is it important for the system to provide heating, cooling, and dehumidification it must do so at quiet operating levels. ClimateMaster's double isolation compressor mounting system makes the TSM Series the quietest vertical stack unit on the market. Compressors are mounted on specially engineered sound-tested isolation grommets to a heavy gauge base pan, which

is then isolated from the cabinet base with a second layer of grommets under the condensate pan to provide superior sound attenuation by design. ClimateMaster offers an Ultra-Quiet sound attenuation package and cabinet isolation pad to meet the demand of the most sound sensitive applications.

iGate® technology provides technicians an interface into the operation of the system in real time without the need for hard tooling. On board advanced controls communicate the key operating temperatures allowing technicians to start-up, commission, and service the equipment through a hand-held service tool which is easily connected without removing any unit hardware. Not only does iGate monitor current performance, it also offers the functionality to make system adjustments and captures operating conditions in the event of a system safety shut down. All this information is displayed in an easy to read format improving the usability of the experience.

vFlow® variable water flow technology takes water flow control and system operating range to the next level. The functionality of an on/off water valve and water flow regulator are combined into one modulating water valve component. With a modulating valve water flow is controlled to maintain a set temperature difference between entering and leaving water while in normal operation. When in extreme entering water conditions the vflow system switches its operation to maintain a leaving water temperature. With the functionality to control water flow to a leaving water temperature, the TSM's operational range is expanded beyond other water source heat pumps with an ability to function in heating or cooling modes across the entire entering water range of 30–120°F. While not in operation the valve remains closed preventing excessive water flow. vFlow increases system water flow efficiency by only allowing the right amount of water flow needed when it needs. Advanced iGate controls paired with the vFlow system provide functionality and efficiency unmatched in the marketplace.

The TSM Vertical Stack Water-Source Heat Pump Series provides energy efficiency with superior sound attenuation by design while offering options flexibility, field convertibility, and unmatched industry leading technology.

### New September 2020

- **Added Pre-Engineered Factory Design Specials Section**
- **3-way water valves**
- **New thermostat options**
- **Document update**
- **DDC chassis controls harness options**

# Features, Options and Accessories

## FEATURES

- Sizes 09 (3/4 ton, 2.6 kW) through 36 (3 ton, 10.6 kW)
- Environmentally-friendly EarthPure® (HFC-410A) zero ozone depletion refrigerant
- High efficiency rotary and scroll compressors
- Exceeds ASHRAE 90.1 efficiencies
- Removable chassis allows staged installation and ease of maintenance
- Coaxial heat exchanger
- Galvanized steel cabinet
- Chassis rests on rubber grommets isolated condensate pan for vibration reduction
- Double isolation of compressor for quiet operation
- TXV metering device
- Cabinet construction for unit or remote-mounted controls
- PSC fans capable of two speeds
- Microprocessor controls with 8 standard safeties
- Unit Performance Sentinel performance monitoring system
- Integrated drain pan with condensate overflow sensor
- Field convertible supply air on all sides and the top
- Field convertible riser supply, return, and condensate locations on the left, right, or back sides

## OPTIONS

- iGate® Advanced Communicating Controls
  - Provides real-time unit operating conditions
  - Reduces start-up and commissioning times by removing the need for hard tooling to take temperature measurements
  - Captures operating conditions in the event of a safety shutdown
  - Provides direct control over intelligent constant volume (CV) ECM fan motor and vFlow modulating water valve
  - Service tool is quickly connected without the need to remove any unit hardware
- vFlow® modulating water flow
  - Modulates water flow to maintain a water temperature differential
  - Changes operation to modulate to a leaving water temperature during extreme entering water temperatures
  - Provides ultimate variable water flow control
  - Functionally operates as both a water flow regulator and water close off valve
- 2" Filter Rail to support higher indoor air quality filters
- BACnet (MSTP), Modbus and Johnson N2 compatibility options for DDC controls
- Factory configured supply air openings with or without dust protection

- Full port shut-off valves with memory stop, for supply and return risers.
- Unit integrated power disconnect
- Field quick connect thermostat whips in 15', 25', and 35' lengths
- Factory mounted high density rubber isolation pad
- Easy to clean rust prohibitive stainless steel drain pans
- High efficient ECM fan motors
  - Intelligent Constant Volume (CV) ECM motors for ultimate airflow control
  - Entry level Constant Torque ECM motors that provide efficiency at a value
- Extended range insulation for geothermal applications
- Auto flow regulators that limit water flow to the unit preventing system over pumping
- Two-way motorized water valves that prevent water flow through the unit when it is not in operation increasing system pumping efficiency (fail open or fail closed options)
- Three-way motorized water valves that allow continuous water flow through the water loop, reducing pressure drop when the unit is not in operation (usually applied on the top floor of a system)
- Internally mounted water pump for single pipe systems
- Corrosive resistant cupro-nickel water heat exchanger
- RIB relay (sizes 09-18) box for quiet contactor closer
- UltraQuiet sound attenuation package
- Tin-lated air coils for added protection from formicary corrosion

## ACCESSORIES

- Copper risers
  - Swaged ends ready for quick drop in connection when brazing is used
  - End treatment ready for crimped (torch-less) style connections
- Unit stands that prevent clearance issues with tall baseboards
- Single, Double, and Double deflection with opposed dampers supply air grilles
- Fresh air frame kit for connection to outdoor air ducting
- Flush Mounted Return Air Panel (L Style) with fixed frame and removable panel for easy chassis access/removal
- Attractive return air panel with hinged access door (G style)
  - Key Lock Option
- Stainless steel braided hose kits for connection from piping risers to the chassis
- Selection of thermostats including programmable, Wi-Fi, and color touch screen
- Filters - 1" (Merv 8 or 11) or 2" (Merv 8 or 13)

# iGate® Advanced Communicating Controls

## iGate® - Information gateway to monitor, control, and diagnose your system

Tranquility® Vertical Stack (TSM) Series offers the industry's first 2-way communicating gateway that allows user to interact with the system in an easy to read and understandable format. The technology is designed to improve reliability and efficiency by precisely controlling variable speed components.

**Configure & Monitor** – Technicians have the ability to configure airflow, water temperature differential, unit options, and demand reduction. Users can view the systems status in real time through the use of sensor readings.

**Precise Control** – The new DXM2 board enables intelligent, 2-way communication between the DXM2 board and smart components like the communicating thermostat/service tool, CV ECM fan motor, and vFlow® modulating water valve. The DXM2 board uses information received from the smart components and sensors to precisely control unit operation as well as to deliver higher efficiency, quieter operation, reliability and increased comfort.

**Diagnostics** – iGate takes diagnosing water source heat pumps to a next level of simplicity, by providing a dashboard of system and fault information, in plain English, on the iGate thermostat or service tool. iGate Service Warning feature displays fault description, possible causes and current system status (temperature readings, fan RPM and water flow status) which may be reported to service personnel.

In iGate Service Mode, the service personnel can access fault description, possible causes and most importantly, the conditions (temp, flow, i/o conditions, configuration) at the time of the fault. Manual Operation mode allows the service personnel to manually command operation for any of the thermostat outputs, blower speed, as well as pump speed or valve position from the thermostat, to help troubleshoot specific components.

With iGate communicating controls, technicians have a gateway to system information never before available and exclusive to ClimateMaster vertical stack products.

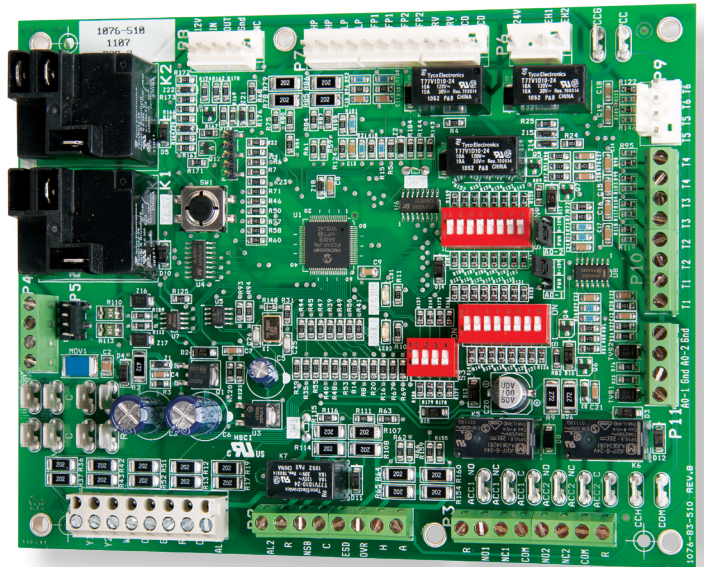

AIRFLOW SELECTION	
HEAT STAGE 1	CFM 600
HEAT STAGE 2	750
AUXILIARY HEAT	850
EMERGENCY HEAT	850
COOL STAGE 1	525
COOL STAGE 2	700
COOL DEHUMID 1	425
COOL DEHUMID 2	550
CONTINUOUS FAN	350
HEAT OFF DELAY	60
COOL OFF DELAY	30
◀ PREVIOUS	
NEXT ▶	

POSSIBLE FAULT CAUSES	
LOW WATER COIL TEMP	
LOW WATER TEMP - HTG	
LOW WATER FLOW - HTG	
LOW REFRIG CHARGE - HTG	
INCORRECT LT1 SETTING	
BAD LT1 THERMISTOR	
◀ PREVIOUS	

FAULT TEMPERATURE CONDITIONS	
LT1 LOW WATER TEMP	
HEAT 1 11:11 AM 11/14	
LT1 TEMP	28.1
LT2 TEMP	97.3
HOT WATER EWT	121.5
COMP DISCHARGE	157.7
LEAVING AIR	92.7
LEAVING WATER	34.9
ENTERING WATER	42.1
CONTROL VOLTAGE	26.4
◀ PREVIOUS	

ClimateMaster works continually to improve its products. As a result, the design and specifications of each product at the time of order may be changed without notice and may not be as described herein. Please contact ClimateMaster's Customer Service Department at 1-405-745-6000 for specific information on the current design and specifications. Statements and other information contained herein are not express warranties and do not form the basis of any bargain between the parties, but are merely ClimateMaster's opinion or commendation of its products. The latest version of this document is available at [climatemaster.com](http://climatemaster.com). © ClimateMaster, Inc. All rights reserved 2013

# Constant Volume (CV) – ECM

**The Intelligent Constant Volume (CV) ECM blower motor** provides unmatched functionality that saves installing and service technicians time while also providing increased comfort levels to occupants.

CV ECM's are programmed to maintain a constant CFM across a wide range of external static pressures (ESP). This functionality differs from traditional PSC or even Constant Torque (CT) ECM's. With tradition PSC and CT ECM fan motors as ESP is increased, CFM is reduced. To increase or decrease the speed of the fan motor requires a fan motor switch or a technician to wire into a different motor tap. CT ECM's provide increased efficiency over PSC motors but with no additional functionality. With a CV ECM as changes in ESP occur the fan motor will adjust its speed to deliver the desired CFM (within its operating range). This ensures the system is delivering the airflow and capacity it was designed for.

A major benefit of the CV ECM over other fan motor types its ability to adjust airflow through the iGate communication service tool or thermostat. Airflow levels can be adjusted in increments of 25 CFM from the units minimum and maximum CFM range (see ECM-CV configuration table for details). This functionality allows technicians to dial in airflow during start-up and commissioning via an easy to use service tool. The service tool is connected to the unit without the removal of any hardware making it easy to get to by simply opening the return air panel. During operation occupants may have a desire for airflow adjustments. Reducing CFM can reduce airflow sound levels and increase cooling dehumidification (latent capacity). Technicians can easily make these adjustments without the need to remove unit hardware or make wiring changes reducing service time with minimal disruption to the occupants.

The fan motor operating modes include:

- First Stage Cooling (Y1 & O)
- Second Stage Cooling (Y1, Y2, & O)
- First Stage Heating (Y1)
- Second Stage Heating (Y1 & Y2)
- Fan (G with no Y1, Y2, or W)

The CV ECM motor includes “soft start” and “ramp down” features. The soft start feature gently increases the motors rpm at blower start up resulting quieter blower start cycles. Likewise, the ramp down feature allows the blower to slowly decrease rpm to a full stop resulting in a quieter end to each blower cycle. The ramp down feature (also known as the heating or cooling “Off Delay”) also has the functionality to be field selected by the technician in the allowable range of 0 to 255 seconds.

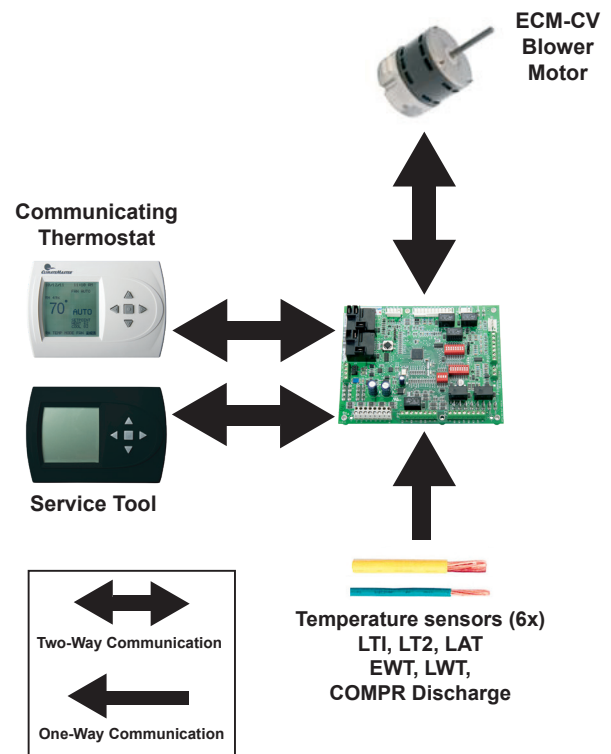

AIRFLOW SELECTION	
	CFM
HEAT STAGE 1	600
HEAT STAGE 2	750
AUXILIARY HEAT	850
EMERGENCY HEAT	850
COOL STAGE 1	525
COOL STAGE 2	700
COOL DEHUMID 1	425
COOL DEHUMID 2	550
CONTINUOUS FAN	350
HEAT OFF DELAY	60
COOL OFF DELAY	30
◀ PREVIOUS	NEXT ▶

**Airflow Configuration Screen on Communicating Thermostat or Service Tool**

# vFlow® Modulating Water Valve

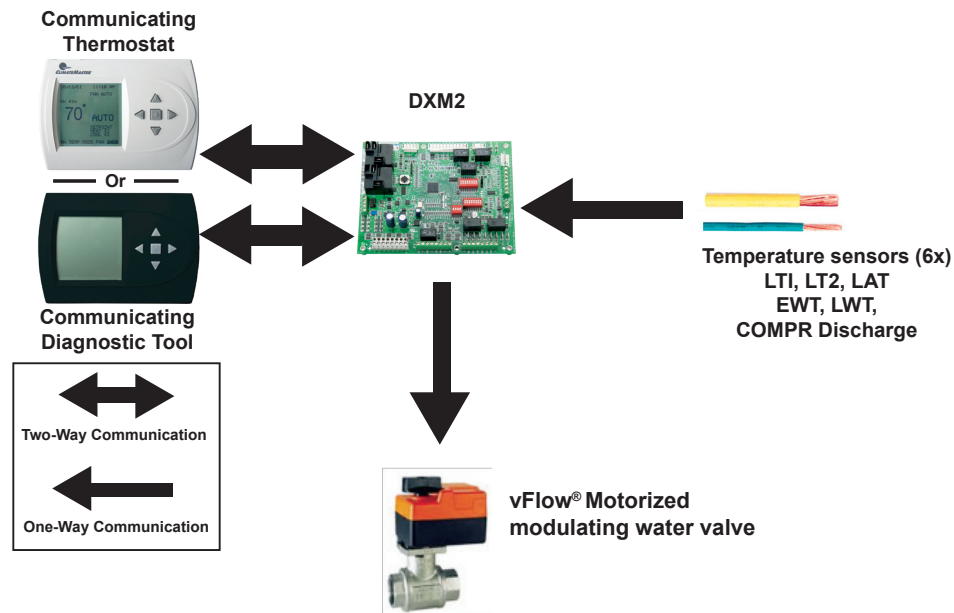

## vFlow® Internal Variable Water Flow

Industry-first, Built-in vFlow® provides an ultra-high-efficient internal water flow system. It saves installers time and labor by avoiding installing bulky valves or flow regulators in the field. Multi-unit installations are also much simpler with vFlow systems, as the units automatically adjust water flow across the system.

vFlow is enabled by iGate®, which facilitates intelligent communication between the thermostat, DXM2 control, sensors and modulating valve to make true variable water flow a reality.

In applications using the vFlow water flow control, when the motorized modulating valve slows down the external pump, consumes fewer watts, thus saving more energy.

## vFlow® delivers four main benefits:

1. One component replaces 2 way motorized valve and auto flow regulator
2. Superior reliability by varying the water flow to deliver more stable operation
3. Higher cost savings by varying water flow (and pump watt consumption) to match the unit's mode of operation
4. Allows unit to safely operate in cooling mode or heating mode from 20°F to 120°F

## Modulating Water Valve Operation:

When the unit is in cooling or heating, the DXM2 controller monitors the entering and leaving water temperature. Based on the desired water temperature differential (delta T), the DXM2 sends a voltage signal to the valve which correlates to a percentage open in order to achieve the water flow needed. As conditions change the voltage signal will readjust the valve for the needed water flow.

The modulating water valve is factory set for a water delta T of 10F for cooling operation and 7F for heating operation. This default setting is estimated to be approximately 3 GPM of water flow per ton of load capacity. Installers can change the water flow by adjusting the delta T upward for lower flow or downward for higher flow by using the communicating thermostat or service tool. Please see unit IOM for full instructions.

At low cooling EWT's and high heating EWT's the DXM2 software overrides the delta T settings and adjusts the valve to operate to a LWT of no less than 60F for cooling and no greater than 70F for heating.

Units with the modulating water valve will operate at EWT's from 30°F to 120°F in BOTH cooling and heating. When there is no demand for cooling or heating, the valve will be fully closed or can be field configured to remain slightly open allowing some water to pass through.

vFlow water flow controls are unmatched in the market and exclusive to ClimateMaster vertical stack products.



# Selection Procedure

## Reference Calculations

Heating	Cooling	
$LWT = EWT - \frac{HE}{GPM \times \text{Constant}}$	$LWT = EWT + \frac{HR}{GPM \times \text{Constant}}$	$LC = TC - SC$
$LAT = EAT + \frac{HC}{CFM \times 1.08}$	$LAT (DB) = EAT (DB) - \frac{SC}{CFM \times 1.08}$	$S/T = \frac{SC}{TC}$

Constant = 500 for water, 485 for antifreeze.

## Legend and Glossary of Abbreviations

BTUH = BTU (British Thermal Unit) per hour	GPM = water flow in U.S. gallons/minute
MBTUH = 1,000 BTU per hour	WPD = waterside pressure drop (psi & ft. of hd.)
TC = total cooling capacity, BTUH	HE = total heat of extraction, BTUH
SC = sensible cooling capacity, BTUH	HR = total heat of rejection, BTUH
S/T = sensible to total cooling ratio	KW = total power unit input, kilowatts
LC = latent cooling capacity, BTUH	EER = energy efficient ratio = BTUH output/Watt input
HC = air heating capacity, BTUH	COP = coefficient of performance = BTUH output/BTUH input
CFM = airflow, cubic feet/minute	MPT = male pipe thread
ESP = external static pressure (inches w.g.)	FPT = female pipe thread
EAT = entering air temperature	HWC = hot water generator (desuperheater) capacity, Mbtuh
LAT = leaving air temperature, °F	ECM-CV = electronic commutated constant volume fan motor
DB = dry bulb temperature (°F)	ECM-CT = electronic commutated constant torque fan motor
WB = wet bulb temperature (°F)	MWV = motorized water valve
EWT = entering water temperature	WSE = waterside economizer
LWT = leaving water temperature, °F	VFD = variable frequency drive
TD or delta T = temperature differential	

## Conversion Table - to convert inch-pound (English) to S-I (Metric)

Air Flow	Water Flow	Est Static Pressure	Water Pressure Drop
Airflow (L/s) = CFM x 0.472	Water Flow (L/s) = gpm x 0.0631	ESP (Pa) = ESP (in of wg) x 249	PD (kPa) = PD (ft of hd) x 2.99

# Selection Procedure

- Step 1** Determine the actual heating and cooling loads at the desired dry bulb and wet bulb conditions.
- Step 2** Obtain the following design parameters: Entering water temperature, water flow rate in GPM, air flow in CFM, water flow pressure drop and design wet and dry bulb temperatures. Air flow CFM should be between 300 and 500 CFM per ton. Unit water pressure drop should be kept as close as possible to each other to make water balancing easier. Go to the appropriate tables and find the proper indicated water flow and water temperature.
- Step 3** Select a unit based on total and sensible cooling conditions. Select a unit which is closest to, but no larger than, the actual cooling load.
- Step 4** Enter tables at the design water flow and water temperature. Read the total and sensible cooling capacities (Note: interpolation is permissible, extrapolation is not).
- Step 5** Read the heating capacity. If it exceeds the design criteria it is acceptable. It is quite normal for Water-Source Heat Pumps to be selected on cooling capacity only since the heating output is usually greater than the cooling capacity.
- Step 6** Determine the correction factors associated with the variable factors of dry bulb, wet bulb, and air flow.  
  

$$\text{Corrected Total Cooling} = \text{tabulated total cooling} \times \text{wet bulb correction} \times \text{air flow correction.}$$

$$\text{Corrected Sensible Cooling} = \text{tabulated sensible cooling} \times \text{wet/dry bulb correction, and air flow correction.}$$
- Step 7** Compare the corrected capacities to the load requirements. Normally if the capacities are within 10% of the loads, the equipment is acceptable. It is better to under size than oversize, as undersizing improves humidity control, reduces sound levels and extends the life of the equipment.
- Step 8** When completed, calculate water temperature rise and assess the selection. If the units selected are not within 10% of the load calculations, then review what effect changing the GPM, water temperature and/or air flow and air temperature would have on the corrected capacities. If the desired capacity cannot be achieved, select the next larger or smaller unit and repeat the procedure. Remember, when in doubt, under size slightly for best performance.

## Example Equipment Selection For Cooling Step 1 Load Determination:

Assume we have determined that the appropriate cooling load at the desired dry bulb 80°F and wet bulb 65°F conditions is as follows

Total Cooling .....17,000 BTUH  
 Sensible Cooling.....12,000 BTUH  
 Entering Air Temp..... 80°F Dry Bulb / 65°F Wet Bulb

## Step 2 Design Conditions:

Similarly, we have also obtained the following design parameters:

Entering Water Temp ..... 90°F  
 Water Flow (Based upon 10°F rise in temp.)..... 5.1 GPM  
 Air Flow at ESP Unit ..... 630 CFM (90% of rated)

## Steps 3, 4 & 5 HP Selection:

After making our preliminary selection (TSM18 with PSC motor), we enter the tables at design water flow and water temperature and read Total Cooling, Sens. Cooling and Heat of Rej. capacities:

Total Cooling ..... 18,350 BTUH  
 Sensible Cooling.....13,210 BTUH  
 Heat of Rejection.....22,470 BTUH

## Steps 6 & 7 Entering Air and Airflow Corrections:

Next, we determine our correction factors.

Table   Ent Air   Air Flow   Corrected

Corrected Total Cooling = 18,350 × 0.975 × 0.971 = 17,372  
 Corrected Sens Cooling = 13,210 × 0.999 × 0.932 = 12,299  
 Corrected Heat of Reject = 22,470 × 0.982 × 0.979 = 21,602

## Step 8 Water Temperature Rise Calculation and Assessment:

Actual Temperature Rise.....8.8°F

When we compare the Corrected Total Cooling and Corrected Sensible Cooling figures with our load requirements stated in Step 1, we discover that our selection is within +/- 10% of our sensible load requirement. Furthermore, we see that our Corrected Total Cooling figure is slightly undersized as recommended, when compared to the actual indicated load.

# TSM Series Nomenclature – Cabinet

Section	Position	Digit Value	Description
<b>Series</b>	1	C	Non-Ducted Cabinet Series
<b>Size</b>	2	1	09 - 0.75 ton
		2	12 - 1 ton
		3	15 - 1.25 ton
		4	18 - 1.5 ton
		5	24 - 2 ton
		6	30 - 2.5 ton
		7	36 - 3 ton
<b>Voltage</b>	3	G	208/230/60/1
		E	265/60/1
<b>Options</b>	4	A	Premium Seal
		B	Stainless Steel Drain Pan
		C	Premium Seal & Stainless Steel Drain Pan
		0	None
		1	Premium Seal & 2" Filter
		2	Stainless Steel Drain Pan & 2" Filter
		3	Premium Seal, Stainless Steel Drain Pan, & 2" Filter
		4	2" Filter
<b>Harness Controls</b>	5	A	PSC fan motor, ADA mounted
		B	CV ECM fan motor, ADA mounted
		C	PSC fan motor, MPC DDC controls
		D	CV ECM fan motor, MPC DDC controls
		L	PSC fan motor
		M	CV ECM fan motor
		N	PSC fan motor, Remote mounted thermostat
		P	PSC fan motor, Cabinet mounted thermostat
		R	CV ECM fan motor, Remote mounted thermostat
		S	CV ECM fan motor, Cabinet mounted thermostat
		1	CT ECM fan motor, ADA mounted
		2	CT ECM fan motor, MPC DDC controls
		3	CT ECM fan motor
		4	CT ECM fan motor, Remote mounted thermostat
		5	CT ECM fan motor, Cabinet mounted thermostat
<b>Power Termination</b>	6	A	Disconnect switch
		B	Breaker
		C	Breaker, Internal circulating pump
		D	Disconnect switch, Internal circulating pump
		E	Internal circulating pump
		0	None
		<b>Cabinet Height</b>	7
B	80"		
C	88" with isolation pad		
D	80" with isolation pad		

**Table Continue on Next Page**

# TSM Series Nomenclature –Cabinet

Table Continue from Previous Page

Section	Position	Digit Value	Description
<b>Riser Style</b>	8	0	Follower/None
		1	Standard
		2	Leader
<b>Riser Location</b>	9	0	None
		1	Shipped Separately
		2	Left Back
		3	Right Back
		4	Left Side
		5	Right Side
		6	Chassis shipped in cabinet, risers shipped separately
<b>Riser Ball Valve Options</b>	10	5	Standard (MNPT) Ball Valves
		N	None
<b>Back/Front/Top Supply Air Locations</b>	11	0	None
		A	Back Small
		B	Back Large
		C	Front Small
		D	Front Large
		E	Top
		F	Back Small & Top
		G	Back Large & Top
		H	Front Small & Top
		J	Front Large & Top
		K	Back Small & Front Small
		L	Back Large & Front Large
		M	Back Small & Front Large
		N	Back Large & Front Small
		P	Back Small, Front Small, & Top
		Q	Back Large, Front Large, & Top
		R	Back Small, Front Large, & Top
S	Back Large, Front Small, & Top		
<b>Side Supply Air Locations</b>	12	0	None
		A	Right Small
		B	Right Large
		C	Left Small
		D	Left Large
		E	Right Small & Left Small
		F	Right Large & Left Large
		G	Right Small & Left Large
H	Right Large & Left Small		

Table Continue on Next Page

# TSM Series Nomenclature – Cabinet

Table Continue from Previous Page

Section	Digit Position Value	Description	Option	Thermostat Whip	SA Opening	SA Dust Cover	RA Dust Cover
<b>Misc. Cabinet Options</b>	13		<b>A</b>	No Tstat Whip	Factory Configured	Yes	Yes
			<b>B</b>	15' Tstat Whip			
			<b>C</b>	25' Tstat Whip			
			<b>D</b>	35' Tstat Whip			
			<b>E</b>	No Tstat Whip	Field Configured	None	Yes
			<b>F</b>	15' Tstat Whip			
			<b>G</b>	25' Tstat Whip			
			<b>H</b>	35' Tstat Whip			
			<b>J</b>	No Tstat Whip	Factory Configured	Yes	None
			<b>K</b>	15' Tstat Whip			
			<b>L</b>	25' Tstat Whip			
			<b>M</b>	35' Tstat Whip			
			<b>N</b>	No Tstat Whip	Factory Configured	None	Yes
			<b>P</b>	15' Tstat Whip			
			<b>Q</b>	25' Tstat Whip			
			<b>R</b>	35' Tstat Whip			
			<b>0</b>	No Tstat Whip	Field Configured	None	None
			<b>1</b>	15' Tstat Whip			
			<b>2</b>	25' Tstat Whip			
			<b>3</b>	35' Tstat Whip			
			<b>4</b>	No Tstat Whip	Factory Configured	None	None
	<b>5</b>	15' Tstat Whip					
	<b>6</b>	25' Tstat Whip					
	<b>7</b>	35' Tstat Whip					
<b>Type</b>	14	0	Standard				
<b>Revision</b>	15	D	Non-Ducted & Ducted Cabinet Series				

# TSM Series Nomenclature – Chassis

Section	Position	Digit Value	Description
<b>Series</b>	1-3	TSM	Vertical Stack Non-Ducted Applications
<b>Unit Size</b>	4-5	09	09 - 0.75 ton
		12	12 - 1 ton
		15	15 - 1.25 ton
		18	18 - 1.5 ton
		24	24 - 2 ton
		30	30 - 2.5 ton
<b>Voltage</b>	6	E	265/60/1
		G	208-230/60/1
<b>Chassis Options</b>	7	A	Stainless Steel Drain Pan
		B	Ultra Quiet
		C	Stainless Steel Drain Pan & Ultra Quiet
		D	Stainless Steel Drain Pan & Connection to communicating thermostat
		E	Ultra Quiet & Connection to communicating thermostat
		F	Stainless Steel Drain Pan, Ultra Quiet, & Connection to communicating thermostat
		G	Connection to communicating thermostat
		H	Stainless Steel Drain Pan & RIB Relay
		K	Ultra Quiet & RIB Relay
		L	Stainless Steel Drain Pan, Ultra Quiet, & RIB Relay
		M	RIB Relay
		N	Stainless Steel Drain Pan, RIB Relay, & Connection to communicating thermostat
		P	Ultra Quiet, RIB Relay, & Connection to communicating thermostat
Q	Stainless Steel Drain Pan, Ultra Quiet, RIB Relay, & Connection to communicating thermostat		
R	RIB Relay & Connection to communicating thermostat		
S	None		
<b>Controls</b>	8	A	CXM
		B	DXM2
		C	CXM w/MPC
		D	DXM2 w/MPC
<b>Auto-Flow Regulator</b>	9	C	1.5 GPM
		D	2 GPM
		E	2.5 GPM
		F	3 GPM
		G	3.5 GPM
		H	4 GPM
		J	5 GPM
		K	6 GPM
		L	7 GPM
		M	8 GPM
		N	9 GPM
		P	10.5 GPM
		S	None

Table Continue on Next Page

# TSM Series Nomenclature –Chassis

Table Continue from Previous Page

Section	Position	Digit Value	Description
<b>Water Circuit Options</b>	10	S	None
		M	2-Way Water Valve - Fail Closed
		N	2-Way Water Valve - Fail Opened
		G	3-Way Water Valve
		T	Modulating Water Valve
		P	Secondary Circulating Pump
<b>Heat Exchanger Options</b>	11	C	Tin-Plated Air Coil & Copper Water Coil
		N	Tin-Plated Air Coil & Cupro-Nickel Water Coil
		D	Tin-Plated Air Coil, Copper Water Coil, & Insulated Tubing
		E	Tin-Plated Air Coil, Cupro-Nickel Coil, & Insulated Tubing
		F	Standard Air Coil, Copper Water Coil, & Insulated Tubing
		G	Standard Air Coil, Cupro-Nickel Coil, & Insulated Tubing
<b>Heat Exchanger Options</b>	11	L	Standard Air Coil & Copper Water Coil
		M	Standard Air Coil, Cupro-Nickel Coil
<b>Shipping</b>	12	6	Chassis Ships in Cabinet (risers not attached)
		S	Standard
<b>Blower Motor</b>	13	B	PSC - Low Static (TSM Only)
		C	ECM - Constant Torque
		D	ECM - Constant Volume
<b>Standard</b>	14	S	Standard

# TSM Series Accessory Nomenclature

## Return Air Panel "G" Style

1 2 3 4 5 6 7 8 9 10 11

**AVHS G 1 S F S N S**

**ACCESSORY VHS RETURN AIR PANEL**

TYPE	DESCRIPTION
"G"	Removable

UNIT WIDTH	
OPTION	WIDTH
1	17"
2	19"
3	24"

**COLOR**  
S = STANDARD (POLAR ICE)  
W = BRIGHT WHITE

**INSULATION TYPE**  
F = FIBERGLASS

**STANDARD**  
S = STANDARD

**REVISION LEVEL**  
N = CURRENT REVISION TSM/TSL ("G" PANEL)

**STYLE**  
A = DOOR w/ADA TYPE 1 TSTAT OPTION  
B = DOOR w/ADA TYPE 2 TSTAT OPTION  
C = DOOR w/ADA TYPE 1 TSTAT OPTION & LOCK  
D = DOOR w/ADA TYPE 2 TSTAT OPTION & LOCK  
L = DOOR w/KEY LOCKS  
S = STANDARD DOOR

THERMOSTAT MOUNTING	
TYPE 1	TYPE 2
ATP21W02	AVB32V02C
ATA11U03	ATA32V01
ATC32U03C	
ATA11U01	
ABV32V03C	

## Return Air Panel "L" Style

1 2 3 4 5 6 7 8 9 10 11 12 13

**AVHRL 1 S F S F 0 A S**

**ACCESSORY VS RETURN AIR PANEL**  
AVHRL = L-PANEL

UNIT WIDTH		
OPTION	WIDTH	TSM/TSL
1	17"	09 - 12,
2	19"	15, 18
3	24"	24
4	24"	30 - 36

**COLOR**  
S = STANDARD (POLAR ICE)  
W = BRIGHT WHITE

**INSULATION TYPE**  
F = FIBERGLASS

**STANDARD**  
S = STANDARD

**REVISION LEVEL**  
A = CURRENT REVISION

**RESERVED FOR FUTURE USE**  
0 = STANDARD

**COMPONENT**  
F = FRAME  
P = PANEL

**STYLE**  
S = STANDARD



# TSM Series Accessory Nomenclature

## Riser

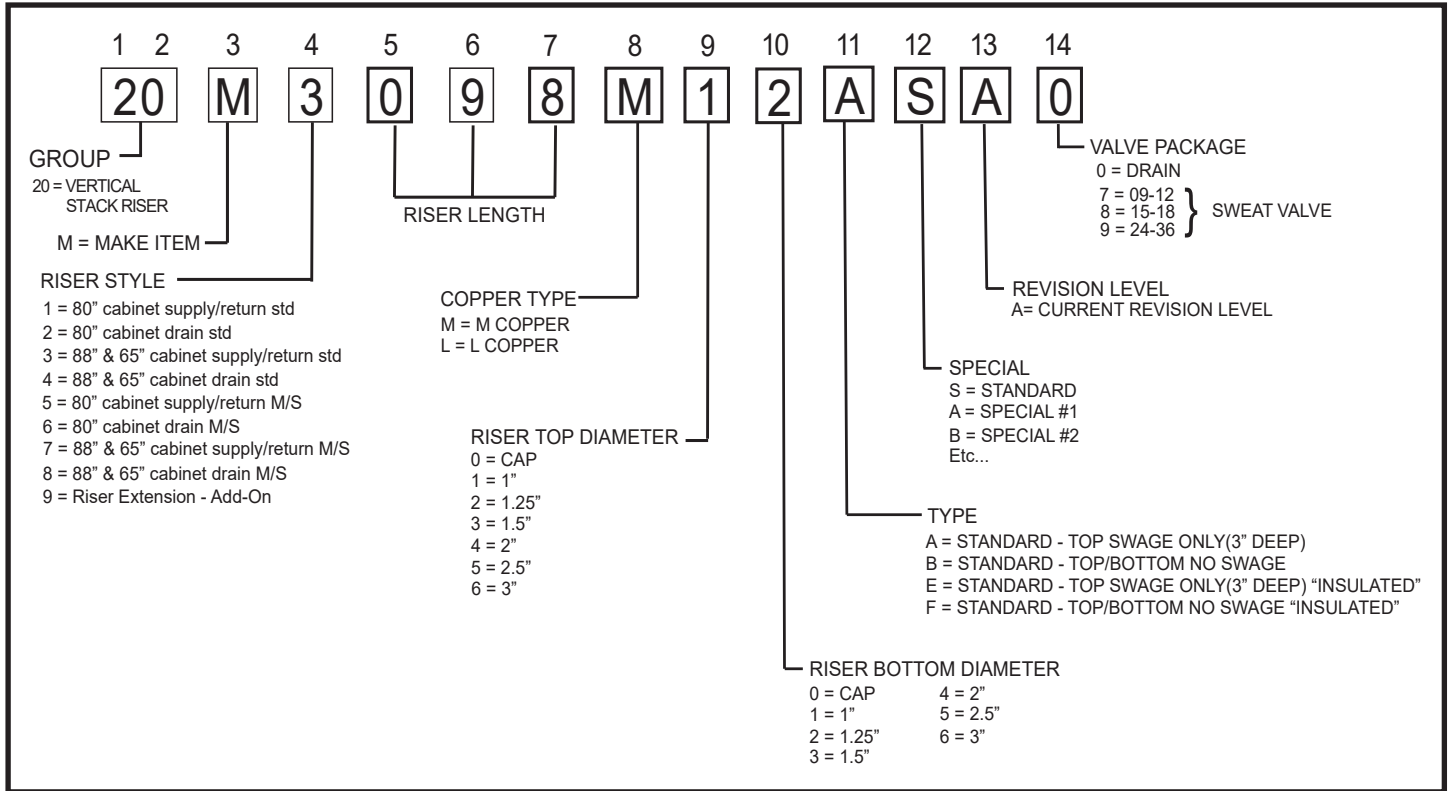

## Hose Kit

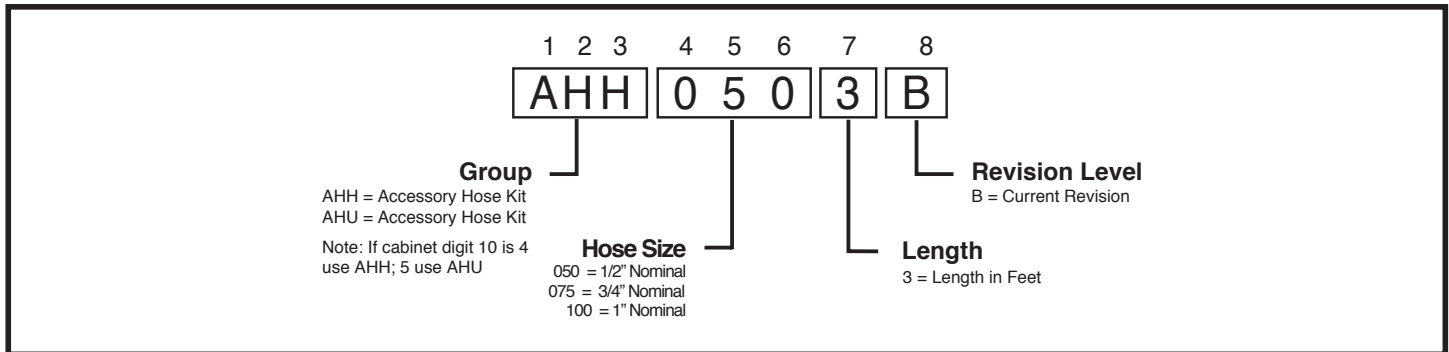

## Supply Air Grille

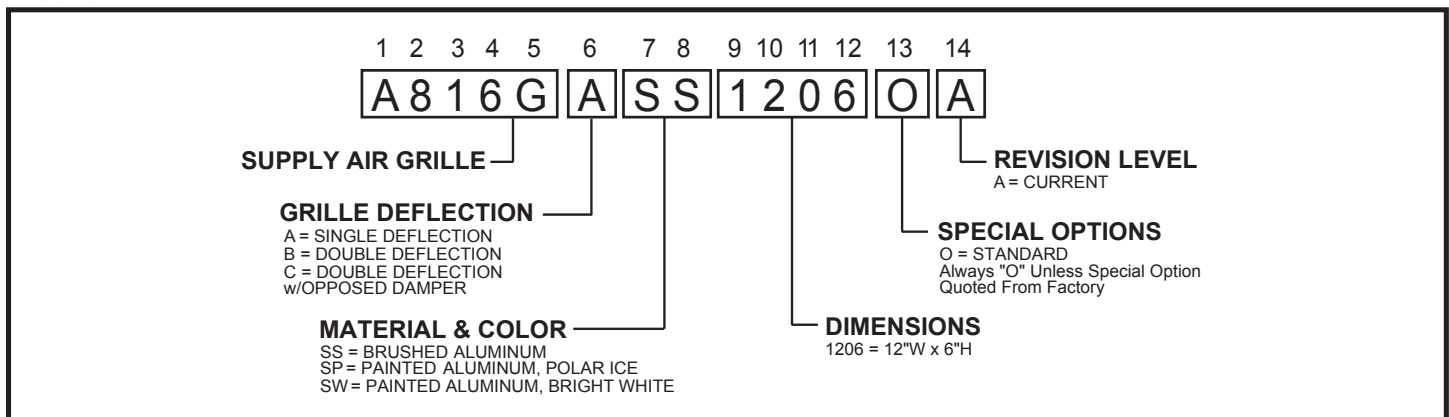

# TSM Series Accessory Nomenclature

## Cabinet Stands (Ship loose in bulk for field attachment)

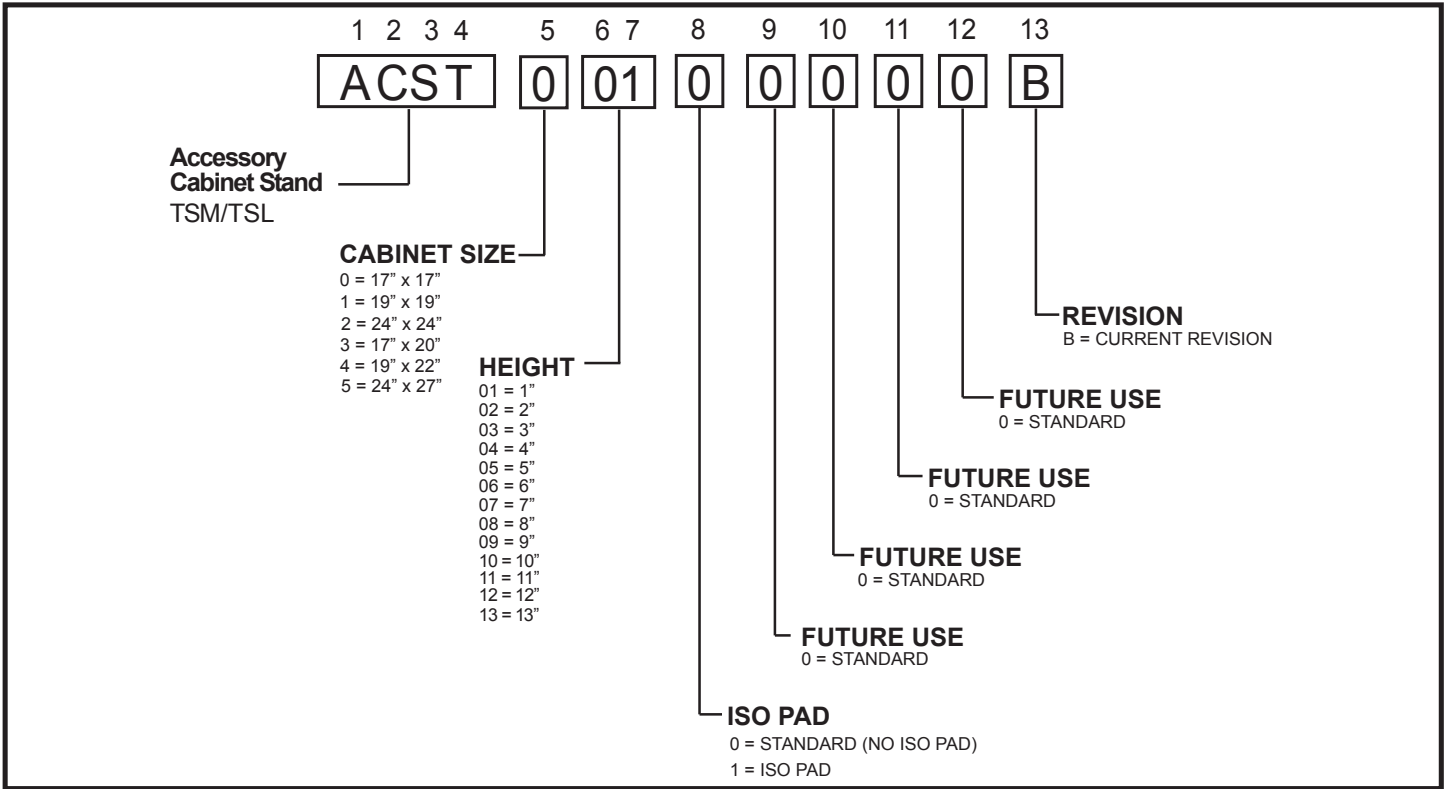

# Performance Data – AHRI/ASHRAE/ISO 13256-1

## AHRI/ASHRAE/ISO 13256-1. English (I-P) Units

Model with ECM Motor	Water Loop Heat Pump				Ground Loop Heat Pump			
	Cooling 86°F		Heating 68°F		Cooling 77°F		Heating 32°F	
	Capacity	EER	Capacity	COP	Capacity	EER	Capacity	COP
	Btuh	Btuh/W	Btuh		Btuh	Btuh/W	Btuh	
TSM09	9200	14.3	12200	5.4	9700	16.2	7100	3.3
TSM12	11800	14.1	15200	5.3	12100	16.8	9000	3.2
TSM15	14600	15.9	17500	5.3	15500	18.8	11000	3.6
TSM18	18000	15.2	22200	5.1	18500	17.3	13200	3.3
TSM24	25000	15.7	32500	5.1	26500	18.5	18200	3.5
TSM30	28000	15.1	34500	5.0	29000	17.6	22200	3.6
TSM36	35000	14.6	40500	5.0	36000	16.5	25500	3.5

Model with PSC Motor	Water Loop Heat Pump				Ground Loop Heat Pump			
	Cooling 86°F		Heating 68°F		Cooling 77°F		Heating 32°F	
	Capacity	EER	Capacity	COP	Capacity	EER	Capacity	COP
	Btuh	Btuh/W	Btuh		Btuh	Btuh/W	Btuh	
TSM09	9200	13.5	12200	5.0	9700	14.9	7100	3.2
TSM12	11800	13.7	15200	4.9	12100	15.0	9000	3.2
TSM15	14300	13.3	18000	4.8	15200	15.6	11500	3.3
TSM18	17300	13.2	22500	4.8	18400	15.1	13500	3.2
TSM24	25000	14.4	32500	4.9	26500	16.8	18400	3.4
TSM30	27500	13.4	34500	4.7	28500	15.2	22000	3.3
TSM36	35000	14.1	40500	4.9	36000	16.2	25500	3.4

Cooling capacities based upon 80.6°F DB, 66.2°F WB entering air temperature  
 Heating capacities based upon 68°F DB, 59°F WB entering air temperature  
 All units AHRI/ISO/ASHRAE 13256-1 rated on high speed motor TAP  
 All ratings based upon operation at lower voltage of dual voltage rated models

## AHRI/ASHRAE/ISO 13256-1. Metric (S-I) Units

Model with ECM Motor	Water Loop Heat Pump				Ground Loop Heat Pump			
	Cooling 30°C		Heating 20°C		Cooling 25°C		Heating 0°C	
	Capacity	EER	Capacity	COP	Capacity	EER	Capacity	COP
	kW	W/W	kW		kW	W/W	kW	
TSM09	2.70	4.2	3.58	5.4	2.84	4.8	2.08	3.3
TSM12	3.46	4.1	4.46	5.3	3.55	4.9	2.64	3.2
TSM15	4.28	4.7	5.13	5.3	4.55	5.5	3.23	3.6
TSM18	5.28	4.5	6.51	5.1	5.43	5.1	3.87	3.3
TSM24	7.33	4.6	9.53	5.1	7.77	5.4	5.34	3.5
TSM30	8.21	4.4	10.12	5	8.50	5.2	6.51	3.6
TSM36	10.26	4.3	11.88	5	10.56	4.8	7.48	3.5

Model with PSC Motor	Water Loop Heat Pump				Ground Loop Heat Pump			
	Cooling 30°C		Heating 20°C		Cooling 25°C		Heating 0°C	
	Capacity	EER	Capacity	COP	Capacity	EER	Capacity	COP
	kW	W/W	kW		kW	W/W	kW	
TSM09	2.70	4.0	3.58	5	2.84	4.4	2.08	3.2
TSM12	3.46	4.0	4.46	4.9	3.55	4.4	2.64	3.2
TSM15	4.19	3.9	5.28	4.8	4.46	4.6	3.37	3.3
TSM18	5.07	3.9	6.60	4.8	5.40	4.4	3.96	3.2
TSM24	7.33	4.2	9.53	4.9	7.77	4.9	5.40	3.4
TSM30	8.06	3.9	10.12	4.7	8.36	4.5	6.45	3.3
TSM36	10.26	4.1	11.88	4.9	10.56	4.8	7.48	3.4

Cooling capacities based upon 27°C DB, 19°C WB entering air temperature  
 Heating capacities based upon 20°C DB, 15°C WB entering air temperature  
 All units AHRI/ISO/ASHRAE 13256-1 rated on high speed motor TAP  
 All ratings based upon operation at lower voltage of dual voltage rated models

## Performance Data – Selection Notes

For operation in the lighter shaded area to determine if water can be used in lieu of an antifreeze solution, the Leaving Water Temperature (LWT) must be calculated. Flow must be maintained to a level such that the LWT is maintained above 42°F [5.6°C] when the CXM/DXM2 JW3 jumper is not clipped (see example below). Otherwise, appropriate levels (10° below LWT, See IOM) of a proper antifreeze should be used in systems with leaving water temperatures of 42°F [5.6°C] or below and the JW3 jumper should be clipped. This is due to the potential of the refrigerant temperature being as low as 32°F [0°C], which may lead to a nuisance cutout due to the activation of the Low Temperature Protection (LT1). JW3 should **never** be clipped for standard range equipment or systems without antifreeze.

### Example:

At 50°F EWT (Entering Water Temperature) and 1.5 gpm/ton, a 3 ton unit has a HE of 26,830 Btuh. To calculate LWT, rearrange the formula for HE as follows:

HE = TD x GPM x 500, where HE = Heat of Extraction (Btuh);  
 TD = temperature difference (EWT - LWT) and GPM = U.S. Gallons per Minute.

$$TD = HE / (GPM \times 500)$$

$$TD = 26,830 / (4.5 \times 500)$$

$$TD = 12^\circ\text{F}$$

$$\text{LWT} = \text{EWT} - \text{TD}$$

LWT = 50 - 12 = 38°F - Requires appropriate antifreeze (Protect to 28°F), JW3 must be clipped, and extended range insulation option.

In this example, a higher flow rate will be required for EWTs of 50°F without antifreeze. At 3 gpm/ton, the calculation becomes: (Note higher flow increases HE)

$$TD = 29,650 / (9\text{GPM} \times 500)$$

$$TD = 7^\circ\text{F}$$

LWT = 50 - 7 = 43°F - Water is acceptable, do not clip JW3.

		Heating - EAT 70°F					
	R	EER	HC	kW	HE	LAT	COP
ended			23.28	2.31	15.72	85.9	3.0
2	52.07	29.0	26.08	2.35	18.36	88.1	3.2
1	52.26	31.3	27.35	2.37	19.56	89.1	3.4
7	52.27	32.5	28.06	2.38	20.23	89.6	3.4
	51.56	26.0	30.51	2.42	22.56	91.5	3.7
	51.98	28.3	32.12	2.45	24.08	92.7	3.8
	52.12	29.4	33.01	2.46	24.92	93.4	3.9
	52	22.9	35.03	2.49	<u>26.83</u>	95.0	4.1
		25.3	36.94	2.52	28.65	96.4	4.3
		24	38.00	2.54	<u>29.65</u>	97.3	4.4
			39.53	2.56	31.09	98.4	4.5

# Performance Data – TSM09 with PSC Motor

## 400 CFM Nominal Airflow

Performance capacities shown in thousands of Btuh

EWT °F	GPM	WPD*		Cooling - EAT 80/67°F						Heating - EAT 70°F				
		PSI	FT	TC	SC	S/T	kW	HR	EER	HC	kW	HE	LAT	COP
20	1.13	1.6	3.6	Operation not recommended						5.7 0.64 3.5 83.1 2.6				
	1.69	3.0	6.9											
	2.25	4.9	11.3											
30	1.13	1.2	2.8	12.2	9.0	0.73	0.45	13.8	27.2	6.4	0.65	4.2	84.9	2.9
	1.69	2.7	6.2	12.2	8.7	0.72	0.42	13.6	28.9	6.8	0.65	4.5	85.6	3.0
	2.25	4.5	10.3	12.0	8.5	0.71	0.41	13.4	29.3	6.9	0.65	4.7	86.0	3.1
40	1.13	1.0	2.4	12.0	9.1	0.75	0.49	13.7	24.4	7.6	0.66	5.4	87.6	3.4
	1.69	1.9	4.5	12.2	9.0	0.74	0.46	13.8	26.7	8.0	0.66	5.8	88.5	3.5
	2.25	3.1	7.3	12.3	9.0	0.73	0.44	13.8	27.8	8.3	0.67	6.0	89.1	3.6
50	1.13	1.0	2.2	11.6	8.9	0.77	0.55	13.5	21.2	8.8	0.67	6.5	90.4	3.9
	1.69	1.9	4.3	12.0	9.0	0.75	0.50	13.7	23.8	9.3	0.68	7.0	91.6	4.1
	2.25	3.1	7.1	12.1	9.1	0.75	0.48	13.8	25.0	9.6	0.68	7.3	92.3	4.2
60	1.13	0.9	2.1	11.0	8.6	0.78	0.60	13.0	18.2	10.1	0.68	7.7	93.2	4.3
	1.69	1.8	4.2	11.5	8.8	0.77	0.56	13.4	20.6	10.7	0.69	8.4	94.7	4.6
	2.25	3.0	6.9	11.7	8.9	0.76	0.54	13.5	21.9	11.1	0.69	8.7	95.6	4.7
70	1.13	0.8	1.9	10.2	8.2	0.80	0.67	12.5	15.4	11.3	0.69	9.0	96.2	4.8
	1.69	1.8	4.1	10.8	8.5	0.78	0.62	12.9	17.5	12.1	0.70	9.7	97.9	5.1
	2.25	2.9	6.7	11.1	8.6	0.78	0.59	13.1	18.7	12.5	0.70	10.1	98.9	5.2
80	1.13	0.8	1.8	9.4	7.7	0.82	0.73	11.9	12.9	12.6	0.70	10.2	99.1	5.3
	1.69	1.7	3.9	10.0	8.0	0.80	0.68	12.4	14.7	13.5	0.71	11.1	101.1	5.6
	2.25	2.8	6.5	10.3	8.2	0.79	0.66	12.6	15.7	14.0	0.71	11.5	102.2	5.8
90	1.13	0.7	1.7	8.6	7.2	0.84	0.80	11.3	10.7	13.9	0.71	11.5	102.1	5.8
	1.69	1.6	3.8	9.2	7.5	0.82	0.75	11.8	12.2	14.8	0.71	12.4	104.3	6.1
	2.25	2.8	6.4	9.5	7.7	0.81	0.73	12.0	13.0	15.4	0.72	12.9	105.5	6.3
100	1.13	0.7	1.7	7.8	6.7	0.87	0.87	10.7	8.9	13.9	0.71	11.5	102.1	5.8
	1.69	1.6	3.7	8.3	7.1	0.85	0.82	11.1	10.1	13.9	0.71	11.5	102.1	5.8
	2.25	2.7	6.2	8.6	7.2	0.84	0.80	11.3	10.8	13.9	0.71	11.5	102.1	5.8
110	1.13	0.7	1.6	7.0	6.3	0.91	0.94	10.2	7.4	13.9	0.71	11.5	102.1	5.8
	1.69	1.6	3.6	7.5	6.6	0.88	0.90	10.5	8.3	13.9	0.71	11.5	102.1	5.8
	2.25	2.6	6.1	7.7	6.7	0.87	0.88	10.7	8.8	13.9	0.71	11.5	102.1	5.8
120	1.13	0.7	1.6	6.2	6.0	0.96	1.02	9.7	6.1	13.9	0.71	11.5	102.1	5.8
	1.69	1.5	3.5	6.7	6.2	0.93	0.97	10.0	6.8	13.9	0.71	11.5	102.1	5.8
	2.25	2.6	5.9	6.9	6.3	0.91	0.95	10.1	7.2	13.9	0.71	11.5	102.1	5.8

Interpolation is permissible, extrapolation is not.

All entering air conditions are 80°F DB and 67°F WB in cooling and 70°F DB in heating.

All performance data is based upon the lower voltage of dual voltage rated units.

See performance correction tables for operating conditions other than those listed above.

Table does not reflect corrections for Fan and Pump watts used is ISO-13256.

Operation below 40°F EWT is based upon 20% methanol antifreeze solution.

All performance data is based upon High speed.

Operation below 60°F requires optional insulated water/refrigerant circuit.

Operation in the darker shaded region is only permissible with use of CLM Modulating Water valve. At these conditions, water flow will be reduced in order to maintain a leaving water temperature of 70 °F

Operation in the lighter shaded areas may require antifreeze. See Performance Data Selection Notes for operation in the lighter shaded areas.

# Performance Data – TSM12 with PSC Motor

## 450 CFM Nominal Airflow

Performance capacities shown in thousands of Btuh

EWT °F	GPM	WPD*		Cooling - EAT 80/67°F						Heating - EAT 70°F				
		PSI	FT	TC	SC	S/T	kW	HR	EER	HC	kW	HE	LAT	COP
20	1.50	2.3	5.3	Operation not recommended						7.0	0.79	4.3	84.4	2.6
	2.25	4.7	10.8											
	3.00	7.8	18.0											
30	1.50	2.1	4.7	14.5	9.7	0.67	0.55	16.4	26.4	8.1	0.81	5.4	86.7	2.9
	2.25	4.3	9.9	14.2	9.3	0.65	0.52	16.0	27.3	8.6	0.82	5.8	87.6	3.1
	3.00	7.0	16.2	14.0	9.0	0.64	0.51	15.8	27.3	8.8	0.82	6.0	88.0	3.1
40	1.50	1.5	3.6	14.4	9.9	0.69	0.60	16.5	24.1	9.7	0.83	6.9	89.9	3.4
	2.25	3.1	7.3	14.5	9.8	0.67	0.56	16.4	25.9	10.2	0.84	7.4	91.0	3.6
	3.00	5.2	12.1	14.5	9.6	0.67	0.54	16.3	26.6	10.5	0.84	7.6	91.6	3.7
50	1.50	1.5	3.5	14.0	9.9	0.71	0.66	16.3	21.3	11.3	0.85	8.3	93.1	3.9
	2.25	3.1	7.1	14.4	10.0	0.69	0.61	16.5	23.5	11.9	0.86	8.9	94.4	4.0
	3.00	5.1	11.8	14.5	9.9	0.69	0.59	16.5	24.5	12.2	0.87	9.3	95.1	4.1
60	1.50	1.5	3.4	13.4	9.7	0.73	0.73	15.9	18.3	12.8	0.87	9.8	96.3	4.3
	2.25	3.0	6.9	13.9	9.9	0.71	0.68	16.2	20.5	13.5	0.88	10.5	97.8	4.5
	3.00	5.0	11.4	14.1	10.0	0.71	0.65	16.3	21.6	13.9	0.89	10.9	98.6	4.6
70	1.50	1.4	3.3	12.6	9.4	0.75	0.81	15.4	15.6	14.3	0.89	11.3	99.5	4.7
	2.25	2.9	6.7	13.2	9.7	0.73	0.75	15.8	17.5	15.2	0.91	12.1	101.2	4.9
	3.00	4.8	11.1	13.5	9.8	0.72	0.72	16.0	18.6	15.7	0.91	12.6	102.2	5.0
80	1.50	1.4	3.2	11.7	9.0	0.77	0.89	14.7	13.1	15.9	0.92	12.8	102.7	5.1
	2.25	2.8	6.5	12.3	9.3	0.75	0.84	15.2	14.8	16.9	0.93	13.8	104.8	5.4
	3.00	4.7	10.8	12.7	9.4	0.74	0.81	15.4	15.7	17.5	0.93	14.3	106.0	5.5
90	1.50	1.3	3.1	10.7	8.5	0.79	0.98	14.1	10.9	17.6	0.94	14.4	106.1	5.5
	2.25	2.8	6.4	11.4	8.8	0.77	0.92	14.5	12.3	18.8	0.95	15.5	108.5	5.8
	3.00	4.6	10.5	11.7	9.0	0.77	0.89	14.8	13.1	19.4	0.96	16.2	109.9	5.9
100	1.50	1.3	3.0	9.7	7.9	0.82	1.07	13.4	9.1	17.5	0.93	14.3	106.0	5.5
	2.25	2.7	6.2	10.3	8.3	0.80	1.01	13.8	10.2	17.5	0.93	14.3	106.0	5.5
	3.00	4.5	10.3	10.7	8.4	0.79	0.98	14.0	10.8	17.5	0.93	14.3	106.0	5.5
110	1.50	1.3	2.9	8.7	7.4	0.85	1.16	12.7	7.5	17.5	0.93	14.3	106.0	5.5
	2.25	2.6	6.1	9.3	7.7	0.83	1.11	13.1	8.4	17.5	0.93	14.3	106.0	5.5
	3.00	4.4	10.1	9.6	7.9	0.82	1.08	13.3	8.9	17.5	0.93	14.3	106.0	5.5
120	1.50	1.2	2.8	7.8	6.9	0.88	1.25	12.1	6.3	17.5	0.93	14.3	106.0	5.5
	2.25	2.6	5.9	8.3	7.2	0.86	1.20	12.4	7.0	17.5	0.93	14.3	106.0	5.5
	3.00	4.3	10.0	8.6	7.3	0.85	1.17	12.6	7.3	17.5	0.93	14.3	106.0	5.5

Interpolation is permissible, extrapolation is not.

All entering air conditions are 80°F DB and 67°F WB in cooling and 70°F DB in heating.

All performance data is based upon the lower voltage of dual voltage rated units.

See performance correction tables for operating conditions other than those listed above.

Table does not reflect corrections for Fan and Pump watts used is ISO-13256.

Operation below 40°F EWT is based upon 20% methanol antifreeze solution.

All performance data is based upon High speed.

Operation below 60°F requires optional insulated water/refrigerant circuit.

Operation in the darker shaded region is only permissible with use of CLM Modulating Water valve. At these conditions, water flow will be reduced in order to maintain a leaving water temperature of 70 °F

Operation in the lighter shaded areas may require antifreeze. See Performance Data Selection Notes for operation in the lighter shaded areas.

# Performance Data – TSM15 with PSC Motor

## 600 CFM Nominal Airflow

Performance capacities shown in thousands of Btu/h

EWT °F	GPM	WPD*		Cooling - EAT 80/67°F						Heating - EAT 70°F									
		PSI	FT	TC	SC	S/T	kW	HR	EER	HC	kW	HE	LAT	COP					
20	1.88	0.8	1.8	Operation not recommended						10.1	1.04	6.5	85.5	2.8					
	2.81	1.6	3.8																
	3.75	2.7	6.3																
30	1.88	0.6	1.5	18.9	13.9	0.74	0.71	21.3	26.7	11.4	1.06	7.8	87.5	3.1					
	2.81	1.4	3.2	18.5	12.9	0.70	0.67	20.8	27.5	12.0	1.07	8.3	88.5	3.3					
	3.75	2.3	5.4	18.1	12.2	0.68	0.66	20.3	27.5	12.4	1.08	8.7	89.0	3.4					
40	1.88	0.4	1.0	18.8	14.4	0.77	0.78	21.4	24.2	13.5	1.09	9.8	90.8	3.6					
	2.81	0.9	2.1	18.9	14.1	0.74	0.72	21.4	26.2	14.3	1.10	10.6	92.1	3.8					
	3.75	1.5	3.5	18.8	13.7	0.73	0.70	21.2	26.9	14.8	1.11	11.0	92.8	3.9					
50	1.88	0.4	0.9	18.1	14.2	0.78	0.86	21.1	21.1	15.7	1.12	11.9	94.1	4.1					
	2.81	0.9	2.0	18.7	14.4	0.77	0.79	21.4	23.5	16.7	1.13	12.9	95.8	4.3					
	3.75	1.4	3.3	18.8	14.3	0.76	0.76	21.4	24.6	17.3	1.14	13.4	96.7	4.5					
60	1.88	0.4	0.9	17.2	13.7	0.80	0.96	20.5	17.9	17.9	1.14	14.0	97.6	4.6					
	2.81	0.8	1.9	17.9	14.1	0.79	0.88	21.0	20.3	19.2	1.15	15.2	99.5	4.9					
	3.75	1.4	3.2	18.3	14.3	0.78	0.85	21.2	21.5	19.9	1.16	15.9	100.6	5.0					
70	1.88	0.4	0.8	16.0	12.9	0.81	1.06	19.6	15.0	20.2	1.16	16.2	101.1	5.1					
	2.81	0.8	1.8	16.9	13.5	0.80	0.99	20.3	17.1	21.6	1.17	17.6	103.3	5.4					
	3.75	1.3	3.0	17.3	13.8	0.79	0.95	20.5	18.3	22.4	1.18	18.4	104.5	5.6					
80	1.88	0.3	0.8	14.7	12.1	0.82	1.18	18.7	12.5	22.4	1.18	18.4	104.5	5.6					
	2.81	0.7	1.7	15.6	12.7	0.81	1.10	19.4	14.2	24.0	1.19	20.0	107.0	5.9					
	3.75	1.3	2.9	16.1	13.0	0.81	1.06	19.7	15.2	24.9	1.19	20.9	108.4	6.1					
90	1.88	0.3	0.8	13.4	11.2	0.84	1.30	17.8	10.3	24.6	1.19	20.6	107.9	6.1					
	2.81	0.7	1.7	14.3	11.8	0.82	1.22	18.4	11.7	26.4	1.20	22.3	110.6	6.4					
	3.75	1.2	2.8	14.7	12.1	0.82	1.18	18.8	12.5	27.3	1.21	23.2	112.0	6.6					
100	1.88	0.3	0.7	12.1	10.5	0.87	1.42	17.0	8.5	24.9	1.19	20.9	108.4	6.1					
	2.81	0.7	1.6	12.9	10.9	0.85	1.34	17.5	9.6	24.9	1.19	20.9	108.4	6.1					
	3.75	1.2	2.7	13.3	11.2	0.84	1.30	17.8	10.2	24.9	1.19	20.9	108.4	6.1					
110	1.88	0.3	0.7	11.0	10.0	0.91	1.55	16.3	7.1	24.9	1.19	20.9	108.4	6.1					
	2.81	0.7	1.5	11.7	10.3	0.88	1.47	16.7	7.9	24.9	1.19	20.9	108.4	6.1					
	3.75	1.1	2.6	12.0	10.5	0.87	1.43	16.9	8.4	24.9	1.19	20.9	108.4	6.1					
120	1.88	0.3	0.7	10.1	9.9	0.98	1.68	15.9	6.1	24.9	1.19	20.9	108.4	6.1					
	2.81	0.6	1.5	10.6	9.9	0.94	1.60	16.1	6.6	24.9	1.19	20.9	108.4	6.1					
	3.75	1.1	2.5	10.9	10.0	0.92	1.56	16.2	7.0	24.9	1.19	20.9	108.4	6.1					

Interpolation is permissible, extrapolation is not.  
 All entering air conditions are 80°F DB and 67°F WB in cooling and 70°F DB in heating.  
 All performance data is based upon the lower voltage of dual voltage rated units.  
 See performance correction tables for operating conditions other than those listed above.  
 Table does not reflect corrections for Fan and Pump watts used is ISO-13256.  
 Operation below 40°F EWT is based upon 20% methanol antifreeze solution.  
 All performance data is based upon High speed.  
 Operation below 60°F requires optional insulated water/refrigerant circuit.  
 Operation in the darker shaded region is only permissible with use of CLM Modulating Water valve. At these conditions, water flow will be reduced in order to maintain a leaving water temperature of 70 °F  
 Operation in the lighter shaded areas may require antifreeze. See Performance Data Selection Notes for operation in the lighter shaded areas.

# Performance Data – TSM18 with PSC Motor

## 700 CFM Nominal Airflow

Performance capacities shown in thousands of Btuh

EWT °F	GPM	WPD*		Cooling - EAT 80/67°F						Heating - EAT 70°F				
		PSI	FT	TC	SC	S/T	kW	HR	EER	HC	kW	HE	LAT	COP
20	2.25	0.8	1.8	Operation not recommended						9.9 1.13 6.1 83.1 2.6				
	3.38	1.9	4.4											
	4.50	3.3	7.7											
30	2.25	0.6	1.4	20.4	14.1	0.69	0.78	23.1	26.1	11.8	1.16	7.9	85.6	3.0
	3.38	1.6	3.7	20.2	13.6	0.67	0.74	22.8	27.5	12.5	1.17	8.5	86.5	3.1
	4.50	2.8	6.6	20.0	13.2	0.66	0.72	22.5	27.9	12.8	1.18	8.8	86.9	3.2
40	2.25	0.5	1.1	20.2	14.3	0.71	0.87	23.1	23.3	14.3	1.20	10.2	88.9	3.5
	3.38	1.2	2.7	20.4	14.2	0.70	0.81	23.2	25.3	15.1	1.21	10.9	89.9	3.7
	4.50	2.0	4.7	20.4	14.1	0.69	0.78	23.1	26.2	15.5	1.22	11.4	90.5	3.7
50	2.25	0.4	1.0	19.5	14.1	0.73	0.96	22.7	20.3	16.6	1.23	12.4	91.9	4.0
	3.38	1.1	2.6	20.0	14.3	0.71	0.89	23.1	22.4	17.5	1.24	13.3	93.1	4.1
	4.50	2.0	4.5	20.2	14.3	0.71	0.86	23.1	23.5	18.0	1.25	13.7	93.7	4.2
60	2.25	0.4	1.0	18.4	13.7	0.74	1.07	22.1	17.3	18.8	1.25	14.5	94.8	4.4
	3.38	1.1	2.5	19.2	14.0	0.73	0.99	22.6	19.3	19.8	1.26	15.5	96.1	4.6
	4.50	1.9	4.3	19.5	14.1	0.72	0.96	22.8	20.4	20.3	1.27	16.0	96.8	4.7
70	2.25	0.4	0.9	17.2	13.0	0.76	1.18	21.2	14.5	20.9	1.28	16.5	97.6	4.8
	3.38	1.0	2.4	18.0	13.5	0.75	1.10	21.8	16.3	22.0	1.29	17.6	99.0	5.0
	4.50	1.8	4.1	18.4	13.7	0.74	1.07	22.1	17.3	22.5	1.29	18.1	99.7	5.1
80	2.25	0.4	0.9	15.7	12.3	0.78	1.31	20.2	12.0	22.9	1.30	18.5	100.2	5.2
	3.38	1.0	2.2	16.7	12.8	0.77	1.23	20.8	13.5	24.1	1.31	19.6	101.8	5.4
	4.50	1.7	4.0	17.1	13.0	0.76	1.19	21.2	14.4	24.7	1.32	20.2	102.6	5.5
90	2.25	0.4	0.8	14.2	11.6	0.81	1.45	19.2	9.8	24.9	1.32	20.3	102.8	5.5
	3.38	0.9	2.1	15.1	12.0	0.79	1.37	19.8	11.1	26.1	1.34	21.5	104.5	5.7
	4.50	1.6	3.8	15.6	12.2	0.78	1.32	20.1	11.8	26.8	1.35	22.2	105.4	5.8
100	2.25	0.3	0.8	12.7	10.9	0.85	1.60	18.2	7.9	24.1	1.31	19.6	101.8	5.4
	3.38	0.9	2.1	13.6	11.3	0.83	1.52	18.8	9.0	24.1	1.31	19.6	101.8	5.4
	4.50	1.6	3.7	14.0	11.5	0.82	1.47	19.1	9.5	24.1	1.31	19.6	101.8	5.4
110	2.25	0.3	0.7	11.3	10.2	0.91	1.77	17.3	6.4	24.1	1.31	19.6	101.8	5.4
	3.38	0.9	2.0	12.1	10.6	0.87	1.68	17.8	7.2	24.1	1.31	19.6	101.8	5.4
	4.50	1.5	3.6	12.5	10.7	0.86	1.63	18.0	7.6	24.1	1.31	19.6	101.8	5.4
120	2.25	0.3	0.7	10.0	9.8	0.97	1.95	16.7	5.1	24.1	1.31	19.6	101.8	5.4
	3.38	0.8	1.9	10.6	10.0	0.94	1.86	17.0	5.7	24.1	1.31	19.6	101.8	5.4
	4.50	1.5	3.4	11.0	10.1	0.92	1.81	17.2	6.1	24.1	1.31	19.6	101.8	5.4

Interpolation is permissible, extrapolation is not.

All entering air conditions are 80°F DB and 67°F WB in cooling and 70°F DB in heating.

All performance data is based upon the lower voltage of dual voltage rated units.

See performance correction tables for operating conditions other than those listed above.

Table does not reflect corrections for Fan and Pump watts used is ISO-13256.

Operation below 40°F EWT is based upon 20% methanol antifreeze solution.

All performance data is based upon High speed.

Operation below 60°F requires optional insulated water/refrigerant circuit.

Operation in the darker shaded region is only permissible with use of CLM Modulating Water valve. At these conditions, water flow will be reduced in order to maintain a leaving water temperature of 70 °F

Operation in the lighter shaded areas may require antifreeze. See Performance Data Selection Notes for operation in the lighter shaded areas.



# Performance Data – TSM24 with PSC Motor

## 800 CFM Nominal Airflow

Performance capacities shown in thousands of Btu/h

EWT °F	GPM	WPD*		Cooling - EAT 80/67°F						Heating - EAT 70°F				
		PSI	FT	TC	SC	S/T	kW	HR	EER	HC	kW	HE	LAT	COP
20	3.00	1.2	2.8	Operation not recommended						15.8 1.72 10.0 88.3 2.7				
	4.50	2.5	5.9											
	6.00	4.1	9.6											
30	3.00	1.0	2.4	31.0	21.6	0.70	1.18	35.0	26.3	18.0	1.76	12.0	90.8	3.0
	4.50	2.1	5.0	31.2	21.7	0.70	1.09	34.9	28.7	18.9	1.77	12.9	91.9	3.1
	6.00	3.6	8.2	31.2	21.7	0.70	1.05	34.8	29.8	19.5	1.78	13.4	92.5	3.2
40	3.00	0.8	1.7	30.4	21.3	0.70	1.30	34.8	23.4	21.2	1.81	15.1	94.5	3.4
	4.50	1.6	3.6	30.9	21.6	0.70	1.20	35.0	25.7	22.4	1.83	16.2	95.9	3.6
	6.00	2.5	5.9	31.1	21.7	0.70	1.16	35.0	26.9	23.1	1.84	16.8	96.7	3.7
50	3.00	0.7	1.7	29.5	20.9	0.71	1.43	34.4	20.6	24.5	1.86	18.1	98.3	3.9
	4.50	1.5	3.4	30.2	21.2	0.70	1.33	34.8	22.8	25.9	1.88	19.5	99.9	4.0
	6.00	2.4	5.6	30.5	21.4	0.70	1.28	34.9	24.0	26.7	1.90	20.2	100.8	4.1
60	3.00	0.7	1.6	28.3	20.3	0.72	1.58	33.7	17.9	27.7	1.91	21.2	102.0	4.2
	4.50	1.4	3.3	29.2	20.8	0.71	1.46	34.2	20.0	29.3	1.94	22.7	103.9	4.4
	6.00	2.3	5.4	29.7	21.0	0.71	1.41	34.5	21.1	30.3	1.96	23.6	104.9	4.5
70	3.00	0.7	1.5	26.9	19.7	0.73	1.76	32.9	15.3	30.9	1.97	24.1	105.6	4.6
	4.50	1.4	3.1	28.0	20.2	0.72	1.62	33.5	17.2	32.7	2.00	25.9	107.8	4.8
	6.00	2.2	5.2	28.5	20.4	0.72	1.56	33.8	18.3	33.7	2.02	26.8	108.9	4.9
80	3.00	0.6	1.4	25.4	18.9	0.75	1.95	32.0	13.0	34.0	2.03	27.0	109.2	4.9
	4.50	1.3	3.0	26.5	19.5	0.73	1.80	32.7	14.7	36.0	2.08	28.9	111.5	5.1
	6.00	2.1	5.0	27.1	19.8	0.73	1.73	33.0	15.6	37.0	2.10	29.9	112.8	5.2
90	3.00	0.6	1.4	23.7	18.2	0.77	2.18	31.2	10.9	37.0	2.10	29.8	112.7	5.2
	4.50	1.2	2.9	24.9	18.7	0.75	2.01	31.8	12.4	39.1	2.17	31.7	115.1	5.3
	6.00	2.1	4.8	25.5	19.0	0.75	1.93	32.1	13.2	40.2	2.21	32.7	116.4	5.3
100	3.00	0.6	1.3	22.0	17.3	0.79	2.44	30.3	9.0	37.0	2.10	29.9	112.8	5.2
	4.50	1.2	2.8	23.2	17.9	0.77	2.26	30.9	10.3	37.0	2.10	29.9	112.8	5.2
	6.00	2.0	4.6	23.8	18.2	0.76	2.17	31.2	11.0	37.0	2.10	29.9	112.8	5.2
110	3.00	0.6	1.3	20.2	16.4	0.81	2.75	29.6	7.4	37.0	2.10	29.9	112.8	5.2
	4.50	1.2	2.7	21.4	17.0	0.80	2.54	30.1	8.4	37.0	2.10	29.9	112.8	5.2
	6.00	1.9	4.5	22.0	17.3	0.79	2.44	30.3	9.0	37.0	2.10	29.9	112.8	5.2
120	3.00	0.5	1.2	18.4	15.5	0.84	3.10	29.0	5.9	37.0	2.10	29.9	112.8	5.2
	4.50	1.1	2.6	19.6	16.1	0.82	2.86	29.4	6.9	37.0	2.10	29.9	112.8	5.2
	6.00	1.9	4.4	20.2	16.4	0.81	2.75	29.6	7.4	37.0	2.10	29.9	112.8	5.2

Interpolation is permissible, extrapolation is not.  
 All entering air conditions are 80°F DB and 67°F WB in cooling and 70°F DB in heating.  
 All performance data is based upon the lower voltage of dual voltage rated units.  
 See performance correction tables for operating conditions other than those listed above.  
 Table does not reflect corrections for Fan and Pump watts used is ISO-13256.  
 Operation below 40°F EWT is based upon 20% methanol antifreeze solution.  
 All performance data is based upon High speed.  
 Operation below 60°F requires optional insulated water/refrigerant circuit.  
 Operation in the darker shaded region is only permissible with use of CLM Modulating Water valve. At these conditions, water flow will be reduced in order to maintain a leaving water temperature of 70 °F  
 Operation in the lighter shaded areas may require antifreeze. See Performance Data Selection Notes for operation in the lighter shaded areas.

# Performance Data – TSM30 with PSC Motor

## 1,000 CFM Nominal Airflow

Performance capacities shown in thousands of Btuh

EWT °F	GPM	WPD*		Cooling - EAT 80/67°F						Heating - EAT 70°F									
		PSI	FT	TC	SC	S/T	kW	HR	EER	HC	kW	HE	LAT	COP					
20	3.75	1.5	3.5	Operation not recommended						18.1	1.90	11.6	86.7	2.8					
	5.63	3.3	7.5																
	7.50	5.4	12.6																
30	3.75	1.3	3.1	33.7	23.5	0.70	1.31	38.1	25.8	20.4	1.91	13.9	88.8	3.1					
	5.63	2.9	6.6	33.3	22.8	0.69	1.23	37.5	27.1	21.3	1.92	14.8	89.7	3.3					
	7.50	5.0	11.6	33.0	22.4	0.68	1.19	37.1	27.6	21.8	1.92	15.3	90.2	3.3					
40	3.75	1.0	2.3	33.6	23.7	0.71	1.43	38.4	23.5	23.8	1.94	17.1	92.0	3.6					
	5.63	2.1	4.9	33.7	23.6	0.70	1.34	38.3	25.2	24.9	1.95	18.3	93.0	3.7					
	7.50	3.5	8.0	33.7	23.4	0.70	1.30	38.1	25.9	25.5	1.96	18.9	93.6	3.8					
50	3.75	1.0	2.2	32.9	23.4	0.71	1.56	38.2	21.0	27.1	1.97	20.4	95.0	4.0					
	5.63	2.0	4.7	33.4	23.7	0.71	1.47	38.4	22.8	28.4	1.99	21.6	96.2	4.2					
	7.50	3.4	7.9	33.6	23.7	0.71	1.42	38.4	23.7	29.1	2.00	22.3	96.9	4.3					
60	3.75	0.9	2.1	31.7	22.8	0.72	1.72	37.5	18.4	30.4	2.02	23.5	98.0	4.4					
	5.63	2.0	4.5	32.5	23.3	0.72	1.61	38.0	20.2	31.9	2.04	24.9	99.4	4.6					
	7.50	3.3	7.7	32.9	23.5	0.71	1.56	38.2	21.1	32.7	2.05	25.7	100.2	4.7					
70	3.75	0.9	2.0	30.1	21.9	0.73	1.89	36.6	15.9	33.6	2.07	26.5	101.0	4.8					
	5.63	1.9	4.4	31.2	22.5	0.72	1.77	37.2	17.6	35.3	2.10	28.1	102.6	4.9					
	7.50	3.2	7.5	31.7	22.8	0.72	1.71	37.5	18.5	36.2	2.12	29.0	103.4	5.0					
80	3.75	0.9	2.0	28.3	20.9	0.74	2.10	35.4	13.5	36.8	2.13	29.5	104.0	5.1					
	5.63	1.8	4.2	29.5	21.6	0.73	1.96	36.2	15.0	38.7	2.17	31.3	105.7	5.2					
	7.50	3.2	7.3	30.1	21.9	0.73	1.90	36.6	15.9	39.7	2.20	32.2	106.7	5.3					
90	3.75	0.8	1.9	26.2	19.9	0.76	2.33	34.2	11.2	40.0	2.20	32.5	106.9	5.3					
	5.63	1.8	4.1	27.5	20.5	0.75	2.18	35.0	12.6	42.0	2.26	34.3	108.8	5.5					
	7.50	3.1	7.1	28.2	20.9	0.74	2.11	35.4	13.4	43.1	2.29	35.3	109.8	5.5					
100	3.75	0.8	1.8	24.1	18.9	0.78	2.60	33.0	9.2	38.7	2.17	31.3	105.7	5.2					
	5.63	1.7	3.9	25.4	19.5	0.77	2.43	33.7	10.4	38.7	2.17	31.3	105.7	5.2					
	7.50	3.0	6.8	26.1	19.8	0.76	2.35	34.1	11.1	38.7	2.17	31.3	105.7	5.2					
110	3.75	0.8	1.8	21.9	17.9	0.82	2.92	31.8	7.5	38.7	2.17	31.3	105.7	5.2					
	5.63	1.7	3.8	23.2	18.5	0.80	2.73	32.5	8.5	38.7	2.17	31.3	105.7	5.2					
	7.50	2.8	6.6	23.8	18.8	0.79	2.64	32.8	9.0	38.7	2.17	31.3	105.7	5.2					
120	3.75	0.7	1.7	19.7	17.1	0.87	3.27	30.9	6.0	38.7	2.17	31.3	105.7	5.2					
	5.63	1.6	3.7	20.9	17.6	0.84	3.07	31.4	6.8	38.7	2.17	31.3	105.7	5.2					
	7.50	2.7	6.3	21.6	17.8	0.83	2.96	31.7	7.3	38.7	2.17	31.3	105.7	5.2					

Interpolation is permissible, extrapolation is not.  
 All entering air conditions are 80°F DB and 67°F WB in cooling and 70°F DB in heating.  
 All performance data is based upon the lower voltage of dual voltage rated units.  
 See performance correction tables for operating conditions other than those listed above.  
 Table does not reflect corrections for Fan and Pump watts used is ISO-13256.  
 Operation below 40°F EWT is based upon 20% methanol antifreeze solution.  
 All performance data is based upon High speed.  
 Operation below 60°F requires optional insulated water/refrigerant circuit.  
 Operation in the darker shaded region is only permissible with use of CLM Modulating Water valve. At these conditions, water flow will be reduced in order to maintain a leaving water temperature of 70 °F  
 Operation in the lighter shaded areas may require antifreeze. See Performance Data Selection Notes for operation in the lighter shaded areas.

# Performance Data – TSM36 with PSC Motor

## 1,200 CFM Nominal Airflow

Performance capacities shown in thousands of Btuh

EWT °F	GPM	WPD*		Cooling - EAT 80/67°F						Heating - EAT 70°F										
		PSI	FT	TC	SC	S/T	kW	HR	EER	HC	kW	HE	LAT	COP						
20	4.50	2.2	5.1	Operation not recommended						22.7	2.25	15.0	87.5	3.0						
	6.75	4.5	10.3																	
	9.00	7.2	16.7																	
30	4.50	1.8	4.2	41.0	28.2	0.69	1.65	46.6	24.9	25.1	2.28	17.3	89.3	3.2						
	6.75	3.6	8.4	40.1	27.4	0.68	1.55	45.4	25.9	26.1	2.30	18.2	90.1	3.3						
	9.00	5.9	13.6	39.4	26.9	0.68	1.50	44.5	26.2	26.6	2.31	18.8	90.5	3.4						
40	4.50	1.5	3.4	41.2	28.6	0.69	1.80	47.3	22.9	28.9	2.34	20.9	92.2	3.6						
	6.75	2.9	6.8	41.2	28.4	0.69	1.69	46.9	24.4	30.2	2.37	22.1	93.3	3.7						
	9.00	4.8	11.0	40.9	28.1	0.69	1.64	46.5	25.0	30.9	2.38	22.8	93.8	3.8						
50	4.50	1.4	3.2	40.4	28.4	0.70	1.97	47.1	20.5	32.9	2.41	24.7	95.3	4.0						
	6.75	2.8	6.4	41.0	28.6	0.70	1.84	47.3	22.2	34.5	2.44	26.2	96.6	4.1						
	9.00	4.5	10.4	41.2	28.6	0.69	1.79	47.3	23.0	35.4	2.45	27.0	97.2	4.2						
60	4.50	1.3	3.1	38.8	27.7	0.71	2.16	46.2	18.0	37.0	2.48	28.5	98.5	4.4						
	6.75	2.6	6.1	40.0	28.2	0.71	2.02	46.9	19.8	38.8	2.51	30.2	99.8	4.5						
	9.00	4.3	9.9	40.4	28.4	0.70	1.96	47.1	20.7	39.7	2.53	31.1	100.6	4.6						
70	4.50	1.3	2.9	36.8	26.7	0.72	2.38	45.0	15.4	40.9	2.55	32.2	101.5	4.7						
	6.75	2.5	5.8	38.3	27.4	0.72	2.23	45.9	17.2	42.7	2.59	33.9	102.9	4.8						
	9.00	4.0	9.3	38.9	27.7	0.71	2.15	46.3	18.1	43.7	2.61	34.8	103.7	4.9						
80	4.50	1.2	2.7	34.5	25.4	0.74	2.65	43.5	13.0	44.5	2.62	35.5	104.2	5.0						
	6.75	2.3	5.4	36.1	26.3	0.73	2.47	44.5	14.6	46.3	2.66	37.2	105.6	5.1						
	9.00	3.8	8.8	36.9	26.7	0.72	2.38	45.0	15.5	47.1	2.68	38.0	106.3	5.2						
90	4.50	1.1	2.6	32.0	24.0	0.75	2.96	42.1	10.8	47.5	2.69	38.4	106.6	5.2						
	6.75	2.2	5.1	33.6	24.9	0.74	2.75	43.0	12.2	49.0	2.72	39.7	107.7	5.3						
	9.00	3.6	8.3	34.5	25.4	0.74	2.65	43.5	13.0	49.7	2.74	40.3	108.2	5.3						
100	4.50	1.1	2.5	29.4	22.6	0.77	3.32	40.8	8.9	46.3	2.66	37.2	105.6	5.1						
	6.75	2.1	4.9	31.0	23.5	0.76	3.09	41.6	10.1	46.3	2.66	37.2	105.6	5.1						
	9.00	3.5	8.0	31.8	23.9	0.75	2.97	42.0	10.7	46.3	2.66	37.2	105.6	5.1						
110	4.50	1.0	2.4	27.0	21.2	0.78	3.76	39.8	7.2	46.3	2.66	37.2	105.6	5.1						
	6.75	2.0	4.7	28.5	22.0	0.77	3.48	40.4	8.2	46.3	2.66	37.2	105.6	5.1						
	9.00	3.3	7.7	29.2	22.4	0.77	3.36	40.7	8.7	46.3	2.66	37.2	105.6	5.1						
120	4.50	1.0	2.3	24.9	20.0	0.80	4.27	39.5	5.8	46.3	2.66	37.2	105.6	5.1						
	6.75	2.0	4.5	26.1	20.7	0.79	3.96	39.6	6.6	46.3	2.66	37.2	105.6	5.1						
	9.00	3.2	7.4	26.8	21.1	0.79	3.81	39.8	7.0	46.3	2.66	37.2	105.6	5.1						

Interpolation is permissible, extrapolation is not.  
 All entering air conditions are 80°F DB and 67°F WB in cooling and 70°F DB in heating.  
 All performance data is based upon the lower voltage of dual voltage rated units.  
 See performance correction tables for operating conditions other than those listed above.  
 Table does not reflect corrections for Fan and Pump watts used is ISO-13256.  
 Operation below 40°F EWT is based upon 20% methanol antifreeze solution.  
 All performance data is based upon High speed.  
 Operation below 60°F requires optional insulated water/refrigerant circuit.  
 Operation in the darker shaded region is only permissible with use of CLM Modulating Water valve. At these conditions, water flow will be reduced in order to maintain a leaving water temperature of 70 °F  
 Operation in the lighter shaded areas may require antifreeze. See Performance Data Selection Notes for operation in the lighter shaded areas.

# Performance Data – TSM09 with ECM Motor

## 400 CFM Nominal Airflow

Performance capacities shown in thousands of Btuh

EWT °F	GPM	WPD		Cooling - EAT 80/67°F						Heating - EAT 70°F									
		PSI	FT	TC	SC	S/T	kW	HR	EER	HC	kW	HE	LAT	COP					
20	1.13	1.6	3.6	Operation not recommended						5.4	0.60	3.4	82.5	2.6					
	1.69	3.0	6.9																
	2.25	4.9	11.3																
30	1.13	1.2	2.8	12.3	9.0	0.73	0.42	13.7	29.3	6.2	0.61	4.1	84.2	2.9					
	1.69	2.7	6.2	12.2	8.7	0.72	0.39	13.5	31.2	6.5	0.62	4.4	84.9	3.1					
	2.25	4.5	10.3	12.0	8.5	0.71	0.38	13.3	31.8	6.6	0.62	4.5	85.3	3.1					
40	1.13	1.0	2.4	12.1	9.1	0.75	0.46	13.6	26.1	7.3	0.63	5.2	86.8	3.4					
	1.69	1.9	4.5	12.2	9.0	0.74	0.43	13.7	28.7	7.7	0.63	5.5	87.8	3.6					
	2.25	3.1	7.3	12.3	8.9	0.73	0.41	13.7	29.9	7.9	0.63	5.7	88.3	3.7					
50	1.13	1.0	2.2	11.6	8.9	0.77	0.51	13.4	22.6	8.5	0.64	6.3	89.6	3.9					
	1.69	1.9	4.3	12.0	9.0	0.75	0.47	13.6	25.4	9.0	0.64	6.8	90.7	4.1					
	2.25	3.1	7.1	12.1	9.1	0.75	0.45	13.7	26.8	9.2	0.65	7.0	91.4	4.2					
60	1.13	0.9	2.1	11.0	8.6	0.78	0.57	12.9	19.3	9.7	0.65	7.5	92.4	4.4					
	1.69	1.8	4.2	11.5	8.8	0.77	0.53	13.3	21.9	10.3	0.66	8.0	93.7	4.6					
	2.25	3.0	6.9	11.7	8.9	0.76	0.50	13.4	23.3	10.6	0.66	8.4	94.5	4.7					
70	1.13	0.8	1.9	10.3	8.2	0.80	0.63	12.4	16.2	10.9	0.66	8.7	95.2	4.8					
	1.69	1.8	4.1	10.8	8.5	0.78	0.59	12.8	18.5	11.6	0.67	9.3	96.8	5.1					
	2.25	2.9	6.7	11.1	8.6	0.78	0.56	13.0	19.8	12.0	0.67	9.7	97.7	5.3					
80	1.13	0.8	1.8	9.5	7.7	0.81	0.70	11.8	13.5	12.1	0.67	9.9	98.1	5.3					
	1.69	1.7	3.9	10.0	8.0	0.80	0.65	12.3	15.4	13.0	0.67	10.7	99.9	5.6					
	2.25	2.8	6.5	10.3	8.2	0.79	0.63	12.5	16.5	13.4	0.68	11.1	101.0	5.8					
90	1.13	0.7	1.7	8.6	7.2	0.84	0.77	11.2	11.2	13.4	0.68	11.1	100.9	5.8					
	1.69	1.6	3.8	9.2	7.6	0.82	0.72	11.7	12.8	14.3	0.68	12.0	103.0	6.1					
	2.25	2.8	6.4	9.5	7.7	0.81	0.70	11.9	13.7	14.8	0.68	12.5	104.2	6.3					
100	1.13	0.7	1.7	7.8	6.8	0.87	0.84	10.6	9.3	13.4	0.68	11.1	100.9	5.8					
	1.69	1.6	3.7	8.3	7.1	0.85	0.79	11.0	10.5	13.4	0.68	11.1	100.9	5.8					
	2.25	2.7	6.2	8.6	7.2	0.84	0.77	11.2	11.2	13.4	0.68	11.1	100.9	5.8					
110	1.13	0.7	1.6	7.0	6.3	0.91	0.91	10.1	7.7	13.4	0.68	11.1	100.9	5.8					
	1.69	1.6	3.6	7.5	6.6	0.88	0.87	10.4	8.6	13.4	0.68	11.1	100.9	5.8					
	2.25	2.6	6.1	7.7	6.7	0.87	0.84	10.6	9.2	13.4	0.68	11.1	100.9	5.8					
120	1.13	0.7	1.6	6.3	6.0	0.96	0.99	9.6	6.4	13.4	0.68	11.1	100.9	5.8					
	1.69	1.5	3.5	6.7	6.2	0.93	0.94	9.9	7.1	13.4	0.68	11.1	100.9	5.8					
	2.25	2.6	5.9	6.9	6.3	0.91	0.92	10.0	7.5	13.4	0.68	11.1	100.9	5.8					

Interpolation is permissible, extrapolation is not.

All entering air conditions are 80°F DB and 67°F WB in cooling and 70°F DB in heating.

All performance data is based upon the lower voltage of dual voltage rated units.

See performance correction tables for operating conditions other than those listed above.

Table does not reflect corrections for Fan and Pump watts used is ISO-13256.

Operation below 40°F EWT is based upon 20% methanol antifreeze solution.

All performance data is based upon High speed.

Operation below 60°F requires optional insulated water/refrigerant circuit.

Operation in the darker shaded region is only permissible with use of CLM Modulating Water valve. At these conditions, water flow will be reduced in order to maintain a leaving water temperature of 70 °F

Operation in the lighter shaded areas may require antifreeze. See Performance Data Selection Notes for operation in the lighter shaded areas.

# Performance Data – TSM12 with ECM Motor

## 450 CFM Nominal Airflow

Performance capacities shown in thousands of Btuh

EWT °F	GPM	WPD		Cooling - EAT 80/67°F						Heating - EAT 70°F				
		PSI	FT	TC	SC	S/T	kW	HR	EER	HC	kW	HE	LAT	COP
20	1.50	2.3	5.3	Operation not recommended						6.8 0.77 4.2 83.9 2.6				
	2.25	4.7	10.8											
	3.00	7.8	18.0											
30	1.50	2.1	4.7	14.5	9.7	0.67	0.52	16.3	27.7	7.9	0.78	5.2	86.3	3.0
	2.25	4.3	9.9	14.2	9.3	0.65	0.50	15.9	28.7	8.3	0.79	5.6	87.1	3.1
	3.00	7.0	16.2	14.0	9.0	0.64	0.49	15.7	28.7	8.5	0.79	5.8	87.5	3.2
40	1.50	1.5	3.6	14.4	9.9	0.69	0.57	16.4	25.2	9.5	0.81	6.7	89.4	3.4
	2.25	3.1	7.3	14.5	9.8	0.67	0.53	16.3	27.2	10.0	0.81	7.2	90.4	3.6
	3.00	5.2	12.1	14.5	9.6	0.67	0.52	16.2	27.9	10.2	0.82	7.4	91.0	3.7
50	1.50	1.5	3.5	14.1	9.9	0.71	0.63	16.2	22.1	11.0	0.83	8.1	92.5	3.9
	2.25	3.1	7.1	14.4	10.0	0.69	0.59	16.4	24.5	11.6	0.84	8.7	93.7	4.1
	3.00	5.1	11.8	14.5	9.9	0.69	0.56	16.4	25.6	11.9	0.84	9.0	94.4	4.1
60	1.50	1.5	3.4	13.4	9.8	0.73	0.71	15.8	19.0	12.5	0.85	9.6	95.6	4.3
	2.25	3.0	6.9	13.9	9.9	0.71	0.65	16.1	21.3	13.2	0.86	10.3	97.1	4.5
	3.00	5.0	11.4	14.1	10.0	0.71	0.63	16.2	22.5	13.6	0.86	10.6	97.9	4.6
70	1.50	1.4	3.3	12.6	9.4	0.75	0.78	15.3	16.1	14.0	0.87	11.0	98.8	4.7
	2.25	2.9	6.7	13.2	9.7	0.73	0.73	15.7	18.2	14.8	0.88	11.8	100.4	4.9
	3.00	4.8	11.1	13.5	9.8	0.72	0.70	15.9	19.3	15.3	0.89	12.3	101.4	5.1
80	1.50	1.4	3.2	11.7	9.0	0.77	0.87	14.7	13.5	15.6	0.89	12.5	102.0	5.1
	2.25	2.8	6.5	12.4	9.3	0.75	0.81	15.1	15.3	16.5	0.90	13.5	103.9	5.4
	3.00	4.7	10.8	12.7	9.4	0.74	0.78	15.3	16.2	17.1	0.91	14.0	105.1	5.5
90	1.50	1.3	3.1	10.7	8.5	0.79	0.95	14.0	11.2	17.2	0.91	14.1	105.3	5.5
	2.25	2.8	6.4	11.4	8.8	0.77	0.90	14.4	12.7	18.3	0.93	15.2	107.6	5.8
	3.00	4.6	10.5	11.7	9.0	0.77	0.87	14.7	13.5	19.0	0.93	15.8	109.0	6.0
100	1.50	1.3	3.0	9.7	7.9	0.82	1.04	13.3	9.3	17.1	0.91	14.0	105.1	5.5
	2.25	2.7	6.2	10.4	8.3	0.80	0.99	13.7	10.5	17.1	0.91	14.0	105.1	5.5
	3.00	4.5	10.3	10.7	8.4	0.79	0.96	14.0	11.1	17.1	0.91	14.0	105.1	5.5
110	1.50	1.3	2.9	8.7	7.4	0.85	1.13	12.6	7.7	17.1	0.91	14.0	105.1	5.5
	2.25	2.6	6.1	9.3	7.7	0.83	1.08	13.0	8.6	17.1	0.91	14.0	105.1	5.5
	3.00	4.4	10.1	9.6	7.9	0.82	1.05	13.2	9.2	17.1	0.91	14.0	105.1	5.5
120	1.50	1.2	2.8	7.8	6.9	0.88	1.22	12.0	6.4	17.1	0.91	14.0	105.1	5.5
	2.25	2.6	5.9	8.3	7.2	0.86	1.17	12.3	7.1	17.1	0.91	14.0	105.1	5.5
	3.00	4.3	10.0	8.6	7.3	0.85	1.15	12.5	7.5	17.1	0.91	14.0	105.1	5.5

Interpolation is permissible, extrapolation is not.

All entering air conditions are 80°F DB and 67°F WB in cooling and 70°F DB in heating.

All performance data is based upon the lower voltage of dual voltage rated units.

See performance correction tables for operating conditions other than those listed above.

Table does not reflect corrections for Fan and Pump watts used is ISO-13256.

Operation below 40°F EWT is based upon 20% methanol antifreeze solution.

All performance data is based upon High speed.

Operation below 60°F requires optional insulated water/refrigerant circuit.

Operation in the darker shaded region is only permissible with use of CLM Modulating Water valve. At these conditions, water flow will be reduced in order to maintain a leaving water temperature of 70 °F

Operation in the lighter shaded areas may require antifreeze. See Performance Data Selection Notes for operation in the lighter shaded areas.

# Performance Data – TSM15 with ECM Motor

## 600 CFM Nominal Airflow

Performance capacities shown in thousands of Btuh

EWT °F	GPM	WPD		Cooling - EAT 80/67°F						Heating - EAT 70°F									
		PSI	FT	TC	SC	S/T	kW	HR	EER	HC	kW	HE	LAT	COP					
20	1.88	0.5	1.2	Operation not recommended						8.5	0.87	5.5	83.0	2.9					
	2.81	1.6	3.8																
	3.75	2.7	6.3																
30	1.88	0.4	1.0	18.9	13.8	0.73	0.52	20.6	35.9	9.7	0.89	6.7	85.0	3.2					
	2.81	1.4	3.2	18.4	12.8	0.70	0.49	20.1	37.7	10.2	0.90	7.1	85.7	3.3					
	3.75	2.3	5.4	18.1	12.2	0.67	0.48	19.7	37.7	10.5	0.90	7.4	86.1	3.4					
40	1.88	0.3	0.7	18.8	14.4	0.76	0.59	20.8	31.7	11.6	0.92	8.5	87.9	3.7					
	2.81	0.9	2.1	18.9	14.0	0.74	0.54	20.7	35.0	12.3	0.93	9.1	88.9	3.9					
	3.75	1.5	3.5	18.8	13.7	0.73	0.52	20.6	36.3	12.6	0.93	9.4	89.4	4.0					
50	1.88	0.3	0.6	18.2	14.2	0.78	0.68	20.5	26.9	13.6	0.95	10.4	90.9	4.2					
	2.81	0.9	2.0	18.7	14.4	0.77	0.61	20.8	30.5	14.4	0.95	11.1	92.2	4.4					
	3.75	1.4	3.3	18.8	14.3	0.76	0.58	20.8	32.3	14.8	0.96	11.6	92.9	4.5					
60	1.88	0.3	0.6	17.3	13.7	0.80	0.77	19.9	22.4	15.6	0.97	12.3	94.0	4.7					
	2.81	0.8	1.9	18.0	14.1	0.79	0.70	20.4	25.7	16.6	0.98	13.2	95.5	5.0					
	3.75	1.4	3.2	18.3	14.3	0.78	0.67	20.6	27.5	17.1	0.98	13.8	96.3	5.1					
70	1.88	0.3	0.6	16.1	13.0	0.81	0.88	19.1	18.3	17.6	0.99	14.2	97.1	5.2					
	2.81	0.8	1.8	16.9	13.5	0.80	0.80	19.7	21.1	18.7	1.00	15.3	98.8	5.5					
	3.75	1.3	3.0	17.3	13.8	0.79	0.76	19.9	22.7	19.4	1.00	15.9	99.8	5.7					
80	1.88	0.2	0.6	14.8	12.1	0.82	0.99	18.2	14.9	19.6	1.00	16.2	100.2	5.7					
	2.81	0.7	1.7	15.7	12.7	0.81	0.91	18.8	17.2	20.9	1.01	17.4	102.1	6.0					
	3.75	1.3	2.9	16.1	13.0	0.81	0.87	19.1	18.5	21.5	1.02	18.1	103.2	6.2					
90	1.88	1.1	2.6	13.5	11.3	0.84	1.11	17.3	12.1	21.6	1.02	18.1	103.2	6.2					
	2.81	2.2	5.1	14.3	11.8	0.82	1.03	17.9	13.9	22.9	1.02	19.4	105.3	6.6					
	3.75	3.6	8.3	14.8	12.1	0.82	0.99	18.2	14.9	23.6	1.03	20.1	106.4	6.7					
100	1.88	1.1	2.5	12.2	10.6	0.86	1.23	16.4	9.9	21.6	1.02	18.1	103.2	6.2					
	2.81	2.1	4.9	13.0	11.0	0.85	1.16	16.9	11.2	21.6	1.02	18.1	103.2	6.2					
	3.75	3.5	8.0	13.4	11.2	0.84	1.12	17.2	12.0	21.6	1.02	18.1	103.2	6.2					
110	1.88	1.0	2.4	11.1	10.1	0.91	1.36	15.7	8.1	21.6	1.02	18.1	103.2	6.2					
	2.81	2.0	4.7	11.7	10.3	0.88	1.29	16.1	9.1	21.6	1.02	18.1	103.2	6.2					
	3.75	3.3	7.7	12.1	10.5	0.87	1.25	16.3	9.7	21.6	1.02	18.1	103.2	6.2					
120	1.88	1.0	2.3	10.2	9.9	0.97	1.49	15.3	6.8	21.6	1.02	18.1	103.2	6.2					
	2.81	2.0	4.5	10.6	9.9	0.93	1.42	15.5	7.5	21.6	1.02	18.1	103.2	6.2					
	3.75	3.2	7.4	10.9	10.0	0.92	1.38	15.6	7.9	21.6	1.02	18.1	103.2	6.2					

Interpolation is permissible, extrapolation is not.

All entering air conditions are 80°F DB and 67°F WB in cooling and 70°F DB in heating.

All performance data is based upon the lower voltage of dual voltage rated units.

See performance correction tables for operating conditions other than those listed above.

Table does not reflect corrections for Fan and Pump watts used is ISO-13256.

Operation below 40°F EWT is based upon 20% methanol antifreeze solution.

All performance data is based upon High speed.

Operation below 60°F requires optional insulated water/refrigerant circuit.

Operation in the darker shaded region is only permissible with use of CLM Modulating Water valve. At these conditions, water flow will be reduced in order to maintain a leaving water temperature of 70 °F

Operation in the lighter shaded areas may require antifreeze. See Performance Data Selection Notes for operation in the lighter shaded areas.

# Performance Data – TSM18 with ECM Motor

## 700 CFM Nominal Airflow

Performance capacities shown in thousands of Btu/h

EWT °F	GPM	WPD		Cooling - EAT 80/67°F						Heating - EAT 70°F				
		PSI	FT	TC	SC	S/T	kW	HR	EER	HC	kW	HE	LAT	COP
20	2.25	0.8	1.8	Operation not recommended						9.3 1.05 5.7 82.2 2.6				
	3.38	1.9	4.4											
	4.50	3.3	7.7											
30	2.25	0.6	1.4	20.4	14.1	0.69	0.70	22.8	29.1	11.1	1.08	7.4	84.7	3.0
	3.38	1.6	3.7	20.2	13.6	0.67	0.66	22.5	30.8	11.7	1.09	8.0	85.4	3.1
	4.50	2.8	6.6	20.0	13.2	0.66	0.64	22.2	31.4	12.0	1.10	8.3	85.9	3.2
40	2.25	0.5	1.1	20.2	14.3	0.71	0.78	22.9	25.8	13.5	1.12	9.6	87.8	3.5
	3.38	1.2	2.7	20.4	14.2	0.70	0.73	22.9	28.1	14.2	1.13	10.3	88.7	3.7
	4.50	2.0	4.7	20.4	14.1	0.69	0.70	22.8	29.2	14.6	1.14	10.7	89.2	3.8
50	2.25	0.4	1.0	19.5	14.1	0.72	0.88	22.5	22.2	15.7	1.15	11.8	90.7	4.0
	3.38	1.1	2.6	20.0	14.3	0.71	0.81	22.8	24.7	16.5	1.16	12.5	91.8	4.2
	4.50	2.0	4.5	20.2	14.3	0.71	0.78	22.9	25.9	16.9	1.17	12.9	92.3	4.3
60	2.25	0.4	1.0	18.5	13.7	0.74	0.98	21.8	18.8	17.8	1.18	13.8	93.5	4.4
	3.38	1.1	2.5	19.2	14.0	0.73	0.91	22.3	21.1	18.7	1.19	14.6	94.6	4.6
	4.50	1.9	4.3	19.5	14.1	0.72	0.88	22.5	22.3	19.1	1.19	15.1	95.3	4.7
70	2.25	0.4	0.9	17.2	13.0	0.76	1.10	21.0	15.6	19.8	1.20	15.7	96.1	4.8
	3.38	1.0	2.4	18.0	13.5	0.75	1.02	21.5	17.6	20.7	1.21	16.6	97.4	5.0
	4.50	1.8	4.1	18.5	13.7	0.74	0.98	21.8	18.7	21.3	1.22	17.1	98.1	5.1
80	2.25	0.4	0.9	15.8	12.3	0.78	1.23	20.0	12.8	21.7	1.22	17.5	98.6	5.2
	3.38	1.0	2.2	16.7	12.8	0.77	1.15	20.6	14.5	22.7	1.23	18.5	100.0	5.4
	4.50	1.7	4.0	17.1	13.0	0.76	1.11	20.9	15.5	23.3	1.24	19.1	100.8	5.5
90	2.25	0.4	0.8	14.3	11.6	0.81	1.37	19.0	10.4	23.6	1.25	19.3	101.1	5.5
	3.38	0.9	2.1	15.2	12.0	0.79	1.29	19.6	11.8	24.7	1.27	20.4	102.6	5.7
	4.50	1.6	3.8	15.6	12.3	0.78	1.24	19.9	12.6	25.4	1.28	21.0	103.5	5.8
100	2.25	0.3	0.8	12.8	10.9	0.85	1.52	18.0	8.4	22.7	1.23	18.5	100.0	5.4
	3.38	0.9	2.1	13.6	11.3	0.83	1.44	18.5	9.5	22.7	1.23	18.5	100.0	5.4
	4.50	1.6	3.7	14.1	11.5	0.82	1.39	18.8	10.1	22.7	1.23	18.5	100.0	5.4
110	2.25	0.3	0.7	11.3	10.2	0.90	1.69	17.1	6.7	22.7	1.23	18.5	100.0	5.4
	3.38	0.9	2.0	12.1	10.6	0.87	1.60	17.5	7.6	22.7	1.23	18.5	100.0	5.4
	4.50	1.5	3.6	12.5	10.7	0.86	1.55	17.8	8.0	22.7	1.23	18.5	100.0	5.4
120	2.25	0.3	0.7	10.0	9.8	0.97	1.86	16.4	5.4	22.7	1.23	18.5	100.0	5.4
	3.38	0.8	1.9	10.7	10.0	0.94	1.77	16.7	6.0	22.7	1.23	18.5	100.0	5.4
	4.50	1.5	3.4	11.0	10.1	0.92	1.73	16.9	6.4	22.7	1.23	18.5	100.0	5.4

Interpolation is permissible, extrapolation is not.

All entering air conditions are 80°F DB and 67°F WB in cooling and 70°F DB in heating.

All performance data is based upon the lower voltage of dual voltage rated units.

See performance correction tables for operating conditions other than those listed above.

Table does not reflect corrections for Fan and Pump watts used is ISO-13256.

Operation below 40°F EWT is based upon 20% methanol antifreeze solution.

All performance data is based upon High speed.

Operation below 60°F requires optional insulated water/refrigerant circuit.

Operation in the darker shaded region is only permissible with use of CLM Modulating Water valve. At these conditions, water flow will be reduced in order to maintain a leaving water temperature of 70 °F

Operation in the lighter shaded areas may require antifreeze. See Performance Data Selection Notes for operation in the lighter shaded areas.

# Performance Data – TSM24 with ECM Motor

## 850 CFM Nominal Airflow

Performance capacities shown in thousands of Btuh

EWT °F	GPM	WPD		Cooling - EAT 80/67°F						Heating - EAT 70°F				
		PSI	FT	TC	SC	S/T	kW	HR	EER	HC	kW	HE	LAT	COP
20	3.00	1.2	2.8	Operation not recommended						15.0 1.62 9.4 87.3 2.7				
	4.50	2.5	5.9											
	6.00	4.1	9.6											
30	3.00	1.0	2.4	31.0	21.6	0.70	1.08	34.7	28.8	17.1	1.66	11.5	89.8	3.0
	4.50	2.1	5.0	31.2	21.7	0.70	0.99	34.6	31.6	18.0	1.68	12.3	90.8	3.2
	6.00	3.6	8.2	31.2	21.7	0.70	0.95	34.4	33.0	18.6	1.69	12.8	91.4	3.2
40	3.00	0.8	1.7	30.4	21.3	0.70	1.20	34.5	25.4	20.4	1.71	14.5	93.5	3.5
	4.50	1.6	3.6	30.9	21.6	0.70	1.10	34.7	28.1	21.5	1.73	15.6	94.8	3.6
	6.00	2.5	5.9	31.1	21.7	0.70	1.06	34.7	29.4	22.1	1.74	16.2	95.6	3.7
50	3.00	0.7	1.7	29.5	20.9	0.71	1.33	34.0	22.2	23.6	1.77	17.5	97.2	3.9
	4.50	1.5	3.4	30.3	21.2	0.70	1.22	34.4	24.7	24.9	1.79	18.8	98.8	4.1
	6.00	2.4	5.6	30.6	21.4	0.70	1.17	34.6	26.0	25.7	1.80	19.6	99.7	4.2
60	3.00	0.7	1.6	28.3	20.3	0.72	1.48	33.4	19.1	26.8	1.82	20.6	100.9	4.3
	4.50	1.4	3.3	29.3	20.8	0.71	1.36	33.9	21.5	28.3	1.84	22.1	102.7	4.5
	6.00	2.3	5.4	29.7	21.0	0.71	1.31	34.1	22.7	29.2	1.86	22.9	103.7	4.6
70	3.00	0.7	1.5	26.9	19.7	0.73	1.65	32.6	16.3	29.9	1.87	23.5	104.5	4.7
	4.50	1.4	3.1	28.0	20.2	0.72	1.52	33.2	18.4	31.7	1.91	25.2	106.6	4.9
	6.00	2.2	5.2	28.5	20.4	0.72	1.46	33.5	19.5	32.7	1.93	26.1	107.7	5.0
80	3.00	0.6	1.4	25.4	19.0	0.75	1.85	31.7	13.7	33.0	1.93	26.4	108.1	5.0
	4.50	1.3	3.0	26.6	19.5	0.73	1.70	32.4	15.6	34.9	1.98	28.2	110.3	5.2
	6.00	2.1	5.0	27.1	19.8	0.73	1.63	32.7	16.6	36.0	2.01	29.1	111.6	5.3
90	3.00	0.6	1.4	23.7	18.2	0.77	2.08	30.8	11.4	36.0	2.01	29.1	111.6	5.3
	4.50	1.2	2.9	24.9	18.7	0.75	1.91	31.5	13.0	38.1	2.07	31.0	113.9	5.4
	6.00	2.1	4.8	25.5	19.0	0.74	1.83	31.8	13.9	39.2	2.11	32.0	115.2	5.4
100	3.00	0.6	1.3	22.0	17.3	0.79	2.34	30.0	9.4	36.0	2.01	29.1	111.6	5.3
	4.50	1.2	2.8	23.2	17.9	0.77	2.15	30.6	10.8	36.0	2.01	29.1	111.6	5.3
	6.00	2.0	4.6	23.8	18.2	0.76	2.07	30.9	11.5	36.0	2.01	29.1	111.6	5.3
110	3.00	0.6	1.3	20.2	16.5	0.81	2.64	29.3	7.7	36.0	2.01	29.1	111.6	5.3
	4.50	1.2	2.7	21.4	17.1	0.80	2.43	29.7	8.8	36.0	2.01	29.1	111.6	5.3
	6.00	1.9	4.5	22.0	17.4	0.79	2.33	30.0	9.4	36.0	2.01	29.1	111.6	5.3
120	3.00	0.5	1.2	18.5	15.6	0.84	2.99	28.7	6.2	36.0	2.01	29.1	111.6	5.3
	4.50	1.1	2.6	19.6	16.2	0.82	2.76	29.0	7.1	36.0	2.01	29.1	111.6	5.3
	6.00	1.9	4.4	20.2	16.5	0.81	2.65	29.3	7.6	36.0	2.01	29.1	111.6	5.3

Interpolation is permissible, extrapolation is not.

All entering air conditions are 80°F DB and 67°F WB in cooling and 70°F DB in heating.

All performance data is based upon the lower voltage of dual voltage rated units.

See performance correction tables for operating conditions other than those listed above.

Table does not reflect corrections for Fan and Pump watts used is ISO-13256.

Operation below 40°F EWT is based upon 20% methanol antifreeze solution.

All performance data is based upon High speed.

Operation below 60°F requires optional insulated water/refrigerant circuit.

Operation in the darker shaded region is only permissible with use of CLM Modulating Water valve. At these conditions, water flow will be reduced in order to maintain a leaving water temperature of 70 °F

Operation in the lighter shaded areas may require antifreeze. See Performance Data Selection Notes for operation in the lighter shaded areas.



# Performance Data – TSM30 with ECM Motor

## 1,000 CFM Nominal Airflow

Performance capacities shown in thousands of Btuh

EWT °F	GPM	WPD		Cooling - EAT 80/67°F						Heating - EAT 70°F				
		PSI	FT	TC	SC	S/T	kW	HR	EER	HC	kW	HE	LAT	COP
20	3.75	1.5	3.5	Operation not recommended						16.4 1.71 10.5 85.1 2.8				
	5.63	3.3	7.5											
	7.50	5.4	12.6											
30	3.75	1.3	3.1	33.7	23.4	0.70	1.10	37.5	30.5	18.6	1.72	12.7	87.2	3.2
	5.63	2.9	6.6	33.3	22.8	0.69	1.03	36.8	32.4	19.4	1.73	13.5	87.9	3.3
	7.50	5.0	11.6	33.0	22.4	0.68	0.99	36.4	33.2	19.8	1.73	13.9	88.3	3.4
40	3.75	1.0	2.3	33.6	23.7	0.71	1.22	37.8	27.4	21.7	1.75	15.7	90.0	3.6
	5.63	2.1	4.9	33.7	23.6	0.70	1.14	37.6	29.6	22.6	1.76	16.7	90.9	3.8
	7.50	3.5	8.0	33.7	23.4	0.70	1.10	37.4	30.6	23.2	1.76	17.2	91.4	3.9
50	3.75	1.0	2.2	32.9	23.5	0.71	1.36	37.5	24.2	24.8	1.78	18.7	92.9	4.1
	5.63	2.0	4.7	33.4	23.7	0.71	1.26	37.8	26.4	25.9	1.80	19.8	93.9	4.2
	7.50	3.4	7.9	33.6	23.7	0.71	1.22	37.8	27.6	26.5	1.81	20.4	94.5	4.3
60	3.75	0.9	2.1	31.7	22.8	0.72	1.51	36.9	20.9	27.8	1.83	21.6	95.7	4.5
	5.63	2.0	4.5	32.6	23.3	0.72	1.41	37.4	23.2	29.1	1.85	22.8	96.9	4.6
	7.50	3.3	7.7	32.9	23.5	0.71	1.36	37.5	24.3	29.8	1.86	23.5	97.6	4.7
70	3.75	0.9	2.0	30.2	21.9	0.73	1.69	35.9	17.8	30.9	1.88	24.5	98.5	4.8
	5.63	1.9	4.4	31.2	22.5	0.72	1.57	36.6	19.9	32.3	1.91	25.8	99.9	5.0
	7.50	3.2	7.5	31.7	22.8	0.72	1.51	36.9	21.0	33.1	1.93	26.6	100.6	5.0
80	3.75	0.9	2.0	28.3	20.9	0.74	1.89	34.8	15.0	33.9	1.95	27.3	101.3	5.1
	5.63	1.8	4.2	29.5	21.6	0.73	1.76	35.5	16.8	35.6	1.99	28.8	102.8	5.2
	7.50	3.2	7.3	30.1	21.9	0.73	1.69	35.9	17.8	36.4	2.01	29.6	103.7	5.3
90	3.75	0.8	1.9	26.3	19.9	0.76	2.13	33.6	12.4	37.0	2.02	30.1	104.1	5.4
	5.63	1.8	4.1	27.6	20.6	0.75	1.98	34.3	13.9	38.8	2.07	31.7	105.8	5.5
	7.50	3.1	7.1	28.2	20.9	0.74	1.91	34.7	14.8	39.7	2.10	32.6	106.7	5.5
100	3.75	0.8	1.8	24.2	18.9	0.78	2.40	32.3	10.1	35.6	1.99	28.8	102.8	5.2
	5.63	1.7	3.9	25.4	19.5	0.77	2.23	33.1	11.4	35.6	1.99	28.8	102.8	5.2
	7.50	3.0	6.8	26.1	19.8	0.76	2.15	33.4	12.1	35.6	1.99	28.8	102.8	5.2
110	3.75	0.8	1.8	22.0	18.0	0.82	2.71	31.2	8.1	35.6	1.99	28.8	102.8	5.2
	5.63	1.7	3.8	23.2	18.5	0.80	2.52	31.8	9.2	35.6	1.99	28.8	102.8	5.2
	7.50	2.8	6.6	23.9	18.8	0.79	2.43	32.2	9.8	35.6	1.99	28.8	102.8	5.2
120	3.75	0.7	1.7	19.8	17.1	0.87	3.06	30.2	6.5	35.6	1.99	28.8	102.8	5.2
	5.63	1.6	3.7	21.0	17.6	0.84	2.86	30.7	7.3	35.6	1.99	28.8	102.8	5.2
	7.50	2.7	6.3	21.6	17.8	0.82	2.76	31.0	7.8	35.6	1.99	28.8	102.8	5.2

Interpolation is permissible, extrapolation is not.

All entering air conditions are 80°F DB and 67°F WB in cooling and 70°F DB in heating.

All performance data is based upon the lower voltage of dual voltage rated units.

See performance correction tables for operating conditions other than those listed above.

Table does not reflect corrections for Fan and Pump watts used is ISO-13256.

Operation below 40°F EWT is based upon 20% methanol antifreeze solution.

All performance data is based upon High speed.

Operation below 60°F requires optional insulated water/refrigerant circuit.

Operation in the darker shaded region is only permissible with use of CLM Modulating Water valve. At these conditions, water flow will be reduced in order to maintain a leaving water temperature of 70 °F

Operation in the lighter shaded areas may require antifreeze. See Performance Data Selection Notes for operation in the lighter shaded areas.

# Performance Data – TSM36 with ECM Motor

## 1,200 CFM Nominal Airflow

Performance capacities shown in thousands of Btuh

EWT °F	WPD			Cooling - EAT 80/67°F						Heating - EAT 70°F									
	GPM	PSI	FT	TC	SC	S/T	kW	HR	EER	HC	kW	HE	LAT	COP					
20	4.50	2.2	5.1	Operation not recommended						20.8	2.05	13.8	86.0	3.0					
	6.75	4.5	10.3																
	9.00	7.2	16.7																
30	4.50	1.8	4.2	40.9	28.2	0.69	1.44	45.9	28.5	23.1	2.09	16.0	87.8	3.2					
	6.75	3.6	8.4	40.0	27.4	0.68	1.34	44.6	29.8	24.0	2.10	16.8	88.5	3.3					
	9.00	5.9	13.6	39.3	26.8	0.68	1.30	43.8	30.3	24.5	2.11	17.3	88.8	3.4					
40	4.50	1.5	3.4	41.2	28.6	0.69	1.59	46.6	25.9	26.7	2.15	19.4	90.6	3.6					
	6.75	2.9	6.8	41.1	28.4	0.69	1.48	46.2	27.7	27.9	2.17	20.5	91.5	3.8					
	9.00	4.8	11.0	40.9	28.1	0.69	1.43	45.8	28.5	28.5	2.18	21.1	91.9	3.8					
50	4.50	1.4	3.2	40.4	28.4	0.70	1.76	46.4	23.0	30.5	2.22	23.0	93.5	4.0					
	6.75	2.8	6.4	41.0	28.6	0.70	1.64	46.6	25.0	31.9	2.24	24.3	94.6	4.2					
	9.00	4.5	10.4	41.2	28.6	0.69	1.58	46.6	26.0	32.7	2.26	25.0	95.2	4.2					
60	4.50	1.3	3.1	38.9	27.7	0.71	1.95	45.6	19.9	34.4	2.29	26.6	96.5	4.4					
	6.75	2.6	6.1	40.0	28.2	0.71	1.81	46.2	22.1	35.9	2.32	28.0	97.7	4.5					
	9.00	4.3	9.9	40.5	28.4	0.70	1.75	46.4	23.1	36.8	2.34	28.8	98.3	4.6					
70	4.50	1.3	2.9	36.9	26.7	0.72	2.17	44.3	17.0	38.1	2.36	30.0	99.3	4.7					
	6.75	2.5	5.8	38.3	27.4	0.72	2.02	45.2	19.0	39.7	2.39	31.5	100.6	4.9					
	9.00	4.0	9.3	39.0	27.7	0.71	1.94	45.6	20.0	40.6	2.41	32.3	101.2	4.9					
80	4.50	1.2	2.7	34.6	25.4	0.74	2.44	42.9	14.2	41.4	2.43	33.2	101.9	5.0					
	6.75	2.3	5.4	36.1	26.3	0.73	2.26	43.8	16.0	43.0	2.46	34.6	103.1	5.1					
	9.00	3.8	8.8	36.9	26.7	0.72	2.17	44.3	17.0	43.8	2.48	35.3	103.7	5.2					
90	4.50	1.1	2.6	32.1	24.1	0.75	2.74	41.4	11.7	44.3	2.49	35.8	104.1	5.2					
	6.75	2.2	5.1	33.7	25.0	0.74	2.54	42.3	13.2	45.6	2.53	37.0	105.1	5.3					
	9.00	3.6	8.3	34.5	25.4	0.74	2.45	42.8	14.1	46.1	2.54	37.5	105.5	5.3					
100	4.50	1.1	2.5	29.5	22.6	0.77	3.11	40.1	9.5	43.0	2.46	34.6	103.1	5.1					
	6.75	2.1	4.9	31.1	23.5	0.76	2.88	40.9	10.8	43.0	2.46	34.6	103.1	5.1					
	9.00	3.5	8.0	31.9	24.0	0.75	2.77	41.3	11.5	43.0	2.46	34.6	103.1	5.1					
110	4.50	1.0	2.4	27.1	21.2	0.78	3.54	39.2	7.7	43.0	2.46	34.6	103.1	5.1					
	6.75	2.0	4.7	28.5	22.0	0.77	3.27	39.7	8.7	43.0	2.46	34.6	103.1	5.1					
	9.00	3.3	7.7	29.3	22.5	0.77	3.15	40.0	9.3	43.0	2.46	34.6	103.1	5.1					
120	4.50	1.0	2.3	24.9	20.1	0.80	4.05	38.8	6.2	43.0	2.46	34.6	103.1	5.1					
	6.75	2.0	4.5	26.2	20.7	0.79	3.74	38.9	7.0	43.0	2.46	34.6	103.1	5.1					
	9.00	3.2	7.4	26.8	21.1	0.79	3.60	39.1	7.5	43.0	2.46	34.6	103.1	5.1					

Interpolation is permissible, extrapolation is not.  
 All entering air conditions are 80°F DB and 67°F WB in cooling and 70°F DB in heating.  
 All performance data is based upon the lower voltage of dual voltage rated units.  
 See performance correction tables for operating conditions other than those listed above.  
 Table does not reflect corrections for Fan and Pump watts used is ISO-13256.  
 Operation below 40°F EWT is based upon 20% methanol antifreeze solution.  
 All performance data is based upon High speed.  
 Operation below 60°F requires optional insulated water/refrigerant circuit.  
 Operation in the darker shaded region is only permissible with use of CLM Modulating Water valve. At these conditions, water flow will be reduced in order to maintain a leaving water temperature of 70 °F  
 Operation in the lighter shaded areas may require antifreeze. See Performance Data Selection Notes for operation in the lighter shaded areas.

# Air Flow Correction Table and Water Pressure Drop Adders

## Air Flow Correction Table

Airflow % of Nominal (Rated) SCFM	Cooling				Heating		
	Total Capacity	Sensible Capacity	Power	Heat of Rejection	Heating Capacity	Power	Heat of Extraction
70	0.921	0.8	0.969	0.943	0.942	1.077	0.934
75	0.934	0.833	0.974	0.952	0.952	1.062	0.947
80	0.946	0.866	0.979	0.961	0.961	1.048	0.958
85	0.958	0.899	0.985	0.97	0.971	1.035	0.969
90	0.971	0.932	0.99	0.979	0.980	1.023	0.979
95	0.985	0.966	0.995	0.989	0.990	1.011	0.989
100	1.000	1.000	1.000	1.000	1.000	1.000	1.000
105	1.017	1.035	1.005	1.013	1.010	0.989	1.011

## Motorized Water Valve

Unit Size	N.O./N.C. Motorized Water Valves (MWV)		Modulating Valve	
	Cv	Max Close-Off Pressure	Cv	Max Close-Off Pressure
	gpm/psig	psig	gpm/psig	psig
09	4.9	125	3.0	200
12	4.9	125	3.0	200
15	10.3	125	4.7	200
18	10.3	125	4.7	200
24	10.3	125	7.4	200
30	10.3	125	7.4	200
36	10.3	125	7.4	200

# Antifreeze Correction Table

EWT	Antifreeze Type	Antifreeze %	Cooling			Heating		WPD
			Total Cap	Sensible Cap	Watts	Total Cap	Watts	
90	Water	0%	1	1	1	1	1	1
	Ethanol	5%	0.998	0.998	1.002	0.996	0.999	1.025
		10%	0.996	0.996	1.003	0.991	0.997	1.048
		15%	0.994	0.994	1.005	0.987	0.996	1.098
		20%	0.991	0.991	1.006	0.982	0.994	1.142
		25%	0.986	0.986	1.009	0.972	0.991	1.207
		30%	0.981	0.981	1.012	0.962	0.988	1.265
		35%	0.977	0.977	1.015	0.953	0.985	1.312
		40%	0.972	0.972	1.018	0.943	0.982	1.37
		45%	0.966	0.966	1.023	0.931	0.978	1.431
	50%	0.959	0.959	1.027	0.918	0.974	1.494	
	Ethylene Glycol	5%	0.998	0.998	1.002	0.996	0.999	1.021
		10%	0.996	0.996	1.003	0.991	0.997	1.04
		15%	0.994	0.994	1.004	0.987	0.996	1.079
		20%	0.991	0.991	1.005	0.982	0.995	1.114
		25%	0.988	0.988	1.008	0.976	0.993	1.146
		30%	0.985	0.985	1.01	0.969	0.99	1.175
		35%	0.982	0.982	1.012	0.963	0.988	1.208
		40%	0.979	0.979	1.014	0.956	0.986	1.243
		45%	0.976	0.976	1.016	0.95	0.984	1.278
	50%	0.972	0.972	1.018	0.943	0.982	1.314	
	Methanol	5%	0.997	0.997	1.002	0.993	0.998	1.039
		10%	0.993	0.993	1.004	0.986	0.996	1.075
		15%	0.99	0.99	1.007	0.979	0.994	1.116
		20%	0.986	0.986	1.009	0.972	0.991	1.154
		25%	0.982	0.982	1.012	0.964	0.989	1.189
		30%	0.978	0.978	1.014	0.955	0.986	1.221
		35%	0.974	0.974	1.017	0.947	0.984	1.267
		40%	0.97	0.97	1.02	0.939	0.981	1.31
		45%	0.966	0.966	1.023	0.93	0.978	1.353
	50%	0.961	0.961	1.026	0.92	0.975	1.398	
	Propylene Glycol	5%	0.995	0.995	1.003	0.99	0.997	1.065
		10%	0.99	0.99	1.006	0.98	0.994	1.119
		15%	0.986	0.986	1.009	0.971	0.991	1.152
		20%	0.981	0.981	1.012	0.962	0.988	1.182
		25%	0.978	0.978	1.014	0.956	0.986	1.227
		30%	0.975	0.975	1.016	0.95	0.984	1.267
		35%	0.972	0.972	1.018	0.944	0.982	1.312
		40%	0.969	0.969	1.02	0.938	0.98	1.356
		45%	0.965	0.965	1.023	0.929	0.977	1.402
	50%	0.96	0.96	1.026	0.919	0.974	1.45	

Table Continued on Next Page

# Antifreeze Correction Table

Table Continued from Previous Page

EWT	Antifreeze Type	Antifreeze %	Cooling			Heating		WPD
			Total Cap	Sensible Cap	Watts	Total Cap	Watts	
30	Water	0%	1	1	1	1	1	1
	Ethanol	5%	0.991	0.991	1.006	0.981	0.994	1.14
		10%	0.981	0.981	1.012	0.961	0.988	1.242
		15%	0.973	0.973	1.018	0.944	0.983	1.295
		20%	0.964	0.964	1.024	0.927	0.977	1.343
		25%	0.959	0.959	1.028	0.917	0.974	1.363
		30%	0.954	0.954	1.031	0.907	0.97	1.383
		35%	0.949	0.949	1.035	0.897	0.967	1.468
		40%	0.944	0.944	1.038	0.887	0.964	1.523
		45%	0.94	0.94	1.041	0.88	0.962	1.58
	50%	0.936	0.936	1.043	0.872	0.959	1.639	
	Ethylene Glycol	5%	0.997	0.997	1.002	0.993	0.998	1.04
		10%	0.993	0.993	1.004	0.986	0.996	1.075
		15%	0.99	0.99	1.006	0.98	0.994	1.122
		20%	0.987	0.987	1.008	0.973	0.992	1.163
		25%	0.983	0.983	1.011	0.966	0.99	1.195
		30%	0.979	0.979	1.013	0.958	0.987	1.225
		35%	0.976	0.976	1.016	0.951	0.985	1.279
		40%	0.972	0.972	1.018	0.943	0.982	1.324
		45%	0.969	0.969	1.021	0.937	0.98	1.371
	50%	0.966	0.966	1.023	0.93	0.978	1.419	
	Methanol	5%	0.995	0.995	1.004	0.989	0.997	1.069
		10%	0.989	0.989	1.007	0.978	0.993	1.127
		15%	0.984	0.984	1.011	0.968	0.99	1.164
		20%	0.979	0.979	1.014	0.957	0.986	1.197
		25%	0.975	0.975	1.017	0.949	0.984	1.216
		30%	0.971	0.971	1.019	0.941	0.981	1.235
		35%	0.967	0.967	1.022	0.933	0.979	1.286
		40%	0.963	0.963	1.025	0.924	0.976	1.323
		45%	0.959	0.959	1.028	0.917	0.974	1.36
	50%	0.955	0.955	1.03	0.91	0.971	1.399	
	Propylene Glycol	5%	0.995	0.995	1.004	0.989	0.997	1.071
		10%	0.989	0.989	1.007	0.978	0.993	1.13
		15%	0.985	0.985	1.01	0.968	0.99	1.206
		20%	0.98	0.98	1.013	0.958	0.987	1.27
		25%	0.974	0.974	1.017	0.947	0.983	1.359
		30%	0.968	0.968	1.021	0.935	0.979	1.433
		35%	0.963	0.963	1.025	0.924	0.976	1.522
		40%	0.957	0.957	1.029	0.913	0.972	1.614
		45%	0.949	0.949	1.034	0.898	0.967	1.712
	50%	0.941	0.941	1.039	0.882	0.962	1.816	

# Performance Data – Correction Tables

## Entering Air Correction Table - Heating

Heating			
Entering Air DB°F	Heating Capacity	Power	Heat of Extraction
45	1.109	0.763	1.183
50	1.088	0.809	1.146
55	1.067	0.854	1.110
60	1.045	0.901	1.075
65	1.024	0.948	1.039
68	1.010	0.979	1.015
70	1.000	1.000	1.000
75	0.984	1.046	0.965
80	0.956	1.099	0.924

## Entering Air Correction Table - Cooling

Cooling											
Ent. Air WB °F	Total Capacity	Sensible Capacity-Entering Air Dry Bulb, °F								Power	Heat of Rejection
		65	70	75	80	80.6	85	90	95		
45	0.557	*	*	*	*	*	*	*	*	0.986	0.672
50	0.658	1.100	*	*	*	*	*	*	*	0.989	0.747
55	0.758	0.861	1.091	*	*	*	*	*	*	0.992	0.821
60	0.859	0.623	0.854	1.091	1.325	1.383	*	*	*	0.996	0.896
65	0.960		0.617	0.857	1.093	1.151	1.326	*	*	0.999	0.970
66.2	0.984		0.561	0.801	1.037	1.095	1.270	1.521	*	1.000	0.988
67	1.000		0.523	0.763	1.000	1.058	1.232	1.482	*	1.000	1.000
70	1.060			0.623	0.861	0.919	1.090	1.339	1.563	1.002	1.045
75	1.161				0.629	0.686	0.854	1.101	1.318	1.005	1.119

\* = Sensible capacity equals total capacity  
 AHR/ISO/ASHRAE 13256-1 uses entering air conditions of Cooling - 80.6°F DB/66.2°F WB,  
 and Heating - 68°F DB/59°F WB entering air temperature

# Blower Performance Data – TSM09

External Static Pressure (in. wg)							
		Speed Tap	0.0	0.1	0.2	0.3	
PSC - Low Static	Low	RPM	760	870			
		Power (W)	59	54			
		CFM	290	270			
	Medium	RPM	890	940	1000		
		Power (W)	71	66	61		
		CFM	350	310	270		
	High	RPM	990	1060	1080	1100	
		Power (W)	85	80	75	69	
		CFM	400	370	310	240	
ECM - Constant Torque	1	RPM	680				
		Power (W)	20				
		CFM	250				
	2	RPM	760	870			
		Power (W)	27	30			
		CFM	290	270			
	3	RPM	930	1000	1100	1180	
		Power (W)	43	47	51	54	
		CFM	370	340	320	290	
	4	RPM	1010	1070	1160	1240	
		Power (W)	54	58	62	66	
		CFM	410	380	360	330	
	ECM - Constant Volume	250	CFM	0.0	0.1	0.2	0.3
			RPM	680	830	960	1120
		300	Power (W)	22	30	38	47
RPM			780	920	1060	1200	
350		Power (W)	29	38	48	58	
		RPM	890	1020	1160	1280	
400		Power (W)	40	50	62	73	
		RPM	990	1110	1240	1340	
		Power (W)	52	65	79	92	

All data is presented as lowest of nameplate voltage.

All data is shown wet coil with clean 1" filter.

All data is ran at 80°F DB and 67°F WB.

CFM Tolerance is 7%.

RPM/Watt Tolerance 10%.

■ Denotes Operation not recommended.

# Blower Performance Data – TSM12

External Static Pressure (in. wg)											
		Speed Tap	0.0	0.1	0.2	0.3					
PSC - Low Static	Low	RPM	760								
		Power (W)	61								
		CFM	300								
	Medium	RPM	830				930				
		Power (W)	74				69				
		CFM	340				320				
	High	RPM	1030				1090			1120	
		Power (W)	90				85			79	
		CFM	450				420			360	
ECM - Constant Torque	1	RPM	800								
		Power (W)	29								
		CFM	320								
	2	RPM	870				960	1050			
		Power (W)	40				44	48			
		CFM	360				340	310			
	3	RPM	960				1040	1130		1220	
		Power (W)	59				63	67		71	
		CFM	410				390	370		350	
	4	RPM	1030				1110	1190		1280	
		Power (W)	78				82	87		91	
		CFM	450				430	420		400	
	ECM - Constant Volume	300	CFM				0.0	0.1		0.2	0.3
			RPM				760	890		1040	1170
		350	Power (W)				29	38		48	58
RPM			850	980	1100	1220					
400		Power (W)	40	50	62	73					
		RPM	940	1060	1170	1280					
450		Power (W)	52	65	79	92					
		RPM	1030	1140	1230	1330					
500		Power (W)	73	87	101	115					
		RPM	1120	1220							
Power (W)		97	111								

All data is presented as lowest of nameplate voltage.  
 All data is shown wet coil with clean 1" filter.  
 All data is ran at 80°F DB and 67°F WB.  
 CFM Tolerance is 7%.  
 RPM/Watt Tolerance 10%.  
■ Denotes Operation not recommended.



# Blower Performance Data – TSM15

External Static Pressure (in. wg)							
		Speed Tap	0.0	0.1	0.2	0.3	
PSC - Low Static	Low	RPM	600				
		Power (W)	153				
		CFM	440				
	Medium	RPM	680	740	810	870	
		Power (W)	183	177	172	166	
		CFM	520	500	480	450	
	High	RPM	810	860	900	950	
		Power (W)	224	215	205	196	
		CFM	650	640	610	570	
ECM - Constant Torque	Speed Tap		0.0	0.1	0.2	0.3	
	1	RPM	590				
		Power (W)	41				
		CFM	430				
	2	RPM	660	710	760	810	
		Power (W)	49	59	59	59	
		CFM	500	460	410	370	
	3	RPM	760	800	840	890	
		Power (W)	77	77	77	86	
		CFM	600	570	520	480	
	4	RPM	780	830	870	910	
		Power (W)	92	92	103	103	
		CFM	620	600	560	520	
	5	RPM	870	900	940	990	
		Power (W)	120	120	130	130	
		CFM	710	690	660	630	
	ECM - Constant Volume	CFM		0.0	0.1	0.2	0.3
		450	RPM	610	700	790	870
Power (W)			39	53	67	82	
500		RPM	660	740	820	900	
		Power (W)	50	64	78	93	
600		RPM	760	830	890	970	
		Power (W)	83	97	111	125	
650		RPM	810	870	930	1000	
		Power (W)	104	118	133	147	
700		RPM	860	910	960	1030	
	Power (W)	125	140	155	170		

All data is presented as lowest of nameplate voltage.  
 All data is shown wet coil with clean 1" filter.  
 All data is ran at 80°F DB and 67°F WB.  
 CFM Tolerance is 7%.  
 RPM/Watt Tolerance 10%.  
■ Denotes Operation not recommended.

# Blower Performance Data – TSM18

External Static Pressure (in. wg)							
		Speed Tap	0.0	0.1	0.2	0.3	
PSC - Low Static	Low	RPM	■				
		Power (W)	■				
		CFM	■				
	Medium	RPM	600	660	730	810	
		Power (W)	182	176	170	165	
		CFM	520	500	470	440	
	High	RPM	750	790	840	900	
		Power (W)	221	212	203	194	
		CFM	660	630	600	570	
ECM - Constant Torque	Speed Tap		0.0	0.1	0.2	0.3	
	1	RPM	650	■			
		Power (W)	57	■			
		CFM	460	■			
	2	RPM	730	760	810	■	
		Power (W)	70	80	80	■	
		CFM	530	500	470	■	
	3	RPM	790	820	870	920	
		Power (W)	97	97	107	107	
		CFM	580	550	520	490	
	4	RPM	880	920	950	1000	
		Power (W)	137	137	147	147	
		CFM	650	630	600	580	
	5	RPM	950	990	1030	1070	
		Power (W)	177	177	187	187	
		CFM	710	690	670	650	
	ECM - Constant Volume	CFM		0.0	0.1	0.2	0.3
		450	RPM	530	640	740	820
Power (W)			29	43	56	69	
500		RPM	600	690	780	860	
		Power (W)	39	52	65	78	
600		RPM	660	740	820	900	
		Power (W)	51	65	79	93	
700		RPM	720	800	870	940	
		Power (W)	67	81	95	109	
800		RPM	790	850	■		
		Power (W)	86	100	■		

All data is presented as lowest of nameplate voltage.  
 All data is shown wet coil with clean 1" filter.  
 All data is ran at 80°F DB and 67°F WB.  
 CFM Tolerance is 7%.  
 RPM/Watt Tolerance 10%.  
 ■ Denotes Operation not recommended.

# Blower Performance Data – TSM24

External Static Pressure (in. wg)							
		Speed Tap	0.0	0.1	0.2	0.3	
<b>PSC - Low Static</b>	Low	RPM					
		Power (W)					
		CFM					
	Medium	RPM	640	690	750	820	
		Power (W)	236	227	217	208	
		CFM	690	670	640	590	
	High	RPM	710	760	820	880	
		Power (W)	297	285	272	260	
		CFM	860	840	810	770	
<b>ECM - Constant Torque</b>	1	RPM	640	690	730		
		Power (W)	62	68	76		
		CFM	710	660	600		
	2	RPM	690	730	780	850	
		Power (W)	89	97	102	109	
		CFM	820	770	720	670	
	3	RPM	740	780	830	890	
		Power (W)	120	129	134	143	
		CFM	930	880	830	790	
	4	RPM		830	880	920	
		Power (W)		169	173	185	
		CFM		990	950	910	
	5	RPM					
		Power (W)					
		CFM					
	<b>ECM - Constant Volume</b>	600	CFM	0.0	0.1	0.2	0.3
			RPM	600	660	730	830
		700	Power (W)	70	87	104	122
RPM			640	700	770	860	
800		Power (W)	96	115	134	153	
		RPM	680	750	820	890	
900		Power (W)	122	143	164	184	
		RPM	720	790	860	920	
950		Power (W)	155	176	197	218	
		RPM	740	810	880	930	
			Power (W)	193	214	234	255

All data is presented as lowest of nameplate voltage.  
 All data is shown wet coil with clean 1" filter.  
 All data is ran at 80°F DB and 67°F WB.  
 CFM Tolerance is 7%.  
 RPM/Watt Tolerance 10%.  
 Denotes Operation not recommended.

# Blower Performance Data – TSM30

External Static Pressure (in. wg)							
		Speed Tap	0.0	0.1	0.2	0.3	
PSC - Low Static	Low	RPM	860	850	890	930	
		Power (W)	344	328	311	295	
		CFM	1010	980	940	880	
	Medium	RPM	920	910	940	970	
		Power (W)	385	365	345	325	
		CFM	1100	1070	1020	960	
	High	RPM	■				1090
		Power (W)	■				422
		CFM	■				1240
ECM - Constant Torque	1	RPM	770	770	800	■	
		Power (W)	105	113	118		
		CFM	880	830	780		
	2	RPM	860	840	880	940	
		Power (W)	151	158	165	170	
		CFM	1000	960	920	900	
	3	RPM	950	920	960	1000	
		Power (W)	210	217	225	229	
		CFM	1140	1100	1070	1030	
	4	RPM	■		1000	1040	1060
		Power (W)	■		285	295	299
		CFM	■		1230	1200	1160
	5	RPM	■				
		Power (W)	■				
		CFM	■				
	ECM - Constant Volume	750	CFM	0.0	0.1	0.2	0.3
			RPM	690	720	790	880
		875	Power (W)	109	133	157	182
RPM			770	790	860	930	
1000		Power (W)	157	183	209	235	
		RPM	860	870	930	990	
1100		Power (W)	219	247	275	303	
		RPM	920	920	980	1030	
			Power (W)	310	336	361	387

All data is presented as lowest of nameplate voltage.  
 All data is shown wet coil with clean 1" filter.  
 All data is ran at 80°F DB and 67°F WB.  
 CFM Tolerance is 7%.  
 RPM/Watt Tolerance 10%.  
 ■ Denotes Operation not recommended.

# Blower Performance Data – TSM36

External Static Pressure (in. wg)							
		Speed Tap	0.0	0.1	0.2	0.3	
PSC - Low Static	Low	RPM	870	900			
		Power (W)	328	311			
		CFM	970	930			
	Medium	RPM	940	970	990	1020	
		Power (W)	363	344	324	305	
		CFM	1080	1040	980	910	
	High	RPM	1050	1090	1120	1150	
		Power (W)	468	441	415	389	
		CFM	1340	1280	1190	1090	
ECM - Constant Torque	1	RPM	880	910	950		
		Power (W)	131	132	141		
		CFM	990	950	910		
	2	RPM	970	1010	1050	1090	
		Power (W)	191	193	199	209	
		CFM	1130	1100	1080	1040	
	3	RPM	1070	1110	1150	1170	
		Power (W)	267	269	276	288	
		CFM	1280	1260	1240	1190	
	4	RPM	1190	1210	1250	1270	
		Power (W)	373	376	387	398	
		CFM	1450	1420	1410	1370	
	5	RPM					
		Power (W)					
		CFM					
	ECM - Constant Volume	900	CFM	0.0	0.1	0.2	0.3
			RPM	684	769	842	911
		1050	Power (W)	110	140	170	190
RPM			792	865	922	985	
1200		Power (W)	180	210	230	260	
		RPM	899	948	1014	1076	
1350		Power (W)	260	290	330	370	
		RPM	985	1071	1100	1152	
			Power (W)	350	420	440	480

All data is presented as lowest of nameplate voltage.  
 All data is shown wet coil with clean 1" filter.  
 All data is ran at 80°F DB and 67°F WB.  
 CFM Tolerance is 7%.  
 RPM/Watt Tolerance 10%.  
     Denotes Operation not recommended.

# ECM-CV Blower Performance Data

## TSM Non Ducted ECM-CV 88 and 80" Cabinet

All data wet coil clean filter

Tranquility Model	Setting	Cooling Mode		Heating Mode		Dehumid Mode		Continuous Fan Only Mode
		Fan Motor Stage 1	Fan Motor Stage 2*	Fan Motor Stage 1	Fan Motor Stage 2*	Fan Motor Stage 1	Fan Motor Stage 2*	
TSM09	Default	250	350	250	350	250	300	250
	Min	250	250	250	250	250	250	250
	Max	400	400	400	400	400	400	400
TSM12	Default	300	400	300	400	300	350	300
	Min	300	300	300	300	300	300	300
	Max	500	500	500	500	500	500	500
TSM15	Default	500	600	500	600	500	500	500
	Min	500	500	500	500	500	500	500
	Max	700	700	700	700	700	700	700
TSM18	Default	600	700	600	700	600	600	500
	Min	600	600	600	600	500	500	500
	Max	800	800	800	800	800	800	800
TSM24	Default	650	850	650	850	650	650	600
	Min	650	650	650	650	600	600	600
	Max	950	950	950	950	950	950	950
TSM30	Default	850	1000	900	1000	850	850	700
	Min	850	850	900	900	800	800	700
	Max	1100	1100	1100	1100	900	1100	1100
TSM36	Default	900	1200	900	1250	900	900	900
	Min	900	900	900	900	900	900	900
	Max	1250	1250	1350	1350	1250	1250	1250

All units AHRI/ISO/ASHRAE 13256-1 rated on CFM shown on performance data page.

If unit is dual voltage rated, then the airflow is rated at the lowest voltage, i.e. 208V for 208-230V units.

Shipped on default settings. C=Cooling; H=Heating; D=Dehumidification

Change from default setting with Service tool (ACDU03C) or Communicating thermostat (ATC32U03C).

Airflow is controlled within 7%, up to the max ESP.

TSL15-36 ramp default is 30 sec.

\* - Stage 2 ECM CV motor speed is engaged with a thermostat Y2 call. TSM Series is only available with single-stage compressors.

# Physical Data

Model	09	12	15	18	24	30	36
Compressor (1 Each)	Rotary				Scroll		
Factory Charge HFC-410A (oz) [kg]	35 [.99]	35 [.99]	43 [1.22]	53 [1.50]	71 [2.01]	66 [1.87]	75 [2.13]
<b>Motor &amp; Blower</b>							
208-230V PSC (HP) [W]	1/30 [25]	1/15 [50]	1/6 [124]	1/6 [124]	1/5 [149]	1/3 [249]	1/3 [249]
265V PSC (HP) [W]	1/30 [25]	1/15 [50]	1/6 [124]	1/6 [124]	1/5 [149]	1/2 [373]	1/2 [373]
ECM Constant Volume (HP) [W]	1/8 [93]	1/8 [93]	1/3 [249]	1/3 [249]	1/3 [249]	1/3 [249]	1/2 [373]
ECM Constant Torque (HP) [W]	1/4 [186]	1/4 [186]	1/3 [249]	1/3 [249]	1/2 [373]	1/2 [373]	3/4 [560]
Blower Wheel Size (diam x w) - (in) [mm]	6.75 x 7.25 [165 x 184]		9.5 x 7.12 [241 x 180]		10.63 x 8.0 [270 x 203]		
<b>Chassis Air Coil</b>							
Air Coil Dimensions (h x w) - (in) [mm]	28 x 12.625 [711 x 321]		28 x 14 [711 x 356]		30 x 18 [762 x 457]		
Return Air Filter Dimensions (h x w) - (in) [mm]	30 x 14 [762 x 356]		30 x 16 [762 x 406]		32 x 20 [813 x 508]		
Coax Volume (Gallons) [Liters]	0.26 [.98]		0.36 [1.4]		0.60 [2.3]		
Hose Size (in)	1/2		3/4		1		
<b>Weight</b>							
Chassis - (lbs) [kg]	110 [50]	117 [53]	123 [56]	125 [57]	186 [84]	190 [86]	192 [87]
80" Cabinet - (lbs) [kg]	114 [52]		133 [60]		170 [77]		
88" Cabinet - (lbs) [kg]	128 [58]		148 [67]		185 [84]		

Unit wiring diagrams available at [www.climatemaster.com](http://www.climatemaster.com). Select 'Commercial Professional', 'Literature', 'Wiring Diagrams'.

Unit Maximum Water Working Pressure	
Options	Max Pressure PSIG [kPa]
Base Unit (Hoses)	400 [2757]
Internal Secondary Pump (ISP)	200 [1.378]
Internal Motorized Water Valve (MWV)	300 [2,068]
Internal Modulating Valve	300 [2,068]
Internal Auto Flow Valve	400 [2,757]

Use the lowest maximum pressure rating when multiple options are combined.

\* Units with water valve have 300 [2068] High Pressure Water Switch – 250 [1723] Auto Reset

# Electrical Data – PSC Low Static Motor (208/230V) and (265V)

## PSC Low Static Motor (208/230V)

Model #	Voltage Code "G"	Compressor		Blower Motor	Pump Option	Total Unit FLA	Min Circuit Amps	Max Fuse Amps
		RLA	LRA	FLA	FLA			
TSM09	208/230-60-1	3.7	22	0.3	0.0	4.0	4.9	15
					0.6			
TSM12		4.6	30	0.7	0.0	5.3	6.5	15
					0.6			
TSM15		5.6	29	1.0	0.0	6.6	8.0	15
					0.6			
TSM18		6.6	33	1.0	0.0	7.6	9.3	15
					0.6			
TSM24		12.8	58.3	1.1	0.0	13.9	17.1	25
					0.6			
TSM30		12.8	64	2.7	0.0	15.5	18.7	30
					0.6			
TSM36	14.1	77	2.7	0.0	16.8	20.3	30	
				0.6				17.4

## PSC Low Static Motor (265V)

Model #	Voltage Code "E"	Compressor		Blower Motor	Pump Option	Total Unit FLA	Min Circuit Amps	Max Fuse Amps
		RLA	LRA	FLA	FLA			
TSM09	265-60-1	3.5	22	0.3	0.0	3.8	4.7	15
					0.6			
TSM12		3.9	23	0.6	0.0	4.5	5.4	15
					0.6			
TSM15		5.0	28	0.9	0.0	5.9	7.1	15
					0.6			
TSM18		5.6	28	0.9	0.0	6.5	7.9	15
					0.6			
TSM24		9.6	54	0.9	0.0	10.5	12.9	20
					0.6			
TSM30		10.9	60	2.0	0.0	12.9	15.6	25
					0.6			
TSM36	12.2	72	2.0	0.0	14.2	17.3	25	
				0.6				14.8

Unit wiring diagrams available at [www.climatemaster.com](http://www.climatemaster.com). Select 'Commercial Professional', 'Literature', 'Wiring Diagrams'.



## Electrical Data – ECM-CV Motor (208/230V) and (265V)

### ECM-CV Motor (208/230V)

Model #	Voltage Code "G"	Compressor		Blower Motor	Pump Option	Total Unit FLA	Min Circuit Amps	Max Fuse Amps
		RLA	LRA	FLA	FLA			
TSM09	208/230-60-1	3.7	22	1.5	0.0	5.2	6.1	15
					0.6			
TSM12		4.6	30	1.5	0.0	6.1	7.3	15
					0.6			
TSM15		5.6	29	2.6	0.0	8.2	9.6	15
					0.6			
TSM18		6.6	33	2.6	0.0	9.2	10.9	15
					0.6			
TSM24		12.8	58.3	2.6	0.0	15.4	18.6	30
					0.6			
TSM30		12.8	64	3.9	0.0	16.7	19.9	30
					0.6			
TSM36		14.1	77	3.9	0.0	18.0	21.5	35
					0.6			

### ECM-CV Motor (265V)

Model #	Voltage Code "E"	Compressor		Blower Motor	Pump Option	Total Unit FLA	Min Circuit Amps	Max Fuse Amps
		RLA	LRA	FLA	FLA			
TSM09	265-60-1	3.5	22	1.4	0.0	4.9	5.8	15
					0.6			
TSM12		3.9	23	1.4	0.0	5.3	6.2	15
					0.6			
TSM15		5.0	28	2.1	0.0	7.1	8.4	15
					0.6			
TSM18		5.6	28	2.1	0.0	7.7	9.1	15
					0.6			
TSM24		9.6	54	2.1	0.0	11.7	14.1	20
					0.6			
TSM30		10.9	60	3.2	0.0	14.1	16.8	25
					0.6			
TSM36		12.2	72	3.2	0.0	15.4	18.5	30
					0.6			

Unit wiring diagrams available at [www.climate-master.com](http://www.climate-master.com). Select 'Commercial Professional', 'Literature', 'Wiring Diagrams'.

## Electrical Data – ECM-CT Motor (208/230V) and (265V)

### ECM-CT Motor (208/230V)

Model #	Voltage Code "G"	Compressor		Blower Motor	Pump Option	Total Unit FLA	Min Circuit Amps	Max Fuse Amps
		RLA	LRA	FLA	FLA			
TSM09	208/230-60-1	3.7	22	2.3	0.0	6.0	6.9	15
					0.6			
TSM12		4.6	30	2.3	0.0	6.9	8.1	15
					0.6			
TSM15		5.6	29	2.5	0.0	8.1	9.5	15
					0.6			
TSM18		6.6	33	2.5	0.0	9.1	10.8	15
					0.6			
TSM24		12.8	58.3	4.3	0.0	17.1	20.3	30
					0.6			
TSM30		12.8	64	4.3	0.0	17.1	20.3	30
					0.6			
TSM36	14.1	77	6.1	0.0	20.2	23.7	35	
				0.6				20.8

### ECM-CT Motor (265V)

Model #	Voltage Code "E"	Compressor		Blower Motor	Pump Option	Total Unit FLA	Min Circuit Amps	Max Fuse Amps
		RLA	LRA	FLA	FLA			
TSM09	265-60-1	3.5	22	2.3	0.0	5.8	6.7	15
					0.6			
TSM12		3.9	23	2.3	0.0	6.2	7.1	15
					0.6			
TSM15		5.0	28	2.5	0.0	7.5	8.8	15
					0.6			
TSM18		5.6	28	2.5	0.0	8.1	9.5	15
					0.6			
TSM24		9.6	54	4.3	0.0	13.9	16.3	25
					0.6			
TSM30		10.9	60	4.3	0.0	15.2	17.9	25
					0.6			
TSM36	12.2	72	6.1	0.0	18.3	21.4	30	
				0.6				18.9

Unit wiring diagrams available at [www.climatemaster.com](http://www.climatemaster.com). Select 'Commercial Professional', 'Literature', 'Wiring Diagrams'.

# Typical Unit – Exploded View

## Major Components

### 1. TSM Cabinet (Furred-in)

- A - floating condensate drain pan
- B - drain P trap
- C - supply air plenum
- D - optional surface mount thermostat 2 x 4 box horizontal
- E - optional disconnect / breaker location
- F - upper control box (high voltage terminal blocks optional MPC)
- G - blower assembly/motor
- H - risers (not shown)
- I - shutoffs (not shown)
- J - filter panel
- K - filter

### 2. TSM Chassis

- A - compressor with acoustic enclosure, water coil, reversing valve
- B - data plate
- C - lower control box (transformer, CXM/DXM2, contactor)
- D - capacitor

- E - high and low voltage locking quick connectors
- F - air coil
- G - Optional Service Connection (DXM2 Controls only)

### 3. Architectural Acoustic Return Air Panel (G)

- A - frame
- B - hinged inner panel

### 4. Hoses (Not Shown)

### 5. Supply Air Grille (Not Shown)

### 6. Thermostat (Not Shown)

**Note** - Matching labels for visual aid, chassis and cabinet same size and voltage



# TSM – Standard Unit, Furred in Cabinet with Risers

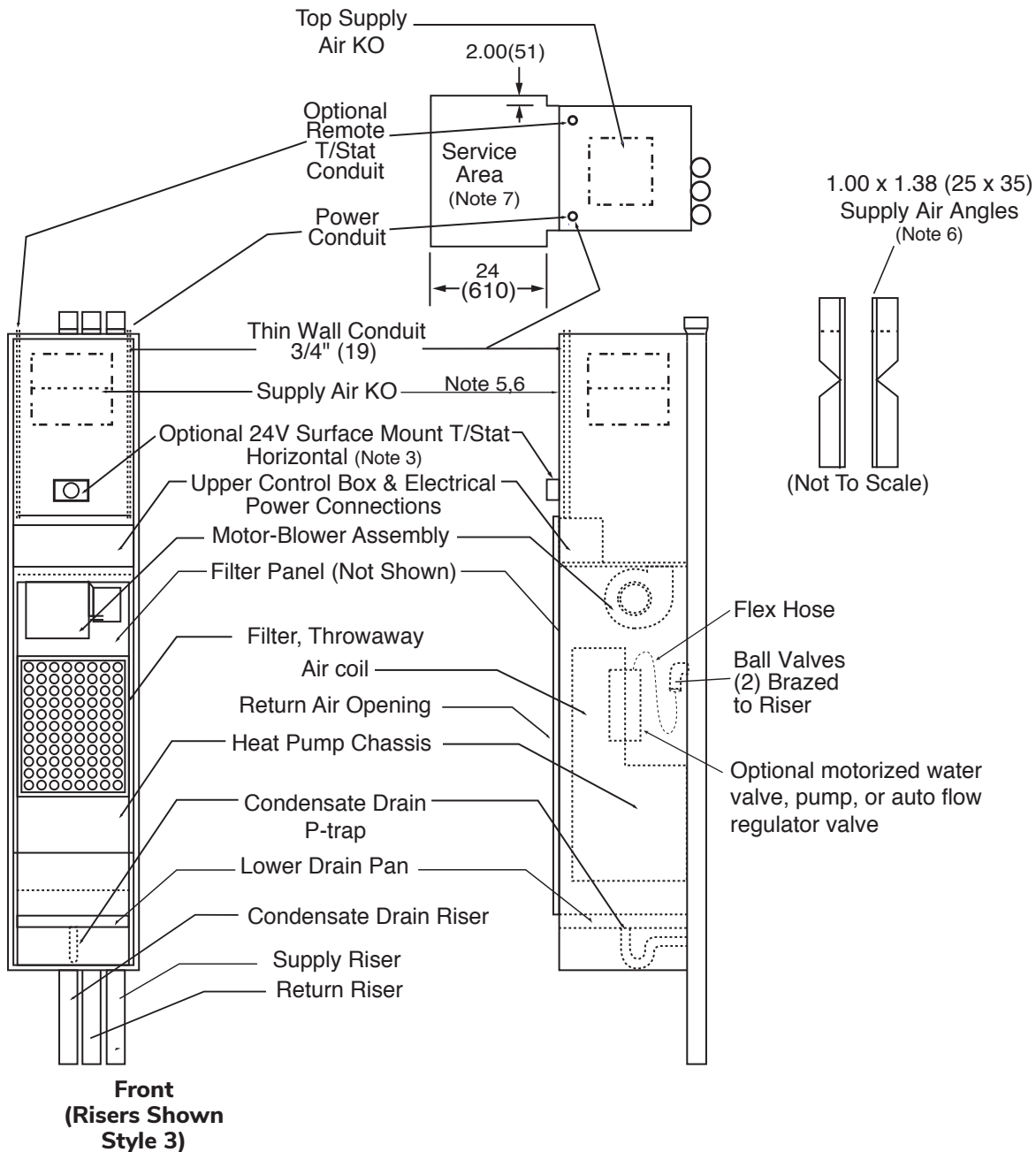

## Notes:

1. All dimensions are in inches (mm).
2. The return air/control box side is defined as front of cabinet. Supply air K.O.'s and riser K.O.'s are on all panels. Supply air grilles can be on any side except riser side.
3. Units with 24v surface mount T/stat option have 2x4 box factory installed in horizontal position. Contractor must turn box before dry walling if customer is using vertical thermostat type.
4. Cabinet shown is Style 3, risers back right.
5. Supply air K.O.'s can be configured in field or in factory.
6. If supply air is field configured the angles are shipped loose. Quality of angles depends on your selection of cabinet digits 11 and 12. Break off if needed. Position inside and attach with screws.
7. Service area from finished wall, and 4"(102) wider than cabinet.

# TSM – Leader Unit, Furred in Cabinet

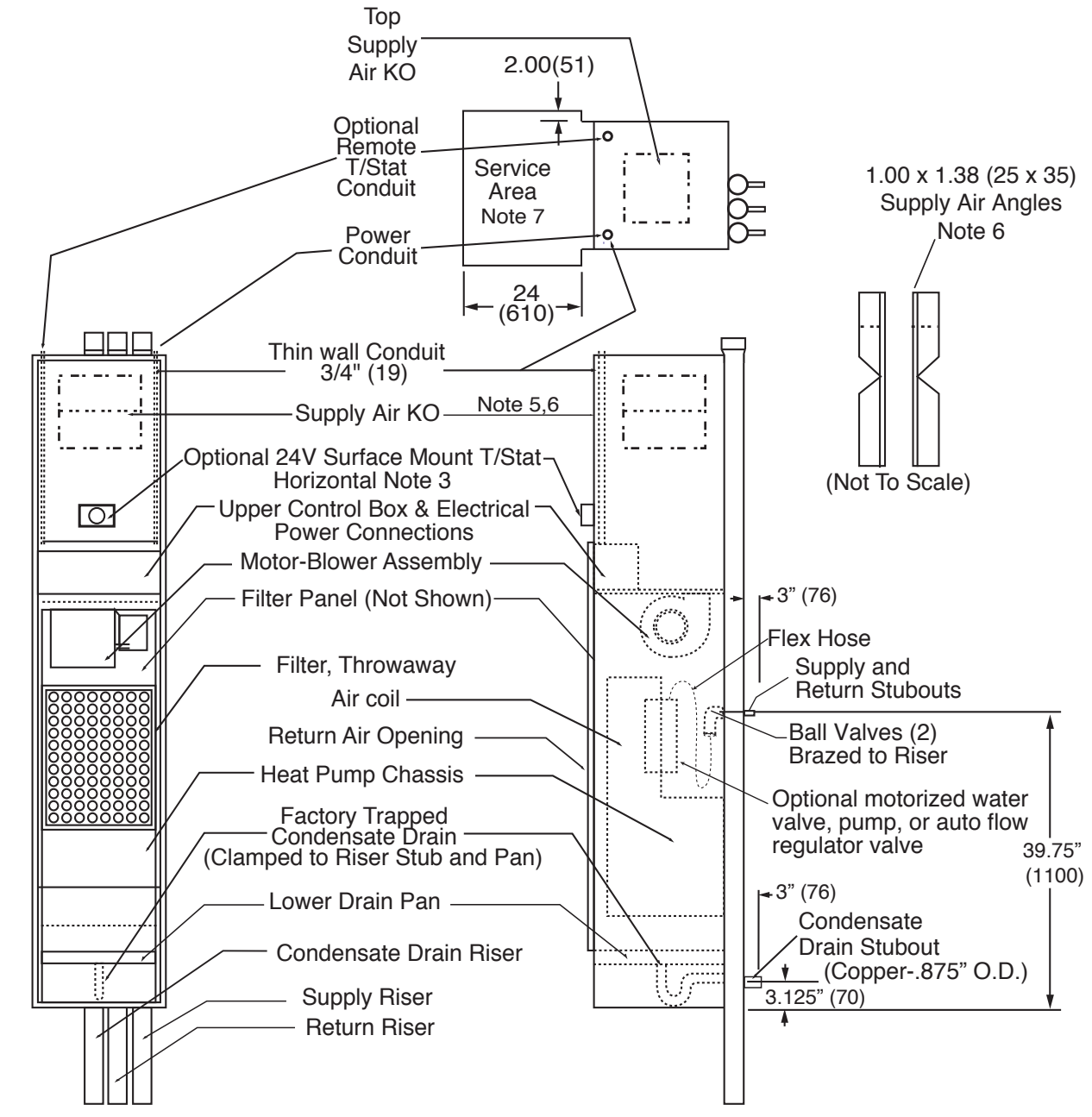

## Notes:

1. All dimensions are in inches (mm).
2. The return air/control box side is defined as front of cabinet. Supply air K.O.'s and riser K.O.'s are on all panels. Supply air grilles can be on any side except riser side.
3. Units with 24v surface mount T/stat option have 2x4 box factory installed in horizontal position. Contractor must turn box before dry walling if customer is using vertical thermostat type.
4. Cabinet shown is Style 3, risers back right.
5. Supply air K.O.'s can be configured in field or in factory.
6. If supply air is field configured the angles are shipped loose. Quality of angles depends on your selection of cabinet digits 11 and 12. Break off if needed. Position inside and attach with screws.
7. Service area from finished wall, and 4"(102) wider than cabinet.
8. Installer must provide crossover water piping from riser to follower unit. Piping must have same pressure rating or higher as riser.

# TSM – Follower Unit, Furred in Cabinet, No Risers

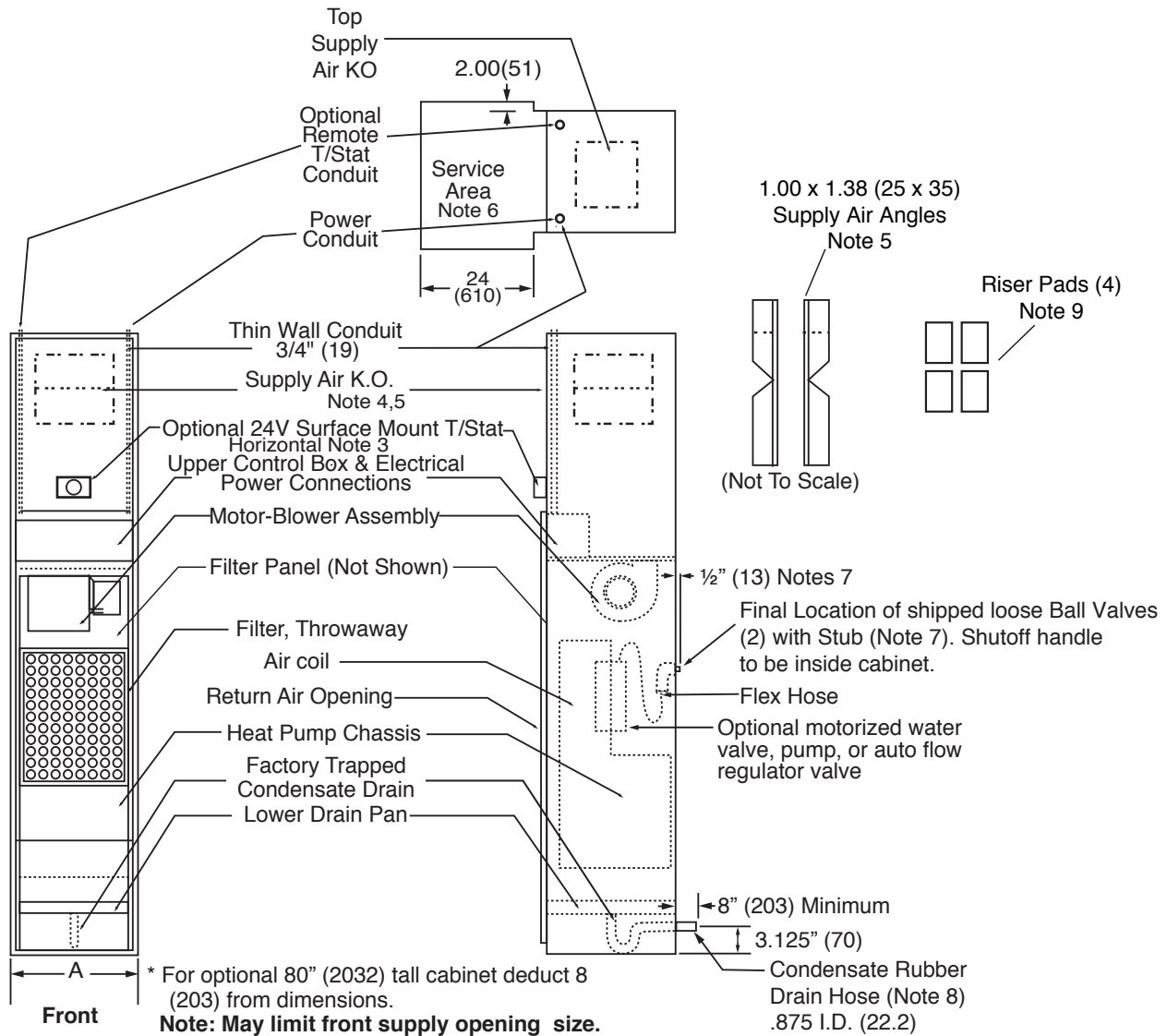

## Notes:

1. All dimensions are in inches (mm).
2. The return air/control box side is defined as front of cabinet. Supply air K.O.'s and riser K.O.'s are on all panels. Supply air grilles can be on any side except riser side.
3. Units with 24v surface mount T/stat option have 2x4 box factory installed in horizontal position. Contractor must turn box before dry walling if customer is using vertical thermostat type.
4. Supply air K.O.'s can be configured in field or in factory.
5. If supply air is field configured the angles are shipped loose. Quality of angles depends on your selection of cabinet digits 11 and 12. Break off if needed. Position inside and attach with screws.
6. Service area from finished wall, and 4"(102) wider than cabinet.
7. Ball valve package is shipped loose in cabinet or shipped in bulk as special. Field must position in cabinet copper protruding 1/2" out of cabinet and connect to leader riser stub outs, extend copper if needed.
8. Rubber drain hose ships connected to the lower (cabinet) drain pan and must be cut to length and connected to the drain riser in the field. Recommend running hard tubing inside and clamping inside so there is future access.
9. Installer must apply riser pads to outside of cabinet to seal supply and return slots.

# Leader/Follower Cabinet

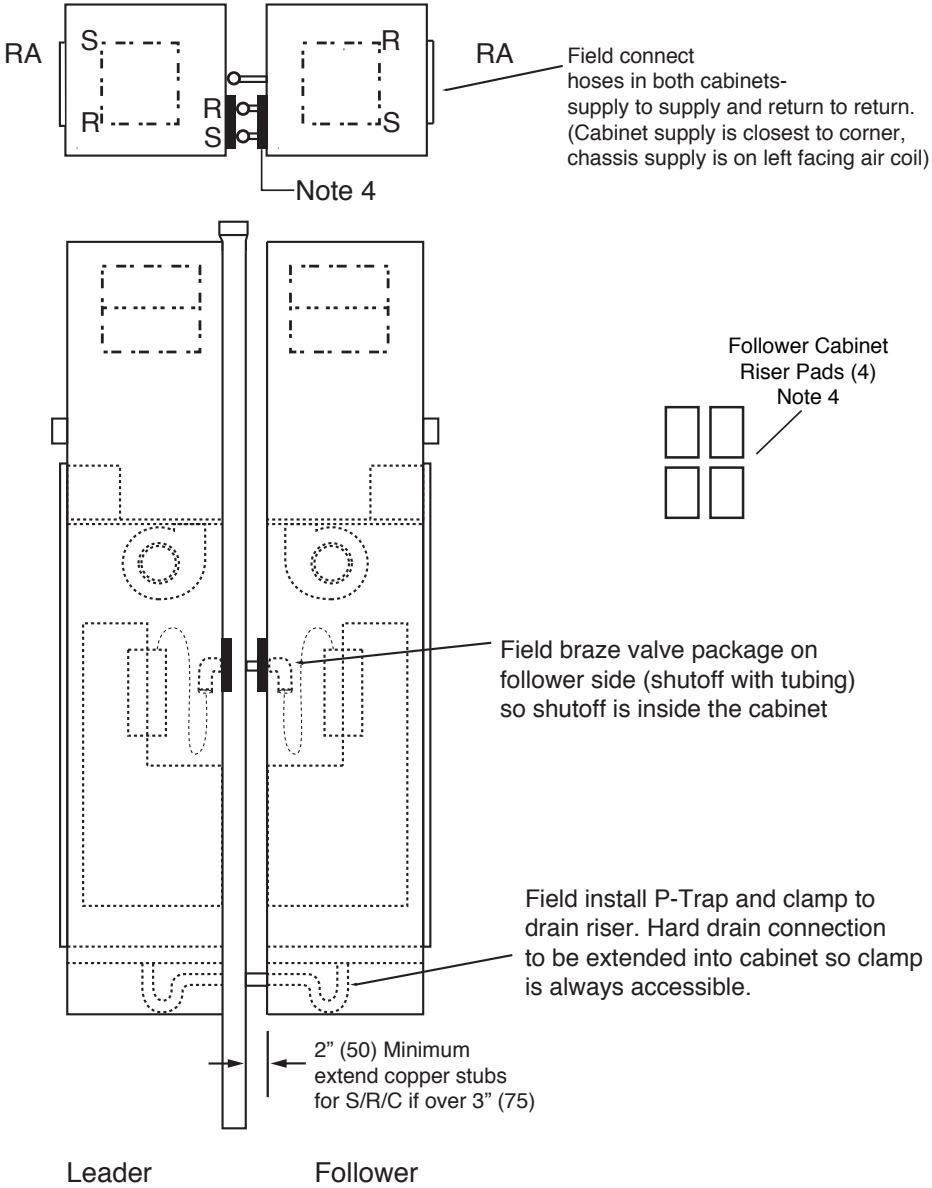

**Notes:**

1. Contractor must meet all building and fire code requirements.
2. Size riser diameter for both units GPM.
3. Leader/Follower means both units share common riser.
4. Install pads on back of follower cabinet to cover slots used for S/R risers.

**When cabinets are pushed up to risers allow sufficient clearance. Shutoffs should be inside cabinet.**

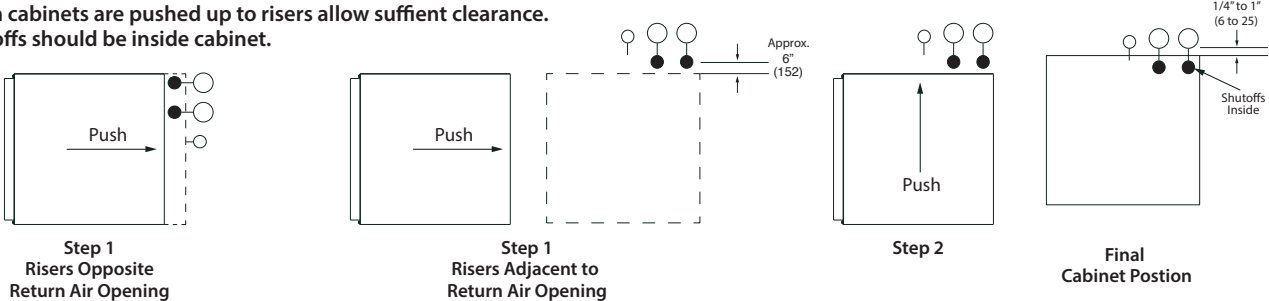

ClimateMaster works continually to improve its products. As a result, the design and specifications of each product at the time of order may be changed without notice and may not be as described herein. Please contact ClimateMaster's Customer Service Department at 1-405-745-6000 for specific information on the current design and specifications. Statements and other information contained herein are not express warranties and do not form the basis of any bargain between the parties, but are merely ClimateMaster's opinion or commendation of its products. The latest version of this document is available at [climatemaster.com](http://climatemaster.com). © ClimateMaster, Inc. All rights reserved 2013

# Cabinet Dimensions

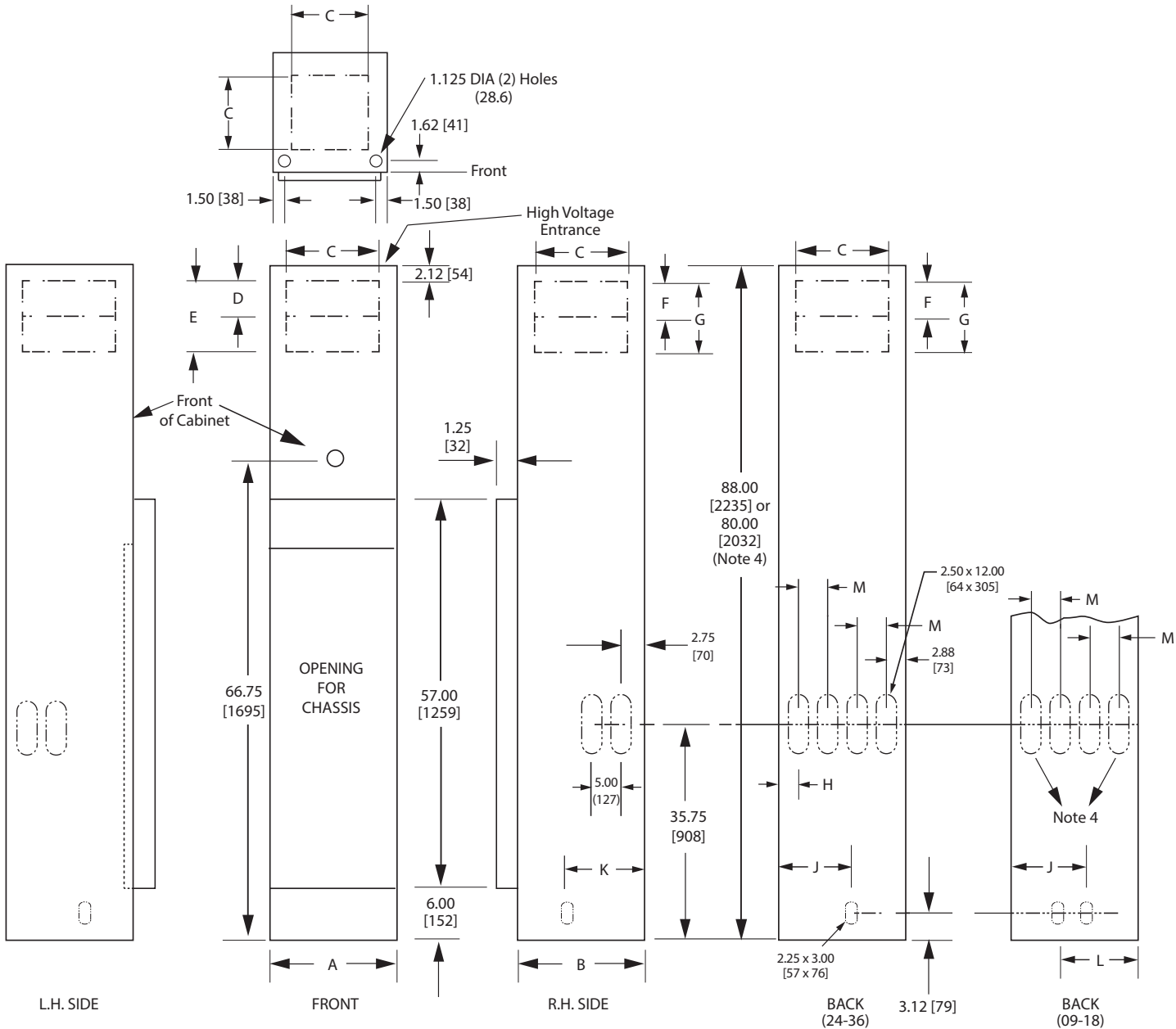

**Notes:**

1. All dimensions are in inches (mm).
2. Cabinets have supply air and riser K.O.'s, all panels. Remove only K.O.'s necessary to configure cabinet. Seal any K.O.'s removed by mistake.
3. Service area to be width of cabinet plus 4" [102] and 24" [610] from finished wall.
4. For 9-18 cabinet use drain diagonally across from supply and return risers.

Size	A	B	C	88" Cabinet		80" Cabinet		H	J	K	L	M
				D/F	E/G	D/F	G					
09-12	17.00 [432]	17.00 [432]	12.00 [305]	6.00 [152]	12.00 [305]	6.00 [152]	12.00 [305]	1.71 [44]	11.34 [288]	11.93 [303]	11.34 [288]	4.63 [117]
15-18	19.25 [489]	19.00 [483]	14.00 [356]	7.00 [178]	14.00 [356]	6.00 [152]	12.00 [305]	2.83 [72]	12.08 [307]	11.93 [303]	12.08 [307]	4.63 [117]
24-36	24.25 [616]	24.00 [610]	16.00 [406]	8.00 [203]	16.00 [406]	6.00 [152]	12.00 [305]	2.83 [72]	12.08 [307]	11.98 [304]	N/A	5.00 [127]

ClimateMaster works continually to improve its products. As a result, the design and specifications of each product at the time of order may be changed without notice and may not be as described herein. Please contact ClimateMaster's Customer Service Department at 1-405-745-6000 for specific information on the current design and specifications. Statements and other information contained herein are not express warranties and do not form the basis of any bargain between the parties, but are merely ClimateMaster's opinion or commendation of its products. The latest version of this document is available at [climatemaster.com](http://climatemaster.com). © ClimateMaster, Inc. All rights reserved 2013



# Cabinet Slot Dimensions and Riser Arrangements

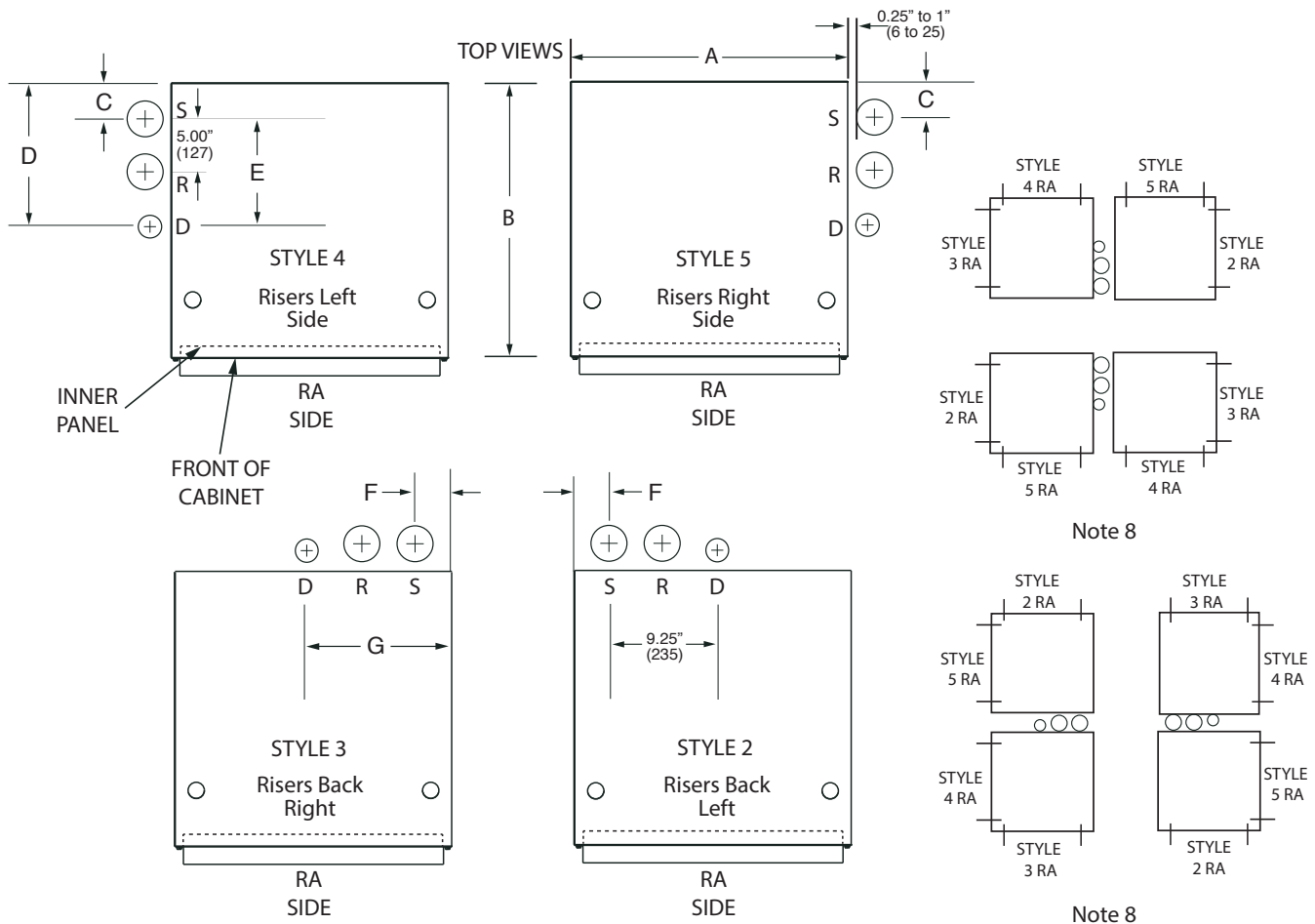

**NOTICE!** Not all styles will stack above or adjacent to each other. (See Note 8).

**Notes:**

1. Dimensions are inches [mm].
2. Style refers to cabinet model digit 9 - riser location.
3. Return air side is the front of the cabinet.
4. Supply riser is closest to corner.
5. Drain is not centered on D1-D4 (09-18) cabinets.
6. Slots allow for riser stack expansion and contraction.
7. Supply and return riser stub outs are 39.75" (1100) from bottom of cabinet and is not centered vertically in slot. Drain Run-out is 3.12" (79) from bottom of cabinet.
8. From floor to floor on one riser stack you can only have; all same style, styles 2 and 5; or styles 3 and 4. For leader/follower units you can only have styles 3 or 4 adjacent to 2 or 5.
9. Secure riser stack to building structure.
10. Riser should not touch cabinet and shutoff should be inside cabinet.

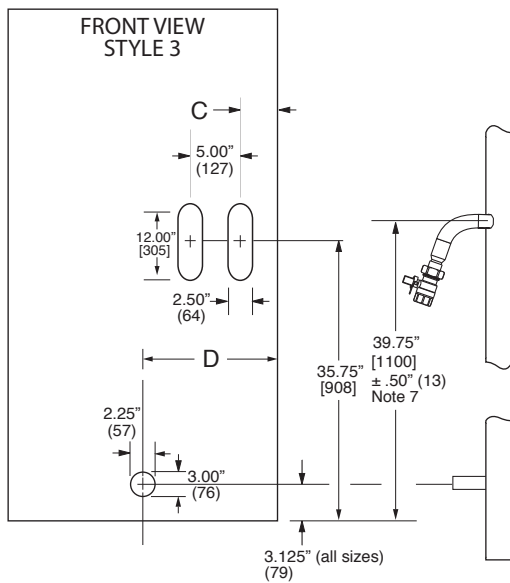

Size	A	B	C	D	E	F	G
09-12	17.00 [432]	17.00 [432]	2.75 [70]	11.93 [303]	9.18 [233]	1.71 [44]	11.34 [288]
15-18	19.25 [489]	19.00 [483]	2.75 [70]	11.93 [303]	9.18 [233]	2.83 [72]	12.08 [307]
24-36	24.25 [616]	24.00 [610]	2.73 [69]	11.98 [304]	9.25 [235]	2.83 [72]	12.08 [307]

ClimateMaster works continually to improve its products. As a result, the design and specifications of each product at the time of order may be changed without notice and may not be as described herein. Please contact ClimateMaster's Customer Service Department at 1-405-745-6000 for specific information on the current design and specifications. Statements and other information contained herein are not express warranties and do not form the basis of any bargain between the parties, but are merely ClimateMaster's opinion or commendation of its products. The latest version of this document is available at [climatemaster.com](http://climatemaster.com). © ClimateMaster, Inc. All rights reserved 2013

# TSM Cabinet Configurations

## Cabinet Model Digits 11 and 12 Describe Air Flow Configurations

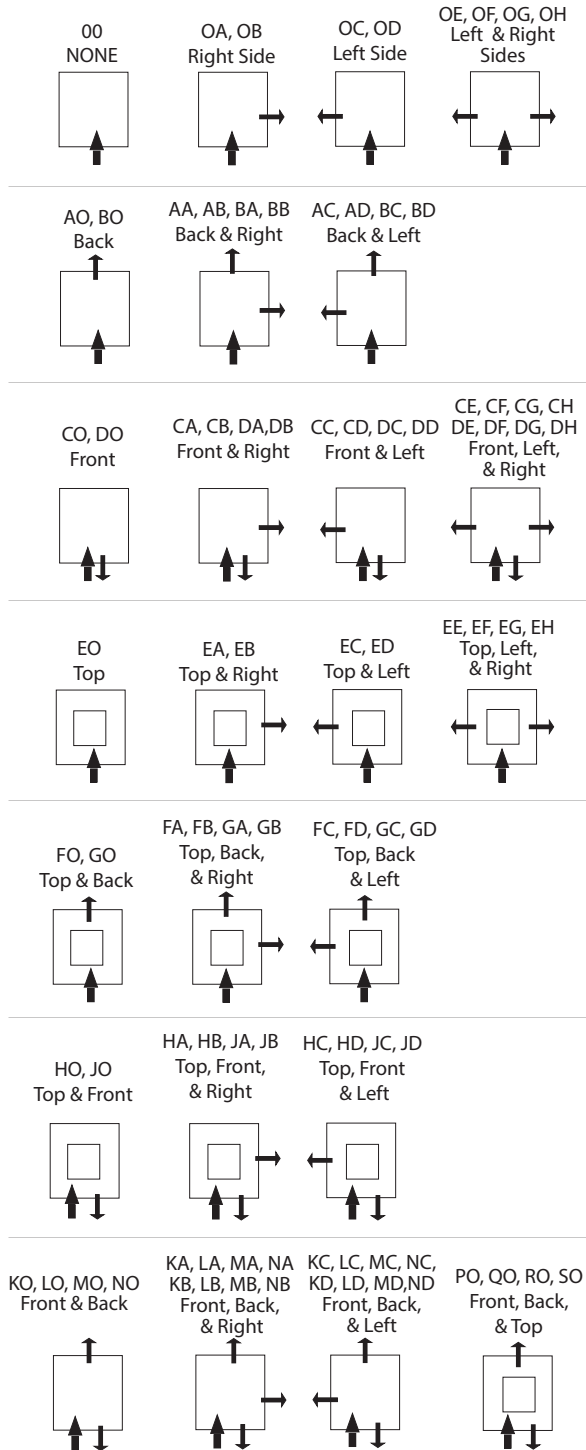

### Notes:

1. Front is return air side and control box location.
2. Risers can be on any side without return or supply air openings.
3. All sides and top have KO's.
4. 80" Cabinet cannot have front large discharge.

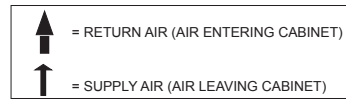

BACK/FRONT/TOP DISCHARGE OPTIONS – DIGIT 11						
OPTION	DISCHARGE	UNIT SIZE 09-12 TOP	UNIT SIZE 15-18 TOP	UNIT SIZE 24-36 TOP	C-SERIES 80" TSM	C-SERIES 88" TSM
0	NONE	N/A			YES	YES
A	BACK SMALL					
B	BACK LARGE					
C	FRONT SMALL					
D	FRONT LARGE	N/A			NO	
E	TOP					
F	BACK SMALL & TOP					
G	BACK LARGE & TOP					
H	FRONT SMALL & TOP	12 x 12	14 x 14	16 x 16	YES	
J	FRONT LARGE & TOP	N/A			NO	
K	BACK SMALL & FRONT SMALL					
L	BACK LARGE & FRONT LARGE					
M	BACK SMALL & FRONT LARGE					
N	BACK LARGE & FRONT SMALL	N/A			NO	
P	BACK SMALL & FRONT SMALL W/TOP					
Q	BACK LARGE & FRONT LARGE W/TOP					
R	BACK SMALL & FRONT LARGE W/TOP					
S	BACK LARGE & FRONT SMALL W/TOP	12 x 12	14 x 14	16 x 16	YES	
					NO	
					NO	
					YES	

SIDE DISCHARGE OPTIONS – DIGIT 12	
OPTION	DISCHARGE
0	NONE
A	RIGHT SMALL
B	RIGHT LARGE
C	LEFT SMALL
D	LEFT LARGE
E	RIGHT SMALL & LEFT SMALL
F	RIGHT LARGE & LEFT LARGE
G	RIGHT SMALL & LEFT LARGE
H	RIGHT LARGE & LEFT SMALL

DISCHARGE K.O. BY UNIT SIZE 88"		
T SIZE	Top	Back, Front & Side
09 thru 12	12" x 12"	12" x 6" & 12" x 12"
15 thru 18	14" x 14"	14" x 6" & 14" x 14"
24 thru 36	16" x 16"	16" x 8" & 16" x 16"

DISCHARGE K.O. BY UNIT SIZE 80"			
UNIT SIZE	Top	Front	Back & Side
09 thru 12	12" x 12"	12" x 6"	12" x 6" & 12" x 12"
15 thru 18	14" x 14"	14" x 6"	14" x 6" & 14" x 12"
24 thru 36	16" x 16"	16" x 6"	16" x 6" & 16" x 12"

# Typical Cabinet with "G" Panel Installation

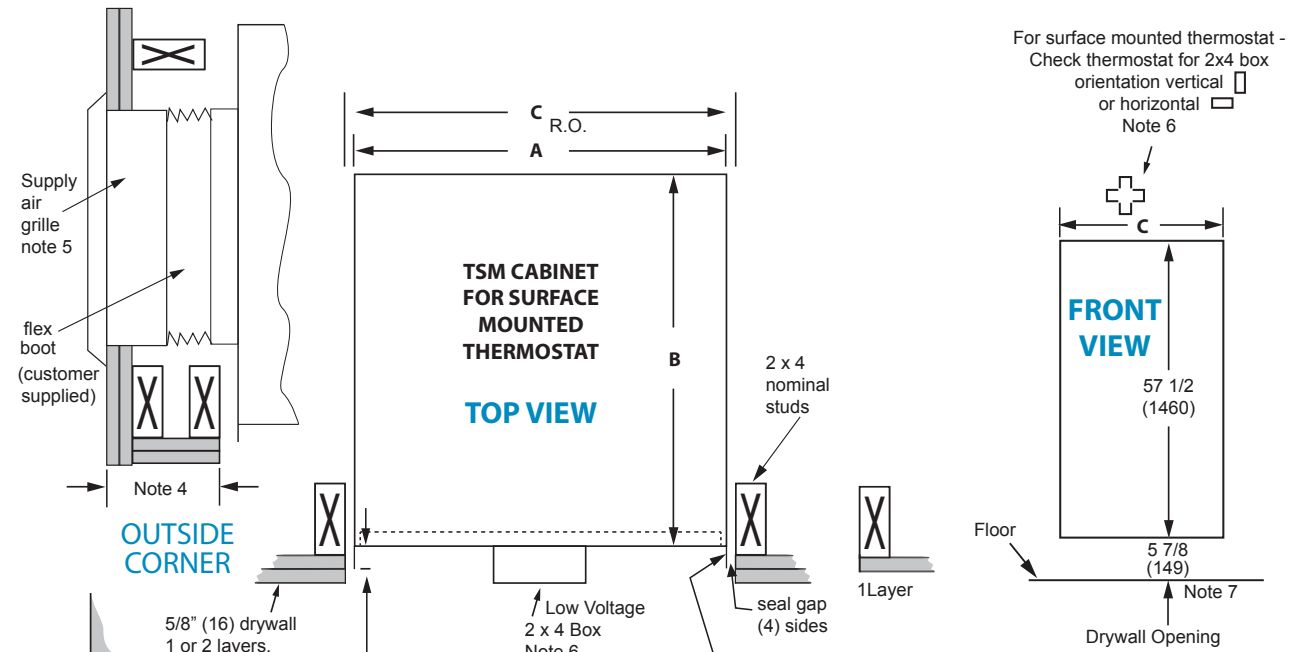

Model	A	B	C
09-12	17.00 [432]	17 [432]	17.25 [438]
15-18	19.25 [489]	19 [483]	19.50 [495]
24-36	24.25 [616]	24 [610]	24.50 [622]

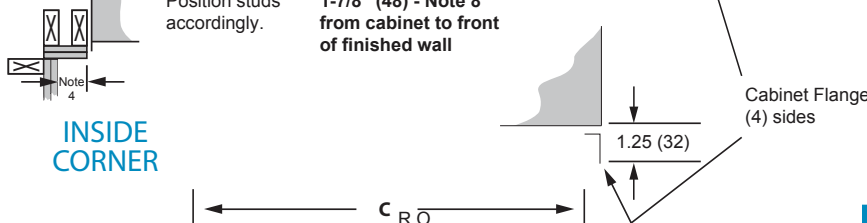

**NOTICE!**

Seal between studs and cabinet flanges with weather tight foam material to prevent wall cavity air from infiltrating unit or room.

## Notes:

1. All dimensions are in inches (mm).
2. Cabinet configuration will determine slab core drilling location and walls surrounding cabinet.
3. Recommend stud walls surrounding cabinet. Drywall and studs should not be attached or contacting cabinet for best sound attenuation. Where possible fill gaps with sound absorbing material. Use iso pad under cabinet. Secure cabinet to floor in two places at back.
4. Return air panel "G" (not shown) overlaps rough opening, allow minimum of 3 1/2" (89) dry wall to corner. Do not caulk panel to wall.
5. If supply air grille does not penetrate cabinet connect with flex boot. Customer supplied top duct should also connect with flex boot.
6. Before installing dry wall, contractor must turn box if needed. Horizontal is standard.
7. If cabinet stand or ISO pad is used add to dimension.
8. For 2" filter set cabinet 2" minimum from front of drywall.

# Typical Recessed Cabinet with "G" Panel and Frame Installation

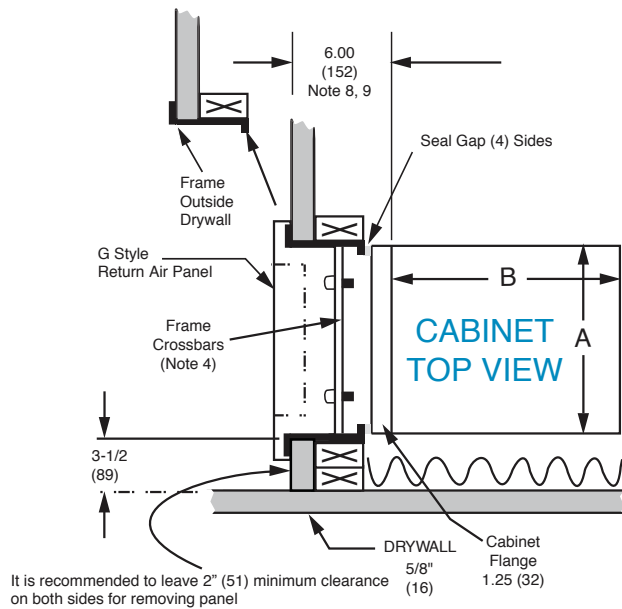

**▲ NOTICE! ▲**

Recessed cabinet requires a frame kit.

Outside air applications require a Motorized Damper or pre-treated air that is above 45°F degrees (7°C) and below 95°F degrees dry bulb/75°F degrees wet bulb.

Attach the frame to the wall studs, not the cabinet. Use weather seal material between the frame and cabinet to avoid bypass air being pulled in from the wall cavity.

Do not distort frame. Shim the sides, if required.

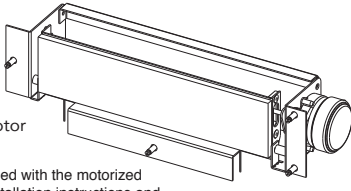

Optional Damper Motor  
(Order separately)  
Refer to the IOM packaged with the motorized damper assembly for installation instructions and note 7 (below) for its usage.

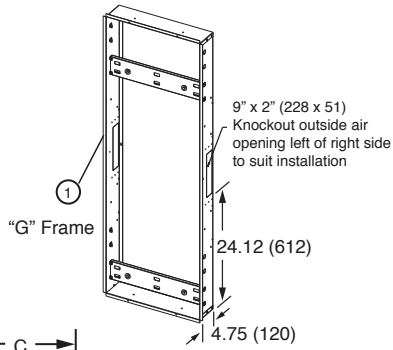

Kit Part	Qty	Description
1	1	Frame
2	2	Cross Bar

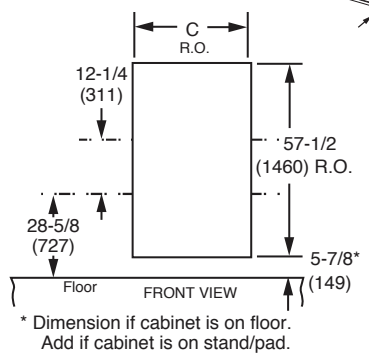

Kit	Size	Frame Kit			Panel
		A	B	C	D
48A0100N50	09-12	17.00 (432)	17.00 (432)	16-5/8 (400)	18.50 (470)
48A0100N51	15-18	19.25 (489)	19 (483)	19-5/8 (498)	21.50 (546)
48A0100N52	24-36	24.25 (616)	24 (610)	24-3/8 (620)	25.50 (648)

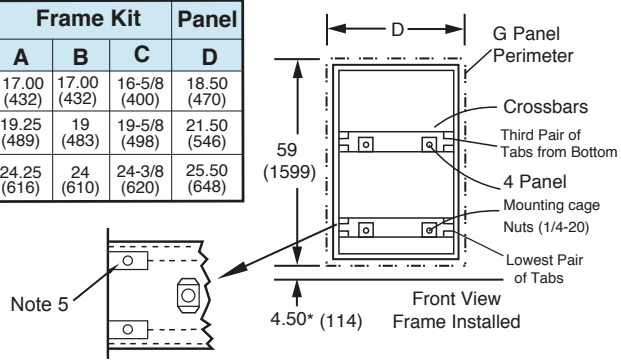

**Notes:**

- The cabinet configuration will determine the slab core drilling location and the wall surrounding the cabinet.
- Stud walls surrounding the cabinet are recommended. For better sound attenuation, the drywall studs should not be attached to or contacting the cabinet.
- The "G" style return air panel overlaps its rough opening. Allow a minimum of 3.5" (89) of drywall to a corner. Do not caulk the return air panel to the wall.
- The "G" panel attaches to the cross bars of the frame kit. The cabinet must be recessed behind the wall.
- For air filter access, pivot the hinged inner panel and open the snapped filter access panel.
- For chassis access,
  - Remove the entire G-Panel
  - Remove the (2x) cross bars of the frame kit
  - Remove the cabinet's filter panel
  - Slide out the chassis
- When untreated outside air will be utilized, the 48A0100N04 motorized damper must be used. The mixed air temperature must be no lower than 45°F degrees (7°C), must be no higher than 95°F DB/75°F WB, and must not exceed 20% of the cabinets total CFM output.
- For a 2" filter, set the cabinet 6.25" (158) from the front of the dry wall.
- If the drywall flanges (Qty. 4) are removed, the cabinet can be set 1" (25) closer to the finished drywall.
- All dimensions are inches (mm) with all nominal 2" x 4" studs being 1.5" (38) x 3.5" (89).

ClimateMaster works continually to improve its products. As a result, the design and specifications of each product at the time of order may be changed without notice and may not be as described herein. Please contact ClimateMaster's Customer Service Department at 1-405-745-6000 for specific information on the current design and specifications. Statements and other information contained herein do not express warranties and do not form the basis of any bargain between the parties, but are merely ClimateMaster's opinion or commendation of its products. The latest version of this document is available at [climatemaster.com](http://climatemaster.com). © ClimateMaster, Inc. All rights reserved 2013

# Hinged "G" Style Return Air Panel – AVHSG Series

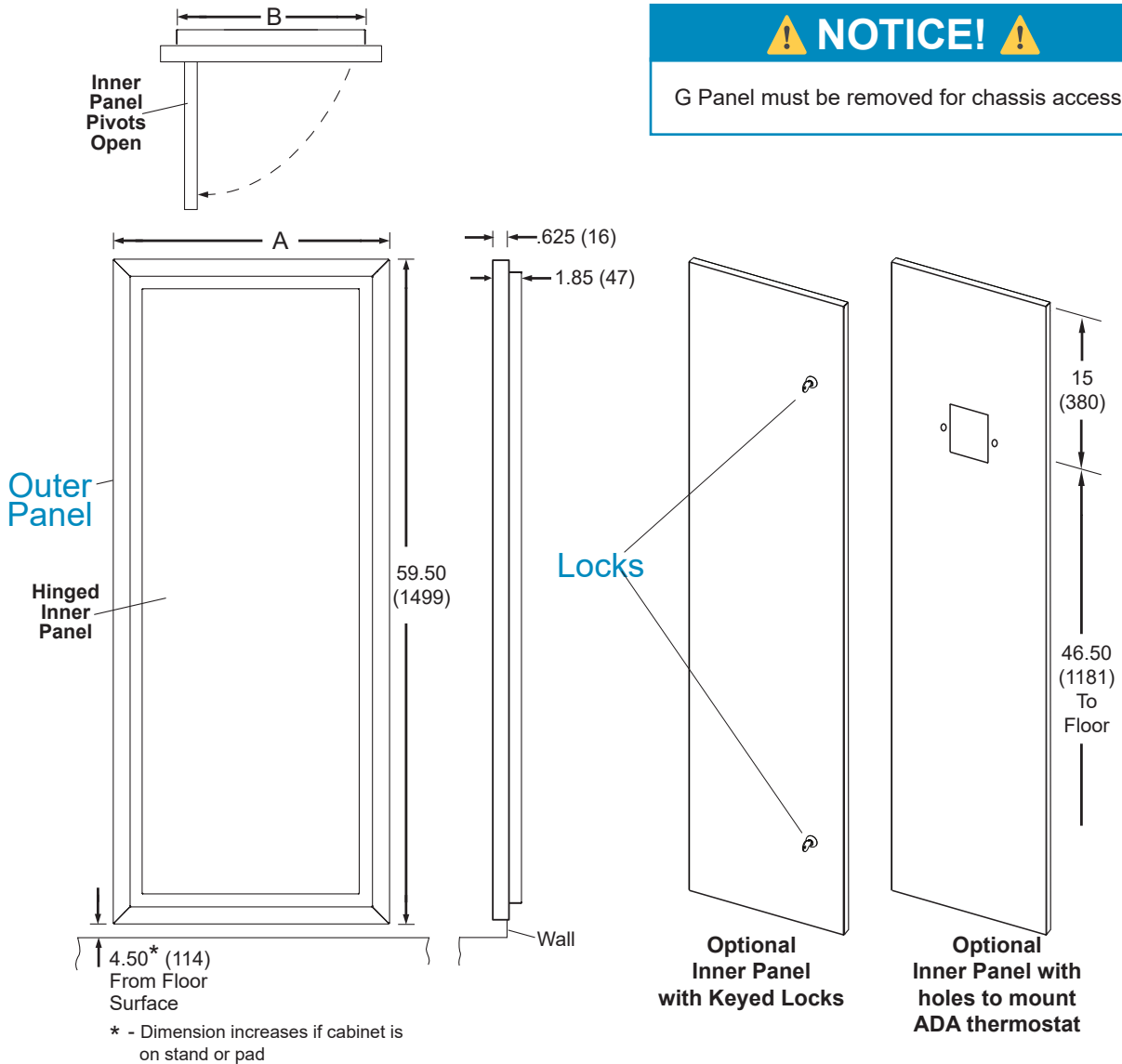

## Front View

Unit	AVHSG Digit 6	A	B
09- 12	1	19.30 [490]	16.40 [417]
15- 18	2	21.60 [549]	18.70 [475]
24 - 36	3	26.50 [673]	23.70 [602]

THERMOSTAT MOUNTING	
TYPE 1	TYPE 2
ATP21W02	AVB32V02C
ATA11U03	ATA32V01
ATC32U03C	
ATA11U01	
ABV32V03C	

### Notes:

- Dimensions are in inches (mm).
- Panel color Polar Ice, or Bright White
- Inner panel pivots open 90°, for filter replacement without removing panel.
- Shipped as left-hand pivot, but can be field converted to right hand. Cannot convert panel with grille, or ADA options.
- Optional locks, ADA, and louvered panel available.
- Optional frame for recessed cabinet applications and damper assembly available. See recessed cabinet.
- Please review the ADA Knock Out Type 1/Type 2 Thermostat Mounting table to ensure compatibility between the panel and thermostat selected.

# "L" Style (Flush Mounted) Return Air Panel – AVHRL Series

Unit	AVHRL Digit 6	D	E	F	G
09, 12	1	22.1	2.0	19.5	55.8
15, 18	2	24.1	2.0	21.5	55.8
24	3	29.6	2.0	26.5	55.9
30, 36	4	29.6	2.0	26.5	55.9

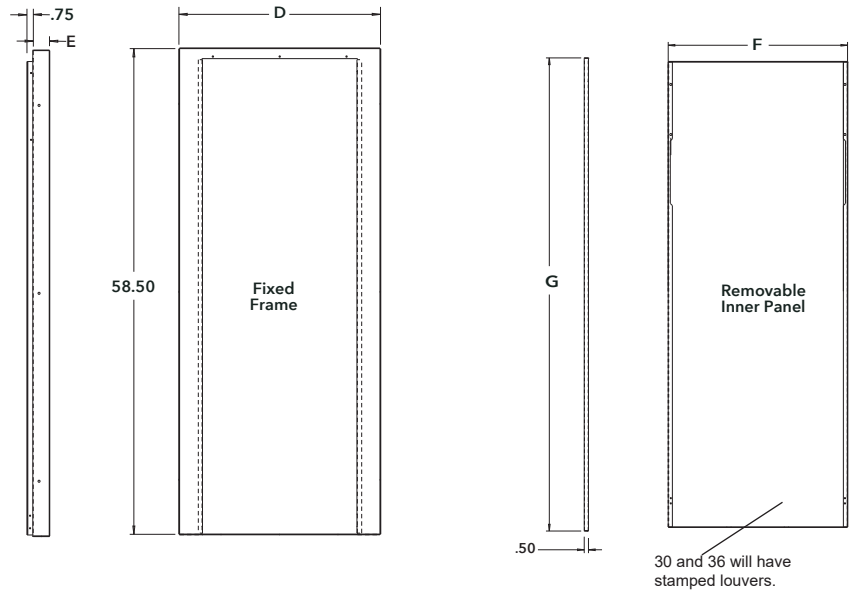

**NOTICE!**

Frame is attached to studs. Panel is removable for chassis access.

## Frame Installation

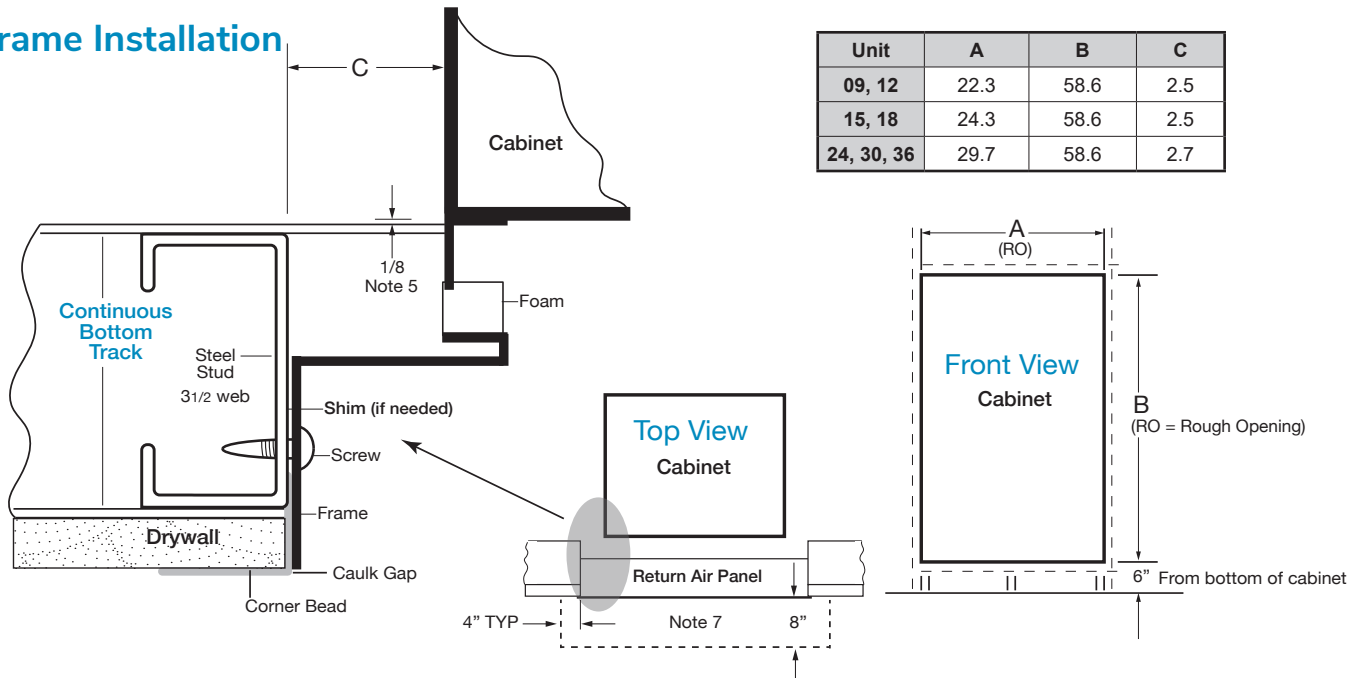

Unit	A	B	C
09, 12	22.3	58.6	2.5
15, 18	24.3	58.6	2.5
24, 30, 36	29.7	58.6	2.7

### Notes:

1. Dimensions are in inches.
2. Frame and panel painted Polar Ice or bright white.
3. Panel is removable for filter replacement or chassis removal.
4. Frame ships with cabinet—must be installed while framing.
5. Set bottom track 1/8" in front of cabinet.
6. Drywall mud is added to the corner bead to produce a smooth finished surface.
7. Unobstructed area for required air flow.

# Hose Kits and Stands

## AHU Series Hose Kit Specifications:

- AHU hose kits used for connection with ClimateMaster standard ball valves.
- Designed for vertical high rise water-source heat pump applications.
- Kevlar® reinforced EPDM core with ANSI 302/304 stainless steel outer braid.
- Fire rated materials per ASTM E 84-00 (NFPA 255, ANSI/UL 723 & UBC 8-1).
- Swivel connection provides union between chassis and riser shutoff.
- Brass fittings, stainless steel ferrules.
- Temperature range of 15°F [9°C] to 180°F [82°C]. (Operation below 32°F requires antifreeze)
- Max. working pressure of 400 psi [2756 kPa].
- Min. burst pressure of four times working pressure.

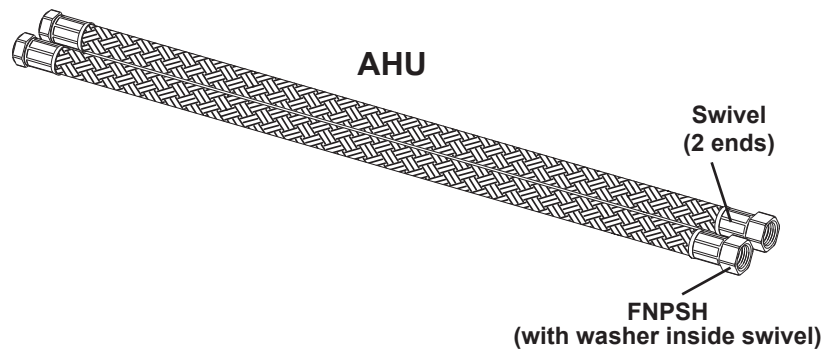

## Physical Data

Unit	Inside Diameter inches	Length feet [cm]	Working Pressure psi [kPa]	Min. Burst Pressure psi [kPa]	Min. Bend Radius inches [mm]
09 - 12	0.50	3 [91]	400 [2756]	1600 [11024]	2.5 [63.5]
15 - 18	0.75	3 [91]	400 [2756]	1600 [11024]	4.5 [114.3]
24 - 36	1.00	3 [91]	400 [2756]	1600 [11024]	5.5 [139.7]

## ACST Cabinet Stands

### Specifications

- 1" to 13" (25 to 330) tall, 1" (25) increments
- 16 Gauge galvanized steel
- Attached to cabinet with 4 screws
- Ships in bulk for field installation.
- Optional ISO pad 0.1" (2.5) thick

Unit	A	B	C
09-12	16.8 [427]	16.2 [411]	1 to 13 (25 to 330)
15-18	18.9 [480]	18.3 [465]	
24-36	23.9 [607]	23.3 [592]	

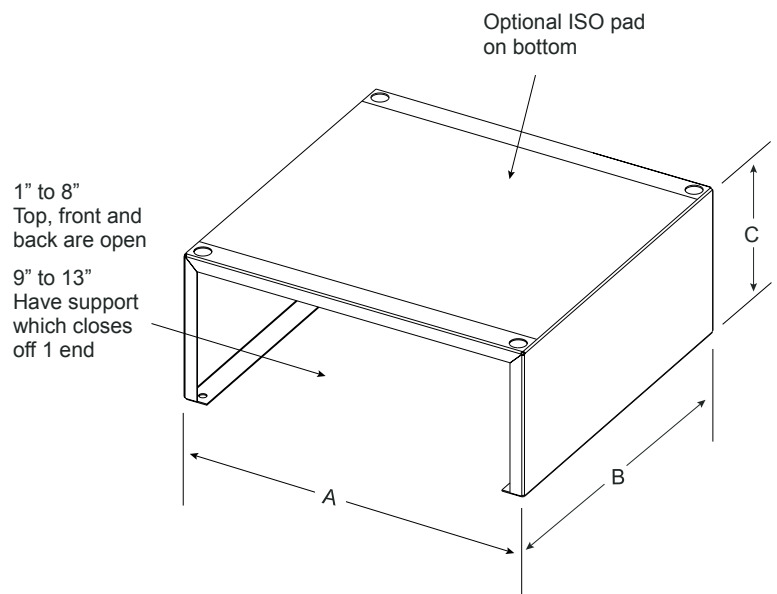

# Supply Air Openings and Grilles

## Supply Air K. O.'s in Cabinets

Cabinet Size	Cabinet Height	Front	Sides/Back	Top
C1, C2 (09, 12)	88	12 x 6 and 12 x 12		12 x 12
	80	12 x 6	12 x 6 and 12 x 12	
C3, C4 (15, 18)	88	14 x 6 and 14 x 14		14 x 14
	80	14 x 6	14 x 6 and 14 x 12	
C5, C7 (24, 36)	88	16 x 8 and 16 x 16		16 x 16
	80	16 x 6	16 x 6 and 16 x 12	

## Supply Air Grille Openings/Sq. In.

Cabinet Size	Number of Openings	Minimum Sq.in. Openings*	Recommended Sq.in. Openings
C1, C2 (09, 12)	1 or 2	144 (1 - 12 x 12) (2 - 12 x 6)	288 (2 - 12 x 12)
C3, C4 (15, 18)	1, 2, or 3	168 (1 - 14 x 12) (2 - 14 x 6)	392 (2 - 14 x 14)
C5, C7 (24, 36)	2 or 3	384 (2 - 16 x 12)	512 (2 - 16 x 16)

\* Less than minimum Sq. In. opening will have higher sound levels than published

Nominal Grille Size	Double Deflection Free Area (Sq. Ft)		
	Deflection 0°	Deflection 22 1/2°	Deflection 45°
12 x 6	.30	.28	.22
12 x 12	.65	.59	.48
14 x 6	.40	.38	.33
14 x 12	.80	.71	.55
14 x 14	.95	.86	.70
16 x 8	.61	.55	.44
16 x 12	.93	.85	.68
16 x 16	1.25	1.12	.90

### Notes:

1. When selecting supply air openings/grilles consider CFM, velocity (throw), added static pressure and sound.
2. Other sizes available as special.
3. If custom grille sizes are used - area should be greater or equal to above.
4. If using more than recommended number of opening, total CFM may be reduced or be unstable (PSC or ECM Motor).
5. If only top is used, suggest using TSL which are shorter cabinets so that duct will have more space to be designed for static regain.



# Supply Air Openings and Grilles

Grilles are shipped loose for field installation after drywall has been finished. Grilles are offered in three different styles, brushed aluminum, painted polar ice or painted bright white to match the return air door standard colors. Overall dimensions - add 1.25 (32) to nominal dimensions.

## A816GA Series Grilles

**Single Deflection** - Adjustable vertical blades for controlling horizontal path of discharge air (Left/Right).

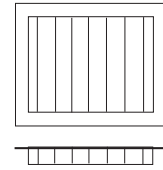

## A816GB Series Grilles

**Double Deflection** - Adjustable vertical and horizontal blades for controlling horizontal and vertical path of discharge air. (Left/Right and Up/Down) Recommended for all standard applications.

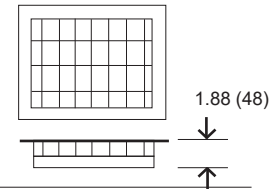

## A816GC Series Grilles

**Double Deflection with Opposed Blade Damper** - Addition of opposed blade damper to grille allows control of air volume (CFM) and path of discharge air. Recommended for applications requiring unequal air flow or side discharge grille(s) with additional top discharge air opening.

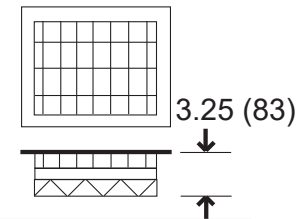

**Unequal Air Flow** - Air discharges requiring different air volumes (CFM). Use double deflection with opposed blade damper grilles.

**Top Discharge** - Units are designed to operate against relatively low air resistance (external static). Use of liberal duct sizing is recommended to maximize total unit air flow (CFM). Top duct outlet will offer more resistance to air flow than side outlets on the same cabinet. For top discharge only use TSL Series.

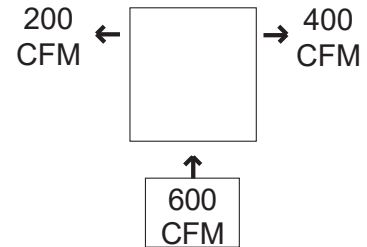

### ⚠ NOTICE! ⚠

Top air discharge units will require turning vanes and/or a volume damper for proper air flow and balancing, to minimize turbulence. These components must be field furnished and installed in accordance with SMACNA guidelines.

# Thermostats

Whether you're on a tight budget or have interest in the latest technology we have many types of thermostats to meet your project needs. Check out the details of our full thermostat product offering at <https://www.climatemaster.com/commercial/products/thermostats-and-accessories>.

Standard thermostats ship stand-a-lone and require field labor to make wiring connections on thermostats. ClimateMaster's A91558 Series adds a 6" whip factory assembled to the thermostat on one end with a 9-pin electrical quick connector on the other end. This is designed

for remote thermostat location applications. Cabinets can be order with 15', 25', or 35' remote thermostat whips. These whips come with the matching 9-pin electrical connector so thermostats can be quickly and easily installed in the field.

Customer supplied thermostats should be approved by ClimateMaster Engineering Department prior to using.

Below are a few examples of how thermostats are wired. Please see TSM and thermostat IOMs for full details.

## Wiring:

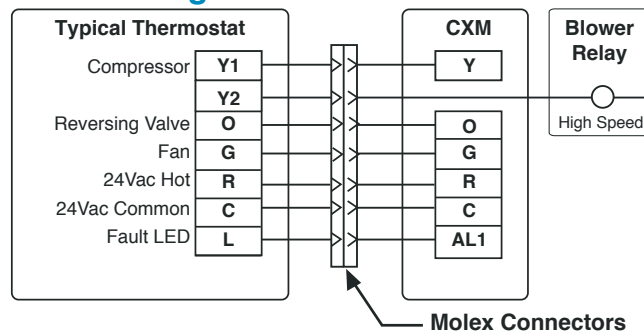

## Wiring:

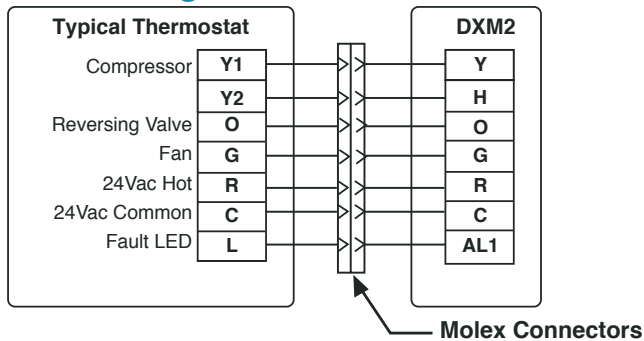

## Wiring:

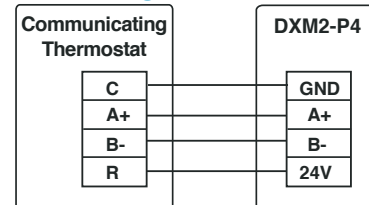

**Note:** Order chassis for communicating thermostat or field rewire.

Thermostat Assembly with Molex Connector 6" Pigtail	Thermostat Only+	Remote	Surface	ADA	CXM	DXM	Manual Changeover	Automatic Changeover	Programmable	Digital	Fault Indicator	Setback Override	Fan Speeds	Wi-Fi	Wireless remote temp. sensor
A9155801	ATA11U01	X	X	X	X	X	X	X	-	X	X	-	1	-	-
A9155802	ATA11U03	X	X	X	X	X	X	-	-	X	-	-	2*	-	-
A9155804	ATA22U01	X	X	X	X	X	X	X	-	X	X	-	2**	-	-
A9155809	ATP21W02	-	-	X	X	X	X	X	X	X	X	-	1	-	-
A9155810	ATP21W02	-	X	-	X	X	X	X	X	X	X	-	1	-	-
A9155811	ATP21W02	X	-	-	X	X	X	X	X	X	X	-	1	-	-
A9155805	ATP32U03C	X	X	X	X	X	X	X	X	X	X	X	2**	-	-
A9155806	ATC32U02C	X	X	X	X	X	X	X	X	X	X	X	2**	-	-
A9155813	ATA32V01	X	X	X	X	X	X	X	-	X	-	X	2**	-	-
A9155814	AVB32V02C	X	X	X	X	X	X	X	X	X	X	X	2**	X	X
A9155815	AVB32V03C	X	X	X	X	X	X	X	X	X	X	X	2**	X	X

\*Fan speed change automatic through thermostat Y2 signal.

\*\* - Manual speed change

Note: A9155809 for ADA, A9155811 for Remote Mount.

# Thermostats



## CM 500 (AVB32V03C)

5.25" w x 4" h x 1.1" d

- 7-day Programmable
- Wi-Fi Enabled
- Color Touch Screen
- Humidity control
- For use with water source heat pumps
- Mobile and web apps available for remote monitoring
- California Title 24 compliant

## CM 300 (AVB32V02C)

3.2" w x 3.2" h x 0.9" d

- 7-day Programmable
- Wi-Fi Enabled
- Humidity control
- For use with water source heat pumps
- Mobile and web apps available for remote monitoring
- California Title 24 compliant

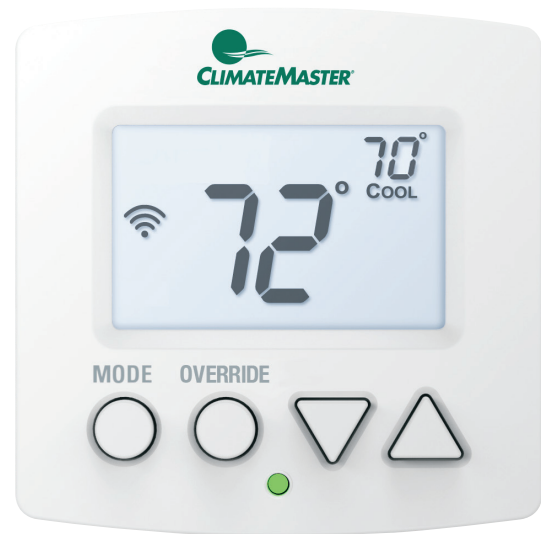

## CM 100 (ATA32V01)

3.1" w x 3.1" h x 1.0" d

- Auto Changeover - Automatically switches between cooling or heating
- LED indicator light glows green or red to indicate cooling or heating
- Can control temperature to within 1° of set point
- 3-stage heating and 2-stage cooling for use with heat pump
- All programming and set points stored in nonvolatile memory
- Key pad Locking - set points can only be adjusted by authorized individuals when this feature is on
- Large number display, extremely easy to operate and program



# TSM Cabinet Options

## Optional Cabinet Disconnect Switch (Non Fused)

Located on control box access door. Can be accessed through slot in "G" Panel Frame. Classified as motor disconnect. See Cabinet decoder.

## Optional Cabinet Circuit Breaker

Located on control box access door. Can be accessed through slot in "G" Panel Frame. All 208/230V and 265V 15 and 20 amp classified as HACR breaker. 265V 25 amp and higher classified as supplemental breaker. See Cabinet decoder.

**Cabinet Construction for surface-mounted thermostat cabinet has pre-wired 2 x 4 x 1 7/8 deep electric box mounted for horizontal thermostat. Contractor must turn prior to dry walling if field-supplied vertical thermostat is used.** Wire harness ends with 9-Pin Molex quick connector for easy connection to A91558 Series thermostats or can be cut off. See Cabinet decoder.

## Optional Thermostat Wire Harness (WHIP)

Low voltage wire harness 15, 25, or 35 foot ending with 9-Pin Molex quick connector. Exits cabinet on top, left front corner. Thermostat cable is rated CL-2. See Cabinet decoder. Can be encased in BX conduit as special, contact factory.

## Optional Premium Seal

Located on cabinet filter panel, seal is upgraded to extruded rubber gasket for durability and long life.

## Optional 2" Filter

2" filter improves air filtration and reduces maintenance.

## Accessory Filters (Not available for every application - check blower table for ESP)

1" (25mm) thick, MERV 8, and MERV 11  
2" (50mm) thick, MERV 8, MERV 11, MERV 13

Accessory Filter ESP Table

Model	TSM with ECM Motor				Accessory Filter Initial ESP					
	Size	Max CFM	Max ESP	coil area sq ft	face velocity fps	Merv 8		Merv 11		Merv 13
						1"	2"	1"	2"	2"
C1	9	500	0.3	2.5	200	0.09	0.07	0.10	0.09	0.16
C2	12	500	0.3	2.5	200	0.09	0.07	0.10	0.09	0.16
C3	15	700	0.3	2.5	280	0.17	0.14	0.22	0.15	0.25
C4	18	800	0.3	2.5	320	0.20	0.16	0.29	0.19	0.28
C5	24	950	0.3	3.4	280	0.17	0.14	0.22	0.15	0.25
C6	30	1100	0.3	3.4	325	0.21	0.15	0.32	0.19	0.29
C7	36	1350	0.3	3.4	400	0.26	0.21	0.44	0.24	0.34

# Riser Definitions

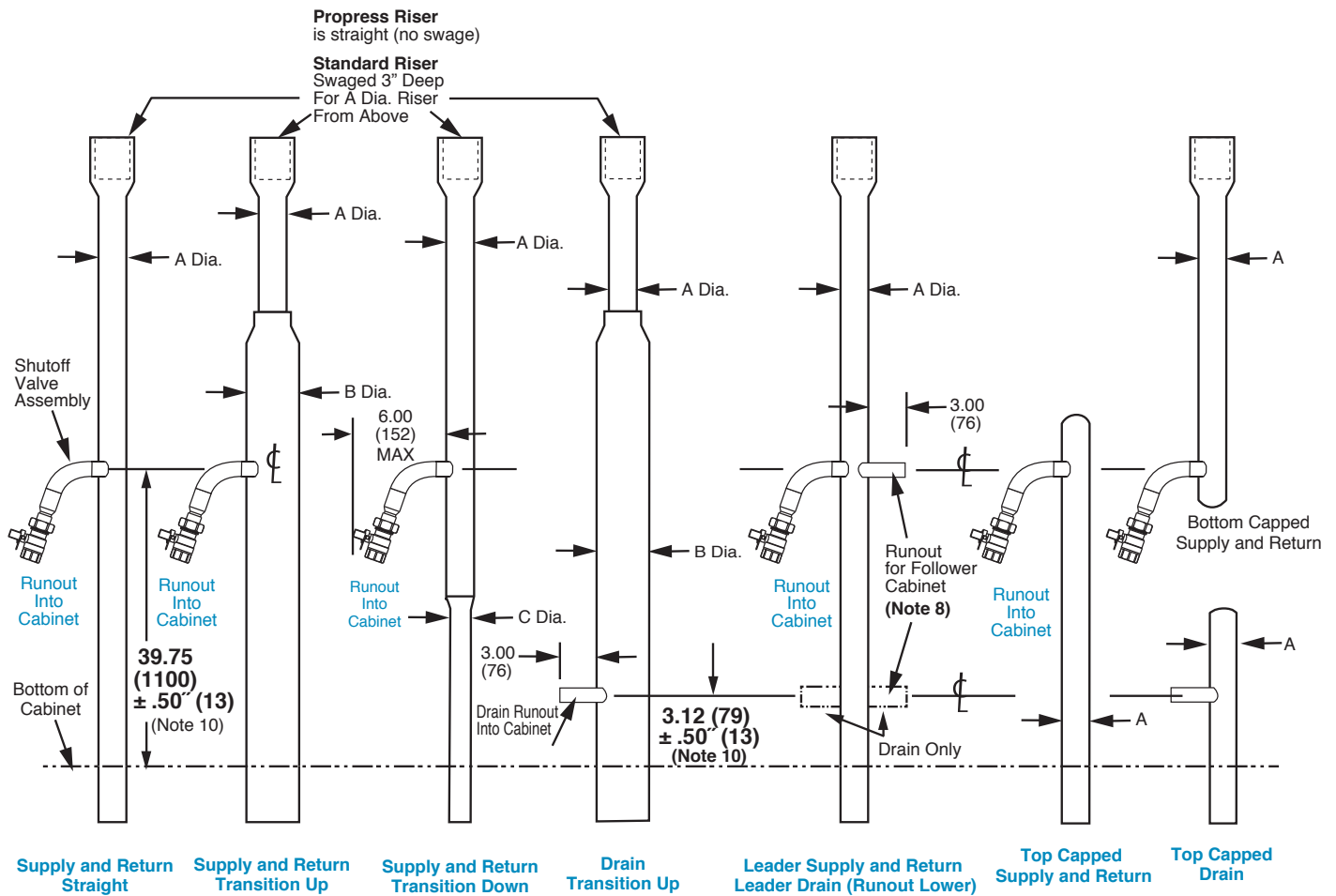

	Riser Diameter (in)						
A	1.00	1.25	1.50	2.00	2.50	3.00	4.00
B	1.25	1.50	2.00	2.50	3.00	-	-
C	-	1.00	1.25	1.50	2.00	2.50	-

## Notes:

1. You must know water flow direction to determine if cabinet requires transition up or down.
2. Transitions can only change by one diameter (1" to 1¼", 1¼" to 1½", etc.)
3. Riser transition couplings and run outs are factory brazed.
4. All risers are factory pressure tested.
5. Standard riser diameters are nominal 1", 1¼", 1½", 2", 2½", and 3". Please consult the factory on pricing for nominal 4" water tubing.
6. Copper Type M and L available (4" L only).
7. Drain riser insulated standard. Insulation is optional for supply and return
8. Leader riser - For follower cabinet riser ball valve assemblies, 12" of straight copper are provided for field connection to the leader riser. Assembly to be cut to length and field brazed. In applications where more than 12" of straight copper is needed, copper and fittings to be field provided.
9. Standard ball valves have NPSH threads for connection to AHU hoses (1/2" for C1 (09), C2 (12); 3/4" for C3 (15), C4 (18); or 1" for C5 (24), C6 (30), C7 (36)).
10. If cabinet stand or thick ISO pad is used, at installation add height/thickness to shutoff valve and drain run out height. Verify riser shutoff height with plans before brazing.

**Note: ClimateMaster units with motorized valve option have water high pressure switches. Do not design riser stack where switch will not reset (trip - 300 PSI; Reset - 250 PSI).**

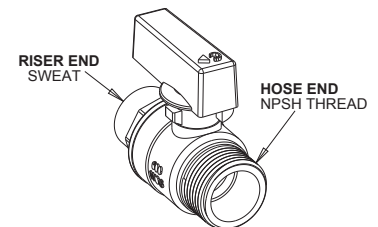

**Standard Valve**  
(Cabinet Digit 10 = 5)  
Used with AHU Style Hoses

# Riser GPM Definitions and Sizing

Riser GPM requirements and individual Unit GPM requirements are necessary to select the proper Riser Piping diameters. Refer to this page to determine GPM requirement, then refer to Riser Diameter Sizing Table to determine Riser Piping diameters.

Example is for bottom supply (upward flow) - bottom return (downward flow) system feed loop, both supply and return will be same GPM. GPM's are dependent upon unit load and system loop water temperatures. Please refer to Performance Charts for individual Unit GPM requirements.

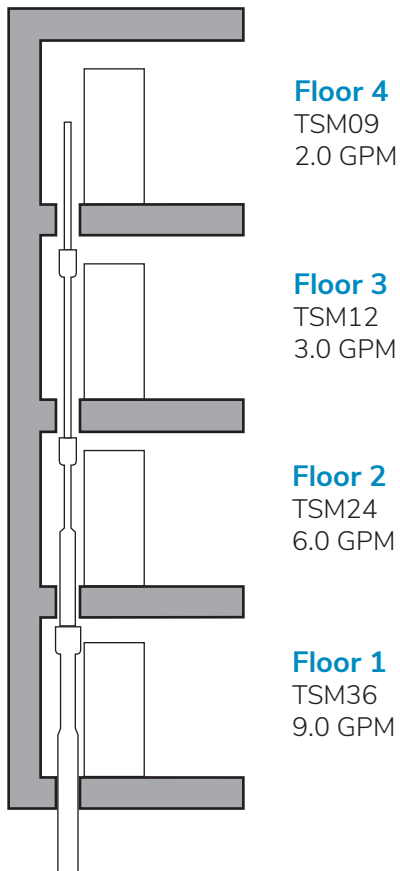

**Unit GPM (UGPM)** = Required gallons per minute from "Performance Charts," or GPM used to calculate unit capacity.  
**Note:** For factory installed AFR check Flow Rate available (See Table)

**Total Riser GPM (TRGPM)** = The total GPM's required for all units on each riser.

**Total GPM Per Floor (TGF)** = Total GPM minus the sum of Unit GPM from all floors above or below, depending on direction of flow.

**Example:** Four floors, Consisting of units sizes TSM36, TSM24, TSM12 and TSM09, as shown in diagram. UGPM's are 9.0, 6.0, 3.0 and 2.0 respectively.

**TRGPM** = 9.0 + 6.0 + 3.0 + 2.0 = 20 GPM.

## Upward Flow:

- Floor 1: TGF = 20 Add all floor GPM's (TRGPM).
- Floor 2: TGF = 11 Total GPM minus floor 1 GPM.
- Floor 3: TGF = 5 Total GPM minus floors 1 and 2 GPM's.
- Floor 4: TGF = 2 Total GPM minus floors 1, 2, and 3 GPM's.

## Downward Flow:

- Floor 4: TGF = 20 Add all floor GPM's (TRGPM).
- Floor 3: TGF = 18 Total GPM minus floor 4 GPM.
- Floor 2: TGF = 15 Total GPM minus floors 1 and 2 GPM's.
- Floor 1: TGF = 9 Total GPM minus floors 1, 2, and 3 GPM's.

Auto-Flow Regulator (US GPM) Code							
	5/8 Sweat		7/8 SWEAT				
	Unit 09	Unit 12	Unit 15	Unit 18	Unit 24	Unit 30	Unit 36
<b>C</b>	1.5	-	-	-	-	-	-
<b>D</b>	2.0	2.0	-	-	-	-	-
<b>E</b>	2.5	2.5	2.5	-	-	-	-
<b>F</b>	3.0	3.0	3.0	3.0	-	-	-
<b>G</b>	-	3.5	3.5	3.5	-	-	-
<b>H</b>	-	-	4.0	4.0	4.0	-	-
<b>J</b>	-	-	-	5.0	5.0	5.0	-
<b>K</b>	-	-	-	-	6.0	6.0	6.0
<b>L</b>	-	-	-	-	7.0	7.0	7.0
<b>M</b>	-	-	-	-	-	8.0	8.0
<b>N</b>	-	-	-	-	-	-	9.0
<b>P</b>	-	-	-	-	-	-	10.0

# Riser Diameter Sizing

Refer to Riser GPM Definitions and Sizing for the prefix to this example.

Each TSM Vertical Stack unit has three riser pipes: supply, return, and drain. The following example will be for Supply and Return riser pipe (from the top floor to the bottom floor), supply flow up and return flow down.

**Note:** If flows are both same direction, you will have to create two table 3's, Supply and Return

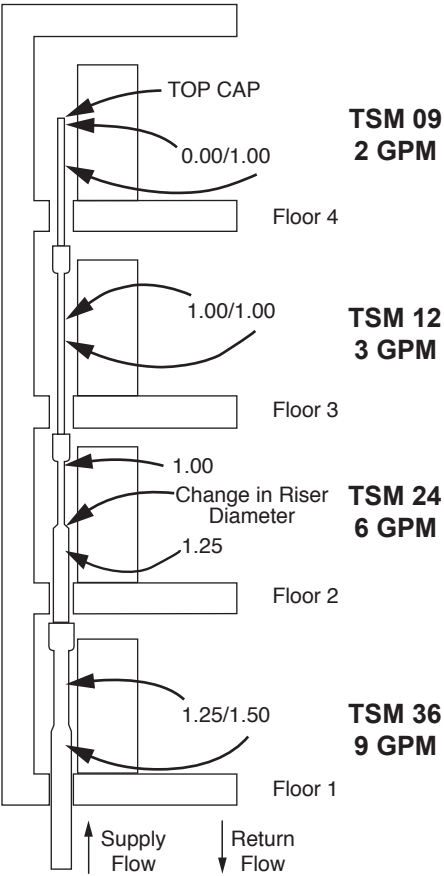

From Table 1 (below) determine the proper riser diameter needed to satisfy the required GPM's at each unit. Refer to Table 2 (below) for a summary.

**Top Cap** - Top half of riser is eliminated and sealed.  
**Bottom Cap** - Bottom half of riser is eliminated and sealed.

The following nomenclature is used to designate the diameters at the top (always first) and bottom of each unit.

- 0.00/1.00** - Indicates top cap/1" bottom.
  - 1.00/1.00** - Indicates 1" top/bottom.
  - 1.00/1.25** - Indicates 1" top/1.25" bottom.
  - 1.25/1.50** - Indicates 1.25" top/1.50" bottom.
- (from this we develop Table 3)

**Note:** Transition risers limited to 1 nominal diameter size larger or smaller within each floor (cabinet).

**Table 1**

Maximum GPM	10	16	23	48	80	135	190
Nominal Riser Diameter	1"	1-1/4"	1-1/2"	2"	2-1/2"	3"	4"

Max GPM for 1" to 1½" sized for 4 FT per second velocity  
 Max GPM for 2" to 4" sized for 5.5 FT per second velocity

**Note:** Max GPM per NABB recommendation. Never exceed 6.5 FPS, excessive noise and abrasion will occur.

**Table 2**

Floor	TGF	Diameter From Table 1
4	2	1" [25.4]
3	5	1" [25.4]
2	11	1.25" [31.8]
1	20	1.50" [38.1]

**Table 3**

Nomenclature per Unit	Description
<b>0.00/1.00</b>	Top Cap, w/1" Bot Feed
<b>1.00/1.00</b>	1" Full Length Riser
<b>1.00/1.25</b>	1" Top, 1.25" to 1st Floor
<b>1.25/1.50</b>	1.25" Top, 1.50" Bottom

**Table 4 (From IMC-2012 Table)**

Drain Diameter	Max Tonnage
<b>1" [25 mm]</b>	40
<b>1¼" [32 mm]</b>	90
<b>1½" [38 mm]</b>	125
<b>2" [51 mm]</b>	250

Values from Table 3 are to be entered on the Riser Piping Schedule in the ClimateMaster Solution Center. Top diameter must match bottom diameter of floor above.

To calculate drain riser diameter, add up unit tonnage and use Table 4. Example has 6¾ tons, so 1" diameter is adequate.

ClimateMaster works continually to improve its products. As a result, the design and specifications of each product at the time of order may be changed without notice and may not be as described herein. Please contact ClimateMaster's Customer Service Department at 1-405-745-6000 for specific information on the current design and specifications. Statements and other information contained herein are not express warranties and do not form the basis of any bargain between the parties, but are merely ClimateMaster's opinion or commendation of its products. The latest version of this document is available at [climatemaster.com](http://climatemaster.com). © ClimateMaster, Inc. All rights reserved 2013

# Swage Riser Length Definitions and Sizing

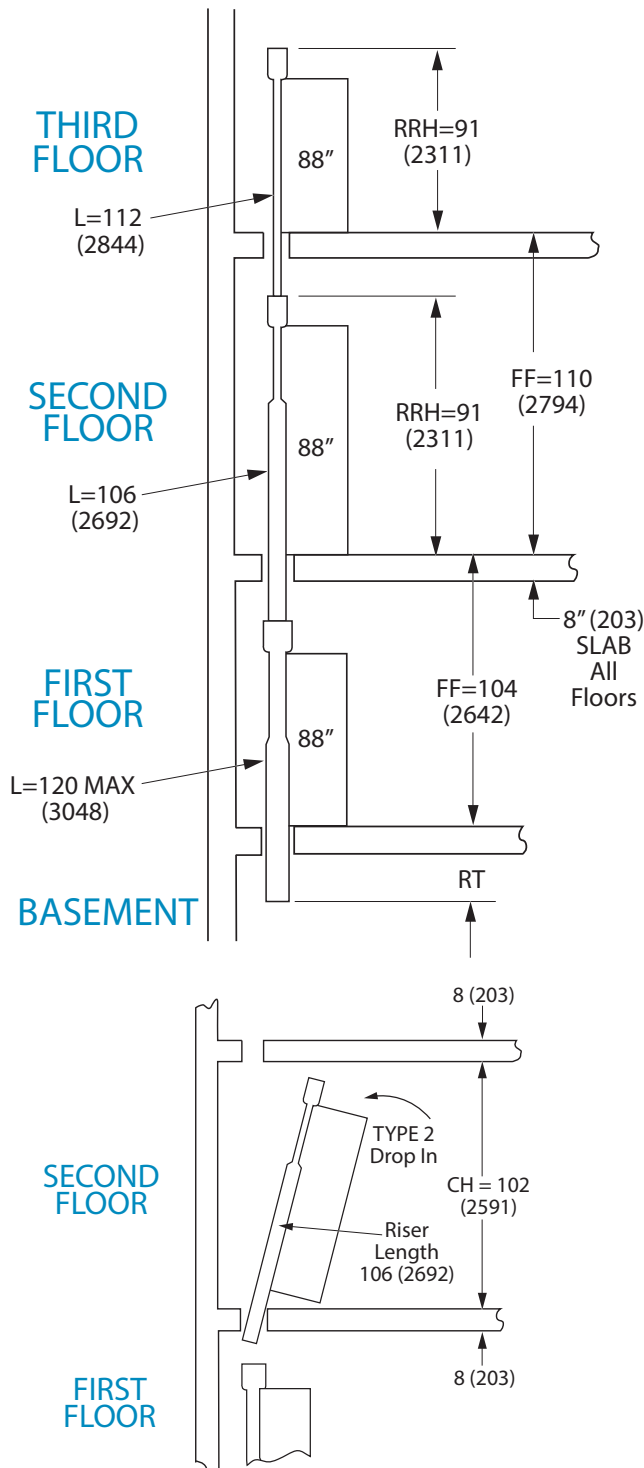

**Total Riser Length (L) for same height cabinets on every floor** = FF of floor below + 2" (51)

**Note:** If cabinet heights are mixed then L must be calculated. (88", 80", or 65")

**Floor To Floor Height (FF):** Distance from top of unit slab to top of above slab.

**Room Riser Height (RRH):** Cabinet height + 3" (76).

**Riser Tail Piece (RT):** Length of riser extending down from the cabinet. Riser tail piece must extend a minimum of 5" (127) below slab.

**Slab thickness (ST):** Slab thickness plus and additional material added to slab prior to setting cabinets.

**Riser insertion into swage** = 2" (51)

## Example 1 - Calculating Riser Length

### SECOND FLOOR RISER LENGTH

Slab = 8" (203)  
Cabinet Height = 88" (2235)

Use FF from first floor  
 $L = FF + 2" (50) = 106 (2692)$   
RRH = 91 (2311)  
RT = 15 (381)

### THIRD FLOOR RISER LENGTH

Use FF from second floor  
 $L = 112 (2844)$   
RRH = 91 (2311)  
RT = 21 (533)

## Example 2 - Checking Length for drop in to confirm acceptable

$L = 106 (2591)$  TYPE 2 drop in  
Slab Slot = See slab slot chart for width and length.

Clear Height (CH) and Riser Length (L) are used to determine slab slot dimensions so riser will pass through slot without hitting ceiling.

$$CH = FF - ST$$

## Notes:

1. Always use bottom of cabinet for calculations. If optional stand is used, everything raises dimension of stand.
2. If riser maximum 120 (3048) is exceeded or RT is less than slab + 5" (127) must use extension, see riser extension sizing.
3. Complete all core drilling before setting cabinets, openings must be aligned and plumb.
4. Set from lowest floor up.
5. If risers are shipped separate they are bulk shipped. Can palletize risers by floor as special.
6. Secure riser stack to building structure and use expansion fittings as required.
7. For calculating and entering on Solution Center, use full length even if top or bottom is capped.
8. Dimensions are inches (mm).



# Swage Riser Extension Definitions and Sizing

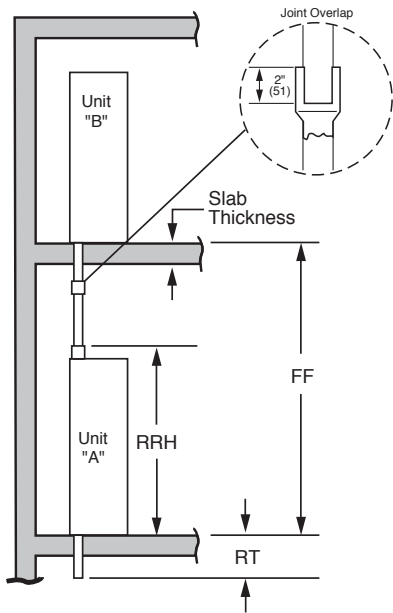

**Riser Extension Length:** Start with the floor to floor Dim. (FF) From this subtract the room riser height and tail piece length. Then add 4" (102) for the two joint overlaps.

**Riser Extension Length** = FF - (RRH + RT) + 4" (102). Minimum extension is 10" (254). Reduce riser length if needed.

**Riser Tail Piece (RT):** Length of riser extending down from the cabinet. Riser tail piece must extend a minimum of 5" (127) below slab.

**Room Riser Height (RRH):** Cabinet height + 3" (76).

**Floor To Floor Height (FF):** Distance from top of unit slab to top of above slab. Slab thickness (ST); Slab thickness plus and additional material added to slab prior to setting cabinets.

**Special care must be taken in sizing riser lengths and tail piece lengths when:**

- A) Riser extensions are used.
- B) Floor to floor heights vary.
- C) Slab thickness varies from floor to floor.

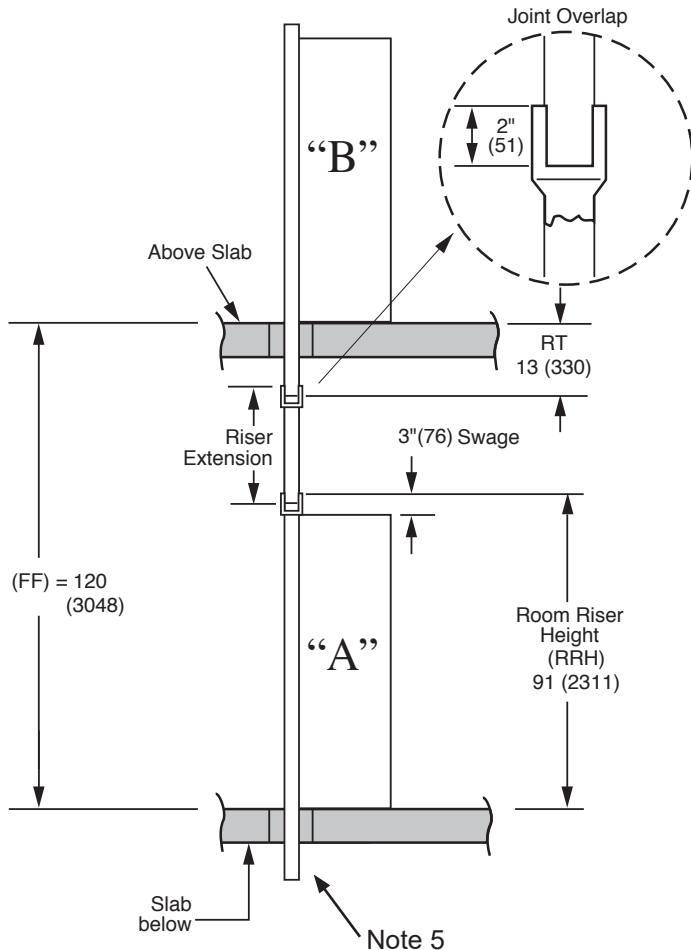

**Example:** Cabinet = 88

Floor to floor (FF) = 120" (3048)

Room Riser Height (RRH) = 91" (2311)

RT = 13" (330).

**Riser Extension:** 120" - (13" + 91") + 4" = 20".

3048 - (330 + 2311) + 102 = 508 mm.

**Notes:**

1. Example shown - riser extensions would be ordered with "A" and assembled between "A" and "B".
2. Riser "A" Top and Riser "B" bottom must be the same diameter. Extensions cannot transition.
3. Extensions are shipped loose, bulk shipped to minimize shipping cost.
4. Dimensions are inches (mm).
5. Any extension below "A" can be ordered as a factory special.

# Setting Cabinet

## Rotating Cabinet with Risers Into Position

To use the charts you will need the clear height of the room the unit is in, riser length, diameter, and type of installation. (See below)

### Type 1 Single Units

With a minimum clear height of 93" (2362). Start with the riser side down, lift and insert risers into slot, rotate upward, slowly pass risers through slot, set cabinet on floor.

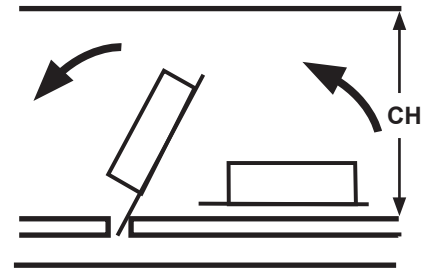

### Type 2 Single Units

With a minimum clear height of 95" (2413). Start with the side opposite of the risers down, lift and insert risers into slot, rotate upward, slowly pass risers through slot, set cabinet on floor.

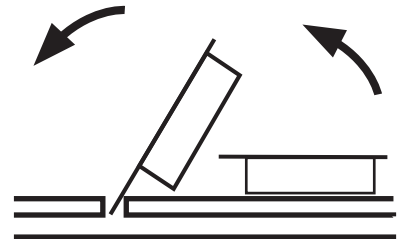

### Type 3 Single Units

With a minimum clear height of 94" (2388). Start with the risers on either side, lift and insert risers into slot, rotate upward, slowly pass risers through slot, set cabinet on floor.

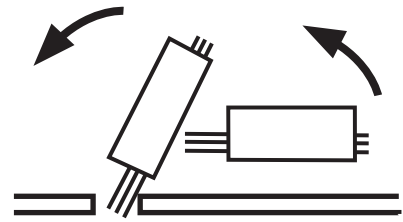

## ! NOTICE !

Before locating riser slab slot in floor, review plans and all information in this submittal regarding cabinet, risers, slab slot, rotation into slot, clear height and the relationship of all.

To determine the slab slot size required for the risers and to determine if clear height is OK for unit installation, use the example 2 on riser length page and slab slot charts on the next page.

# Slab Slot Chart – 3 Pipe

## Riser Stack Patterns



For Cabinet Styles 2 and 5

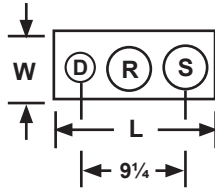

For Cabinet Styles 3 and 4

Clear Height is Floor to Ceiling Dimension

## Slab Slot for Cabinets w/Risers

Model	Clear Height		Riser length		Type of Installing Cabinet Through Slot					
					Type 1		Type 2		Type 3	
	in	mm	in	mm	in	mm	in	mm	in	mm
09-18	105	2667	115	2921	8 x 13 1/2	203 x 343	6 1/2 x 13 1/2	165 x 343	6 1/2 x 16	165 x 406
	100	2540	110	2794						
	98	2498	108	2743						
	96	2438	106	2692						
	95	2413	105	2667						
	94	2387	104	2641						
	93	2362	103	2616						
24-36	105	2667	115	2921	9 x 13 1/2	229 x 343	7 1/2 x 13 1/2	190 x 343	6 1/2 x 16 1/2	165 x 419
	100	2540	110	2794						
	96	2498	108	2743						
	95	2413	105	2667						
	94	2387	104	2641						
	93	2362	103	2616						

Chart dimensions for 3"(76.2) supply and return risers with insulation and 2" drain riser, 88" (2235)cabinet, and 8"(203) slab  
 Clear height is dimension from floor to ceiling. Riser length is clear height plus slab thickness plus 2" (50).  
 For 2" (50.8)risers setting by any Type 1, 2, or 3 reduce width by 1" (25) also Type 3 reduce length by 1" (25)  
 For 1" (25.4) risers setting by any Type 1, 2, or 3 reduce width by 2" (50) also Type 3 reduce length by 2" (50)  
 Opening centerline must be aligned from floor to floor  
 Contractor is responsible to meet all codes and regulations.

## Slab Hole if Risers Ship Loose and Installed Before Cabinet

Model	Clear Height		Riser Length		Riser Diameter					
					3	76.2	2	50.8	1	25.4
	in	mm	in	mm	in	mm	in	mm	in	mm
All	105	2667	115	2921	6 1/2	165	5 1/2	140	4 1/2	114
	100	2540	110	2794						
	96	2438	106	2692						
	95	2413	105	2667						
	94	2387	104	2641						
	93	2362	103	2616						

Dimensions for 8" (203) slab  
 Clear height is dimension from floor to ceiling. Riser length is clear height plus slab thickness plus 2" (50).  
 Opening centerline must be aligned from floor to floor  
 For risers over 100" (2540) using extensions with clear height equal to riser length or more, the hole size can be riser diameter plus 1" (25mm).  
 If riser diameter is not shown use next larger size.  
 Contractor is responsible to meet all codes and regulations.

# Shipping

## Units Are Shipped FOB Factory

### Chassis can be shipped in two ways,

1. Standing upright, chassis are packaged in a shipping carton and are shipped four chassis per pallet (See Figure 1).
2. Standing upright, chassis are shipped in the cabinet. The chassis cabinet combo are shipped four units per pallet. This shipping methodology reduces the number of freight pieces by 50%. This reduces freight costs, labor to remove shipping material, and dunnage removal expenses (See Figure 1).

### Cabinets can be shipped in two ways,

1. Standing upright, cabinets are packaged in shrink wrap and are shipped four cabinets per pallet (See Figure 1)
2. Laid horizontally with risers attached. Due to risers extending both below and above the cabinet anytime risers are attached to the cabinets horizontal shipping with the use of a flat bed truck is required. The number of cabinets per pallet can vary based on size and quantity mix (See shipping table 2 below). Pallets are shrink wrapped and a tarp is applied over the products for added protection during transit.

### Risers can be shipped in two ways,

1. Shipped horizontally attached to the cabinet. See cabinet shipping option 2 above for details
2. Shipped horizontally in a crate. Risers are crated by themselves and can be shipped independently from cabinets allowing for early installation. Risers shipping in a crate separately requires the use of a flat bed truck. The number of risers per pallet can vary based on diameter and quantity mix (See shipping table 3 below). Pallets are reinforced with a custom wood frame and packaging (See Shipping Figure 4 below).

Chassis, cabinets, and risers are palletized to maximize shipping density. The logic used for grouping is unit size by sales order.

Special shipping accommodations can be provided. Please see the Pre-Engineered factory design specials section for more details on this. Some examples include, palletizing by floor, palletizing by riser, end fork pallets, and reduced number of units per pallet.

Shipping Table 1

Description		Vertical Shipping								
		Size	Multi-pack			Qty Per Pallet	Multi-pack Weight (lbs)	Multi-pack Weight (kg)	Pallet Stacking	Approx. Qty Per 53' Box Trailer
			Length	Width	Height					
Chassis		09-12	41	41	50	4	430	195	2 High	240
		15-18	43	43	50	4	542	246	2 High	240
		24-36	53	53	52	4	786	357	2 High	192
Cabinets	No Supply Flanges	80" 09-12	41	41	87	4	478	217	1 High	112
		80" 15-18	43	43	87	4	558	253	1 High	112
		80" 24-36	53	53	87	4	722	328	1 High	72
	Supply Flanges Installed	80" 09-12	41	41	87	4	478	217	1 High	112
		80" 15-18	45	45	87	4	558	253	1 High	112
		80" 24-36	56	53	87	4	722	328	1 High	72
	No Supply Flanges	88" 09-12	41	41	95	4	534	242	1 High	112
		88" 15-18	43	43	95	4	618	281	1 High	112
		88" 24-36	53	53	95	4	782	355	1 High	72
	Supply Flanges Installed	88" 09-12	41	41	95	4	534	242	1 High	112
		88" 15-18	45	45	95	4	618	281	1 High	112
		88" 24-36	56	53	95	4	782	355	1 High	72
Chassis Shipped In Cabinets	No Supply Flanges	80" 09-12	41	41	87	4	886	402	1 High	112
		80" 15-18	43	43	87	4	1,078	489	1 High	112
		80" 24-36	53	53	87	4	1,482	672	1 High	72
	Supply Flanges Installed	80" 09-12	41	41	87	4	886	402	1 High	112
		80" 15-18	45	45	87	4	1,078	489	1 High	112
		80" 24-36	56	53	87	4	1,482	672	1 High	72
	No Supply Flanges	88" 09-12	41	41	95	4	942	427	1 High	112
		88" 15-18	43	43	95	4	1,138	516	1 High	112
		88" 24-36	53	53	95	4	1,542	700	1 High	72
	Supply Flanges Installed	88" 09-12	41	41	95	4	942	427	1 High	112
		88" 15-18	45	45	95	4	1,138	516	1 High	112
		88" 24-36	56	53	95	4	1,542	700	1 High	72

Shipping Height 85" for 80" cabinet and 93" for 88" cabinet  
Small and Large cabinets can be mixed on some loads

Shipping Table 2

Horizontal Shipping										
Description	Size	Multi-pack			Qty per Pallet	Multi-pack Approx. Weight (lbs)	Multi-pack Approx. Weight (kg)	Pallet Stacking*	Up to 110" Long Risers Approx. Qty Per 48' Flat Bed Trailer	111" to 120" Long Risers Approx. Qty Per 48' Flat Bed Trailer
		Length	Width	Height						
Cabinets	80" 09-12	127	53	87	8	1,600	726	2 High	60	48
	80" 15-18	127	53	93	8	1,600	726	2 High	60	48
	80" 24-36	127	63	76	6	1,600	726	2 High	45	36
	88" 09-12	127	53	87	8	1,600	726	2 High	60	48
	88" 15-18	127	53	93	8	1,600	726	2 High	60	48
	88" 24-36	127	63	76	6	1,600	726	2 High	45	36

\* Warehousing purposes only, pallets are shipped 1 High

Shipping Table 3

RISER SHIPPING									
Nominal Size (in.)	Pallet			# of Non-Insulated Layers per Pallet	# of Non-Insulated Risers per Pallet	# of Insulated Layers per Pallet	# of Insulated Risers per Pallet	Pallet Stacking	Qty Pallets Per 48' Flat Bed Trailer
	Length (in.)	Width (in.)	MAX Height (in.) *						
1	120	50	48	25	300	19	228	2 High	8
1.25	120	50	48	22	220	17	170	2 High	8
1.5	120	50	48	19	190	15	150	2 High	8
2	120	50	48	15	150	12	120	2 High	8
2.5	120	50	48	12	108	11	99	2 High	8
3	120	50	48	11	88	9	72	2 High	8
4	120	50	48	8	64	7	56	2 High	8

Calculations based on all palletted risers having the same nominal diameter size. Actual number of risers per pallet and number will vary based on riser diameter and insulation attachment mix.

\* Includes the top pallet piece, bottom pallet piece, 0.25" cardboard dividers between each layer, and 0.375" thick tubing insulation (if applicable)

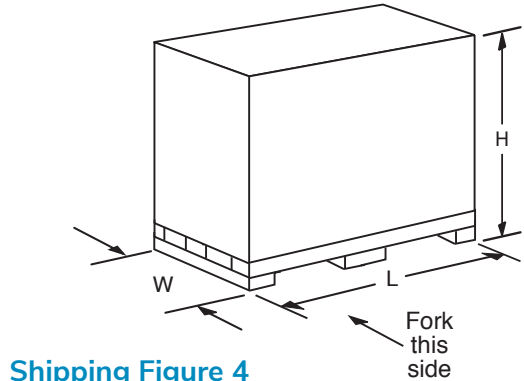
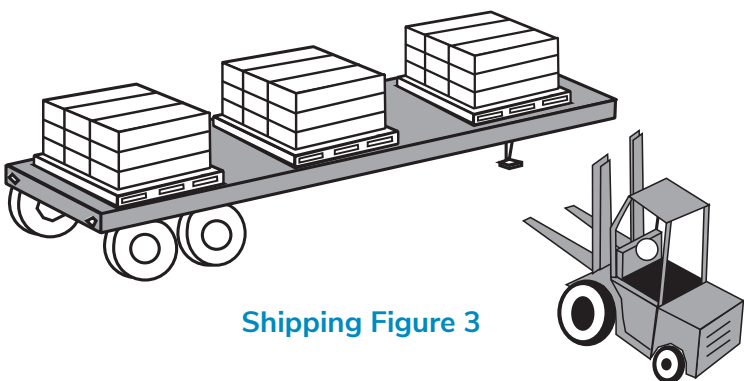
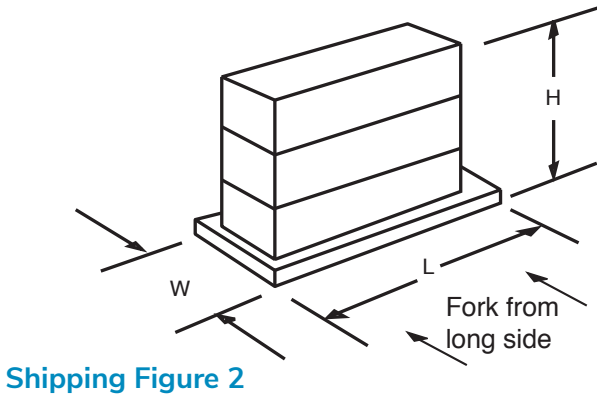
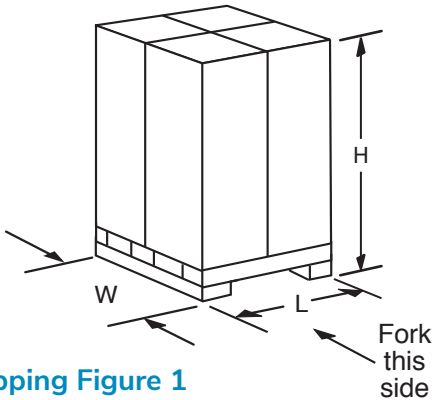

# Tranquility® Vertical Stack TSM Series Engineering Specifications – Page 1

## General:

Furnish and install ClimateMaster Tranquility® “TSM Vertical Stack” Water Source Heat Pumps, as indicated on the plans with capacities and characteristics as listed in the schedule and the specifications that follow.

Units shall be supplied completely factory built capable of operating over an entering water temperature range from 20° to 120°F (-6.7° to 48.9°C) as standard. Equivalent units from other manufacturers may be proposed provided approval to bid is given 10 days prior to bid closing. All equipment listed in this section must be rated and certified in accordance with Air-Conditioning, Heating and Refrigeration Institute/International Standards Organization (AHRI/ISO 13256-1). All equipment must be tested, investigated, and determined to comply with the requirements of the standards for Heating and Cooling Equipment UL-1995 for the United States and CAN/CSA-C22.2 NO.236 for Canada, by Intertek Testing Laboratories (ETL). The units shall have AHRI/ISO and ETL-US-C labels.

All units shall pass a factory acceptance test. The quality control system shall automatically perform the factory acceptance test via computer. A detailed report card from the factory acceptance test shall ship with each unit. **(Note: If unit fails the factory acceptance test, it shall not be allowed to ship. Unit serial number shall be recorded by factory acceptance test and furnished on report card for ease of unit warranty status.)**

## Cabinet Construction:

The cabinet panels shall be fabricated from heavy gauge galvanized steel. The rigid one-piece cabinet assembly shall be constructed so that it is self-supporting, and can be installed prior to the chassis arrival, and to be able to avoid damage during construction. Cabinet shall have a full panel over the chassis opening for structural rigidity of the cabinet; **no “open” top or “open” bottom designs allowed.**

The cabinet base shall contain a secondary drain pan fully insulated with a pressure differential drain trap connected to the condensate riser pipe, and guide rails for the slide in refrigeration chassis. Drain pan to be rubber grommet mounted to provide isolation of chassis from the cabinet. Drain pan(s) shall be easily accessible for cleaning. All interior surfaces shall be lined with 1/2 inch (12.7 mm) thick, 1-1/2 lb/ft<sup>3</sup> (24 kg/m<sup>3</sup>) acoustic type fiberglass insulation. All insulation shall be foil faced and have exposed edges butted up to flanges to prevent the introduction of glass fibers into the air stream.

Standard insulation must meet NFPA Fire Hazard Classification requirements 25/50 per ASTM E84, UL 723, CAN/ULC S102-M88 and NFPA 90A requirements; air erosion and mold growth limits of UL-181; stringent fungal resistance test per ASTM-C1071 and ASTM G21; and shall meet zero level bacteria growth per ASTM G22. **Unit insulation must meet these stringent requirements or unit(s) will not be accepted.**

Standard is 1 inch (25 mm) filter holder with 1inch (25 mm) thick fiberglass throwaway filter.

**Option: 2 inch (50 mm) filter holder with 2 inch (50 mm) thick fiberglass throwaway filter.**

**Pre-Engineered Special: Integrated fresh air intake. Removes the need for field attachment of fresh air assembly. Does not increase the cabinet footprint. Available with cabinet side connection only.**

Cabinet arrangements shall allow placement of riser piping on any one of the three sides of the cabinet not used for the chassis access and air supply. All cabinets shall have supply air knockouts on all sides and top. Return air K.O. to be removed from panel behind the filter. Field shall configure cabinets by removing factory knockouts and install duct flanges per model configuration shown on plans. For air noise attenuation purposes, the discharge air from fan shall discharge into insulated plenum that also contains x-shape painted air baffle. Units not having supply air noise baffles are not acceptable. Cabinet design shall allow a full height base board (4.50 inches/114 mm) beneath the return air “G” panel. The cabinet shall contain an easily removable motor/blower assembly.

# Tranquility® Vertical Stack TSM Series Engineering Specifications – Page 2

**Option:** Factory to configure supply air openings, remove K.O., cut insulation, and install duct angles. With dust protection, includes capping supply air openings and leaving K.O. in panel behind filter (installer to remove both).

Electrical conduit shall be installed from electrical unit control compartment to top of cabinet for low voltage control wiring as well as separate conduit for main power wiring. **Units without these two factory installed electric conduits will not be accepted.**

**Option:** Leader and follower cabinets.

**Option:** Required installation vibration isolation pad to be applied at the factory to the bottom of the cabinet if not field provided.

**Option:** Cabinet height 80" or 88" (203 or 223 cm)

**Pre-Engineered Special:** Extended cabinet heights

**Option:** Construction for unit mounted Thermostat (thermostat ordered separate) -- includes junction box mounted outside discharge plenum and has a Molex-type connector inside for quick connection to A91558 Series thermostat. The A91558 series use thermostat models ATA11U01, ATA11U03, ATA22U01, ATP21W02, ATP21W02, ATP21W02, ATP32U03C, ATC32U02C, ATA32V01, AVB32V02C, AVB32V03C respectively with mating molex-type connector.

**Pre-Engineered Special:** Custom thermostat whips for connection to 3rd party provided thermostats.

**Option:** Low voltage 15, 25, or 35 foot (572, 762, or 1,067 cm) wire harness (whip) with molex-type connector for connection to remote mounted thermostat. For use with A91558 thermostat series (see above).

**Pre-Engineered Special:** Extended thermostat whips for remote thermostat location in excesses of the 35' from the cabinet.

**Option:** Cabinet to have wire harness for connection to A91558 series thermostat mounted to ADA "G" return air panel.

**Option:** Premium automotive grade rubber seal between cabinet inner panel and chassis.

Full-length supply, return, and insulated condensate water risers shall be type M copper. Riser length up to 120 inch (305 cm) is standard. Supply and return risers have integral internal piping including ball valves (for shut off purposes at unit). Risers and piping shall be factory pressure tested to check for leaks. Field installed hose kits are required to connect the chassis piping to the cabinet ball valve. The condensate riser shall be insulated with 3/8-inch (9.5 mm) Armaflex type insulation. The top of each riser shall be deeply swaged (3 inch/76.2 mm) to accept connection to the riser above/below, allowing for a floor to floor dimensional variance of  $\pm$  one inch (25.4 mm). **Units not having swaged riser-piping connections shall not be acceptable. Couplings and trim pieces shall not be allowed.**

**Option:** Bulk ship risers so complete riser stack can be installed, pressure tested, and filled before the cabinets are installed.

# Tranquility® Vertical Stack TSM Series Engineering Specifications – Page 3

**Pre-Engineered Special:** Risers/Cabinets/Chassis shipped by floor. This helps with job site delivery coordination.

**Option:** Type L riser piping.

**Option:** Supply and return risers insulated with 3/8-inch (9.5 mm) ARMAFLEX (closed cell) type insulation. 1 inch through 3-inch diameter standard, 4-inch diameter available.

**Option:** Non-swaged riser piping for crimp (non-brazed) style connections.

**Pre-Engineered Special:** Risers for single pipe applications. Supply and return water lines are combined into one riser configuration.

**Pre-Engineered Special:** Riser connection location moved lower. Standard riser connections are made above the cabinets. This requires the use of a ladder or scaffolding to get access to the connection. Riser connection locations are moved lower so that connections can be made at the ground level. Risers must be shipped separately.

**Pre-Engineered Special:** Riser manual air vents. Allow for air to be purged from the riser stack during commissioning.

**Pre-Engineered Special:** Extended risers. Removes the need for riser extension pieces which results in less field connections.

**Pre-Engineered Special:** Remove drain riser. This is needed when condensate drain risers are field provided.

**Pre-Engineered Special:** Riser bypass valve. Allows water flow from supply to return riser during pressurization prior to the chassis being installed.

## **Fan and Motor Assembly:**

The cabinet shall contain a removable motor/blower assembly. Units shall have a direct drive centrifugal fan. The fan motor shall be 3 speed, permanently lubricated, PSC type with thermal overload protection. The fan motor for small size units (09 and 12) shall be isolated from the fan housing by a torsionally flexible motor mounting system with rubber type grommets to inhibit vibration induced high noise levels associated with “hard wire belly band” motor mounting. The fan motor on medium and large units (15-36) shall be isolated with flexible rubber type isolation grommets only. Airflow/External static pressure rating of the unit shall be based on a wet coil and clean filter. **Ratings based on a dry coil and/or no air filter shall not be acceptable.**

**Option:** ECM Constant Volume (CV) variable speed ball bearing type motor. The ECM-CV fan motor shall provide soft starting, maintain constant CFM over its static operating range and provide airflow adjustment in 25 CFM increments via its control board. The fan motor shall be isolated from housing by rubber grommets. The motor shall be permanently lubricated and have thermal overload protection. A special dehumidification mode shall be provided to allow lower airflows in cooling for better dehumidification. The dehumidification mode may be constant or automatic (humidistat controlled).



# Tranquility® Vertical Stack TSM Series Engineering Specifications – Page 4

**Option:** ECM Constant Torque (CT). The fan motor shall be isolated from housing by rubber grommets. The motor shall be permanently lubricated and have thermal overload protection.

## **Chassis:**

The chassis, which incorporates the air coil, water coil, drain pan with solid-state electronic condensate overflow protection, compressor, and electrical components shall be easily installed for quick job site installation and future servicing purposes. The slide in chassis shall have insulated panels surrounding the compressor. Compressors are not in the air stream. The chassis base shall be fabricated from heavy gauge galvanized steel formed to match the slide in rails of the cabinet. Units shall have a factory installed 1 inch (25.4 mm) thick filter bracket and throwaway type glass fiber filter. Furnish one spare set of filters.

**Option:** Chassis can ship upright in any cabinet that risers are not attached.

**Option:** UltraQuiet package shall consist of the standard double isolation of the compressor plus sound attenuating compressor blanket applied to the compressor. All sheet metal surrounding the compressor shall have high density sound attenuating material with STC rating of 26 per ASTM E-90 and then covered with fiberglass insulation.

**Option:** Factory wired for communicating thermostat, requires ATC32U02 thermostat.

**Option:** Rib relay replaces contactor for models 09 through 18. Eliminates contactor “click” when first energized.

**Option:** vFlow® The unit will be supplied with internally factory mounted modulating water valve with delta T control. The factory built-in valve shall modulate water flow through unit based on a field adjustable water temperature difference between the entering and leaving water. The valve shall automatically adjust for operating mode, source water temperature and variations in external head pressure. The valve will also act as a shut-off valve to prevent water flow through the unit when the unit is not activated and will have a minimum position capability.

**Option:** Factory installed 3-way water valve. Valves are used on units at the end of a riser water loop to ensure continuous flow between supply and return riser stacks when those units are not in operation. This prevents excessive water flow and pressure drop through the coax when it is not in operation.

**Pre-Engineered Special:** Internally factory mounted water loop strainer. Strainers filter water to ensure debris does not enter the unit coaxial heat exchanger. Debris in water loops can degrade thermal transfer (efficiency) and potentially limit water flow. Please consult TSM IOM for proper care and maintenance of strainers when selecting this option.

**Pre-Engineered Special:** Supply and Return P/T ports. Allows the for the water pressure drop to be checked across the heat exchanger which can be correlated to a fluid flow rate. Technicians can use this feature to determine if there is proper water flow through the unit.

**Option:** The unit will be supplied with internally factory mounted two-way motorized water valve (MWV) for variable speed loop pumping requirements. Valve to be fail closed type. Water circuit will have factory installed high pressure switch located between MWV and heat exchanger.

# Tranquility® Vertical Stack TSM Series Engineering Specifications – Page 5

**Option:** The unit will be supplied with internally factory mounted automatic water flow regulators.

**Option:** The unit will be supplied with internally factory mounted secondary pump rated for 200 PSIG applications.

Water connections between chassis and the cabinet shall be accomplished via a hose kit consisting of Kevlar-reinforced EPDM core hose surrounded by a stainless-steel braid. Hose kit shall have brass fittings with stainless-steel ferrules. AHH hose ends shall be solid External MPT which connects to mating fitting on cabinet shut off ball valve(s), and Internal NPSM (National Pipe Straight Mechanical) swivel end with fiber or EPDM washer which connects to mating threaded end connection on chassis. AHU hose ends shall be Internal NPSM (National Pipe Straight Mechanical) swivel end with fiber or EPDM washer which connects to mating threaded end connection on chassis. The hose kit shall be rated for 400 psi (2,756 kPa) design working pressure.

## Refrigerant Circuit:

All units shall contain an EarthPure® (HFC-410A) sealed refrigerant circuit including a high efficiency scroll or rotary compressor designed for heat pump operation, a thermostatic expansion valve for refrigerant metering, an enhanced corrugated aluminium lanced fin and rifled copper tube refrigerant to air heat exchanger, reversing valve, coaxial (tube in tube) refrigerant to water heat exchanger, and safety controls including a high pressure switch, low pressure switch (loss of charge), water coil low temperature sensor, and air coil low temperature sensor. Access fittings shall be factory installed on high- and low- pressure refrigerant lines to facilitate field service. Activation of any safety device shall prevent compressor operation via a microprocessor lockout circuit. The lockout circuit shall be reset at the thermostat or at the contractor supplied disconnect switch. **Units that cannot be reset at the thermostat shall not be acceptable.**

Hermetic compressors shall be internally sprung and externally isolated. The compressor shall have a dual level vibration isolation system. The compressor will be mounted on specially engineered sound-tested EPDM vibration isolation grommets to a large heavy gauge compressor base pan, which is then isolated from the cabinet by resting on condensate drain pan which is isolated by grommets for maximized vibration attenuation. All units (except units with rotary compressors) shall include a discharge muffler to further enhance sound attenuation. Compressor shall have thermal overload protection.

Refrigerant to air heat exchangers shall utilize enhanced corrugated lanced aluminium fins and rifled copper tube construction rated to withstand 625 PSIG (4309 kPa) refrigerant working pressure. Copper hairpins are tin electroplated for added protection from formicary corrosion. **Units that do not have tin-plated hairpins shall not be acceptable.**

Refrigerant to water heat exchangers shall be of copper inner water tube and steel refrigerant outer tube design, rated to withstand 625 PSIG (4,309 kPa) working refrigerant pressure and 500 PSIG (3,445 kPa) working water pressure. The refrigerant to water heat exchanger shall be "electro-coated" with a low cure cathodic epoxy material a minimum of 0.4 mils thick (0.4 – 1.5 mils range) on all surfaces. The black colored coating shall provide a minimum of 1,000 hours salt spray protection per ASTM B117-97 on all external steel and copper tubing. The material shall be formulated without the inclusion of any heavy metals and shall exhibit a pencil hardness of 2H (ASTM D3363-92A), crosshatch adhesion of 4B-5B (ASTM D3359-95), and impact resistance of 160 in-lbs (184 kg-cm) direct (ASTM D2794-93).

Refrigerant metering shall be accomplished by thermostatic expansion valve only. Expansion valves shall be dual port balanced types with external equalizer for optimum refrigerant metering. Units shall be designed and tested for operating ranges of entering water temperatures from 20° to 120°F (-6.7° to 48.9°C). Reversing valve shall be four-way solenoid activated refrigerant valve, which shall default to heating mode should the solenoid fail to function. If the reversing valve solenoid defaults to cooling mode, an additional low temperature thermostat must be provided to prevent over-cooling an already cold room.

# Tranquility® Vertical Stack TSM Series Engineering Specifications – Page 6

**Option:** The unit will be supplied with non-plated air to refrigerant heat exchanger.

**Option:** The unit will be supplied with cupro-nickel coaxial water to refrigerant heat exchanger.

## **Cabinet Drain Pan:**

The drain pan shall be constructed of galvanized steel and have a powder coat paint application to further inhibit corrosion. This corrosion protection system shall meet the stringent 1,000-hour salt spray test per ASTM B117. Drain pan to be isolated from cabinet with four EPDM vibration isolation grommets. If plastic type material is used, it must be HDPE (High Density Polyethylene) to avoid thermal cycling shock stress failure over the lifetime of the unit. Drain pan shall be fully insulated. Drain pan shall have at a minimum a doubled sloped surface to allow positive drainage to the outlet opening, which shall be at the lowest level of the entire pan surface. Drain outlet shall be connected from pan outlet to condensate riser (if supplied) with factory installed trap inside of cabinet. The cabinet drain pan as standard will be supplied with solid-state electronic condensate overflow protection. Drain pans that are not isolated from cabinet shall not be acceptable. Mechanical float switches will NOT be accepted.

**Option:** Stainless steel drain pan

## **Electrical:**

A control compartment shall be located within the chassis and shall contain a 50VA transformer, 24 volts activated, 2 pole compressor contactor, relay and solid-state controller for complete unit operation. Reversing valve and fan motor wiring shall be routed through this electronic controller. Units shall be name-plated for use with time delay fuses or HACR circuit breakers. Unit controls shall be 24 Volt and provide heating or cooling as required by the remote thermostat/sensor. A control compartment shall be located within the cabinet and shall contain a terminal block for high voltage connections. All electrical connections between the chassis and cabinet shall be made via locking quick-connects.

**Option:** Disconnect Switch, Non-Fused, classified as motor disconnect.

**Option:** Circuit Breaker, all 208/230 volt and 265 volt, 15 and 20 amp - HACR rated, 265-volt 25 amp and higher - supplemental rated.

## **Solid State Control System (CXM):**

Units shall have a solid-state control system. Units utilizing electro-mechanical control shall not be acceptable. The control system microprocessor board shall be specifically designed to protect against building electrical system noise contamination, EMI, and RFI interference. The control system shall interface with a heat pump type thermostat. The control system shall have the following features:

- a. Anti-short cycle time delay on compressor operation.
- b. Random start on power up mode.
- c. Low voltage protection.
- d. High voltage protection.
- e. Unit shutdown on high or low refrigerant pressures.
- f. Unit shutdown on low water temperature.
- g. Condensate overflow electronic protection.
- h. Option to reset unit at thermostat or disconnect.
- i. Automatic intelligent reset. Unit shall automatically reset the unit 5 minutes after trip if the fault has cleared. If a fault occurs 3 times sequentially without thermostat meeting temperature, then lockout requiring manual reset will occur.
- j. Ability to defeat time delays for servicing.
- k. Light emitting diode (LED) on circuit board to indicate high pressure, low pressure, low voltage, high voltage, low water/air temperature cut-out, condensate overflow, and control voltage status.

ClimateMaster works continually to improve its products. As a result, the design and specifications of each product at the time of order may be changed without notice and may not be as described herein. Please contact ClimateMaster's Customer Service Department at 1-405-745-6000 for specific information on the current design and specifications. Statements and other information contained herein are not express warranties and do not form the basis of any bargain between the parties, but are merely ClimateMaster's opinion or commendation of its products. The latest version of this document is available at [climatemaster.com](http://climatemaster.com). © ClimateMaster, Inc. All rights reserved 2013

# Tranquility® Vertical Stack TSM Series Engineering Specifications – Page 7

- l. The low-pressure switch shall not be monitored for the first 120 seconds after a compressor start command to prevent nuisance safety trips.
- m. 24V output to cycle a motorized water valve or other device when compressor relay is active.
- n. Unit Performance Sentinel (UPS). The UPS warns when the heat pump is running inefficiently.
- o. Water coil low temperature sensing (selectable for water or antifreeze).
- p. Air coil low temperature sensing.

**Units not providing the 8 safety protections of anti-short cycle, low voltage, high voltage, high refrigerant pressure, low pressure (loss of charge), air coil low temperature cut-out, water coil low temperature cut-out, leaving water high pressure switch, and condensate overflow protection for both drain pans will not be accepted.**

## Option: Enhanced Solid-State Control System (DXM2)

This control system is a communicating controller, also features two-stage control of cooling and two-stage control of heating modes for exacting temperature and dehumidification purposes.

This control system coupled with a multi-stage thermostat will better dehumidify room air by automatically running the heat pump's fan at lower speed on the first stage of cooling thereby implementing low sensible heat ratio cooling. On the need for higher cooling performance the system will activate the second stage of cooling and automatically switch the fan to the higher fan speed setting. This system may be further enhanced with a humidistat. **Units not having automatic low sensible heat ratio cooling will not be accepted; as an alternate a hot gas reheat coil may be provided with control system for automatic activation.**

This controller shall have sensors to monitor entering water, leaving water, supply air, and compressor discharge line temperatures. Temperatures can be read by using service tool or communicating thermostat.

Control shall have all the above-mentioned features of the CXM control system along with the following expanded features:

- a. Removable thermostat connector.
- b. Night setback control.
- c. Random start on return from night setback.
- d. Minimized reversing valve operation (Unit control logic shall only switch the reversing valve when cooling is demanded for the first time. The reversing valve shall be held in this position until the first call for heating, ensuring quiet operation and increased valve life.).
- e. Override temperature control with 2-hour timer for room occupant to override setback temperature at the thermostat.
- f. Dry contact night setback output for digital night setback thermostats.
- g. Ability to work with heat pump or heat/cool (Y, W) type thermostats.
- h. Ability to work with heat pump thermostats using O or B reversing valve control.
- i. Emergency shutdown contacts.
- j. Boiler less system heat control at low loop water temperature.
- k. Ability to allow up to 3 units to be controlled by one thermostat.
- l. Relay to operate an external damper.
- m. Ability to automatically change fan speed from multi-stage thermostat.
- n. Relay to start system pump.
- o. 75 VA control transformer. Control transformer shall have load side short circuit and overload protection via a built-in circuit breaker.

**Units not providing the 8 safety protections of anti-short cycle, low voltage, high voltage, high refrigerant pressure, low pressure (loss of charge), air coil low temperature cut-out, water coil low temperature cut-out, and condensate overflow protection for both drain pans will not be accepted.**

ClimateMaster works continually to improve its products. As a result, the design and specifications of each product at the time of order may be changed without notice and may not be as described herein. Please contact ClimateMaster's Customer Service Department at 1-405-745-6000 for specific information on the current design and specifications. Statements and other information contained herein are not express warranties and do not form the basis of any bargain between the parties, but are merely ClimateMaster's opinion or commendation of its products. The latest version of this document is available at [climatemaster.com](http://climatemaster.com). © ClimateMaster, Inc. All rights reserved 2013

# Tranquility® Vertical Stack TSM Series Engineering Specifications – Page 8

When DXM2 is connected to either ACDC service tool or ATC32U thermostat the installer/service technician can; check and set CFM; check dip switch S1, S2, and S3 settings; run operation modes manually; check all physical inputs from thermostat and refrigerant pressure switches status, (Y1, Y2, W, O, G, H, ESD, NSB, OR, HP switch, and LOC switch); current or at time of fault the following temperatures -LT1, LT2, compressor discharge, leaving air, leaving water, entering water and control voltage; record last five faults, list possible reasons, and clear faults.

## Digital Night Setback with Pump Restart (DXM2 w/ ATP32U03C/04C, ATC32U03C):

The unit will be provided with a Digital Night Setback feature using an accessory relay on the DXM2 controller with an ATP32U03/04 thermostat and an external, field-provided time clock. The external time clock will initiate and terminate the night setback period. The thermostat will have a night setback override feature with a programmable override time period.

An additional accessory relay on the unit DXM2 controller will energize the building loop pump control for the duration of the override period. **(Note: This feature requires additional low voltage wiring. Consult Application Drawings for details.)**

## Remote Service Sentinel (CXM/DXM2):

Solid state control system shall communicate with thermostat to display (at the thermostat) the unit status, fault status, and specific fault condition, as well as retrieve previously stored fault that caused unit shutdown. The Remote Service Sentinel allows building maintenance personnel or service personnel to diagnose unit from the wall thermostat. The control board shall provide a signal to the thermostat fault light, indicating a lockout. Upon cycling the G (fan) input 3 times within a 60 second time period, the fault light shall display the specific code as indicated by a sequence of flashes. A detailed flashing code shall be provided at the thermostat LED to display unit status and specific fault status such as over/under voltage fault, high pressure fault, low pressure fault, low water temperature fault, condensate overflow fault, etc. **Units that do not provide this remote service sentinel shall not be acceptable.**

## Option: MPC (Multiple Protocol Control) Interface System

Units shall have all the features listed above (either CXM or DXM2) and the control board will be supplied with a Multiple Protocol interface board. Available protocols are BACnet MS/TP, Modbus, or Johnson Controls N2. The choice of protocol shall be field selectable/changeable via the use of a simple selector switch. Protocol selection shall not require any additional programming or special external hardware or software tools. This will permit all units to be daisy chain connected by a 2-wire twisted pair shielded cable. The following points must be available at a central or remote computer location:

- a. Space temperature
- b. Leaving water temperature
- c. Discharge air temperature
- d. Command of space temperature setpoint
- e. Cooling status
- f. Heating status
- g. Low temperature sensor alarm
- h. Low pressure sensor alarm
- i. High pressure switch alarm
- j. Condensate overflow alarm
- k. Hi/low voltage alarm
- l. Fan "ON/AUTO" position of space thermostat as specified above
- m. Unoccupied/occupied command
- n. Cooling command
- o. Heating command
- p. Fan "ON/AUTO" command
- q. Fault reset command

# Tranquility® Vertical Stack TSM Series Engineering Specifications – Page 9

r. Itemized fault code revealing reason for specific shutdown fault (any one of 7)

This option also provides the upgraded 75 VA control transformer with load side short circuit and overload protection via a built-in circuit breaker.

## Return Panels:

The “G” return AR panel assembly shall be architecturally designed, acoustic type, with one-piece frame and hinged door for easy and quick access to filter. Assembly is attached to the cabinet with 4 bolts which can be easily removed for chassis access. The hinged return panel shall be made of heavy gauge die formed galvanized steel with a powder coat finish in “Polar Ice” or special color. Return air panels that protrude from wall more than 5/8 inch (15.9 mm) are not acceptable.

**Option:** Return air panel painted “Bright White” color

**Pre-Engineered Special:** Custom painting of return air panels per field specified color.

**Option:** “G” panel with mounting for ADA thermostat allows thermostat to be mounted low to comply with ADA height requirement.

**Pre-Engineered Special:** Custom return air panel knock outs for ADA mounted 3rd party provided thermostats.

**Pre-Engineered Special:** ADA return air panels with knock out moved lower. Needed when cabinets are placed on unit stands to comply with ADA maximum thermostat height.

**Option:** “G” panel with keyed locks - prevents users from tampering with units.

**Option:** Style “G” return air panel with frame for recessing cabinet behind finished wall.

**Option:** Motorized fresh air damper for “G” panel with frame - allows outside air to enter on right or left side.

**Option:** Flush Mounted “L” panel. Offered in Bright White and Polar Ice color option. Allows for chassis to be removed without removing the frame.

## Supply Grille(s):

Supply grille(s) shall be architecturally designed “brushed” aluminium or powder coated finish in “Polar Ice” color.

**Option:** Supply grille painted “Bright White”.

**Option:** Supply grille with double deflection style louvers.

**Option:** Supply grille with double deflection style louvers with opposed damper.

## Warranty:

ClimateMaster shall warranty equipment for a period of 12 months from start up or 18 months from shipping (which ever occurs first).

**Option:** Extended 4-year compressor warranty covers compressor for a total of 5 years.

ClimateMaster works continually to improve its products. As a result, the design and specifications of each product at the time of order may be changed without notice and may not be as described herein. Please contact ClimateMaster's Customer Service Department at 1-405-745-6000 for specific information on the current design and specifications. Statements and other information contained herein are not express warranties and do not form the basis of any bargain between the parties, but are merely ClimateMaster's opinion or commendation of its products. The latest version of this document is available at [climatemaster.com](http://climatemaster.com). © ClimateMaster, Inc. All rights reserved 2013

# Tranquility® Vertical Stack TSM Series Engineering Specifications – Page 10

**Option:** Extended 4-year refrigeration circuit warranty covers coils, reversing valve, expansion valve and compressor for a total of 5 years.

**Option:** Extended 4-year control board warranty covers the CXM/DXM2 control board for a total of 5 years.

## FIELD INSTALLED OPTIONS

### Hose Kits - (required for field water connections):

Water connections between chassis and the cabinet shall be accomplished via a hose kit consisting of Kevlar-reinforced EPDM core hose surrounded by a stainless-steel braid. Hose kit shall have brass fittings with stainless-steel ferrules. The hose kit shall be rated for 400 psi (2,756 kPa) design working pressure. This hose kit accessory is required for each cabinet, AHH for union cap valve and AHU for sweat valve.

### Cabinet Stands - ACST Series:

Cabinet stands are used when applications have baseboards with heights taller than 4 inches. Heavy 16-gauge galvanized steel construction, bolts to bottom of cabinet. Heights 1-inch (25 mm) to 13-inch (330 mm) by 1 inch (25 mm) increments. Ships in bulk for field attachment.

**Pre-Engineered Special:** Cabinet stands factory assembled and attached to the cabinet.

### Filters:

Pleated media disposable 1 inch (25 mm) thick MERV 8 or MERV 11, 2 inches (50 mm) thick MERV 8, MERV 11 or MERV 13.

### Thermostats:

The thermostat shall be a ClimateMaster electronic type thermostat as selected below with the described features:

**Note:** To achieve full benefit of controls, use 2 speed thermostats (switch for manual or Y2 for automatic change).

a. Multi-stage Digital Automatic or Manual Changeover Programmable Communicating (ATC32U02C)

Thermostat shall be electronic communicating LCD 7 Day Programmable (with up to 4 setpoints per day), thermostat shall be provided. The thermostat shall offer three stages of heating and two stages of cooling with precise temperature control and have a four-wire connection to the unit. The thermostat shall be capable of manual or automatic change-over operation and shall operate in standard or programmable mode. An integrated humidity control feature shall be included to control a humidifier and/or a dehumidifier. The thermostat shall include a utility demand reduction feature to be initiated by an independent time program or an external input. The thermostat shall have a comprehensive installation setup menu to include configuration of the unit CFM for each mode of operation (ECM motor option required). The thermostat shall display system faults with probable cause and troubleshooting guidance. Comprehensive service diagnostics menus shall display, system inputs, system outputs, configuration settings, Geo source inlet and outlet temperatures, compressor discharge line temperature, liquid line temperature, leaving air temperature. The thermostat shall allow for immediate manual control of all DXM2 outputs at the thermostat for rapid troubleshooting.

b. Single-Stage Digital Auto or Manual Changeover (ATA11U01)

Thermostat shall be a single-stage, digital, auto or manual changeover with HEAT-OFF-COOL-AUTO system switch and fan ON-AUTO switch. Thermostat shall have an LCD display with temperature and setpoint(s) in °F or °C. The Thermostat shall provide permanent memory of setpoint(s) without batteries. A fault LED shall be provided to display specific fault condition. Thermostat shall provide temperature display offset for custom applications.

# Tranquility® Vertical Stack TSM Series Engineering Specifications – Page 11

c. Single Stage Digital Auto or Manual Changeover and Manual Two Fan Speed Selections (ATA11U03)

Thermostat shall be a single-stage, digital, auto or manual changeover with HEAT-OFF-COOL-AUTO system settings, high and low fan settings and fan ON-AUTO settings. Thermostat shall have an LCD display with temperature, setpoint(s), mode, and status indication. The temperature indication shall be selectable for °F or °C. The thermostat shall provide permanent memory of setpoint(s) without batteries. Thermostat shall provide heating setpoint range limit, cooling setpoint range limit, temperature display offset, keypad lockout, dead-band range setting, and inter-stage differential settings. Thermostat shall allow the use of an accessory remote temperature sensor (17B0008N05). Thermostat navigation shall be accomplished via 4 push buttons.

d. Multi-stage Digital Automatic Changeover (ATA22U01)

Thermostat shall be multi-stage (2H/2C), manual or automatic changeover with HEAT-OFF-COOL-AUTO-EM HEAT system settings and fan ON-AUTO settings. Thermostat shall have an LCD display with temperature, setpoint(s), mode, and status indication. The temperature indication shall be selectable for °F or °C. The thermostat shall provide permanent memory of setpoint(s) without batteries. A fault LED shall be provided to indicate specific fault condition(s). Thermostat shall provide temperature display offset for custom applications. Thermostat shall allow unit to provide better dehumidification with optional DXM2 controller by automatically using lower fan speed on stage 1 cooling (higher latent cooling) as main cooling mode, and automatically shifting to high-speed fan on stage 2 cooling. Thermostat can be configured to heat and cool even if in off mode (replaces night low limit switch (NLLS) in cabinet).

e. Multi-stage Manual Changeover Programmable 5/2 Day (ATP21W02)

Thermostat shall be 5 day/2 day programmable (with up to 4 setpoints per day), multi-stage (2H/1C), manual or automatic changeover with HEAT-OFF-COOL-EM HEAT system settings and fan ON-AUTO settings. Thermostat shall have an LCD display with temperature, setpoint(s), mode, and status indication. The temperature indication shall be selectable for °F or °C.

f. Multi-stage Automatic or Manual Changeover Programmable 7 Day (ATP32U03C)

Thermostat shall be 7 day programmable (with up to 4 setpoints per day), multi-stage (3H/2C), automatic or manual changeover with HEAT-OFF-COOL-AUTO-EM HEAT system settings and fan ON-AUTO settings. Thermostat shall have a blue back lit dot matrix LCD display with temperature, setpoints, mode, and status indication. The temperature indication shall be selectable for °F or °C. Time display shall be selectable for 12 or 24-hour clock. Fault identification shall be provided (when used with ClimateMaster CXM or DXM2 controls) to simplify troubleshooting by providing specific unit fault at the thermostat with red back lit LCD during unit lockout. The thermostat shall provide permanent memory of setpoints without batteries. Thermostat shall provide heating setpoint range limit, cooling setpoint range limit, temperature display offset, keypad lockout, dead-band range setting, and inter-stage differential settings. Thermostat shall provide progressive recovery to anticipate time required to bring space temperature to the next programmed event. Thermostat shall provide an installer setup for configuring options and for setup of servicing contractor name and contact information. Thermostat shall allow the use of an accessory remote and/or outdoor temperature sensor (AST008C). Thermostat navigation shall be accomplished via five buttons (up/down/right/left/select) with menu-driven selections for ease of use and programming.

g. CM100 - Multi-stage Automatic or Manual Changeover digital thermostat (ATA32V01)

Multi-stage (3H/2C), automatic or manual changeover with HEAT-OFF-COOL-AUTO-EM HEAT system settings and fan ONAUTO settings. Thermostat shall have a green backlit LED display with temperature, setpoints, mode, and status indication via a green (cooling) or red(heating) LED. The temperature indication shall be selectable for °F or °C. Time display shall be selectable for 12- or 24- hour clock. The thermostat shall provide permanent memory of setpoints without batteries. Thermostat shall provide heating setpoint range limit, cooling setpoint range limit, temperature display offset, keypad lockout, dead-band range setting, and inter-stage differential settings. Thermostat shall provide progressive recovery to anticipate time required to bring space temperature to the next programmed event. Thermostat shall provide an installer setup for configuring. Thermostat navigation shall be accomplished via four buttons (Mode/fan/down/up) with menu-driven selections for ease of use and programming.



# Tranquility® Vertical Stack TSM Series Engineering Specifications – Page 12

- h. CM300 – Multi-stage, Automatic or Manual Changeover, 7-day Programmable with Wi-Fi and Humidity Control (AVB32V02C)  
Residential version shall be 7 day programmable with up to 4 setpoints per day. Commercial version shall be 7 day programmable with 4 occupied/unoccupied periods per day with up to 4-hour override. Multi-stage (3H/2C), automatic or manual changeover with HEAT-OFF-COOL-AUTO-EM HEAT system settings and fan ON-AUTO settings, Wi-Fi, pre-occupancy purge fan option, night time control of display backlight, bi-color LED indicates a heating or cooling demand, keypad lock, title 24 compliant, openADR2.0b certified with Skyport web portal. Compatible with condensate overflow warning systems – lockout compressor with message on.
- i. CM500 – Color Touchscreen Display, Multi-stage, Automatic or Manual Changeover, 7-day Programmable with Wi-Fi and Humidity Control (AVB32V03C)  
Thermostat shall have color resistive touchscreen display with space temperature, relative humidity, setpoints, mode, status indication and local weather (if connected to Wi-Fi). Residential version shall be 7 day programmable with up to 4 setpoints per day. Commercial version shall be 7 day programmable with 4 occupied/unoccupied periods per day with up to 4-hour override. Multi-stage (3H/2C), automatic or manual changeover with HEAT-OFF-COOL-AUTO-EM HEAT system settings and fan ONAUTO settings, Wi-Fi, pre-occupancy purge fan option, customizable screen saver and background displays, indicator on display indicates a heating or cooling demand, set-point lock, title 24 compliant, openADR2.0b certified with Skyport web portal. Compatible with condensate overflow warning systems – lockout compressor with message on the display. Capable of being monitored by 3rd party software. Compatible with AST014 Wi-Fi remote sensor. Configurator mobile app or web portal for easy setup. Separate dehumidification and humidification setpoints shall be configurable for discreet outputs to a dehumidification option and/or an external humidifier. The temperature indication shall be selectable for °F or °C. Time display shall be selectable for 12- or 24-hour clock. The thermostat shall provide permanent memory of setpoints without batteries. Thermostat shall provide heating setpoint range limit, cooling setpoint range limit, temperature display offset, dead-band range setting, and inter-stage differential settings. Thermostat shall provide progressive recovery to anticipate time required to bring space temperature to the next programmed event. Thermostat shall provide access to a web portal and mobile app for installer setup for configuring options. Thermostat shall have menu-driven selections for ease of use and programming.

## DDC Sensors:

ClimateMaster wall mounted DDC sensor to monitor room temperature and interfaces with optional DDC interface system described above. Several types as described below:

- a. Sensor only with no display (MPC).
- b. Sensor with setpoint adjustment and override (MPC only).
- c. Sensor with setpoint adjustment and override, LCD display, status/fault indication (MPC).

**NOTICE! This product specification document is furnished as a means to copy and paste ClimateMaster product information into project specification. It is not intended to be a complete list of product requirements. This document is an excerpt from the product submittal and must not be used without consulting the complete product submittal. For complete product installation and application requirements, please consult the complete product submittal. ClimateMaster is not responsible for misuse of this document or a failure to adequately review specific requirements in the product submittal.**

# Pre-Engineered Factory Design Specials

## In a fast pace ever changing market ClimateMaster is committed to working with our partners to bring solutions to their project challenges

and we do this in many ways. We design our products to be extremely configurable, offer the widest range of product options, continually introduce new options, and support special design modification requests. When unique solutions are needed to support your project specific needs, ClimateMaster is here to be your partner!

In our years of experience we have supported many different requests. Below is a list commonly requested (pre-engineered) factory design specials we support:

- **Cabinets stands factory assembled and attached to the cabinet** – Saves labor and time in the field
- **Extended height cabinets** – Reduced ducting material; Supply air is discharged at a higher elevation (lengths limited)
- **Integrated fresh air intake** – Conditioned outside air can be ducted directly to the cabinet without the need for a field accessory and without extending the cabinets footprint
- **Single pipe risers** – Supply and return riser combined into one riser for single pipe applications
- **Riser to riser connection points moved lower** – Allows for brazing connection to be made without the use of a ladder or scaffolding
- **Supply and Return P/T ports** – Allows for water pressure drop to be checked across the heat exchanger which can be correlated to a fluid flow rate
- **Riser manual air vents** – Allow air to be purged from the system at the top of a riser stack
- **Extended riser lengths** – Removes the needed for extension pieces (lengths limited)
- **Remove drain riser** – When drain risers are field provided
- **Riser bypass valve** – Allows water flow from supply to return riser during pressurization prior to the chassis being installed
- **4" Risers** – Applications that need large amounts of water flow
- **Risers/Cabinets/Chassis shipped by floor** – Helps with job site delivery coordination
- **Extended thermostat whips** – Same labor/time saving solution but needed when remote thermostats are located more than 35' away
- **Custom thermostat whips** – Used for connection to 3rd party provided thermostats
- **ADA return air panels with custom knocks outs** – Needed with 3rd party provided thermostats are mounted to our return air doors
- **Customer return air panel colors** – Supports Architect/Designer/Owner requests
- **Strainers** – Collect debris in the water loop stopping it from entering the water heat exchanger

These are just a few of the product modifications we have supported for applications specific needs. To inquire about any of these preconfigured special options or any other solutions you need support with on your vertical high-rise project please contact your local ClimateMaster Representative: <https://www.climatemaster.com/commercial/header-links/rep-locator>.

# Performance Sheet

## SUBMITTAL DATA - S-I UNITS

Unit Designation: \_\_\_\_\_

Job Name: \_\_\_\_\_

Architect: \_\_\_\_\_

Engineer: \_\_\_\_\_

Contractor: \_\_\_\_\_

## PERFORMANCE DATA

Cooling Capacity: \_\_\_\_\_ kW

EER: \_\_\_\_\_

Heating Capacity: \_\_\_\_\_ kW

COP: \_\_\_\_\_

Ambient Air Temp: \_\_\_\_\_ °C

Entering Water Temp (Clg): \_\_\_\_\_ °C

Entering Air Temp (Clg): \_\_\_\_\_ °C

Entering Water Temp (Htg): \_\_\_\_\_ °C

Entering Air Temp (Htg): \_\_\_\_\_ °C

Airflow: \_\_\_\_\_ l/s

Fan Speed or Motor/RPM/Turns: \_\_\_\_\_

Operating Weight: \_\_\_\_\_ (kg)

## ELECTRICAL DATA

Power Supply: \_\_\_\_\_ Volts

\_\_\_\_\_ Phase \_\_\_\_\_ Hz

Minimum Circuit Ampacity: \_\_\_\_\_

Maximum Overcurrent Protection: \_\_\_\_\_

## SUBMITTAL DATA - I-P UNITS

Unit Designation: \_\_\_\_\_

Job Name: \_\_\_\_\_

Architect: \_\_\_\_\_

Engineer: \_\_\_\_\_

Contractor: \_\_\_\_\_

## PERFORMANCE DATA

Cooling Capacity: \_\_\_\_\_ Btuh

EER: \_\_\_\_\_

Heating Capacity: \_\_\_\_\_ Btuh

COP: \_\_\_\_\_

Ambient Air Temp: \_\_\_\_\_ °F

Entering Water Temp (Clg): \_\_\_\_\_ °F

Entering Air Temp (Clg): \_\_\_\_\_ °F

Entering Water Temp (Htg): \_\_\_\_\_ °F

Entering Air Temp (Htg): \_\_\_\_\_ °F

Airflow: \_\_\_\_\_ CFM

Fan Speed or Motor/RPM/Turns: \_\_\_\_\_

Operating Weight: \_\_\_\_\_ (lb)

## ELECTRICAL DATA

Power Supply: \_\_\_\_\_ Volts

\_\_\_\_\_ Phase \_\_\_\_\_ Hz

Minimum Circuit Ampacity: \_\_\_\_\_

Maximum Overcurrent Protection: \_\_\_\_\_

# Revision History

Date:	Item:	Action:
3/24/22	Page 56	Added additional cabinet dimensions
9/28/21	All	Removed LON Controls
9/08/21	Page 61	Added RA Panel Dimensions
9/07/21	page 47	Added Return Air Filter Dimensions to Physical Data Table
8/25/21	page 16, 61	Introduced ADA Type 1/Type 2 Thermostat Mounting Table in the AVHS "G" Panel Decoder
3/22/21	Page 56	Updated Values for "C"
1/18/21	Page 17	Added Riser Decoder
1/08/21	Page 46, 62	Updated Physical Data and measurements
11/03/20	Page 77	Updated Engineering Specs
9/25/20	Page 59	Updated Notice, Images, and Notes
9/21/20	Page 60	Updated Table Data
9/18/20	All	Updated document verbiage/layout, added Pre-Engineered section, introduced 3-way water valve, DDC chassis controls options, and new thermostat options, new decoder format
3/12/19	Table Page 24	Updated Table Data
9/26/18	All	Reduced footprint of sizes 09-12. Introduced ECM-CT w CXM and Flush Return Panel "L"
7/17/18	All	Updated heating LAT
6/22/18	Revision Update	Reduced footprint of sizes 09-12. Introduced CT ECM w/CXM controls and added Flush Mounted Return Air Panel.
08/07/17	All	Updated information to new decoders
07/6/17	Cabinet and chassis decoders, 200 PSI pump, modulating water valve, and normally open valve	Updated
05/08/17	Hose Kit Decoder sweat shutoff valve	Updated
11/1/16	Update Document Design	Updated
04/19/16	Page 62,32	Text
03/8/16	Page 66	Edit Engineering specs
09/01/15	Removed Electric Heat and vFlow® Options	Updated
06/24/15	Engineering Specifications and Misc Text and Tables Modulating WV, Variable Pump, RIB Relay, Rev B	Updated
12/16/14	Edits - page 59	Updated
12/12/14	Table - page 37	Updated
11/11/14	Added ATP21W02 Thermostat, Electric Heat, iGate Options, Misc. Changes: Removed ATP21U01 Thermostat.	Updated
06/17/14	Vertical Shipping Table - page 62	Updated
06/05/14	Engineering Specifications	Updated
05/30/14	Table - page 28	Updated
05/28/14	Table, illustration and text - pages 52 & 64; Change DXM to DXM2 - All pages	Updated



A NIBE GROUP MEMBER

7300 S.W. 44th Street  
 Oklahoma City, OK 73179  
 Phone: 405-745-6000  
 climatemaster.com

ClimateMaster works continually to improve its products. As a result, the design and specifications of each product at the time of order may be changed without notice and may not be as described herein. Please contact ClimateMaster's Customer Service Department at 1-405-745-6000 for specific information on the current design and specifications. Statements and other information contained herein are not express warranties and do not form the basis of any bargain between the parties, but are merely ClimateMaster's opinion or commendation of its products. The latest version of this document is available at [climatemaster.com](http://climatemaster.com). © ClimateMaster, Inc. All rights reserved 2013