

ZY08, ZY09, ZX09 & ZX12 Cooling With Gas Heat (7.5 Through 10 Ton)

ZY08
 ZY09
 ZX09
 ZX12

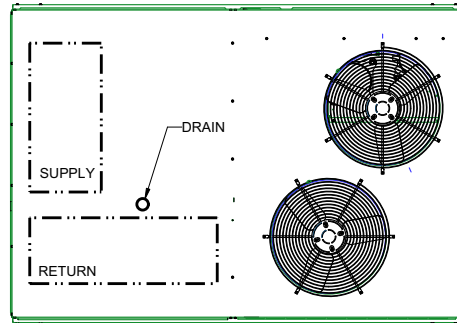

TOP VIEW

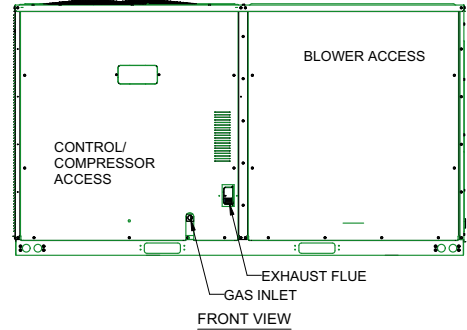

FRONT VIEW

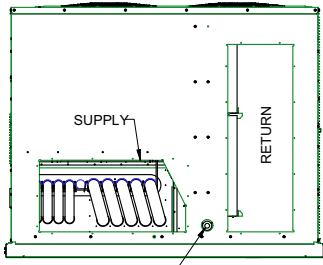

RIGHT VIEW

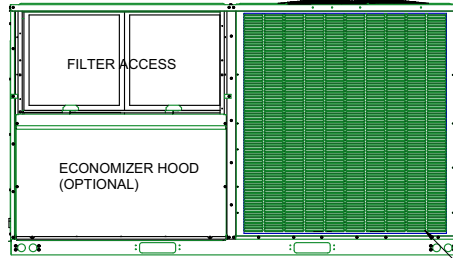

BACK VIEW

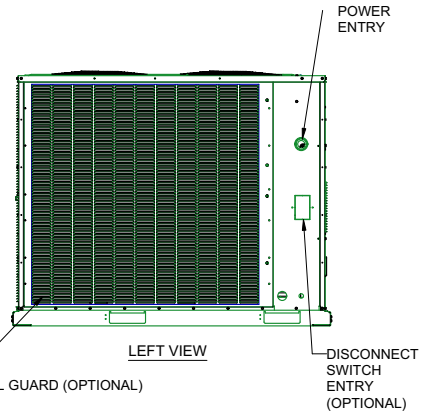

LEFT VIEW

FIGURE 1

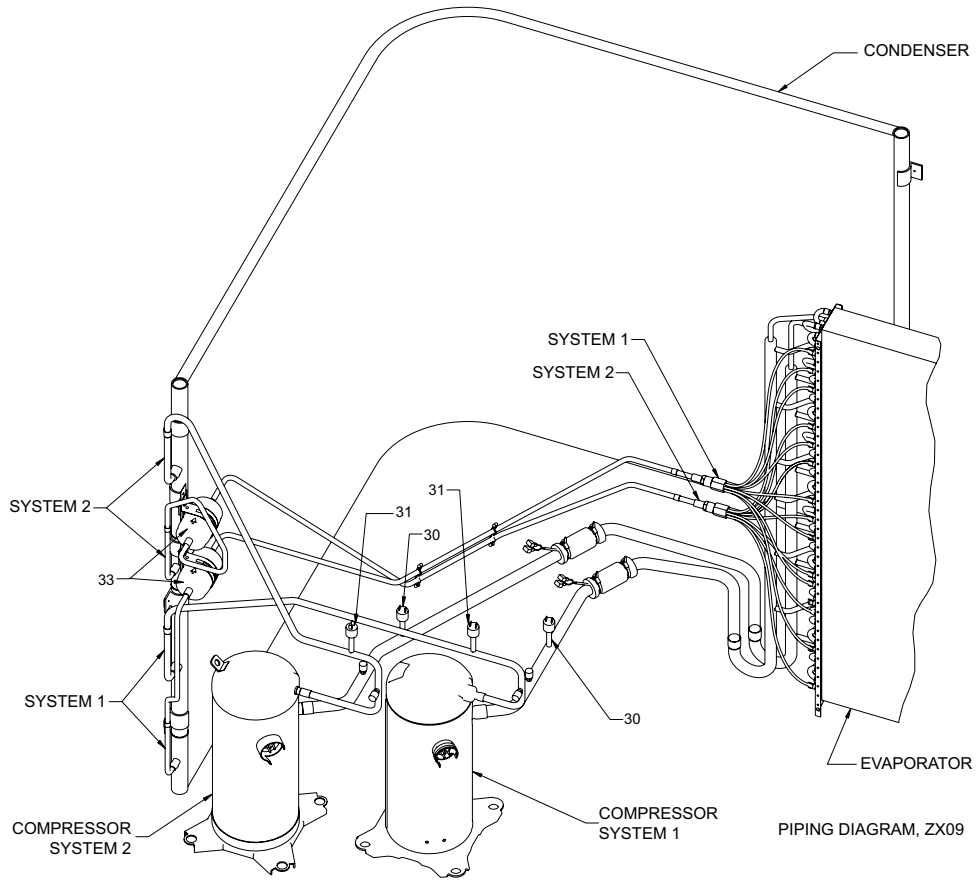

FIGURE 2

PIPING COMPONENTS ZX09 & ZX12

Item No.	See Figure	Description	Part Number	ZX09	ZX12
30	2	CNTRL,PRES,REFRIG,50/71(O/C) +/-5,SWEAT	S1-02435876000	2	2
31	2	CNTRL,PRES,REFRIG,650/450(O/C) PSIG	S1-02545253000	2	2
33	2	FILTER-DRIER,LIQUID 3/8 ODF,21 SQ IN	S1-52634088000	2	2
EVAPORATOR	2	COIL,EVAP,ZX09	S1-37335185000	1	
	2	COIL,EVAP,ZX09,ELECTROFIN	S1-37335185300	1*	
	2	COIL,EVAP,ZX12	S1-37335186000		1
	2	COIL,EVAP,ZX12,ELECTROFIN	S1-37335186300		1*
CONDENSER	2	COIL,COND,FORM,MC,25MM X 44,LFT	S1-32647163000	1	1
	2	COIL,COND,FORM,MC,25MM X 44,LFT, ELECTROFIN	S1-32647163300	1*	1*

*. OPTIONAL E-FIN COATING

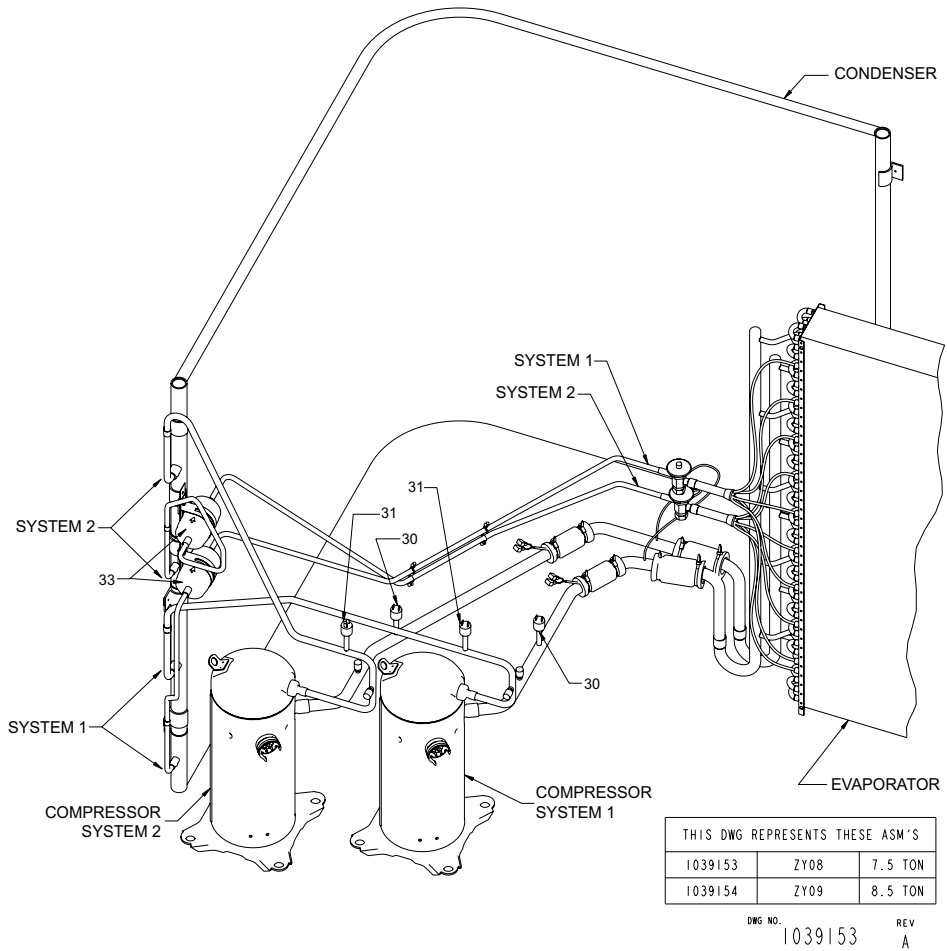
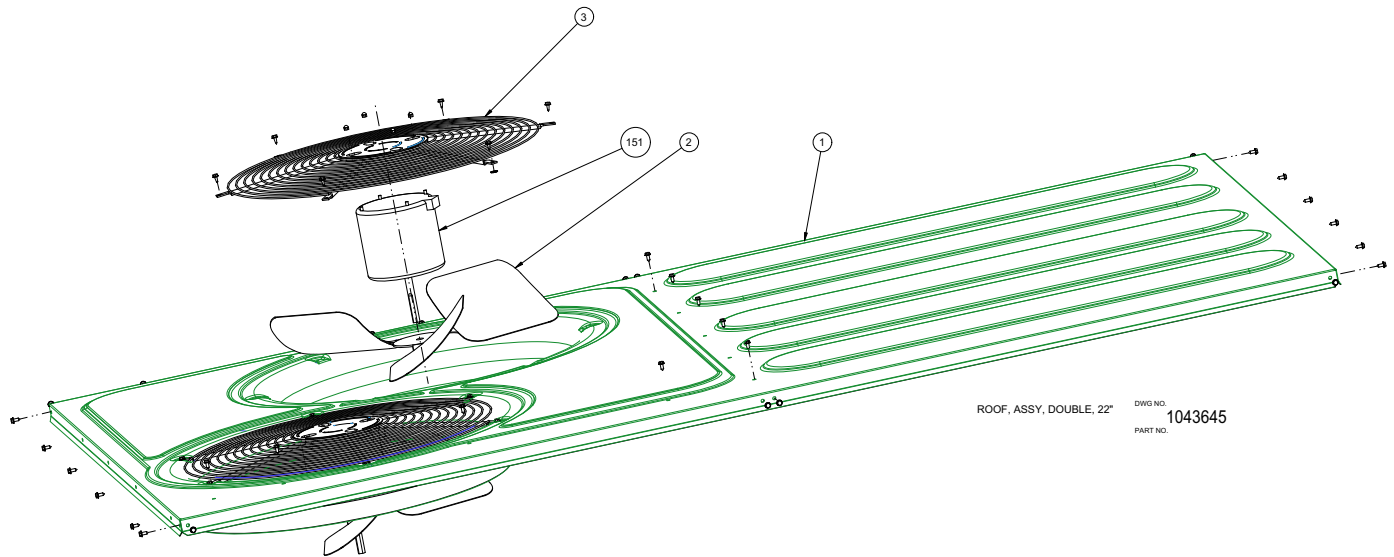

FIGURE 3

PIPING COMPONENTS ZY08 & ZY09

Item No.	See Figure	Description	Part Number	ZY08	ZY09
30	3	CNTRL,PRES,REFRIG,50/71(O/C) +/-5,SWEAT	S1-02435876000	2	2
31	3	CNTRL,PRES,REFRIG,650/450(O/C) PSIG	S1-02545253000	2	2
33	3	FILTER-DRIER,LIQUID 3/8 ODF,21 SQ IN	S1-52634088000	2	2
EVAPORATOR	3	COIL,EVAP,ZY08	S1-37335192000	1	
	3	COIL,EVAP,ZY08,ELECTROFIN	S1-37335192300	1*	
	3	COIL,EVAP,ZY09	S1-37335193000		1
	3	COIL,EVAP,ZY09,ELECTROFIN	S1-37335193300		1*
CONDENSER	3	COIL,COND,FORM,MC,25MM X 44,LFT	S1-32647163000	1	1
	3	COIL,COND,FORM,MC,25MM X 44,LFT, ELECTROFIN	S1-32647163300	1*	1*

*. OPTIONAL E-FIN COATING



ROOF, ASSY, DOUBLE, 22" DWG NO. 1043645
PART NO.

FIGURE 4

CONDENSER FAN MOTOR & AIR MOVING COMPONENTS ZY08, ZY09, ZX09 & ZX12

Item No.	See Figure	Description	Part Number
1	4	ROOF, COND,INSUL ASSY, DBL FAN, 22	S1-37335196000
2	4	FAN,PROP,22,CW,3-30,1/2 INCH BORE	S1-02642464000
3	4	GUARD,FAN,25.04 INCH B.C.,ROUND,BLACK	S1-02647157000
151	4	MTR,COND,1/4,1100/1,CW,VSD,208/230-1-60	S1-02436130000
151	4	MTR,COND,1/4,1100/1,CW,VSD,460-1-60	S1-02436131000
151	4	MTR,COND,1/4,1100/1,CW,VSD,575-1-60	S1-02436132000
151	4	MTR,COND,1/2,1085/1,CW,VSD,208/230-1-60	S1-02436133000
151	4	MTR,COND,1/2,1085/1,CW,VSD,460-1-60	S1-02436134000
151	4	MTR,COND,1/2,1085/1,CW,VSD,575-1-60	S1-02436135000
151	4	MTR,COND,1.5/1.25,1140/940,208/230/190-3	S1-02432068006
151	4	MTR,COND,1.5/1.25,1140/940,460/380/415-3	S1-02432068007
151	4	MTR,COND,1.5,1140,575-3-60	S1-02432068008

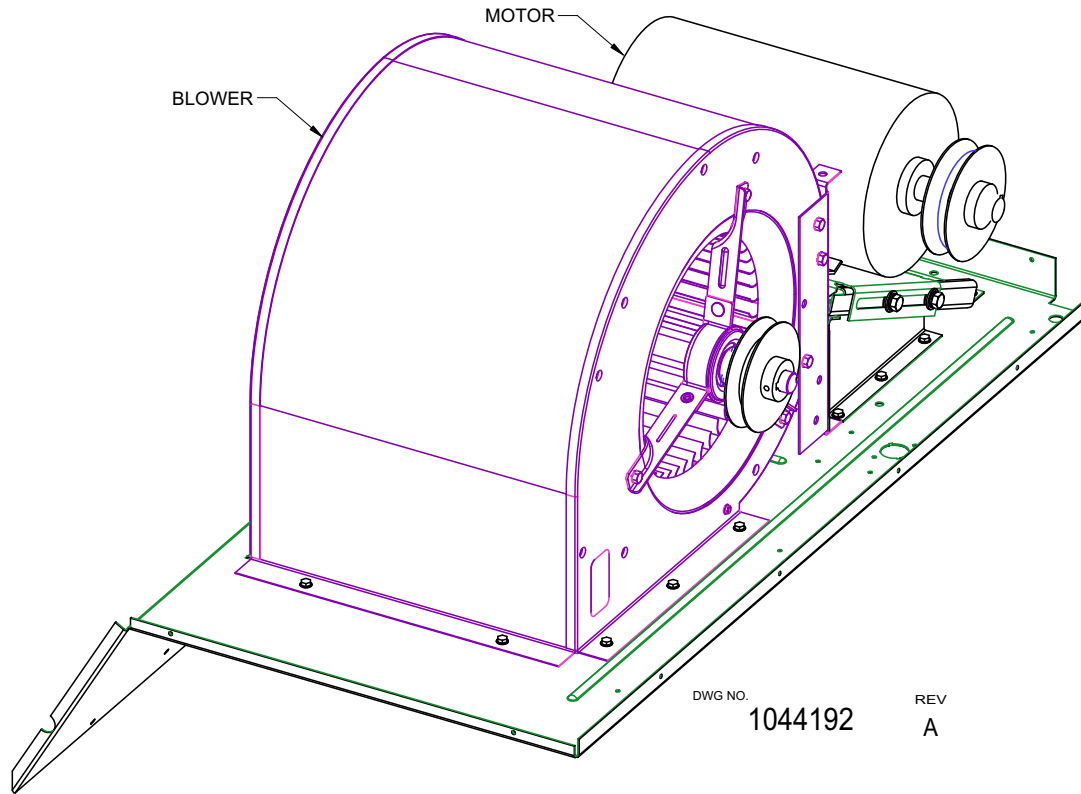

FIGURE 5

INDOOR BLOWER MOTOR & AIR MOVING COMPONENTS

Item	See Figure	Description	Part Number
BLOWER	5	BLW ASSEM W/HSG,WHEEL,15X15,SHAFT,BRNGS	S1-02647169000
*	*	PULLEY V-BELT 4L OD=80.01MM GROOVE=1	Special Order
*	*	SHEAVE,VAR,1GRV, .875BORE R:D	S1-02804764700
*	*	SHEAVE,VARIABLE 1 GRV,0.625" BORE,1VL44	S1-02806564700
*	*	SHEAVE,VARIABLE 1 GRV,0.875" BORE,1VM50	S1-02804807700
*	*	SHEAVE,VARIABLE 1 GRV,0.875" BORE,1VP56	S1-02804763700
*	*	SHEAVE,FIXED,1 GRV,3/4 INCH BORE,AK41	S1-02816444000
*	*	SHEAVE,FIXED 1 GRV,1" BORE,AK79	S1-02812496000
*	*	SHEAVE,FIXED,1 GRV,1 INCH BORE,BK85	S1-02816446000
*	*	SHEAVE,FIXED 1 GRV,1" BORE,AK74X1	S1-02813379000
*	*	Pulley V-Belt AK OD=113.03mm Groove=1	Special Order
*	*	SHEAVE,FIXED,1 GRV,3/4 INCH BORE,AK51	S1-02816445000
*	*	BELT,DRIVE,A37, PL=38.3	S1-02812422700
*	*	BELT,DRIVE A39,PL=40.3	S1-02815476000
*	*	BELT,V A50,PL=51.3	S1-02816441000
*	*	BELT,DRIVE BX52,PL=53.8	S1-02815475000
*	*	BELT,DRIVE,A47, PL=48.3	S1-02812366700
*	*	BELT,V A48,PL=49.3	S1-02816440000
*	*	BELT,V A40,PL=41.3	S1-02816439000
*	*	BELT,V A41,PL=42.3	S1-02815892000
*	*	BELT,DRIVE,A52, PL=53.3	S1-02812423700
*	*	BELT,DRIVE,BX54, PL=55.8	S1-02812063700

*. NOT SHOWN

BOX, ELECTRIC

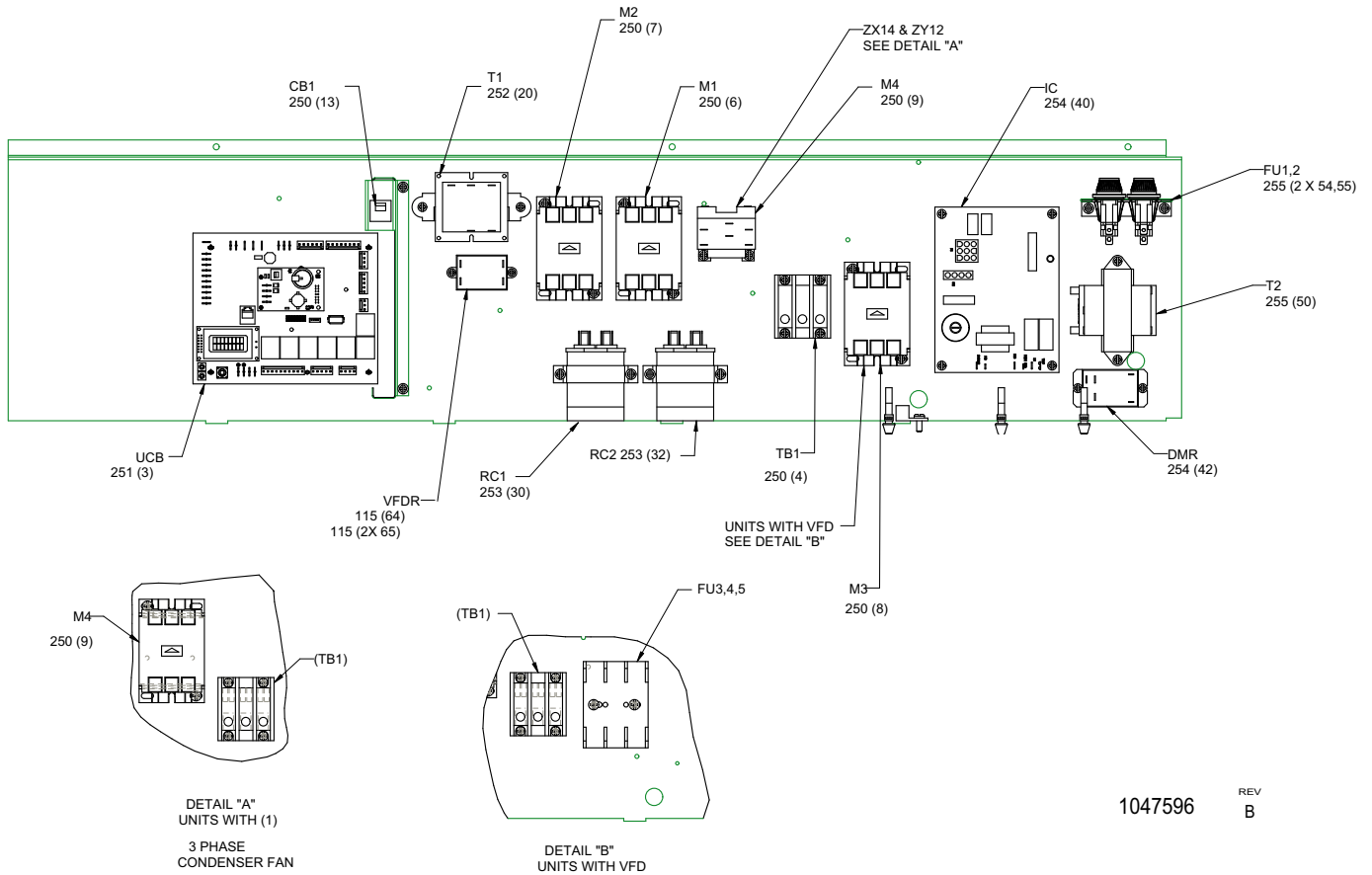

1047596 REV B

FIGURE 6

ELECTRIC COOLING & GAS HEAT

Item No.	See Figure	Description	ID	Part Number	BOX ELECTRIC	
					LFB 2 COMPR 2 FAN	LFB 2 COMPR 2 FAN VFD
4	6	BLOCK, TERMINAL	TB1	S1-02526380000	1	1
6	6	CONTACTOR, ELEC, 30 AMP R:A	M1	S1-02435803000	1	1
7	6	CONTACTOR, ELEC, 30 AMP R:A	M2	S1-02435803000	1	1
8	6	CONTACTOR, ELEC, 30 AMP R:A	M3	S1-02435803000	1	
9	6	RELAY, CNTRL, 24V, 60HZ, DPST (NO)	M4	S1-02436139000	1	1
13	6	CIRCUIT BREAKER, 3.2A 250V R:A	CB1	S1-02434532000	1	1
17	**	RAT SENSOR KIT		Special Order	1	1
18	**	SAT SENSOR KIT		Special Order	1	1
19	**	SENSOR, TEMPERATURE, 6 INCH LEAD, W/ TERM		S1-03103027000	1	1

** NOT SHOWN

3	6	BOARD, CNTRL, SES, 1 STAGE, W/O COMM, UCB1	UCB1	S1-03103022000		
	6	BOARD, CNTRL, SES, 2 STAGE, W/O COMM, UCB2	UCB2	S1-03103023000		
	6	BOARD, CNTRL, SES, 1 STAGE, WITH COMM, UCB1	UCB1	S1-03103024000		
	6	BOARD, CNTRL, SES, 2 STAGE, WITH COMM, UCB2	UCB2	S1-03103025000		

20	6	TRNSF, 208/230V, 24V/75VA, 50/60HZ	T1	S1-02525973700		
	6	TRNSF, 460V, 24V/75VA, 50/60HZ	T1	S1-02525974700		
	6	TRNSF, 575, 24, 75VA, 50/60HZ	T1	S1-02527729700		

ELECTRIC COOLING & GAS HEAT

Item No.	See Figure	Description	ID	Part Number	BOX ELECTRIC	
					LFB 2 COMPR 2 FAN	LFB 2 COMPR 2 FAN VFD
30	6	CAP,RUN DUAL,45/5MFD,370V,ROUND	RC1	S1-02425895700		
	6	CAP,RUN DUAL,70/5MFD,370V,ROUND	RC1	S1-02427616000		
	6	CAP,RUN DUAL,80/10MFD,370V,ROUND	RC1	S1-02427522000		
	6	CAP,RUN,DUAL,70/10MFD,370V,ROUND	RC1	S1-02436140000		
	6	CAP,RUN SINGLE,5MFD,370V,OVAL	RC1	S1-02420043700		
	6	CAP,RUN SINGLE,10MFD,370V,FLAT	RC1	S1-02420046700		
	6	CAP,RUN SINGLE,7.5MFD,370V,FLAT	RC1	S1-02420045700		
32	6	CAP,RUN SINGLE,10MFD,370V,FLAT	RC2	S1-02420046700		
	6	CAP,RUN SINGLE,7.5MFD,370V,FLAT	RC2	S1-02420045700		

GAS HEAT COMPONENTS

40	6	BOARD,CNTRL,SPARK,2 STAGE	IC	S1-03103021000	1	
42	6	RELAY,CNTRL,24VAC,60HZ,DPST (NO)	DMR	S1-02436138000	1	
50	6	TRNSF,460/575/230V,60HZ	T2	S1-02541291000		
54	6	FUSE HOLDER,1 POLE,30 AMP,600V		S1-02544135000	2	
55	6	FUSE,DUAL,TIME DELAY,600V,0.50AMP	FU1,2	S1-02532771001		

SPECIAL ORDER AS OF DATE DOCUMENT PRINT

**NOT SHOWN

STANDARD FILTER

Item No.	See Figure	Description	QTY	Part Number	Voltage		
					208/230	460	575
**	**	FILTER,AIR TROWA 2 R:B	4	S1-02602043000	4	4	4